

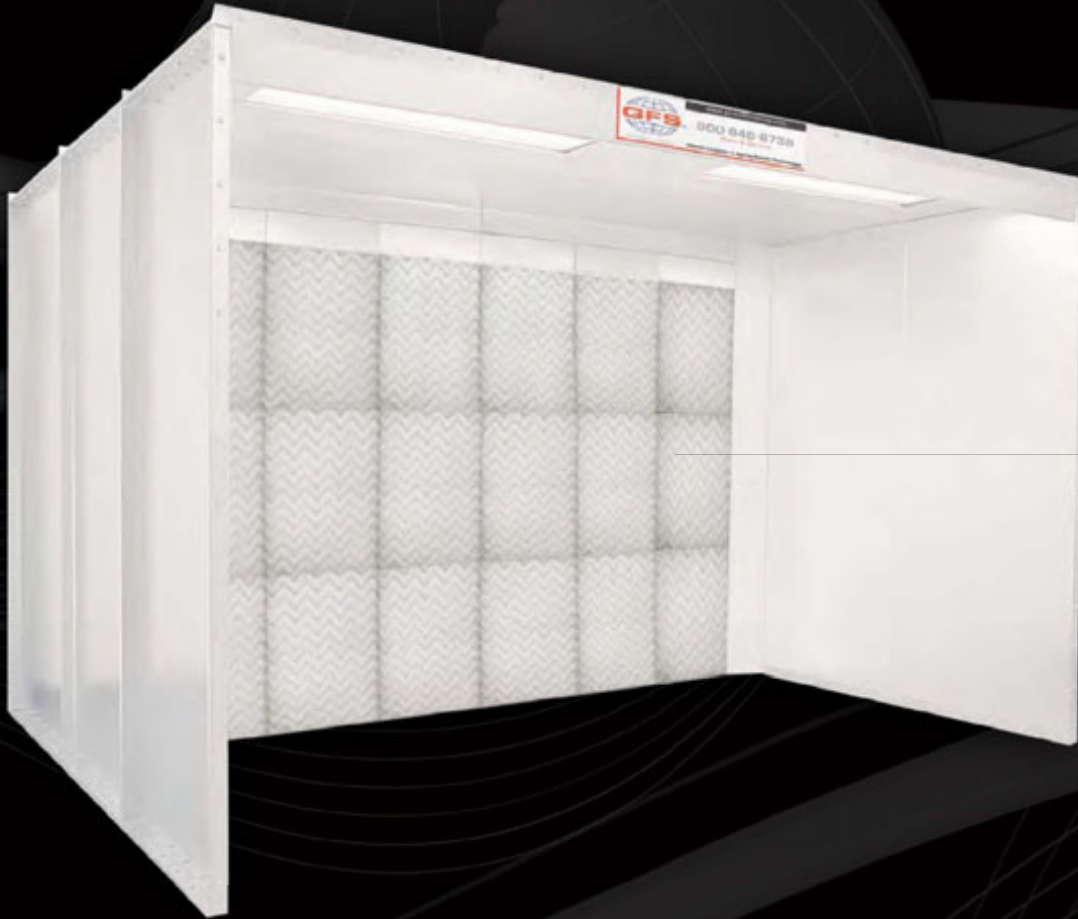

GLOBAL FINISHING SOLUTIONS

Open-Face Booths

FAST-PACK & INDUSTRIAL MODELS



- Expandable Modular Design
- Easy Assembly
- Heavy Duty Construction
- Meet or Exceeds National Code Requirements
- Custom Booths Available
 - Conveyor and Crane Openings



Our most popular and affordable product line, GFS Fast-Pack (Open Face) Paint Booths provide a safe, clean environment for your finishing operations. With a unique, modular design, GFS can design and build an open face booth in virtually any size or configuration to meet your specific requirements.

BOOTH FEATURES

Exhaust Chamber

Air is filtered through an exhaust chamber as it exits the booth. Exhaust stacks are required to ventilate the booth to the outside.

Solid Construction

Pre-punched booth panels and nut-and-bolt assembly takes the guesswork out of installing a paint booth, and provides more structural integrity.

Heavy-Duty Panels

GFS Open Face Booths are constructed with single-skin, 18-gauge, G-90 galvanized steel.

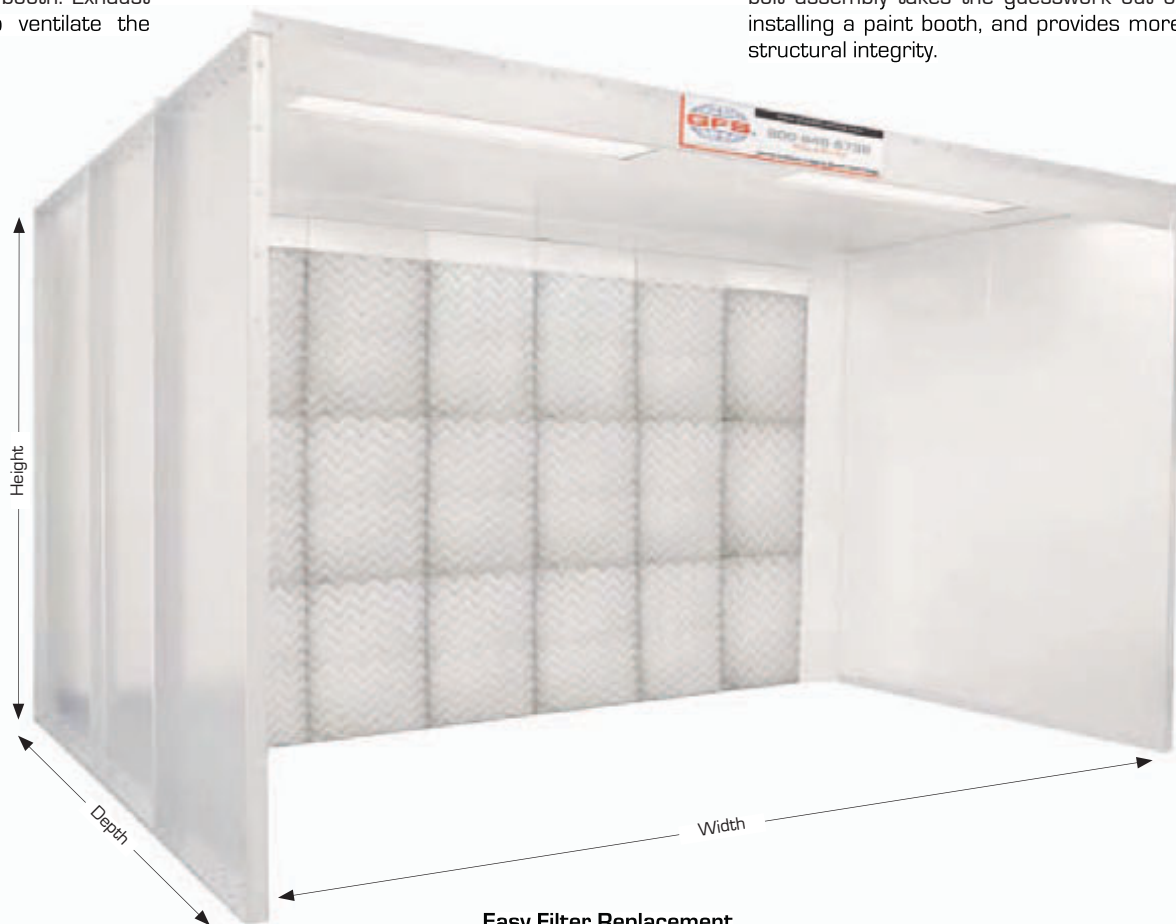

Selecting a Booth Size

Deciding on the right size paint booth isn't always an easy task. Use the following guidelines to help you determine the appropriate size booth for your needs.

- **Width:** Width of the largest item (including fixture or pallet) plus 5 feet
- **Height:** Height of the largest item (including fixture or pallet) plus 2 feet
- **Depth:** Depth of the largest item plus 3 feet (clearance at the rear)

Easy Filter Replacement



- Installing and replacing filters is easy with the grid system.
- Each booth comes complete with a full set of GFS Wave 20" x 20" exhaust filters. Avoid wasting filters by replacing only the filter squares that need changing.
- An included manometer indicates when filters need to be replaced.

Additional Sizing Considerations

- **Conveyorized Booths:** Width must be sufficient to allow finishers to complete the finishing operation within the allotted time. Spraying should not be closer than 2 feet from the conveyor opening.
- **Bridge Intake Chambers w/ Solid Doors:** Booth opening is decreased by 2 feet high and 4 feet wide on a booth with a bridge intake chamber
- **Filtered Doors for Large Booths (12 Ft. wide or larger):** Booth opening is decreased by 4 feet wide when using filtered doors on large booths.

Fans & Motors

High-powered fans and motors are required to create adequate airflow within a paint booth. Each GFS booth includes a non-sparking, tube axial exhaust fan(s) with belt guards and duct connector ring, and a 3-phase, TEFC, tri-voltage motor(s) with variable pitch pulley.



Superior Lighting

The majority of GFS' open face booths feature integrated 4-tube, inside-access fluorescent light fixtures. GFS light fixtures are ETL listed (Class 1 Division 2) and come complete with T-8 color-corrected tubes.



Code Requirements:

Paint finishing equipment manufactured by GFS is designed to meet the applicable requirements of various codes and industry recognized standards. For spray applications using flammable and combustible materials, the standards are NFPA 33 and Chapter 24 of the International Fire Code (IFC). For curing and drying applications, the standards are NFPA 86 and Chapter 30 of the IFC. Often local requirements vary from these national codes and standards so it is important that you consult the local authority having jurisdiction before specifying and purchasing paint finishing equipment.



BOOTH OPTIONS

- Pre-painted white panels (May require additional lead times; consult GFS).
- Single-phase, explosion-proof and/or 575 V/50 Hz exhaust fan motor
- 4-foot, 6-tube fluorescent light fixtures with color-corrected tubes
- Rear-access, ETL-listed light fixtures
- UL listed:
 - Booth packages
 - Prewired control panels
 - Individual control panel components
- Exhaust ductwork

PRODUCT AVAILABILITY

Fast-Pack EXPRESS Booths

- Prepackaged and ready to ship in 3 business days
- All EXPRESS models include interchangeable top or rear exhaust panels.

Small & Large Fast-Pack Booths

- Ship within 7 business days
- All standard models have an interchangeable top or rear exhaust panel with the exception of the 18 ft. wide by 12 ft. high and 20 ft. wide by 12 ft. high models.

Modifications, options and air replacement systems may require additional lead times and DO NOT qualify for 3- or 7-day shipment.

Consult GFS for modifications affecting pricing and production lead times.

Notes:

- GFS recommends proper air replacement system. Contact GFS if air replacement is needed.
- GFS industrial booths are intended for indoor installation only.
- Air solenoid valve required for all installations for light lens switch and fan, priced separately.
- **All specifications are subject to change without prior notice. (Booth model numbers may vary based on order entry process)**



FAST-PACK PAINT BOOTH MODELS

TOUCH-UP & BENCH TOP BOOTHS

Model No.		Working Dimensions			Overall Dimensions			CFM	FAN	HP	No.	No.
Standard	<i>Fast-Pack EXPRESS</i>	W	H	D	W	H	D	1/4" SP @ 100 FPM	Dia.		Filters	Lights
IFP-3-BT	<i>IFPX-3-BT</i>	3'	4'	2'	3'-4"	4'-4"	4'-2"	1200	12"	1/3	2	0
IFP-3	<i>IFPX-3</i>	3'	4'	2'	3'-4"	7'-2"	4'-2"	1200	12"	1/3	2	0
IFP-4	<i>IFPX-4</i>	4'	4'	3'	4'-4"	7'-2"	5'-2"	1600	18"	1/3	4	0
IFP-5	<i>IFPX-5</i>	5'	4'	3'	5'-4"	7'-2"	5'-2"	2000	18"	1/2	6	1
IFP-7	<i>IFPX-7</i>	7'	4'	3'	7'-4"	7'-2"	5'-2"	2800	18"	3/4	8	1

SMALL BOOTHS

Model No.		Working Dimensions			Overall Dimensions			CFM	FAN	HP	No.	No.
Standard	<i>Fast-Pack EXPRESS</i>	W	H	D	W	H	D	1/4" SP @ 100 FPM	Dia.		Filters	Lights

6 Ft. Wide Booths

IFP-060706	<i>IFPX-676</i>	6'	7'	6'	6'-4"	7'-2"	9'-2"	5250	24	1	12	1
IFP-060709	<i>IFPX-679</i>	6'	7'	9'	6'-4"	7'-2"	12'-2"	5250	24	1	12	1
IFP-060712		6'	7'	12'	6'-4"	7'-2"	15'-2"	5250	24	1	12	2
IFP-060806		6'	8'	6'	6'-4"	8'-2"	9'-2"	6000	24	2	12	1
IFP-060809		6'	8'	9'	6'-4"	8'-2"	12'-2"	6000	24	2	12	1
IFP-060812		6'	8'	12'	6'-4"	8'-2"	15'-2"	6000	24	2	12	2
IFP-061006		6'	10'	6'	6'-4"	10'-2"	9'-2"	7500	24	2	15	1
IFP-061009		6'	10'	9'	6'-4"	10'-2"	12'-2"	7500	24	2	15	1
IFP-061012		6'	10'	12'	6'-4"	10'-2"	15'-2"	7500	24	2	15	2
IFP-061206		6'	12'	6'	6'-4"	12'-2"	9'-2"	9000	30	3	21	1
IFP-061209		6'	12'	9'	6'-4"	12'-2"	12'-2"	9000	30	3	21	1
IFP-061212		6'	12'	12'	6'-4"	12'-2"	15'-2"	9000	30	3	21	2

8 Ft. Wide Booths

IFP-080706	<i>IFPX-876</i>	8'	7'	6'	8'-4"	7'-2"	9'-2"	7000	24	2	16	1
IFP-080709	<i>IFPX-879</i>	8'	7'	9'	8'-4"	7'-2"	12'-2"	7000	24	2	16	1
IFP-080712		8'	7'	12'	8'-4"	7'-2"	15'-2"	7000	24	2	16	2
IFP-080806	<i>IFPX-886</i>	8'	8'	6'	8'-4"	8'-2"	9'-2"	8000	30	2	16	1
IFP-080809	<i>IFPX-889</i>	8'	8'	9'	8'-4"	8'-2"	12'-2"	8000	30	2	16	1
IFP-080812		8'	8'	12'	8'-4"	8'-2"	15'-2"	8000	30	2	16	2
IFP-081006		8'	10'	6'	8'-4"	10'-2"	9'-2"	10000	30	3	20	1
IFP-081009		8'	10'	9'	8'-4"	10'-2"	12'-2"	10000	30	3	20	1
IFP-081012		8'	10'	12'	8'-4"	10'-2"	15'-2"	10000	30	3	20	2
IFP-081206		8'	12'	6'	8'-4"	12'-2"	9'-2"	12000	30	5	28	1
IFP-081209		8'	12'	9'	8'-4"	12'-2"	12'-2"	12000	30	5	28	1
IFP-081212		8'	12'	12'	8'-4"	12'-2"	15'-2"	12000	30	5	28	2

SMALL BOOTHS

Model No.	Working Dimensions	Overall Dimensions	CFM	FAN	HP	No. Filters	No. Lights
Standard <i>Fast-Pack EXPRESS</i>	W x H x D	W x H x D	1/4" SP @ 100 FPM	Dia.			

10 Ft. Wide Booths

IFP-100706 <i>IFPX-1076</i>	10' 7' 6'	10'-4" 7'-2" 9'-2"	8750	30	3	20	2
IFP-100709 <i>IFPX-1079</i>	10' 7' 9'	10'-4" 7'-2" 12'-2"	8750	30	3	20	2
IFP-100712	10' 7' 12'	10'-4" 7'-2" 15'-2"	8750	30	3	20	4
IFP-100806 <i>IFPX-1086</i>	10' 8' 6'	10'-4" 8'-2" 9'-2"	10000	30	3	20	2
IFP-100809 <i>IFPX-1089</i>	10' 8' 9'	10'-4" 8'-2" 12'-2"	10000	30	3	20	2
IFP-100812	10' 8' 12'	10'-4" 8'-2" 15'-2"	10000	30	3	20	4
IFP-101006	10' 10' 6'	10'-4" 10'-2" 9'-2"	12500	30	5	25	2
IFP-101009	10' 10' 9'	10'-4" 10'-2" 12'-2"	12500	30	5	25	2
IFP-101012	10' 10' 12'	10'-4" 10'-2" 15'-2"	12500	30	5	25	4
IFP-101206	10' 12' 6'	10'-4" 12'-2" 9'-2"	15000	34	5	35	2
IFP-101209	10' 12' 9'	10'-4" 12'-2" 12'-2"	15000	34	5	35	2
IFP-101212	10' 12' 12'	10'-4" 12'-2" 15'-2"	15000	34	5	35	4

ADDING WORK DEPTH

Standard Small Booths - 6, 8, & 10 Ft. wide

Working compartment extensions are specifically designed to increase the working depth of the spray booth. Increasing the work depth will be using 2 ft. or 3 ft. solid and/or lighted extensions (Notice ceiling panels run side to side).

- 18 Gauge G-90 galvanized panel construction
- Assembly hardware included

Options:

- Pre-coated white panels (Structural components, exhaust and filter parts are galvanized)
- Appropriate structural reinforcements

Booth with standard 6 ft. working depth and exhaust chamber

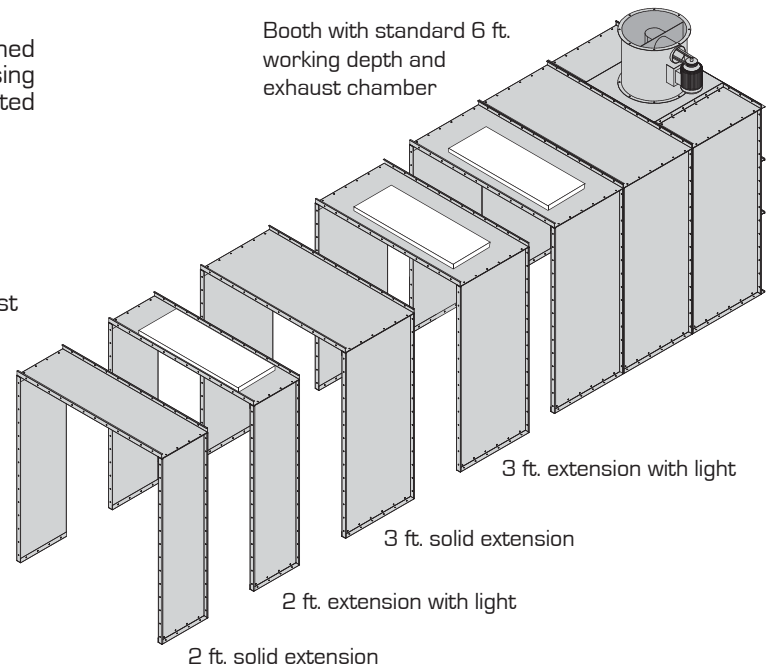

LARGE BOOTHS

Model No.	Working Dimensions W x H x D			Overall Dimensions W x H x D			CFM 1/4" SP @ 125 FPM	FAN Dia.	HP	No. Filters	No. Lights
-----------	---------------------------------	--	--	---------------------------------	--	--	-----------------------------	-------------	----	----------------	---------------

12 Ft. Wide Booths

IFP-120706	12'	7'	6'	12'-4"	7'-10"	10'-2"	10500	34	2	28	2 or 4
IFP-120709	12'	7'	9'	12'-4"	7'-10"	13'-2"	10500	34	2	28	2 or 4
IFP-120712	12'	7'	12'	12'-4"	7'-10"	16'-2"	10500	34	2	28	4 or 8
IFP-120806	12'	8'	6'	12'-4"	8'-10"	10'-2"	12000	34	3	28	2 or 4
IFP-120809	12'	8'	9'	12'-4"	8'-10"	13'-2"	12000	34	3	28	2 or 4
IFP-120812	12'	8'	12'	12'-4"	8'-10"	16'-2"	12000	34	3	28	4 or 8
IFP-121006	12'	10'	6'	12'-4"	10'-10"	10'-2"	15000	34	5	35	2 or 4
IFP-121009	12'	10'	9'	12'-4"	10'-10"	13'-2"	15000	34	5	35	2 or 4
IFP-121012	12'	10'	12'	12'-4"	10'-10"	16'-2"	15000	34	5	35	4 or 8
IFP-121206	12'	12'	6'	12'-4"	12'-10"	10'-2"	18000	40	5	49	2 or 4
IFP-121209	12'	12'	9'	12'-4"	12'-10"	13'-2"	18000	40	5	49	2 or 4
IFP-121212	12'	12'	12'	12'-4"	12'-10"	16'-2"	18000	40	5	49	4 or 8

14 Ft. Wide Booths

IFP-140706	14'	7'	6'	14'-4"	7'-10"	10'-2"	12250	34	2	32	2 or 4
IFP-140709	14'	7'	9'	14'-4"	7'-10"	13'-2"	12250	34	2	32	2 or 4
IFP-140712	14'	7'	12'	14'-4"	7'-10"	16'-2"	12250	34	2	32	4 or 8
IFP-140806	14'	8'	6'	14'-4"	8'-10"	10'-2"	14000	34	3	32	2 or 4
IFP-140809	14'	8'	9'	14'-4"	8'-10"	13'-2"	14000	34	3	32	2 or 4
IFP-140812	14'	8'	12'	14'-4"	8'-10"	16'-2"	14000	34	3	32	4 or 8
IFP-141006	14'	10'	6'	14'-4"	10'-10"	10'-2"	17500	40	5	40	2 or 4
IFP-141009	14'	10'	9'	14'-4"	10'-10"	13'-2"	17500	40	5	40	2 or 4
IFP-141012	14'	10'	12'	14'-4"	10'-10"	16'-2"	17500	40	5	40	4 or 8
IFP-141206	14'	12'	6'	14'-4"	12'-10"	10'-2"	21000	40	5	56	2 or 4
IFP-141209	14'	12'	9'	14'-4"	12'-10"	13'-2"	21000	40	5	56	2 or 4
IFP-141212	14'	12'	12'	14'-4"	12'-10"	16'-2"	21000	40	5	56	4 or 8

16 Ft. Wide Booths

IFP-160706	16'	7'	6'	16'-4"	7'-10"	10'-2"	14000	34	3	36	2 or 4
IFP-160709	16'	7'	9'	16'-4"	7'-10"	13'-2"	14000	34	3	36	2 or 4
IFP-160712	16'	7'	12'	16'-4"	7'-10"	16'-2"	14000	34	3	36	4 or 8
IFP-160806	16'	8'	6'	16'-4"	8'-10"	10'-2"	16000	34	5	36	2 or 4
IFP-160809	16'	8'	9'	16'-4"	8'-10"	13'-2"	16000	34	5	36	2 or 4
IFP-160812	16'	8'	12'	16'-4"	8'-10"	16'-2"	16000	34	5	36	4 or 8
IFP-161006	16'	10'	6'	16'-4"	10'-10"	10'-2"	20000	40	5	45	2 or 4
IFP-161009	16'	10'	9'	16'-4"	10'-10"	13'-2"	20000	40	5	45	2 or 4
IFP-161012	16'	10'	12'	16'-4"	10'-10"	16'-2"	20000	40	5	45	4 or 8
IFP-161206	16'	12'	6'	16'-4"	12'-10"	10'-2"	24000	40	7.5	63	2 or 4
IFP-161209	16'	12'	9'	16'-4"	12'-10"	13'-2"	24000	40	7.5	63	2 or 4
IFP-161212	16'	12'	12'	16'-4"	12'-10"	16'-2"	24000	40	7.5	63	4 or 8

LARGE BOOTHS

Model No.	Working Dimensions W x H x D			Overall Dimensions W x H x D			CFM 1/4" SP @ 125 FPM	FAN Dia.	HP	No. Filters	No. Lights
-----------	---------------------------------	--	--	---------------------------------	--	--	-----------------------------	-------------	----	----------------	---------------

18 Ft. Wide Booths

IFP-180706	18'	7'	6'	18'-4"	7'-10"	10'-2"	15750	34	5	40	3 or 5
IFP-180709	18'	7'	9'	18'-4"	7'-10"	13'-2"	15750	34	5	40	3 or 5
IFP-180712	18'	7'	12'	18'-4"	7'-10"	16'-2"	15750	34	5	40	6 or 10
IFP-180806	18'	8'	6'	18'-4"	8'-10"	10'-2"	18000	40	5	40	3 or 5
IFP-180809	18'	8'	9'	18'-4"	8'-10"	13'-2"	18000	40	5	40	3 or 5
IFP-180812	18'	8'	12'	18'-4"	8'-10"	16'-2"	18000	40	5	40	6 or 10
IFP-181006	18'	10'	6'	18'-4"	10'-10"	10'-2"	22500	40	5	50	3 or 5
IFP-181009	18'	10'	9'	18'-4"	10'-10"	13'-2"	22500	40	5	50	3 or 5
IFP-181012	18'	10'	12'	18'-4"	10'-10"	16'-2"	22500	40	5	50	6 or 10
IFP-181206	18'	12'	6'	18'-4"	12'-10"	10'-2"	27000	48	5	70	3 or 5
IFP-181209	18'	12'	9'	18'-4"	12'-10"	13'-2"	27000	48	5	70	3 or 5
IFP-181212	18'	12'	12'	18'-4"	12'-10"	16'-2"	27000	48	5	70	6 or 10

20 Ft. Wide Booths

IFP-200706	20'	7'	6'	20'-4"	7'-10"	10'-2"	17500	40	5	44	4 or 6
IFP-200709	20'	7'	9'	20'-4"	7'-10"	13'-2"	17500	40	5	44	4 or 6
IFP-200712	20'	7'	12'	20'-4"	7'-10"	16'-2"	17500	40	5	44	8 or 12
IFP-200806	20'	8'	6'	20'-4"	8'-10"	10'-2"	20000	40	5	44	4 or 6
IFP-200809	20'	8'	9'	20'-4"	8'-10"	13'-2"	20000	40	5	44	4 or 6
IFP-200812	20'	8'	12'	20'-4"	8'-10"	16'-2"	20000	40	5	44	8 or 12
IFP-201006	20'	10'	6'	20'-4"	10'-10"	10'-2"	25000	40	7.5	55	4 or 6
IFP-201009	20'	10'	9'	20'-4"	10'-10"	13'-2"	25000	40	7.5	55	4 or 6
IFP-201012	20'	10'	12'	20'-4"	10'-10"	16'-2"	25000	40	7.5	55	8 or 12
IFP-201206	20'	12'	6'	20'-4"	12'-10"	10'-2"	30000	48	7.5	77	4 or 6
IFP-201209	20'	12'	9'	20'-4"	12'-10"	13'-2"	30000	48	7.5	77	4 or 6
IFP-201212	20'	12'	12'	20'-4"	12'-10"	16'-2"	30000	48	7.5	77	8 or 12

ADDING WORK DEPTH

Standard Large Booths - 12, 14, 16, 18 & 20 Ft. wide

Working compartment extensions are specifically designed to increase the working depth of the spray booth. Increasing the work depth for large booths will be to use one or a combination of 5 ft., 6 ft., 7 ft., 8 ft., 9 ft. or 10 ft. extensions (Notice ceiling panels run back to front).

- 18 Gauge G-90 galvanized panel construction
- Appropriate structural reinforcements and assembly hardware included

Option:

- Pre-coated white panels (Structural components, exhaust and filter parts are galvanized)
- Standard large booth extensions have multiple light upgrade options:
 - 12 ft. -16 ft. wide = 2 or 4 lights
 - 18 ft. wide = 3 or 5 lights OR 6 or 10 lights
 - 20 ft. wide = 4 or 6 lights OR 8 or 12 lights

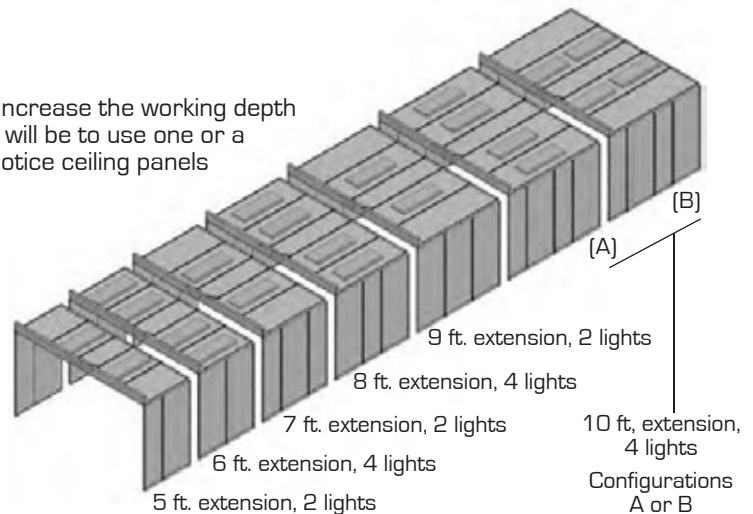

For Small Booths:
6, 8, & 10 Ft. wide

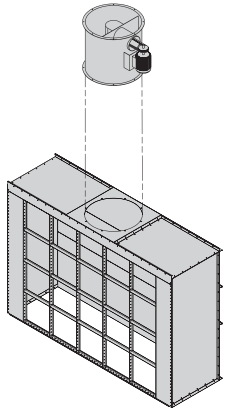

Model No.	CFM 1/4" SP @ 125FPM	Fan Dia.	HP	No. of Filters
6 Ft. Wide Booths				
PEC-0607	5250	24	1	12
PEC-0608	6000	24	2	12
PEC-0610	7500	24	2	15
PEC-0612	9000	30	3	21
8 Ft. Wide Booths				
PEC-0807	7000	24	2	16
PEC-0808	8000	30	2	16
PEC-0810	10000	30	3	20
PEC-0812	12000	30	5	28
10 Ft. Wide Booths				
PEC-1007	8750	30	3	20
PEC-1008	10000	30	3	20
PEC-1010	12500	30	5	25
PEC-1012	15000	34	5	35

For Large Booths:
12, 14, 16, 18, & 20 Ft. wide

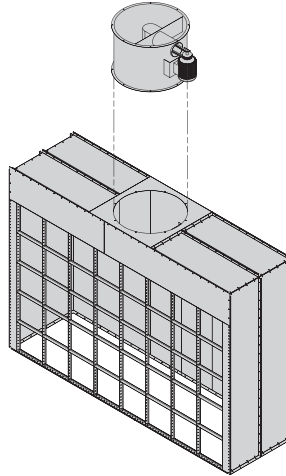

Model No.	CFM 1/4" SP @ 125FPM	Fan Dia.	HP	No of Filters
12 Ft. Wide Booths				
PEC-1207	10500	34	2	28
PEC-1208	12000	34	3	28
PEC-1210	15000	34	5	35
PEC-1212	18000	40	5	49
14 Ft. Wide Booths				
PEC-1407	12250	34	2	32
PEC-1408	14000	34	3	32
PEC-1410	17500	40	5	40
PEC-1412	21000	40	5	56
16 Ft. Wide Booths				
PEC-1607	14000	34	3	36
PEC-1608	16000	34	5	36
PEC-1610	20000	40	5	45
PEC-1612	24000	40	7.5	63
18 Ft. Wide Booths				
PEC-1807	15750	34	5	40
PEC-1808	18000	40	5	40
PEC-1810	22500	40	5	50
PEC-1812	27000	48	5	70
20 Ft. Wide Booths				
PEC-2007	17500	40	5	44
PEC-2008	20000	40	5	44
PEC-2010	25000	40	7.5	55
PEC-2012	30000	48	7.5	77

Fan Note: NFPA 33 requires that the motor and belt be placed outside of spray area. GFS recommends placement of fan assembly on roof of building if spraying flammable liquids.

INTAKE CHAMBERS

Used to enclose or supply air directly to open face booths for maximum in cleanliness or when heated air replacement is used.

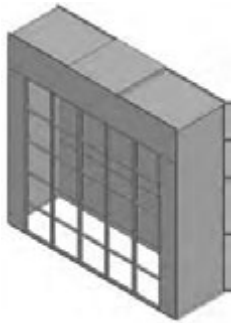

Solid-Back Intake Chambers are used to supply replacement air to booths with conveyor openings or booths that use side access doors for product and/or personnel entry and exit.

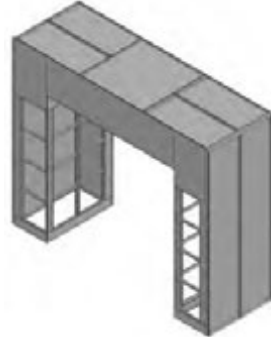

Bridge Intake Chambers are used to supply air to booths with end product entry and exit doors. They may be used with solid entry doors to completely enclose the working area of the booth. When adding a bridge style chamber, door size will be 2 feet shorter than interior booth height and 4 feet narrower than interior booth width. An air replacement unit or intake fan can be included.

Note: Intake chambers require additional delivery time than the 7 business days for a standard Fast-Pack booth.

PERSONNEL DOORS

- Universal access door - allows personnel or product access to the booth. Standard size 3 ft. wide by 7 ft. high opening.
- Door can be installed for either right or left hand swing.
- Observation windows (18" x 24"), sealed windows allow viewing of operations. Clear tempered glass.
- Constructed of 18 Gauge galvanized sheet steel.

Options:

- Solid Door (No Window)
- Double Personnel Door

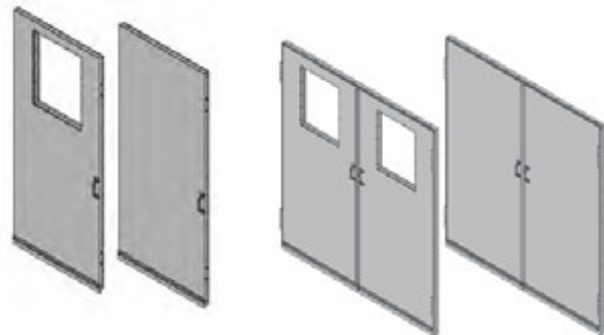

All enclosed booths require at least one exit with a maximum door width of 4 ft.

Filtered Doors

Filtered entry doors allow product entry and exit while filtering the input air. These doors attach directly to the front of the booth, adds minimal depth to the booth, and are used with non-pressurized booths.

For Small Booths:
 6, 8, & 10 Ft. wide

For Large Booths:
 12, 14, 16, 18, & 20 Ft. wide

Door size will be 4 ft. narrower than booth.

Note: Product doors require additional delivery time than the 7 business days for a standard Fast-Pack booth.



Solid Doors

Solid entry doors are used with pressurized input plenums to enclose open face paint booths in pressurized applications. Door size will be 2 feet shorter than interior booth height and 4 feet narrower than interior booth width.

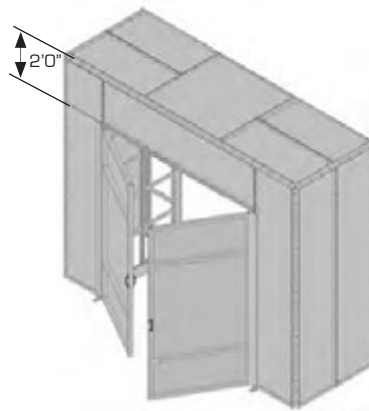

Options:

- Tri-Fold Doors
- Bi-Fold Doors

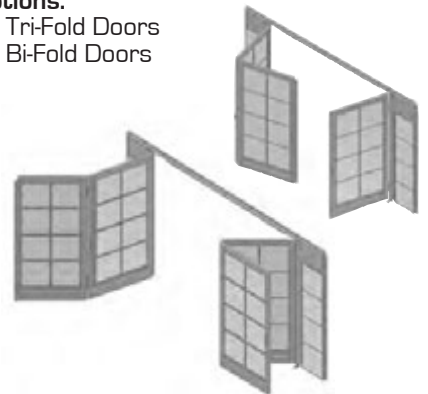

(Drawings are for illustration purposes only)

AIR REPLACEMENT UNITS

During paint spray operations, the paint booth's exhaust system removes significant quantities of plant air. A typical eight by ten foot booth exhausts more than 8,000 cubic feet of air per minute. If replaced air is pulled directly from outside, this volume may be sufficient to cool the interior of the building and may adversely affect the quality of the coating.

GFS direct gas fired air replacement units are an economical source of replacement air. Air replacement units supply tempered and filtered air to the booth, minimizing temperature variations and removing particulates that compromise finish quality.

In pressurized booths, replacement air is dispersed directly into the paint booth plenum. When elevated temperatures are required, forced dry systems are available.

Mounting Options:

- Indoor/Outdoor vertical
- Indoor/Outdoor horizontal
- Platforms
- Ceiling suspended

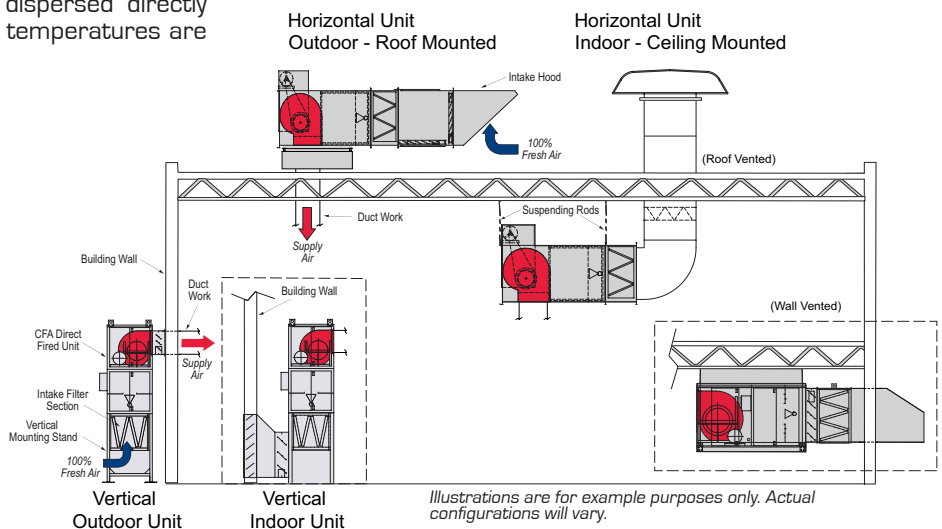

Illustrations are for example purposes only. Actual configurations will vary.

Conveyor openings are available on floor models as a custom option. GFS is the leader in custom designed booths. Engineers are on staff capable of designing booths for any application. Please refer to chart for recommended maximum openings.

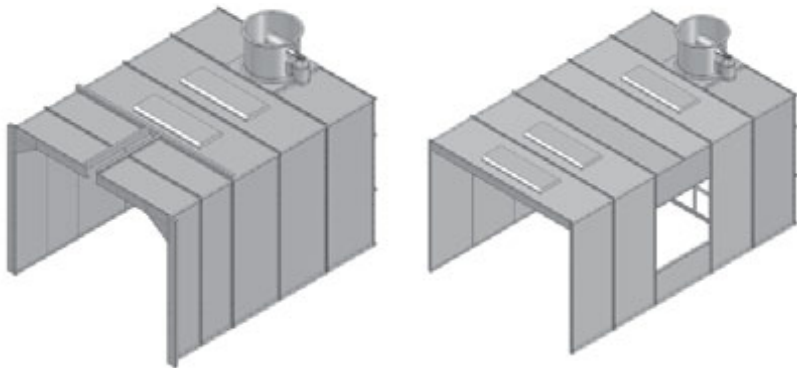

Illustration shows an example of a Crane Slot for Small Booths (6 ft. to 10 ft. wide), Consult GFS for openings for Large Booths (12 ft. wide or wider).

CUSTOM BOOTH INFORMATION

Providing the following information will help us assist you in developing a "Custom Booth".

- Size and Weight of largest product to be coated
- How do you move your product: Conveyor Rail Cart
- Provide pictures or sketches

Working Dimensions:

Height: _____ Width: _____ Depth: _____

Floor Space Available: Width: _____ Depth: _____

Ceiling Height: _____

Number of Lights: _____ Type: 4 tube 6 tube

Type of Intake Chamber: Solid Back Bridge

Product Doors: Filtered Solid Swing Tri-Fold Bi-Fold

Man Doors: Qty: _____

Observation Window: Height: _____ Width: _____

Opening Size: Crane Slot: _____ Conveyor Slot: _____

Model No.	Working Dimensions (W x H x D)			Maximum Opening (Sq. Ft.)
Small Booths				
6 Ft. Wide Booths				
IDB-060706	6'	7'	6'	10
IDB-060806	6'	8'	6'	12
IDB-061006	6'	10'	6'	15
IDB-061206	6'	12'	6'	18
8 Ft. Wide Booths				
IDB-080706	8'	7'	6'	14
IDB-080806	8'	8'	6'	16
IDB-081006	8'	10'	6'	20
IDB-081206	8'	12'	6'	24
10 Ft. Wide Booths				
IDB-100706	10'	7'	6'	16
IDB-100806	10'	8'	6'	19
IDB-101006	10'	10'	6'	23
IDB-101206	10'	12'	6'	29

Large Booths

12 Ft. Wide Booths				
IDB-120706	12'	7'	6'	21
IDB-120806	12'	8'	6'	24
IDB-121006	12'	10'	6'	30
IDB-121206	12'	12'	6'	36
14 Ft. Wide Booths				
IDB-140706	14'	7'	6'	24
IDB-140806	14'	8'	6'	28
IDB-141006	14'	10'	6'	35
IDB-141206	14'	12'	6'	42
16 Ft. Wide Booths				
IDB-160706	16'	7'	6'	28
IDB-160806	16'	8'	6'	32
IDB-161006	16'	10'	6'	40
IDB-161206	16'	12'	6'	48
18 Ft. Wide Booths				
IDB-180706	18'	7'	6'	31
IDB-180806	18'	8'	6'	36
IDB-181006	18'	10'	6'	45
IDB-181206	18'	12'	6'	54
20 Ft. Wide Booths				
IDB-200706	20'	7'	6'	35
IDB-200806	20'	8'	6'	40
IDB-201006	20'	10'	6'	50
IDB-201206	20'	12'	6'	60

CUSTOM EXPERTISE

An experienced engineering team provides pre-contract, mechanical, electrical, AutoCAD, PLC and programming functions on custom and standard equipment orders. Continuous improvement of standard products, development of heat transfer processes, implementation of state-of-the-art controls and materials specifications means that our customers will receive a safe, reliable, quality product.

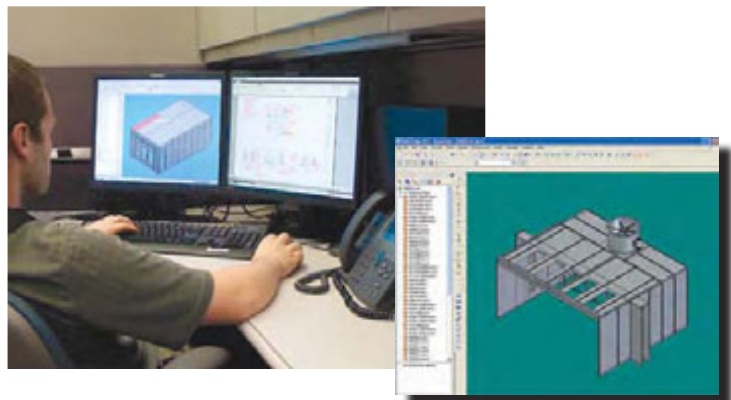

APPROVED REPLACEMENT PARTS & FILTERS



GFS offers a full line of replacement parts, filters and paint booth accessories. Great emphasis is placed on engineering and workmanship so that you receive the best products at competitive prices. We supply parts and filters for all of our current and legacy products, as well as products from other manufacturers.

- Control Panels
 - Doors
 - Ductwork
 - Electrical Components
 - Fans
 - Filters
- Filter Racks
 - Grates and Pans
 - Hardware
 - Insulation
 - Lighting
 - Motors
- Oven Components
 - Spray Booth Accessories
 - Replacement Panels
 - Other Miscellaneous Parts



FILTERS

GFS paint booths are furnished with a complete set of GFS Wave exhaust filters. Replacement filters can be ordered from GFS to keep your booth operating in peak condition.

The most versatile single-stage paint booth filters, GFS Wave filters accommodate all paints and a wide array of spray applications. Lab testing indicates a 99.85% particulate removal efficiency, and field testing boasts excellent performance and reliability.



LIGHTS

GFS manufactures all standard light fixtures in our Osseo, Wisconsin facility. Replacement light fixtures and/or tubes for your paint booth can be purchased from GFS.

In addition to our standard 4-tube fluorescent light fixtures, GFS offers additional light fixtures, including:

- 6-tube light fixtures
- 3 ft. fixtures
- Rear-access light fixtures
- Explosion-proof light fixtures (fluorescent or incandescent)
- Corner light fixtures

Options:

- 3 stage NESHAP system, chromate removal
- Roll media
- Filter hooks
- Intake frames
- Filter grids and grid tips

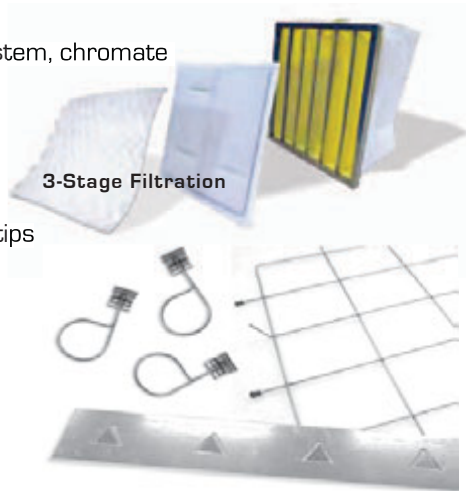

Filter Accessories

3 ft. Fixture



Explosion-Proof Fixture



Incandescent Fixtures



ELECTRONIC COMPONENTS AND CONTROL PACKAGES

	Part No.	Description
Start/Stop	127-221	Explosion Proof Heavy-duty, front-operated start/stop button can be mounted directly on booth. Use with motor starters.



	127-219	General Purpose NEMA Type 1 start/stop with N.O.-N.C. contacts. Must be mounted in non-hazardous locations. Use with motor starters.
--	---------	--



	650-003	Pneumatic This system activates a pneumatic-electric interface start/stop switch that turns the exhaust fan on/off. A non-sparking, pneumatic switch is located inside the spray booth, allowing the operator to enter and leave the booth with the exhaust fan turned off. This prevents dirty, unfiltered air from entering the paint area.
--	---------	---



Light Switches	650-001	Explosion Proof Front-operated on/off switch used in hazardous locations. One pole will handle 1400W- AC. Use with lights.
-----------------------	---------	--



	650-002	General Purpose On/off switch used in non-hazardous locations. Will handle 1400W- AC. Use with lights.
--	---------	--



Limit Switches
Electronically operated light switches shut down the painting operations when booth doors are opened. Time delay relay allows access to the booth without stopping operations. Interior shutdown switch stops painting operations from inside.

242-012 CL 1, Div. 1 Explosion Proof Switch	242-014 CL 1, Div. 2 Standard Switch
--	--



Air Proving Switch - Kit KIT-AP	Automatic pressure switch measures air pressure at the exhaust chamber. Recommended for use with Safety Air Valve. Kit includes Air Pressure Switch and Tube Kit
---	---



	Part No.	Description
3-Way Safety Air Valve	242-124	3/4" Ports 3-port, 2-position air valve prevents spraying with air-assist systems when light lens is open or exhaust fan is off. Compressed air between valve and spray equipment is vented out when exhaust is shut off. 120 Volt coil.



	242-019	1/2" Ports 3-port, 2-position air valve prevents spraying with air-assist systems when light lens is open or exhaust fan is off. Compressed air between valve and spray equipment is vented out when exhaust is shut off. 120 Volt coil.
--	---------	--



Safety Shut-Down
System automatically turns off compressed air to the spray gun when paint accumulation in the exhaust filters reaches a pre-set load point that prevents proper airflow through the booth. Complies with fire, health and insurance code requirements.

	600-003 600-008	Standard System 1/2" safety valve 3/4" safety valve
	600-004 600-007	Standard System w/Alarm 1/2" safety valve 3/4" safety valve
	600-005	Explosion Proof System 1/2" safety valve



	600-035	Gun Hanger Automatically starts up ventilation when the spray gun is lifted from the hanger, and shuts down the exhaust system when the spray gun is returned to the hanger. Explosion proof. Class 1, Division 1.
--	---------	--



Booth Gauges	242-001	Manometer/Draft Gauge Indicates when paint arrestors or air intake filters have become sufficiently loaded and need replacement. Meets code compliance. Included with all exhaust chambers and booths.
---------------------	---------	--



		Control Packages: Includes fused disconnect with fuses, magnetic motor starter with overloads & 120 volt control coil, push button motor starter, 1/2" air solenoid valve with 120 volt coil, and 120 or 277 volt light switch. Some booths may require multiple control packages based on the fan configuration.
--	--	---



CONTROLS

S = Standard Feature
◆ = Optional Feature

Notes:
• 6-light maximum capacity for standard panels
• 480 Volt systems with suffix - 4 use 277 Volt for light fixtures
• 230/208 Volt systems use 110 Volt for light fixtures
• Not recommended for spray booths with air makeup units or air balancing systems.

	Type 1 enclosure	Type 12 enclosure	Type 4 enclosure	Type 7 enclosure	Main disconnect	Main breaker disconnect	Magnetic motor starter	Exhaust Variable Frequency Drive	Motor fuse protection	Lighting contactor	Lighting fuse protection	System operating controls	Terminal strip for field wiring	System operation lights	Air replacement temp selector	Paint/Cure switch	System start-up interlock timer	Purge timer	Hour meter	Digital temp readout	Air balance control system	Dirty filter interlock	Air solenoid contact (Interlock) (Air Solenoid not included)	Door limit switch interlock	Air proving interlock	Infrared heat controls	UL industrial listing	Panel view touch screen	Programmable Logic Controller (PLC)	Gun hanger switch
Standard Control Panel	S				S	S		S	S	S	S	S	S	S								◆	S	◆	◆		S			
Standard Control Panel with Power Saver feature		S	◆	◆	S			S	S	S	S	S	S	S			S		◆			◆	S	◆	◆		S			S
Deluxe Control Panel (Pressurized Booth)		S	◆	◆		S	S	◆	S	S	S	S	S	S	S	◆	S	◆	◆	◆	◆	◆	S	S	◆	◆	S	◆	◆	
Deluxe Control Panel w/ Economizer feature		S	◆	◆		S		S	S	S	S	S	S	S	S	S	S	S	◆	◆	S	◆	S	S	◆	◆	S	◆	S	S



Standard Control Panel
Prewired, standard control panel features single-point connection for quick and easy wiring with NEMA rated enclosure.



Deluxe Control Panels
Are for special applications such as booths with air makeup units, multiple booth operations or booths with automatic air balancing systems. Each control panel is designed for a single point wiring connection. All control wires are numbered for easy wire identification. All components are labeled to match electrical schematic. Includes terminal strip for field wiring.

For Non Pressurized Spray Booths



Power Saver is a control panel upgrade that allows the painter to slow the exhaust fan to half speed when not painting. Included is a variable frequency drive (VFD), which controls the fan motor speed, and a gun hanger switch, which is wired to the control panel. When the painter hangs the spray gun on the hook, the VFD will slow the fan to half speed. When the paint gun is taken off the hook, the fan returns to full speed.

Energy is conserved in two ways:

- Fan motor uses less electricity
- Booth exhausts less heated air during the cold months

Can reduce airflow 50% during energy saving mode!

NOTE: In cases where an air makeup unit accompanies a non-pressurized spray booth, Power Saver will only control the spray booth.



The Consta-Flow System is designed to automatically adjust the exhaust fan to the changing conditions of the exhaust filters. GFS recommends Consta-Flow for all paint booths with conveyor openings and booths with multiple filter stages that have high static pressure when loading.

Consta-Flow consists of a VFD, differential pressure gauge and sensing probes. The system monitors static pressure and adjusts the exhaust fans RPMs to what is needed for the volume of exhaust air, based on how loaded the filters are. The result is a booth with constant airflow as filters load up with paint, increasing filter life.

For Pressurized Spray Booths



Economizer is a control panel upgrade for booths that have air makeup units directly pressurizing the booth. The upgrade includes an auto-balance system, VFD and gun hanger switch. The VFD automatically adjusts the airflow of the exhaust fan(s) to ensure proper booth balance. The gun hanger switch, located inside the paint booth, controls the booth function from paint mode to energy saving mode. When the paint gun is hanging on the hook, the booth airflow slows to half speed. When the paint gun is removed from the hook, airflow resumes to full speed.

Economizer can only be used on new or existing booths with variable air volume air makeup units.

Can reduce airflow 50% during energy saving mode!

A control panel purchased with Economizer will also automatically receive an Auto-Balance System, which keeps the booth balanced regardless of filter loading.



Recommended for all pressurized booths, Auto Balance is designed to keep the paint booth balanced while in operation. The system consists of a VFD, differential pressure gauge and sensing probes.

The Auto Balance System monitors the interior booth pressure and adjusts the exhaust fan RPMs to what is needed for the volume of exhaust air, based on what the incoming intake air is. The result is a booth that is balanced automatically and stays in balance as the filters load up with paint overspray. The system increases useful filter life, provides a constant airflow throughout the booth, and allows you to easily control the booth pressure.

Request a Control Panel Quote

New booth quote: Provide the following information to receive a quote for the Energy Saving control panel with your booth request: indicate 3- or Single-phase power, electrical voltage in the shop where the booth will be located, 3- or 4-wire electrical system.

Existing booth quote: Provide the following information to receive a quote for a control panel to upgrade an existing booth: Exhaust fan motor HP and how many fan motors, number of lights on the booth, indicate 3- or Single-phase power, electrical voltage in the shop where the booth will be located, 3- or 4-wire electrical system.

AUTOMATIC ROOF VENTILATORS

Design provides automatic protection against rain, snow and backdraft for the exhaust system, spray booth and operator. All sizes are constructed from galvanized steel.



Part No.	Diameter
DU-ARV-12-	12"
DU-ARV-18-	18"
DU-ARV-24-	24"
DU-ARV-30-	30"
DU-ARV-34-	34"
DU-ARV-36-	36"
DU-ARV-40-	40"
DU-ARV-42-	42"
DU-ARV-48-	48"

ELBOWS

Full radius throat and pipe diameter construction allows for a smooth interior surface. Minimized airflow resistance, turbulence and exhaust air noise management is superior versus others, and can be utilized in most applications. All sizes are constructed from galvanized steel.



Part No.	Part No.	Diameter
45°	90°	
DU-E45M-12-	DU-E90M-12-	12"
DU-E45M-18-	DU-E90M-18-	18"
DU-E45M-24-	DU-E90M-24-	24"
DU-E45M-30-	DU-E90M-30-	30"
DU-E45M-34-	DU-E90M-34-	34"
DU-E45M-36-	DU-E90M-36-	36"
DU-E45M-40-	DU-E90M-40-	40"
DU-E45M-42-	DU-E90M-42-	42"
DU-E45M-48-	DU-E90M-48-	48"

PLAIN EXHAUST DUCT

Straight, 3 ft long section, with one end corrugated for easy installation. Duct can be ordered with a removable Access Door (CD) used for inspection and cleaning.



All sizes are constructed from galvanized steel. Requires some assembly.

Part No.	Diameter
DU-PLP-12-3-	12"
DU-PLP-18-3-	18"
DU-PLP-24-3-	24"
DU-PLP-30-3-	30"
DU-PLP-34-3-	34"
DU-PLP-36-3-	36"
DU-PLP-40-3-	40"
DU-PLP-42-3-	42"
DU-PLP-48-3-	48"

STANDARD SPIRAL DUCT

Available in 4 ft. or 8 ft. lengths. All sizes are constructed from galvanized steel. Will require connector rings on each end.



Part No.	Diameter
DU-SPP-12-	12"
DU-SPP-18-	18"
DU-SPP-24-	24"
DU-SPP-30-	30"
DU-SPP-34-	34"
DU-SPP-36-	36"
DU-SPP-40-	40"
DU-SPP-42-	42"
DU-SPP-48-	48"

EXHAUST STACK KITS

Exhaust Stack Kits include: (3) 3 ft. Plain Exhaust Duct sections, (1) 3 ft. Universal Stack with Access Door, and (1) Roof Ventilator.



Part No.	Diameter
DU-STK-12	12"
DU-STK-18	18"
DU-STK-24	24"
DU-STK-30	30"
DU-STK-34	34"
DU-STK-36	36"
DU-STK-40	40"
DU-STK-42	42"
DU-STK-48	48"

GUY WIRE KITS

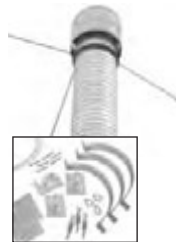

Includes 50 feet of 1/8" cable, anchors, turnbuckles and clamps for installation of three guy wires to above roof exhaust stack.

Part No.	Diameter
DU-GWK-12	12"
DU-GWK-18	18"
DU-GWK-24	24"
DU-GWK-30	30"
DU-GWK-34	34"
DU-GWK-36	36"
DU-GWK-40	40"
DU-GWK-42	42"
DU-GWK-48	48"

Note: Connector ring sold separately.

CONNECTOR RINGS



Used for connecting the exhaust fan to other exhaust stack components. Connector ring price is not included in duct pricing, unless indicated. Indicate the number of rings, and if rings are to be welded to duct or shipped loose. One connector ring is supplied with fan assemblies, as standard.

Part No.	Diameter
409-112	12"
409-118	18"
409-124	24"
409-130	30"
409-134	34"
409-136	36"
409-140	40"
409-142	42"
409-148	48"

ROOF FLANGES

Not recommended for corrugated metal roofs. GFS recommends a custom curb on a roof pitch that exceeds 4" on 12; specify pitch when ordering.



Part No.	Part No.	Diameter
Flat	Pitched	
DU-FRF-12-WC	DU-PRF-12-__-WC	12"
DU-FRF-18-WC	DU-PRF-18-__-WC	18"
DU-FRF-24-WC	DU-PRF-24-__-WC	24"
DU-FRF-30-WC	DU-PRF-30-__-WC	30"
DU-FRF-34-WC	DU-PRF-34-__-WC	34"
DU-FRF-36-WC	DU-PRF-36-__-WC	36"
DU-FRF-40-WC	DU-PRF-40-__-WC	40"
DU-FRF-42-WC	DU-PRF-42-__-WC	42"
DU-FRF-48-WC	DU-PRF-48-__-WC	48"

For additional Accessories contact GFS Parts & Filters:

- Fan Stands
- Motor Covers
- Mufflers
- Custom Ductwork
- Automatic Shutters

EXHAUST DUCTWORK INSTALLATION

Different components are used to make up the systems shown. The diagrams below illustrate how the different components are used to make up the several systems. All motor and fan locations must be decided before installation, to ensure proper hardware is equipped with the booth. For unusual applications consult GFS for recommendations.

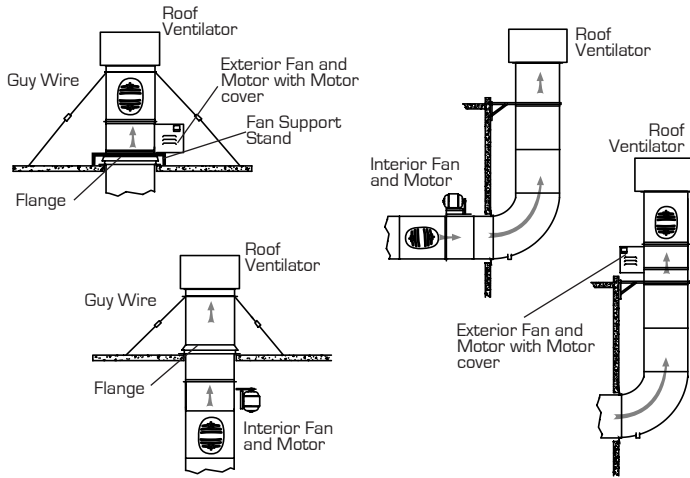

SIZES: 18", 24", 30, 34" & 40"

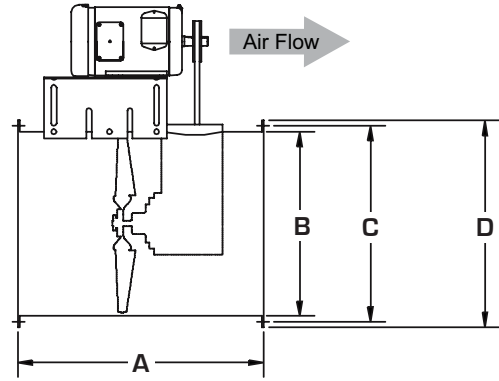

Model	A Ring to Ring	B Inside Dim.	C Mounting Bolt	D Outside Dim.
GFA-18	24"	18"	19 1/4"	20 1/2"
GFA-24	24"	24"	25 1/2"	26 7/8"
GFA-30	30"	30"	31 3/4"	33"
GFA-34	30"	34"	35 3/4"	37"
GFA-40	30"	40"	41 3/4"	43"

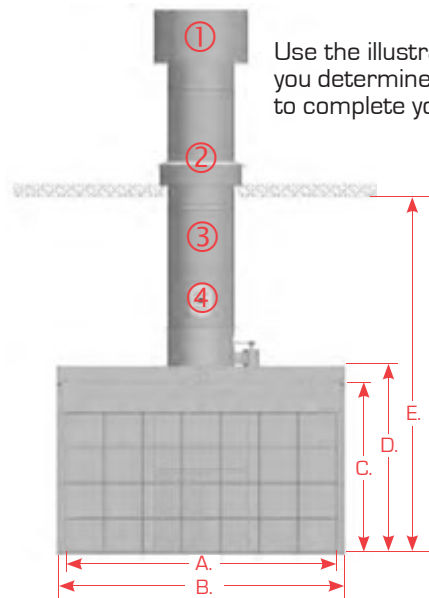

Use the illustrations and charts to help you determine the components needed to complete your system.

Note: Check with your local area inspector for code compliance. The stack should be cleaned periodically depending on usage. This will insure efficient operation and lessen the danger of fire when combustible materials have been used.

Duct Work	Qty	Dia.
① Automatic Roof Ventilator		
② Roof Flange with Collar (Pitch: _____" on 12)		
③ Plain Exhaust Duct (36" length)		
④ Plain Exhaust Duct with Clean-Out Door (36" length)		

Booth Measurements	Feet	Inches
A. Working Width		
B. Overall Booth Width		
C. Working Height		
D. Overall Booth Height		
E. Roof Height		

SIZES: 12", 18", 24", 30", 36", 42" & 48"

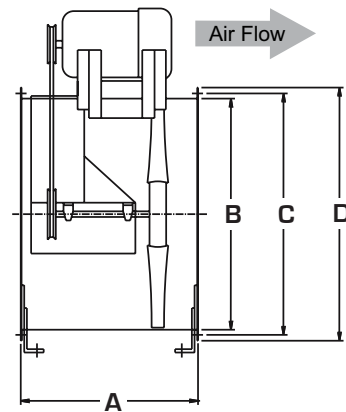

Model	A Ring to Ring	B Inside Dim.	C Mounting Bolt	D Outside Dim.
TAB-12	18"	12.25	14.00	14.88
TAB-18	22"	18.38	19.75	21.63
TAB-24	23"	24.38	25.75	27.63
TAB-30	24"	30.38	32.00	33.63
TAB-36	29"	36.38	38.00	39.63
TAB-42	30"	42.50	44.25	45.75
TAB-48	33"	48.50	50.75	52.75



GLOBAL FINISHING SOLUTIONS

FROM AMERICA'S HEARTLAND TO YOUR FRONT DOOR

Made in Wisconsin, USA



All of GFS' products are fully designed and manufactured in our Osseo, Wisconsin facility. With a strong history in manufacturing, Wisconsin is home to a large and diversified economy. Among good company, some of America's largest manufacturers have placed their roots in this state, including Briggs & Stratton, Harley-Davidson, Johnson Controls, Mercury Marine, Oshkosh and Rockwell Automation.



With more than 200,000 square feet of manufacturing space and state-of-the-art equipment, GFS has the capacity and talent to build our booths from scratch. Virtually every part of our products are built in our shop, including the sheet steel, control panels, lights and hinges.

GLOBAL FINISHING SOLUTIONS • **800-848-8738** • info@globalfinishing.com

WWW.GLOBALFINISHING.COM



Scan this QR Code to
link to our website.