

VECTOR™ R SERIES CASCADE APPLICATORS

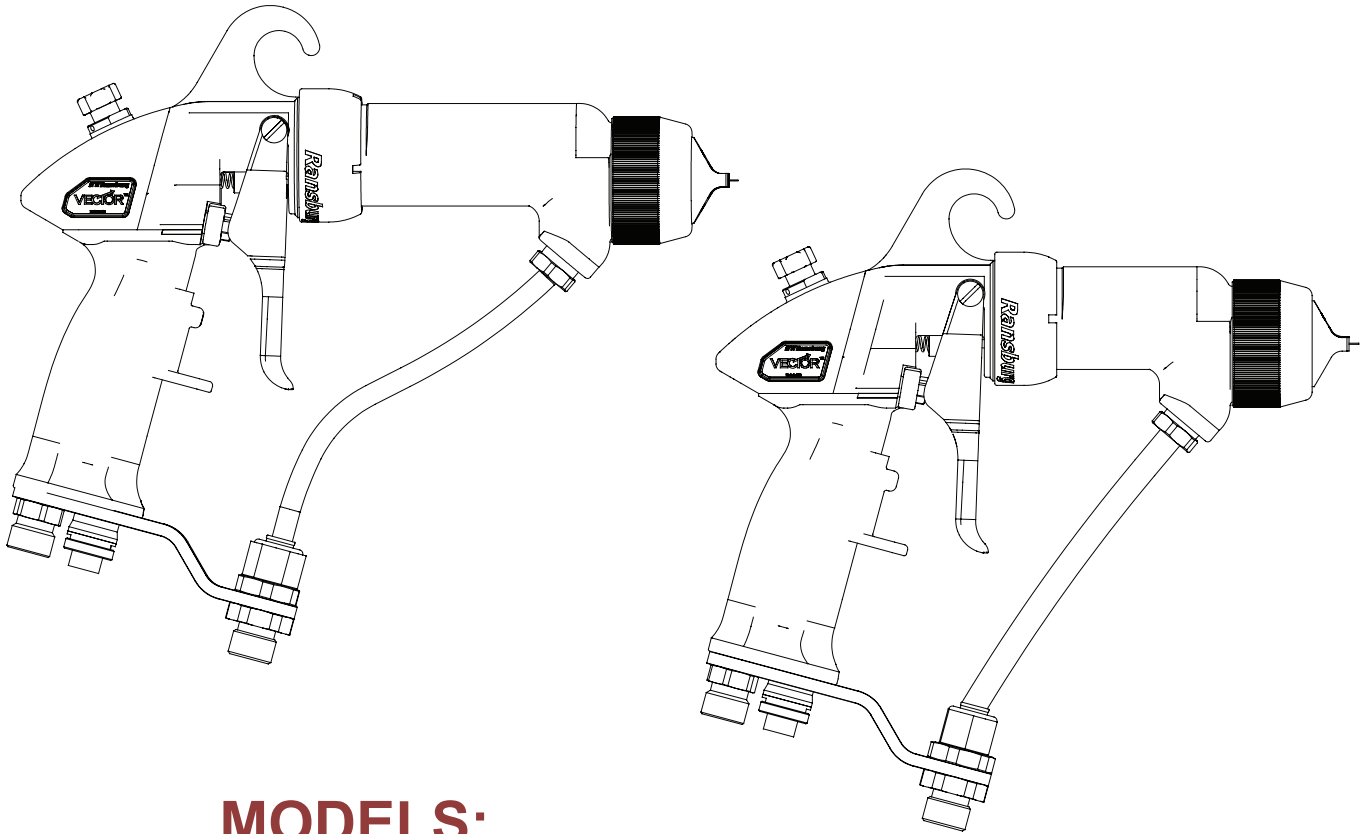

MODELS:

79500 R90 Cascade - Solventborne

79501 R70 Cascade - Solventborne

79523 R90 Cascade - Waterborne 

For Use With 80131-xxx Control Unit



IMPORTANT: Before using this equipment, carefully read SAFETY PRECAUTIONS, starting on page 1, and all instructions in this manual. Keep this Service Manual for future reference.

Service Manual Price:

\$50.00 (U.S.)

NOTE: This manual has been changed from revision AH-06-01.12 to revision AH-06-01.13. Reasons for this change are noted under “Manual Change Summary” inside the back cover of this manual.

CONTENTS

	PAGE
SAFETY:	
	1-4
SAFETY PRECAUTIONS	1
HAZARDS / SAFEGUARDS	2-4
ATEX/FM:	
	5-12
EUROPEAN ATEX DIRECTIVE	5
EUROPEAN ATEX LABELS	6
FM CONFIGURATION DRAWINGS	7-12
INTRODUCTION:	
	13-17
GENERAL DESCRIPTION	13
79500 R90 CASCADE SOLVENTBORNE SPECIFICATIONS	14
79501 R70 CASCADE SOLVENTBORNE SPECIFICATIONS	14
R90/70 CASCADE SOLVENTBORNE ELECTROSTATIC SPRAY APPLICATOR FEATURES	15
80131-XXX 9060 POWER SUPPLY ELECTRICAL SPECIFICATIONS	16
80131-XXX CASCADE CONTROL UNIT FEATURES	17
INSTALLATION:	
	18-25
79500 R90 / 79501 R70 SOLVENTBORNE INSTALLATION	18
TYPICAL SOLVENTBORNE INSTALLATION	18-20
LOW VOLTAGE CABLE	21
FILTERS	21
AIR HOSE RECOMMENDATION.....	22
FLUID HOSE RECOMMENDATION	22
AIR AND FLUID HOSE INSTALLATION	22
ROUTING OF AIR FLUID HOSES	22
PAINT PREPARATION	23
SPRAY PATTERN ADJUSTMENT	23
APPLICATOR TO TARGET DISTANCE	23
FLUID NOZZLE / AIR CAP SELECTION CHARTS	24-25
ROUND SPRAY PERFORMANCE CHART	25
OPERATION:	
	26-31
POWERING UP CONTROL UNIT	26
SETPOINT VOLTAGE	26-27
LOCKOUTS	27-28
KV TEST JUMPER	29
BASIC OPERATION	29-30
FAULT DESCRIPTIONS	30

(Continued On Next Page)

CONTENTS (Cont.)

	PAGE
MAINTENANCE:	31-50
SUITABLE SOLVENTS FOR CLEANING VECTOR R90/70 APPLICATORS	31
ROUTINE SCHEDULE	32
APPLICATOR ASSEMBLY CLEANING PROCEDURE	33-34
FLUSHING PROCEDURES	35
APPLICATOR REPAIR	35
TO REMOVE THE APPLICATOR FROM THE WORK SITE	36
AIR CAP	36-37
FLUID NOZZLE	37-38
NEEDLE / ELECTRODE	38
NEEDLE / ELECTRODE RESISTANCE TESTING	39
BARREL ASSEMBLY	39-40
DISASSEMBLY / REASSEMBLY OF BARREL WITH THE 2K FLUID NEEDLE PACKINGS	40-44
HANDLE / PLUG ASSEMBLY	45-47
TROUBLESHOOTING GUIDE	48-50
PARTS IDENTIFICATION:	51-71
R90/70 CASCADE SOLVENTBORNE APPLICATOR BREAKDOWN / PARTS LIST	51-54
VECTOR R90/70 CASCADE SOLVENTBORNE MODEL IDENTIFICATION	54
R90 (78628-11) AND R70 (78628-12) CASCADE NEEDLE SHAFT (STANDARD PACKINGS) / PARTS LIST	55
R90 (79599-01) AND R70 (79599-02) CASCADE NEEDLE SHAFT PARTS LIST	56
WATERBORNE APPLICATOR MODEL 79523 SECTION	
- R90 CASCADE WATERBORNE ELECTROSTATIC SPRAY APPLICATOR FEATURES	58
- 79523 R90 CASCADE WATERBORNE SPECIFICATIONS	59
- 79513-1XX 9050 POWER SUPPLY ELECTRICAL SPECIFICATIONS	59
- R90 CASCADE WATERBORNE TYPICAL INSTALLATION	60
- WATERBORNE ISOLATION SYSTEM INSTALLATION GUIDELINES	61
- WATERBORNE HOSE FITTING INSTALLATION	61-63
- WATERBORNE FLUID DELIVERY COMPONENTS / PARTS LIST	64
- VECTOR R90 CASCADE WATERBORNE MODEL IDENTIFICATION	65
VECTOR AIR HOSE OPTIONS / PARTS LIST	66
VECTOR FLUID HOSE OPTIONS / PARTS LIST	66
VECTOR APPLICATOR COVER OPTIONS / PARTS LIST	67
VECTOR SWIRL NOZZLE OPTIONS / PARTS LIST	67
VECTOR FLUID TUBE OPTIONS / PARTS LIST	67
LOW VOLTAGE CABLE OPTION / PARTS LIST	67
PARTS COMPARISON / TRANS-TECH. ATOMIZATION / PARTS LIST	68
79555 TRANS-TECH. CONVERSION KITS AVAILABLE	69
ACCESSORIES FOR ECON FLUSH BOX COMPATIBILITY (OPTIONAL)	69
VECTOR CASCADE APPLICATORS RECOMMENDED SPARE PARTS	70-71
WARRANTY POLICIES:	72
LIMITED WARRANTY	72

SAFETY

SAFETY PRECAUTIONS

Before operating, maintaining or servicing any Ransburg electrostatic coating system, read and understand all of the technical and safety literature for your Ransburg products. This manual contains information that is important for you to know and understand. This information relates to **USER SAFETY** and **PREVENTING EQUIPMENT PROBLEMS**. To help you recognize this information, we use the following symbols. Please pay particular attention to these sections.

A WARNING! States information to alert you to a situation that might cause serious injury if instructions are not followed.

A CAUTION! States information that tells how to prevent damage to equipment or how to avoid a situation that might cause minor injury.

A NOTE is information relevant to the procedure in progress.

While this manual lists standard specifications and service procedures, some minor deviations may be found between this literature and your equipment. Differences in local codes and plant requirements, material delivery requirements, etc., make such variations inevitable. Compare this manual with your system installation drawings and appropriate Ransburg equipment manuals to reconcile such differences.

Careful study and continued use of this manual will provide a better understanding of the equipment and process, resulting in more efficient operation, longer trouble-free service and faster, easier troubleshooting. If you do not have the manuals and safety literature for your Ransburg system, contact your local Ransburg representative or Ransburg.



WARNING



- The user **MUST** read and be familiar with the Safety Section in this manual and the Ransburg safety literature therein identified.
- This hand held device is intended to be used by trained personnel **ONLY**.
- This manual **MUST** be read and thoroughly understood by **ALL** personnel who operate, clean or maintain this equipment! Special care should be taken to ensure that the **WARNINGS** and safety requirements for operating and servicing the equipment are followed. The user should be aware of and adhere to **ALL** local building and fire codes and ordinances as well as **NFPA-33 EN 50176 SAFETY STANDARD**, or applicable country safety standards prior to installing, operating, and/or servicing this equipment.





WARNING

- The hazards shown on the following page may occur during the normal use of this equipment. Please read the hazard chart beginning on page 2.

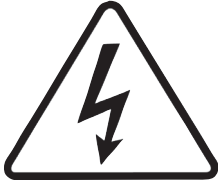
<p>AREA Tells where hazards may occur.</p>	<p>HAZARD Tells what the hazard is.</p>	<p>SAFEGUARDS Tells how to avoid the hazard.</p>
<p>Spray Area</p> 	<p>Fire Hazard</p> <p>Improper or inadequate operation and maintenance procedures will cause a fire hazard.</p> <p>Protection against inadvertent arcing that is capable of causing fire or explosion is lost if any safety interlocks are disabled during operation. Frequent power supply shutdown indicates a problem in the system requiring correction.</p>	<p>Fire extinguishing equipment must be present in the spray area and tested periodically.</p> <p>Spray areas must be kept clean to prevent the accumulation of combustible residues.</p> <p>Smoking must never be allowed in the spray area.</p> <p>The high voltage supplied to the atomizer must be turned off prior to cleaning, flushing or maintenance.</p> <p>When using solvents for cleaning:</p> <p>Those used for equipment flushing should have flash points equal to or higher than those of the coating material.</p> <p>Those solvents used for cleaning must have a flash point at minimum of 5°C (9°F) greater than the ambient temperature. It is the end users responsibility to insure this condition is met.</p> <p>Spray booth ventilation must be kept at the rates required by local and/or country codes. In addition, ventilation must be maintained during cleaning operations using flammable or combustible solvents.</p> <p>Electrostatic arcing must be prevented.</p> <p>Test only in areas free of combustible material.</p> <p>Testing may require high voltage to be on, but only as instructed.</p> <p>Non-factory replacement parts or unauthorized equipment modifications may cause fire or injury.</p> <p>If used, the key switch bypass is intended for use only during setup operations. Production should never be done with safety interlocks disabled.</p> <p>The paint process and equipment should be set up and operated in accordance with local and/or country safety codes.</p>

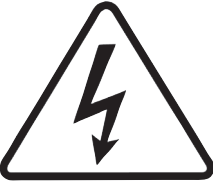
<p>AREA Tells where hazards may occur.</p>	<p>HAZARD Tells what the hazard is.</p>	<p>SAFEGUARDS Tells how to avoid the hazard.</p>
<p>Toxic Substances</p> 	<p>Certain material may be harmful if inhaled, or if there is contact with the skin.</p>	<p>Follow the requirements of the Material Safety Data Sheet supplied by coating material manufacturer.</p> <p>Adequate exhaust must be provided to keep the air free of accumulations of toxic materials.</p> <p>Use a mask or respirator whenever there is a chance of inhaling sprayed materials. The mask must be compatible with the material being sprayed and its concentration. Equipment must be as prescribed by an industrial hygienist or safety expert, and be approved.</p>
<p>Explosion Hazard / Incompatible Materials</p> 	<p>Halogenated hydrocarbon solvents, for example: methylene chloride and 1,1,1, - Trichloroethane, are not chemically compatible with the aluminum that might be used in many system components. The chemical reaction caused by these solvents reacting with aluminum can become violent and lead to an equipment explosion.</p>	<p>Spray applicators require that aluminum inlet fittings be replaced with stainless steel. (See "Accessories" in the "Parts Identification" section.) Aluminum is widely used in other spray application equipment - such as material pumps, regulators, valves, etc. Check all other equipment items before use and make sure they can also be used safely with these solvents. Read the label or data sheet for the material you intend to spray. If in doubt as to whether or not a coating or cleaning material is compatible, contact your material supplier. Any other type of solvent may be used with aluminum equipment.</p>
<p>Electrical Equipment</p> 	<p>High voltage equipment is utilized. Arcing in areas of flammable or combustible materials may occur. Personnel are exposed to high voltage during operation and maintenance.</p> <p>Protection against inadvertent arcing that may cause a fire or explosion is lost if safety circuits are disabled during operation.</p> <p>An electrical arc can ignite coating materials and cause a fire or explosion.</p>	<p>Turn the power module OFF before working on the equipment.</p> <p>Test only in areas free of flammable or combustible material.</p> <p>Testing may require high voltage to be on, but only as instructed.</p> <p>Production should never be done with the safety circuits disabled.</p> <p>Before turning the high voltage on, make sure no objects are within the sparking distance.</p>

<p>AREA Tells where hazards may occur.</p>	<p>HAZARD Tells what the hazard is.</p>	<p>SAFEGUARDS Tells how to avoid the hazard.</p>
<p>Spray Area</p> 	<p>Electrostatic Arcing</p>	<p>Never operate the applicator without properly grounding the following.</p> <p>A. Operators</p> <p>Operators must be grounded. Rubber soled insulating shoes should not be worn. Grounding leg or wrist straps may be used.</p> <p>Operators must maintain contact with the handle of the applicator. If work gloves are used, the palm section must be cut out.</p> <p>Operators must remove from themselves all metal objects that are not grounded.</p> <p>NOTE: REFER TO NFPA-33, EN 50176 REGARDING OPERATOR GROUNDING OR SPECIFIC COUNTRY SAFETY CODE.</p> <p>B. Parts being sprayed. Resistance between the part and a grounded conveyor must not exceed 1 megohm.</p> <p>C. Every metal and conductive object in the spray area. This includes the booth, parts hangers, fire extinguishers, conductive flooring, etc.</p> <p>Grounded conductive flooring must be provided in the spray area.</p> <p>Turn off voltage at the power module before flushing out, cleaning, or removing any parts from the applicator.</p> <p>Never install an applicator into a fluid system using an isolated solvent supply.</p> <p>Do not touch applicator electrode while applicator is energized.</p>
<p>General Use and Maintenance</p> 	<p>Improper operation or maintenance may create a hazard.</p> <p>Personnel must be properly trained in the use of this equipment.</p>	<p>Personnel must be given training in accordance with the requirements of NFPA-33, EN 50176.</p> <p>Instructions and safety precautions must be read and understood prior to using this equipment.</p> <p>Comply with appropriate local, state, and national codes governing ventilation, fire protection, operation maintenance, and housekeeping.</p>

EUROPEAN ATEX DIRECTIVE 94/9/EC, ANNEX II, 1.0.6

The following instructions apply to equipment covered by certificate number Sira08ATEX5060X:

1. The equipment may be used with flammable gases and vapors with apparatus groups II and with temperature class T6.

2. The equipment is only certified for use in ambient temperatures in the range +0°C to +40°C and should not be used outside this range.

3. Installation shall be carried out by suitably trained personnel in accordance with the applicable code of practice e.g. EN 60079-14:1997.

4. Inspection and maintenance of this equipment shall be carried out by suitably trained personnel in accordance with the applicable code of practice e.g. EN 60079-17.

5. Repair of this equipment shall be carried out by suitable trained personnel in accordance with the applicable code of practice e.g. EN 60079-19.

6. Putting into service, use, assembling, and adjustment of the equipment shall be fitted by suitably trained personnel in accordance with the manufacturer's documentation.

Refer to the "Table of Contents" of this service manual:

- a. Installation
- b. Operation
- c. Maintenance
- d. Parts Identification

7. Components to be incorporated into or used as replacement parts of the equipment shall be fitted by suitably trained personnel in accordance with the manufacturer's documentation.

8. The certification of this equipment relies upon the following materials used in its construction:

If the equipment is likely to come into contact with aggressive substances, then it is the responsibility of the user to take suitable precautions that prevent it from being adversely affected, thus ensuring that the type of protection provided by the equipment is not compromised.

Aggressive substances: e.g. acidic liquids or gases that may attack metals, or solvents that may affect polymeric materials.

Suitable precautions: e.g. regular checks as part of routine inspections or establishing from the material's data sheets that it is resistant to specific chemicals.

Refer to "Specifications" in the "Introduction" section:

- a. All fluid passages contain stainless steel or nylon fittings.
- b. High voltage cascade is encapsulated with a solvent resistant epoxy.

9. A recapitulation of the certification marking is detailed in the "ATEX" section, on the next page, drawing numbers: 79846-01 and 79852-01.

10. The characteristics of the equipment shall be detailed e.g. electrical, pressure, and voltage parameters.

The manufacturer should note that, on being put into service, the equipment must be accompanied by a translation of the instructions in the language or languages of the country in which the equipment is to be used and by the instructions in the original language.

VECTOR R SERIES 79500, 79501, AND 79523 ATEX PRODUCT MARKING DEFINITIONS

Ex Certificate Number: Sira 06ATEX5282X

Sira = Notified Body performing EC-type examination

06 = Year of certification

ATEX = Reference to ATEX Directive

5 = Protection Concept Code (code 5 is titled Encapsulation)

282 = Document serial number

X = Special conditions for safe use apply

Special conditions for safe use: The Vector 79500, 79501, and 79523 R Series Cascade Applicators shall only be used with associated 80131-21X Control Unit.

Product Marking



Ex = Specific marking of explosive protection
II = Equipment Group hazardous area characteristics

2 = Equipment Category

G = Type of explosive atmosphere (gases, vapors, or mists)

EEx 0.24mJ = The Vector R Series 79500, 79501, and 79523 Cascade Applicators are suitable for use in manual spraying installations complying with EN 50 050 as they are a Type A class with a discharge energy limit of 0.24mJ.



Label 80082



Label 80081

Label 79515

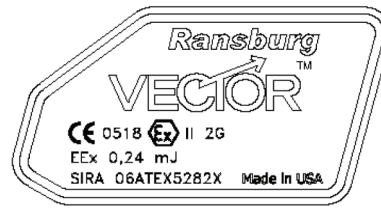

Label 79516-70

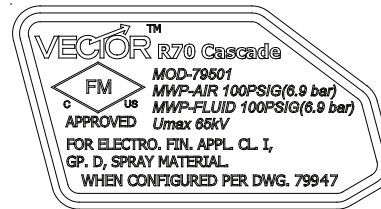

Label 79516-91

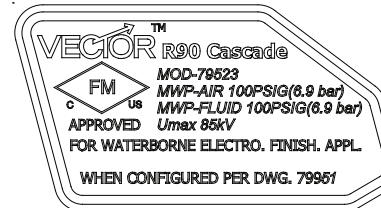

Label 79516-90

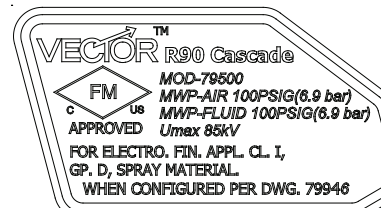

Label 80108

Ransburg BRAND OF FINISHING BRANDS HOLDINGS, INC. TOLEDO, OH.		CONTROL UNIT/POWER SUPPLY FOR ELECTROSTATIC PAINT FINISHING APPLICATIONS (SERIAL NUMBER HOLLOWAY DATE OF MANUFACTURE)	
WARNING FAILURE TO OBSERVE THE FOLLOWING PRECAUTIONS MAY RESULT IN AN ELECTRICAL DISCHARGE CAPABLE OF STARTING A FIRE.		PART No. _____ SERIAL No. _____	
1. THE ARTICLE BEING COATED MUST BE GROUNDED.		VOLTAGE	1 A. MAX. INPUT RMP CURRENT
2. ALL OTHER ELECTRICALLY CONDUCTING OBJECTS WITHIN SPRAY BOOTH WITH THE SPRAY APPLICATOR MUST BE GROUNDED.		FREQUENCY	1 PHASES
3. THIS CONTROL UNIT/POWER SUPPLY MUST BE INTERLOCKED WITH THE SPRAY BOOTH VENTILATORS SO AS TO PREVENT OPERATION OF THE POWER SUPPLY UNLESS VENTILATING FANS ARE IN OPERATION.		VOLTAGMS	MAX. OUTPUT VOLTAGE
4. SERVICE WARNING- ENCLOSURE PROTECTS AGAINST SHOCK AND INJURY. SERVICE TRAINING REQUIRED.		HUMIDITY	MAX. OUTPUT CURRENT
5. KEEP POWER SUPPLY OUTSIDE THE HAZARDOUS AREA.		TEMP. PRESSURE	TEMPERATURE
6. DO NOT ATTEMPT OPERATION OR REPAIR BEFORE READING SERVICE MANUAL.			
7. FOR ELECTROSTATIC PAINT FINISHING APPLICATIONS.			

FM Configuration

These applicators are FM approved when configured to drawings 79946, 79947, 79951, shown on pages 7 thru 12.

VECTOR R90 CASCADE, SOLVENT BASED

79500 - ABCDE

BASE OPTION
MODEL NO. DESIGNATIONS
(ORDERING INFORMATION ONLY)

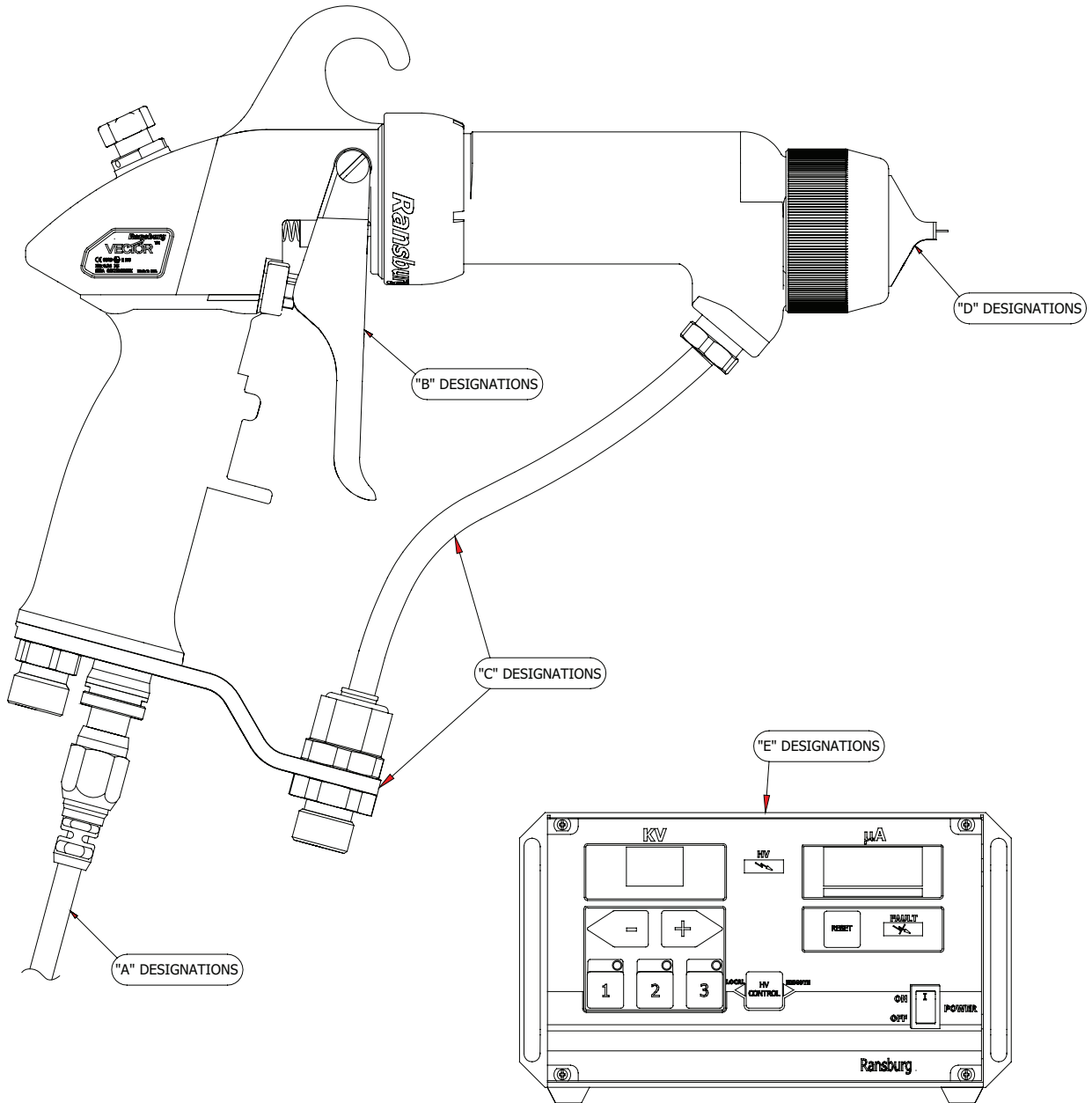

CONFIGURATION DWG. 79946 REV B

OPTION "A" DESIGNATIONS
CABLE LENGTH

- 0 FOR NO CABLE
- 1 FOR 10 METER CABLE-PART NUMBER: 79338-10
- 2 FOR 15 METER CABLE-PART NUMBER: 79338-15
- 3 FOR 20 METER CABLE-PART NUMBER: 79338-10 (2)
- 4 FOR 25 METER CABLE-PART NUMBER: 79338-10 (1) & 79338-15 (1)
- 5 FOR 30 METER CABLE-PART NUMBER: 79338-15 (2)

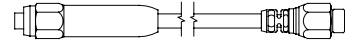

OPTION "B" DESIGNATIONS
TRIGGER TYPE

- 2 FOR TWO FINGER TRIGGER-PART NUMBER: 79325-02
- 4 FOR FOUR FINGER TRIGGER-PART NUMBER: 79325-04

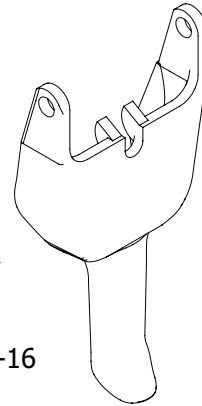

OPTION "C" DESIGNATIONS
FLUID DELIVERY COMBINATION

- 1 OFFSET WITH .093" ID FLUID TUBE-PART NUMBER: 79438-00 & 9704-16
- 2 45° WITH .093" ID FLUID TUBE-PART NUMBER: 79439-00 & 9704-16
- 3 OFFSET STAINLESS WITH .093" ID FLUID TUBE-PART NUMBER: 79438-01 & 9704-16
- 4 OFFSET WITH .250" ID FLUID TUBE-PART NUMBER: 79438-00 & 9704-11
- 5 45° WITH .250" ID FLUID TUBE-PART NUMBER: 79439-00 & 9704-11
- 6 OFFSET STAINLESS WITH .250" ID FLUID TUBE-PART NUMBER: 79438-01 & 9704-11
- 7 OFFSET WITH .125" ID COILED FLUID TUBE-PART NUMBER: 79438-00 & 79871-00

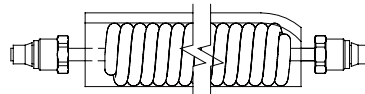
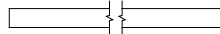
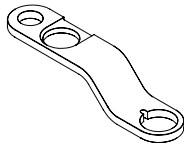

OPTION "D" DESIGNATIONS
SPRAY TECHNOLOGY

- 0 FOR STANDARD SPRAY, 65V CAP, #44 NOZZLE-PART NUMBER: 79374-65 & 79377-44
- 1 FOR STANDARD SPRAY, 65V CAP, #45 NOZZLE-PART NUMBER: 79374-65 & 79377-45
- 2 FOR TRANSTECH SPRAY, 122V CAP, #245 NOZZLE-PART NUMBER: 79374-122 & 79552-245
- 3 FOR ROUND SPRAY-PART NUMBER: 79962-00 & 79959-00

APPROVED SPARE FLUID NOZZLES LIST

- 79377-46 (1.06mm ID, STD. WEAR), 79377-47 (.71mm ID, STD. WEAR),
- 79377-48 (1.19mm ID, STD. WEAR), 79377-144 (1.40mm ID, HIGH WEAR),
- 79377-145 (1.78mm ID, HIGH WEAR), 79377-146 (1.06mm ID, HIGH WEAR),
- 79377-147 (.71mm ID, HIGH WEAR), 79552-244 (1.40mm ID, STD. WEAR),
- 79552-344 (1.40mm ID, HIGH WEAR), 79552-345 (1.78mm ID, HIGH WEAR)



OPTION "E" DESIGNATIONS
CONTROL UNIT

- 0 FOR NO CONTROL UNIT
- 1 FOR DOMESTIC SALES, 110/120 V-PART NUMBER: 80131-311
- 2 FOR EUROPE, 240V-50/60 Hz -PART NUMBER: 80131-312
- 3 FOR CHINA, 240V-50/60 Hz - PART NUMBER: 80131-313

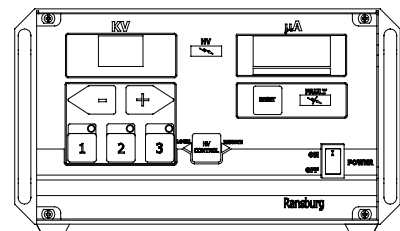

CONFIGURATION DWG. 79946 REV B

VECTOR R70 CASCADE, SOLVENT BASED

79501 - ABCDE

BASE OPTION
MODEL NO. DESIGNATIONS
(ORDERING INFORMATION ONLY)

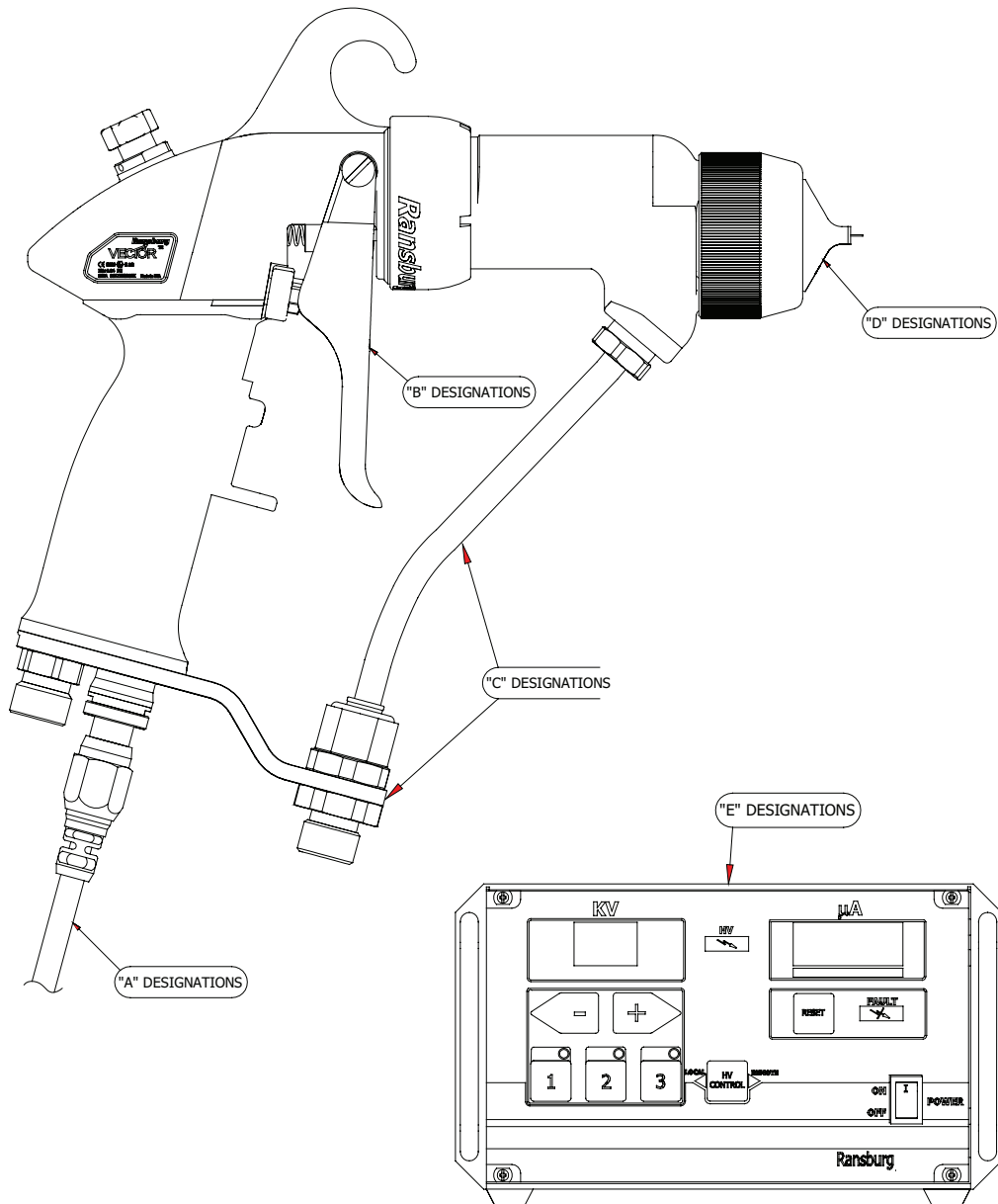

CONFIGURATION DWG. 79947 REV B

OPTION "A" DESIGNATIONS
CABLE LENGTH

- 0 FOR NO CABLE
- 1 FOR 10 METER CABLE-PART NUMBER: 79338-10
- 2 FOR 15 METER CABLE-PART NUMBER: 79338-15
- 3 FOR 20 METER CABLE-PART NUMBER: 79338-10 (2)
- 4 FOR 25 METER CABLE-PART NUMBER: 79338-10 (1) & 79338-15 (1)
- 5 FOR 30 METER CABLE-PART NUMBER: 79338-15 (2)

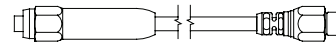

OPTION "B" DESIGNATIONS
TRIGGER TYPE

- 2 FOR TWO FINGER TRIGGER-PART NUMBER: 79325-02
- 4 FOR FOUR FINGER TRIGGER-PART NUMBER: 79325-04

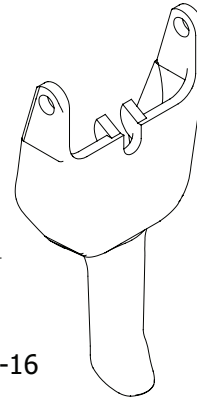

OPTION "C" DESIGNATIONS
FLUID DELIVERY COMBINATION

- 1 OFFSET WITH .093" ID FLUID TUBE-PART NUMBER: 79438-00 & 9704-16
- 2 45° WITH .093" ID FLUID TUBE-PART NUMBER: 79439-00 & 9704-16
- 3 OFFSET STAINLESS WITH .093" ID FLUID TUBE-PART NUMBER: 79438-01 & 9704-16
- 4 OFFSET WITH .250" ID FLUID TUBE-PART NUMBER: 79438-00 & 9704-11
- 5 45° WITH .250" ID FLUID TUBE-PART NUMBER: 79439-00 & 9704-11
- 6 OFFSET STAINLESS WITH .250" ID FLUID TUBE-PART NUMBER: 79438-01 & 9704-11
- 7 OFFSET WITH .125" ID COILED FLUID TUBE-PART NUMBER: 79438-00 & 79871-00

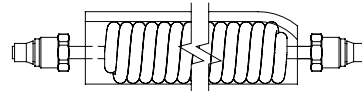
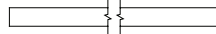
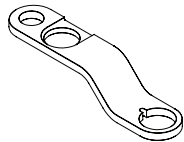

OPTION "D" DESIGNATIONS
SPRAY TECHNOLOGY

- 0 FOR STANDARD SPRAY, 65V CAP, #44 NOZZLE-PART NUMBER: 79374-65 & 79377-44
- 1 FOR STANDARD SPRAY, 65V CAP, #45 NOZZLE-PART NUMBER: 79374-65 & 79377-45
- 2 FOR TRANSTECH SPRAY, 122V CAP, #245 NOZZLE-PART NUMBER: 79374-122 & 79552-245
- 3 FOR ROUND SPRAY-PART NUMBER: 79962-00 & 79959-00

APPROVED SPARE FLUID NOZZLES LIST

- 79377-46 (1.06mm ID, STD. WEAR), 79377-47 (.71mm ID, STD. WEAR),
- 79377-48 (1.19mm ID, STD. WEAR), 79377-144 (1.40mm ID, HIGH WEAR),
- 79377-145 (1.78mm ID, HIGH WEAR), 79377-146 (1.06mm ID, HIGH WEAR),
- 79377-147 (.71mm ID, HIGH WEAR), 79552-244 (1.40mm ID, STD. WEAR),
- 79552-344 (1.40mm ID, HIGH WEAR), 79552-345 (1.78mm ID, HIGH WEAR)

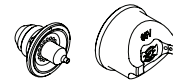

OPTION "E" DESIGNATIONS
CONTROL UNIT

- 0 FOR NO CONTROL UNIT
- 1 FOR DOMESTIC SALES, 110/120 V-PART NUMBER: 80131-211
- 2 FOR EUROPE, 240V-50/60 Hz -PART NUMBER: 80131-212
- 3 FOR CHINA, 240V-50/60 Hz - PART NUMBER: 80131-213

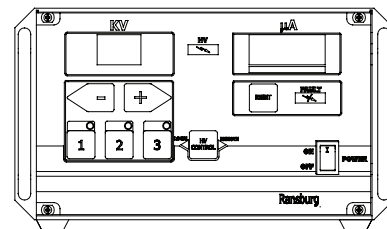

CONFIGURATION DWG. 79947 REV B

VECTOR R90 CASCADE, WATER BASED

79523 - ABCDE

BASE OPTION
MODEL NO. DESIGNATIONS
(ORDERING INFORMATION ONLY)

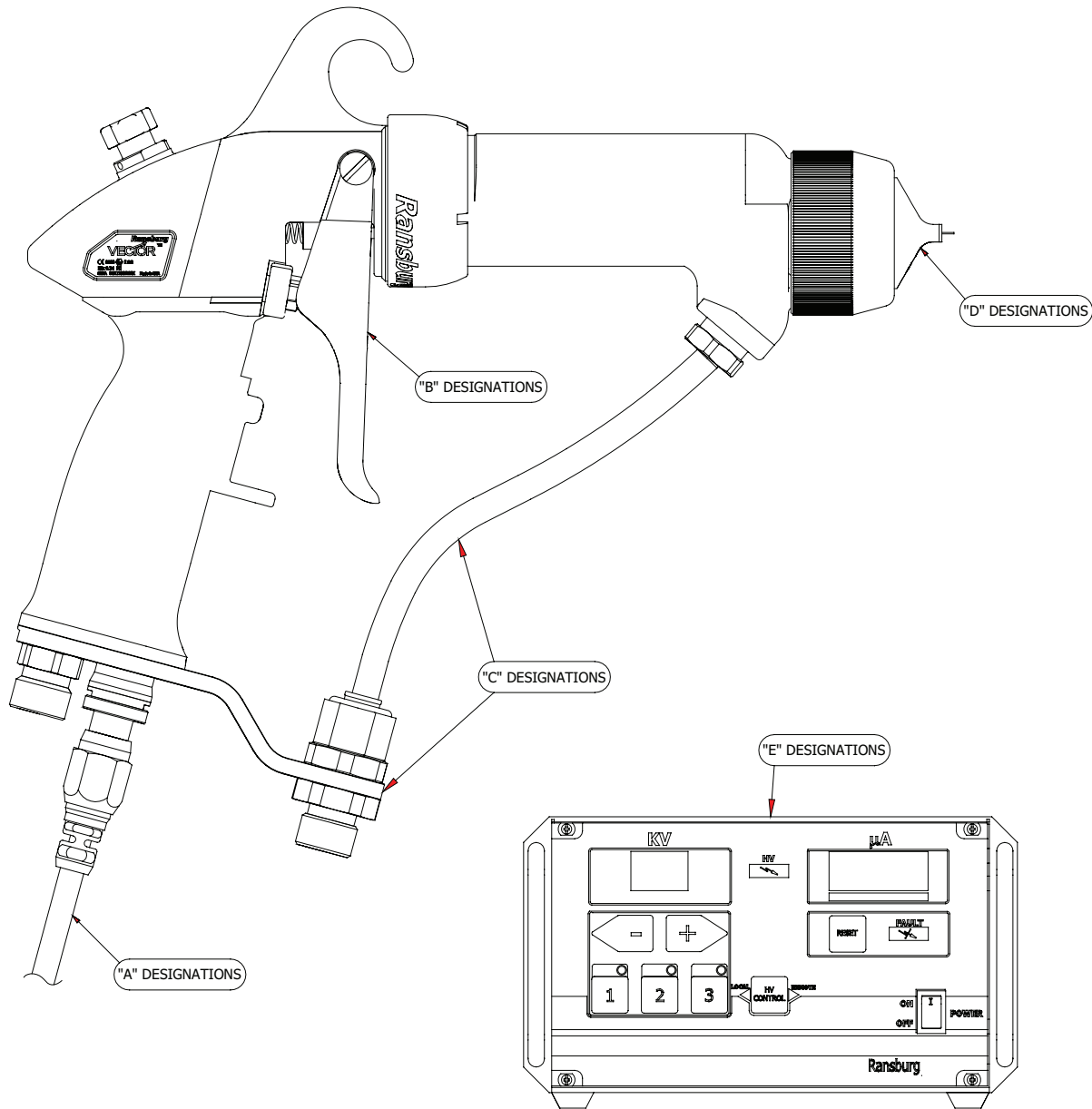

CONFIGURATION DWG. 79951 REV B

OPTION "A" DESIGNATIONS
CABLE LENGTH

- 0 FOR NO CABLE
- 1 FOR 10 METER CABLE-PART NUMBER: 79338-10
- 2 FOR 15 METER CABLE-PART NUMBER: 79338-15
- 3 FOR 20 METER CABLE-PART NUMBER: 79338-10 (2)
- 4 FOR 25 METER CABLE-PART NUMBER: 79338-10 (1) & 79338-15 (1)
- 5 FOR 30 METER CABLE-PART NUMBER: 79338-15 (2)

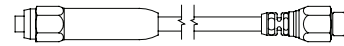

OPTION "B" DESIGNATIONS
TRIGGER TYPE

- 2 FOR TWO FINGER TRIGGER-PART NUMBER: 79325-02
- 4 FOR FOUR FINGER TRIGGER-PART NUMBER: 79325-04

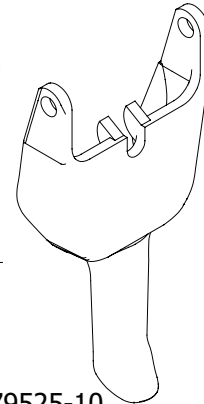

OPTION "C" DESIGNATIONS
FLUID HOSE LENGTH & TYPE

- 0 FOR NO FLUID HOSE
- 1 FOR WATERBORNE FLUID HOSE-1/4" ID X 10m (30ft)-PART NUMBER: 79525-10
- 2 FOR WATERBORNE FLUID HOSE-3/16" ID X 10m (30ft)-PART NUMBER: 79524-10
- 3 FOR WATERBORNE FLUID HOSE-1/4" ID X 15m (50ft)-PART NUMBER: 79525-15
- 4 FOR WATERBORNE FLUID HOSE-3/16" ID X 15m (50ft)-PART NUMBER: 79524-15

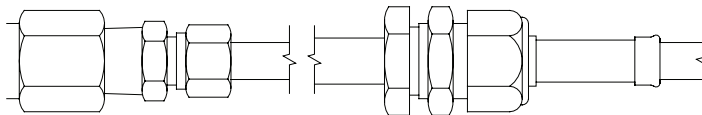

OPTION "D" DESIGNATIONS
SPRAY TECHNOLOGY

- 0 FOR STANDARD SPRAY, 65V CAP, #44 NOZZLE-PART NUMBER: 79374-65 & 79377-44
- 1 FOR STANDARD SPRAY, 65V CAP, #45 NOZZLE-PART NUMBER: 79374-65 & 79377-45
- 2 FOR TRANSTECH SPRAY, 122V CAP, #245 NOZZLE-PART NUMBER: 79374-122 & 79552-245
- 3 FOR ROUND SPRAY-PART NUMBER: 79962-00 & 79959-00

APPROVED SPARE FLUID NOZZLES LIST

- 79377-46 (1.06mm ID, STD. WEAR), 79377-47 (.71mm ID, STD. WEAR),
- 79377-48 (1.19mm ID, STD. WEAR), 79377-144 (1.40mm ID, HIGH WEAR),
- 79377-145 (1.78mm ID, HIGH WEAR), 79377-146 (1.06mm ID, HIGH WEAR),
- 79377-147 (.71mm ID, HIGH WEAR), 79552-244 (1.40mm ID, STD. WEAR),
- 79552-344 (1.40mm ID, HIGH WEAR), 79552-345 (1.78mm ID, HIGH WEAR)



OPTION "E" DESIGNATIONS
CONTROL UNIT

- 0 FOR NO CONTROL UNIT
- 1 FOR DOMESTIC SALES, 110/120 V-PART NUMBER: 80131-511
- 2 FOR EUROPE, 240V-50/60 Hz -PART NUMBER: 80131-512
- 3 FOR CHINA, 240V-50/60 Hz - PART NUMBER: 80131-513

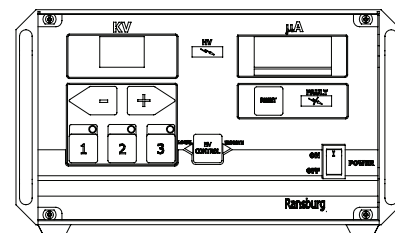

CONFIGURATION DWG. 79951 REV B

INTRODUCTION

GENERAL DESCRIPTION

The **Vector™ R90/70 Spray Applicator** process is an air-atomized method for electrostatically applying product coatings. The Vector R90/R70 Spray Applicator system applies a high voltage DC charge to the applicator electrode, creating an electrostatic field between the atomizer and the target object.

Vector™ R90 Cascade Spray Applicator (see Figure 1) applies a -85 kV DC charge to the coating materials at the point of atomization. The **Vector™ R70 Cascade Spray Applicator** applies a -65 kV charge. This electrostatic charge allows a more efficient, uniform application of coating material to the front, edges, sides, and back of products. It is highly suitable for applying coatings to a variety of surface configurations: large targets, small parts, tubular wares, concave and recessed parts, etc. Because it is a grounded fluid system (for solvent based systems), it is highly suitable for applying a wide range of solvent reduced coatings such as enamels, lacquers, epoxies, etc. The 79523 model is available to accommodate waterborne materials.

A regulated pressure fluid system delivers coating material to the atomizer. At the time of triggering the applicator, fan and atomization air is introduced, which atomizes the coating material into a spray mist. The atomized spray particles under the influence of the electrostatic field become electrically charged. The charged particles are attracted to, and deposited on, the target object. The forces between the charged particles and the grounded target are sufficient to turn most normal overspray around and deposit it on the back surface of the target. Therefore, a high percentage of the coating is deposited on the target.

One of the many features of the Vector R90/70 applicator system is that the electrical energy, which is available from the resistive charging electrode, is limited to the optimum level of safety and efficiency. The system is incapable of releasing sufficient electrical or thermal energy during normal operating conditions to cause ignition of specific hazardous materials in their most easily ignited concentrations in air.

The control unit or power supply provides voltage output to the applicator and contains controls for AC on/off, high voltage adjust, and displays kV and μ A in real time.

As the applicator electrode approaches ground, the control unit and applicator circuitry cause the high voltage to approach zero while the current approaches its maximum value.

WARNING

- When more than one waterborne applicator is fed from a common isolated fluid supply, there is a potential for electrical energy discharge through any other applicators when one applicator is triggered. Depending upon the system capacity, this discharge could be hazardous. It is best to only install one applicator per isolated supply.

**79500 R90 CASCADE
SOLVENTBORNE
SPECIFICATIONS**

Environmental/Physical

Gun Length:	27cm (10.7 inches)
Weight:	735 grams (25.9 oz.)
Hose & Cable Lengths (Std):	10m, 15m, 20m, 25m, and 30m
Atomizer Nozzle Assembly (Std):	79374-65, 79377-45

Electrical

Operating Voltage:	85 kV DC (-) maximum
Current Output:	100 microamperes maximum
Paint Resistance:*	.1 MΩ to ∞ *(Use Model No. 76652, Test Equipment)
Part Sprayability:	Determine sprayability of part to be coated using 76652, Test Equipment (See current "Paint, HV & SCI Test Equipment" service manual.)

Mechanical

Fluid Flow Capacity:	1000 cc/minute**
Operating Pressure (Air Spray)	
Fluid:	(0-6.9 bar) 0-100 psi
Air:	(0-6.9 bar) 0-100 psi
Ambient Temp.:	40°C to 12.8°C
Consumption:	510 slpm (18 SCFM) @ 3.4 bar (50 psig) inlet
Sound Level:	92dB (A) @ 50 psig inlet, 1m from applicator

** This reflects the maximum fluid volume the applicator can deliver. The maximum spray volume that can be effectively atomized depends on fluid rheology, spray technology, and finish quality required.

**79501 R70 CASCADE
SOLVENTBORNE
SPECIFICATIONS**

Environmental/Physical

Gun Length:	24cm (9.6 inches)
Weight:	650 grams (22.9 oz.)
Hose & Cable Lengths (Std):	10m, 15m, 20m, 25m, and 30m
Atomizer Nozzle Assembly (Std):	79374-65, 79377-45

Electrical

Operating Voltage:	65 kV DC (-) maximum
Current Output:	90 microamperes maximum
Paint Resistance:*	.1 MΩ to ∞ *(Use Model No. 76652, Test Equipment)
Part Sprayability:	Determine sprayability of part to be coated using 76652, Test Equipment (See current "Paint, HV & SCI Test Equipment" service manual.)

Mechanical

Fluid Flow Capacity:	1000 cc/minute**
Operating Pressure (Air Spray)	
Fluid:	(0-6.9 bar) 0-100 psi
Air:	(0-6.9 bar) 0-100 psi
Ambient Temp.:	40°C to 12.8°C
Consumption:	510 slpm (18 SCFM) @ 3.4 bar (50 psig) inlet
Sound Level:	92dB (A) @ 50 psig inlet, 1m from applicator

** This reflects the maximum fluid volume the applicator can deliver. The maximum spray volume that can be effectively atomized depends on fluid rheology, spray technology, and finish quality required.

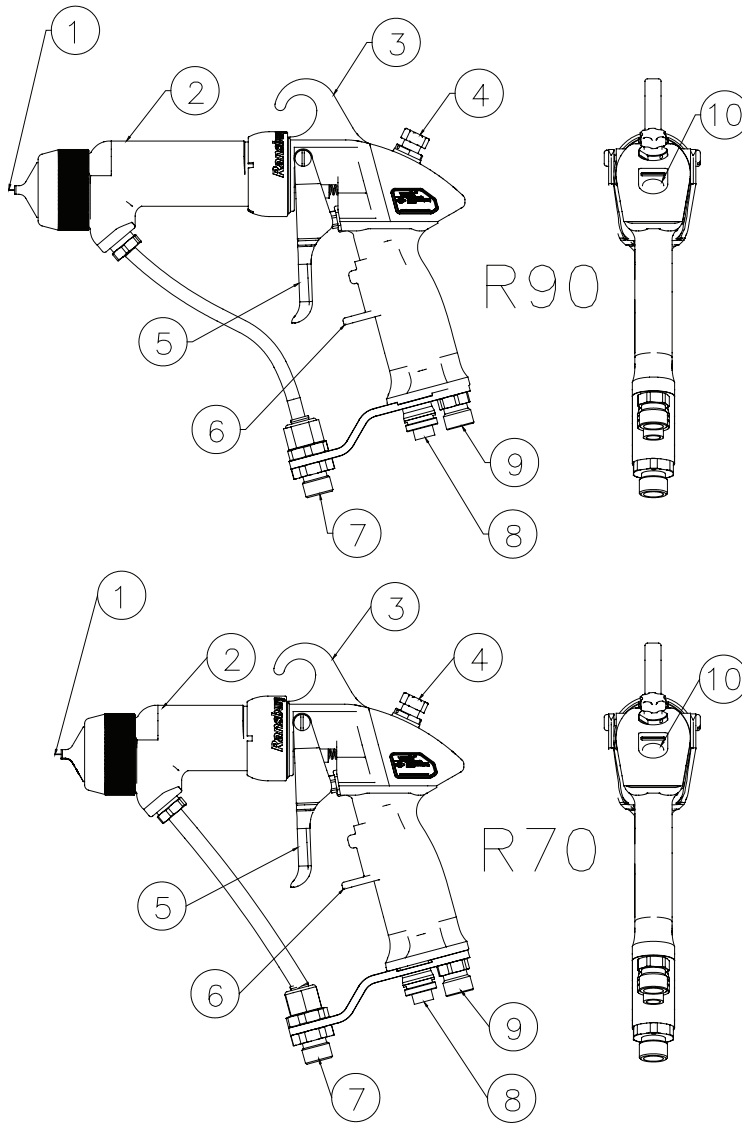

Figure 1: R90/70 Cascade Solventborne Electrostatic Spray Applicator Features

R90/70 CASCADE SOLVENTBORNE ELECTROSTATIC SPRAY APPLICATOR FEATURES			
No.	Description	No.	Description
1	Needle/Electrode	6	Adjustable Trigger Shelf
2	Barrel	7	Fluid Hose Connection
3	Replaceable Hook	8	Low Voltage Cable Connection
4	Fan Air Adjust	9	Air Inlet Connection
5	2-Finger/4-Finger Trigger	10	kV Setpoint Switch/Microamp Display

80131-XXX 9060 POWER SUPPLY ELECTRICAL SPECIFICATIONS

Electrical

Input Voltage:	100-240 VAC
Current:	1 A max. RMS
Frequency:	50/60 Hz
Wattage:	40 watts (max.)
Output Voltage:	20-65 kV DC (79513-11X) 20-85 kV DC (79513-12X)
Current:	100 microamps (max.) (79513-12X) 90 microamps (max.) (79513-11X)

Physical

Height:	14.0cm (5.5-inches)
Width:	21.6cm (8.5-inches)
Depth:	19.1cm (7.5-inches)
Weight:	3.4 kg (7.5 lbs.)

Pneumatic

Supply Air:	6.9 bar (100 psig) maximum
--------------------	----------------------------

CONTROL UNIT INPUTS / OUTPUTS		
9060 Part #	Voltage Designation	Maximum Output
80131-211	110/120 VAC	-65 kV DC
80131-212/213	220/240 VAC	-65 kV DC
80131-311	110/120 VAC	-85 kV DC
80131-312/313	220/240 VAC	-85 kV DC

CONTROL UNIT / APPLICATOR COMBINATIONS	
9060 Part #	For Use With
80131-21X	79501-XXXXX
80131-31X	79500-XXXXX
80131-51X	79523-XXXXX

Plug Styles

80131-XXX

- 1 USA/Canada
- 2 Europe
- 3 China

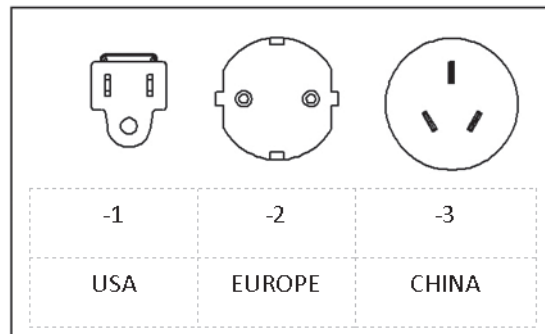

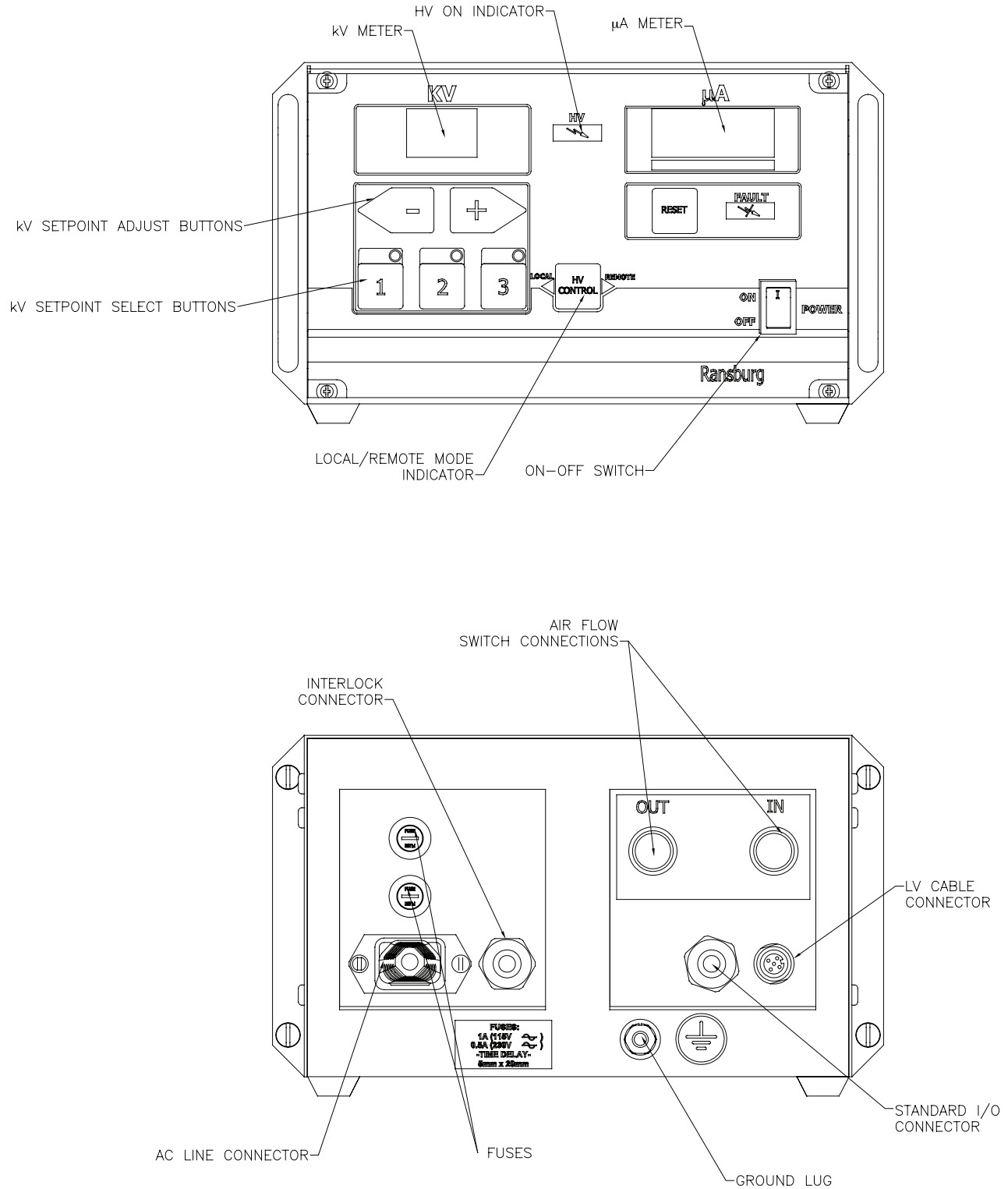

Figure 2: 80131-XXX Cascade Control Unit Features

INSTALLATION

79500 R90 SOLVENTBORNE 79501 R70 SOLVENTBORNE INSTALLATION

! WARNING

- The control unit **MUST** be located outside of the spray area.
- The User **MUST** read and be familiar with the "Safety" section of this manual.
- This manual **MUST** be read and thoroughly understood by **ALL** personnel who operate, clean, or maintain this equipment! Special care should be taken to ensure that the warnings and requirements for operating and servicing safety are followed. The user should be aware of and adhere to **ALL** local building and fire codes and ordinances as well as NFPA, OSHA, and all related country safety codes prior to installing, operating, and/or servicing this equipment.
- The fluid lines and fluid sources **MUST** be isolated from ground for waterbase applications.
- Personnel **MUST** be **GROUNDING** to prevent a shock or spark during electrostatic operation.
- Install and route the hoses and cable so they are **NOT** exposed to temperatures in excess of 120° F and so that all hose and cable bends are **NO LESS** than a 6 inch (15cm) radius. Failure to comply with these parameters could cause equipment malfunction that might create **HAZARDOUS CONDITIONS!**
- Install only one spray applicator per isolated waterborne fluid supply system.

! WARNING

- **NEVER** wrap the applicator, associated valves and tubing, and supporting hardware in plastic to keep it clean. A surface charge may build up on the plastic surface and discharge to the nearest grounded object. Efficiency of the applicator will also be reduced and damage or failure of the applicator components may occur. **WRAPPING THE APPLICATOR IN PLASTIC WILL VOID WARRANTY.** Only approved applicator covers should be used.

TYPICAL SOLVENTBORNE INSTALLATION

(See "Figure 3 - Typical Solventborne Installation Features")

Location of Control Unit

Install the low voltage control unit in an area **outside the hazardous location** in accordance with federal, state, and local codes. The area should protect the control unit from the possibility of environmental intrusion (such as dust or moisture), have ambient temperatures that do not exceed 120°F, and be as close to the applicator as possible to minimize the length of low voltage cable.

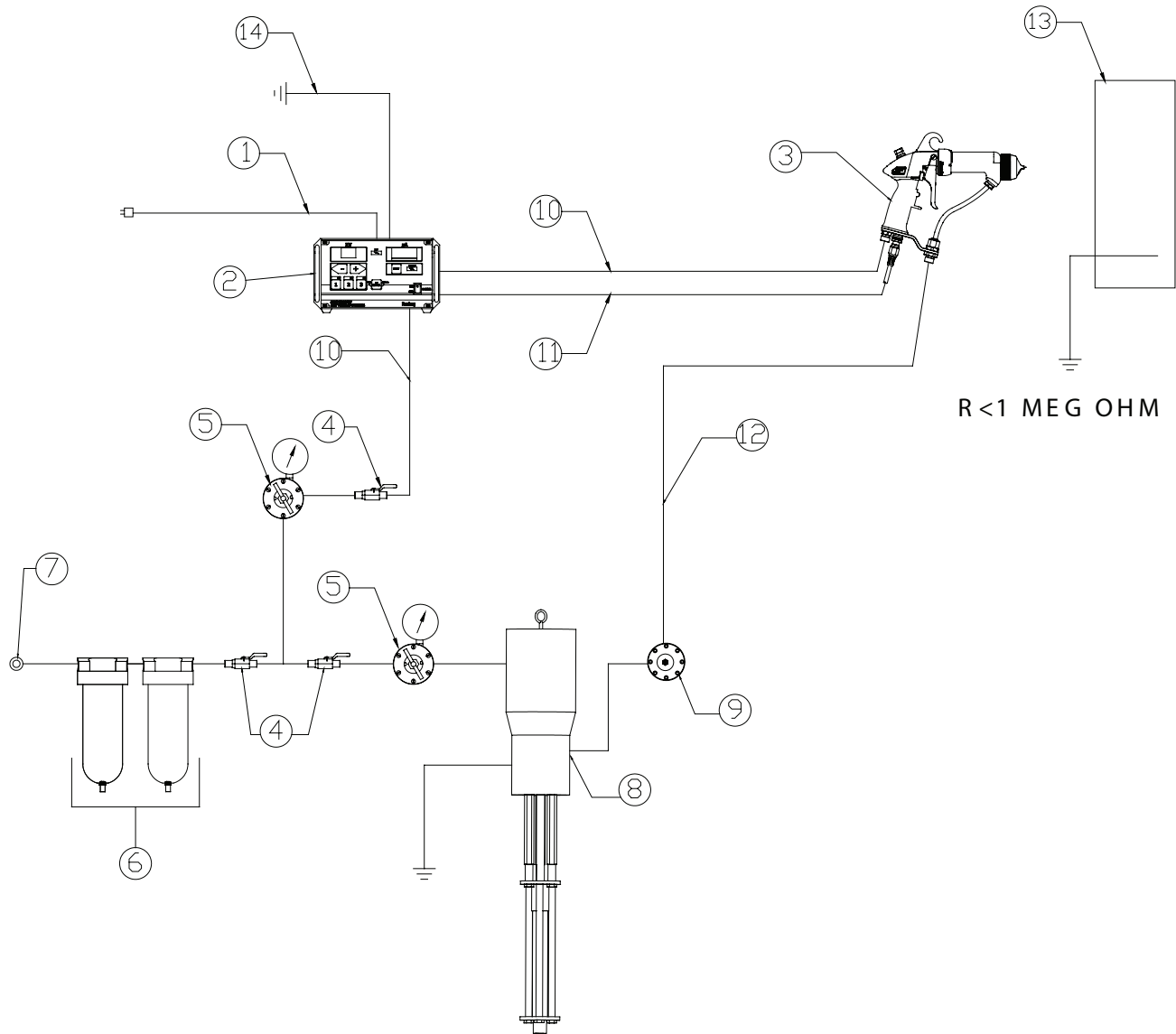

Figure 3: Typical Solventborne Installation Features

TYPICAL SOLVENTBORNE INSTALLATION FEATURES			
No.	Description	No.	Description
1	AC Line Cord (110/220)	8	Fluid Supply (Grounded)
2	9060 Control Unit	9	Fluid Regulator
3	Vector Applicator	10	Air Line
4	Ball Valve	11	Low Voltage Cable
5	Air Regulator W/Pressure Gauge	12	Fluid Line
6	Air/Water Separator	13	Target (Earth or Building Ground)
7	Main Air Supply Line	14	9060 Ground (Separate Earth or Building Ground)

The 9060 Control

Unit must be located a minimum of 5' (1.5 m) outside of what is considered to be the hazardous area. Any mounting method used must properly support the unit to a minimum of 4X the unit weight.

NOTE

- See manual CP-13-07 for the installation instructions for the 9060 control unit.



WARNING

- For safe use these applicators 79500, 79501 and 79523 must be used with the appropriate 9060 Control Unit part number 80131-XXX. For exact configurations see the approved configuration drawings in the front of this manual.

LOW VOLTAGE CABLE

Connect the low voltage cable from the control unit to the applicator using a wrench to tighten.

⚠ CAUTION

- ▶ **DO NOT** over-tighten the low voltage connection at the applicator. The plastic parts could be damaged.

With the Vector design, multiple cables may be connected together to create the length required, up to a maximum of 30m (100 ft.). To connect the cables, insert the male end of one cable into the female end of the other. Tighten both cable connectors against each other using two (2) 16mm (5/8") open-end wrenches.

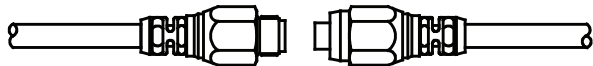

Figure 10: Daisy Chained Cable

⚠ WARNING

- ▶ The electrical discharge that is available from the charging electrode must not exceed 0.24 mJ of energy. To achieve this limit, any flow of energy from the paint supply through the paint line to the applicator electrode must be prevented by grounding the paint line at the applicator handle.

Verify that the applicator handle is actually grounded before operating it! This is done with a fully connected and operational system, by placing one lead of an ohmmeter to the handle and the other to the building electrical ground (cold water pipe, building structure, steel, etc.). This reading should be essentially zero.

If a greater reading is obtained, check that the control unit is grounded. (See the control unit manual for "Grounding Procedure.")

FILTERS

1. Install an air filter assembly on the air inlet of the control unit. The filter should be 5 micron with a maximum working pressure of at least 100 psig (6.9 bar). Screw the fitting into the filter inlet. The filter **MUST** be installed with the arrow pointing in the direction of flow. (Refer to the appropriate Filter Assembly manual for "Installation Instructions".)

When the applicator is triggered, the resulting air flow closes the contacts of the air flow switch, thereby activating high voltage at the applicator.

⚠ CAUTION

- ▶ An air filter **MUST** be installed to permit proper functioning of the air flow switch inside the control unit. This unit must filter particles 5 microns and larger.

2. Ransburg recommends that a fluid filter be installed at the output of the fluid supply (pressure pot, pump, circulating system, etc.). It is the end user's responsibility to install the proper filter that meets their system's requirements.

Air Hose Recommendation

Ransburg recommends using a 79547-XX air hose assembly that may be ordered through your authorized Ransburg distributor. This hose performs best with the Vector to reduce air hose stiffness along with weight reduction. Available hose lengths are listed in "Accessories" in the "Parts Identification" section of this manual.

 CAUTION
➤ Any user installed air hose must be rated for 100 psig (6.9 bar) working pressure minimum.

Fluid Hose Recommendation

Ransburg recommends using a 79548 fluid hose assembly. This assembly is made to specifically fit the fluid fitting size engineered into the applicator. This hose is available from your authorized Ransburg distributor. Available hose lengths are listed in "Accessories" in the "Parts Identification" section of this manual.

 CAUTION
➤ Any user installed fluid hose used must be rated for 100 psig (6.9 bar) working pressure minimum.

Air and Fluid Hose Installation

The fluid inlet fitting for the Vector applicator is 3/8-18 NPSM(M). When installing a fluid hose, tighten the fitting adequately to prevent any fluid leaks. The air inlet fitting is 1/4-18 NPSM(M). When installing the air hose, use a wrench to hold the air inlet fitting on the Vector and tighten the air hose fitting enough to prevent any air leaks.

Routing of Air and Fluid Hoses

Starting at the applicator, route the air hose along the same path as the low voltage cable to the low voltage control unit. The fluid hose can be run with the low voltage cable and air hose or it can be separate and run to the fluid source. Do not expose the hoses to high temperatures (over 120°F) and/or conditions such as moving parts, foot traffic, vehicle traffic, etc.

Prior to connecting the air hose to the low voltage unit and the fluid hose to the fluid supply, adjust the hose and low voltage cable position at the applicator to relieve some strain on the low voltage cable. To do this, perform the following procedure:

1. Disconnect the air hose from the applicator.
2. Position the air hose 1-inch (2.5cm) away from the bottom of the handle.
3. Secure the air hose to the low voltage cable. Secure the two together at one additional location, about 12-16-inches (30-41cm) back.
4. With a wrench, reconnect and secure the air hose to the applicator. (This should form a small loop in the low voltage cable.)
5. Secure the fluid hose to the air hose and low voltage cable as needed.

 WARNING
➤ When securing the air hose, fluid hose, and low voltage cable together, take care not to use items such as wire or anything that might cut into the hoses or cable. If wire ties are used, they should only be tight enough to secure the cable and not so tight that they might restrict fluid and air flow.

Adjust the length of the air hose to the low voltage controller and install the fitting to the hose.

PAINT PREPARATION

A proper paint mixture is essential to electrostatic operation. Paint test equipment may be obtained through your Ransburg distributor. Reference the Technical Manual "Paint Related Information for REA, REM, Vector, and M90 Guns" for paint formulation information. For further paint formulation and testing procedures, consult your Ransburg distributor and/or your paint supplier.

SPRAY PATTERN ADJUSTMENT

The spray pattern of fan atomizers is adjustable from a small circle to an elongated oval, approximately 10-18-inches of usable pattern when sprayed from a target distance of 8-12-inches. The swirl atomizer assemblies produce a round pattern from 4-6-inches in diameter. The fan control knob provides control of the pattern shaping air. Counter-clockwise expands the pattern and clockwise reduces it.

The Vector has a distinct feature that allows counting of clicks. The fan valve has 8 clicks per 1 full turn of the adjustment knob.

To change the spray pattern axis of fan atomizers from horizontal to vertical, loosen the air nozzle retaining ring, rotate the air cap clockwise to the desired position, and gently tighten the ring.

APPLICATOR TO TARGET DISTANCE

Hold the applicator 6-12-inches maximum from the target for best operation (higher transfer efficiency will be achieved at the closer target distance). Trigger the applicator fully to operate.

NOTE

- See the Ransburg bulletin "Handgun Spray Techniques".

FLUID NOZZLE SELECTION STD SPRAY CHART		
Fluid Nozzle Part #	Orifice ID	Nozzle Material
79377-44	1.4mm (.055 inch)	Standard Wear
79377-144	1.4mm (.055 inch)	Extended Wear
79377-45	1.8mm (.070 inch)	Standard Wear
79377-145	1.8mm (.070 inch)	Extended Wear
79377-46	1.0mm (.042 inch)	Standard Wear
79377-146	1.0mm (.042 inch)	Extended Wear
79377-47	.7mm (.028 inch)	Standard Wear
79377-147	.7mm (.028 inch)	Extended Wear
79377-48	1.2mm (.047 inch)	Standard Wear
79377-148	1.2mm (.047 inch)	Extended Wear

FLUID NOZZLE SELECTION TRANS-TECH. CHART		
Fluid Nozzle Part #	Orifice ID	Nozzle Material
79552-244	1.4mm (.055 inch)	Standard Wear
79552-344	1.4mm (.055 inch)	Extended Wear
79552-245	1.8mm (.070 inch)	Standard Wear
79552-345	1.8mm (.070 inch)	Extended Wear
79552-246	1.0mm (.042 inch)	Standard Wear
79552-346	1.0mm (.042 inch)	Extended Wear
79552-247	.7mm (.028 inch)	Standard Wear
79552-347	.7mm (.028 inch)	Extended Wear
79552-248	1.2mm (.047 inch)	Standard Wear
79552-348	1.2mm (.047 inch)	Extended Wear

AIR CAP / FLUID NOZZLE SELECTION CHART AIR SPRAY / TRANS-TECH. SPRAY				
Air Cap Part #	Fluid Nozzle Part #	Orifice ID	Separate Retaining Ring	Pressure Reducer
79374-65	79377-44	1.4mm (.055)	79379-00	74963-05
79374-65	79377-45	1.8mm (.070)	79379-00	74963-05
79374-98	79377-44	1.4mm (.055)	79379-00	74963-05
79374-98	79377-45	1.8mm (.070)	79379-00	74963-05
79374-122	79552-44	1.4mm (.055)	79379-00	74963-06
79374-122	79552-45	1.8mm (.070)	79379-00	74963-06

AIR CAP / FLUID NOZZLE PERFORMANCE CHART									
Fluid Nozzle Part #	Orifice ID (in/m)	Fluid Delivery* (ml/min)	Spray Type	Air Consumption** (SCFM/SLPM)	Air Pressure (psi/bar)	Air Cap	Pattern Size*** (inches)	Pressure Reducer	Applicators
79377-45	.070/1.8	300	Air Spray	18/510	22/1.5	79374-65	15±1/2	Black	Vector
79377-45	.070/1.8	300	Air Spray	18/510	37/2.6	79374-98	17±1/2	Black	
79522-245	.070/1.8	300	LVMP	8.3/234	30/2.1	79374-122	12±1/2	Green	

- * Material: Lacquer, 18 Sec. No. 4 Ford Cup @ 72°F. Results are material dependent.
- ** Air Flow @ Air Pressure noted in next column.
- *** Patterns at 8-inch target distance.

ROUND SPRAY PERFORMANCE CHART									
Fluid Nozzle Part #	Round Air Cap Part #	Retaining Ring Part #	Spray Type	Air Applicators (SCFM/SLPM)	Air Pressure (psi/bar)	Pattern Size Ø			
79959-00	79962-00	79379-00	Swivel / Round	7.1/ Horn Closed 202	25/1.7	Fan Open	Fan Closed	Pressure Reducer	Applicators
				8.1/ Horn Closed 230		2.0" / 50mm	3.5" / 89mm	Black	Vector

OPERATION

POWERING UP CONTROL UNIT

When the AC power is turned on, the unit will display the PC board applicator type number on the kV setpoint display and the software revision level in the μ A display for 2-3 seconds.

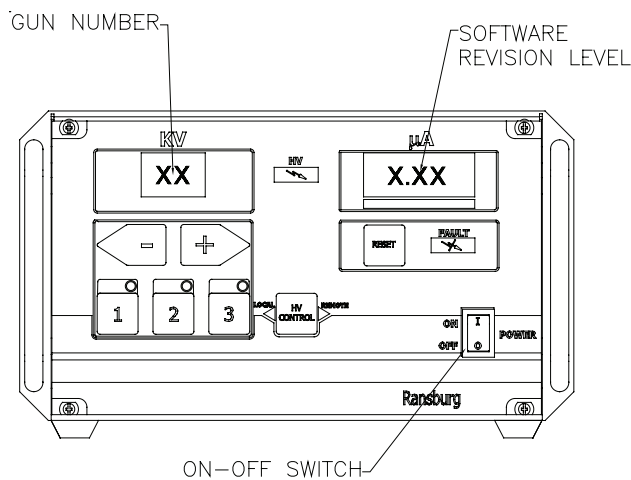

Figure 4: Control Unit Start-Up Display

START-UP DISPLAY	
Applicator Type	Description
1	85 kV Cascade
5	65 kV Cascade

CAUTION

► **DO NOT** connect a 65 kV applicator to a unit setup for 85 kV. Damage to 65 kV barrel assembly may occur.

SETPOINT VOLTAGE

The Vector spray applicator system has three voltage setpoints 1, 2, and 3. Each of these voltages can be individually adjusted between 20 and full kV using the + and - buttons on the front of the control unit. When the applicator trigger is off, the present setpoint can be changed either from the control unit or from the switch on the back of the applicator.

NOTE

► Setpoints cannot be adjusted below 20 kV.

Setting and Changing the Setpoint at the Control Unit

From the factory, Preset 1 is full minus 20 kV, Preset 2 is full kV minus 10, and Preset 3 is full kV. For 79500/79523 full kV is 85 kV. For 79501 full kV is 65 kV.

At the control unit with the applicator not triggered, press the 1, 2, or 3 button on the front panel of the control unit. (See Figure 5 for positions of the kV setpoint and adjust buttons.) The only place to adjust the kV of each setpoint is at the control unit.

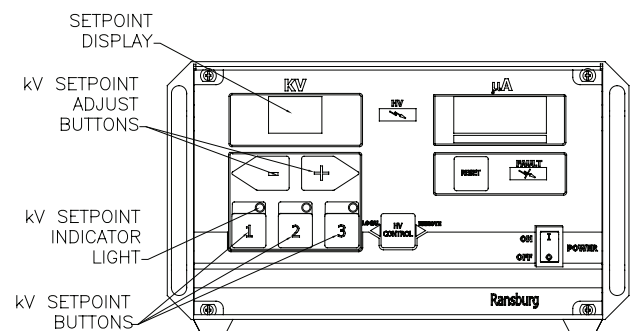

Figure 5: Front View of Control Unit

When a kV setpoint button is pressed, the light above the button will light and the kV display will show the present voltage for that setpoint. This indicates the unit is set to spray at that setpoint. To adjust the kV for the present setpoint, press the + or - setpoint adjust buttons.

When the + or - setpoint adjust buttons are held in longer than 1 second, the kV display will begin incrementing or decrementing in units of 5 instead of 1.

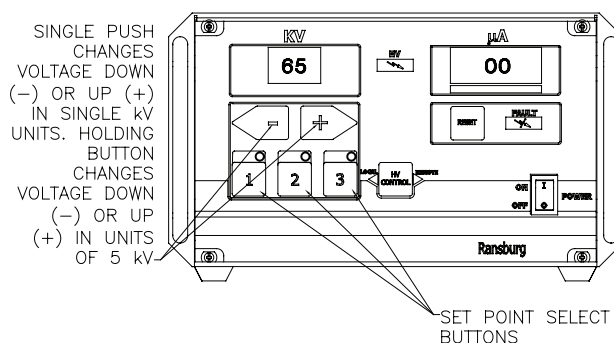

Figure 6: Changing Setpoint

Changing the Setpoint at the Applicator

To change the setpoint at the applicator, the applicator must NOT be triggered. By pushing the kV button on the rear cover of the applicator, the setpoint will change. If there are 2 green lights lit, setpoint 1 is active. If 2 green lights and 2 yellow lights are lit, setpoint 2 is active. If all lights are lit (2 green lights, 2 yellow lights, and 2 red lights) setpoint 3 is active.

kV to the applicator can be turned off by pressing the applicator kV button in for 2-3 seconds. This can be done whether the applicator is triggered or not and is useful if the kV needs to be turned off for spraying into recessed areas. When the kV is disabled in this manner, the kV meter will read zero, OFF will be displayed in the microamp meter and all kV setpoint indicator lights will be disabled. Pressing the kV button in for another 2-3 seconds turns the kV to the applicator back on.

⚠ WARNING

➤ **DO NOT** turn the applicator off using the applicator button in place of interlocking with a solvent supply for flushing. The applicator must be interlocked with solvent supply such that when the solvent is on to flush the applicator, there is no kV at the applicator.

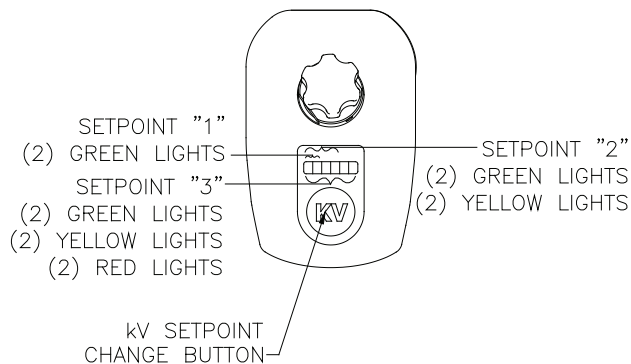

Figure 7: View of Rear Cover

LOCKOUTS

There are lockouts that may be done at the PC board (see Figure 8). These lockouts may be used individually or in combination as required. If the jumpers are disconnected, the original functions are re-enabled. After changing any jumpers, the AC power must be cycled for the new setting to take affect.

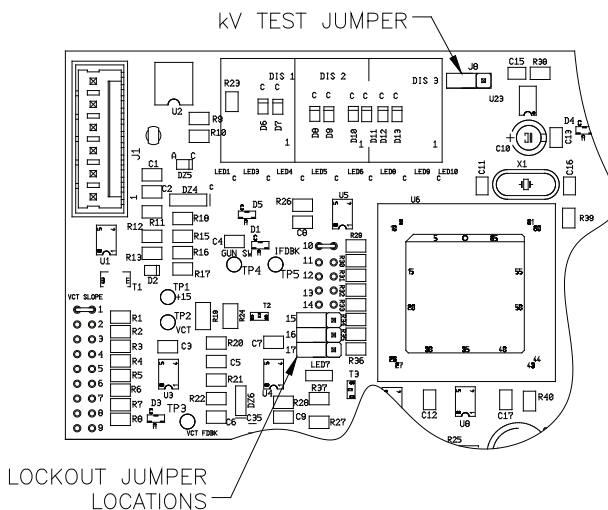

Figure 8: Lockout Jumper Location

Front Panel Lockout

This feature locks out any changes to the kV setting from the front panel of the control unit.

1. Set the kV to the desired value using the front panel buttons. This must be set prior to installing the jumper.
2. Turn AC power off and access the interior of the control unit.
3. Place the jumper across the two (2) pins at location 16 on the main PC board (see Figure 9).
4. Close the control unit and turn AC power back on. Pressing the front panel +, -, or setpoint buttons will now have no effect on the kV setting.

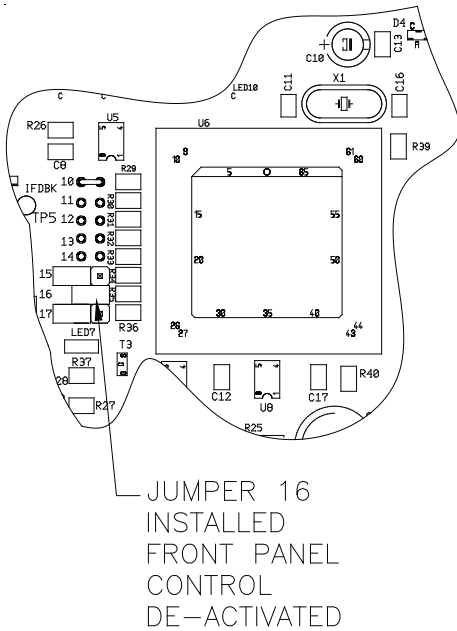

Figure 9: Jumper Location - Front Panel Lockout

Applicator Switch Lockout

The applicator switch may be de-activated for applications that require the operator to not be able to change settings or turn the applicator off at the applicator.

1. Turn AC power off and access the interior of the control unit.

2. Place the jumper across the two (2) pins at location 15 on the main PC board (see Figure 10).

3. Close the control unit and turn AC power back on. It will now be no longer possible to change setpoints or turn kV off at the applicator.

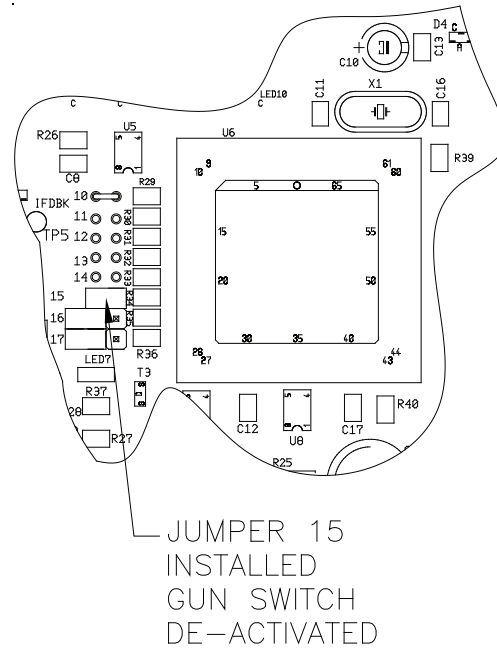

Figure 10: Jumper Location - Applicator Switch Lockout

Overload Activation

The overload circuit may be activated for applications that require notification of high applicator output currents. The overload value is set in the software and is maximum microamp rating minus 10 microamps.

1. Turn AC power off and access the interior of the control unit.

2. Place the jumper across the two (2) pins at location 17 on the main PC board (see Figure 11).

3. Close the control unit and turn the AC power back on. An overload fault will now occur if the microamp display comes within 10 microamps of the maximum current.

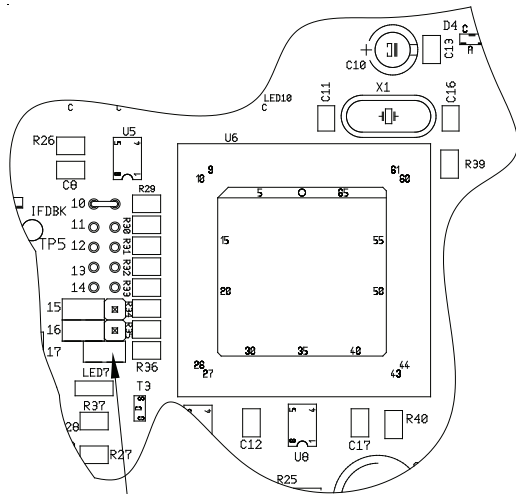

JUMPER 17
INSTALLED
OVERLOAD
ACTIVATED

Figure 11: Jumper Location - Overload Activation

KV TEST JUMPER

To assist in testing and troubleshooting, a jumper (J8) has been added to the main PC board. By covering (shorting) both terminals of this jumper, the high voltage to the spray applicator can be activated. Thus, for testing and troubleshooting, high voltage output can be obtained without the need to trigger air through the spray applicator. After testing, the jumper must be repositioned so that it covers only one terminal (open) or the high voltage will stay on all the time. (See Figure 8 for location of test jumper J8.)

	CAUTION
<p>➤ If jumper J8 is left covering (shorting) both terminals, high voltage will be on whenever AC power is turned on.</p>	

BASIC OPERATION

Triggering

High voltage is actuated by pulling the trigger to start the flow of atomizing and fan control air through the applicator. When the applicator is triggered, an air flow switch is activated, the kV setpoint is displayed on the kV display, the actual current draw on the μ A display and the high voltage light illuminates. Under the μ A display is a bar graph meter that illuminates according to the actual current draw.

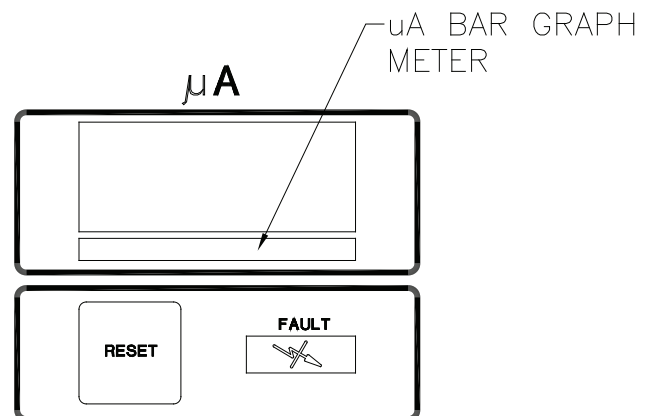

Figure 12: μ A Bar Graph Display

The green and yellow regions of the bar graph meter indicate output current is in the optimum range for maximum transfer efficiency. The red region of the bar graph indicates high output current causing decreased transfer efficiency.

The display at the rear of the applicator also doubles as a microamp bar graph meter when high voltage is on (see Figure 13). Its function is similar to that of the control unit bar graph display.

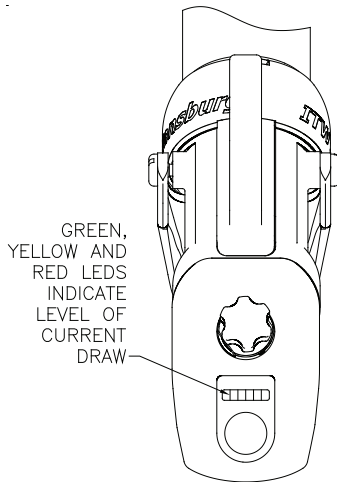

Figure 13: View of Applicator LED Display

Measuring "High Voltage On" Time

The 9060 Power Supply records the amount of time the high voltage is triggered on up to 99,999 hours. These units are displayed in the kV and μA displays of the unit. There are two registers that retain this information, one that may be reset, the other that is permanently retained in memory. The number of hours the unit's high voltage has been on may be displayed by depressing at the same time the preset 1 and reset buttons. The display will show hours of use for 3 seconds. This is the re-settable register.

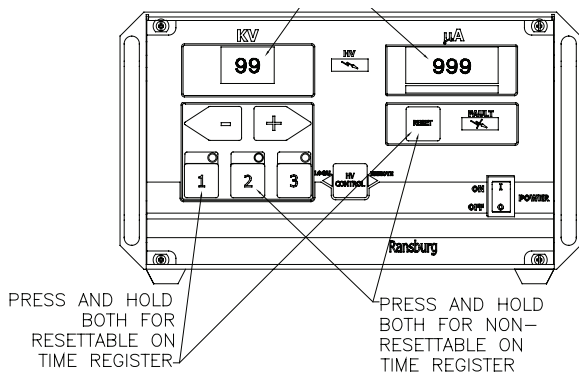

Figure 14: Display In "High Voltage On" Time

To reset this register, press the reset button while the hours are displayed. Pressing the preset 2 and reset buttons at the same time will show the number of hours on the non-re-settable register.

Local/Remote

The Vector product line is designed currently for applicators only. The local/remote high voltage control switch should be set to local for all Vector applicator applications.

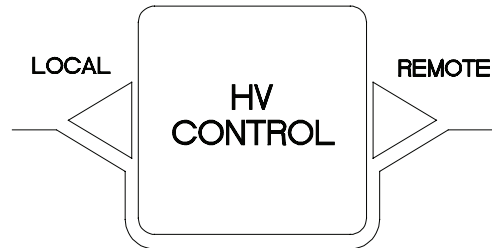

Figure 15: High Voltage Control Switch

! CAUTION
<p>► The unit will not function if it is in remote mode without external inputs.</p>

FAULT DESCRIPTIONS

For in depth troubleshooting information on the 9060, refer to CP-XX-XX. When a fault occurs, the Fault Indicator on the front of the control unit will light, a fault code will be displayed on the microamp meter and the 6 LED's at the rear of the applicator will flash. Faults can be reset by pressing the Reset button on the front of the control unit or by pressing and holding the kV switch at the rear of the applicator for 2-3 seconds.

MAINTENANCE

SUITABLE SOLVENTS FOR CLEANING VECTOR R90/70 APPLICATORS

When cleaning the applicator, a suitable solvent for cleaning depends on the part(s) of the applicator to be cleaned and the material that needs to be removed. Ransburg recommends that all exterior cleaning be done with non-polar solvents to prevent a conductive residue on critical components. We also understand that some of these solvents do not always meet the cleaning needs of some materials. If conductive polar solvents are used to clean the applicator components, all residue must be removed using a non-conductive non-polar solvent (i.e. high flash Naphtha). If there are any questions as to what solvents are best for cleaning, contact your local Ransburg distributor and/or your paint supplier.

The Vector applicator, air hoses, fluid hose, and high voltage cable assemblies should not be submerged or soaked in solvent. However, the outer surfaces of these items can be wiped with a suitable cleaning solvent. The items that cannot be soaked are noted throughout this manual. All electrical components **cannot** be cleaned or soaked in any solvents.

WARNING

- The user **MUST** read and be familiar with the safety instructions in this manual.
- If compressed air is used in cleaning, **REMEMBER** that high pressure air can be dangerous and should **NEVER** be used against the body. It can blind, deafen, and may even penetrate the skin. If used for cleaning equipment, the user should wear safety glasses.
- **ALWAYS** turn the control unit's power off prior to cleaning and servicing the equipment.
- Be **SURE** the power is **OFF** and the system is grounded before using solvent to clean **ANY** equipment.
- **DO NOT** operate a faulty applicator!
- When using cleaning solvent, standard health and safety precautions should apply.
- Any solvent used to clean the fluid passages must be discharged into a grounded container. Use of ungrounded or plastic containers may cause fire or explosion.
- Cleaning of the exterior surface of the applicator should be done with non-polar solvents. If cleaning requires the use of polar solvents, the applicator should be wiped down with non-polar solvent prior to going back into use. Using polar solvents will leave a semi-conductive film on the surface of the applicator that will effect efficiency of the applicator and cause damage to the components.

ROUTINE SCHEDULE

Follow these maintenance steps to extend the life of the applicator and ensure efficient operation:

Several Times Daily

- Turn the control unit power to OFF!
- Inspect the air cap for paint accumulation. Clean as frequently as necessary with a soft bristled brush and a suitable solvent.

 **CAUTION**

➤ **NEVER** remove the fluid nozzle assembly while paint is in the applicator or paint may enter into the air passages. Clogged or restricted air passages will cause poor atomization and/or electrical shorting. Air passages that are clogged with conductive material can lead to excessive current output levels and consequent low operating voltage or long-term electrical damage. Before undertaking any atomizer maintenance procedure, see "Applicator Assembly Cleaning Procedure" in the "Maintenance" section.

The applicator barrel **MUST** be tilted front down to remove the fluid nozzle. Failure to do so may allow paint to enter the air passages, thereby reducing airflow and damaging the applicator barrel/cascade. Applicators may be flushed in lieu of tilting. However, they must be either flushed or tilted down during nozzle removal!

- Clean all insulating surfaces in the system. Remove paint accumulation from the exterior of the applicator and low voltage cable with a solvent dampened cloth.

 **CAUTION**

➤ **NEVER** soak or submerge the electrical components of the applicator, i.e., barrel, hook, or cable. Damage and failure may occur.

Daily (or at start of each shift)

- Verify that ALL solvent safety containers are grounded!
- Check within 20 feet of the point of operation (of the applicator) and remove or ground ALL loose or ungrounded objects.
- Inspect work holders for accumulated coating materials (and remove such accumulations).
- Check that atomizer assembly is clean and undamaged.

NOTE

➤ Standard electrode is "snap back" spray wire electrode.

- Straighten the applicator electrode if necessary.
- Clean the fluid filter, if used.
- Turn the control unit power ON.
- Run a current/voltage output test.

Electrical Current Output Test

1. Turn the paint and/or solvent supply OFF.

 **WARNING**

➤ Paint and/or solvent supply must be turned off during this test - risk of fire or explosion.

2. Trigger the applicator (high voltage ON).
3. Slowly approach the applicator electrode to any grounded object and make contact.
4. Monitor the current output reading on the control unit microamp meter as the applicator approaches ground:

Upon ground contact, the microamp meter should display 100 μA (for R90) or 90 μA (for R70) and the green, yellow, and red LED's of the bar graph meter will all be illuminated.

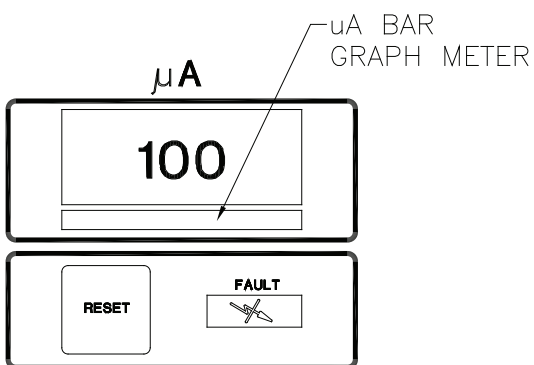

Figure 16: Control Unit Meter Current Output Test Reading

If the reading is outside of the acceptable range (95-100 μA for R90; 85-90 μA for R70), DO NOT use the applicator until the problem has been corrected (see "Troubleshooting Guide" in the "Maintenance" section.)

5. Release the trigger (high voltage OFF) and turn the control unit power OFF.

Shutdown (or at end of each shift)

1. Turn the power supply power OFF.
2. Turn the paint supply OFF.
3. Turn the atomizing and fan air OFF.
4. Wipe the applicator, cable, and hoses with a rag and a suitable cleaning solvent.

NOTE

► If production downtime is to be short, the fluid lines may not require flushing, depending on the coating material being used. If the solids in the material settle slowly, the lines will not need to be flushed as soon after shutdown as with fast settling solids. The paint being used and the length of downtime will determine the need for flushing. Metallic paint and primer will require flushing sooner than other types of coating materials.



CAUTION

► If the coating material is fast settling and the fluid lines are not flushed soon enough, the internal passages may become clogged. This can lead to excessive downtime for repair.

5. Flush the lines and allow the solvent to remain in the lines unpressured (see "Flushing Procedure" in the "Maintenance" section).

Weekly

- Check the entire system for damage, leaks, and paint accumulation.
- Clean the atomizer assembly.

APPLICATOR ASSEMBLY CLEANING PROCEDURE

Routine Cleaning Equipment Needed

- An appropriate solvent
- A solvent safety container (grounded)
- A small soft-bristled brush
- The Ransburg special multi-purpose wrench (19749-00)

! CAUTION

- To avoid damage to the fluid nozzle or needle/electrode, the paint pressure **MUST** be released by triggering the applicator prior to removing the tip.
- The applicator barrel **MUST** be tilted front down to remove the fluid nozzle. Failure to do so may allow paint to enter the air passages, thereby reducing airflow and damaging the applicator barrel/cascade. Applicators may be flushed in lieu of tilting. However, they must be either flushed or tilted down during nozzle removal!
- The control unit power **MUST** be off when removing the nozzles and/or during any applicator maintenance.

! CAUTION

- When installing or removing the fluid nozzle, the applicator **MUST** be triggered. Failure to do so may cause damage to the electrode or fluid nozzle. Such damage can result in fluid leaks around the sealing area of these components.
- Using any tool other than the Ransburg multi-purpose wrench (19749-00) to remove or install the fluid nozzle may cause damage.

For efficient electrostatic operation, keep the applicator's exterior and low voltage cable free of paint accumulation. This prevents the loss of voltage to ground with a resultant reduction in transfer efficiency. Paint accumulation in and around the air cap nozzles will reduce atomization quality. Clean the air cap using clean solvent and a soft bristle brush as often as needed to ensure good atomization.

! WARNING

- **NEVER** wrap the applicator, associated valves and tubing, and supporting hardware in plastic to keep it clean. A surface charge may build up on the plastic surface and discharge to the nearest grounded object. Efficiency of the applicator will also be reduced and damage or failure of the applicator components may occur. **WRAPPING THE APPLICATOR IN PLASTIC WILL VOID WARRANTY.** Only approved applicator covers should be used.

Proceed as follows:

1. Turn OFF the control unit power.
2. Release the trigger.
3. Turn the paint flow OFF.
4. See "Applicator Repair - Disassembly Procedures" in the "Maintenance" section.

! WARNING

- Any broken or damaged components should be replaced. Any damage to the applicator may result in **UNSAFE** operating conditions.

5. Clean the applicator and associated parts with a soft brush and suitable solvent.

! CAUTION

- Metal tools and wire brushes must **NEVER** be used. **NEVER** use a cleaning tool that is harder than the plastic parts. If a deposit cannot be removed with the solvent and a rag or the soft brush, soak **ONLY** the part in the solvent until the deposit can be removed! **NEVER** soak the applicator body or barrel!

FLUSHING PROCEDURES

1. Turn OFF the control unit power.

WARNING

- ▶ Whenever solvent is flushed through the applicator the control unit power must be off.

2. Turn the paint supply OFF.
3. Turn the atomizing air supply OFF.
4. Tilt the applicator down and trigger until it is clear of paint.
5. Connect the solvent supply.
6. Run solvent through the system until it runs clear.

WARNING

- ▶ Any solvent used to clean the fluid passages must be discharged into a grounded container. Use of ungrounded or plastic containers may cause fire or explosion.

7. Disconnect the solvent supply.
8. Trigger the applicator until it is clear of solvent. After the preceding steps are complete, the applicator is ready for color change, storage, or maintenance.

CAUTION

- ▶ **DO NOT** allow the fluid lines to stand empty without flushing first! This will cause dried paint flaking and clogging of the fluid lines, applicator passages, and/or nozzles.

APPLICATOR REPAIR

All repairs should be made on a clean, flat surface. If a vise is used to hold parts during service or repair, **DO NOT** clamp onto plastic parts and always pad the vise jaws!

The following parts should be thoroughly packed with dielectric grease (LSCH0009-00) leaving **NO** air space or voids when assembling:

- All O-Rings (PTFE o-rings do not need lubrication)
- Needle Shaft Assembly
- Packing Tube
- Cartridge Assembly, Non-Adjustable
- Air Valve Rod Assembly

Apply sealant (7969-10) to the external threads of the following parts when assembling:

- Nut Air Valve Retaining (78635-00)
- Cap, Air Valve (79317-00)

Equipment Required

- Special Multi-Purpose Wrench (19749-00)
- 3/32" Allen Wrench for Set Screws
- Screwdriver (blade)
- Dielectric Grease (LSCH0009-00)
- Sealant, Medium Strength (7969-10)
- Plastic or Wood Dowel Rod, 5/16" Diameter

TO REMOVE THE APPLICATOR FROM THE WORK SITE

CAUTION

- **ALWAYS** remove the applicator from the work site for service or repair!
- **DO NOT** use any silicone lubricants in order to avoid paint defects.

WARNING

- Ensure the control unit power is **OFF** prior to any maintenance.

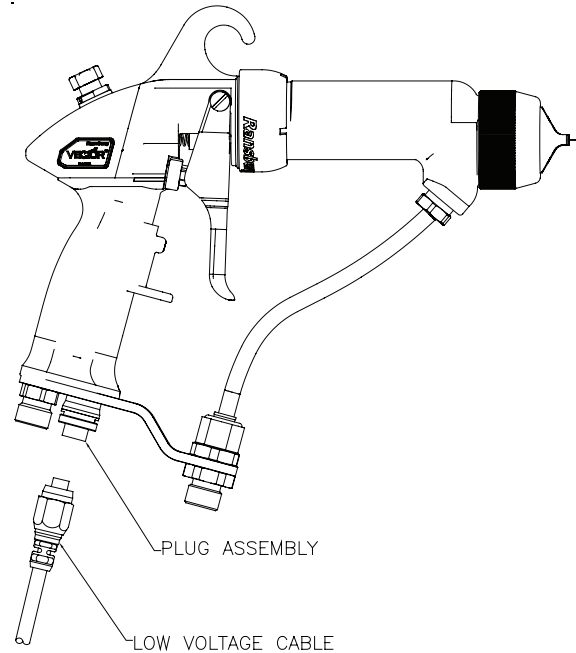

Figure 17: Removing Cascade Applicator

Solventborne Applicators

1. Flush the applicator. (Refer to "Flushing Procedures" in the "Maintenance" section.)
2. With a wrench, loosen and unscrew the fluid hose nut. Remove the fluid hose assembly.
3. With a wrench, lock the air fitting in place and loosen the air hose nut using a second wrench. Completely unscrew the nut and remove the air hose assembly.
4. Using a 16mm (5/8") open-end wrench, loosen the low voltage cable from the cable plug. Pull the cable straight out of the plug assembly.
5. Remove the applicator from the work site.

AIR CAP

Removal

1. While holding the barrel with one hand, loosen the retaining nut using the other hand.
2. Unscrew the retaining nut completely and remove the air cap.

Cleaning and Inspection

1. Use a suitable solvent to clean the air cap. (Refer to "Suitable Solvents for Cleaning Vector R90/70 Applicators" in the "Maintenance" section.)
2. Examine the air cap for damage to the air horns, face, and any air passages. If any of these areas are damaged or worn, the air cap should be replaced.

Reinstall

1. Check the fluid nozzle to ensure that it is tightly screwed into the barrel.
2. Place the air cap over the electrode wire of the needle/electrode and set it onto the fluid nozzle.

- Place the retaining nut over the air cap and begin screwing it onto the barrel.
- Before securing the retainer nut to the barrel, position the air cap for the desired spray pattern position.

FLUID NOZZLE (Refer to Figure 18)

Removal

- Remove the air cap from the applicator (refer to "Air Cap - Removal" in the "Maintenance" section).
- Tilt the applicator forward and pull the trigger to make sure that all fluid in the applicator is drained out.

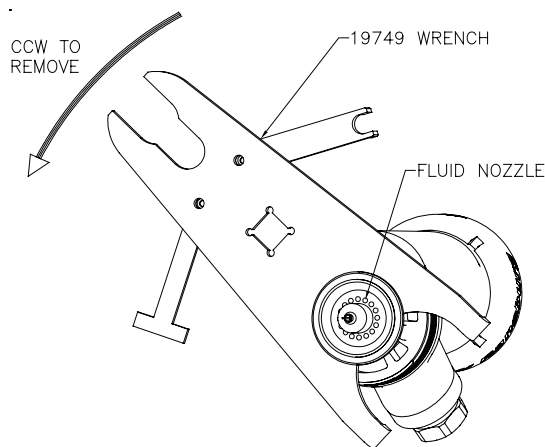

Figure 18: Removal of Fluid Nozzle

CAUTION

➤ The applicator barrel **MUST** be tilted front down to remove the fluid nozzle. Failure to do so may allow paint to enter the air passages, thereby reducing airflow and damaging the applicator barrel. Applicators may be flushed in lieu of tilting. However, they **MUST** be either flushed or tilted during nozzle removal!

- While holding the applicator assembly with the trigger pulled back, remove the fluid nozzle with the open-end of the special multi-purpose wrench.

NOTE

- To keep the needle/electrode from unscrewing from the needle shaft, the applicator's trigger should be actuated to pull the needle/electrode away from the fluid nozzle.

Cleaning and Inspection

- Use a suitable solvent to clean the fluid nozzle
- Examine the fluid nozzle for damage to the air passages and the fluid nozzle tip. Also, examine the needle seat for damage or wear. If any damaged or any worn areas are found, the fluid nozzle must be replaced.

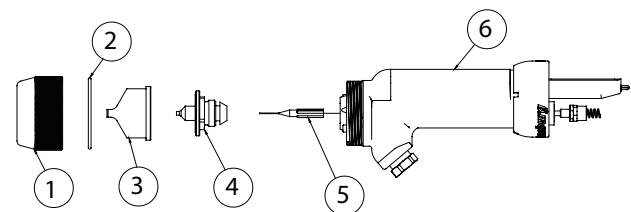

- 1 - Retaining Ring
- 2 - O-Ring, PTFE Encapsulated
- 3 - Air Cap
- 4 - Fluid Nozzle
- 5 - Electrode Assembly
- 6 - Barrel Assembly

Figure 19: Air Cap, Fluid Nozzle, and Nut

NOTE

- If the fluid nozzle is replaced, there is a good chance that the needle/electrode assembly will need to be replaced also. A worn needle/electrode assembly may not always seat well in a new fluid nozzle.

Reinstall

1. Check the needle/electrode tightness on the needle shaft. If it is loose, tighten it (refer to "Needle/Electrode" in the "Maintenance" section).
2. With the applicator trigger actuated, place the fluid nozzle over the needle/electrode and screw it into the barrel by hand.
3. Tighten it using the special multi-purpose wrench with 3/8" square. Torque to 40-45 lbs - in (4.5-5.1 Nm). An alternate method (if no torque wrench is available) is to hand tighten, then tighten an additional 1/16 to 1/8 turn in the clockwise direction.

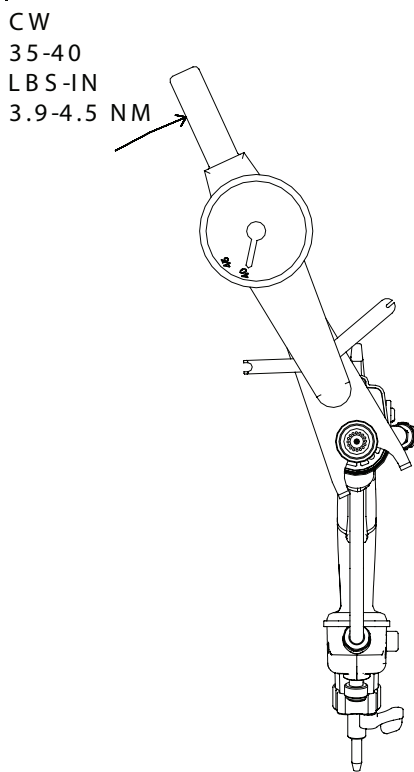

Figure 20: Reinstalling Fluid Nozzle

NOTE

- **DO NOT** over-tighten the fluid nozzle into the barrel. Doing so could damage or break the fluid nozzle or damage the thread of the barrel.

4. Install the air cap and retaining ring onto the applicator (refer to "Air Cap - Reinstall" in the "Maintenance" section).

NEEDLE / ELECTRODE

Removal

1. Remove the air cap and fluid nozzle from the applicator assembly.
2. Secure the needle shaft at the rear of the barrel and unscrew the needle/electrode from the needle shaft.

Cleaning and Inspection

1. Use a suitable solvent to clean the needle/electrode.
2. Examine the needle/electrode for damage or wear. Pay special attention to the area where the wire electrode extends from the main body. This is a sealing surface that seats inside the fluid nozzle. If there are signs of wear in this area, both the needle/electrode and fluid nozzle must be replaced.
3. An electrical check of the needle/electrode must be done prior to reinstalling it into the applicator assembly (refer to "Needle/Electrode Resistance Testing" in the "Maintenance" section).

Reinstall

1. Secure the needle shaft at the rear of the barrel and screw the needle/electrode into place by hand.
2. Reinstall the fluid nozzle and air cap onto the barrel.

NEEDLE / ELECTRODE RESISTANCE TESTING

The electrical resistance of the needle/electrode should be tested periodically (typically on a weekly basis) or any time it is removed from the applicator.

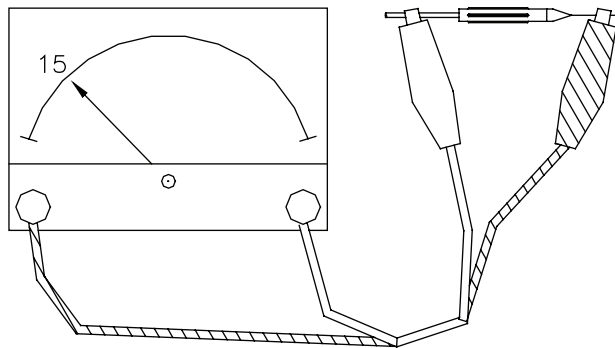

Figure 21: Testing Resistive Electrode

1. Install the needle/electrode onto the front end of an available needle shaft. Be sure that the needle/electrode is completely seated for proper contact between the metal shaft and the threaded insert of the needle/electrode.
2. Using a VOM meter that will read 15 megohms accurately, connect the first meter lead to the metal needle shaft and the second lead to the needle/electrode wire. The needle/electrode resistance should be 14.5 to 19 megohms (nominal 15 megohms at 9 volts or 12 to 17 megohms at 1000 volts). Needle/electrodes outside these ranges must be replaced.

BARREL ASSEMBLY

Removal

1. While holding the barrel with one hand, loosen the air cap retaining nut using the other hand.
2. Unscrew the retaining nut completely and remove the air cap.

3. Using a flat head screwdriver, loosen the two (2) shoulder screws that retain the trigger to the applicator handle.

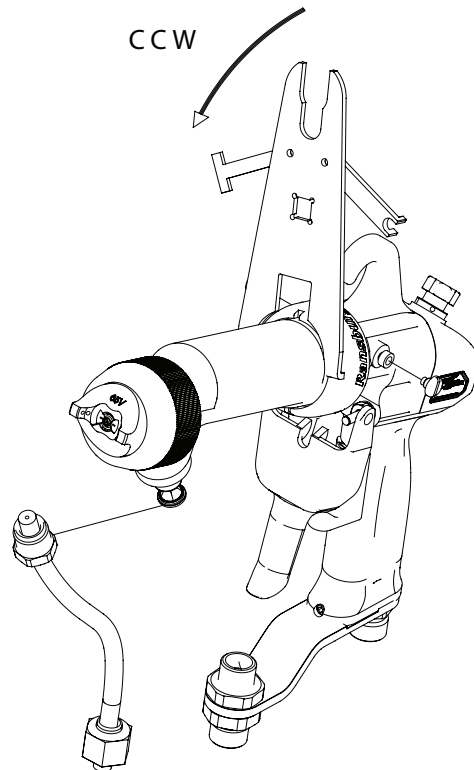

Figure 22: Barrel Assembly Removal

4. Remove trigger from the applicator handle.
5. Using an adjustable wrench, unscrew the fluid tube connector from the barrel and slide it down the fluid tube. The fluid tube must be removed prior to removing the barrel to prevent damage to the cascade.
6. Use the special multi-purpose wrench to loosen the retaining nut that secures the barrel to the applicator handle. After unscrewing the nut, slide it forward onto the barrel.
7. Hold the applicator handle and fluid tube so the barrel points downward. With the other hand, pull the barrel forward to separate it from the handle. Once the barrel has cleared the handle, remove the spring from the spring retainer and set it aside.

8. There is no need to remove the retaining ring or nut from the barrel unless they are damaged. If they are to be replaced, lift one end of retaining ring over the captive ridge and spiral it off the end of the barrel. Then the retaining nut can be removed.

 CAUTION
<p>➤ Use care in removing the retaining ring. If it is spread too much it could break.</p>

DISASSEMBLY/ REASSEMBLY OF BARREL WITH THE 2K FLUID NEEDLE PACKINGS

Disassembly

1. Remove the trigger adjustment nut and spring retainer from the needle shaft using two 3/8" open-end wrenches.
2. Position the barrel so the front is facing down. Using the small spanner tool on the special multi-purpose wrench, unscrew the packing nut from the rear of the barrel by turning it counter-clockwise.

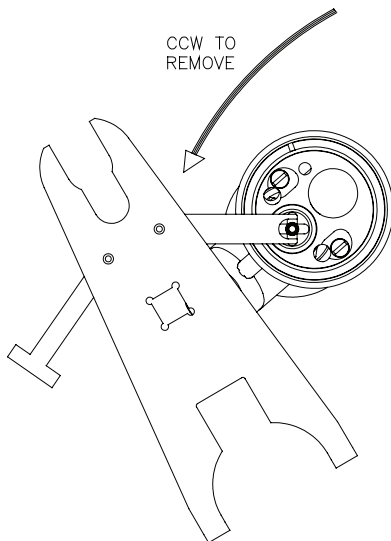

Figure 23: Removal of Needle Shaft

3. Hold the barrel in one hand and with a firm pull, remove the needle shaft assembly from the packing chamber of the barrel. The trigger adjustment nut can be reinstalled for additional grip. If the needle shaft will not pull out of the barrel, use the following procedure.

- a. Remove the needle/electrode from the needle shaft.
- b. Pull the needle shaft from the rear of the barrel.
- c. Place the barrel on a work bench. Holding the barrel in one hand, with the front pointing upward, push a 5/16-inch diameter wooden or plastic dowel rod, down through the center bore of the barrel. This should push all of the packing chamber parts out the rear of the barrel.

NOTE

- | |
|--|
| <p>➤ The six (6) spring washers will come off the needle shaft assembly at this point.</p> |
|--|

 CAUTION

- | |
|---|
| <p>➤ During this operation, be CAREFUL that the interior surface of packing chamber is NOT damaged (marred or scratched)! This chamber is a seal area and the barrel/cascade assembly will have to be replaced if it is damaged.</p> <p>➤ DO NOT lose any of the spring washers! The applicator MUST have all six, correctly positioned, in order to function properly!</p> |
|---|

4. Remove the trigger adjustment nut if it was required when pulling the needle shaft from the barrel packing chamber. Then remove the packing nut, spacer, rear seal retainer sub-assembly, and packing tube from the rear of the needle shaft. The spring loaded u-cup and o-ring can now be removed from the rear seal retainer.

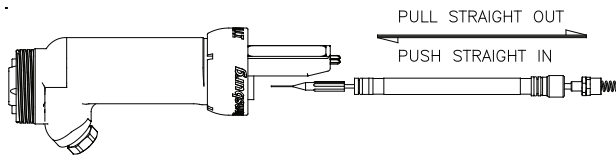

Figure 24: Needle Shaft Insert/Removal

NOTE

➤ If the spacer and seal retainer do not separate easily, wedge a knife blade between them and pry them apart.

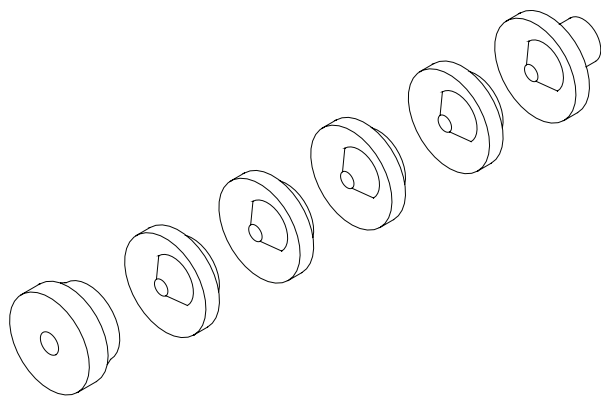

Figure 25: Chevron Seal Assembly

5. Unscrew needle/electrode from shaft and slide the male chevron adapter, the chevron seals and female chevron adapter off the shaft (see Figure 31).
6. Remove retaining ring and air cap from barrel.
7. Loosen the fluid nozzle using the special multi-purpose wrench and unscrew it by hand to remove.

Cleaning and Inspection

1. Clean the packing chamber of the barrel with a suitable solvent and a soft bristle bottle brush. **DO NOT submerge or soak the barrel in solvent.** If the chamber has dry paint in it and cannot be cleaned out, the barrel **MUST BE REPLACED.**

CAUTION

➤ Soaking or submerging the barrel could allow solvents into the high voltage section of the barrel, leading to applicator failure and/or possible dangerous conditions that could result in property damage and personnel injury.

2. Examine the plastic section of the needle shaft and the packing tube for signs of carbon tracking. Also, inspect the air passages and packing chamber of the barrel for signs of scratches, additional carbon tracking, or dried paint. Shine a small flashlight into the front of the barrel to highlight any damage in these areas.

3. From time to time it is desirable to test the electrical integrity of the 70430-01 resistive electrode (see "Needle/Electrode Resistance Testing" in the "Maintenance" section).

Reassembly

(Refer to Figures 26, 27, 28, and 29)

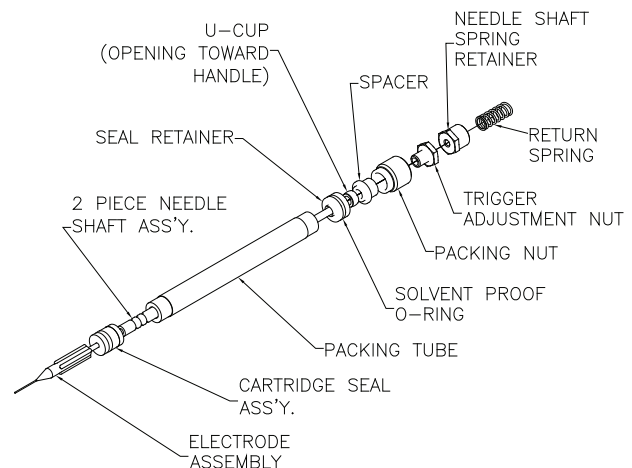

Figure 26: Needle Shaft Assembly (2k Packings)

! CAUTION

- To avoid damage to the chevron seals, they **MUST** be installed from the rear of the barrel.

! CAUTION

- **FAILURE** to coat the needle shaft assembly **MAY CAUSE** lower electrical output of the applicator.

1. Place conductive female chevron adapter onto the front of shaft with the concave side toward the front.
2. Screw the four (4) chevron seals onto shaft, concave sides forward.

5. Fill the inner diameter of the packing tube with dielectric grease.
6. Insert the needle shaft, rear section first, into the packing tube. Rotate the needle shaft while moving back and forth inside the packing tube until fully inserted.

! CAUTION

- **DO NOT** push the chevron seals straight onto the shaft. The shaft threads may damage the chevron bore and cause the applicator to leak fluid.
- Inspect needle/electrode shaft sealing surface for wear. If it is rough or uneven, replace it.

7. With your finger, wipe the excess grease from both ends of the packing tube. Using the excess grease, apply a thin film to the outer surface of the packing tube and to the external o-ring on the cartridge seal.

NOTE

- Be generous with the dielectric grease when applying it to the packing tube and needle shaft. This helps to remove air voids from this chamber. **DO NOT** apply so much grease that it creates an air lock during assembly of the applicator.

3. Place male nonconductive chevron adapter onto shaft with the convex end rearward.

NOTE

- The chevron adapters and chevron seals should seat together to form an unbroken seal.

8. Apply a light film of dielectric grease to the seal retainer o-ring and install it into the external groove.

4. Screw needle/electrode onto shaft and hand tighten.

9. Insert the spring loaded u-cup seal into the seal retainer (with the concave side facing outward). Use the short end of the spacer to seat the seal.

NOTE

- Apply a light coating of dielectric grease to the chevron seals and needle shaft.

10. While holding the rear seal retainer sub-assembly and spacer together, place these components (with the spacer rearward) onto the rear of the needle shaft and slide them over the sealing area.

11. Place the six (6) spring washers onto shaft with the first, third, and fifth ones concave (cupped) side forward. The second, fourth, and sixth ones should be cupped side rearward (see Figure 33).

! WARNING

➤ All six (6) spring washers **MUST** be replaced alternately as shown in Figure 33, or the applicator will malfunction.

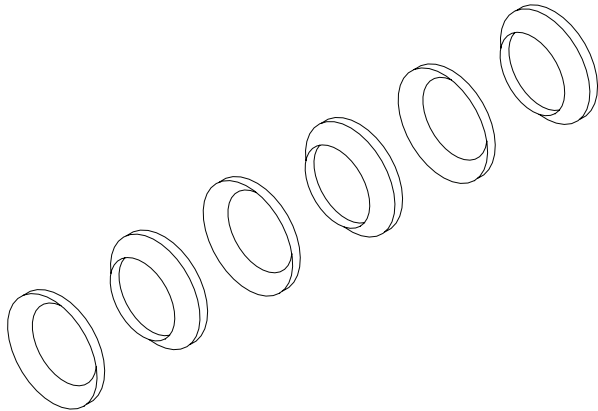

Figure 27: Spring Washer Assembly Sequence

12. Place the packing nut (large bore first) on the rear needle shaft section.

13. Screw the trigger adjustment nut onto the rear needle shaft section with the hexagon rearward and the spring retainer with the hexagon forward. Do not lock the hexagon nuts in place.

14. Install the needle shaft sub-assembly into the packing chamber from the rear of the barrel with the needle/electrode forward.

15. Push the needle shaft sub-assembly forward until the packing nut will engage its mating thread in the barrel and screw it into place by hand, approximately 3 turns.

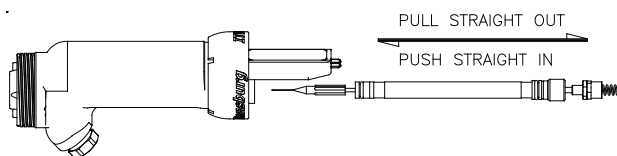

Figure 28: Needle Shaft Assembly Into Barrel

16. Pull the needle shaft rearward as far as it will go.

17. Install the fluid nozzle, air cap, and retaining nut (refer to "Air Cap" and "Fluid Nozzle" in the "Maintenance" section).

18. Tighten the packing nut using the spanner tool on the special multi-purpose wrench until a firm resistance is felt on the needle shaft while reciprocating it by hand.

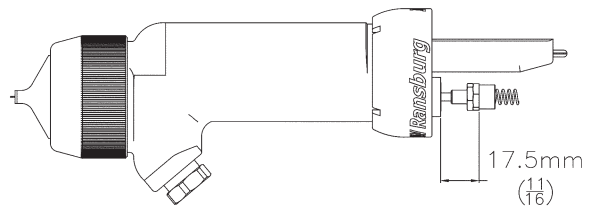

Figure 29: Trigger Adjustment Nut Dimensions

19. Push the needle shaft forward until the needle/electrode seats into the fluid nozzle.

20. Adjust the trigger adjustment nut as far forward on the needle shaft as possible.

21. Adjust the needle shaft spring retainer until the rear of the hexagon is 11/16-inch from the rear surface of the barrel packing chamber (refer to Figure 29).

22. Hold the spring retainer in place and screw the front trigger adjustment nut rearward until contact is made. Use two 3/8" open-end wrenches to tighten and lock the adjustment nuts in place on the needle shaft.

! CAUTION

➤ **DO NOT** overtighten the hexagon adjustment nuts or damage may occur to the plastic threads or the needle shaft may break. Finger tight is typically sufficient. (Maximum torque of 18-24 in•oz).

Attaching Barrel to Handle

1. If the barrel retaining nut has been removed, it will have to be reinstalled before the barrel can be attached to the handle.
2. Place the retaining nut over the rear of the barrel and slide it as far forward as possible.
3. Spread the retaining ring and place it onto the barrel. Starting at one end, lift the retaining ring over the captive ridge and spiral into place.
4. Place the large hole of the gasket over the needle shaft and onto the base of the barrel packing chamber.
5. While holding the barrel with the air nozzle pointing downward, install the needle shaft spring into the spring retainer. Align the rear end of the barrel assembly with the matting area of the handle assembly, and the needle shaft spring with the spring recess in the handle. Slide the barrel into the handle cavity until it is seated against the gasket. Ensure the needle shaft spring seats properly into the handle recess.
6. While holding the barrel in place, screw the retaining nut onto the handle by hand and then tighten using the special multi-purpose wrench.

NOTE

➤ Torque the retaining ring to 8-10 lbs•ft or after hand tightening, torque an additional 1/6 to 1/8 turn using the special multi-purpose wrench.

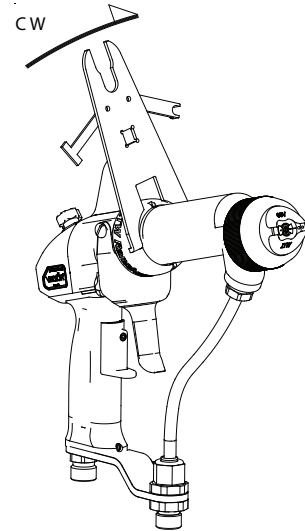

Figure 30: Barrel to Handle Assembly

7. Check the spacing between the back of the spring retainer and the handle. It should be about 1/8-inch. If not, check for one or more of the following:
 - Gasket has been left out
 - Loose retaining nut
 - Loose fluid nozzle
 - Improper adjustment of the trigger adjustment nut and spring retainer
8. Secure the trigger with the two (2) shoulder screws.

NOTE

➤ The needle shaft travel **MUST** be checked. The air valve stem must be engaged and moved back slightly before the trigger engages the trigger adjustment nut. If this does not occur then the trigger adjustment nut and/or the trigger set screw must be adjusted. The 11/16-inch dimension is only a starting place for trigger adjustment and can be altered to obtain proper triggering sequence.

HANDLE / PLUG ASSEMBLY

Removal

1. The following procedures must be performed prior to removing the handle:

- Barrel removal
- Low Voltage Cable removal
- Fluid/Air Hose removal

2. Remove the gasket from the handle; if it was not removed with the barrel.

3. Remove the fan air adjustment valve, pull the rear cover straight off.

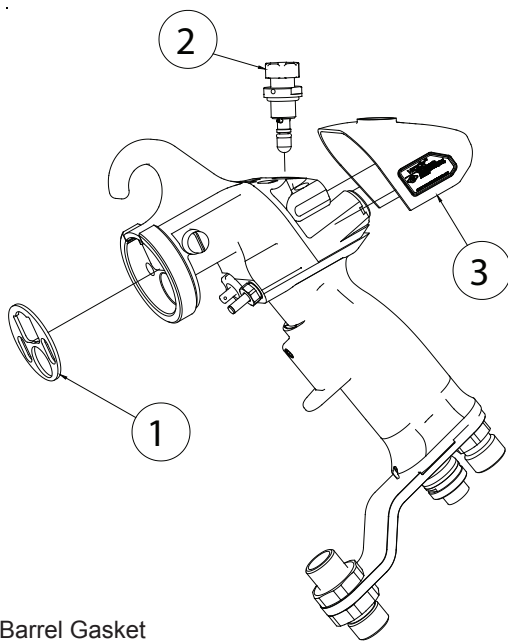

- 1 - Barrel Gasket
- 2 - Fan Air Adjustment Valve
- 3 - Rear Cover

Figure 31: Air Valve and Rear Cover Removal

4. Remove the air valve retaining cap and o-ring. Remove the air valve return spring. From the front of the applicator, push the air valve out the rear of the applicator. Remove the air valve retaining nut and seal from the base of the applicator.

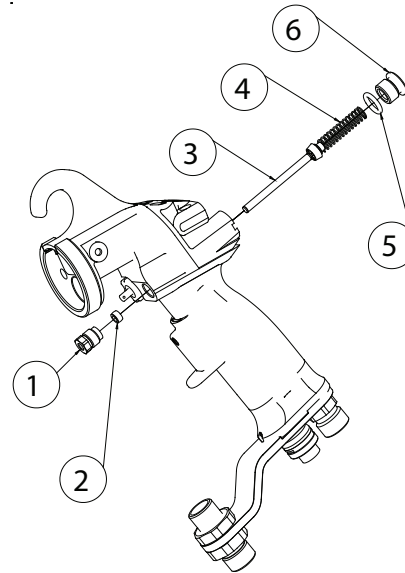

- 1 - Air Valve Retaining Nut
- 2 - Seal (opening toward applicator rear)
- 3 - Air Valve
- 4 - Air Valve Return Spring
- 5 - Solvent Proof O-Ring
- 6 - Air Valve Retaining Cap

Figure 32: Air Valve Removal

5. Remove the hook and hook gasket. Loosen the plug assembly setscrew and pull the plug assembly straight out of the applicator.

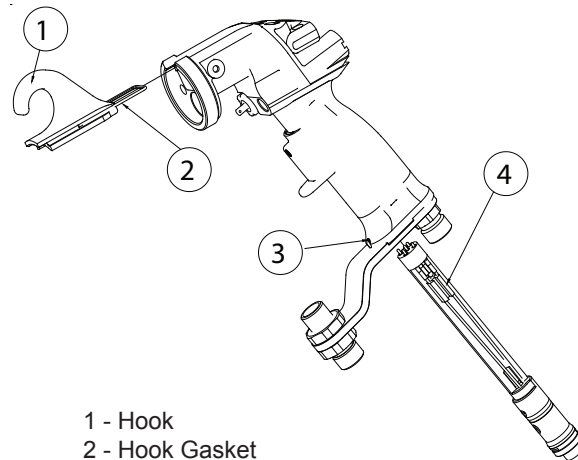

- 1 - Hook
- 2 - Hook Gasket
- 3 - Plug Assembly Set Screw (loosen)
- 4 - Plug Assembly (pull straight out)

Figure 33: Hook and Plug Assembly Removal

6. Remove the air inlet fitting and the fluid bracket from the base of the applicator.

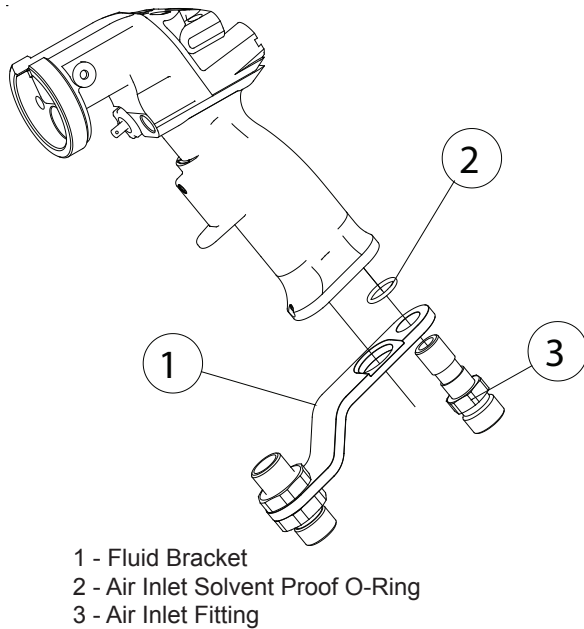

Figure 34: Fluid Bracket Removal

7. Remove the trigger shelf by removing the set screw with a 3/32" Allen wrench. Push down on the shelf to remove.

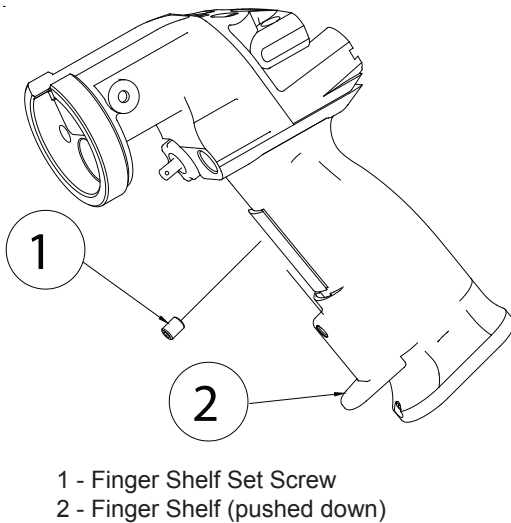

Figure 35: Trigger Shelf Removal

8. Remove the trigger stop by turning the knob of the stop counter-clockwise until the thread of the stop is completely disengaged.

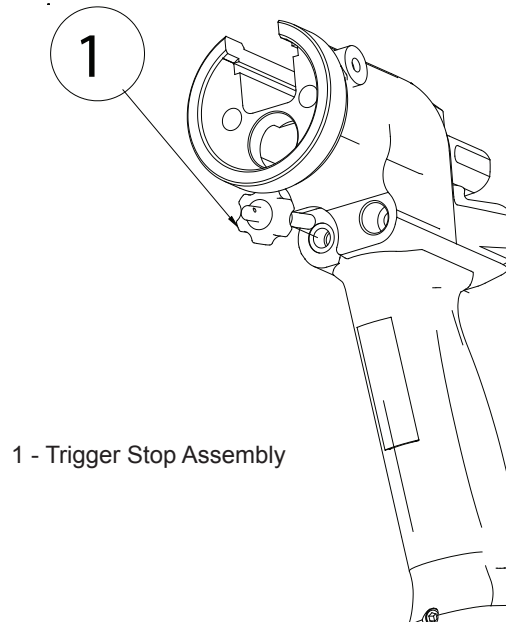

Figure 36: Trigger Stop Removal

Reassembly

(Refer to Figures 31, 32, 33, 34, 35, 36, 37, and 38)

1. Screw the trigger stop into the handle in a clockwise direction.
2. Push the finger shelf up on the dovetail pad on the handle to the desired height, insert the set screw and tighten with a 3/32" Allen wrench.
3. Insert the fluid bracket over the air fitting, then install the o-ring over the air fitting. Tighten the air fitting in a clockwise direction.

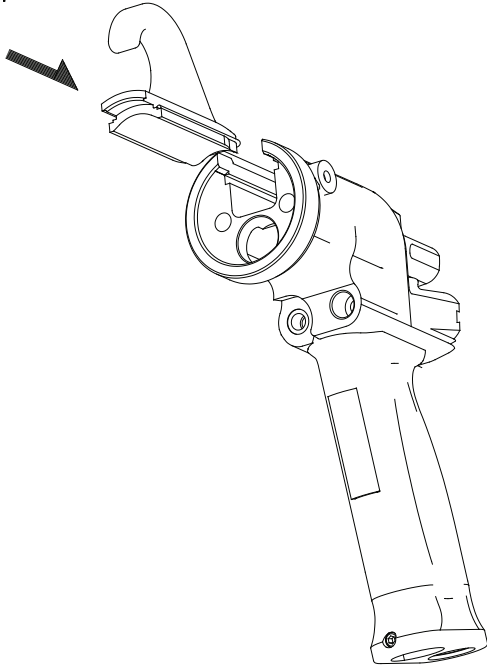

Figure 37: Hook Insertion Into Handle

4. Push the hook gasket into the groove of the hook. Apply a light coat of dielectric grease (LSCH0009) to the hook gasket exterior and slide the hook into position.

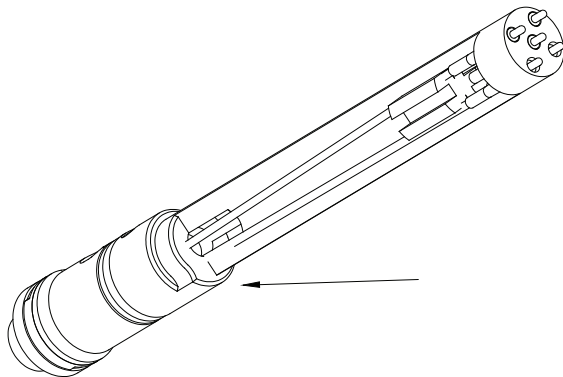

Figure 38: Low Voltage Plug Locating Tab

5. Reinstall the air valve components in the reverse order of disassembly.

6. Push the rear cover onto the back of the handle. Secure the cover by inserting the fan air adjustment valve into the handle and tighten in the clockwise direction.

7. Insert the barrel gasket back into the handle.

8. Insert the plug assembly into the base of the handle. Align the raised portion into the mating handle recess.

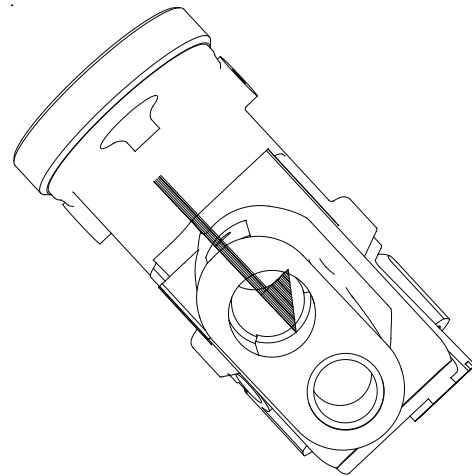

Figure 39: Location of Handle Low Voltage Plug Recess

TROUBLESHOOTING GUIDE

General Problem	Possible Cause	Solution
DEFECTIVE SPRAY PATTERN		
Pattern Will Not Shape	Clogged or faulty fan air valve	Clean, repair, or replace.
	Air passages in applicator or air line clogged	Blow out, clean, or replace.
	Worn, faulty, or clogged air cap	Clean or replace.
	Barrel restrictor missing	Replace barrel restrictor.
Pattern Heavy At One End	Clogged or faulty air cap	Clean or replace.
	Clogged or faulty fluid nozzle	Clean or replace.
Extremely Heavy Spitting or Severely Deformed Pattern	Wrong air cap/fluid nozzle combination	Ensure proper fluid nozzle/air nozzle pressure reducer combinations (see "Fluid Nozzle Tables" in the "Installation" section).
	Faulty air cap	Replace.
INADEQUATE DELIVERY		
Air	Air passages in applicator or air line clogged	Blow out.
	Inadequate air source	Increase pressure, flow capacity.
	Paint in air passage	Clean and blow out.
Fluid	Clogged or faulty fluid nozzle	Flush or replace.
	Clogged passages in applicator fluid tube or fluid line	Flush.
	Insufficient needle/electrode travel	Adjust (see "Trigger Adjustment Nut Dimension Figure" in the "Maintenance" section).
	Low fluid supply pressure	Increase.
	Clogged fluid filter	Clean or replace.
	Clogged or obstructed valve or fluid regulator	Clean as required or replace.

(Continued On Next Page)

TROUBLESHOOTING GUIDE (Cont.)

General Problem	Possible Cause	Solution
LEAKAGE		
Air	Defective valve seat or valve spring	Clean and lubricate or replace.
Fluid (At rear of barrel)	Cartridge seal assembly and/or needle/electrode shaft defective	See "Barrel Assembly" in the "Maintenance" section.
Fluid (Slight leak at nozzle when trigger is released)	Nozzle not secure	Tighten.
	Air valve closing before fluid valve	Adjust needle shaft/electrode travel.
Fluid (Constant at nozzle)	Worn or damaged fluid nozzle	Replace fluid nozzle.
	Worn or damaged needle/electrode	Replace.
	Loose fluid nozzle	Tighten.
	Needle/electrode does not seat when trigger is released	Adjust (see "Trigger Adjustment Nut Dimension Figure" in the "Maintenance" section).
ELECTRICAL		
Wrap Back	Improper target ground	Trace and correct (1 megohm maximum ground to target resistance).
	Improper spray technique	See Ransburg "Applicator Spray Techniques" manual.
	Improper booth exhaust	Trace and correct.
	Excessive atomizing air	Reduce pressure.
	Excessive target distance	Decrease distance between applicator and target.
Improper or No High Voltage	Is the power turned on?	Check and secure at the applicator and at the control unit.
	Is the atomizing air turned on?	Trace and correct.
	Is the applicator triggered?	Replace.
	Blown fuse	Replace.
	Faulty high voltage cable connections	Replace.
	Is the paint too conductive?	Clean as required per suggested "Maintenance Schedule".

(Continued On Next Page)

TROUBLESHOOTING GUIDE (Cont.)

General Problem	Possible Cause	Solution
ELECTRICAL (Continued)		
Improper or No High Voltage (Cont.)	Blown fuse	Replace fuse.
	Is the power turned on?	Check power supply.
	Is the atomizing air turned on?	Check air regulator.
	Is the applicator triggered?	Check applicator trigger.
	Is the applicator switch on?	Check applicator switch.
	Is the paint too conductive?	Check conductivity of paint.
	Faulty flow switch	Replace flow switch.
Isolation System Grounded Out	Failed fluid hose	Replace fluid hose.
	Insulation stand or charged equipment too close to ground	Provide adequate ground distance.

PARTS IDENTIFICATION

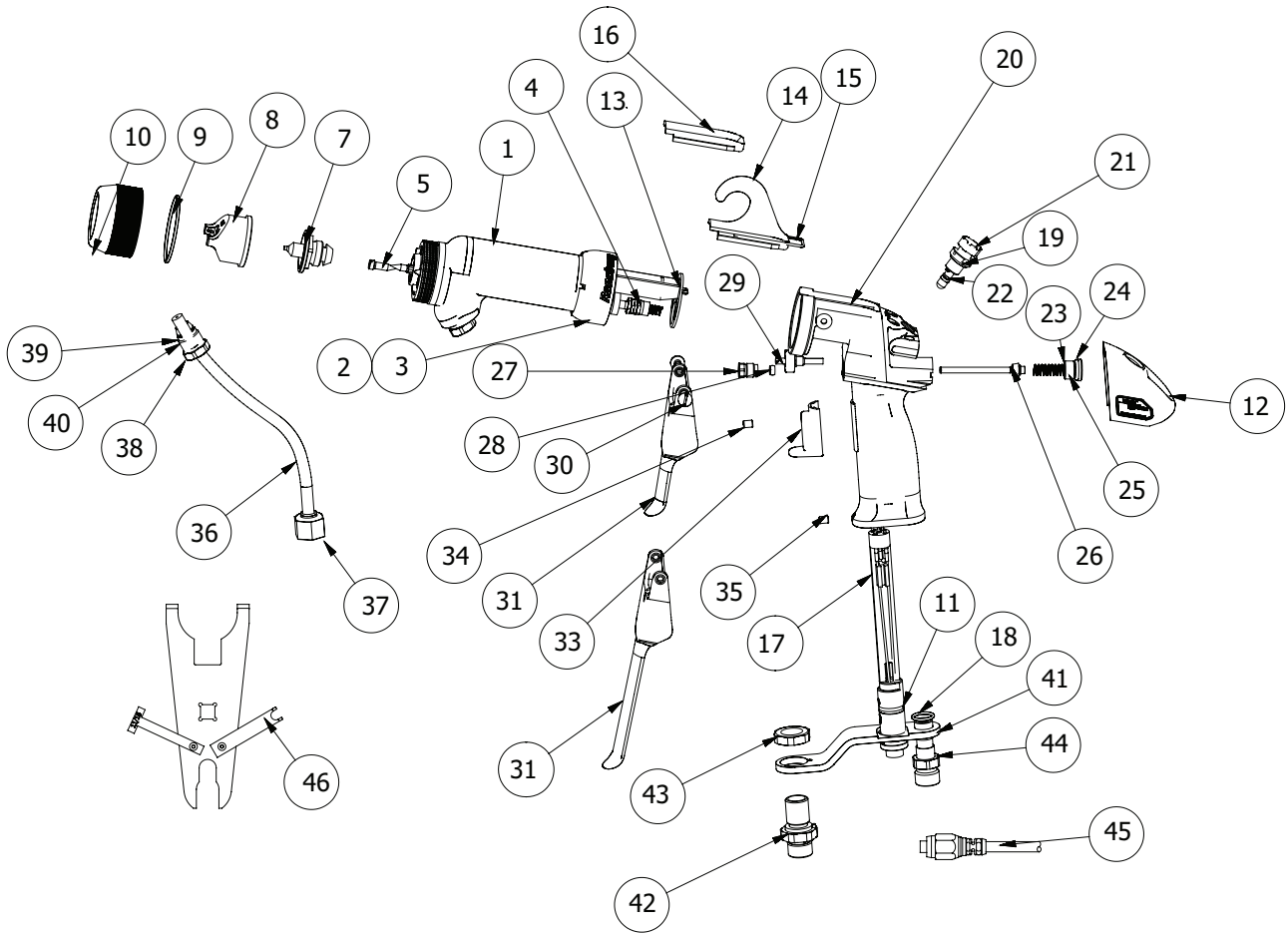

Figure 40: R90/70 Cascade Solventborne Applicator Breakdown

R90/70 CASCADE SOLVENTBORNE APPLICATOR - PARTS LIST (Figure 40)			
Item #	Part #	Description	Qty
1	79468-00	Barrel, Machined, R90	1
	79469-00	Barrel, Machined, R70	1
2	79373-00	Nut, Retaining Barrel	1
3	75326-00	Ring, Retaining	1
4	79599-01	Needle Shaft Assembly, R90, 2k Packings (Std.)	1
	79599-02	Needle Shaft Assembly, R70, 2k Packings (Std.)	1
5	Table D-"D3"	Restrictor, Standard Air Spray (Black)	1
6	--	--	--
7	Table D-"D2" *	Nozzle, Fluid	1
8	Table D-"D1" **	Cap, Air	1
9	LSOR0005-17	O-Ring, PTFE Encapsulated	1
10	79379-00	Nut, Retaining, Air Nozzle	1
11	79001-09	O-Ring, Solvent Proof	1
12	79471-01	Assembly, Rear Cover	1
13	79378-00	Gasket, Barrel Cover	1
14	79322-00	Hook, Molded	1
15	79479-00	O-Ring, Cord, Solvent Proof	1
16	79322-11	Hook, Molded	1
17	79460-03	Assembly, Plug	1
18	79001-08	O-Ring, Solvent Proof	2
19	79001-07	O-Ring, Solvent Proof	2
20	79476-00	Handle, Assembly	1
21	79445-10	Fan Air Adjust, Assembly	1
22	79001-16	O-Ring, Solvent Proof	1
23	17130-00	Spring, Return	1
24	79001-31	O-Ring, Solvent Proof	1
25	79453-00	Cap, Retaining, Air Valve	1
26	79310-00	Air Valve, Assembly	1
27	78635-00	Nut, Retaining, Air Valve	1
28	10051-05	Cup Seal, Spring Loaded	1
29	79560-00	Trigger Stop, Assembly	1
30	79454-00	Screw, Trigger Retention	2
31	Table B-"B1"	Trigger, Molded	1
32	--	--	--
33	79324-00	Shelf, Finger Molded	Table B-"B2"
34	19603-8F	Set Screw, Cup Point	Table B-"B2"
35	19603-10F	Set Screw, Cup Point	1
36	Table C-"C4"	Tube, Fluid	1
37	3587-03	Nut and Ferrule	Table C-"C5"
38	79385-00	Nut, Connector, Hose	Table C-"C5"
39	EMF-202-05	Ferrule, Back, 3/8" Tube	Table C-"C5"
40	EMF-203-05	Ferrule, Front, 3/8" Tube	Table C-"C5"
41	Table C-"C2"	Bracket, Support	1
42	Table C-"C1"	Fitting, Fluid (Straight Offset Bracket)	1
43	Table C-"C3"	Nut, Hex	1

* See "Fluid Nozzle Selection Chart" in the "Installation" section.

** See "Air Cap/Fluid Nozzle Selection Chart" in the "Installation" section.

(Continued On Next Page)

R90/70 CASCADE SOLVENTBORNE APPLICATOR - PARTS LIST (Figure 40) (Cont.)			
Item #	Part #	Description	Qty
44	18847-01	Fitting, Air Inlet, 1/4" NPSM(M) (Std.)	1
	18847-00	Fitting, Air Inlet, 3/8" NPSM(M) (Optional)	1
45	Table A - "A2"	Cable, Low Voltage, Vector	Table A - "A1"
46	19749-00	Special Applicator Wrench	1
47	72315-00	Conductive Ferrule	1
48	6241-06	Fitting, Fluid	1
49	7787-03	Swivel Fitting	1

TABLE A LOW VOLTAGE CABLE LENGTHS			
"A" Dash #	Description	"A1"	"A2"
0	No Cable	0	--
1	10m	1	79338-10
2	15m	1	79338-15
3	20m	2	79338-10
4	25m	1	79338-10
		1	79338-15
5	30m	2	79338-15

TABLE B TRIGGER TYPE			
"B" Dash #	Description	"B1"	"B2"
2	2-Finger Trigger	79325-02	1
4	4-Finger Trigger	79325-04	0

TABLE C FLUID DELIVERY COMBINATION						
"C" Dash #	Description	"C1"	"C2"	"C3"	"C4"	"C5"
1	Offset Bracket, .093" ID Fluid Tube	70399-00	79438-00	10553-06	9704-16	1
2	45° Bracket, .093" ID Fluid Tube	70442-00	79439-00	10553-06	9704-16	1
3	Offset Bracket (SS), .093" ID Fluid Tube	70399-00	79438-01	10553-06	9704-16	1
4	Offset Bracket, .250" ID Fluid Tube	70399-00	79438-00	10553-06	9704-11	1
5	45° Bracket, .250" ID Fluid Tube	70442-00	79439-00	10553-06	9704-11	1
6	Offset Bracket (SS), .250" ID Fluid Tube	70399-00	79438-01	10553-06	9704-11	1
7	Offset Bracket, .125" ID Coiled Fluid Tube	79650-00	79438-00	10553-05	79871-00	0

TABLE D - SPRAY SELECTION				
D Dash #	Description	"D1"	"D2"	"D3"
0	Standard Spray, 65V Air Cap, 1.4mm Fluid Nozzle, #44	79374-65	79377-44	74963-05
1	Standard Spray, 65V Air Cap, 1.8mm Fluid Nozzle, #45	79374-65	79377-45	74963-05
2	Trans-Tech., 122V Air Cap, 1.8mm Fluid Nozzle, #245	79374-122	79552-245	74963-06
3	Round Spray	79962-00	79959-00	74963-04

TABLE E CONTROL UNIT		
Dash No.	Description	Control Unit
0	Applicator with Cable Only, No Power Supply	--
1	Domestic Sales, 110/120 V	79344-1X1
2	Export Sales, 240 V - 50/60 Hz	79344-1X2

VECTOR R90/R70 CASCADE SOLVENTBORNE MODEL IDENTIFICATION

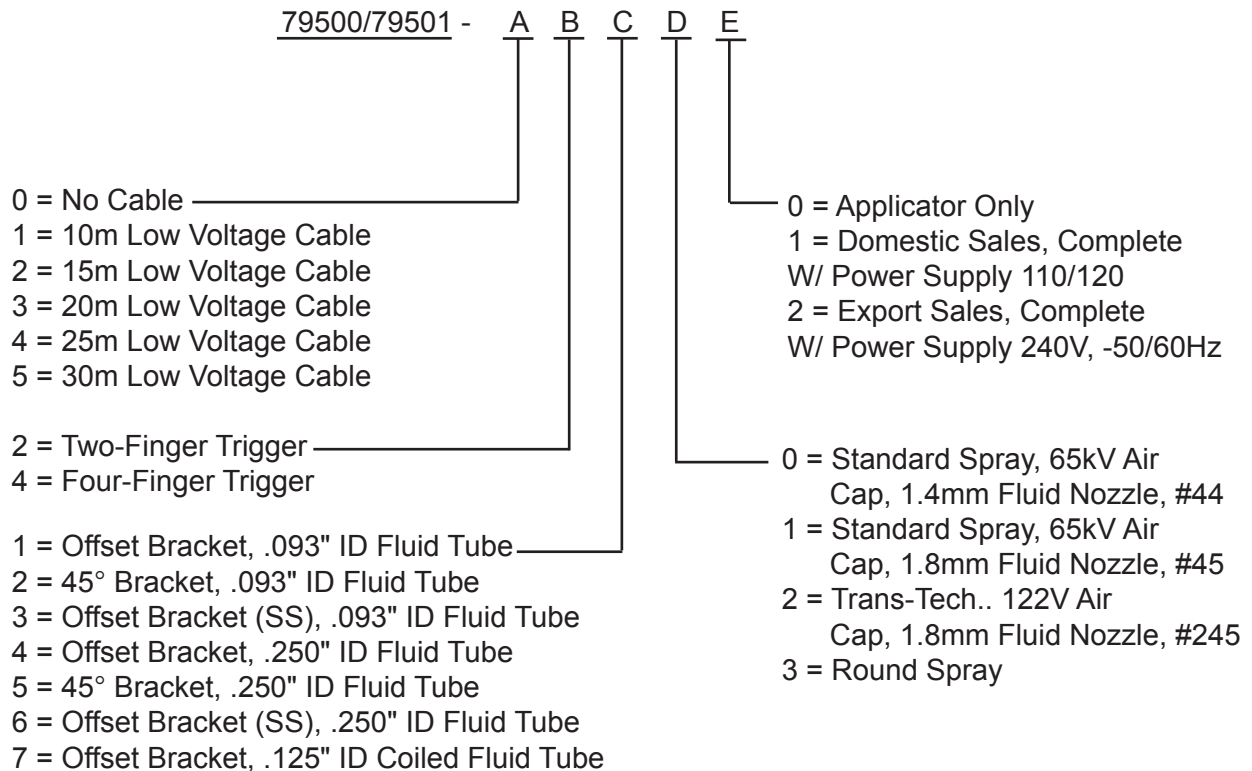

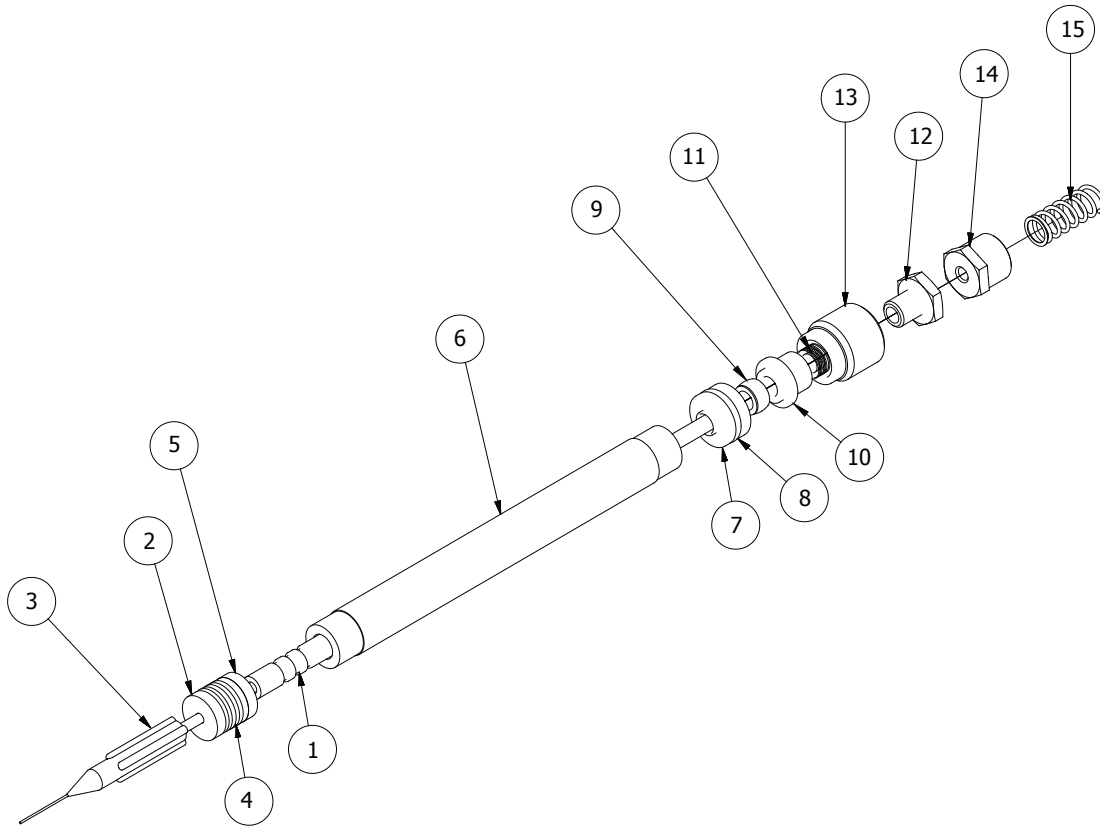

Figure 41: R90 (79599-01) and R70 (79599-02) Cascade Needle Shaft (2k Packings)-Standard

R90 (79599-01) AND R70 (79599-02) CASCADE NEEDLE SHAFT (STANDARD 2K PACKINGS) - PARTS LIST (Figure 41)			
Item #	Part #	Description	Qty
1	78627-04	Shaft Assembly, 2-Piece Needle, R90, 2k Packings	1
	78627-05	Shaft Assembly, 2-Piece Needle, R70, 2k Packings	
2	74653-00	Adapter, Male Chevron	1
3	70430-01	Electrode, High Wear	1
4	14323-00	Seal, Chevron	4
5	18821-00	Adapter, Female Chevron	1
6	18842-01	Tube, Packing, R90	1
	18842-02	Tube Packing, R70	
7	78629-00	Retainer, Needle Seal, Rear	1
8	79001-06	O-Ring, Solvent Proof	1
9	10051-05	Cup Seal, Spring Loaded	1
10	78630-00	Spacer, Seal	1
11	17390-04	Washer, Beville Spring	6
12	78632-00	Nut, Locking Trigger Adjustment	1
13	78631-00	Nut, Packing	1
14	78633-00	Spring Retainer, Needle Shaft	1
15	78824-00	Spring	1
16	SI-07-03	Service Instruction	1

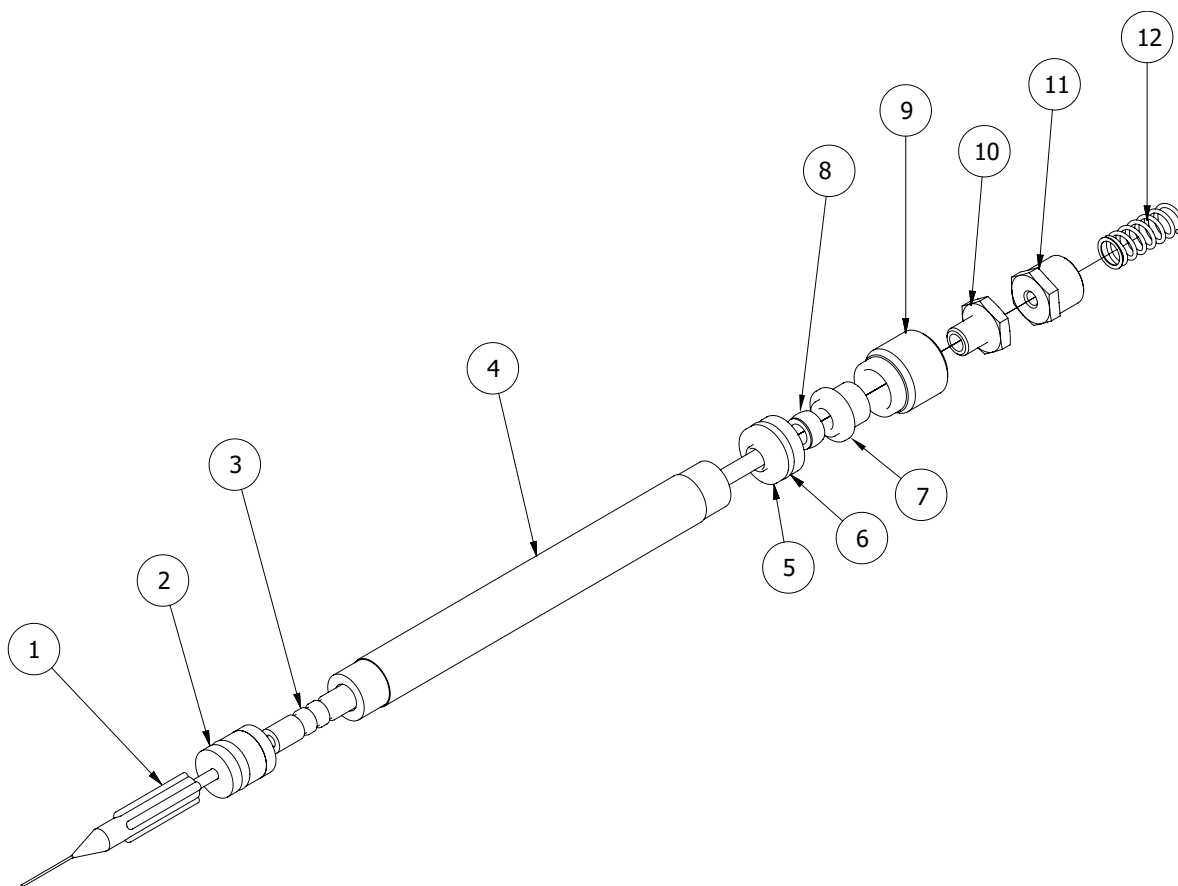

Figure 42: R90 (78628-11) and R70 (78628-12) Cascade Needle Shaft (Optional Packings)

R90 (78628-11) AND R70 (78628-12) CASCADE NEEDLE SHAFT (OPTIONAL PACKINGS) - PARTS LIST (Figure 42)			
Item #	Part #	Description	Qty
1	70430-01	Electrode, High Flex	1
2	78626-00	Seal Cartridge Non-Adj., Assembly	1
3	78627-04	Shaft Assembly, 2-Piece Needle, R90, Standard Packings	1
	78627-05	Shaft Assembly, 2-Piece Needle, R70, Standard Packings	1
4	18842-01	Tube, Packing, R90	1
	18842-02	Tube, Packing, R70	1
5	78629-00	Retainer, Needle Seal, Rear	1
6	79001-06	O-Ring, Solvent Proof	1
7	78630-00	Spacer, Seal	1
8	10051-05	Cup Seal, Spring Loaded	1
9	78631-00	Nut, Packing	1
10	78632-00	Nut, Locking Trigger Adjustment	1
11	78633-00	Spring, Retainer, Needle Shaft	1
12	78636-00	Spring	1



WATERBORNE APPLICATOR MODEL 79523-XXXX SECTION

! WARNING

- Typical installations to spray non-flammable conductive materials (waterborne materials) must not be used to handle flammable materials (solvent based materials).



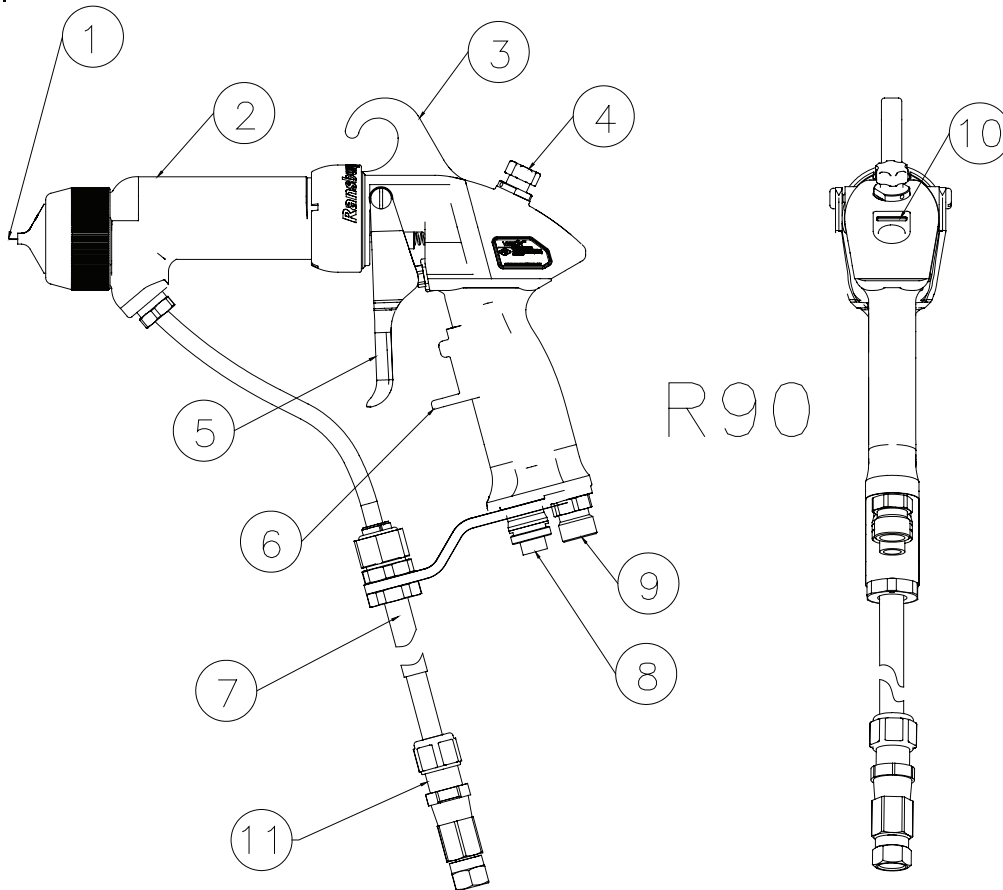

Figure 43: R90 Cascade Waterborne Electrostatic Spray Applicator Features

R90 CASCADE WATERBORNE ELECTROSTATIC SPRAY APPLICATOR FEATURES (Figure 43)			
No.	Description	No.	Description
1	Needle/Electrode	7	Waterborne Hose
2	Barrel	8	Low Voltage Cable Connection
3	Replaceable Hook	9	Air Hose Connection
4	Fan Air Adjust	10	kV Setpoint Switch/Microamp Display
5	2-Finger/4-Finger Trigger	11	Waterborne Source Connection
6	Adjustable Trigger Shelf		

79523 R90 CASCADE WATERBORNE SPECIFICATIONS



79513-1XX 9050 POWER SUPPLY ELECTRICAL SPECIFICATIONS

Environmental/Physical

Gun Length:	27cm (10.7 inches)
Weight:	735 grams (25.9 oz.)
Hose & Cable Lengths (Std):	10m, 15m, 20m, 25m, and 30m
Atomizer Nozzle Assembly (Std):	79374-65, 79377-45

Electrical

Operating Voltage:	85 kV DC (-) maximum
Current Output:	100 microamperes maximum
Part Sprayability:	Determine sprayability of part to be coated using 76652, Test Equipment
(See current "Paint, HV & SCI Test Equipment" service manual.)	

Mechanical

Fluid Flow Capacity:	1000 cc/minute**
Operating Pressure (Air Spray)	
Fluid:	(0-6.9 bar) 0-100 psi
Air:	(0-6.9 bar) 0-100 psi
Ambient Temp.:	40°C to 12.8°C
Consumption:	510 slpm (18.0 SCFM) @ 3.4 bar (50 psig) inlet
Sound Level:	92dB (A) @ 50 psig inlet, 1m from applicator
** This reflects the maximum fluid volume the applicator can deliver. The maximum spray volume that can be effectively atomized depends on fluid rheology, spray technology, and finish quality required.	

Electrical

Input Voltage:	100-240 VAC
Current:	1 A maximum RMS
Frequency:	50/60 Hz
Wattage:	40 watts (max.)
Output Voltage:	20-85 kV DC (79513-12X)
Current:	100 microamps (max.) (79513-12X)

Physical

Height:	14.0cm (5.5-inches)
Width:	21.6cm (8.5-inches)
Depth:	19.1cm (7.5-inches)
Weight:	3.4 kg (7.5 lbs.)

Pneumatic

Supply Air:	6.9 bar (100 psig) maximum
--------------------	----------------------------

CONTROL UNIT INPUTS / OUTPUTS		
9050 Part #	Voltage Designation	Maximum Output
79513-121	110/120 VAC	-85 kV DC
79513-122	220/240 VAC	-85 kV DC

CONTROL UNIT / APPLICATOR COMBINATIONS	
9050 Part #	For Use With Applicator Combinations
79513-12X	79523-XXXXX

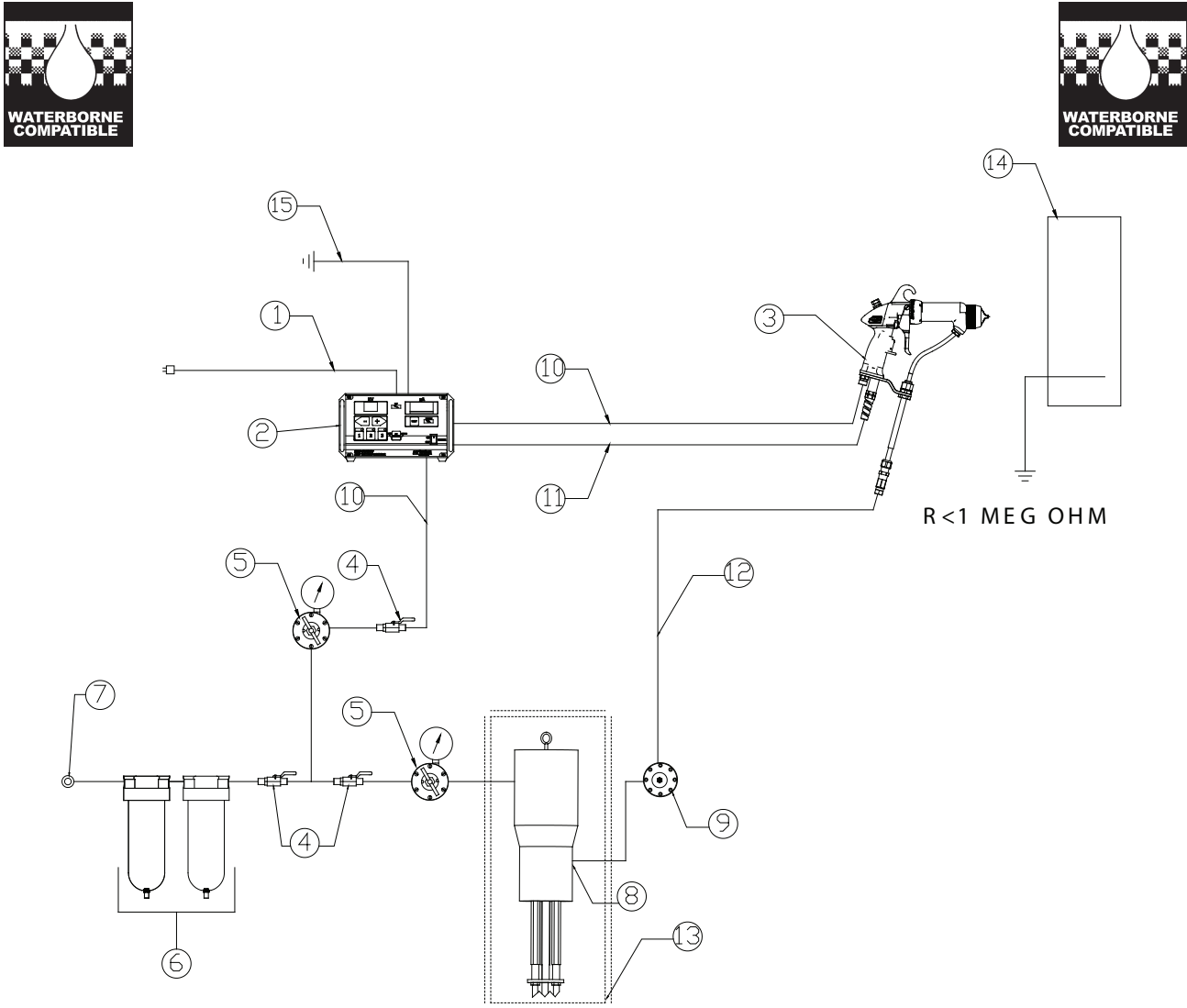

Figure 44: R90 Cascade Waterborne Typical Installation

R90 CASCADE WATERBORNE TYPICAL INSTALLATION			
No.	Description	No.	Description
1	AC Line Cord (110/220)	9	Fluid Regulator
2	9060 Power Supply	10	Air Line
3	Vector Applicator	11	Low Voltage Cable
4	Ball Valve	12	Fluid Valve
5	Air Regulator W/Pressure Gauge	13	Isolated Fluid System (Protection required from human contact.)
6	Air/Water Separator		
7	Main Air Supply Line	14	Target (Earth or Building Ground)
8	Fluid Supply (Grounded)	15	9060 Ground (Separate Earth or Building Ground)

**WARNING**

► Typical installations to spray non-flammable conductive materials (waterborne materials) must not be used to handle flammable materials (solvent based materials).

WATERBORNE ISOLATION SYSTEM INSTALLATION GUIDELINES

Using waterborne coating with electrostatic equipment requires that the fluid source be isolated from ground. Precautions should be taken to ensure operator safety and system efficiency. The following guidelines should be followed:

- The fluid lines and source MUST be isolated from ground. An isolating Paint Stand or similar isolating (non-porous) material MUST be used.

**CAUTION**

► Never use wood products, wooden boxes, pallets, or boards as an isolator. Wood contains moisture and is a poor insulator. Electrical current passing through these materials can ignite them, causing a hazardous condition.

- Isolation stands MUST be at least 18-inches from grounded booth walls, chain link fences, or other grounded objects.
- Air hoses to the pressure pot or pump on the insulating stand should be non-conductive plastic. Many rubber hoses will have static grounding circuits or carbon content and are NOT suitable for this application.

- All charged (isolated) systems MUST be inside a fence or cage to prevent contact by personnel. An interlock system MUST be provided that interrupts high voltage flow to the applicator if the gate is opened.
- Air regulators for pots or pumps should be mounted remotely outside the fence or cage area to facilitate changes in pressure without shutting the system down.
- Grounding hooks at the cage MUST be used to ground the system when personnel are working close by.
- Fluid lines to the applicator MUST be protected from scraping and abrasion on the floor or sharp metal edges that could lead to voltage pinholing and loss of kV on the charged system.
- Cleanliness and maintenance are extremely critical.
- Refer to "Installation - 79500 R90 Solventborne, 79501 R70 Solventborne Installation" in the "Installation" section of this manual.

WATERBORNE HOSE FITTING INSTALLATION

For 79523 R90 Cascade - Waterborne: Ransburg supplies the waterborne fluid hose factory pre-assembled to the applicator unit. Standard hose lengths are 10m, 15m, and 25m. To modify the hose length, use the following procedures. All adjustments must be made at the supply end of the system.

1. Remove the male connector and swivel fitting from the end of the fluid hose by turning the nut of the male connector counter-clockwise while holding its main body.
2. Remove the male connector nut from the fluid hose.
3. Determine the hose length that is needed and cut the hose off squarely.

**WARNING**

➤ Special care must be taken when removing the sheathing from the fluid hose. Make sure all tools are very sharp and only score the surface of the sheath. Inserting the knife too deep can score the surface of the core material and lead to pin-holing and failure of the hose.

NOTES

4. Carefully score the outer jacket linearly and then radially approximately 18-inches back from the cut end. Split the outer jacket along the linear score mark and peel it away from the inner sheath. Then remove the jacket completely by tearing along the radial score mark.

5. Lightly score the inner sheath linearly and then radially 1-inch from the outer jacket. Split the inner sheath along the linear score mark and peel it away from the core fluid hose. Then remove the sheath completely by tearing along the radial score mark.

6. Roll the inner sheath back over itself until it touches the outer jacket.

7. Cut approximately 1/4-inch of inner sheath off.

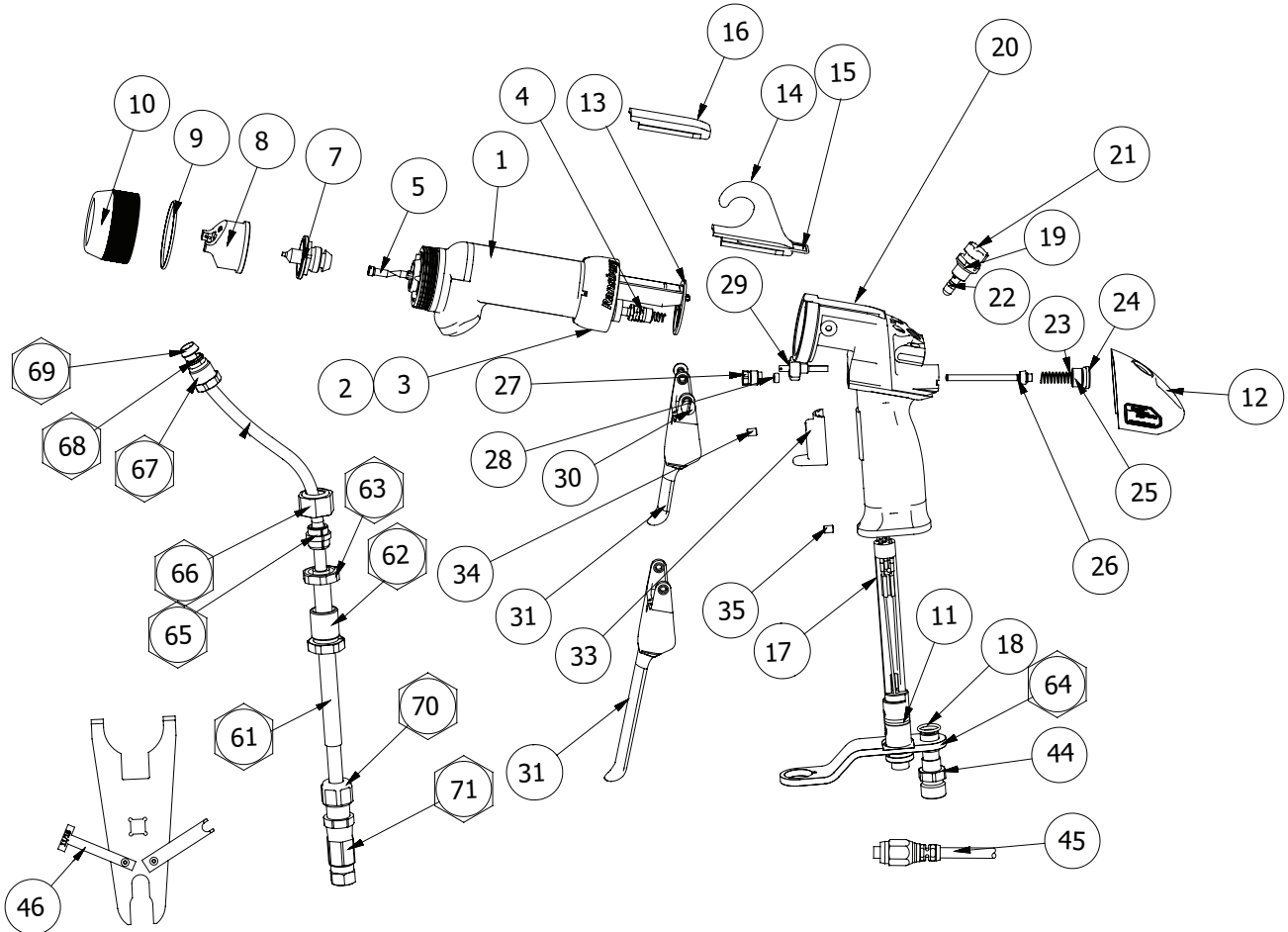

XX refer to parts list for figure 56

XX refer to parts list figure 50

Figure 45: Waterborne Fluid Delivery Components

WATERBORNE FLUID DELIVERY COMPONENTS - PARTS LIST (Figure 45)			
Item #	Part #	Description	Qty
61	Table F - "F"	Fluid Hose, Assembly, Vector *	1
61a	74179-XX	Bulk Tube, Fluid, 1/4" ID	XXm
	72307-XX	Bulk Tube, Fluid, 3/16" ID	XXm
62	72310-00	Connector, Bulk Head	1
63	10553-05	Nut, Hex	1
64	79438-00	Bracket, Support, Offset (Std.)	1
	79438-01	Bracket, Support Offset (Stainless Steel) (Optional)	1
65	72315-00	Conductive Ferrule	1
66	3587-02	Nut, 3/8"	1
67	79385-00	Nut, Connector, Hose	1
68	EMF-203-05	Tube, Ferrule, Front, 3/8"	1
69	EMF-202-05	Tube, Ferrule, Back, 3/8"	1
70	6241-06	Fitting, Fluid	1
71	7787-03	Swivel Fitting	1

* Includes Item # 61a, 63, 65, 66, 70, and 71.

TABLE F WATERBORNE FLUID HOSE LENGTHS AND ID		
Dash #	Description	"F"
0	No Fluid Hose	--
1	10m, 1/4" ID	79525-10
2	10m, 3/16" ID	79524-10
3	15m, 1/4" ID	79525-15
4	15m, 3/16" ID	79524-15



VECTOR R90 CASCADE WATERBORNE MODEL IDENTIFICATION

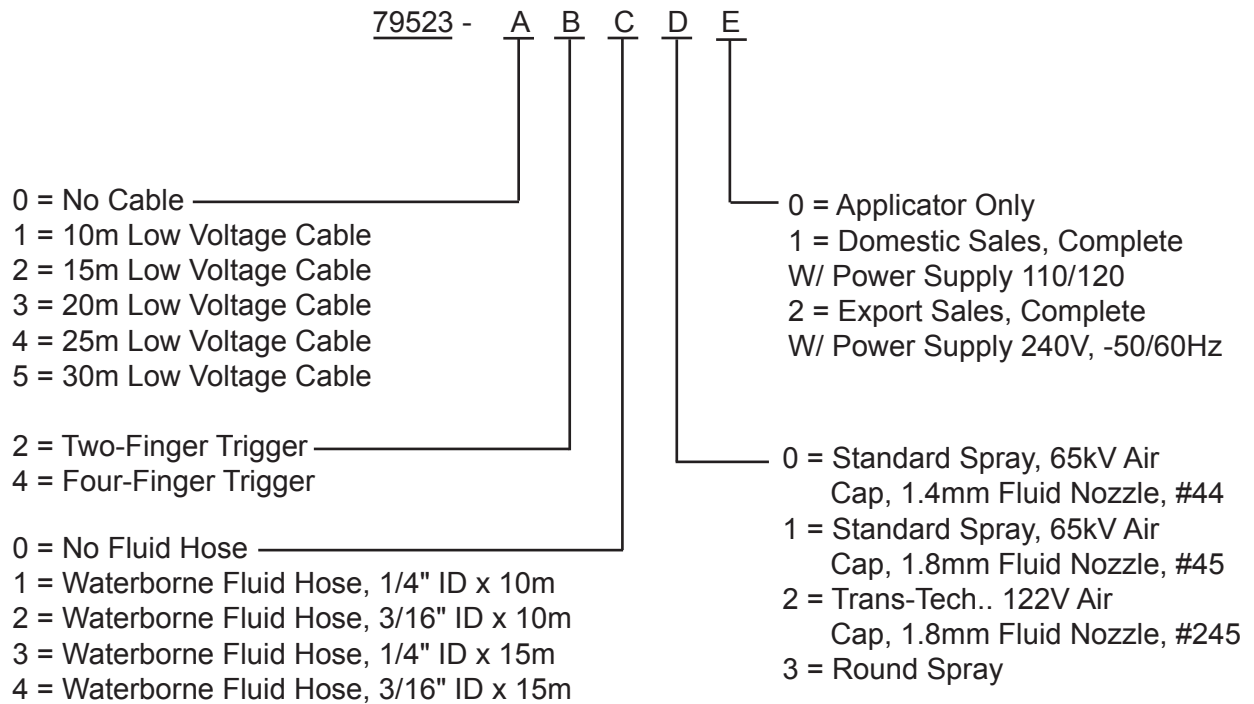

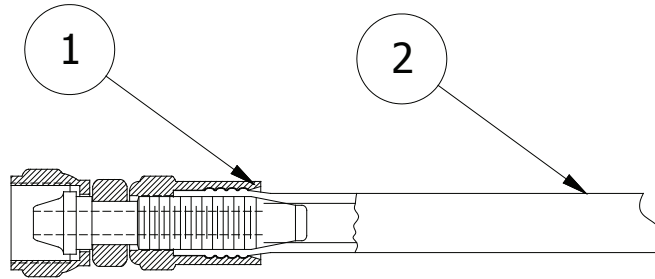

Figure 46: Optional Air Hose

VECTOR AIR HOSE OPTIONS - PARTS LIST (Figure 46)			
Item #	Part #	Description	Qty
	79547-10	Air Hose Assembly, 10m (33')	
	79547-15	Air Hose Assembly, 15m (49')	
	79547-20	Air Hose Assembly, 20m (66')	
	79547-31	Air Hose Assembly, 30m (99')	
1	LSFI0027	Reusable Hose Fitting	1
2	6919-XX	Bulk Hose, Air	XX

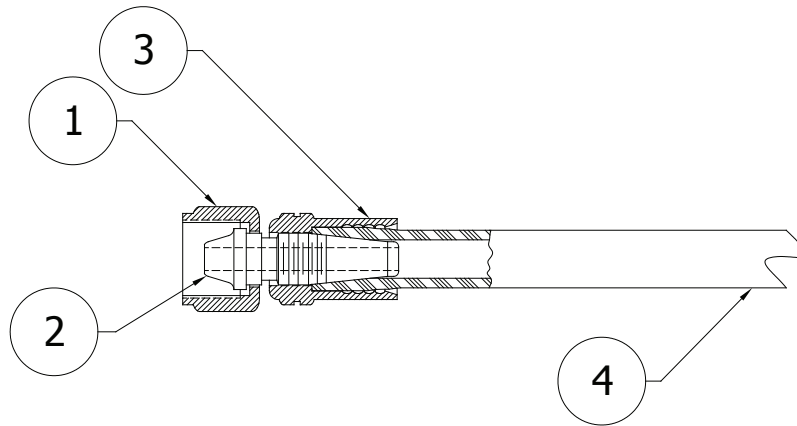

Figure 47: Optional Fluid Hose

VECTOR FLUID HOSE OPTIONS - PARTS LIST (Figure 47)			
Item #	Part #	Description	Qty
	79548-10	Fluid Hose Assembly, 10m (33')	
	79548-15	Fluid Hose Assembly, 15m (49')	
	79548-20	Fluid Hose Assembly, 20m (66')	
	79548-31	Fluid Hose Assembly, 30m (99')	
1	14599-00	Nut	1
2	7623-00	Union Stem	1
3	7617-00	Ferrule	1
4	77031-XX	Bulk Hose, Fluid	XX

VECTOR APPLICATOR COVER OPTIONS - PARTS LIST			
Item #	Part #	Description	Qty
1	79529-00	Applicator Cover	1
	79529-00-K5	Applicator Cover, Package of 5	

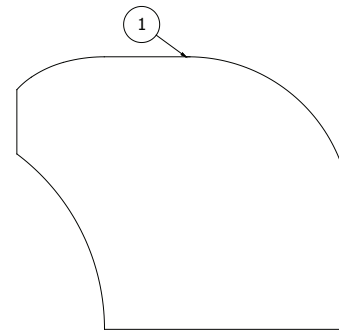

Figure 48: Applicator Cover

VECTOR SWIRL NOZZLE OPTIONS - PARTS LIST			
Item #	Part #	Description	Qty
1	79959-00	Fluid Nozzle Assembly	1
2	79962-00	Air Cap, Swirl	1

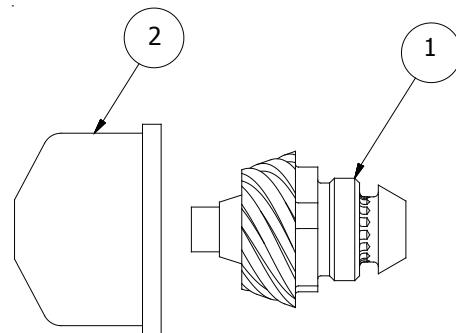

Figure 49 - Swirl Nozzle

VECTOR FLUID TUBE OPTIONS		
Part #	Description	Qty.
9704-16	.093" ID Tube (Standard W/Applicator)	See "Item 36"
9704-05	.125" ID Tube	See "Item 36"
9704-11	.250" ID Tube	See "Item 36"

NOTE: The standard fluid delivery tube is the smallest diameter to work best with highly conductive materials, down to .1 megohm resistance. If higher fluid flows are required, the larger diameter tube either .125-inch or .250-inch may be used, but depending on material conductivity, the current draw during the spray operation may increase.

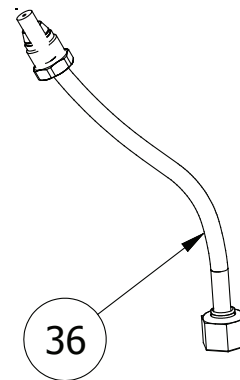

Figure 50: Fluid Tube

LOW VOLTAGE CABLE OPTION		
Part #	Description	Qty.
79338-01	Low Voltage Cable, 1 Meter	1



Figure 51: Low Voltage Cable

PARTS COMPARISON

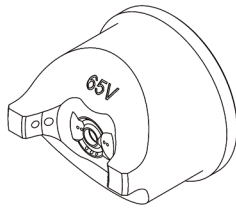

79374-65 Standard Air Spray Air Cap



79374-122 Trans-Tech. Air Spray Air Cap

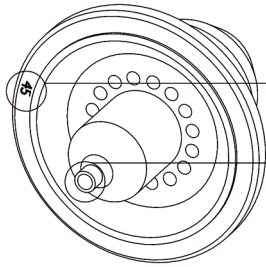

79377-XX Standard Air Spray Fluid Nozzle

Standard Air Spray Nozzles have a number between 44 and 148; Trans-Tech. Air Spray Nozzles have a number between 244 and 348.

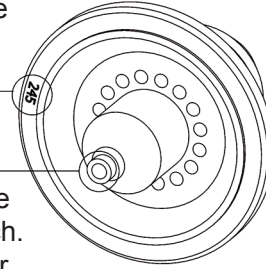

79552-XXX Trans-Tech. Air Spray Fluid Nozzle

Standard Air Spray Nozzles have a longer, narrower tip; Trans-Tech. Air Spray Nozzles have a shorter, wider tip, and have a shorter overall length.

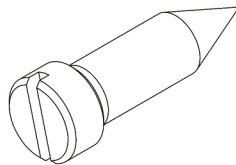

74963-05 Standard Air Spray Restrictor

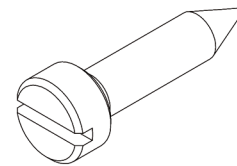

74963-06 Trans-Tech. Air Spray Restrictor

TRANS-TECH. ATOMIZATION - PARTS LIST			
Item #	Part #	Description	Qty
1	79379-00	Nut, Retaining, Air Nozzle	1
2	79374-65	Standard Air Spray Cap, Air	1
	79374-122	Trans-Tech. Air Spray Cap, Air (Included in 79555 Kit)	
3	79377-XX	Standard Air Spray Nozzle, Fluid	1
	79552-XXX	Trans-Tech. Air Spray Nozzle, Fluid (Included in 79555 Kit)	
4	79001-09	O-Ring, Solvent Proof	1
5	74963-05	Standard Air Spray Restrictor, Black, Vector	1
	74963-06	Trans-Tech. Air Spray Restrictor, Green(Included in 79555 Kit)	

79555 TRANS-TECH. CONVERSION KITS AVAILABLE		
Kit Part No.	Fluid Nozzle Part No.	Description
79555-244	79552-244	1.4mm (.055") Acetal
79555-245	79552-245	1.8mm (.070") Acetal
79555-247	79552-247	0.7mm (.028") Acetal
79555-344	79552-344	1.4mm (.055") Peek
79555-345	79552-345	1.8mm (.070") Peek
79555-347	79552-347	0.7mm (.028") Peek

All Kits Include: 79374-122 Air Cap, 74963-06 Restrictor (green), and chosen Fluid Nozzle.

Kit 79555 replaces parts:

- 74963-05 Restrictor
- 79377-45 Fluid Nozzle
- 79374-65 Air Cap

NOTE: For additional information on solvent Viscosities and Conversion, refer to Technical Manual IL-307 @ www.ransburg.com.

ACCESSORIES FOR ECON FLUSH BOX COMPATIBILITY (OPTIONAL)	
Part No.	Description
77582-00	Nozzle Drain, Flush Box
77581-00	REA90 to REA70 Adapter, Flush Box

VECTOR CASCADE APPLICATORS RECOMMENDED SPARE PARTS		
Part #	Description	Qty
10051-05	Cup Seal, Spring Loaded	2
17130-00	Spring, Return	2
19749-00	Applicator Wrench	Accessory
3587-02	Nut and Ferrule	2
3587-03	Nut and Ferrule	2
59972-00	Dielectric Grease	Accessory
70430-01	Electrode High Flex	4
75326-00	Barret Retaining Ring	3
78626-00	Seal Cartridge	4
78627-04	Shaft Assembly, 2-Piece Needle, R90	2
78627-05	Shaft Assembly, 2-Piece Needle, R70	2
78628-11	Needle Shaft Assembly R90, Standard Packing	1
78628-12	Needle Shaft Assembly R70, Standard Packing	1
79629-00	2k Fluid Seal Repair Kit	1
79001-06	O-Ring, Solvent Proof	2
79001-07	O-Ring, Solvent Proof	4
79001-08	O-Ring, Solvent Proof	4
79001-09	O-Ring, Solvent Proof	6
79001-16	O-Ring, Solvent Proof	6
79001-31	O-Ring, Solvent Proof	2
79310-00	Air Valve Assembly	2
79322-00	Applicator Hook	1
79325-02	Trigger, 2-Finger	1
79338-01	Low Voltage Cable, 1m	Accessory
79338-10	Low Voltage Cable, 10m	1
79338-15	Low Voltage Cable, 15m	Accessory
79373-00	Barrel Retaining Nut	1
79374-65	Air Cap, V65	3
79374-98	Air Cap, V98	1
79377-44	Fluid Nozzle, 1.4mm/.055"	3
79377-45	Fluid Nozzle, 1.8mm/.070"	3
79378-00	Gasket, Barrel	2
79379-00	Air Cap Retaining Ring	2
79385-00	Nut Connector Hose	2
79438-00	Hose/Cable Support Bracket	1
79445-10	Fan Air Adjustment Assembly	2
79450-00	Trigger Stop Assembly	1
79454-00	Trigger Retaining Screws	4
79460-03	Plug Assembly	1
79468-00	Barrel, R90 Cascade	1
79468-00	Barrel, R70 Cascade	1
79471-01	Rear Cover W/Switch	1
79479-00	Applicator Hook Seal	1
79529-00-K5	Applicator Covers	Accessory
79560-00	Trigger Stop Assembly	1
79599-01	Needle Shaft Assembly, R90, 2k Packings	1
79599-02	Needle Shaft Assembly, R70, 2k Packings	1

(Continued On Next Page)

VECTOR CASCADE APPLICATORS RECOMMENDED SPARE PARTS (Cont.)		
Part #	Description	Qty
9704-16	Fluid Tube R70 Standard	1
	Fluid Tube R90 Standard	2 Ft.
A11745-00-K5	Cable Boot	Accessory
EMF-202-05	Ferrule, Back	2
EMF-203-05	Ferrule, Front	2
LSOR0005-17	O-Ring, PTFE Encapsulated	6
Power Supply Components		
79390-20	PC Board R70 Cascade	1
79390-22	PC Board R90 Cascade	1

WARRANTY POLICIES

LIMITED WARRANTY

Ransburg will replace or repair without charge any part and/or equipment that fails within the specified time (see below) because of faulty workmanship or material, provided that the equipment has been used and maintained in accordance with Ransburg's written safety and operating instructions, and has been used under normal operating conditions. Normal wear items are excluded.

THE USE OF OTHER THAN RANSBURG APPROVED PARTS VOID ALL WARRANTIES.

SPARE PARTS: One hundred and eighty (180) days from date of purchase, except for rebuilt parts (any part number ending in "R") for which the warranty period is ninety (90) days.

EQUIPMENT: When purchased as a complete unit, (i.e., guns, power supplies, control units, etc.), is one (1) year from date of purchase. **WRAPPING THE APPLICATOR, ASSOCIATED VALVES AND TUBING, AND SUPPORTING HARDWARE IN PLASTIC, SHRINK-WRAP, OR ANY OTHER NON-APPROVED COVERING, WILL VOID THIS WARRANTY.**

RANSBURG'S ONLY OBLIGATION UNDER THIS WARRANTY IS TO REPLACE PARTS THAT HAVE FAILED BECAUSE OF FAULTY WORKMANSHIP OR MATERIALS. THERE ARE NO IMPLIED WARRANTIES NOR WARRANTIES OF EITHER MERCHANTABILITY OR FITNESS FOR A PARTICULAR PURPOSE. RANSBURG ASSUMES NO LIABILITY FOR INJURY, DAMAGE TO PROPERTY OR FOR CONSEQUENTIAL DAMAGES FOR LOSS OF GOODWILL OR PRODUCTION OR INCOME, WHICH RESULT FROM USE OR MISUSE OF THE EQUIPMENT BY PURCHASER OR OTHERS.

EXCLUSIONS:

If, in Ransburg's opinion the warranty item in question, or other items damaged by this part was improperly installed, operated or maintained, Ransburg will assume no responsibility for repair or replacement of the item or items. The purchaser, therefore, will assume all responsibility for any cost of repair or replacement and service related costs if applicable.

MANUAL CHANGE SUMMARY

This manual was published to supersede Service Manual **AH-06-01.12**
Vector Solo Applicators to make the following changes:

1. Revised Pg 43 packing nut adjustment instruction (item 18).

Manufacturing

1910 North Wayne Street
Angola, Indiana 46703-9100
Telephone: 260-665-8800
Fax: 260-665-8516

Technical Service — Assistance

320 Philips Ave.
Toledo, Ohio 43612-1493
Telephone (toll free): 800-233-3366
Fax: 419-470-2233

Technical Support Representative will direct you to the appropriate telephone number for ordering Spare Parts.