

RANSBURG VECTOR™ AND SOLO™ APPLICATORS

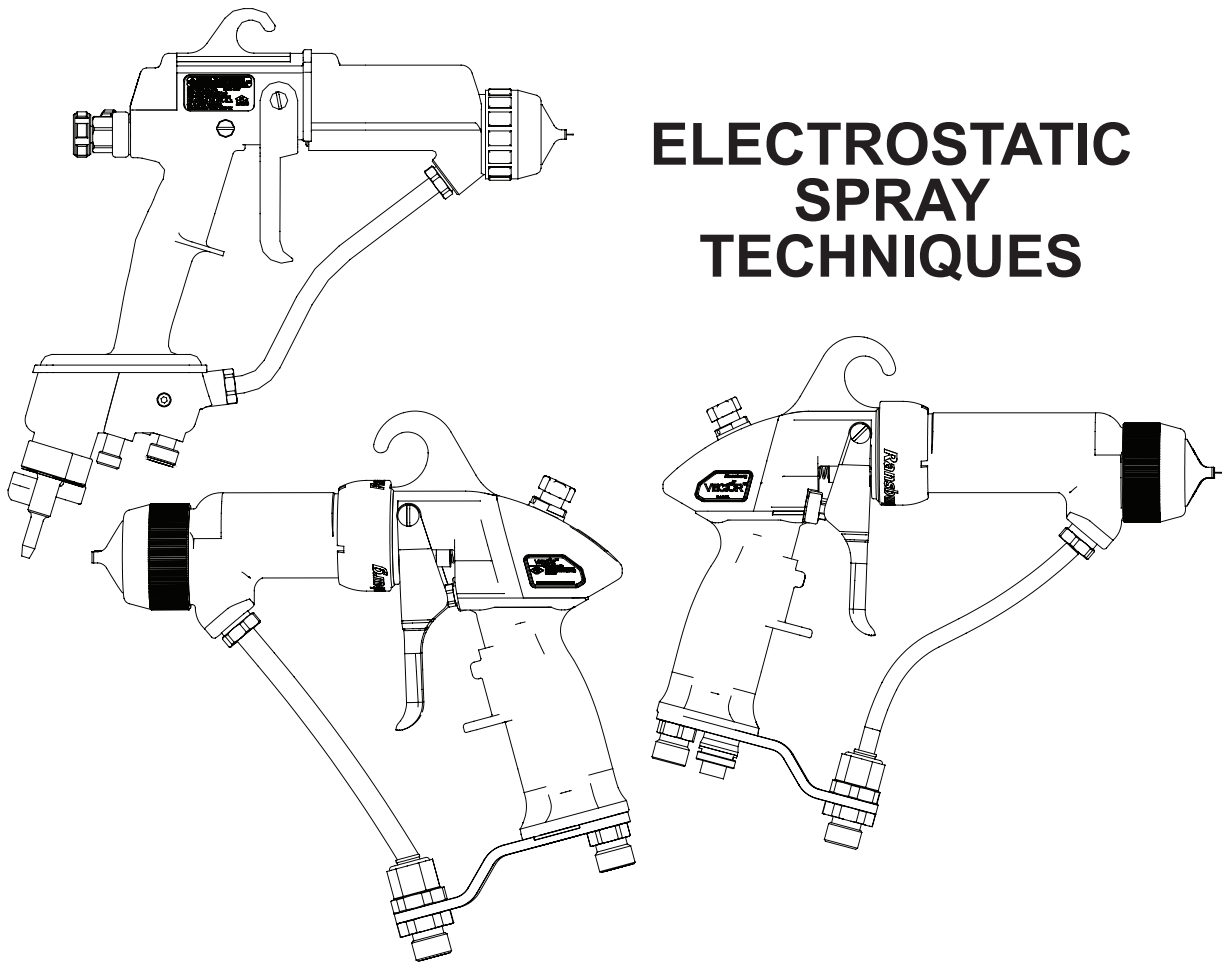

ELECTROSTATIC SPRAY TECHNIQUES

IMPORTANT: Before using this equipment, carefully read **SAFETY PRECAUTIONS**, starting on page 1, and all instructions in this manual. Keep this Technical Manual for future reference.

Technical Manual Price: €15.00 Euro)
\$20.00 (U.S.)

NOTE: This manual has been changed from **IL-246-B** to revision **IL-246-C**. Reasons for this change are noted under “Manual Change Summary” inside the back cover of this manual.

CONTENTS

	PAGE
VECTOR AND VECTOR SOLO APPLICATOR SPRAY TECHNIQUES:	1-11
USE THE RIGHT TECHNIQUE.....	1
FAN CONTROL.....	2
PATTERN.....	2
FLAT SURFACES.....	3
HORIZONTAL PASSES.....	3
VERTICAL PASSES.....	3
APPLICATOR TO TARGET DISTANCE.....	4
OVERLAP.....	5
TRIGGERING.....	5
LARGE OBJECTS.....	6
TUBULAR WORK.....	7
RECESSED AREAS.....	8
SUMMARY.....	9-10
SAFETY REQUIREMENTS.....	11

Before operating, maintaining, or servicing any Ransburg electrostatic coating system, read and understand all of the technical and safety literature provided with Ransburg products. If you do not have the manuals and safety literature for your Ransburg system, contact your Ransburg representative.

USE THE RIGHT TECHNIQUES

Vector/Solo (Electrostatic) Applicators

Savings of 25% to 50% in paint is possible when you replace conventional air spray with Ransburg Electrostatic Applicators. You finish curved and recessed surfaces uniformly in fewer passes, because combined air and electrostatic forces literally follow the shape of the work surface. Bounce losses from work are reduced by the electrostatic attraction, when proper techniques are used.

The following describes basic electrostatic spray techniques. Depending on the type of work being sprayed, it may be necessary to change the technique slightly.

FAN CONTROL

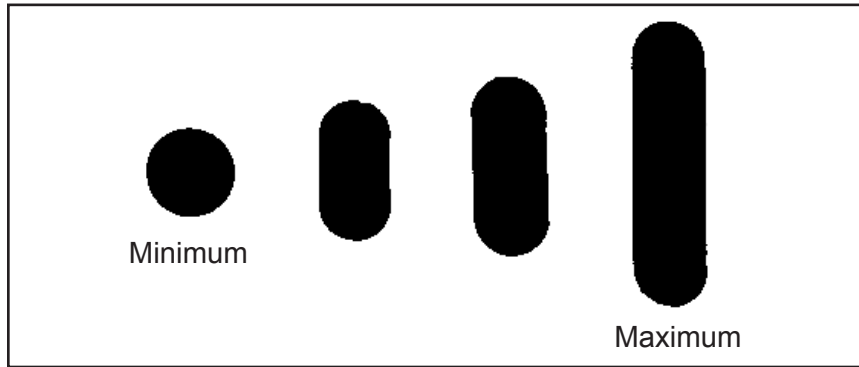

The size of the object being coated is the determining factor in adjusting the fan pattern; the larger the object, the larger the required fan pattern. Fan control of the Ransburg Vector/Solo applicators is accomplished by rotating the adjusting knob located at the rear of the applicator. Fan width can be set for approximately a 3-inch width (minimum) to approximately a 14-inch (maximum). Fan widths and overall pattern appearances are illustrated.

PATTERN

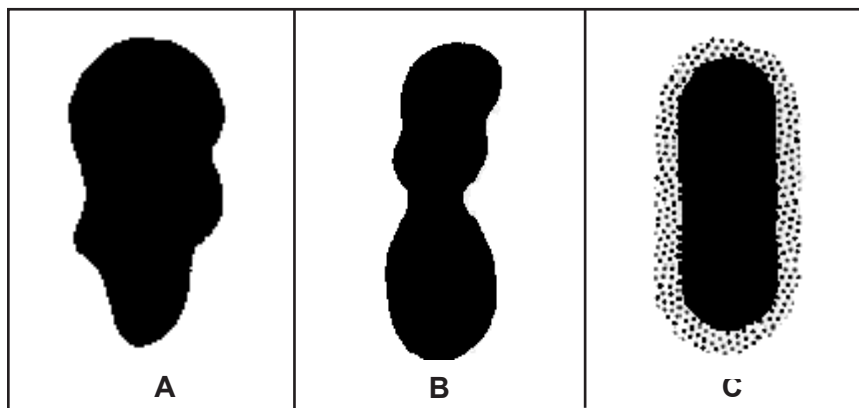

POOR PATTERN
 Dirty, worn, or
 damaged nozzle.
 Clean or replace.

SPLIT PATTERN
 Fan too wide - narrow
 adjustment slightly.

GOOD PATTERN

NOTE

► The degree of atomization is dependent on the viscosity of the paint formulation, the applied air pressure, and nozzle selection.

FLAT SURFACES

One of the most prevalent of "bad" spray painting habits is the one where the operator holds his arm steady and swings his wrist back and forth. This is a hard habit to break, it gives the illusion of adding speed to the coating operation, when in reality, it is slower and much more inefficient. Spray painting in this fashion results in light films on both sides, excessive film at center, and increased overspray with excessive "bounce-back."

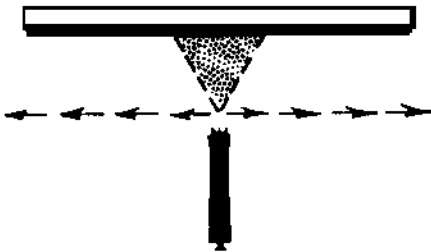
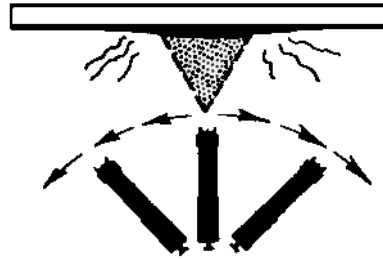

HORIZONTAL PASSES

The spray applicator should be maintained in a position at right angles to the object and should be moved in a path parallel to the object.

VERTICAL PASSES

There may be instances where it is more practical to coat an object using vertical passes rather than horizontal. First, rotate the nozzle to shift the fan pattern, then holding the applicator at right angles to the object, move the applicator in a straight vertical path as illustrated.

APPLICATOR TO TARGET DISTANCE

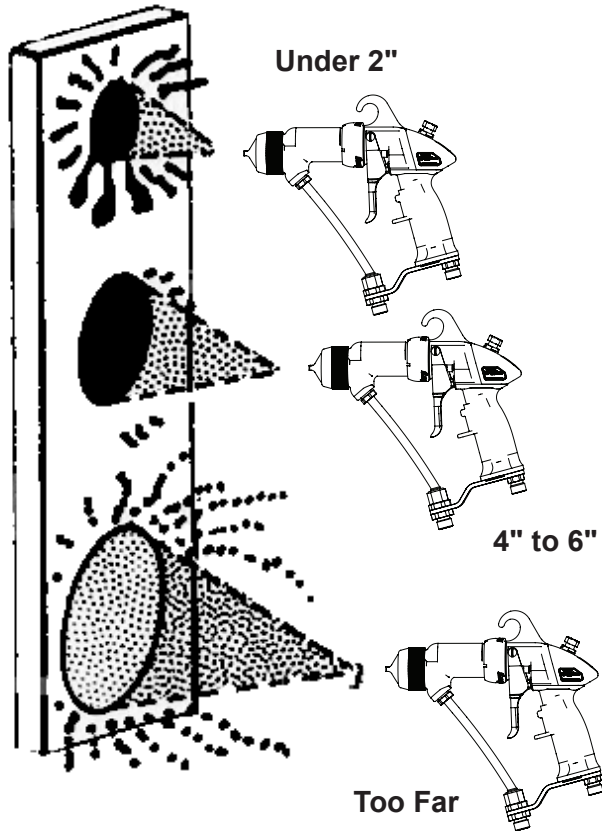

The distance between the applicator and the target influences the appearance of the final finish coating of the object. If the applicator is held too close (under 4-inches), runs and sags with the excessive bounce-back can occur. If the applicator is held too far from the object, the electrostatic attraction is decreased. Normally, the **best spacing** between applicator and target is in the **4 to 12-inch area**. However, this distance can vary with extremely high delivery systems. Maximum target distance should not exceed 12-inches.

 CAUTION
<p>► The object being coated is maintained at ground potential, the spray applicator operator is also grounded, therefore, the operator has as much attraction for the electrostatic paint as the object. To prevent "wrapback" always keep the applicator closer to the target than it is to you.</p>

OVERLAP

For best hiding and uniformity of film thickness, stroke overlap should be approximately 50%. There should be some overlap at the top and bottom of the part to increase edge coverage. Overlap requirements can vary widely with different paint formulations and different compositions of objects being coated. Individual spray coating operational experience should provide the guidelines for efficiency in this instance.

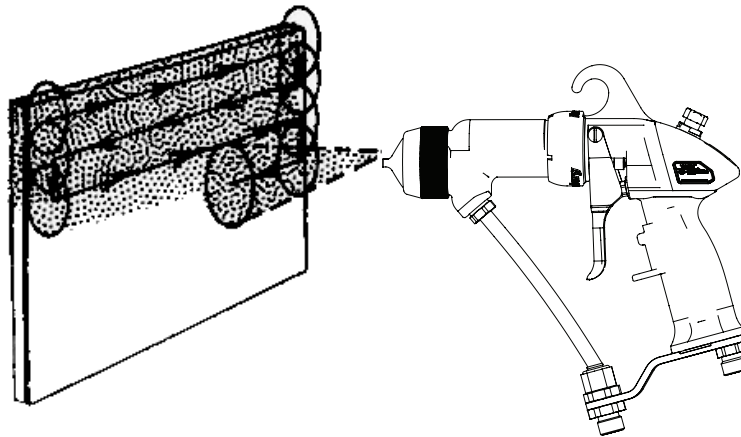

TRIGGERING

Applicator triggering (ON/OFF) depends largely on the desired results; the amount of wraparound required, edge coating, etc. If front and back of the object are being coated, proper applicator technique can effect edge coating (in some instances) without making a specific pass for this purpose. Examples of different trigger times and the results that can be expected are illustrated.

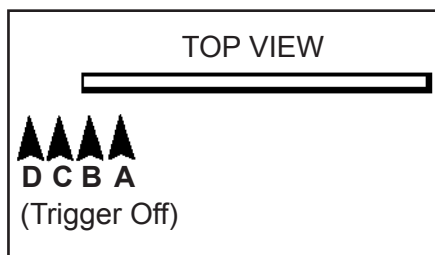

- A. Little or no wrap - incomplete coverage
- B. Fair - some wrap
- C. Good wrap (Triggered 2" to 3" past edge)
- D. Too much overstroke may produce heavy edges and produce more overspray.

NOTE

► If front and back are both sprayed, there may be enough wrap using Technique B or C to coat a small edge or flange. If wide flanges are to be coated, this may require individual coating of edges before the flat surfaces are sprayed.

LARGE OBJECTS

Blending

If the size of the object is greater than the spray applicator operator can reach, it should be coated in segments, the size of each segment being the length the spray applicator operator can comfortably span. Each segment should be blended with the adjacent segment using "feathering" or "over-lapping" strokes. A slight angle of the applicator improves the results of the "blending" pass.

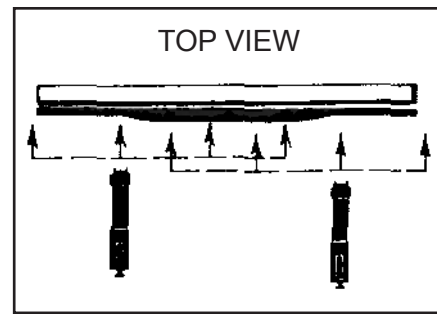
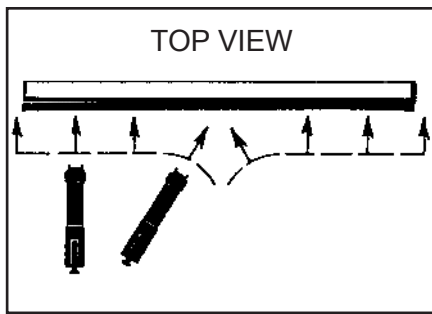

CAUTION

- ▶ Too much overlap can result in runs and sags or excessive film, where segments blend together.

TUBULAR WORK

Tubular parts or objects up to approximately 2-1/2" diameter can be coated successfully from one side, utilizing wraparound characteristics and proper techniques.

NOTE

- Avoid applicator to target distances of over 12-inches, excessive applicator to target distances will result in wrapback.

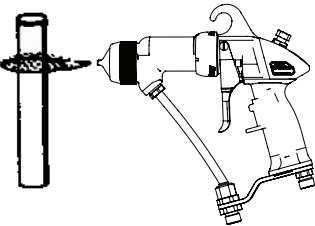
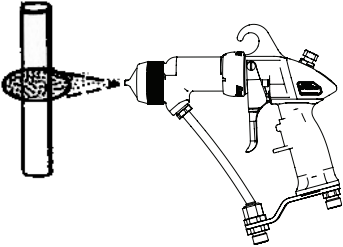
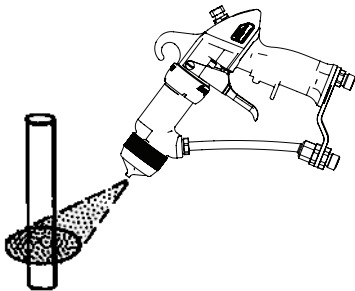
 <p>Adjust the fan for a pattern width slightly wider than the object. This allows some coating material to start around the sides of the object.</p>	 <p>Increase the applicator to target distance to approximately 10-12-inches. This will decrease the speed of the paint particles in the vicinity of the target.</p>	 <p>Hold the applicator at an angle of 30° to 45° to the object. This will direct paint more to target area.</p>
---	--	--

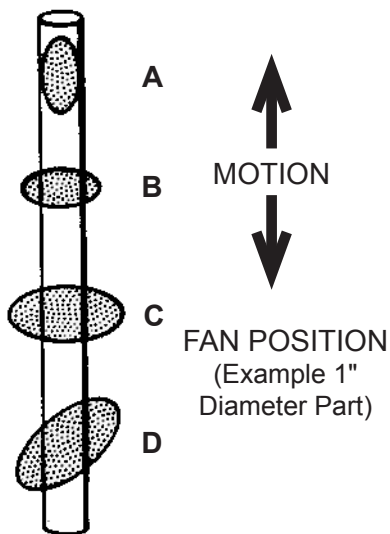

- A. Wrong fan position - little wrap. Heavy film on front surface, possible sags.
- B. Correct fan position - better wrap. More accurately controlled film. Normally fan pattern should be slightly wider than parts being sprayed.
- C. Correct fan position but excessively wide fan may produce more overspray if used in this position.
- D. A wide fan tilted at an angle may also work well. (Wide fans have slower forward velocity.)

SUGGESTION: Small tubes may be racked in groups to simulate larger targets. This allows the use of wider fans and may help improve efficiency.

RECESSED AREAS

Do not depend on electrostatic attraction alone for coating recessed areas, remember, the more exposed areas of the object have a stronger attraction for charged paint formulations than the recessed areas, therefore, the electrostatically charged paint particles will take the path of least resistance, and tend to build excessively on the more exposed areas.

The best and most efficient technique is to coat the recessed areas first, utilizing air pressure to drive

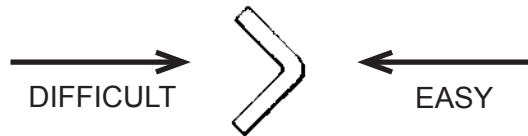

the paint into difficult areas or by narrowing fan width to effectively increase delivery rate per inch of pattern width. Then paint the more readily accessible areas, the electrostatic process with its "wrap-around" and "opposite attraction" characteristics will probably have already partly coated these areas.

A. Voltage by itself will not pull paint into deep recesses, but instead, paint will be attracted to more exposed edges.

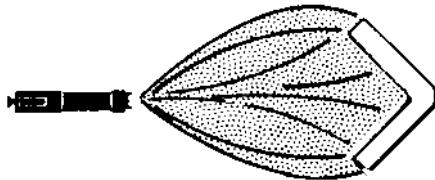

B. Solution: Move in closer and use the advantages of air atomization to drive paint into recesses.

NOTE: Narrower fan may also be helpful.

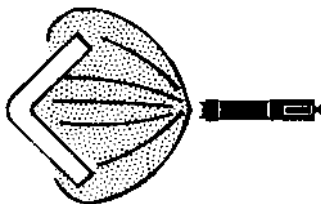

C. Doing the outside of the part first puts little paint on the inside. If we now coat the inside, we will be double coating the edges and possibly overload them.

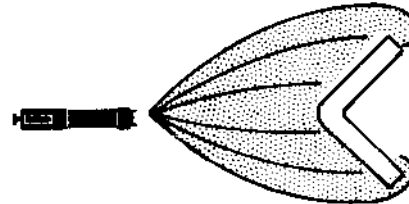

D. In this example, we coat the difficult area first. We may then find that there was enough wrap around from overspray to coat much of the remaining areas.

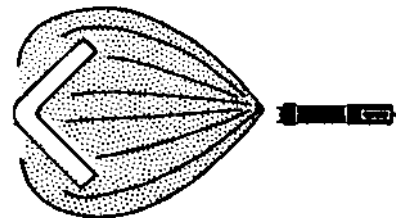

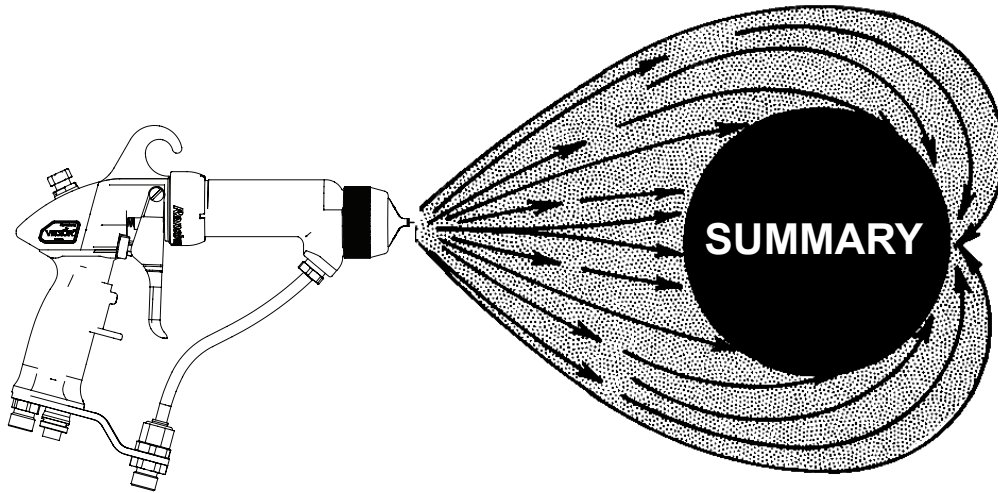

1



Adjust fan pattern in accordance with size of object to be coated.

2

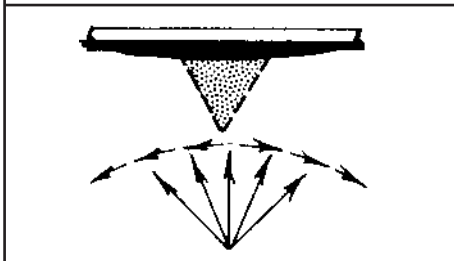

Never swing spray applicator in an arc, hold applicator steady in a position at right angles to the object and move applicator in a straight path parallel to object.

3

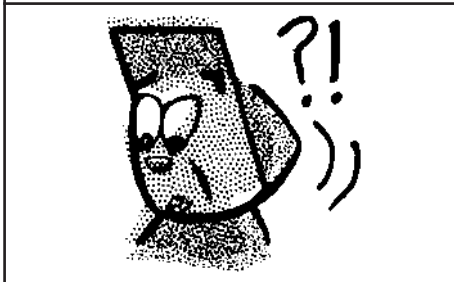

Be sure applicator is held closer to object being coated than to the operator.

4

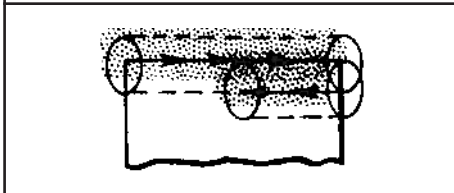

Stroke overlap of approximately 50% normally produces adequate film thickness uniformity.

5

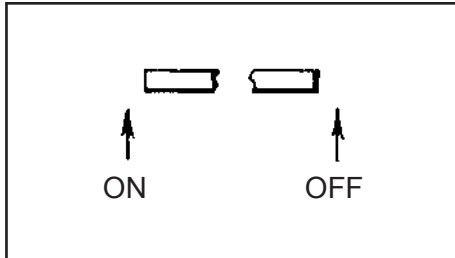

6

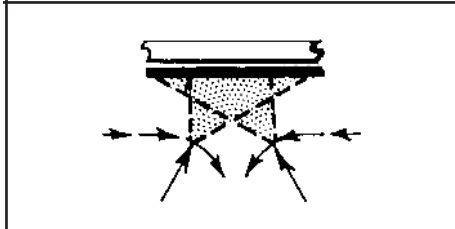

7

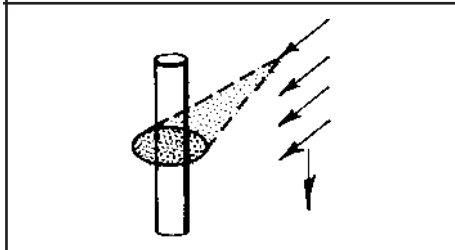

8

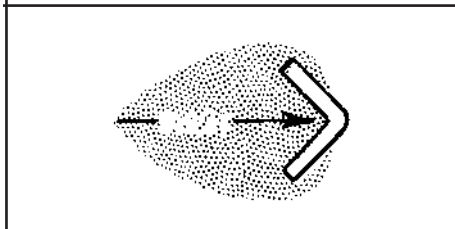

For most economical and efficient coating, trigger applicator "ON" just before leading edge of object, trigger applicator "OFF" just after trailing edge of target. For best wraparound technique, trigger applicator "ON" 3-inches before, and "OFF" 3-inches after edges of target.

When painting large objects a section at a time, use "feather" stroke for blending sections together. Avoid excessive overlap to prevent runs and sags with excessive film thickness.

Tubular component coating; adjust fan width for a pattern slightly wider than the object, hold applicator 10 to 12-inches from object at an angle of 30 to 45- inches. Move applicator straight in a parallel path with the object.

Paint "hard to reach" areas first, let wraparound and electrostatic attraction get the "easy" areas for you.

SAFETY REQUIREMENTS

Personnel

- Operators must **NOT** wear gloves that insulate them from the applicator handle.
- ALL personnel in the spraying area **MUST** wear non-insulating shoes or alternative grounding devices so they will be grounded through the conductive floor. (See Ransburg "Personnel Grounding" Safety Bulletin.)
- Personnel entering a waterborne paint isolation enclosure **MUST** be sure that the system and the Warning Light are **OFF!** The grounding hook must be attached to the paint supply **BEFORE** contact, especially during the addition of fluid! The gate **MUST** be closed and the interlocks functioning during use. (See the appropriate Ransburg equipment manual.)
- The operator **MUST** turn the power supply **OFF** before cleaning or servicing the equipment.
- **NEVER** immerse an applicator in any liquid.
- Exhaust fans **MUST** be **ON** during spraying.

Environment and Equipment

- The spray booth (including its floor), paint reservoir (except waterborne), and conveyor **MUST** be grounded.
- An adequate, grounded, protective enclosure that will assure safe isolation from personnel must surround the supply of waterborne paints. (See OSHA Standard 1910.107 (h) (10).)
- The spray target and all supporting holders, hooks, and conveyors **MUST** be grounded to the supporting structure. All support devices **MUST** be free of accumulated coating material.

- All conductive objects in the spraying area **MUST** be removed or grounded.
- A pressure **EXPLOSION** may occur if **HALOGENATED HYDROCARBON** solvents are used in **PRESSURIZABLE** fluid systems having **ALUMINUM** or **GALVANIZED** parts. (See Ransburg "Danger - Explosion Hazard" and "Halogenated Hydrocarbon" Safety bulletins.)
- The high voltage power supply **MUST** be grounded and located outside of the Hazard Area. (See the appropriate Ransburg equipment manual.)
- Appropriate, functioning fire extinguishing equipment **MUST** be provided.
- Good housekeeping is essential to safe operation. Cleanup and maintenance schedules should be established by the user. Maintenance and safety cards should be posted in clear view of the operator.
- All flammable liquids **MUST** be in approved, grounded safety containers. Not more than one gallon should be in any container and the total amount in the spray area should be no more than the minimum required for the operation.
- All applicators **MUST** be maintained within proper operating limits. (See the appropriate Ransburg equipment manual for short circuit current tests.)

MANUAL CHANGE SUMMARY

This manual was published to supercede Technical Manual **IL-246-B, Ransburg Vector Applicators Electro-Air Spray Techniques**, to make the following change:

1. Service literature was reformatted. Made available electronically.
2. Added "Technical Manual Price: €15.00 (Euro)" to the "Front and Back Covers".
3. Added "Vector Applicators" to the "Spray Techniques".
4. New "Applicator Figures" throughout the service literature.
5. Added "www.ransburg.com" to "Contact Information" on the back cover.

Technical Manual Price: €15.00 Euro)
\$20.00 (U.S.)

Manufacturing

1910 North Wayne Street
Angola, Indiana 46703-9100
Telephone: 260/665-8800
Fax: 260/665-8516

Technical/Service Assistance

Telephone: 800/ 233-3366
Fax: 419/ 470-2071
www.ransburg.com

Technical Support Representative will direct you to the appropriate telephone number for ordering Spare Parts.