

TCM-65K (2") // 2" 600lb ANSI Flanges // Field Mount Electronics

Unit Mass: 81 lbs (approx)

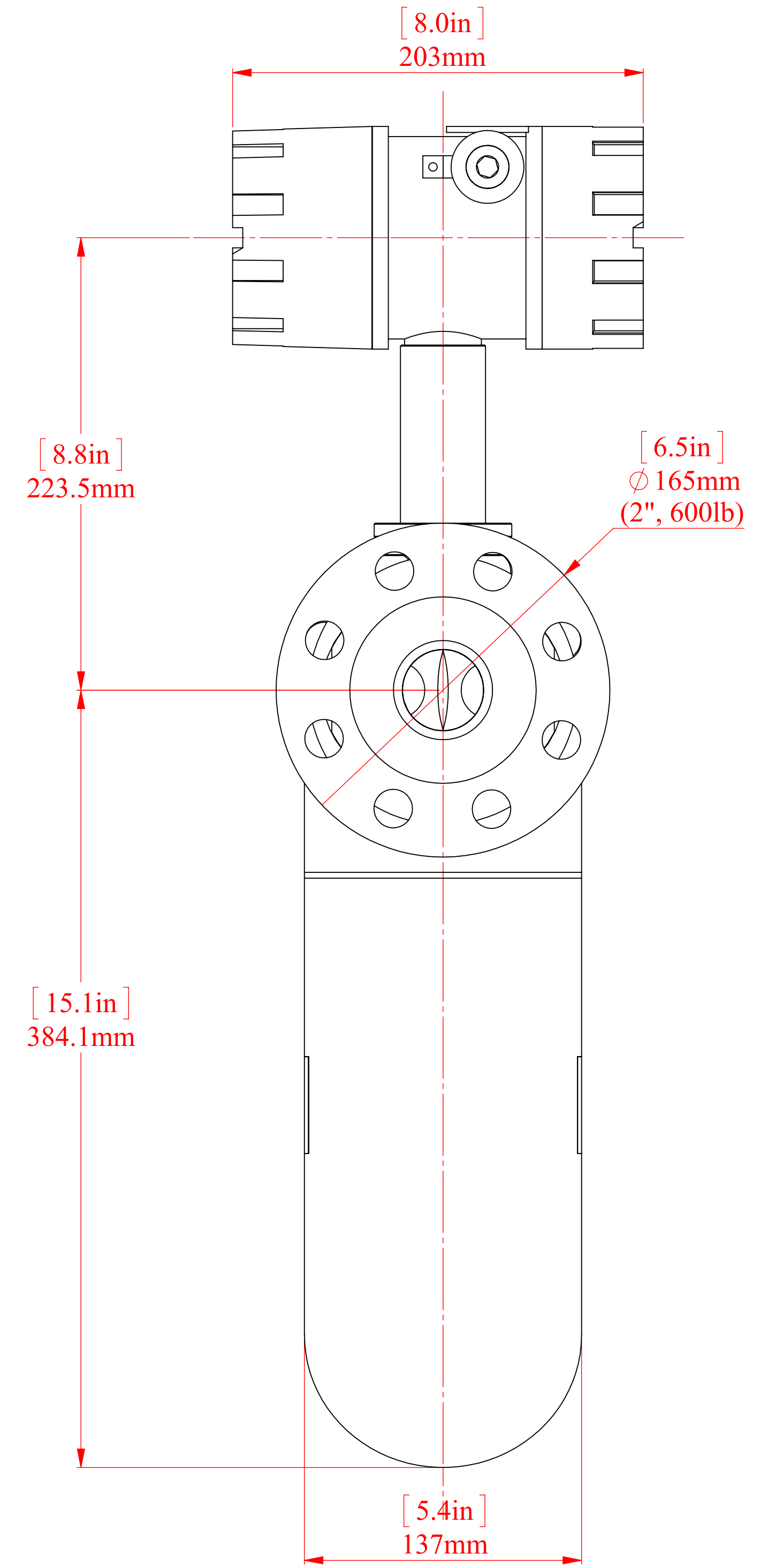
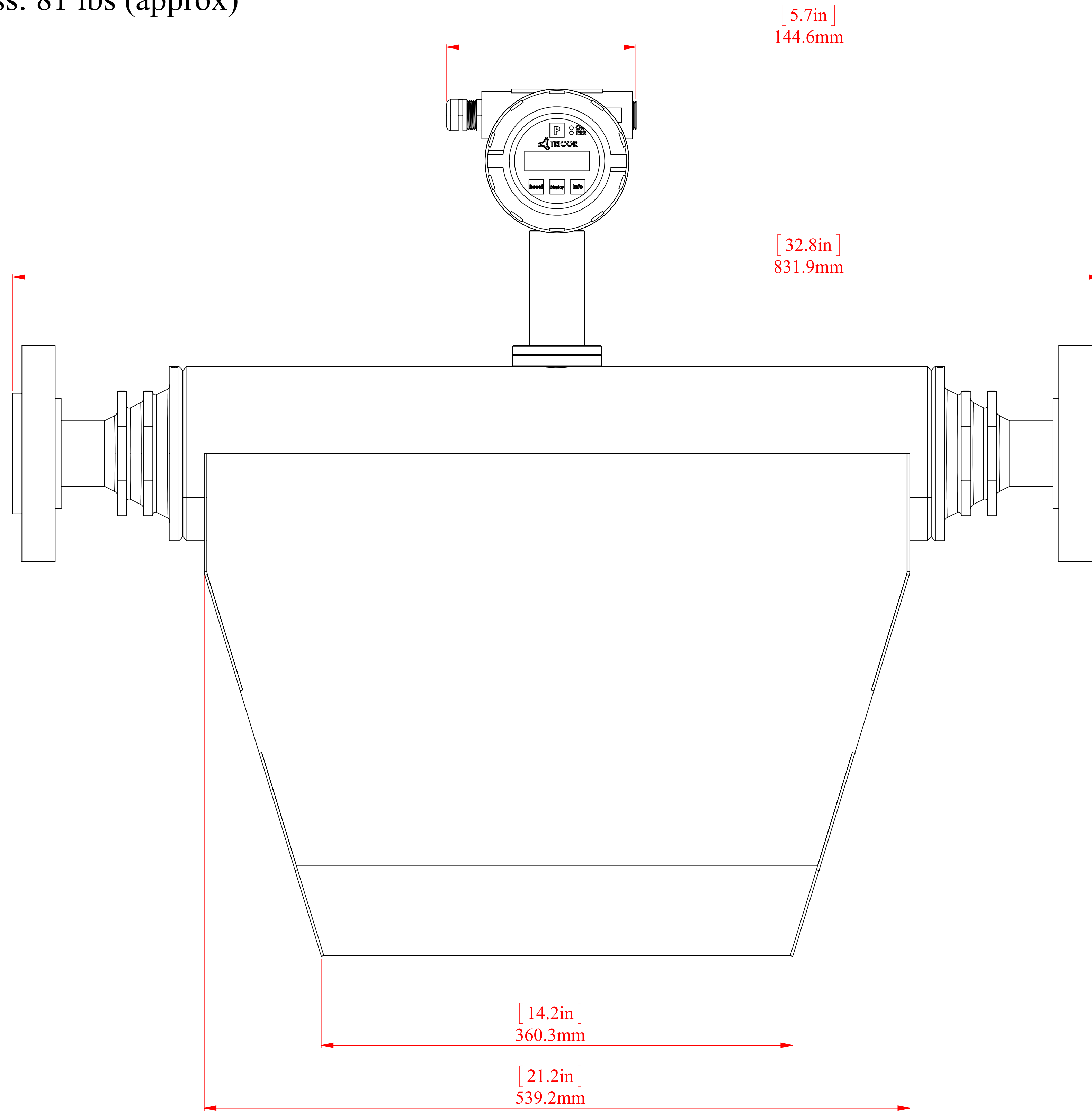

REV.	DESCRIPTION	DATE	APPROVED
A	INITIAL DRAWING RELEASE	9/16/2011	SAH
	REVISIONS		

AW-LAKE COMPANY USE ONLY
PURCHASED PART

THIS PRINT, INCLUDING THE INFORMATION CONTAINED IN IT IS THE PROPERTY OF AW-LAKE COMPANY. IT IS CONSIDERED PROPRIETARY IN NATURE AND MAY NOT BE USED OR DISCLOSED OUTSIDE OF AW-LAKE COMPANY, EXCEPT UNDER PRIOR WRITTEN AGREEMENT. ANY MODIFICATIONS MADE TO OR COMMENTS WRITTEN ON THIS DRAWING BY UNAUTHORIZED PERSONNEL WILL VOID THIS DRAWING. ALL DIMENSIONS SHOWN ARE SUBJECT TO CHANGE WITHOUT NOTICE.

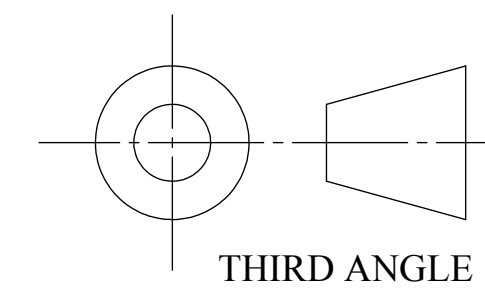

TOLERANCES UNLESS NOTED
MERIC

.XXX +/- .013
.XX +/- .025
.X +/- .25

FRAC. +/- 1/64
ANG. +/- 0.1 DEG
SURFACE FINISH: 64 MAX

PROJECT NAME: TRICOR, TCM-65K (2")	
PART DESCRIPTION: 2", 600LB ANSI + FIELD MOUNT	
MATERIAL: NA	
FINISH: NA	
HARDENING: NA	
DRAWING NUMBER: TCM-65K-AP-%%-C-%%	
PART NUMBER: TCM-65K	REV: A
DRAWN BY: S. HONSBERGER	DATE: 09/16/11
PAGE: 1 OF 2	SCALE: 1:2



AW-LAKE COMPANY
A TASI GROUP COMPANY

8809 INDUSTRIAL DR.
FRANKSVILLE, WI
53126
TEL. # (262) 884-9800
FAX. # (262) 884-9810