

DOCUMENTATION

PUMP 15-C50

AIRMIX[®]

Manual : 582.093.110-UK - 2006

Date: 25/06/20

Supersede : 02/10/19

Modif.: Update

TRANSLATION FROM THE ORIGINAL MANUAL

IMPORTANT : Before assembly and start-up, please read and clearly understand all the documents relating to this equipment (professional use only).

THE PICTURES AND DRAWINGS ARE NON CONTRACTUAL. WE RESERVE THE RIGHT TO MAKE CHANGES WITHOUT PRIOR NOTICE.

SAMES KREMLIN SAS
13, chemin de Malacher
38 240 - MEYLAN - France
 : 33 (0)4 76 41 60 60

www.sames-kremlin.com



<p align="center">FR</p> <p>Pour une utilisation sûre, il est de votre responsabilité de :</p> <ul style="list-style-type: none"> • Lire attentivement tous les documents contenus dans le CD joint avant la mise en service de l'équipement, • D'installer, d'utiliser, d'entretenir et de réparer l'équipement conformément aux préconisations de SAMES KREMLIN ainsi qu'aux réglementations nationales et/ou locales, • Vous assurez que les utilisateurs de cet équipement ont été formés, ont parfaitement compris les règles de sécurité et qu'ils les appliquent. 	<p align="center">UK</p> <p>To ensure safe use of the machinery, it is your responsibility to:</p> <ul style="list-style-type: none"> • Carefully read all documents contained on the enclosed CD before putting the machinery into service, • Install, use, maintain and repair the machinery in accordance with SAMES KREMLIN's recommendations and national and/or local regulations, • Make sure that the users of the machinery have received proper training and that they have perfectly understood the safety rules and apply them. 	<p align="center">DE</p> <p>Eine sichere Nutzung setzt voraus, dass Sie :</p> <ul style="list-style-type: none"> • alle in der CD enthaltenen Dokumente vor der Inbetriebnahme der Anlage aufmerksam lesen, • die Anlage im Einklang mit den Empfehlungen von SAMES KREMLIN sowie mit den nationalen und/oder lokalen Bestimmungen installieren, verwenden, warten und reparieren, • sich vergewissern, dass die Nutzer dieser Anlage angemessen geschult wurden, die Sicherheitsbestimmungen verstanden haben und sie anwenden.
<p align="center">ES</p> <p>Para una utilización segura, será de su responsabilidad:</p> <ul style="list-style-type: none"> • leer atentamente todos los documentos que se incluyen en el CD adjunto antes de la puesta en servicio del equipo, • instalar, utilizar, efectuar el mantenimiento y reparar el equipo con arreglo a las recomendaciones de SAMES KREMLIN y a la normativa nacional y/o local, • cerciorarse de que los usuarios de este equipo han recibido la formación necesaria, han entendido perfectamente las normas de seguridad y las aplican. 	<p align="center">IT</p> <p>Per un uso sicuro, vi invitiamo a:</p> <ul style="list-style-type: none"> • leggere attentamente tutta la documentazione contenuta nel CD allegato prima della messa in funzione dell'apparecchio, • installare, utilizzare, mantenere e riparare l'apparecchio rispettando le raccomandazioni di SAMES KREMLIN, nonché le normative nazionali e/o locali, • accertarvi che gli utilizzatori dell'apparecchio abbiano ricevuto adeguata formazione, abbiano perfettamente compreso le regole di sicurezza e le applichino. 	<p align="center">PT</p> <p>Para uma utilização segura, é da sua responsabilidade:</p> <ul style="list-style-type: none"> • Ler atentamente todos os documentos incluídos no CD em anexo antes de pôr o equipamento em funcionamento, • Proceder à instalação, utilização, manutenção e reparação do equipamento de acordo com as preconizações de SAMES KREMLIN, bem como com outros regulamentos nacionais e/ou locais aplicáveis, • Assegurar-se que os utilizadores do equipamento foram devidamente capacitados, compreenderam perfeitamente e aplicam as devidas regras de segurança.
<p align="center">NL</p> <p>Voor een veilig gebruik dient u:</p> <ul style="list-style-type: none"> • alle document op de bijgevoegde cd aandachtig te lezen alvorens het apparaat in werking te stellen, • het apparaat te installeren, gebruiken, onderhouden en repareren volgens de door SAMES KREMLIN gegeven aanbevelingen en overeenkomstig de nationale en/of plaatselijke reglementeringen, • zeker te stellen dat de gebruikers van dit apparaat zijn opgeleid, de veiligheidsregels perfect hebben begrepen en dat zij die ook toepassen. 	<p align="center">SE</p> <p>För en säker användning av utrustningen ansvarar ni för följande:</p> <ul style="list-style-type: none"> • Läs noga samtliga dokument som finns på den medföljande cd-skivan innan utrustningen tas i drift. • Installera, använd, underhåll och reparera utrustningen enligt anvisningarna från SAMES KREMLIN och enligt nationella och/eller lokala bestämmelser. • Försäkra er om att användare av denna utrustning erhållit utbildning, till fullo förstått säkerhetsföreskrifterna och tillämpar dem. 	<p align="center">FI</p> <p>Käytön turvallisuuden varmistamiseksi velvollisuutesi on:</p> <ul style="list-style-type: none"> • Lukea huolella kaikki CD:llä olevat asiakirjat ennen laitteiston käyttöönottoa, • Noudattaa laitteiston asennuksessa, käytössä, kunnossapidossa ja huollossa SAMES KREMLIN in suosituksia sekä kansallisia ja/tai paikallisia määräyksiä, • Varmistaa, että laitteiston käyttäjät ovat koulutettuja ja ymmärtävät täysin turvallisuusmääräykset ja miten niitä sovelletaan.
<p align="center">PL</p> <p>Dla zapewnienia bezpiecznego użytkowania na użytkownika spoczywa obowiązek:</p> <ul style="list-style-type: none"> • Uważnego zapoznania się ze wszystkimi dokumentami znajdującymi się na załączonej płycie CD przed pierwszym uruchomieniem urządzenia, • Instalowania, użytkowania, konserwacji i naprawy urządzenia zgodnie z zaleceniami firmy SAMES KREMLIN oraz z przepisami miejscowymi, • Upewnienia, że wszyscy przeszkoleni użytkownicy urządzenia zrozumieli zasady bezpieczeństwa i stosują się do nich. 	<p align="center">CS</p> <p>Pro bezpečné používání jste povinni:</p> <ul style="list-style-type: none"> • Před uvedením zařízení do provozu si pozorně přečíst veškeré dokumenty obsažené na příloženém CD, • Nainstalovat, používat, udržovat a opravovat zařízení v souladu s pokyny firmy SAMES KREMLIN a s národními a/nebo místními legislativními předpisy, • Ujistit se, že uživatelé tohoto zařízení byli vyškoleni, že dokonale pochopili bezpečnostní pravidla a že je dodržují. 	<p align="center">SL</p> <p>Za varno uporabo ste dolžni:</p> <ul style="list-style-type: none"> • natančno prebrati vse dokumente na CD pred zagonom stroja, • instalirati, uporabljati, vzdrževati in popravljati opremo po določilih SAMES KREMLIN in v skladu z veljavnimi nacionalnimi in/ali lokalnimi predpisi, • poskrbeti, da so uporabniki te opreme ustrezno usposobljeni, poznajo varnostne predpise in da jih upoštevajo.
<p align="center">SK</p> <p>V záujme bezpečného je vašou povinnosťou:</p> <ul style="list-style-type: none"> • pozorne si prečítať všetky dokumenty obsiahnuté na príloženom CD predtým, ako zariadenie uvediete do prevádzky, • nainštalovať, používať, udržiavať a opravovať zariadenie v súlade s odporúčaniami spoločnosti SAMES KREMLIN a národnými a/alebo miestnymi predpismi, • uistiť sa, že používatelia tohto zariadenia boli zaškolení, riadne porozumeli pravidlám bezpečnosti a používajú ich. 	<p align="center">HU</p> <p>A biztonságos használat érdekében az Ön felelőssége, hogy:</p> <ul style="list-style-type: none"> • a berendezés üzembe helyezése előtt figyelmesen elolvassa a mellékelt CD által tartalmazott összes dokumentumot, • a berendezést a SAMES KREMLIN ajánlásainak valamint a nemzeti és/vagy helyi szabályozásoknak megfelelően helyezze üzembe, használja, tartsa karban és javítsa, • megbizonyosodjon róla, hogy a berendezés felhasználói képzettek, tökéletesen megértették és alkalmazzák a biztonsági előírásokat. 	<p align="center">RO</p> <p>Pentru o utilizare sigură, este responsabilitatea dvs. să:</p> <ul style="list-style-type: none"> • Citiți cu atenție toate documentele de pe CD-ul anexat, înainte de punerea în funcțiune a echipamentului, • Instalați, utilizați, întrețineți și reparați echipamentul conform instrucțiunilor SAMES KREMLIN precum și reglementărilor naționale și/sau locale, • Vă asigurați că utilizatorii acestei echipament au fost instruiți, au înțeles perfect regulile de securitate și le aplică integral.

Declaration(s) de conformité au verso de ce document / Declaration(s) of conformity at the back of this document / Konformitätserklärung(en) auf der Rückseite dieser Unterlage / Declaración (es) de conformidad en el reverso de este documento / Dichiarazione/i di conformità sul retro del presente documento / Declaração(ões) de conformidade no verso do documento / Conformiteitsverklaring(en) op de keerzijde van dit document / Försäkran om överensstämmelse på omstående sida av detta dokument / Vaatimustenmukaisuusvakuutusket tämän asiakirjan kääntöpuolella / Deklaracja(e) zgodności na odwrocie dokumentu / Prohlášení o shodě se nachází/nacházejí na zadní straně tohoto dokumentu / Deklaracija(e) o skladnosti na hrbtni strani tega dokumenta / Vyhlášení/-a o zhode sa nachádzajú na zadnej strane dokumentu / A dokumentum hátlapján szereplő megfeleléségi nyilatkoz(ok) / Declarații de conformitate pe versoul acestui document



DECLARATION UE DE CONFORMITE
EU DECLARATION OF CONFORMITY
EU- KONFORMITÄTSEKTLÄRUNG
DECLARACIÓN UE DE CONFORMIDAD
DICHIARAZIONE DI CONFORMITÀ UE
DECLARAÇÃO UE DE CONFORMIDADE
EU-KONFORMITEITSVERKLARING
EU-FÖRSÄKRAN OM ÖVERENSSTÄMMELSE
EU- VAATIMUKSEN MUKAISUUSVAKUUTUS
DEKLARACJA ZGODNOŚCI UE
EU PROHLÁŠENÍ O SHODĚ
IZJAVA EU O SKLADNOSTI
VYHLÁSENIE O ZHODE
EU-MEGFELELŐSÉGI NYILATKOZAT
DECLARAȚIA DE CONFORMITATE UE

Le fabricant / The manufacturer / Der Hersteller / El fabricante / Il produttore / O fabricante / De fabrikant / Tillverkare / Valmistaja / Producent / Výrobce / Proizvajalec / Výrobca / Gyártó / Fabricantul:	SAMES KREMLIN SAS 13, chemin de Malacher 38 240 - MEYLAN - FRANCE Tél. : 33 (0)4 76 41 60 60
---	--

Déclare que le matériel désigné ci-après / Herewith declares that the equipment / erklårt hiermit, dass die / Declara que el material designado a continuación / Dichiaro che il materiale sottoindicato / Declara que o material a seguir designado / verklaart dat de hieronder aangeduide apparatuur / Kungör att den utrustning som anges här nedan / ilmoittaa, että alla mainitut laitteistot / Oświadcza, że wymienione poniżej urządzenia / Prohlašuje, že níže uvedené vybavení / Izjavlja, da je opisana oprema spodaj / Vyhlasuje, že zariadenie uvedené nižšie / Kijelenti, hogy a megjelölt anyag a továbbiakban / Declară că echipamentul precizat mai jos:

POMPES / PUMPS / PUMPEN / BOMBAS / POMPE / POMPEN / PUMPAR / PUMPUT / POMPY / НАСОСЫ

15-C50

Est conforme à la législation d'harmonisation de l'Union applicable suivante / Is in conformity with the relevant Union harmonisation legislation / Erfüllt die einschlägigen Harmonisierungsrechtsvorschriften der Union / es conforme con la legislación de armonización pertinente de la Unión / è conforme alla pertinente normativa di armonizzazione dell'Unione / in overeenstemming met de desbetteffende harmonisatiewetgeving van de Unie / med den relevanta harmoniserade unionslagstiftningen / on asiaa koskevan unionin yhdenmukaistamislainsäädännön vaatimusten mukainen / jest zgodny z odnośnymi wymaganiami unijnego prawodawstwa harmonizacyjnego / Shoduje se s následující příslušnou evropskou harmonizační legislativou / V skladu s harmonizirano zakonodajo Unije / Je v súlade s uplatniteľnými harmonizačnými právnymi predpismi EÚ / Megfelel a következõ alkalmazandó uniós harmonizációs szabályozásnak / Este conform cu legislația aplicabilă de armonizare de mai jos

Directive ATEX / ATEX Directive / ATEX Richtlinie / Directiva ATEX / Direttiva ATEX / Diretiva ATEX / ATEX-Richtlijn / ATEX-direktivet / ATEX-direktivi / Dyrektywa ATEX / Směrnice ATEX / Direktiva ATEX / Smernica ATEX / ATEX-irányelv	
 II 2G Ex h IIA TX Gb	
NF EN ISO 80079-36	
Procédure d'évaluation de la conformité : Module A Documentation technique (Annexe VIII) archivée par : / Conformity assessment procedure: Module A Technical documentation (ANNEX VIII) recorded by: / Verfahren zur Konformitätsbewertung: Modul A Technische Unterlagen (ANLAGE VIII) archiviert durch: / Procedimiento de evaluación de la conformidad: Módulo A Documentación técnica (ANEXO VIII) archivada por: / Procedura di valutazione della conformità: Modulo A Documentazione tecnica (ALLEGATO VIII) archiviata a cura di: / Procedimento de avaliação da conformidade: Módulo A Documentação técnica (ANEXO VIII) arquivada por: / Conformiteitsbeoordelingsprocedure: Module A Technische documentatie (BIJLAGE VIII) gearhiveerd door: / Förfarande för bedömning av överensstämmelse: Modul A Teknisk dokumentation (BILAGA VIII) arkiverad av: / Vaatimusten mukaisuusarviointimenetelmä: moduuli A Tekninen dokumentaatio (LIITE VIII) arkistoitu: / Procedura oceny zgodności: Modul A Dokumentacji technicznej (ZAŁĄCZNIK VIII) zarchiwizowane przez: / Postup posuzování shody: Modul A Technická dokumentace (PŘÍLOHA VIII) archivována: / Postopek preverjanja skladnosti: Modul A Tehnična dokumentacija (PRILOGA VIII), arhiviral: / Postup posudzovania zhody: Modul A Technická dokumentácia (PRÍLOHA VIII) archivovaná prostredníctvom: / Megfelelőségértékelési eljárás: A. modul Műszaki dokumentáció (VIII. MELLÉKLET) archiválta: / Procedura de evaluare a conformității: Modulul A Documentația tehnică (ANEXA VIII) este arhivată de:	
INERIS 0080 - 60550 Verneuil-en-Halatte – France	
N°INERIS 031908 / 16	2014/34/UE

La présente déclaration de conformité est établie sous la seule responsabilité du fabricant / This declaration of conformity is issued under the sole responsibility of the manufacturer / Die alleinige Verantwortung für die Ausstellung dieser Konformitätserklärung trägt der Hersteller / La presente declaración de conformidad se expide bajo la exclusiva responsabilidad del fabricante / La presente dichiarazione di conformità è rilasciata sotto la responsabilità esclusiva del fabbricante / A presente declaração de conformidade é emitida sob a exclusiva responsabilidade do fabricante / Deze conformiteitsverklaring wordt verstrekt onder volledige verantwoordelijkheid van de fabrikant / Denna försäkran om överensstämmelse utfärdas på tillverkarens eget ansvar / Tämä vaatimustenmukaisuusvakuutus on annettu valmistajan yksinomaisella vastuulla / Niniejsza deklaracja zgodności wydana zostaje na wyłączną odpowiedzialność producenta / Toto prohlášení o skodě se vydává na výhradní odpovědnost výrobce / Za izdajo te izjave o skladnosti je odgovoren izključno proizvajalec / Toto vyhlásenie o zhode sa vydáva / na vlastnú zodpovednosť výrobcu / Ezt a megfelelőségi nyilatkozatot a gyártó kizárólagos felelőssége mellett adják ti / Prezenta declarație de conformitate este emisă pe răspunderea exclusivă a producătorului.



Hervé WALTER

Directeur Innovation & Développement / Innovation & Development
Director / Direktor für Innovation & Entwicklung / Director de
Inovación y Desarrollo / Direttore Innovazione e sviluppo
/ Diretor de Inovação / Manager Innovatie en Ontwikkeling / Direktör
för Forskning och Utveckling / Innovaatio- ja kehitysohjaaja
/ Dyrektor ds. Innowacji i Rozwoju / Ředitel pro inovace a vývoj
/ Direktor za inovacije in razvoj / Riaditeľ pre inováciu a rozvoj
/ Innovációs és fejlesztési igazgató / Director Inovație și Dezvoltare

Fait à Meylan, le / Established in Meylan, on / Geschehen zu Meylan, am / En Meylan, a / Redatto a Meylan, / Vastgesteld te Meylan, / Ufformat i Meylan, den / Meylan, Ranska, / Sporządzono w Meylan, dnia / Meylan, dnia / V Meylanu, / V Meylan dňa / Kelt Meylanban, / Întocmită la Meylan, pe data de 23/09/2019 - 09/23/2019



INSTALLATION AND SAFETY INSTRUCTIONS

TRANSLATION FROM THE ORIGINAL MANUAL

IMPORTANT : Before assembly and start-up, please read and clearly understand all the documents relating to this equipment (professional use only).

THE PICTURES AND DRAWINGS ARE NON CONTRACTUAL. WE RESERVE THE RIGHT TO MAKE CHANGES WITHOUT PRIOR NOTICE.

SAMES KREMLIN SAS
13, chemin de Malacher
38 240 - MEYLAN - France
☎ : 33 (0)4 76 41 60 60

www.sames-kremlin.com

1. SAFETY INSTRUCTIONS

GENERAL SAFETY INSTRUCTIONS



CAUTION : The equipment can be dangerous if you do not follow our instructions concerning installation and servicing described in this manual and in accordance with applicable European standards and local national safety regulations.

Please carefully read all the instruction literature before operating your equipment.

Only trained operators can use the equipment.

The foreman must ensure that the operator has understood the safety instructions for this equipment as well as the instructions in the manuals for the different parts and accessories.

Read carefully all instruction manuals, label markings before operating the equipment.

Incorrect use may result in injury. This equipment is for professional use only. It must be used only for what it has been designed for. Never modify the equipment. The parts and accessories supplied must be regularly inspected. Defective or worn parts must be replaced.











Guards (motor cover, coupling shields, connectors,...) have been designed for a safe use of the equipment.

The manufacturer will not be held responsible for bodily injury or failure and / or property damage due to destruction, the overshadowing or the partial or total removal of the guards.

Never exceed the equipment components' maximum working pressure.

Comply with regulations concerning safety, fire risks, electrical regulations in force in the country of final destination of the material. Use only products or solvent compatible with the parts in contact with the material (refer to data sheet of the material manufacturer).

PICTOGRAMS

					
NIP HAZARD	WARNING MOVING ELEVATOR	WARNING MOVING PARTS	WARNING MOVING SHOVEL	DO NOT EXCEED THIS PRESSURE	HIGH PRESSURE HAZARD
					
RELIEF OR DRAIN VALVE	WARNING HOSE UNDER PRESSURE	WEAR GLASSES OBLIGATORY	WEAR OF GLOVES IS OBLIGATORY	PRODUCT VAPOR HAZARDS	WARNING HOT PARTS OR AREAS
					
ELECTRICAL HAZARD	WARNING FIRE HAZARDS	EXPLOSION HAZARDS	GROUNDING	WARNING (USER)	WARNING SERIOUS INJURIES

PRESSURE HAZARDS



Current legislation requires that an **air relief valve** be fitted in the air supply circuit to the air motor to prevent over pressurisation. This safety feature, ensures that it is not possible to supply the air motor with excessive air pressure that may cause injury.

Please ensure that a **material drain valve** is fitted in the fluid circuit to drain and depressurise the circuit. Once depressurised and drained, work /servicing may then commence on the equipment. Please remember to close these valves when restarting the system.

HIGH PRESSURE INJECTION HAZARDS



When working with high pressure equipment, special care is required. Fluid leaks can occur. There is a risk of material being injected to any exposed parts of body, this could cause severe injury :



- medical care must be sought immediately if paint is injected under the skin or in other parts of the body (eyes, fingers).
- never point the spray gun at any one. Never try to stop the spray with your hands or fingers nor with rags or similars.
- **follow the shut down procedure and always depressurize air and fluid circuits** before carrying out any servicing on the gun (cleaning, checking, maintenance of the material or cleaning of the gun nozzles).
- for the guns equipped with a safety device, always lock the trigger when not in use.

FIRE - EXPLOSION - SPARKS - STATIC ELECTRICITY HAZARDS

A poor earth connection, inadequate ventilation, sparks or static electricity can cause an explosion or fire. to avoid these risks when using or servicing SAMES KREMLIN equipment, the following safety procedures must be followed :



- ensure a good earth connection and ground the parts to be handled i.e. solvents, materials, components and equipment,
- ensure adequate ventilation,
- keep working area clean and free from waste solvents, chemicals, or solid waste i.e. rags, paper and empty chemicals drums,
- never use electrical switches / power if in an atmosphere of volatile solvent vapour,
- stop working immediately in case of electrical arcs,
- never store chemicals and solvents in the working area.
- use paint whose flash point is the highest possible to prevent from any formation of gas and inflammable vapours (refer to materials' safety instructions),
- install a cover on the drums to reduce the diffusion of gas and vapours in the spraybooth.

TOXIC PRODUCT HAZARDS



Toxic products or vapours can cause severe injury not only through contact with the body, but also if the products are ingested or inhaled. It is imperative :



- to know the material products and their risks,
- notified or hazardous materials must be stored in accordance with the regulations,
- the material must be stored in an appropriate container, never place materials in a container where there is a risk of spillage or leakage,
- a procedure must be applied for the safe disposal of waste material. It must comply with all prevailing regulations and legislations of the country where the equipment is to be used,
- protective clothing should always be worn in compliance with the material manufacturers' recommendations,
- depending on the application and chemical safety instructions, safety glasses, hearing protective earplug, gloves, foot wear, protective masks and possible breathing equipment should be worn to comply with the regulations (Refer to chapter "Safety equipment of SAMES KREMLIN selection guide).



CAUTION!

It is forbidden to use material containing high concentrations of halogenated hydrocarbon solvents with **aluminium** or **zinc fillers**. Non-compliance with the instructions may cause explosion risk causing serious or fatal injury.



EQUIPMENT REQUIREMENTS

Guards (motor cover, coupling shields, connectors,...) have been designed for a safe use of the equipment.

The manufacturer will not be held responsible for bodily injury or failure and / or property damage due to destruction, the overshadowing or the partial or total removal of the guards.

PUMP



Before carrying out any work, it is imperative to read and clearly understand the disassembly and reassembly instructions before servicing. The operator must understand the equipment and the safety instructions. These instructions are available in the equipment manuals.



The air motor is designed to be mounted with a pump. Never modify any components or couplings. When operating, please keep hands away from moving parts. Before starting up the equipment, please read the PRESSURE RELIEF instructions. Please ensure that any relief or drain valves fitted are in good working order.

HOSES

- Keep hoses out of circulation areas, moving parts or hot surfaces,
- Never expose product hoses to temperature higher than + 60°C / 140° F or lower than 0°C / 32° F,
- Never pull or use the hoses to move the equipment,
- Tighten all fittings as well as the hoses before operating the equipment,
- Check the hoses regularly; change them if they are damaged,
- Never exceed the maximum working pressure (MWP) indicated on the hose.

USED PRODUCTS

Considering the wide variety of products that are available and can be used in our equipment it is impossible to check and make recommendations for all chemical data, regarding the risks of possible chemical attack and their long term chemical reaction

SAMES KREMLIN can not be held liable for :

- compatibility of wetted parts,
- risks to staff and the surroundings,
- for worn or defective parts, for faulty equipment or units, or the quality of final product.

It is the responsibility of the user to know and prevent any possible risks such as toxic vapours, fires or explosions. He shall determine the risks of immediate reactions or pursuant to repeated exposures of the staff,

SAMES KREMLIN shall not be liable for physical injuries, direct or indirect material damages caused by the use of chemicals.

2. HANDLING



Check the weight and the dimensions of the equipment
(☞ refer to 'Technical features' section of the instruction manual)

If weight and dimensions are too important, the unloading must be carried out by means of a forklift or any other appropriate means with a qualified personnel and in a clear horizontal area to prevent from risks of damage injury or an accident.

The centre of gravity is not in the centre of the machine : carry out by hand a stability-test after having lifted the whole at 10 cm / 3.937" maximum.

After the unloading, the handling of the whole (eg: elevator pump) is carried out by means of a pallet truck taking the bottom part of the frame.

Remark : Each pump motor is fitted with a ring. The ring is designed for the hoisting of one pump and can not be used for the handling of the complete assembly.

3. STORING

Storing before installation :

- Storing ambient temperature : 0 / +50 °C / 0 / +122°F
- Protect the whole against dust, water trickling, dampness and shocks.

Storing after installation :

- Operating temperature : +15 / +35 °C / +59 / +138.2° F
- Protect the whole against dust, water trickling, dampness and shocks.

4. INSTALLATION OF THE EQUIPMENT

The machine is installed on a stable horizontal floor (for eg a concrete flag).

The machine shall be made stable by the use of holding down bolts or by the use of other anchoring methods, strong enough to prevent unintended bodily movement of the equipment.



To avoid risks caused by static electricity, the equipment as well as its components must be grounded.

- **For the pumping equipments** (pumps, pneumatic rams, frame...), a section wire of 2.5 mm² is fixed on the material. Use this wire to connect the material to "the general ground". In case of severe environments (mechanical protection of the wire of earthing insufficient, vibrations, mobile material...) where function damages at the ground are probable, the user have to replace the provided wire of 2.5 mm² by a device more adapted to its environment (wire with a more important section, bonding strip, fixing by thimble with eyelet...).

The continuity of the ground must be controlled by a qualified electrician. If the continuity of the ground is not ensured, check the terminal, the wire and the earthing point. **Never** use the material without have solved this problem.

- In the severe cases of environments (mechanical protection of the wire of earthing insufficient, vibrations, mobile material...) where damages of the function put at the ground are probable, the user will have to replace the wire of 2.5 mm² provided, by a device more adapted to its environment (wire of more important section, bonding strip, fixing by thimble with eyelet...),
- **The gun** must be 'grounded' via a material hose or an air hose. In case of spraying by means of a gun with cup, the air hose must be conductive,
- **The materials to be painted** must also be grounded.

All the materials situated in the working area shall be grounded.



- **Never store** more than necessary inflammable materials inside the working area,
- The materials must be stored into **approved drums** and grounded,
- Use only grounded **metals containers** for the use of cleaning solvents,
- **Cardboard and paper are prohibited.**

5. MARKING OF THE EQUIPMENT



Each equipment has a label plate with the name of the manufacturer, the equipment part number, the interesting informations to use correctly the equipment (pressure, voltage,...) and sometimes the above pictogram.

The equipment is designed with and consists of high quality materials and components which can be re-used.

The 2012/19/UE European Directive covers all equipments with a crossed-out bin pictogram. Please inform yourself about the collection systems for electric and electronic equipments.

Please act in accordance with local rules and **do not dispose of old equipment with household wastes**. A correct disposal of old equipment will help prevent negative consequences for the environment and health.



PUMP

15-C50

Disassembly / Reassembly

TRANSLATION FROM THE ORIGINAL MANUAL

IMPORTANT : Before assembly and start-up, please read and clearly understand all the documents relating to this equipment (professional use only).

THE PICTURES AND DRAWINGS ARE NON CONTRACTUAL. WE RESERVE THE RIGHT TO MAKE CHANGES WITHOUT PRIOR NOTICE.

SAMES KREMLIN SAS
13, chemin de Malacher
38 240 - MEYLAN - France
☎ : 33 (0)4 76 41 60 60

www.sames-kremlin.com



CAUTION :

Before any action on the pump, the T lubricant should be removed, shut off the compressed air supply and depressurize the system.

The pump is manufactured under the ATEX agreement and can not be modified. SAMES KREMLIN will not be held responsible for any failure to comply with that instruction.

▪ GREASES AND GLUES

Index	Instruction	Description	Part number
A 1	PTFE grease	'TECHNILUB' grease (10 ml / 0.0026 US gal)	560.440.101
A 2	Anti-seize grease	Grease box (450 g / 0.99 lb)	560.420.005
C 1	Medium strength Aneorobic Pipe sealant	Loctite 5772 (50 ml / 0.013 US gal)	554.180.015
C 2	Low strength - Aneorobic Adhesive	Loctite 222 (50 ml / 0.013 US gal)	554.180.010

▪ FLUID MOTOR OR AIR MOTOR REPLACEMENT (REFER TO DOC. 573.474.050 & DOC. 573.435.050)

**Guards (air motor cover, coupling shields, housings ...) have been designed for safe use of the equipment.
The manufacturer will not be held responsible for bodily injury or failure and / or damage to property due to removal or partial removal of the guards.**

PUMP DRAINING

Guards (air motor cover, coupling shields, housings ...) have been designed for safe use of the equipment.

The manufacturer will not be held responsible for bodily injury or failure and / or damage to property due to removal or partial removal of the guards.

- Adjust the pump air inlet pressure to get 1 bar / 14.5 psi.
- Adjust the gun air inlet pressure to get 0 bar / 0 psi (Airmix® model).
- Remove the suction rod from the product container.
- Remove the aircap and the nozzle from the gun.
- Drain the residual product from the product container by triggering the gun.
- Clean the suction rod with a cloth and some solvent.
- Insert the suction rod in a solvent container.
- Trigger the gun towards an empty container until the solvent becomes clean.
- Adjust the pump air inlet pressure to get 1 bar / 14.5 psi.
- Stop the main air inlet.
- Trigger the gun one more time to empty the residual solvent from the gun.

PUMP SEPARATION / COUPLING PROCEDURE

Guards (air motor cover, coupling shields, housings ...) have been designed for safe use of the equipment.

The manufacturer will not be held responsible for bodily injury or failure and / or damage to property due to removal or partial removal of the guards.

To work on the pump, it requires to :

- Disassemble all the accessories of the pump (air inlet supply, rods, filter), if necessary.
- Put aside the pump, if necessary (the pump is fitted with an hoisting ring).

Separate the pump

- Stop the pump.
- Disconnect the pump air inlet.
- Remove the screw (12) from the pump bracket (11) and remove the washer (13).
- Remove the screws (5) from the coupling housing (4).
- Remove the coupling housings (4).
- Remove the pin (9) and the axis (8).
- Loosen the 4 screws (17) from the outlet flange.
- Slightly rotate the outlet flange counter clockwise.
- Separate the fluid section.

Coupling the pump

- Install the fluid section (2) at the 4 screws (17) level.
- Slightly rotate the outlet flange clockwise.
- Tighten the 4 screws (17).
- Apply grease (grease, model A1) on the axis (8) and install it in its housing.
- Install the pin (9) in the axis (8).
- Clip the coupling housings (4).
- Tighten the screw (5) of the coupling housing.
- Tighten the screw (12) of the pump bracket.

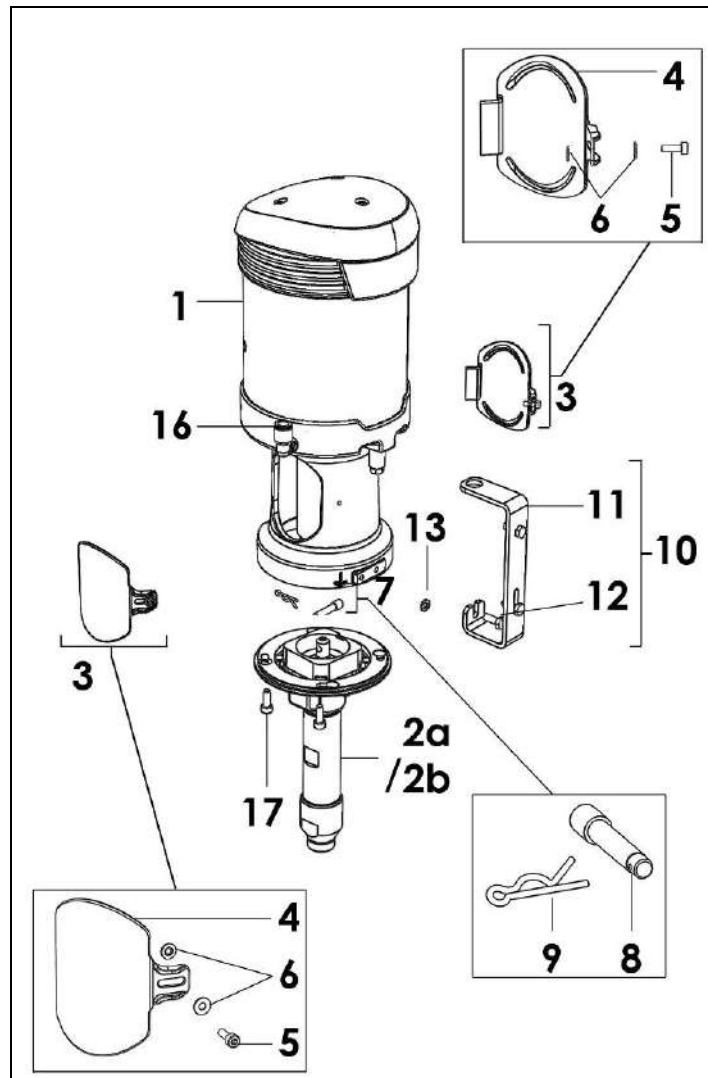

DISASSEMBLY / REASSEMBLY OF THE FLUID SECTION

Guards (air motor cover, coupling shields, housings ...) have been designed for safe use of the equipment.

The manufacturer will not be held responsible for bodily injury or failure and / or damage to property due to removal or partial removal of the guards.

Disassembly

- Place the fluid section in a vice.
- Unscrew the pump foot (14a / 14b) with two wrenches.
- Remove the stop ring (12) and the ball (13).
- Remove the cylinder (9) with a wrench.
- Remove the 2 seals (10).
- Remove the piston (16).
- Unscrew the exhaust valve (20) with a wrench and an hexagon key.
- Remove the carbide seat (19) and the ball (17).
- Remove piston seal (18).
- Remove the outlet from the vice.
- Remove the stop ring (7).
- Remove the MB-A / GT cartridge (2a / 2b).

Assembly



Apply a light coating of grease to the seals.



If the piston is damaged, the replacement of it involves the systematic replacement of the cartridge.

- Place the fluid section in a vice.
- Grease (model A1) the MB-A / GT cartridge (2a / 2b).
- Install the MB-A / GT cartridge (2a / 2b) on the flange (6) with tool for cartridge assembly (4a / 4b) and install the stop ring (7).
- Grease the piston seal (18) and install it on the valve (20).
- Apply glue (model C1) on the seat (19).
- Install the valve assembly (20) on the piston (16) with a wrench and an hexagon key.
- Apply grease (model A1) on the tool for packing assembly (5) and the piston and install the assembly into the flange (6).
- Grease the seals (10) and install them on the cylinder (9).
- Grease (model A2) the thread of the cylinder (9) and tighten it on the flange (6).
- Install the ball (13) and the stop ring (12) into the pump foot (14a / 14b).
- Screw the pump foot (11a / 11b).

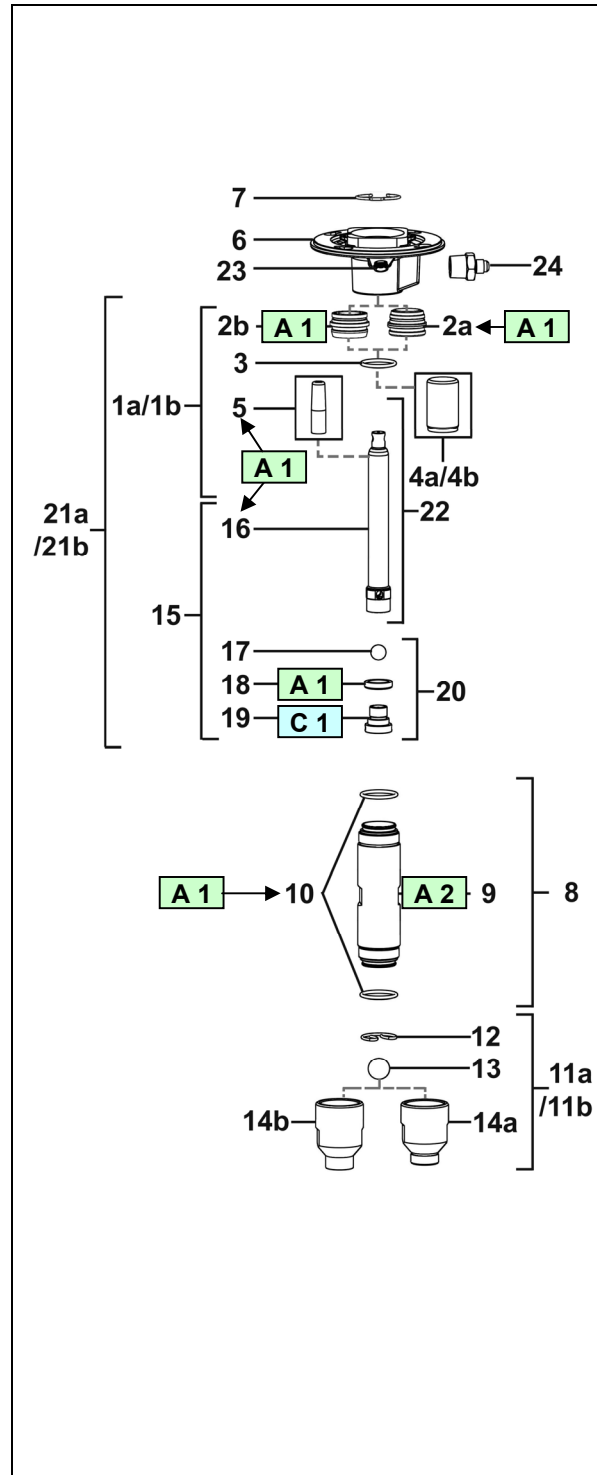

MOTOR

Guards (air motor cover, coupling shields, housings ...) have been designed for safe use of the equipment.
The manufacturer will not be held responsible for bodily injury or failure and / or damage to property due to removal or partial removal of the guards

The maintenance consists in changing the wetted or worn parts and to clean the parts with compatible materials without using abrasive materials that can damage them. The O-Rings are installed with PTFE grease. Make sure the seals are not damaged, one injured seal can lead to a motor malfunction.

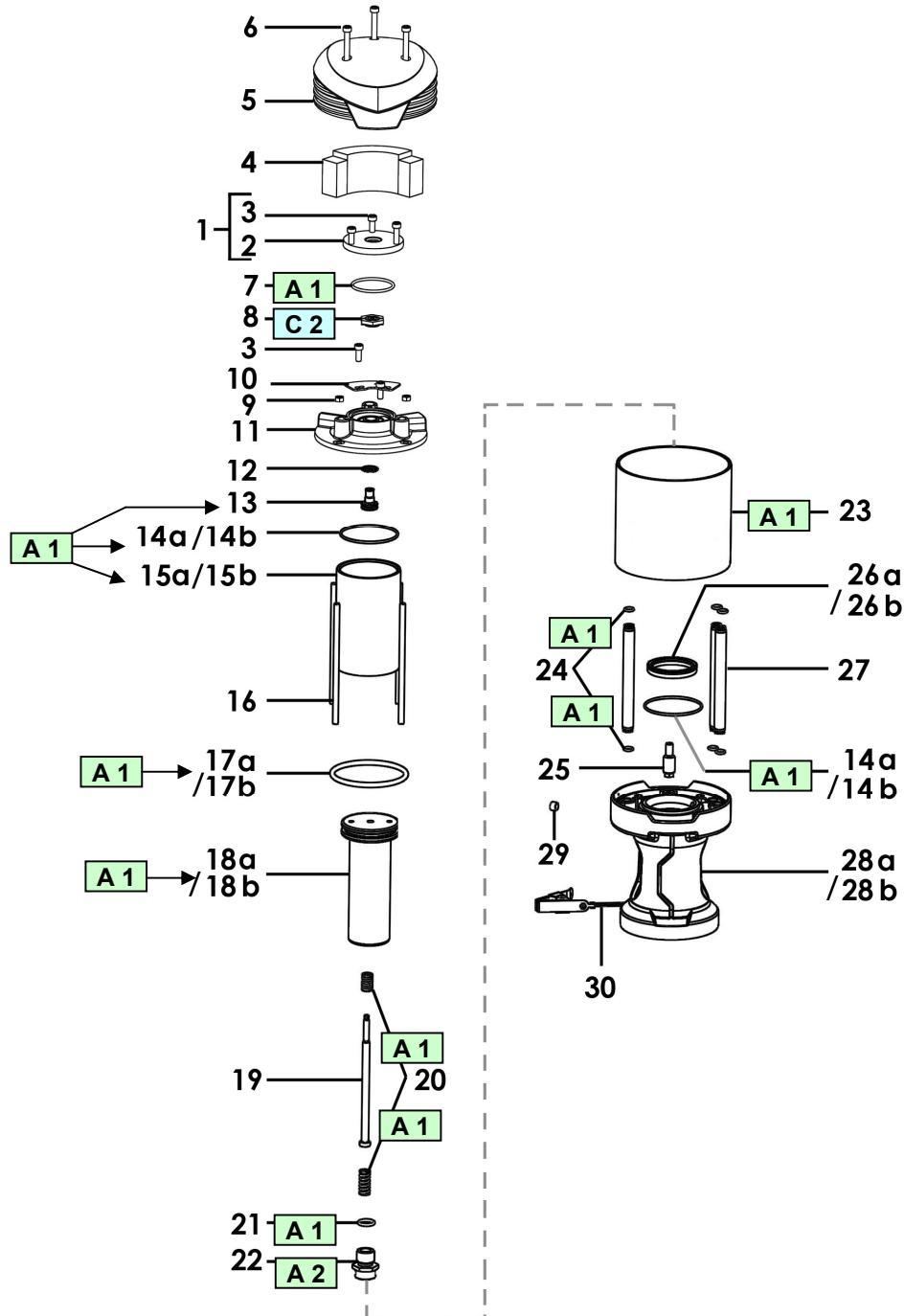

Disassembly

- Unscrew the 3 screws (6) from the cover (5) with an hexagon key.
- Remove the cover (5).
- Remove the muffler (4).
- Unscrew the 2 screws (3) from the exhaust grid (10) with an hexagon key.
- Remove the exhaust grid (10).
- Unscrew the 3 screws (3) from the cover (2) with an hexagon key.
- Remove the cover (2).
- Remove the muffler (23).
- Unscrew the 4 nuts (9).
- Remove the reversing body (11).
- Remove the seal (14a / 14b).
- Remove the 3 connecting tubes (27).
- Remove the seals (24) from the connecting tubes (27).
- Remove the cylinder (15a / 15b).
- Remove the seal holder (13).
- Remove the piston assembly (17a / 17b) from the control rod assembly (19).
- Unscrew the coupling screw (22).
- Remove the O-Ring seal (21).
- Remove the piston (17a / 17b) from the control rod assembly (19).
- Remove the seal (18a / 18b).
- Remove the seal (14a / 14b).
- Remove the seal (26a / 26b) with a flat screwdriver.

Assembly



Apply a light coating of grease on the seals.



Installation direction of the seal (26a / 26b) : lip up.

- Pinch and install the seal (26a / 26b) on the motor flange (28a / 28b).
- Install the seal (14a / 14b) on the motor flange (28a / 28b).
- Install the seal (18a / 18b) on the piston (17a / 17b).
- Install the seal (21) on the coupling screw (22).
- Apply a light coating of grease on the spring (20) (grease, model A1).
- Install a spring (20) in the piston (17a / 17b).
- Install the control rod assembly (19) in the piston (17a / 17b).
- Install the second spring (20) in the piston (17a / 17b).
- Ensure that the control rod assembly (19) is outside the piston (17a / 17b).
- Screw the coupling screw (22) on the piston (17a / 17b).
- Install the piston (17a / 17b) / control rod assembly (19) on the motor flange (28a / 28b).
- Apply a light coating of grease on the seal holder (13) (grease, model A1).
- Install the seal holder (13) on the control rod assembly (19).
- Apply a light coating of grease on the cylinder (15a / 15b).
- Install the cylinder (15a / 15b) on the piston (17a / 17b) - control rod assembly (19).
- Install the seals (24) on the coupling tubes (27).
- Install the coupling tubes (27) on the motor flange (28a / 28b).
- Install the seal (14a / 14b) on the reversing body (11).
- Screw the reversing body (11) by means of the nuts (9) on the tie-rod (16).
- Apply a light coating of glue (glue, model C2) on the valve (8).
- Screw the valve (8) on the control rod assembly (19) with two wrenches.











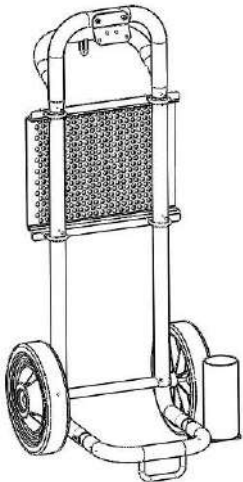
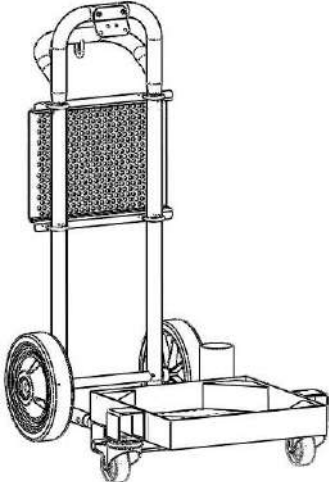



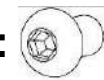





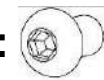

- Install the seal (7) on the cover (2).
- Install the cover (2) on the reversing body (11) and screw the three screws (3) with an hexagon key.
- Install the muffler (23) correctly oriented according to the notch.
- Fix the exhaust grid (10) with the 2 screws (3) on the reversing body (11).
- Install the muffler (4).
- Install the cover (5) and screw the 3 screws (6) with an hexagon key.

▪ **DEGREES OF WEAR**

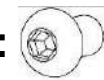
The wetted parts in contact with the material are subject to wear with time. It depends, of course, on the rates and duration of pump operating; also on the material handled.

**ASSEMBLAGE
ASSEMBLY
MONTAGE
MONTAJE**

**Chariot / Cart
Fahrgestell / Carretilla**

# 151 241 000	# 151 242 000							
								
<p>Poids chariot/ Cart weight/ Peso carretilla/ Gewicht fahrgestell: 9,6 Kg / 21.16 lbs</p>	<p>Poids chariot/ Cart weight/ Peso carretilla/ Gewicht fahrgestell: 23,7 Kg / 52.24 lbs</p>							
<table border="0"> <tr> <td data-bbox="386 1438 667 1585">  A : x 4 </td> <td data-bbox="727 1438 906 1585">  B : x 8 </td> <td data-bbox="983 1438 1161 1585">  C : x 8 </td> </tr> <tr> <td data-bbox="386 1626 587 1774">  D : x 10 </td> <td data-bbox="638 1626 759 1774">  x 1 </td> <td data-bbox="810 1626 963 1774">  x 1 </td> <td data-bbox="1008 1626 1161 1774">  x 1 </td> </tr> </table>		 A : x 4	 B : x 8	 C : x 8	 D : x 10	 x 1	 x 1	 x 1
 A : x 4	 B : x 8	 C : x 8						
 D : x 10	 x 1	 x 1	 x 1					
<p> 2 - 6</p>	<p> 7 - 11</p>							

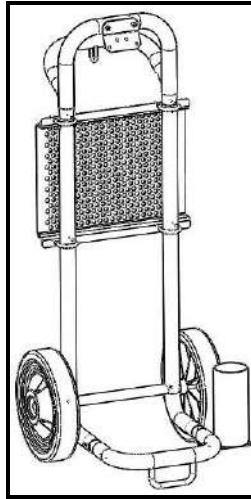

1

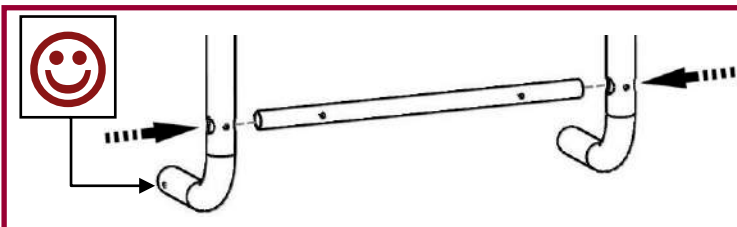
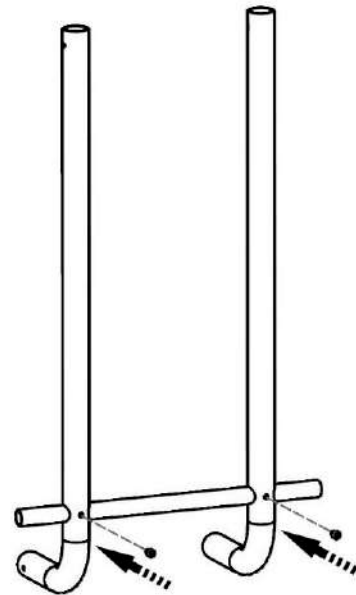
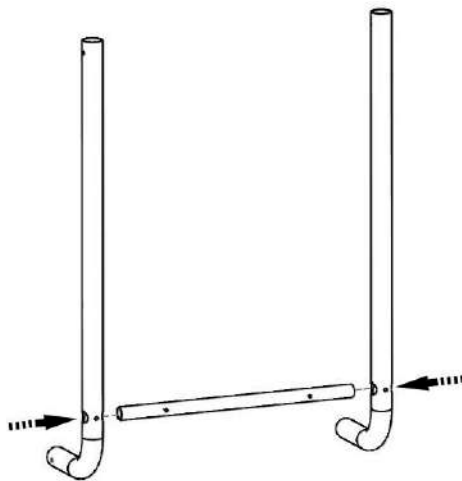

2

1

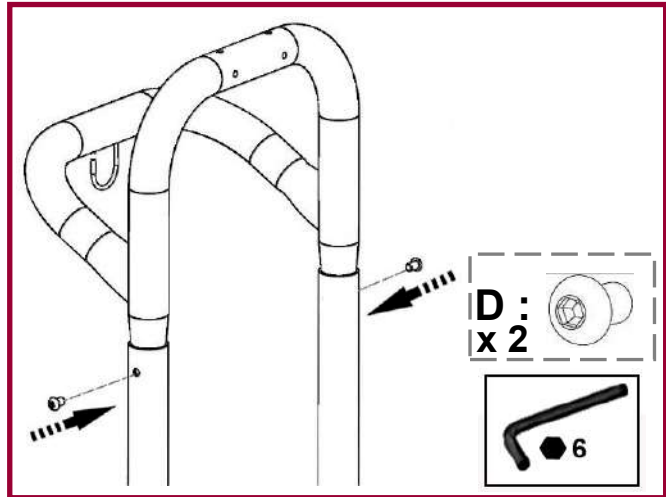
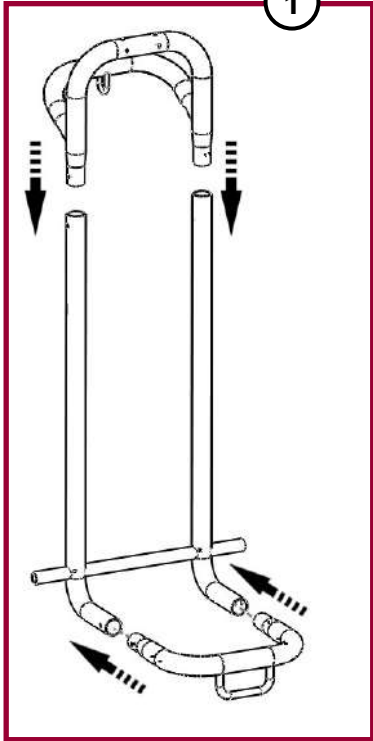

2

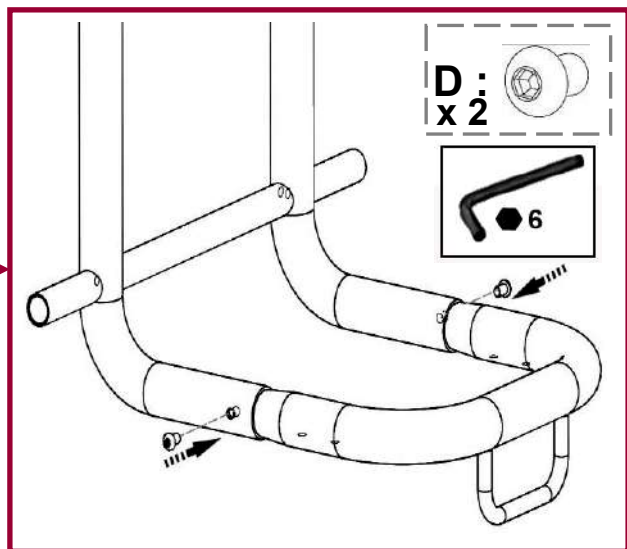
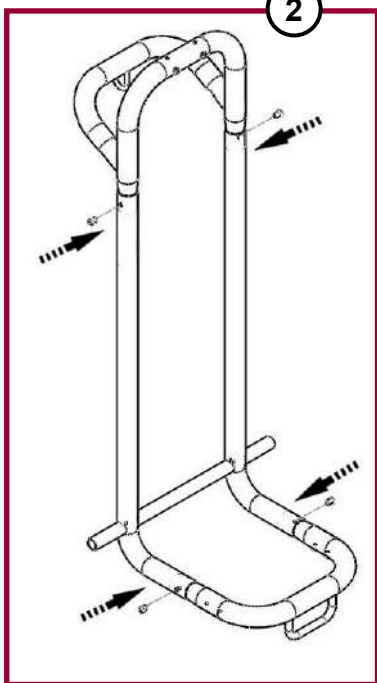

3

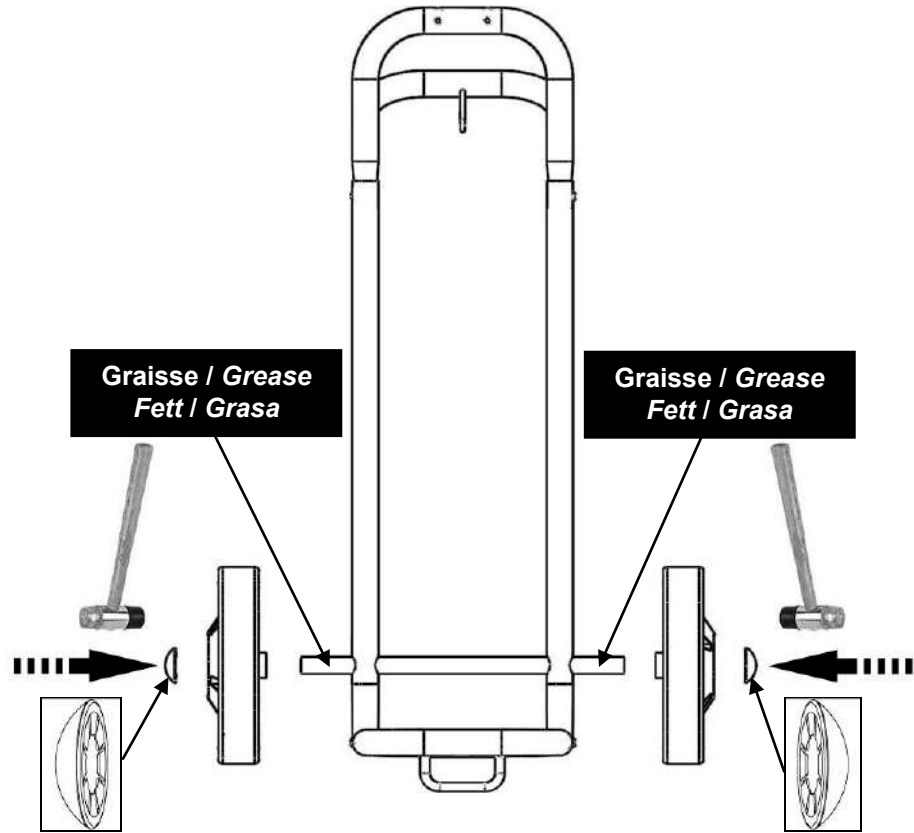

4



OU / OR
ODER / O

D :
x 2

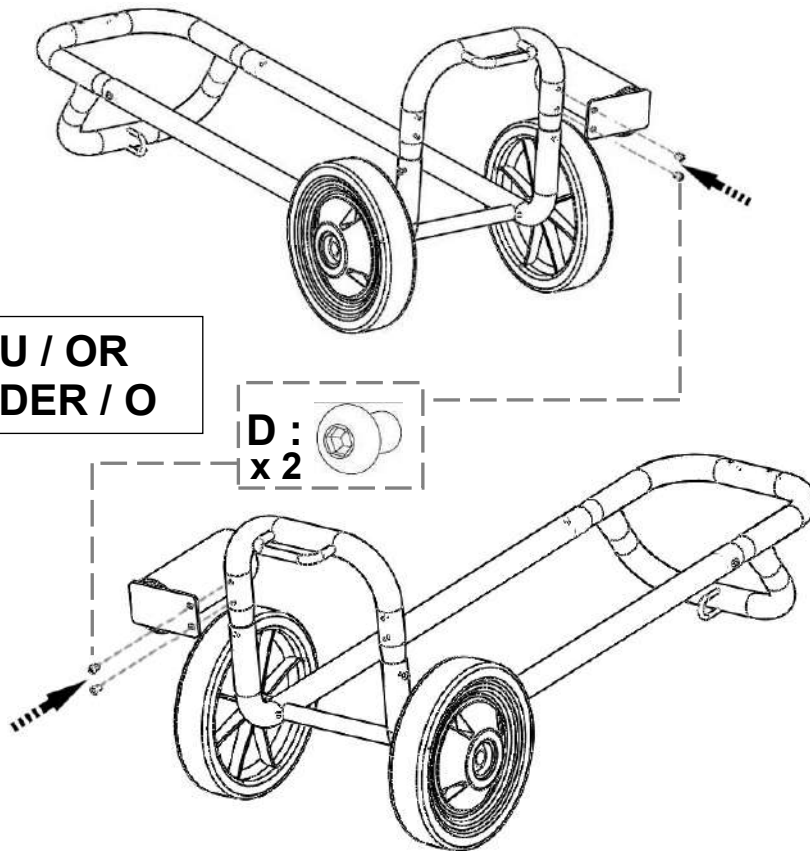

5A

Pompe / Pump / Pumpe / Bomba
15C25 / 30C25 / 15C50

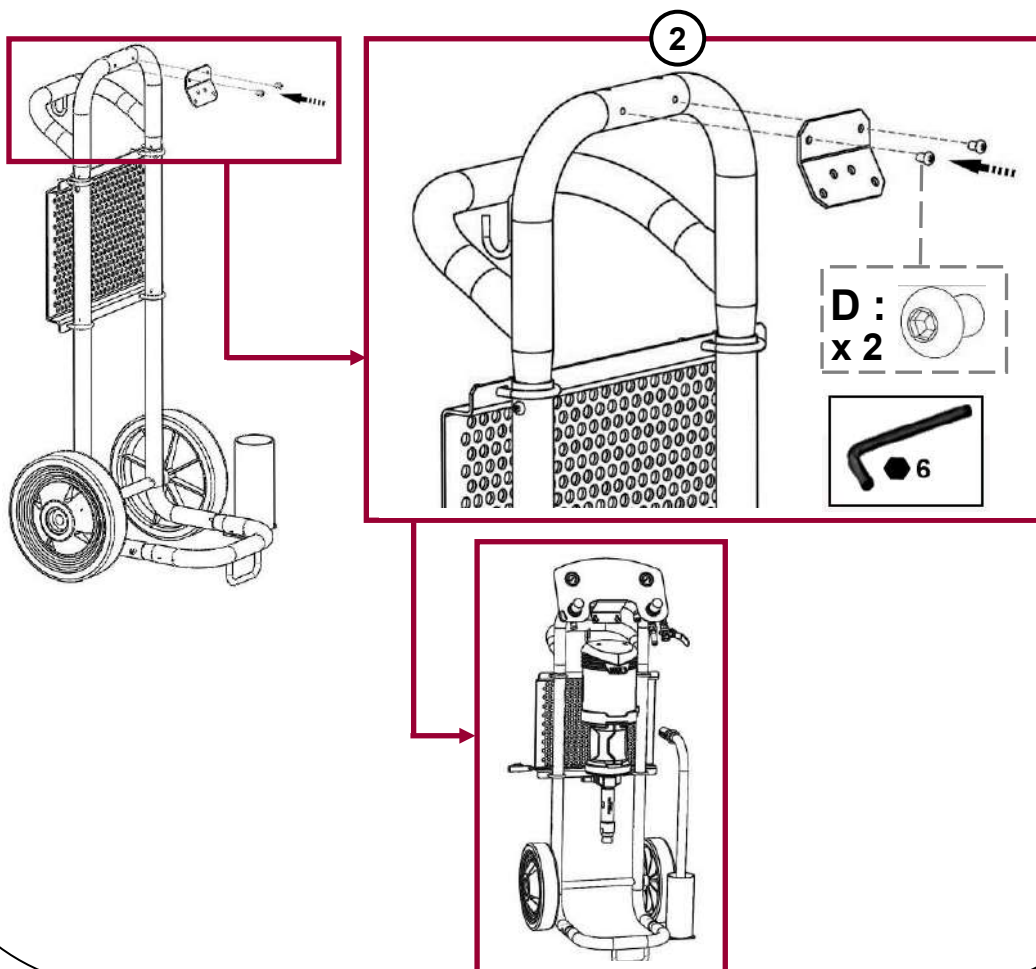
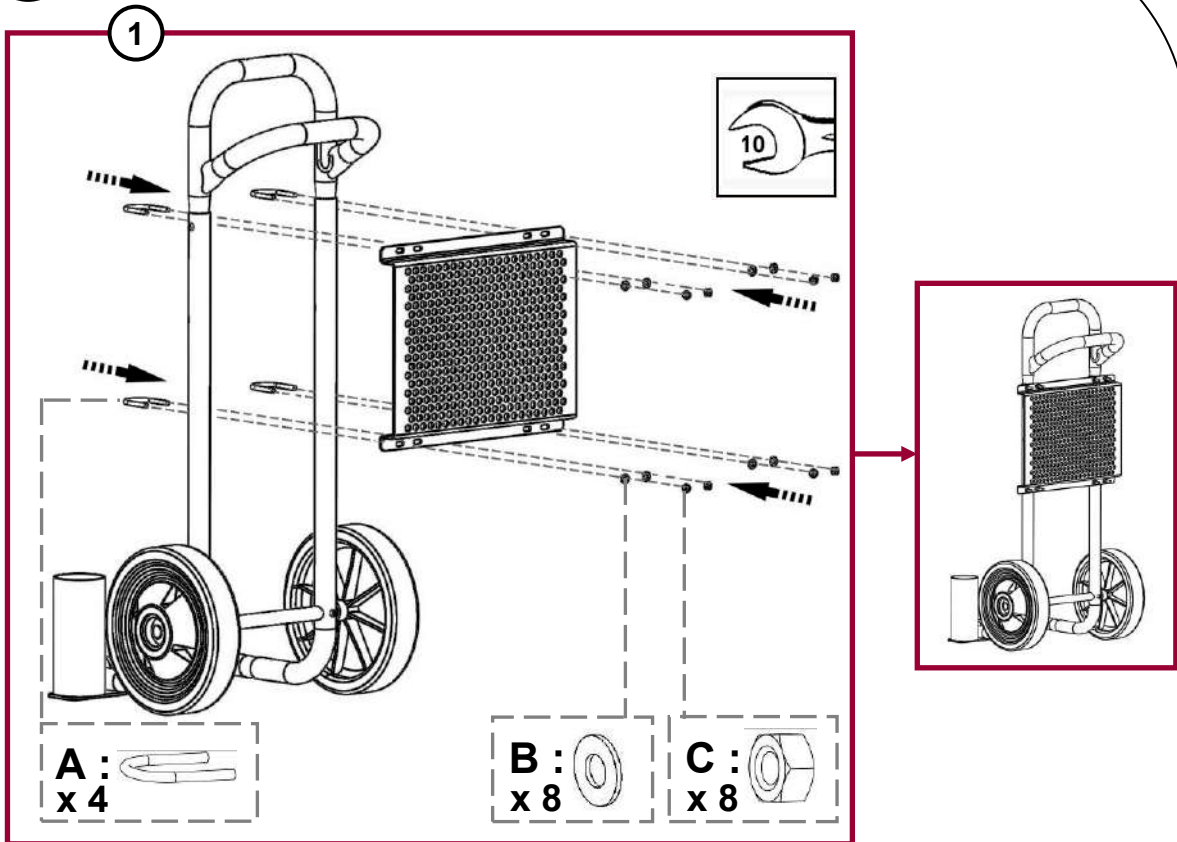

5B

Pompe / Pump / Pumpe / Bomba
20-25F / 40-25F
20-25 WB / 20-50F / 20-25 FT / 40-50 F / 40-50 WB
17 A2 / 34 A2
04-120 F / 08-120 F / 08-120 FT / 16-120 F / 16-120FT

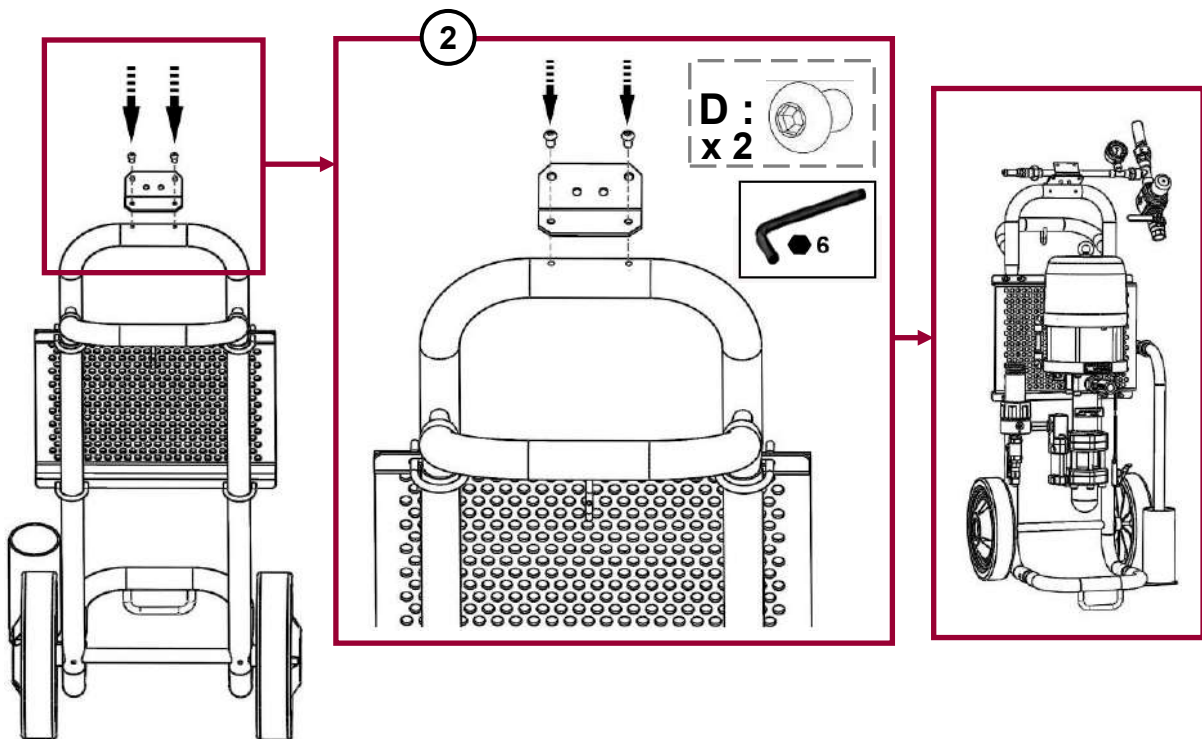
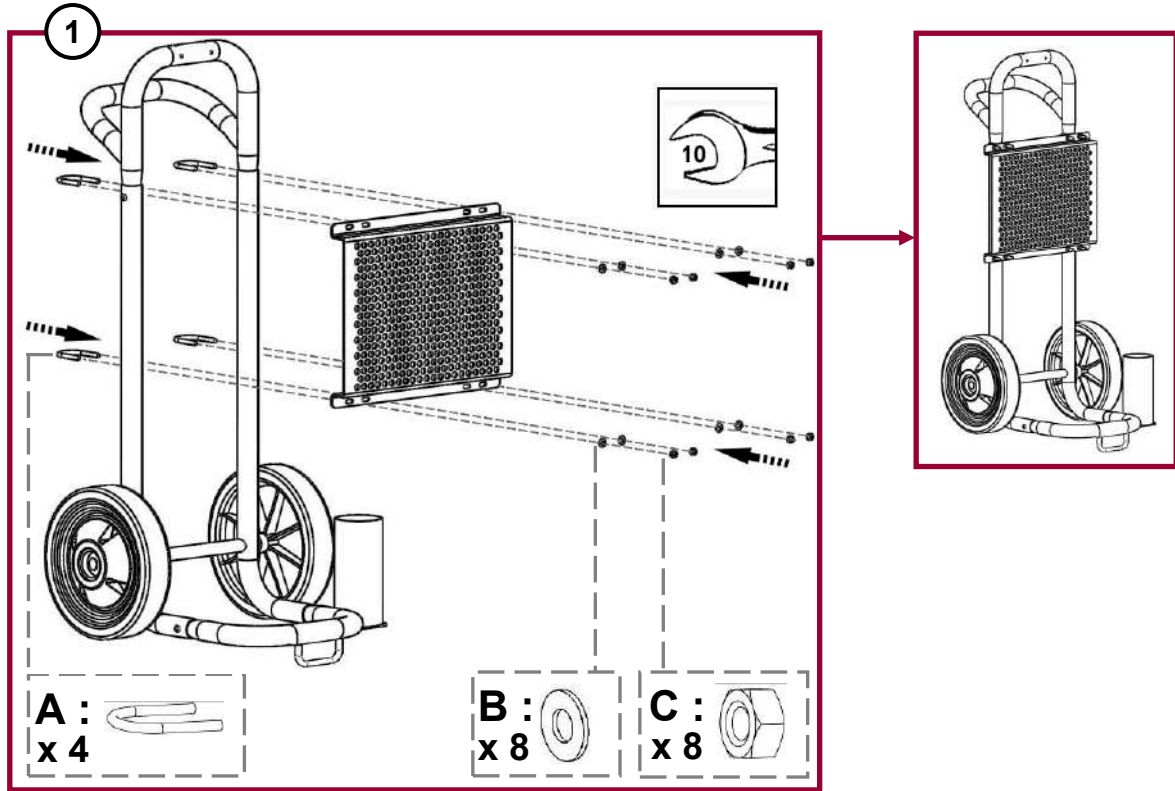

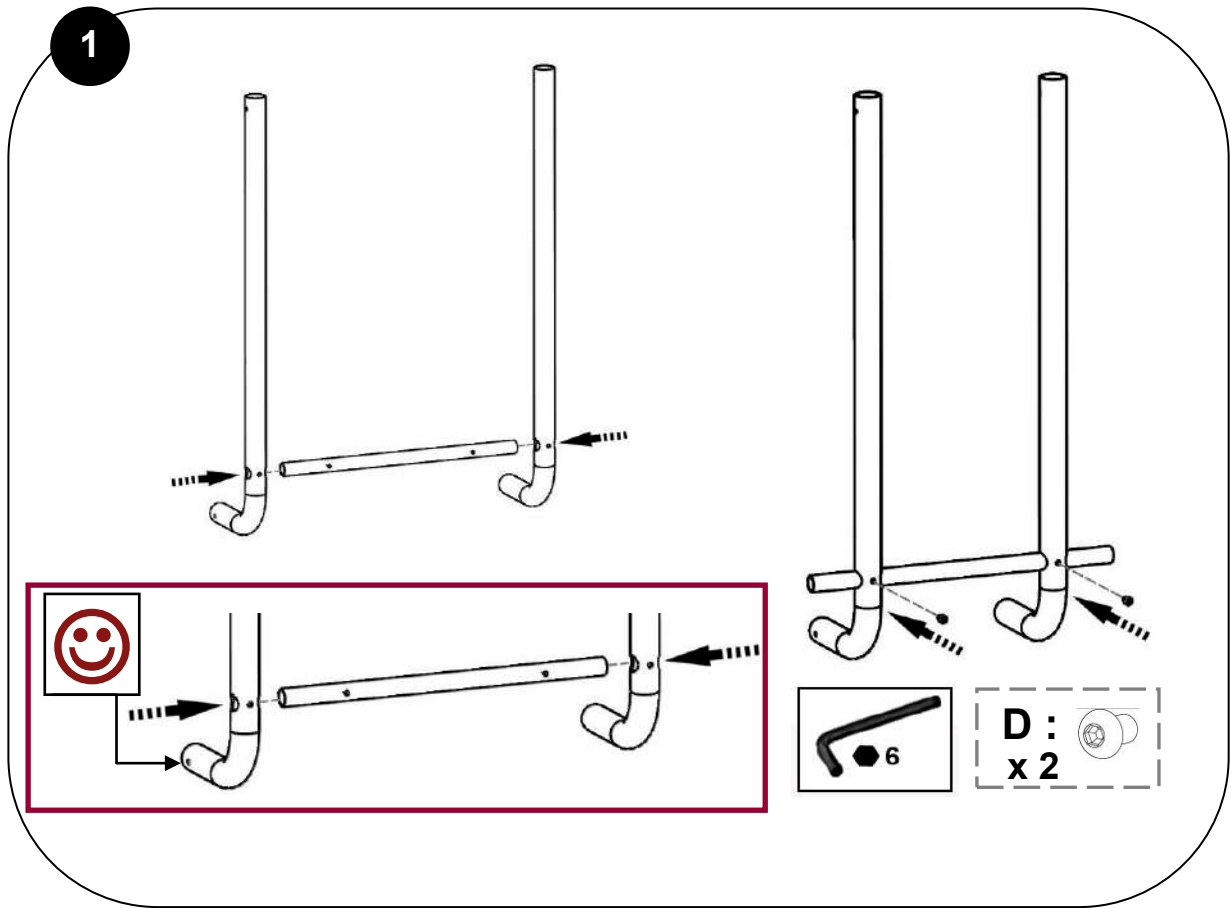
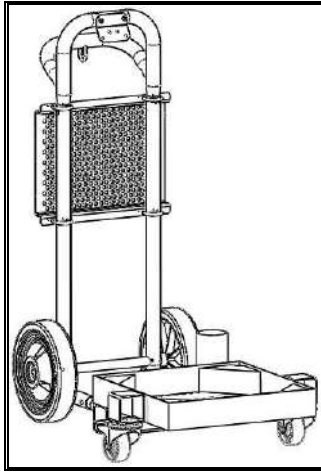

2

1

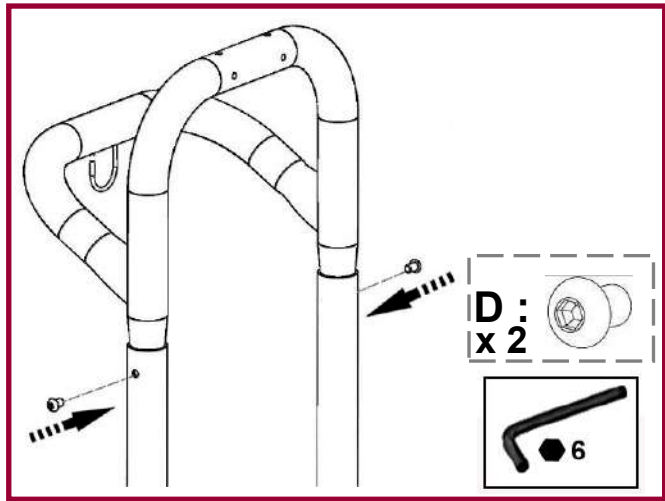
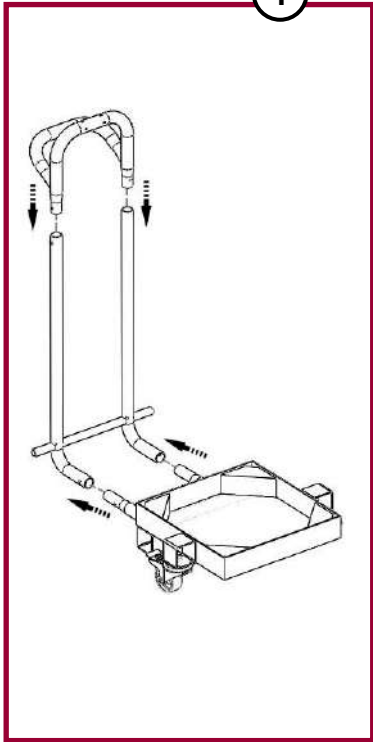

2

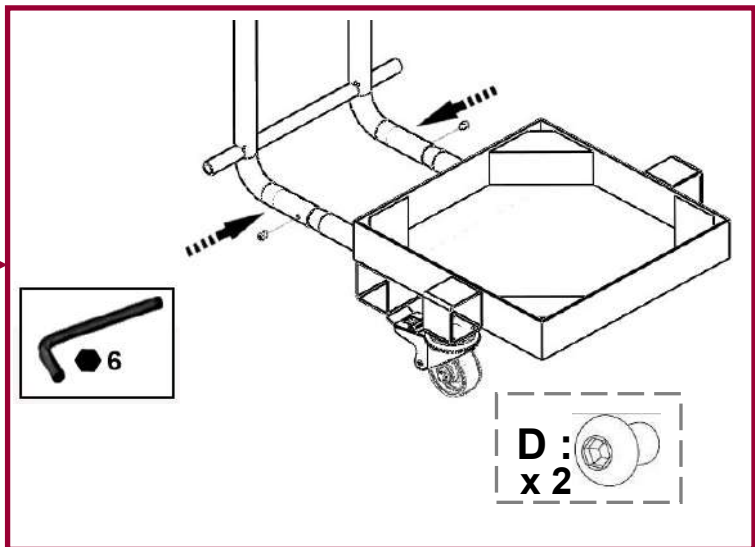
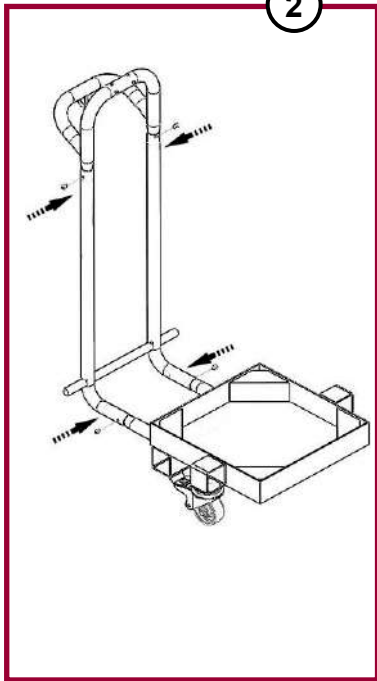

3

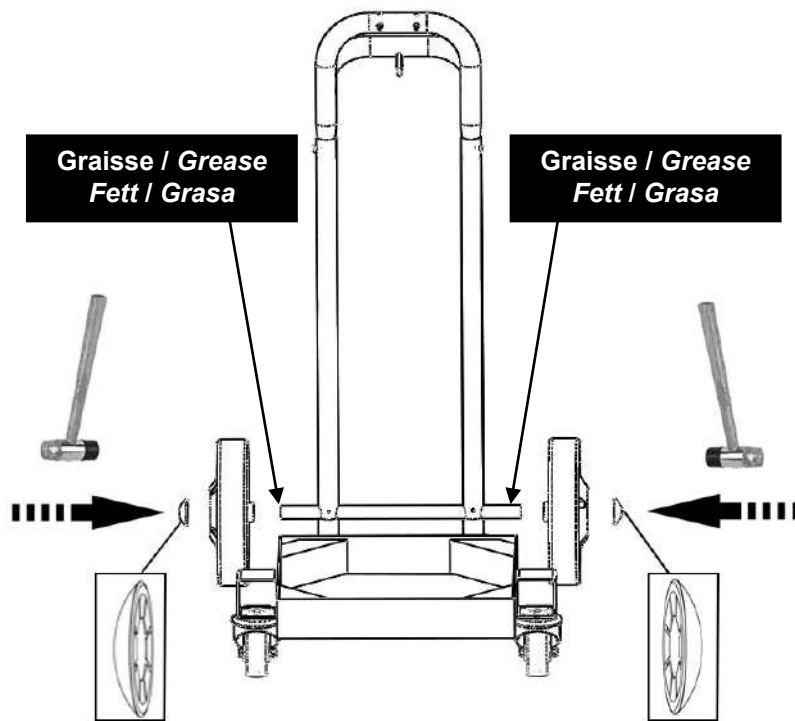

4

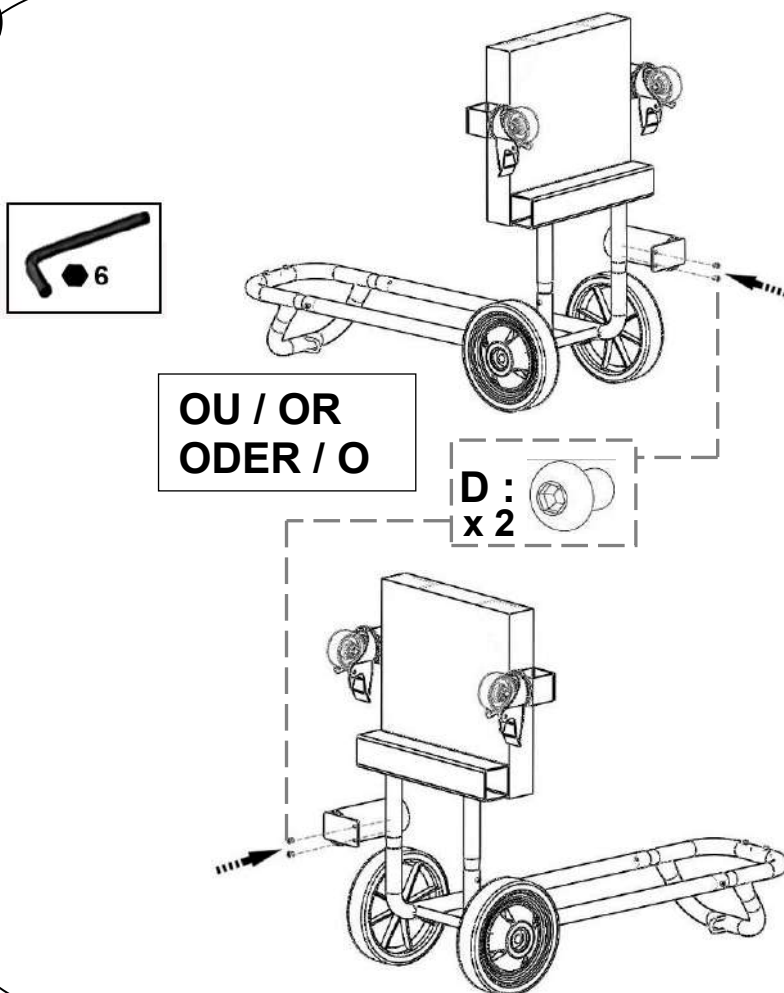

5A

Pompe / Pump / Pumpe / Bomba
15C25 / 30C25 / 15C50

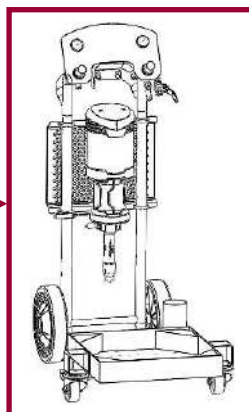
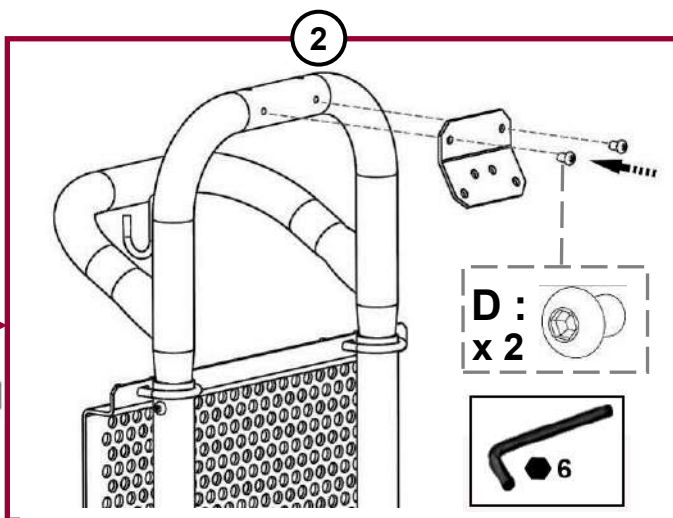
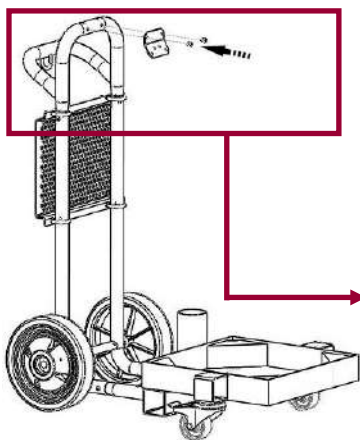
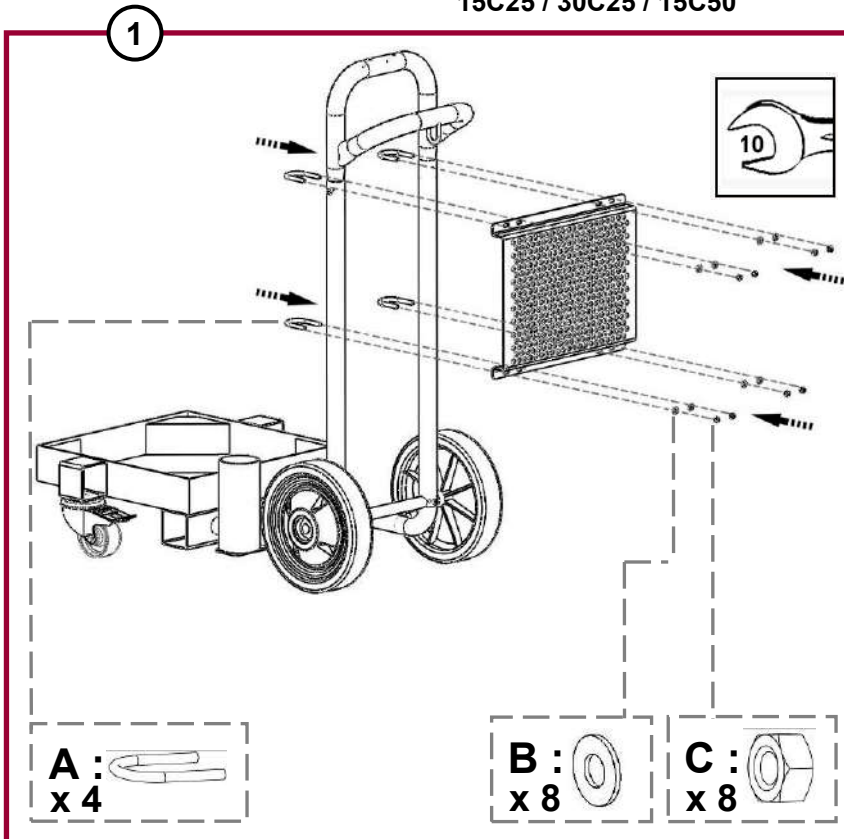

5B

Pompe / Pump / Pumpe / Bomba
20-25F / 40-25F
20-25 WB / 20-50F / 20-25 FT / 40-50 F / 40-50 WB
17 A2 / 34 A2
04-120 F / 08-120 F / 08-120 FT / 16-120 F / 16-120FT

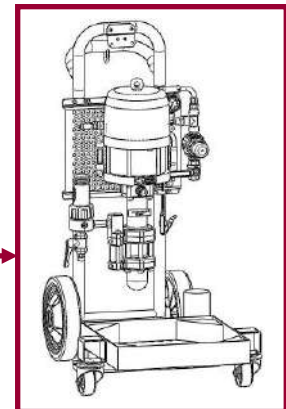
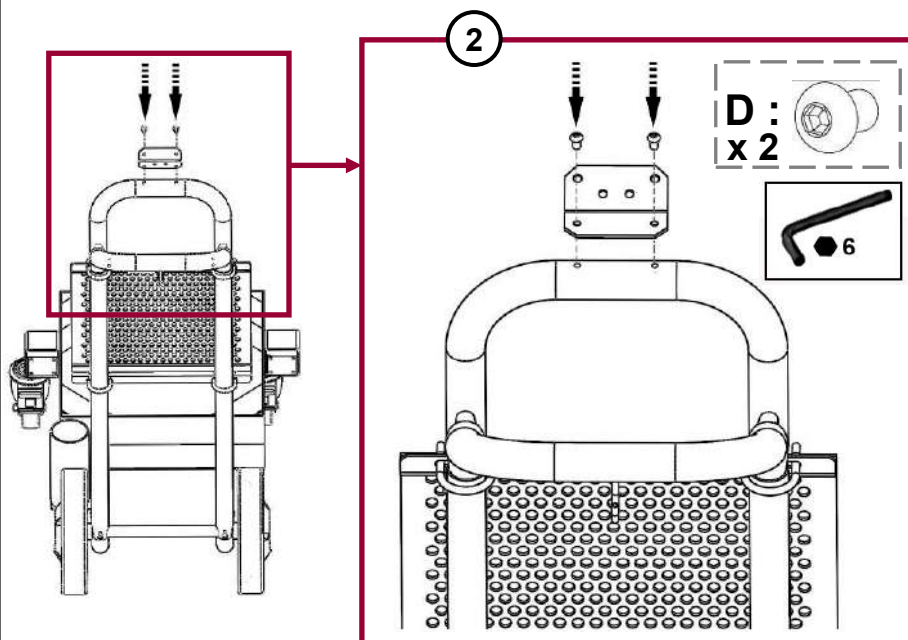
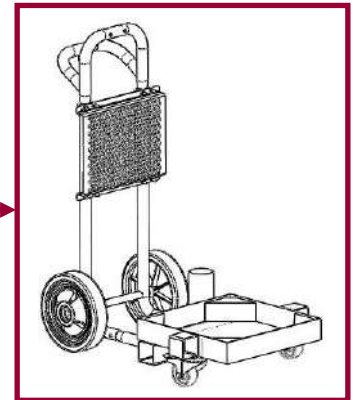
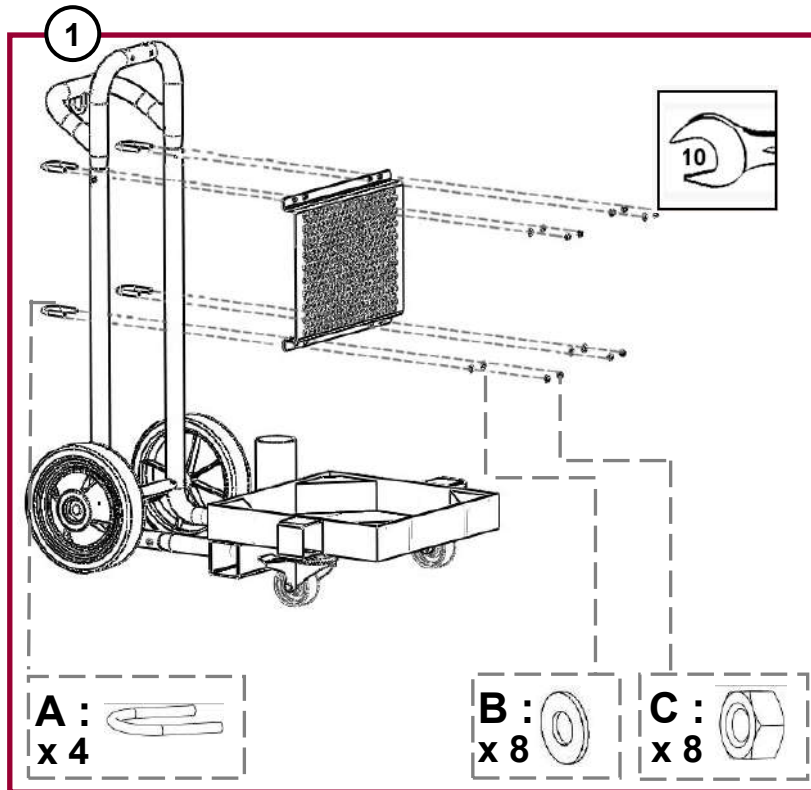

ASSEMBLAGE ASSEMBLY Trépied / Tripod

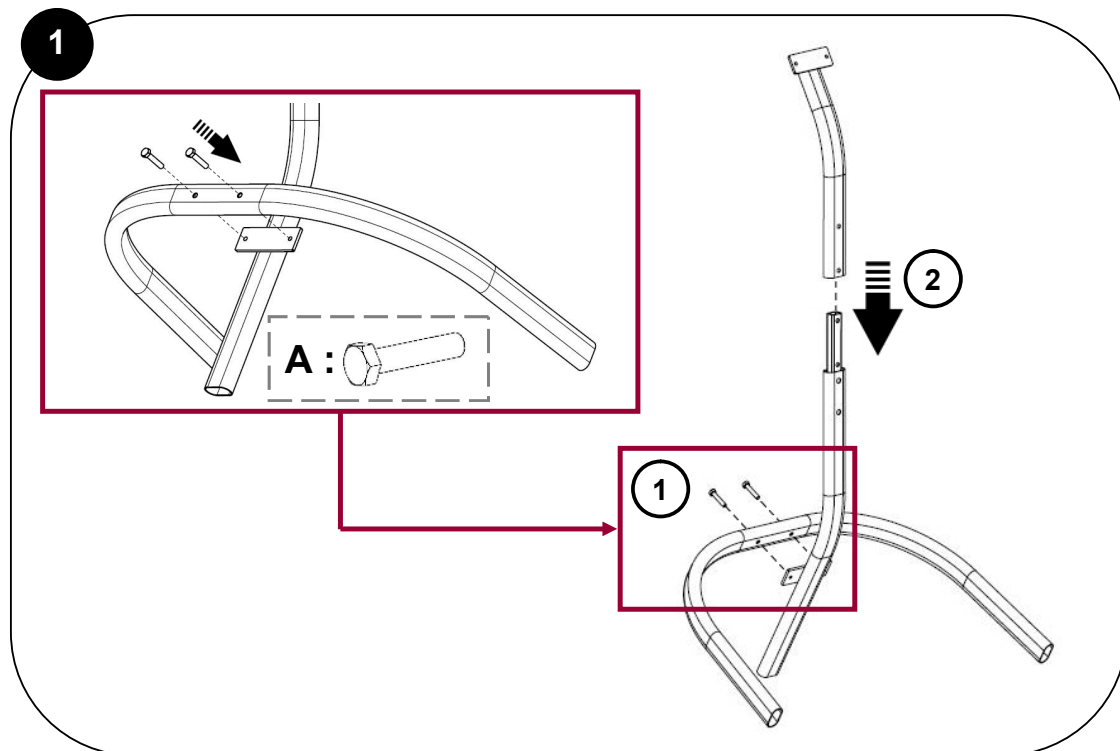
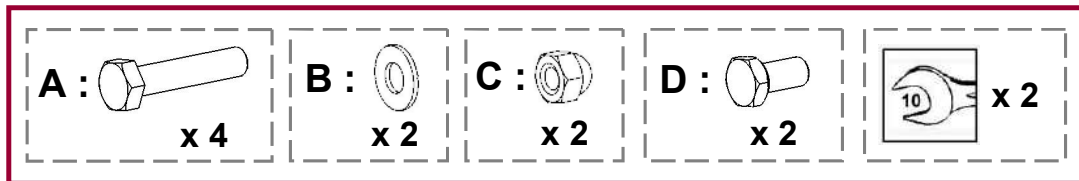
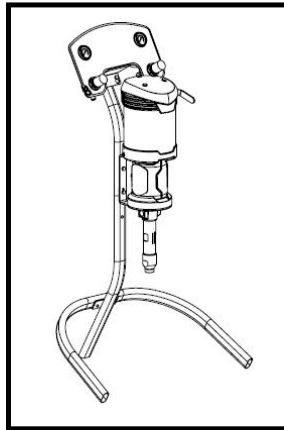

2

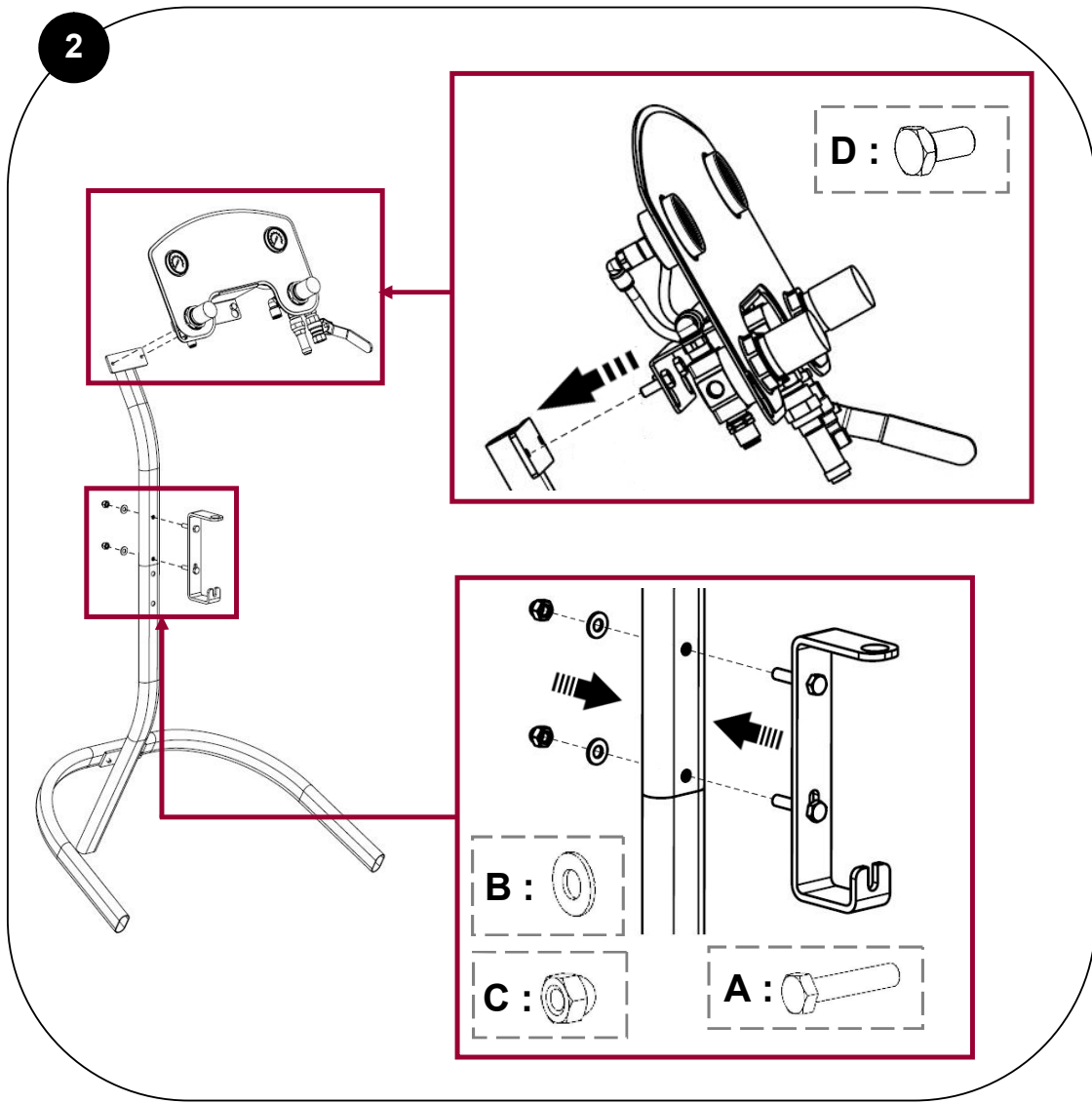

3

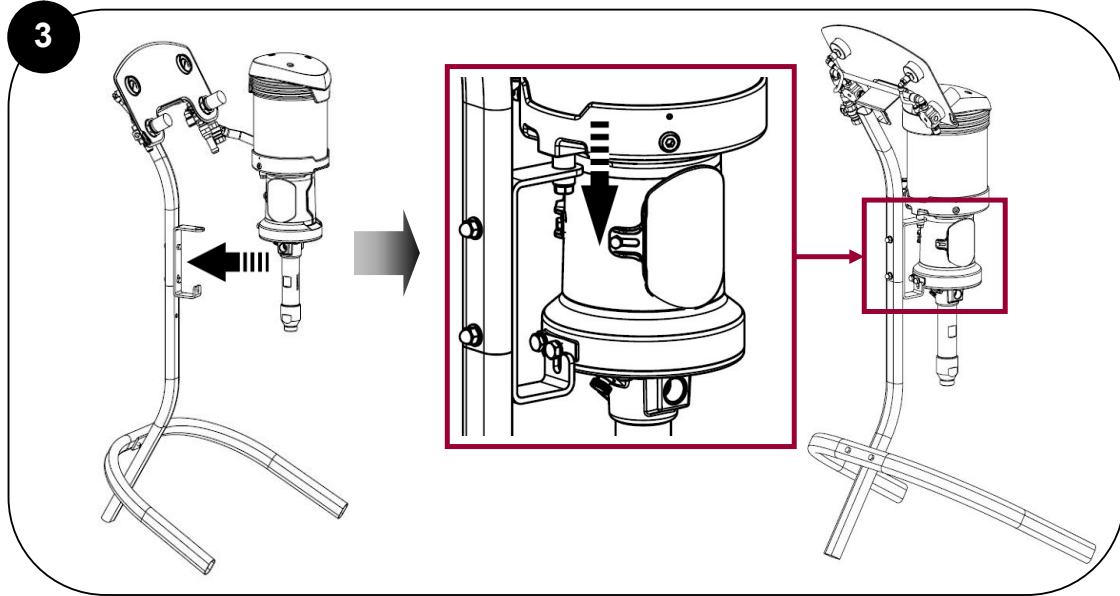

4

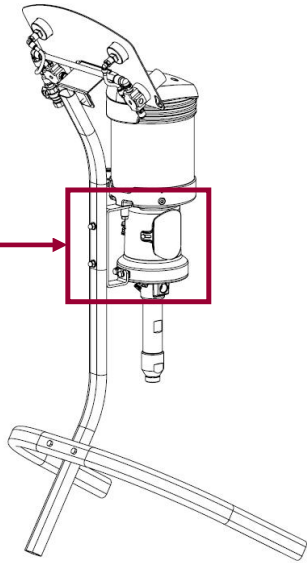

ASSEMBLAGE ASSEMBLY

Totem

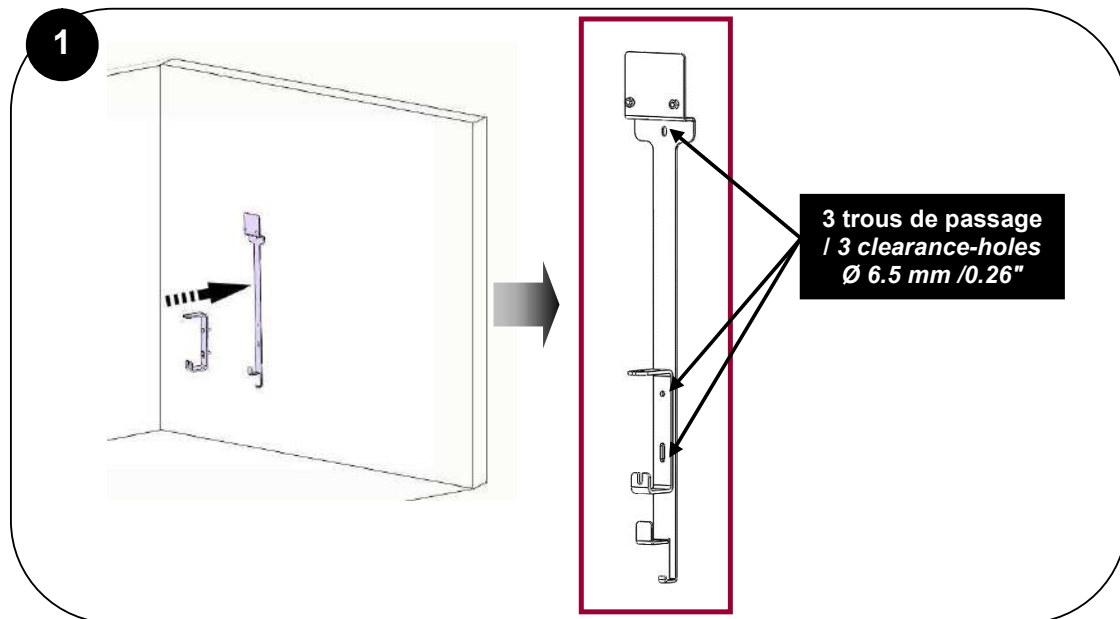
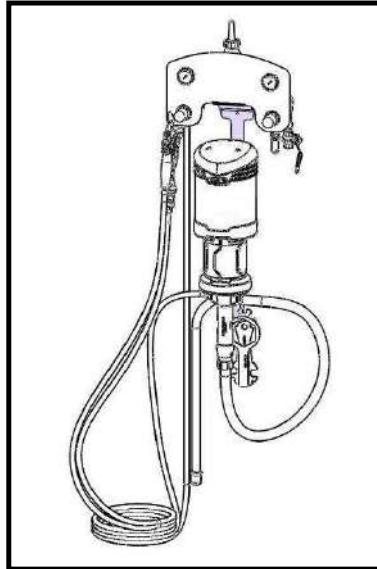

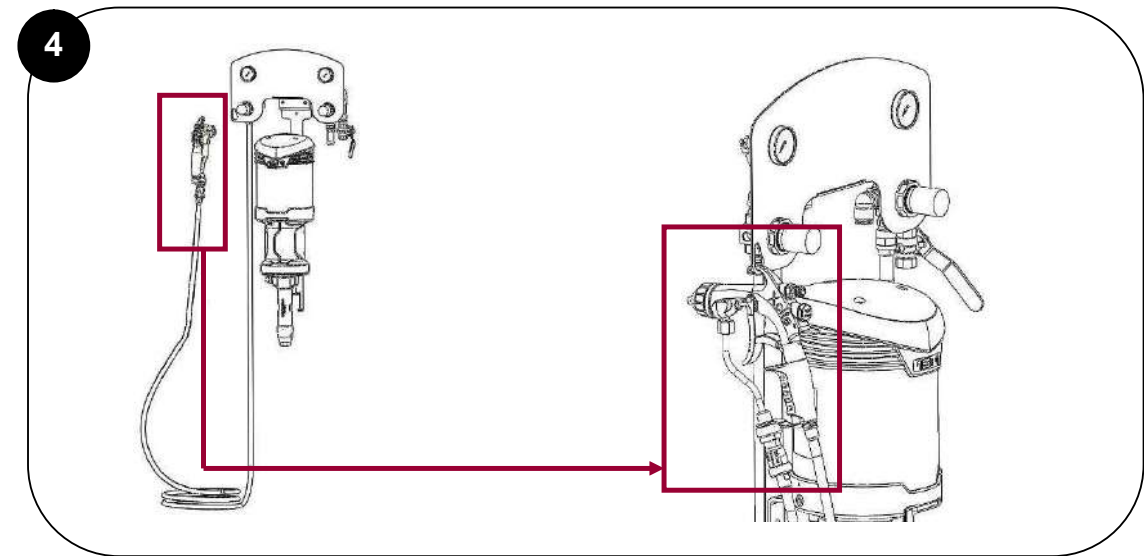
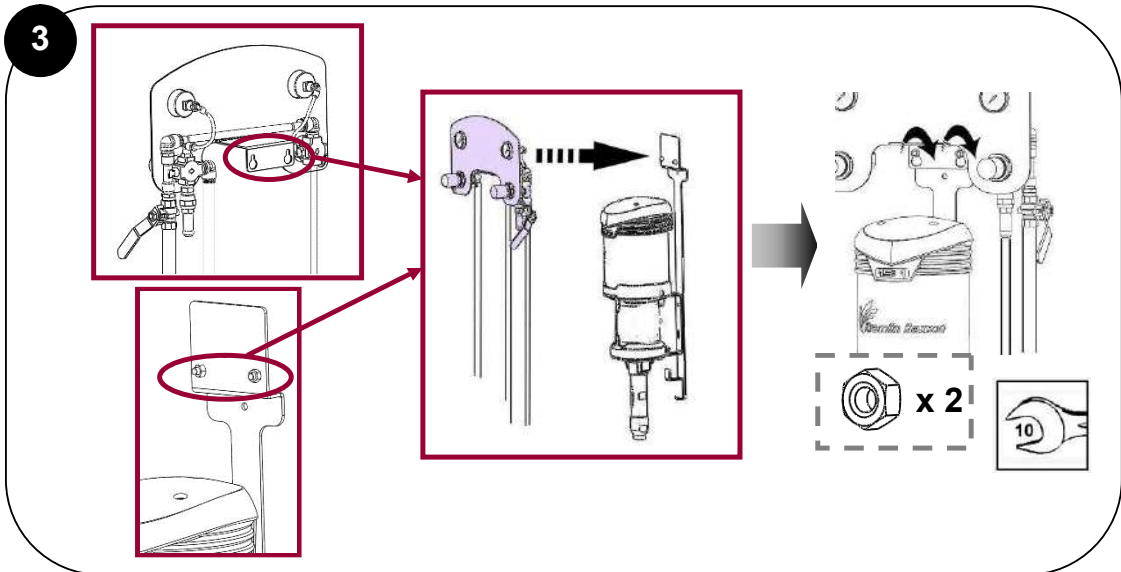
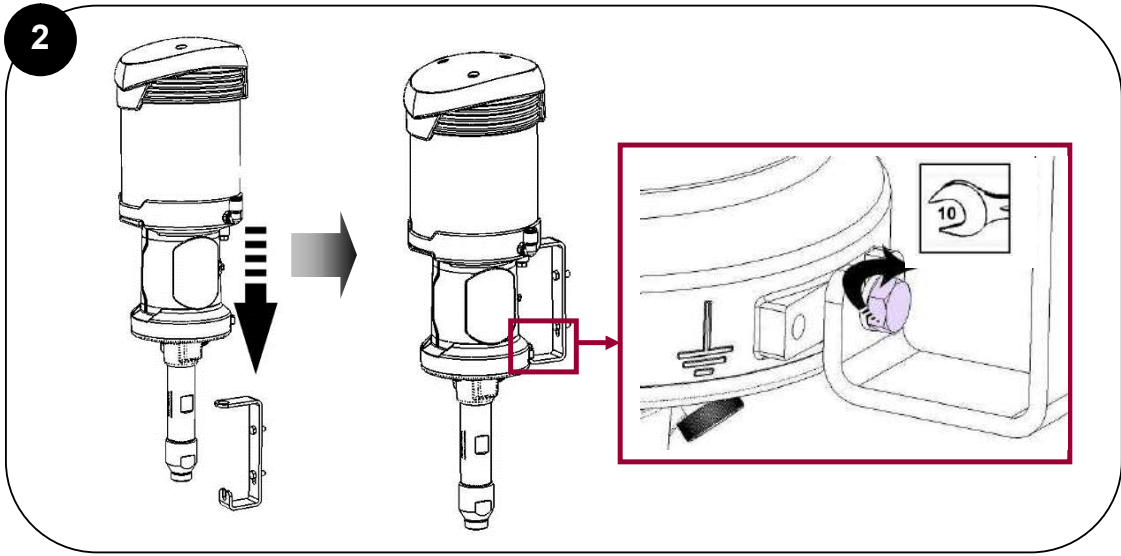

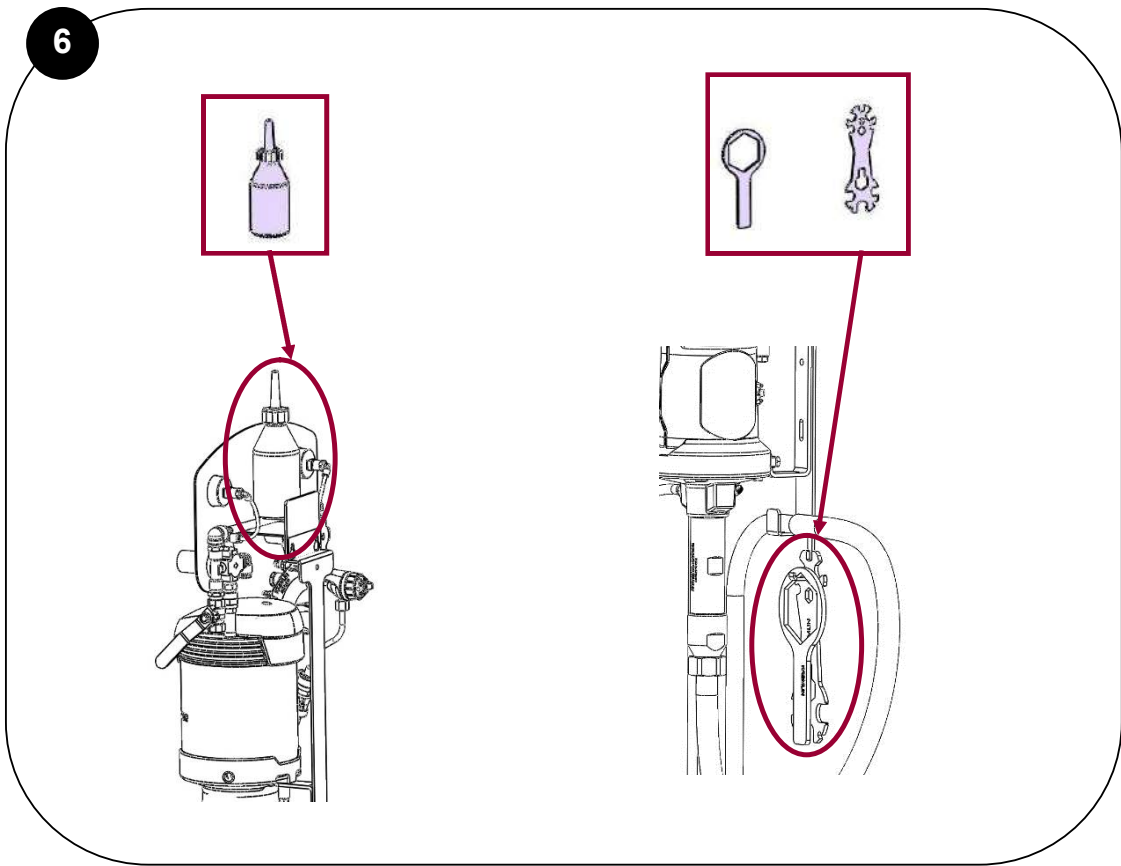
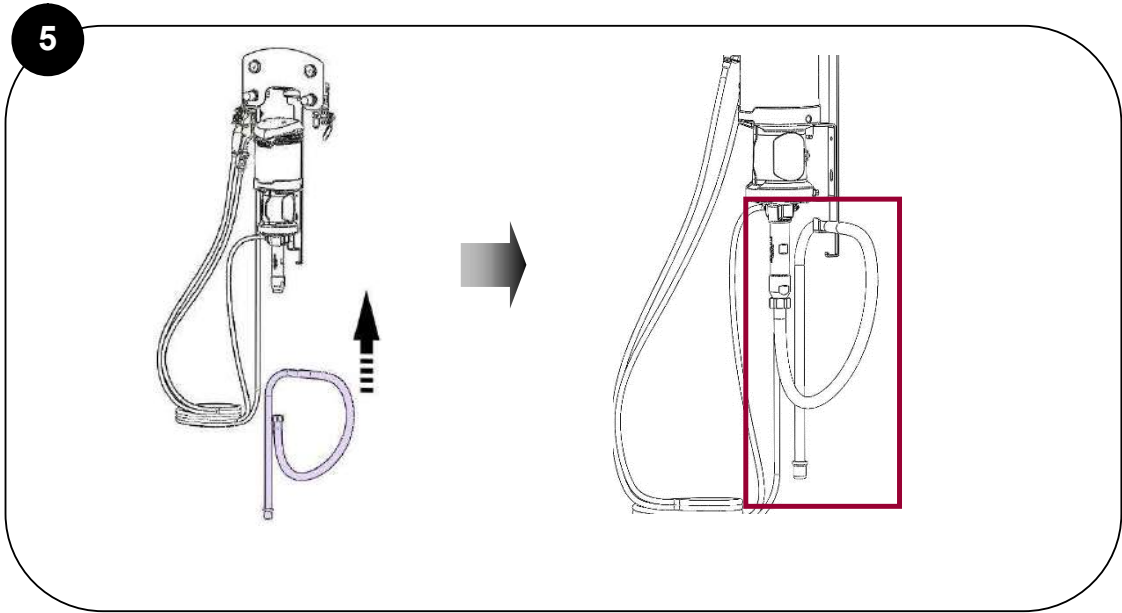

C-50

	#
ENSEMBLE CARTOUCHE GT/ GT CARTRIDGE ASSEMBLY / PACKUNG KOMPLETT GT / CARTUCHO EQUIPADO GT	144.135.205
ENSEMBLE PISTON JOINT GT / PISTON ASSEMBLY GT SEAL / KOLBEN KOMPLETT GT-DICHTUNG / CONJUNTO PISTÓN JUNTA GT	144.135.293
ENSEMBLE CARTOUCHE GT & PISTON / GT CARTRIDGE & PISTON ASSEMBLY / PACKUNG GT UND KOLBEN KOMPLETT / CONJUNTO CARTUCHO GT Y PISTÓN	144.135.291
ENSEMBLE PISTON & FLAMME / PISTON & TOOL ASSEMBLY / KOLBEN & WERKZEUG KOMPLETT / CONJUNTO PISTÓN & HERRAMIENTA	144.135.203
ENSEMBLE CARTOUCHE MB-A / MB-A CARTRIDGE ASSEMBLY / PACKUNG KOMPLETT MB-A / CARTUCHO EQUIPADO MB-A	144.135.305
ENSEMBLE CARTOUCHE MB-A & PISTON / MB-A CARTRIDGE & PISTON ASSEMBLY / PACKUNG MB-A UND KOLBEN KOMPLETT / CONJUNTO CARTUCHO MB-A Y PISTÓN	144.135.389
KIT OUTILS / TOOL KIT / WERKZEUGSATZ / KIT HERRAMINETA	144.135.297

NOTICE ORIGINALE
/ TRANSLATION FROM THE ORIGINAL MANUAL
/ ÜBERSETZUNG DER ORIGINAL BETRIEBSANLEITUNG
/ TRADUCCIÓN DEL LIBRO ORIGINAL

NOTA : Si le piston est endommagé, le remplacement de ce dernier implique le remplacement systématique de la cartouche.



NOTA : If the piston is damaged, you must change at the same time the cartridge.

ANMERKUNG: Wenn der Kolben beschädigt ist, müssen Sie gleichzeitig den Kolben und die Packung ersetzen.

NOTA : Si el pistón tiene un desgaste, su cambio llega al cambio del cartucho.

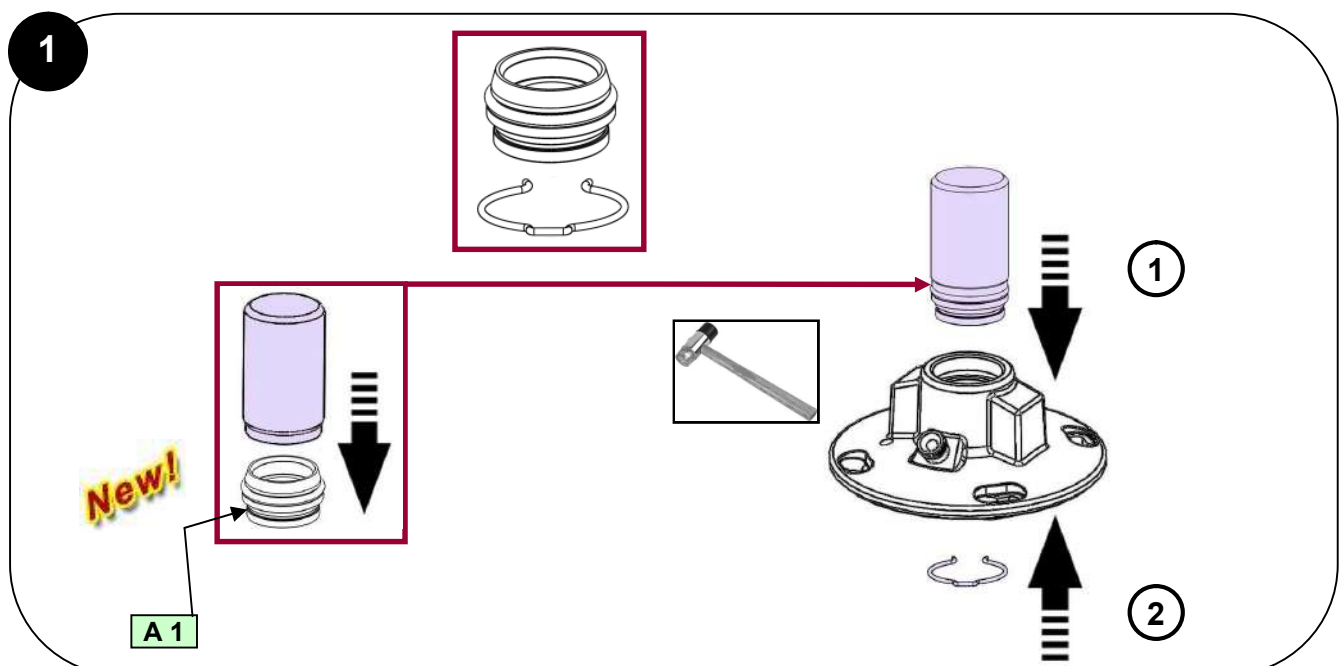

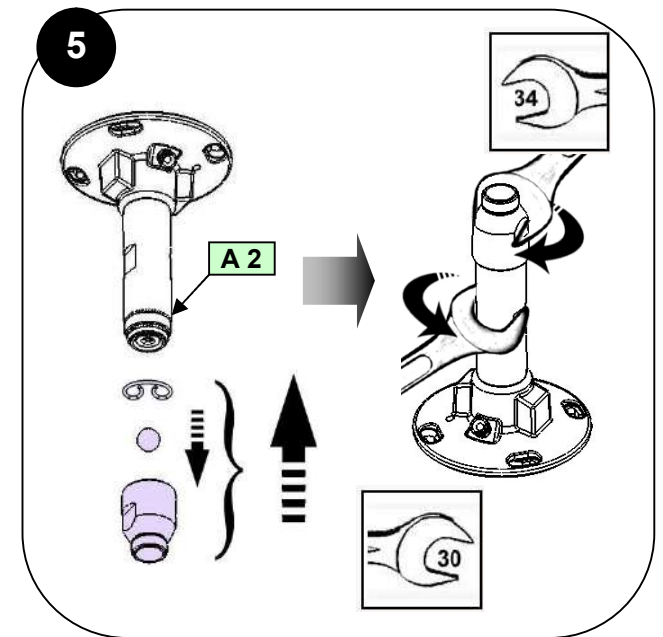
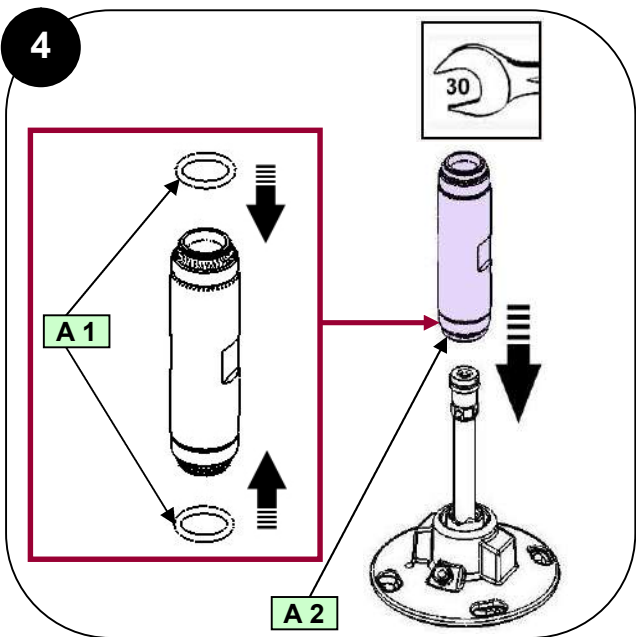
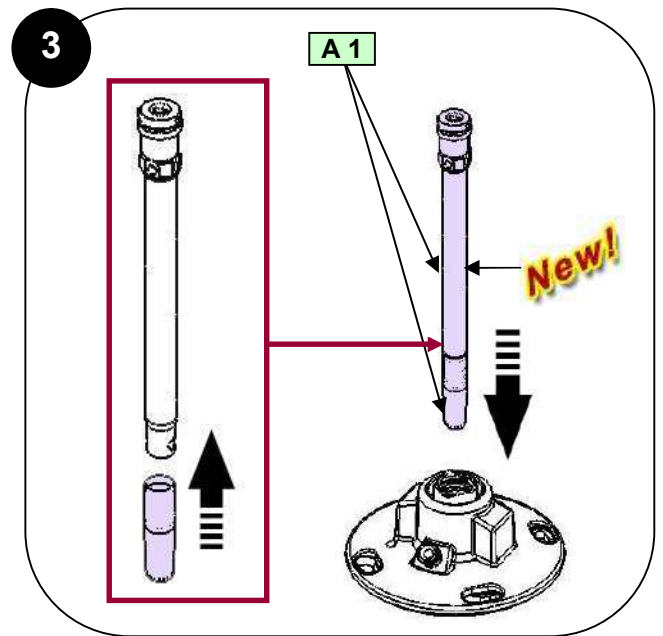
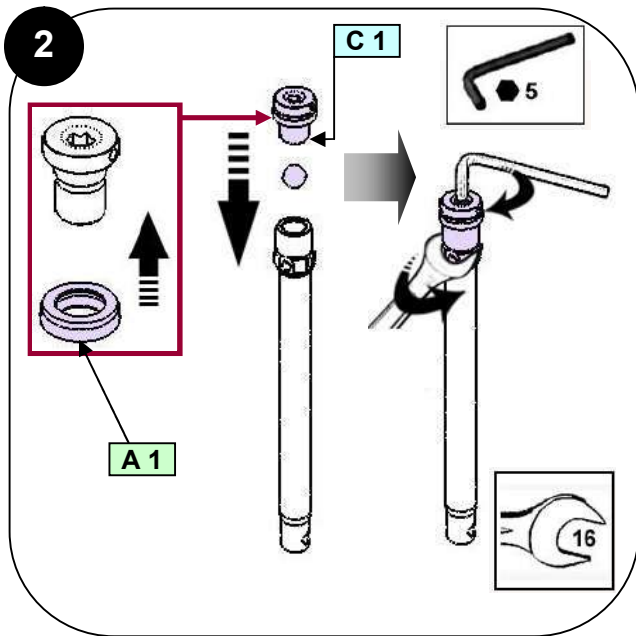

Repère / Index / Pos. / Índice	Instructions / Montage-Hinweis / Instrucciones	Désignation / Description / Bezeichnung / Descripción	Référence / Part number / Artikel-Nr. / Referencia
A 1	Graisse PTFE	Tube de graisse "TECHNILUB" (10 ml)	560.440.101
	PTFE grease	PTFE grease (10 ml / 0.0026 US gal)	
	PTFE-Fett	PTFE Fett (10 ml)	
	Grasa PTFE	Tubo de grasa "TECHNILUB" (10 ml)	
A 2	Graisse anti-seize	Boîte de graisse (450 g)	560.420.005
	Anti-seize grease	Grease box (450 g / 0.99 lb)	
	Grafit Fett	Grafit Fett (450 g Dose)	
	Grasa anti-seize	Caja de grasa anti-seize (450 g)	
C 1	Colle Anaérobie Tube étanche	Loctite 5772 (50 ml)	554.180.015
	Medium strength Aneorobic Pipe sealant	Loctite 5772 (50 ml / 0.013 US gal)	
	Mittelfester anaerober Kleber	Loctite 5772 (50 ml)	
	Cola PTFE (para la estanqueidad)	Loctite 5772 (50 ml)	

<p>Doc. 573.475.050 Date/Datum/Fecha : 01/02/18 Annule/Cancel/ Ersetzt/Anula : 14/12/17</p>	<p>Modif. / Änderung : EOS supprimé / canceled / annulliert / suprimido + Ind./ Pos. 30 (#151 240 000) supprimé / canceled / annulliert / suprimido + Ind./ Pos. 30a & 30b (#151 241 000, 151 242 000) + # 151 143 600</p>	<p>Pièces de rechange Spare parts list Ersatzteilliste Piezas de repuesto</p>
---	---	--

<p>POMPE, modèle 15C50</p>	<p>PUMP, model 15C50</p>
<p>PUMPE, Modell 15C50</p>	<p>BOMBA, tipo 15C50</p>

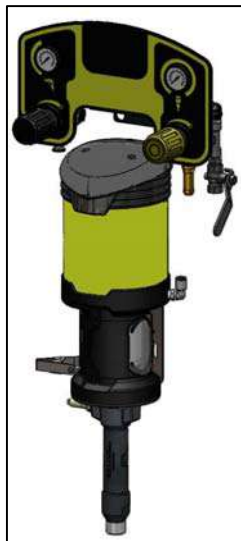

AIRMIX



AIRLESS

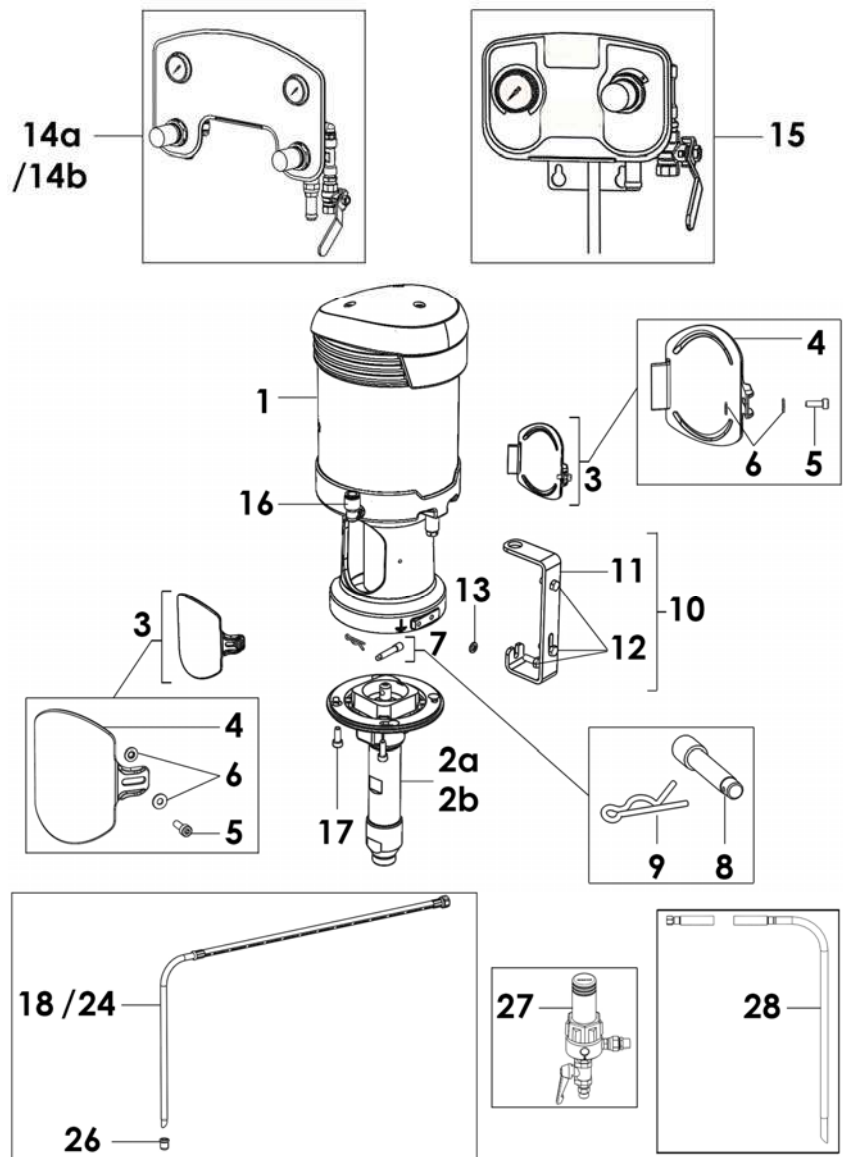

POMPE MURALE AIRMIX®, modèle 15C50 sans canne d'aspiration sans filtre produit (Entrée produit F 1/2 G)	AIRMIX® WALL MOUNTED PUMP, model 15C50 without suction rod without fluid filter (Material inlet F 1/2 G)	#
WANDANLAGE AIRMIX®, Modell 15C50 ohne Saugschlauch ohne Filter (Materialeingang IG 1/2" G)	BOMBA MURAL AIRMIX®, tipo 15C50 sin caña de aspiración sin filtro producto (Entrada producto H 1/2 G)	151.143.000
POMPE MURALE AIRMIX®, modèle 15C50 sans canne d'aspiration sans filtre produit (Entrée produit M 26x125)	AIRMIX® WALL MOUNTED PUMP, model 15C50 without suction rod without fluid filter (Material inlet M 26x125)	#
WANDANLAGE AIRMIX®, Modell 15C50 ohne Saugschlauch ohne Filter (Materialeingang M 26x1,25 AG)	BOMBA MURAL AIRMIX®, tipo 15C50 sin caña de aspiración sin filtro producto (Entrada producto M 26x125)	151.143.050
POMPE MURALE AIRLESS®, modèle 15C50 sans canne d'aspiration sans filtre produit (Entrée produit F 1/2 G)	AIRLESS WALL MOUNTED PUMP, model 15C50 without suction rod without fluid filter (Material inlet F 1/2 G)	#
WANDANLAGE AIRLESS®, Modell 15C50 ohne Saugschlauch ohne Filter (Materialeingang IG 1/2" G)	BOMBA MURAL AIRLESS®, tipo 15C50 sin caña de aspiración sin filtro producto (Entrada producto H 1/2 G)	151.143.500

Pièces communes - Common parts - Gleiche Teile - Partes comunes

Ind	#	Désignation	Description	Bezeichnung	Denominación	Qté
-	-	Pompe nue inox	Bare pump, stainless steel	Pumpe nackt, Edelstahl	Bomba sola de inox	1
1	NC / NS	▪ Moteur 420-4 (voir Doc. 573.435.050)	▪ Air motor, model 420-4 (refer to Doc. 573.435.050)	▪ Luftmotor, Modell 420-4 (Siehe Dok. 573.435.050)	▪ Motor, tipo 420-4 (Consultar Doc. 573.435.050)	1
*3	144 130 013	▪ Kit cache accouplement	▪ Coupling housing kit	▪ Schutzdeckelkit	▪ Kit cárter de acoplamiento	1
4	NC / NS	• Cache accouplement	• Coupling housing	• Schutzdeckel	• Cárter de acoplamiento	2
5	NC / NS	• Vis	• Screw	• Schraube	• Tornillo	2
6	NC / NS	• Rondelle	• Washer	• Mutter	• Arandela	4
*7	144 130 019	▪ Kit accouplement	▪ Coupling kit	▪ Kupplungskit	▪ Kit de acoplamiento	1
8	NC / NS	• Axe	• Axe	• Achse	• Eje	1
9	NC / NS	• Goupille	• Pin	• Splint	• Pasador	2
*10	144 130 022	▪ Support mural	▪ Pump bracket	▪ Wandhalterung, kpl.	▪ Soporte de bomba	1
11	NC / NS	• Support mural	• Pump bracket	• Wandhalter	• Soporte de bomba	1
12	NC / NS	• Vis H 6x16	• Screw, model H 6x16	• Schraube, H 6x16	• Tornillo, tipo H 6x16	3
13	NC / NS	• Rondelle AZ6	• Washer, model AZ6	• Mutter, AZ6	• Arandela, tipo AZ6	1
-	144 130 195	Kit écrous, vis et tirants	Nuts, screws and tie-rods kit	Stehbolzen, Schraube und Mutter	Kit tuercas, tornillos y tirantes	1
-	NC / NS	▪ Erou	▪ Nut	▪ Mutter	▪ Tuerca	4
-	NC / NS	▪ Vis	▪ Screw	▪ Schraube	▪ Tornillo	8
-	NC / NS	▪ Tirant	▪ Tie-rod, connecting	▪ Stehbolzen	▪ Tirante	4
16	905 120 913	Raccord coudé 1/4G - T 8x10	Elbow connector 1/4G - T 8x10	Winkel Stecknippel 1/4G - T 8x10	Racor acodado 1/4G - T 8x10	1
17	NC / NS	Vis CHc 6x16	Screw, model CHc 6x16	Schraube CHc 6x16	Tornillo, tipo CHc 6x16	4

Pièces spécifiques - Specific parts - Spezifische Teile - Partes específicas

Mod. 15C50 AIRMIX® (M 26x125 / M 26x1,25 AG)

Ind	#	Désignation	Description	Bezeichnung	Denominación	Qté
*2a	144 135 250	▪ Hydraulique C50 (Entrée produit M 26x125) (voir Doc. 573.474.050)	▪ Fluid section, model C50 (Material inlet M 26x125) (refer to Doc. 573.474.050)	▪ Hydraulikteil, Modell C50 (Materialeingang M 26x1,25 AG) (Siehe Dok. 573.474.050)	▪ Hidráulica, tipo C50 (Entrada producto M 26x125) (Consultar Doc. 573.474.050)	1
*14a	NC / NS	Equipement d'air (voir Doc. 573.436.050)	Air supply (refer to Doc. 573.436.050)	Luftausrüstung (Siehe Dok. 573.436.050)	Equipo de aire (consultar Doc. 573.436.050)	1
*14b	151 140 070	Equipement d'air (voir Doc. 573.436.050)	Air supply (refer to Doc. 573.436.050)	Luftausrüstung (Siehe Dok. 573.436.050)	Equipo de aire (consultar Doc. 573.436.050)	1

Mod. 15C50 AIRMIX® (F 1/2 G / IG 1/2" G / H 1/2 G)

Ind	#	Désignation	Description	Bezeichnung	Denominación	Qté
*2b	144 135 200	▪ Hydraulique C50 (Entrée produit F 1/2 G) (voir Doc. 573.474.050)	▪ Fluid section, model C50 (Material inlet F 1/2 G) (refer to Doc. 573.474.050)	▪ Hydraulikteil, Modell C50 (Materialeingang IG 1/2 G) (Siehe Dok. 573.474.050)	▪ Hidráulica, tipo C50 (Entrada producto H 1/2 G) (Consultar Doc. 573.474.050)	1
*14a	NC / NS	Equipement d'air (voir Doc. 573.436.050)	Air supply (refer to Doc. 573.436.050)	Luftausrüstung (Siehe Dok. 573.436.050)	Equipo de aire (consultar Doc. 573.436.050)	1
*14b	151 140 070	Equipement d'air (voir Doc. 573.436.050)	Air supply (refer to Doc. 573.436.050)	Luftausrüstung (Siehe Dok. 573.436.050)	Equipo de aire (consultar Doc. 573.436.050)	1

Mod. 15C50 AIRLESS (F 1/2 G / IG 1/2" G / H 1/2 G)

Ind	#	Désignation	Description	Bezeichnung	Denominación	Qté
*2b	144 135 200	▪ Hydraulique C50 (Entrée produit F 1/2 G) (voir Doc. 573.474.050)	▪ Fluid section, model C50 (Material inlet F 1/2 G) (refer to Doc. 573.474.050)	▪ Hydraulikteil, Modell C50 (Materialeingang IG 1/2 G) (Siehe Dok. 573.474.050)	▪ Hidráulica, tipo C50 (Entrada producto H 1/2 G) (Consultar Doc. 573.474.050)	1
*15	151 140 060	Equipement d'air (voir Doc. 573.436.050)	Air supply (refer to Doc. 573.436.050)	Luftausrüstung (Siehe Dok. 573.436.050)	Equipo de aire (consultar Doc. 573.436.050)	1

POMPE MURALE AIRMIX®, modèle 15C50 avec canne d'aspiration Ø 25 et filtre produit Ø 3/8" (Entrée produit M 26x125)	AIRMIX® WALL MOUNTED PUMP, model 15C50 with suction rod Ø 25 and fluid filter Ø 3/8" (Material inlet M 26x125)	#
WANDANLAGE AIRMIX®, Modell 15C50 mit Saugschlauch Ø 25 und Filter Ø 3/8" (Materialeingang M 26x1,25 AG)	BOMBA MURAL AIRMIX®, tipo 15C50 con caña de aspiración Ø 25 y filtro producto Ø 3/8" (Entrada producto M 26x125)	151.143.250

Ind	#	Désignation	Description	Bezeichnung	Denominación	Qté
-	151 143 050	Pompe murale Airmix® 15C50	Airmix® wall mounted pump, model 15C50	Airmix® Wandpumpe 15C50	Bomba mural Airmix®, tipo 15C50	1
18	149 596 150	Canne d'aspiration Ø 25	Suction rod Ø 25	Saugschlauch Ø 25	Caña de aspiración Ø 25	1
27	155 580 600	Filtre produit Ø 3/8" (voir Doc. 578.136.110)	Fluid filter, model Ø 3/8" (refer to Doc. 578.136.110)	Filter, Ø 3/8" (Siehe Dok. 578.136.110)	Filtro producto, tipo Ø 3/8" (consultar Doc. 578.136.110)	1
28	049 596 000	Canne de purge inox	Drain rod, st steel	Entleerungsrohr, Edelstahl	Caña de purga de inox	1

POMPE MURALE AIRMIX®, modèle 15C50 sans canne d'aspiration avec filtre produit Ø 3/8" (Entrée produit M 26x125)	AIRMIX® WALL MOUNTED PUMP, model 15C50 without suction rod with fluid filter Ø 3/8" (Material inlet M 26x125)	#
WANDANLAGE AIRMIX®, Modell 15C50 ohne Saugschlauch mit Filter Ø 3/8" Materialeingang M 26x1,25 AG)	BOMBA MURAL AIRMIX®, tipo 15C50 sin caña de aspiración con filtro producto Ø 3/8" (Entrada producto M 26x125)	151.143.450

Ind	#	Désignation	Description	Bezeichnung	Denominación	Qté
-	151 143 050	Pompe murale Airmix® 15C50	Airmix® wall mounted pump, model 15C50	Airmix® Wandpumpe 15C50	Bomba mural Airmix®, tipo 15C50	1
27	155 580 600	Filtre produit Ø 3/8" (voir Doc. 578.136.110)	Fluid filter, model Ø 3/8" (refer to Doc. 578.136.110)	Filter, Ø 3/8" (Siehe Dok. 578.136.110)	Filtro producto, tipo Ø 3/8" (consultar Doc. 578.136.110)	1
28	049 596 000	Canne de purge inox	Drain rod, st steel	Entleerungsrohr, Edelstahl	Caña de purga de inox	1

POMPE MURALE AIRMIX®, modèle 15C50 avec canne d'aspiration Ø 25 avec pistolet Airmix® Xcite - 120 bar avec raccord tournant (Entrée produit M 26x125)	AIRMIX® WALL MOUNTED PUMP, model 15C50 with suction rod Ø 25 with Airmix® Xcite gun - 120 bar /1740 psi with swivel fitting (Material inlet M 26x125)	# 151.265.050
WANDANLAGE AIRMIX®, Modell 15C50 mit Saugschlauch Ø 25 und Pistole Airmix® Xcite - 120 bar mit Drehgelenk (Materialeingang M 26x1,25 AG)	BOMBA MURAL AIRMIX®, tipo 15C50 con caña de aspiración Ø 25 y pistola Airmix® Xcite - 120 bar con racor giratorio (Entrada producto M 26x125)	

Ind	#	Désignation	Description	Bezeichnung	Denominación	Qté
-	151 143 050	Pompe murale Airmix® 15C50	Airmix® wall mounted pump, model 15C50	Airmix® Wandpumpe 15C50	Bomba mural Airmix®, tipo 15C50	1
-	050 382 114	Tuyau air (Ø 6,5x13 mm - Lg. 7,5 m - F 1/4 NPS)	Air hose (Ø 6.5x13 mm - 7,5 m / 24.6 ft length - F 1/4 NPS)	Luftschlauch (Ø 6,5x13mm - Länge 7,5m - IG 1/4 NPS)	Tubería de aire (Ø 6,5x13 mm - Longitud 7,5m - H 1/4 NPS)	1
-	050 450 853	Tuyau AIRMIX® (Ø 4,8 mm - 1/2 JIC - Lg. 7,5 m - 120 bar)	AIRMIX® hose (Ø 4,8 mm / 3/16" - 1/2 JIC - 7,5 m / 24.6 ft length - 120 bar / 1740 psi)	AIRMIX® - Schlauch (Ø 4,8 mm - 1/2 JIC - Länge 7,5 m - 120 bar)	Tubería AIRMIX® (Ø 4,8 mm - 1/2 JIC - Longitud 7,5 m - 120 bar)	1
-	129 270 087	Enveloppe de protection des tuyaux (lg. 10 m)	Protective hose sleeving (10 m / 33 ft long)	Schutzhülle für Schlauch (Länge 10 m)	Funda de protección de las tuberías (10 m de largo)	1
18	149 596 150	Canne d'aspiration Ø 25	Suction rod Ø 25	Saugschlauch Ø 25	Caña de aspiración Ø 25	1
-	135 720 120	Pistolet Xcite 120 bar sans raccord tournant (voir Doc. 573.512.050)	Xcite gun, model 120 bar / 1740 psi without swivel fitting (refer to Doc. 573.512.050)	Pistole Xcite, 120 bar ohne Drehgelenk (Siehe Dok. 573.512.050)	Pistola Xcite 120 bar sin racor giratorio (consultar Doc. 573.512.050)	1
-	129 670 425	Raccord tournant 500 bar M 1/2 JIC - F 1/2 JIC	Swivel fitting 500 bar / 7250 psi M 1/2 JIC - F 1/2 JIC	Drehgelenk 500 bar AG 1/2 JIC - IG 1/2 JIC	Racor giratorio 500 bar M 1/2 JIC - H 1/2 JIC	1

POMPE MURALE AIRMIX®, modèle 15C50 avec canne d'aspiration avec filtre produit Ø 3/8" avec pistolet Airmix® Xcite - 120 bar avec raccord tournant (Entrée produit M 26x125)	AIRMIX® WALL MOUNTED PUMP, model 15C50 with suction rod with fluid filter Ø 3/8" with Airmix® Xcite gun - 120 bar /1740 psi with swivel fitting (Material inlet M 26x125)	#
WANDANLAGE AIRMIX®, Modell 15C50 mit Saugschlauch mit Filter Ø 3/8" und Pistole Airmix® Xcite - 120 bar mit Drehgelenk Materialeingang M 26x1,25 AG)	BOMBA MURAL AIRMIX®, tipo 15C50 con caña de aspiración con filtro producto Ø 3/8" y pistola Airmix® Xcite - 120 bar con racor giratorio (Entrada producto M 26x125)	151.265.053

Ind	#	Désignation	Description	Bezeichnung	Denominación	Qté
-	151 143 050	Pompe murale Airmix® 15C50	Airmix® wall mounted pump, model 15C50	Airmix® Wandpumpe 15C50	Bomba mural Airmix®, tipo 15C50	1
18	149 596 150	Canne d'aspiration Ø 25	Suction rod Ø 25	Saugschlauch Ø 25	Caña de aspiración Ø 25	1
27	155 580 600	Filtre produit Ø 3/8" (voir Doc. 578.136.110)	Fluid filter, model Ø 3/8" (refer to Doc. 578.136.110)	Filter, Ø 3/8" (Siehe Dok. 578.136.110)	Filtro producto, tipo Ø 3/8" (consultar Doc. 578.136.110)	1
-	050 382 114	Tuyau air (Ø 6,5x13 mm - Lg. 7,5 m - F 1/4 NPS)	Air hose (Ø 6.5x13 mm - 7,5 m / 24.6 ft length - F 1/4 NPS)	Luftschlauch (Ø 6,5x13mm - Länge 7,5m - IG 1/4 NPS)	Tubería de aire (Ø 6,5x13 mm - Longitud 7,5m - H 1/4 NPS)	1
-	050 450 853	Tuyau AIRMIX® (Ø 4,8 mm - 1/2 JIC - Lg. 7,5 m - 120 bar)	AIRMIX® hose (Ø 4,8 mm / 3/16" - 1/2 JIC - 7,5 m / 24.6 ft length - 120 bar / 1740 psi)	AIRMIX® - Schlauch (Ø 4,8 mm - 1/2 JIC - Länge 7,5 m - 120 bar)	Tubería AIRMIX® (Ø 4,8 mm - 1/2 JIC - Longitud 7,5 m - 120 bar)	1
-	129 270 087	Enveloppe de protection des tuyaux (lg. 10 m)	Protective hose sleeving (10 m / 33 ft long)	Schutzhülle für Schlauch (Länge 10 m)	Funda de protección de las tuberías (10 m de largo)	1
-	135 720 120	Pistolet Xcite 120 bar sans raccord tournant (voir Doc. 573.512.050)	Xcite gun, model 120 bar / 1740 psi without swivel fitting (refer to Doc. 573.512.050)	Pistole Xcite, 120 bar ohne Drehgelenk (Siehe Dok. 573.512.050)	Pistola Xcite 120 bar sin racor giratorio (consultar Doc. 573.512.050)	1
-	129 670 425	Raccord tournant 500 bar M 1/2 JIC - F 1/2 JIC	Swivel fitting 500 bar / 7250 psi M 1/2 JIC - F 1/2 JIC	Drehgelenk 500 bar AG 1/2 JIC - IG 1/2 JIC	Racor giratorio 500 bar M 1/2 JIC - H 1/2 JIC	1

POMPE MURALE AIRMIX®, modèle 15C50 avec canne d'aspiration avec filtre produit Ø 3/8" avec pistolet Airmix® Xcite - 120 bar avec raccord tournant avec réchauffeur (Entrée produit M 26x125)	AIRMIX® WALL MOUNTED PUMP, model 15C50 with suction rod with fluid filter Ø 3/8" with Airmix® Xcite gun - 120 bar /1740 psi with swivel fitting with heater (Material inlet M 26x125)	#
WANDANLAGE AIRMIX®, Modell 15C50 mit Saugschlauch mit Filter Ø 3/8" und Pistole Airmix® Xcite - 120 bar mit Drehgelenk mit erhitzer Materialeingang M 26x1,25 AG)	BOMBA MURAL AIRMIX®, tipo 15C50 con caña de aspiración con filtro producto Ø 3/8" y pistola Airmix® Xcite - 120 bar con racor giratorio con calefactor (Entrada producto M 26x125)	151.265.055

Ind	#	Désignation	Description	Bezeichnung	Denominación	Qté
-	151 143 050	Pompe murale Airmix® 15C50	Airmix® wall mounted pump, model 15C50	Airmix® Wandpumpe 15C50	Bomba mural Airmix®, tipo 15C50	1
18	149 596 150	Canne d'aspiration Ø 25	Suction rod Ø 25	Saugschlauch Ø 25	Caña de aspiración Ø 25	1
27	155 580 600	Filtre produit Ø 3/8" (voir Doc. 578.136.110)	Fluid filter, model Ø 3/8" (refer to Doc. 578.136.110)	Filter, Ø 3/8" (Siehe Dok. 578.136.110)	Filtro producto, tipo Ø 3/8" (consultar Doc. 578.136.110)	1
-	050 382 114	Tuyau air (Ø 6,5x13 mm - Lg. 7,5 m - F 1/4 NPS)	Air hose (Ø 6.5x13 mm - 7,5 m / 24.6 ft length - F 1/4 NPS)	Luftschlauch (Ø 6,5x13mm - Länge 7,5m - IG 1/4 NPS)	Tubería de aire (Ø 6,5x13 mm - Longitud 7,5m - H 1/4 NPS)	1
-	050 450 853	Tuyau AIRMIX® (Ø 4,8 mm - 1/2 JIC - Lg. 7,5 m - 120 bar)	AIRMIX® hose (Ø 4,8 mm / 3/16" - 1/2 JIC - 7,5 m / 24.6 ft length - 120 bar / 1740 psi)	AIRMIX® - Schlauch (Ø 4,8 mm - 1/2 JIC - Länge 7,5 m - 120 bar)	Tubería AIRMIX® (Ø 4,8 mm - 1/2 JIC - Longitud 7,5 m - 120 bar)	1
-	050 450 651	Tuyau (Ø 4,8 mm - 1/2 JIC - Lg. 0,6 m - 240 bar)	Hose (Ø 4,8 mm / 3/16" - 1/2 JIC - 0.6 m / 2 ft length - 240 bar / 3527 psi)	Schlauch (Ø 4,8 mm - 1/2 JIC - Länge 0,6 m - 240 bar)	Tubería (Ø 4,8 mm - 1/2 JIC - Longitud 0,6 m - 240 bar)	
-	129 270 087	Enveloppe de protection des tuyaux (lg. 10 m)	Protective hose sleeving (10 m / 33 ft long)	Schutzhülle für Schlauch (Länge 10 m)	Funda de protección de las tuberías (10 m de largo)	1
-	135 720 120	Pistolet Xcite 120 bar sans raccord tournant (voir Doc. 573.512.050)	Xcite gun, model 120 bar / 1740 psi without swivel fitting (refer to Doc. 573.512.050)	Pistole Xcite, 120 bar ohne Drehgelenk (Siehe Dok. 573.512.050)	Pistola Xcite 120 bar sin racor giratorio (consultar Doc. 573.512.050)	1
-	056 126 000	Réchauffeur antidéflagrant (voir Doc. 573.168.050)	Explosion-proof heater (refer to Doc. 573.168.050)	Erhitzer ex-geschützt (Siehe Dok. 573.168.050)	Calefactor anitideflagrante (consultar Doc 573.168.050)	1
-	129 670 425	Raccord tournant 500 bar M 1/2 JIC - F 1/2 JIC	Swivel fitting 500 bar / 7250 psi M 1/2 JIC - F 1/2 JIC	Drehgelenk 500 bar AG 1/2 JIC - IG 1/2 JIC	Racor giratorio 500 bar M 1/2 JIC - H 1/2 JIC	1

POMPE MURALE AIRMIX®, modèle 15C50 avec canne d'aspiration avec filtre produit Ø 3/8" avec pistolet Airmix® Xcite Light - 120 bar avec buse (Entrée produit M 26x125)	AIRMIX® WALL MOUNTED PUMP, model 15C50 with suction rod with fluid filter Ø 3/8" with Airmix® Xcite Light gun - 120 bar /1740 psi with tip (Material inlet M 26x125)	#
WANDANLAGE AIRMIX®, Modell 15C50 mit Saugschlauch mit Filter Ø 3/8" und Pistole Airmix® Xcite Light - 120 bar mit Düse Materialeingang M 26x1,25 AG)	BOMBA MURAL AIRMIX®, tipo 15C50 con caña de aspiración con filtro producto Ø 3/8" y pistola Airmix® Xcite Light - 120 bar con boquilla (Entrada producto M 26x125)	151.143.600

Ind	#	Désignation	Description	Bezeichnung	Denominación	Qté
-	151 143 050	Pompe murale Airmix® 15C50	Airmix® wall mounted pump, model 15C50	Airmix® Wandpumpe 15C50	Bomba mural Airmix®, tipo 15C50	1
18	149 596 150	Canne d'aspiration Ø 25	Suction rod Ø 25	Saugschlauch Ø 25	Caña de aspiración Ø 25	1
27	155 580 600	Filtre produit Ø 3/8" (voir Doc. 578.136.110)	Fluid filter, model Ø 3/8" (refer to Doc. 578.136.110)	Filter, Ø 3/8" (Siehe Dok. 578.136.110)	Filtro producto, tipo Ø 3/8" (consultar Doc. 578.136.110)	1
-	050 382 114	Tuyau air (Ø 6,5x13 mm - Lg. 7,5 m - F 1/4 NPS)	Air hose (Ø 6.5x13 mm - 7,5 m / 24.6 ft length - F 1/4 NPS)	Luftschlauch (Ø 6,5x13mm - Länge 7,5m - IG 1/4 NPS)	Tubería de aire (Ø 6,5x13 mm - Longitud 7,5m - H 1/4 NPS)	1
-	050 450 855	Tuyau AIRMIX® (Ø 4,8 mm - 1/2 JIC - Lg. 6 m - 120 bar)	AIRMIX® hose (Ø 4,8 mm / 3/16" - 1/2 JIC - 6 m / 19.7 ft length - 120 bar / 1740 psi)	AIRMIX® - Schlauch (Ø 4,8 mm - 1/2 JIC - Länge 6 m - 120 bar)	Tubería AIRMIX® (Ø 4,8 mm - 1/2 JIC - Longitud 6 m - 120 bar)	1
-	050 451 051	Tuyau (Ø 3,2 mm - 1/2 JIC - Lg. 1,6 m - 120 bar)	Hose (Ø 3,2 mm / 3/16" - 1/2 JIC - 1,6 m / 5.25 ft length - 120 bar / 1740 psi)	Schlauch (Ø 3,2 mm - 1/2 JIC - Länge 1,6 m - 120 bar)	Tubería (Ø 3,2 mm - 1/2 JIC - Longitud 1,6 m - 120 bar)	1
-	129 270 087	Enveloppe de protection des tuyaux (lg. 10 m)	Protective hose sleeving (10 m / 33 ft long)	Schutzhülle für Schlauch (Länge 10 m)	Funda de protección de las tuberías (10 m de largo)	1
-	135 725 120	Pistolet Xcite Light 120 bar sans raccord tournant (voir Doc. 573.505.050)	Xcite Light gun, model 120 bar / 1740 psi without swivel fitting (refer to Doc. 573.505.050)	Pistole Xcite Light, 120 bar ohne Drehgelenk (Siehe Dok. 573.505.050)	Pistola Xcite Light 120 bar sin racor giratorio (consultar Doc. 573.505.050)	1
-	134 512 114	Buse	Tip	Düse	Boquilla	1

OPTIONS - ON REQUEST - OPTIONEN - OPCIONES

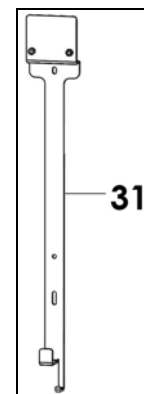
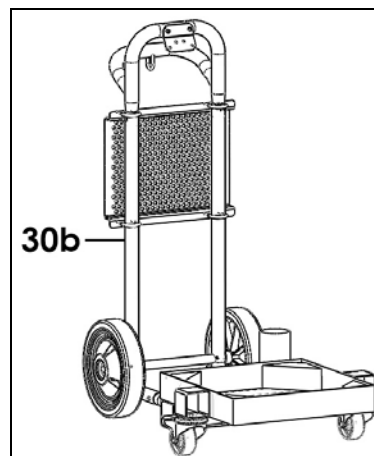
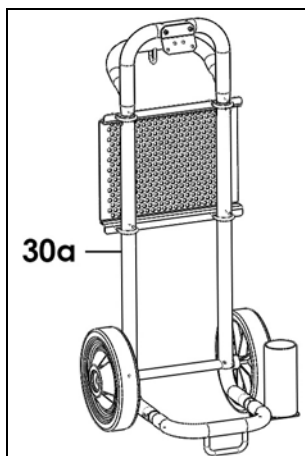
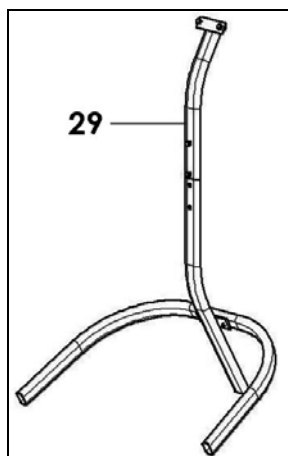

Ind	#	Désignation	Description	Bezeichnung	Denominación	Qté
24	149 596 160	Canne d'aspiration Ø 25 pour fût 200L	Suction rod Ø 25 for drum, model 200L	Saugschlauch Ø 25 für 200L Fass	Caña de aspiración Ø 25 para bidón de 200L	1
26	149 596 152	Crépine Ø 25	Strainer Ø 25	Siebkorb Ø 25	Piña Ø 25	1
-	149 596 059	Lot de 10 cannes d'aspiration Ø 16 - Lg. 600 mm	Pack of 10 suction rods, model Ø 16 - Length : 600 mm / 23.6"	Satz mit 10 Saugschläuchen, Ø 16 - Länge: 600mm	Bolsa de 10 cañas de aspiración, tipo Ø 16 - 600 mm de largo	1
-	149 596 159	Lot de 10 cannes d'aspiration Ø 25 - Lg. 600 mm	Pack of 10 suction rods, model Ø 25 - Length : 600 mm / 23.6"	Satz mit 10 Saugschläuchen, Ø 25 - Länge: 600mm	Bolsa de 10 cañas de aspiración, tipo Ø 25 - 600 mm de largo	1
29	151 140 210	Trépied (voir Doc.578.048.110)	Tripod (refer to Doc. 578.048.110)	Dreibein Gestell (Siehe Dok. 578.048.110)	Trepie (consultar Doc. 578.048.110)	1
30a	151 241 000	Chariot (voir Doc. 578.208.110)	Cart (refer to Doc. 578.208.110)	Fahrgestell (Siehe Dok. 578.208.110)	Carretilla (consultar Doc. 578.208.110)	1
30b	151 242 000	Chariot (voir Doc. 578.208.110)	Cart (refer to Doc. 578.208.110)	Fahrgestell (Siehe Dok. 578.208.110)	Carretilla (consultar Doc. 578.208.110)	1
31	151 140 240	Totem (voir Doc. 578.062.110)	Totem (refer to Doc. 578.062.110)	Aufhängung (Siehe Dok. 578.062.110)	Totem (consultar Doc. 578.062.110)	1

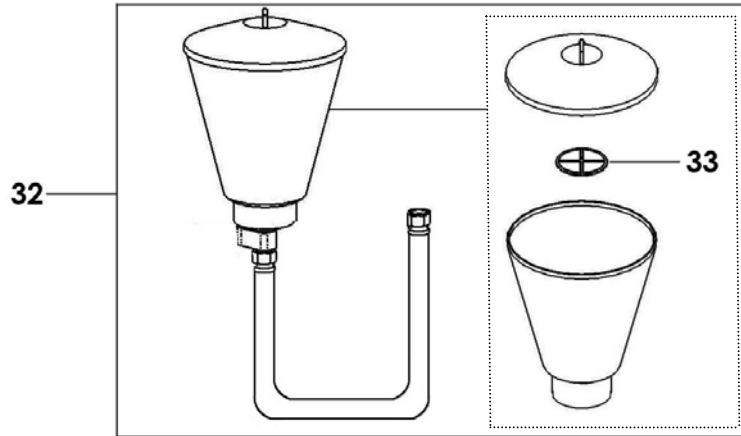

Ind	#	Désignation	Description	Bezeichnung	Denominación	Qté
32	151 140 230	Godet gravité 6 Litres	Gravity cup 6 Liter / 1.6 US gal	Zulaufbehälter 6 Liter	Bote de gravedad 6 Litros	1
-	NC / NS	▪ Godet	▪ Cup	▪ Behälter	▪ Bote	1
-	NC / NS	▪ Adaptateur U	▪ U adapter	▪ U-Verbindung	▪ Adaptador U	1
33	151 890 399	Tamis de rechange 18 MESH (pochette de 2)	Screen, 18 MESH (pack of 2)	Ersatzsieb, 18 MESH (2 St.)	Tamiz de recambio 18 MESH (Bolsa de 2)	1

ACCESSOIRES - ACCESSORIES - ZUBEHÖR - ACCESORIOS

Ind	#	Désignation	Description	Bezeichnung	Denominación	Qté
-	149 990 020	Flacon de lubrifiant T (125 ml)	T lubricant (125 ml / 4.4 oz)	Spülmittel T (125 ml)	Botella de lubricante T (125 ml)	1

* Pièces de maintenance préconisées.

* Preceding the index number denotes a suggested spare part.

* Bezeichnete Teile sind empfohlene Ersatzteile.

* Piezas de mantenimiento preventivas.

N C : Non commercialisé.

N S : Denotes parts are not serviceable.

N S : Bezeichnete Teile gibt es nicht einzeln, sondern nur komplett .

N S : no suministrado.

Doc. 573.435.050 Date/Datum/Fecha : 14/12/17 Annule/Cancel/ Ersetzt/Anula : 03/09/15	Modif. / Änderung : Kremlin Rexson → Sames Kremlin	Pièces de rechange Spare parts list Ersatzteilliste Piezas de repuesto
--	--	---

MOTEUR A AIR, modèle 245-4	AIR MOTOR, model 245-4
LUFTMOTOR, Modell 245-4	MOTOR DE AIRE, tipo 245-4

MOTEUR A AIR, modèle 420-4	AIR MOTOR, model 420-4
LUFTMOTOR, Modell 420-4	MOTOR DE AIRE, tipo 420-4

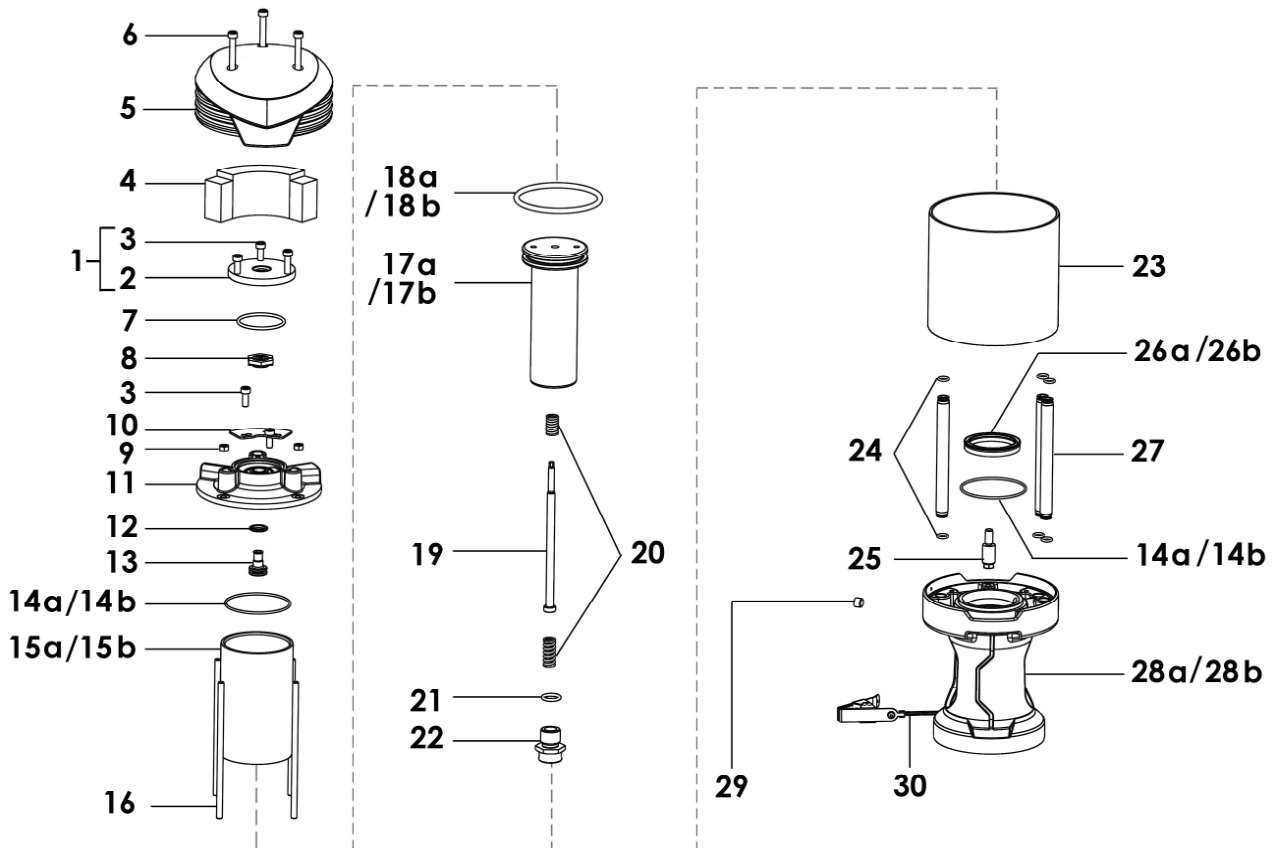



IMPORTANT : Respecter le **couple de serrage de 8 Nm maxi** sur les écrous (9).
Comply with the **maximum screwing torque of 8 Nm / 5.9 ft/lbs** on the nuts (9).
Das **maximale Anziehdrehmoment** für die Muttern (9) **beträgt 8 Nm**.
Cumplir con el par de apriete de **8 Nm maxi** en las tuercas (9).

Ind	#	Désignation	Description	Bezeichnung	Denominación	Qté
		Pièces communes aux moteurs 245-4 et 420-4	Common parts to the air motors, model 245-4 and 420-4	Gleiche Teile für Motore 245-4 und 420-4	Partes comunes de los motores, tipo 245-4 y 420-4	
*1	144 130 016	Couvercle équipé	Cover assembly	Deckel komplett	Tapa equipada	1
2	N C / N S	▪ Couvercle	▪ Cover	▪ Deckel	▪ Tapa	1
3	933 151 332	▪ Vis CHc 6x25	▪ Screw, model CHc 6x25	▪ Schraube CHc 6x25	▪ Tornillo, tipo CHc 6x25	5
4	144 130 011	Silencieux	Muffler	Schalldämpfer	Silenciador	1
*5	144 130 004	Cloche	Cover	Glocke	Campana	1
6	933 151 523	Vis CHc 6x45	Screw, model CHc 6x45	Schraube CHc 6x45	Tornillo, tipo CHc 6x45	3
7	909 420 220	Joint torique	Seal O-Ring,	O-Ring	Junta tórica	1
8	144 130 010	Clapet	Valve	Umsteuerventil	Válvula de aire	1
9	953 010 016	Ecrou HM6	Nut, model HM6	Mutter, HM6	Tuerca, tipo M6	4
10	144 130 024	Grille d'échappement	Exhaust grid	Abluftgitter	Cancela de escape	1
*11	144 130 003	Corps inverseur	Reversing body	Umschaltblock	Cuerpo inversor	1
12	909 210 501	Joint	Seal	Dichtring	Junta	1
13	144 130 008	Porte joint	Seal holder	O-Ring-Halter	Porta- junta	1
16	144 130 012	Tirant	Tie-rod	Bolzen	Tirante	4
19	144 130 006	Tige de commande assemblée	Control rod assembly	Steuerstange	Eje de mando equipado	1
*20	144 130 194	Ressort (par 2)	Spring (pack of 2)	Feder (2er Pack)	Muelle (x 2)	1
21	909 130 315	Joint torique R 13	Seal O-Ring, model R 13	Dichtring R 13	Junta tórica, tipo R 13	1
22	144 130 020	Vis accouplement	Coupling screw	Kupplungsschraube	Tornillo de acoplamiento	1
23	N C / N S	Virole	Muffler	Schallschutzhaube	Virola	1
24	000 940 120	Joint NBR noir	NBR seal (black)	Dichtring NBR (schwarz)	Junta NBR negra	6
25	144 130 023	Poignard	Pin	Stift	Eje	1
27	144 130 014	Tube d'alimentation	Tube, connecting	Verbindungsrohr	Tubo de alimentación	3
29	144 130 192	Bouchon (par 5)	Plug (pack of 5)	Blindstopfen (5er Satz)	Tapón (x 5)	1
30	901 180 024	Câble de mise à la terre (Lg. 5 m)	Cable, ground (Length : 5m / 16.4 ft)	Erdungskabel (Länge: 5m)	Cable de puesta a tierra (5m de largo)	1

Ind	#	Désignation	Description	Bezeichnung	Denominación	Qté
		Pièces spécifiques au moteur 245-4	Specific parts to the air motor, model 245-4	Spezielle Teile für Luftmotor 245-4	Partes específicas al motor, tipo 245-4	
14a	909 420 305	Joint cylindre	Seal, cylinder	Dichtring, Zylinder	Junta de cilindro	2
15a	144 140 002	Cylindre air	Air cylinder	Luftzylinder	Cilindro aire	1
17a	144 140 003	Piston air	Air piston	Luftkolben	Pistón aire	1
18a	909 130 438	Joint torique (piston air)	Seal O-Ring (air piston)	O-Ring (Luftkolben)	Junta tórica (pistón de aire)	1
26a	909 210 404	Joint U	U seal	U-Dichtring	Junta U	1
28a	144 140 001	Bride moteur	Motor flange	Motorflansch	Brida motor	1

Ind	#	Désignation	Description	Bezeichnung	Denominación	Qté
		Pièces spécifiques au moteur 420-4	Specific parts to the air motor, model 420-4	Spezielle Teile für Luftmotor 420-4	Partes específicas al motor, tipo 420-4	
14b	909 420 304	Joint cylindre	Seal, cylinder	Dichtring, Zylinder	Junta de cilindro	2
15b	144 130 009	Cylindre air	Air cylinder	Luftzylinder	Cilindro aire	1
17b	144 130 002	Piston air	Air piston	Luftkolben	Pistón aire	1
18b	909 130 447	Joint torique (piston air)	Seal O-Ring (air piston)	O-Ring (Luftkolben)	Junta tórica (pistón de aire)	1
26b	909 210 403	Joint U	U seal	U-Dichtring	Junta U	1
28b	144 130 001	Bride moteur	Motor flange	Motorflansch	Brida motor	1

Ind	#	Désignation	Description	Bezeichnung	Denominación	Qté
*	144 140 190	Pochette de maintenance - Moteur 245-4 (rep. 7, 8, 12, 14a, 18a, 20, 21, 24, 26a)	Servicing kit - Motor 245-4 (Ind. 7, 8, 12, 14a, 18a, 20, 21, 24, 26a)	Servicekit - Luftmotor 245-4 (Inhalt: Pos. 7, 8, 12, 14a, 18a, 20, 21, 24, 26a)	Bolsa de reparación - Motor, tipo 245-4 (ind. 7, 8, 12, 14a, 18a, 20, 21, 24, 26a)	1
*	144 130 190	Pochette de maintenance - Moteur 420-4 (rep. 7, 8, 12, 14b, 18b, 20, 21, 24, 26b)	Servicing kit - Motor 420-4 (Ind. 7, 8, 12, 14b, 18b, 20, 21, 24, 26b)	Servicekit - Luftmotor 420-4 (Inhalt: Pos. 7, 8, 12, 14b, 18b, 20, 21, 24, 26b)	Bolsa de reparación - Motor, tipo 420-4 (ind. 7, 8, 12, 14b, 18b, 20, 21, 24, 26b)	1
*	144 130 191	Kit inverseur (rep. 7, 8, 12, 13)	Reversing kit (ind. 7, 8, 12, 13)	Umsteuerkit (Inhalt: Pos. 7, 8, 12, 13)	Kit inversor (ind. 7, 8, 12, 13)	1

* Pièces de maintenance préconisées.

* Preceding the index number denotes a suggested spare part.

* Bezeichnete Teile sind empfohlene Ersatzteile.

* Piezas de mantenimiento preventivas.

N C : Non commercialisé.

N S : Denotes parts are not serviceable.

N S : Bezeichnete Teile gibt es nicht einzeln, sondern nur komplett .

N S : no suministrado.

Doc. 573.474.050 Date/Datum/Fecha : 27/09/19 Annule/Cancel/ Ersetzt/Anula : 26/11/18	Modif. / Änderung : + # 144.135.237	Pièces de rechange Spare parts list Ersatzteilliste Piezas de repuesto
--	---	---

HYDRAULIQUE, modèle C50 (Entrée produit M 26x125)	FLUID SECTION, model C50 (Material inlet M 26x125)	#
HYDRAULIKTEIL, Modell C50 (Materialeingang M 26x1,25 AG)	HIDRÁULICA, tipo C50 (Entrada producto M 26x125)	144.135.250

HYDRAULIQUE, modèle C50 (Entrée produit F 1/2 G)	FLUID SECTION, model C50 (Material inlet F 1/2 G)	#
HYDRAULIKTEIL, Modell C50 (Materialeingang IG 1/2 G)	HIDRÁULICA, tipo C50 (Entrada producto H 1/2 G)	144.135.200

HYDRAULIQUE, modèle C50 MB-A (Entrée produit M 26x125)	FLUID SECTION, model C50 MB-A (Material inlet M 26x125)	#
HYDRAULIKTEIL, Modell C50 MB-A (Materialeingang M 26x1,25 AG)	HIDRÁULICA, tipo C50 MB-A (Entrada producto M 26x125)	144.135.350

HYDRAULIQUE, modèle C50 MB-A (Entrée produit F 1/2 G)	FLUID SECTION, model C50 MB-A (Material inlet F 1/2 G)	#
HYDRAULIKTEIL, Modell C50 MB-A (Materialeingang IG 1/2 G)	HIDRÁULICA, tipo C50 MB-A (Entrada producto H 1/2 G)	144.135.300

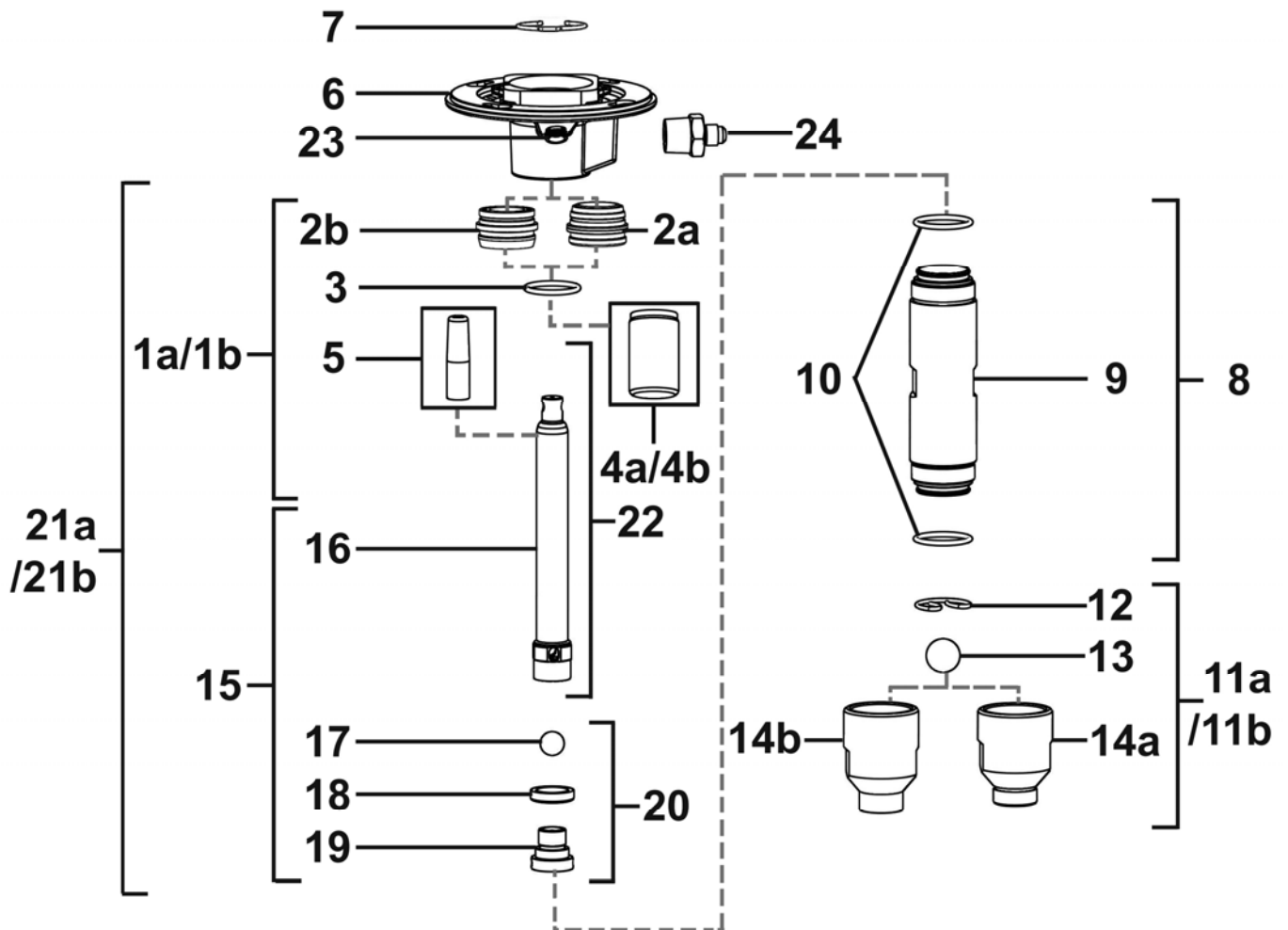

Pièces communes - Common parts - Gleiche Teile - Partes comunes

Ind	#	Désignation	Description	Bezeichnung	Denominación	Qté
6	NC / NS	Bride	Flange	Flansch	Brida	1
*8	144 135 292	Cylindre équipé (ind. 9, 10 x2)	Cylinder kit (ind. 9, 10 x2)	Materialzylinder komplett (Pos. 9, 10 St2)	Cilindro equipado (ind. 9, 10 x2)	1
9	144 135 202	▪ Cylindre	▪ Cylinder	▪ Materialzylinder	▪ Cilindro	1
10	150 040 343	▪ Joint torique PTFE (x 10)	▪ O Ring PTFE (x 10)	▪ O-Ring PTFE (Satz à 10 St.)	▪ Junta tórica PTFE (bolsa de 10)	2
*15	144 135 293	Kit piston (ind. 5, 16, 17, 18, 19)	Piston assembly (ind. 5, 16, 17, 18, 19)	Kolben komplett (Pos. 5, 16, 17, 18, 19)	Conjunto pistón (ind. 5, 16, 17, 18, 19)	1
*5	144 135 299	▪ Flamme : outillage pour montage garniture	▪ Piston rod starter tool	▪ Werkzeug für die Montage des Kolbens	▪ Herramienta para montar guarnición	1
*16	-	▪ Piston	▪ Piston	▪ Kolben	▪ Pistón	1
17	87 014	▪ Bille Ø 14, inox 420 C	▪ Ball, model Ø 14, (420 C stainless steel)	▪ Kugel Ø 14 Edelstahl 420 C	▪ Bola, tipo Ø 14 de inox 420 C	1
18	909 150 214	▪ Joint GT	▪ GT seal	▪ GT-Dichtung	▪ Junta GT	1
19	144 135 210	▪ Siège carbure	▪ Carbide seat	▪ Hartmetall-Sitz	▪ Asiento de carburo	1
*20	144 135 290	Kit clapet de refoulement (ind. 17, 18, 19)	Exhaust valve kit (ind. 17, 18, 19)	Kit Druckventil (Pos. 17, 18, 19)	Kit válvula de expulsión (ind. 17, 18, 19)	1
*22	144 135 209	Kit piston et flamme (ind. 5, 16)	Piston assembly and starter tool (ind. 5, 16)	Kolben mit Werkzeugsatz (Pos. 5, 16)	Kit pistón y herramienta (ind. 5, 16)	1
23	144 130 193	Bouchon de vidange (x 5)	Drain plug (x 5)	Entleerungsstopfen (5 St)	Tapón de vaciado (x 5)	1
24	050 102 616	Raccord inox M 1/2 NPT - M 1/2 JIC	Adaptor, stainless steel, double male, 1/2 NPT - 5 JIC (1/2 JIC)	Doppelnippel Edelstahl AG 1/2 NPT - AG1/2 JIC	Racor de inox M 1/2 NPT - M 1/2 JIC	1

Pièces spécifiques - Specific parts - Spezifische Teile - Partes específicas

Entrée produit M 26x125 / Material inlet M 26x125 / Materialeingang M 26x1,25 AG / Entrada producto M 26x125

Ind	#	Désignation	Description	Bezeichnung	Denominación	Qté
*11a	144 135 295	Clapet d'aspiration assemblé M 26x125 (ind. 12, 13, 14a)	Suction valve assembly M 26x125 (ind. 12, 13, 14a)	Ansaugventil komplett M 26 x 1,25 AG (Pos. 12, 13, 14a)	Válvula aspiración completa M 26x125 (ind. 12, 13, 14a)	1
12	144 135 208	▪ Jonc d'arrêt (x 4)	▪ Stop ring (x 4)	▪ Sicherungsring (x 4)	▪ Anillo de retención bola (x 4)	1
13	907 414 291	▪ Bille Ø 20 inox 440 C	▪ Ball Ø 20 (440 C stainless steel)	▪ Kugel, Edelstahl Ø 20 440 C	▪ Bola Ø 20 inox 440 C	1
14a	144 135 220	▪ Pied de pompe M 26x125	▪ Pump foot M 26x125	▪ Ansaugventil M 26 x 1,25 AG	▪ Pie de bomba M 26x125	1

Entrée produit F 1/2 G / Material inlet F 1/2 G / Materialeingang IG 1/2 G / Entrada producto H 1/2 G

Ind	#	Désignation	Description	Bezeichnung	Denominación	Qté
*11b	144 135 294	Clapet d'aspiration assemblé F 1/2 G (ind. 12, 13, 14b)	Suction valve assembly F 1/2 G (ind. 12, 13, 14b)	Ansaugventil komplett IG 1/2 G (Pos. 12, 13, 14b)	Válvula aspiración completa H 1/2 G (ind. 12, 13, 14b)	1
12	144 135 208	▪ Jonc d'arrêt (x 4)	▪ Stop ring (x 4)	▪ Sicherungsring (x 4)	▪ Anillo de retención bola (x 4)	1
13	907 414 291	▪ Bille Ø 20 inox 440 C	▪ Ball Ø 20 (440 C stainless steel)	▪ Kugel, Edelstahl Ø 20 440 C	▪ Bola Ø 20 inox 440 C	1
14b	144 135 215	▪ Pied de pompe F 1/2 G	▪ Pump foot F 1/2 G	▪ Ansaugventil IG 1/2 G	▪ Pie de bomba H 1/2 G	1

Cartouche MB-A / MB-A Cartridge / MB-A Packung / Cartucho MB-A

Ind	#	Désignation	Description	Bezeichnung	Denominación	Qté
*1a	144 135 365	Cartouche MB-A équipée	MB-A Cartridge kit	MB-A Packung komplett	Cartucho MB-A equipado	1
2a	NC / NS	▪ Cartouche MB-A	▪ MB-A Cartridge	▪ MB-A Packung	▪ Cartucho MB-A	1
3	150 040 342	▪ Joint de cartouche (x 5)	▪ Seal (pack of 5)	▪ Dichtring (5 St.)	▪ Junta (bolsa de 5)	1
*4a	-	▪ Poussoir montage cartouche	▪ Cartridge installation tool	▪ Werkzeug zur Montage der Packung	▪ Herramienta para montaje cartucho	1
*5	144 135 299	▪ Flamme : outillage pour montage garniture	▪ Piston rod starter tool	▪ Werkzeug für die Montage des Kolbens	▪ Herramienta para montar guarnición	1
*21a	144 135 389	Kit cartouche MB-A et piston (ind. 1a, 15)	MB-A cartridge and piston kit (ind. 1a, 15)	MB-A Packung und kolben komplett (Pos. 1a, 15)	Kit cartucho MB-A y pistón (ind. 1a, 15)	1

Cartouche GT / GT Cartridge / GT Packung / Cartucho GT

Ind	#	Désignation	Description	Bezeichnung	Denominación	Qté
*1b	144 135 205	Cartouche GT équipée	Cartridge kit	Packung komplett	Cartucho GT equipado	1
2b	NC / NS	▪ Cartouche inox	▪ Cartridge (stainless steel)	▪ Packung Edelstahl	▪ Cartucho de inox	1
3	150 040 342	▪ Joint de cartouche (x 5)	▪ Seal (pack of 5)	▪ Dichtring (5 St.)	▪ Junta (bolsa de 5)	1
*4b	144 135 298	▪ Poussoir montage cartouche	▪ Cartridge installation tool	▪ Werkzeug zur Montage der Packung	▪ Herramienta para montaje cartucho	1
*5	144 135 299	▪ Flamme : outillage pour montage garniture	▪ Piston rod starter tool	▪ Werkzeug für die Montage des Kolbens	▪ Herramienta para montar guarnición	1
*21b	144 135 291	Kit cartouche GT et piston (ind. 1b, 15)	GT cartridge and piston kit (ind. 1b, 15)	GT Packung und kolben komplett (Pos. 1b, 15)	Kit cartucho GT y pistón (ind. 1b, 15)	1

POCHETTES - KITS - SÄTZE - BOLSAS

Ind	#	Désignation	Description	Bezeichnung	Denominación	Qté
*	144 135 237	Pochette de maintenance (ind. 10(x2), 13, 17, 18)	Servicing kit (ind. 10(x2), 13, 17, 18)	Servicekit (beinhaltet Pos. 10(x2), 13, 17, 18)	Bolsa de mantenimiento (ind. 10(x2), 13, 17, 18)	1

ACCESSOIRES - ACCESSORIES - ZUBEHÖR - ACCESORIOS

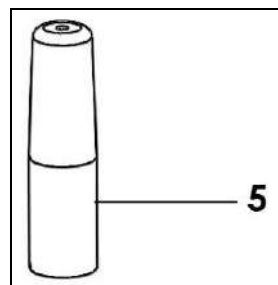
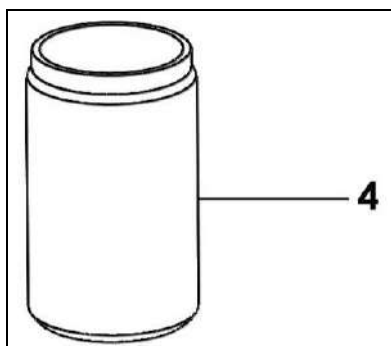

Ind	#	Désignation	Description	Bezeichnung	Denominación	Qté
*-	144 135 297	Kit outils (ind. 4b, 5)	Tool kit (ind. 4a, 5)	Werkzeugsatz (Pos. 4a, 5)	Kit herramienta (ind. 4a, 5)	1

* Pièces de maintenance préconisées.

* Preceding the index number denotes a suggested spare part.

* Bezeichnete Teile sind empfohlene Ersatzteile.

* Piezas de mantenimiento preventivas.

N C : Non commercialisé.









N S : Denotes parts are not serviceable.

N S : Bezeichnete Teile gibt es nicht einzeln, sondern nur komplett.

N S : no suministrado.

<p>Doc. 573.436.050 Date/Datum/Fecha : 07/12/18 Annule/Cancel/ Ersetzt/Anula : 13/12/17</p>	<p>Modif. / Änderung : EOS supprimé / canceled / annulliert / suprimido # 151 140 060 → NC / NS + # 151 140 080 + Mise à jour / Update / Aktualisierung / Actualización</p>	<p>Pièces de rechange Spare parts list Ersatzteilliste Piezas de repuesto</p>
---	--	--

EQUIPEMENT D'AIR	AIR SUPPLY
LUFTAUSRÜSTUNG	EQUIPO DE AIRE

		<p># NC / NS</p>
		<p># NC / NS</p>
		<p># 151.140.070</p>
		<p># 151.140.080</p>

EQUIPEMENT D'AIR POUR POMPE AIRMIX® / AIRSPRAY	AIR SUPPLY FOR AIRMIX® / AIRSPRAY PUMP	# NC / NS
LUFTAUSRÜSTUNG FÜR AIRMIX® / AIRSPRAY PUMPE	EQUIPO DE AIRE PARA BOMBA AIRMIX® / AIRSPRAY	# 151.140.070

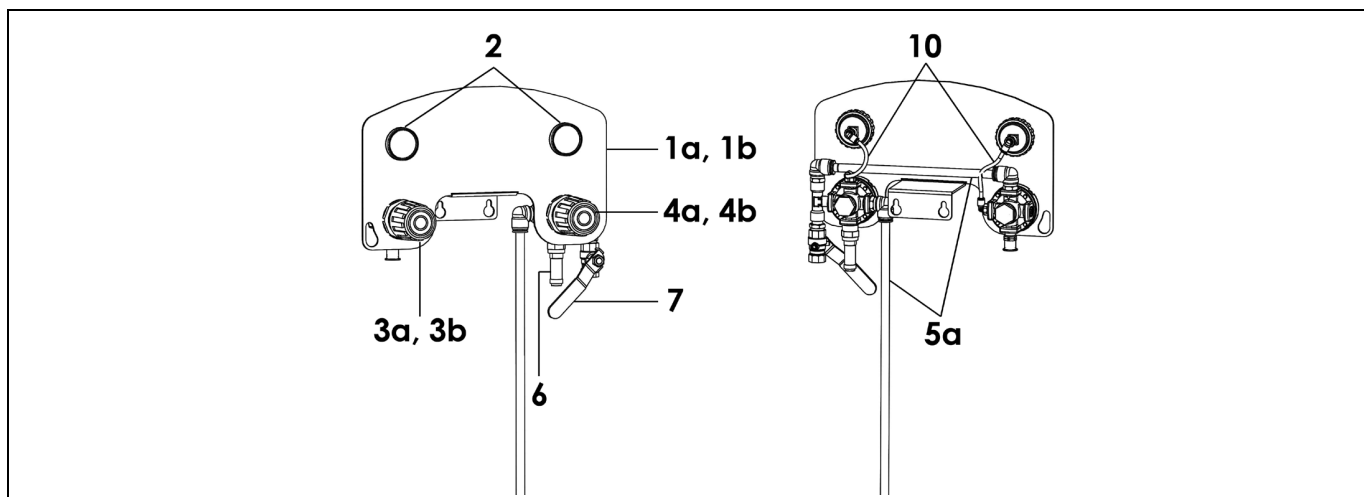

EQUIPEMENT D'AIR POUR POMPE AIRLESS	AIR SUPPLY FOR AIRLESS PUMP	# NC / NS
LUFTAUSRÜSTUNG FÜR AIRLESS PUMPE	EQUIPO DE AIRE PARA BOMBA AIRLESS	# 151.140.080

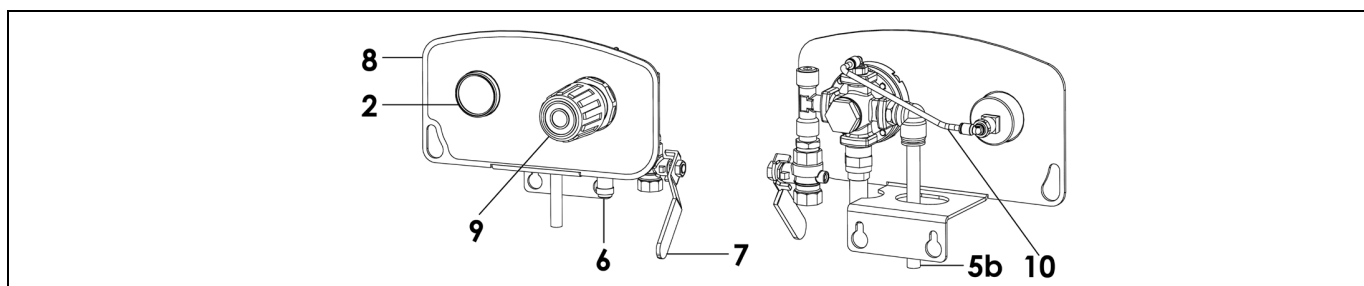

Pièces communes - Common parts - Gleiche Teile - Partes comunes

Ind	#	Désignation	Description	Bezeichnung	Denominación	Qté
2	910 011 205	Manomètre 0 - 6 bar	Gauge, model 0 - 6 bar / 0 - 87 psi	Manometer, 0-6 bar	Manómetro, tipo 0-6 bar	2
6	903 080 401	Soupage de décharge 6,5 bar	Discharge valve 6,5 bar / 94.27 psi	Sicherheitsventil 6,5 bar	Válvula de descarga 6,5 bar	1
7	903 090 209	Robinet F 3/8	Valve, model F 3/8	Absperrhahn, F 3/8	Grifo, tipo H 3/8	1
10	76 764	Tuyau 2,5 x 4 (lg. 25 m)	Hose, model 2,5 x 4 (length : 25 m / 82 ft)	Schlauch 2,5 x 4 (Länge : 25 m)	Tubería, tipo 2,5 x 4 (25 m de largo)	1

Pièces spécifiques - Specific parts - Spezifische Teile - Partes específicas

Pour / for / für / para Mod. AIRMIX® # NC / NS

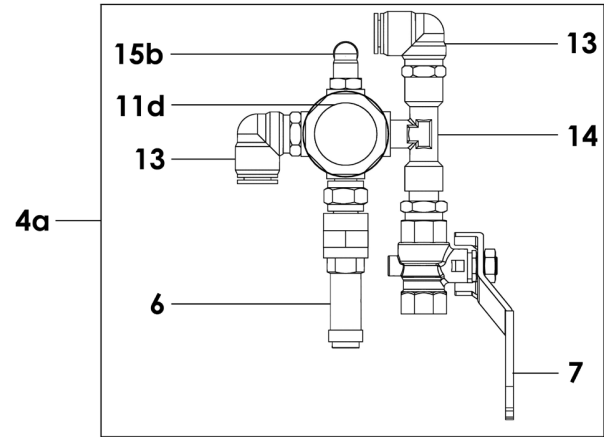
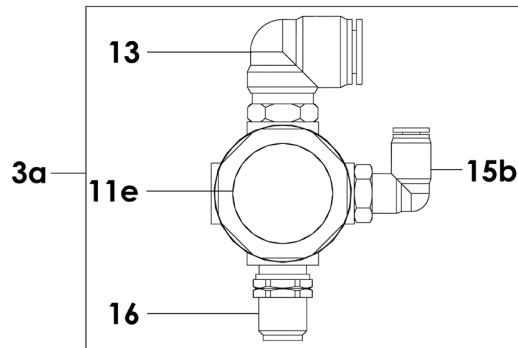

Ind	#	Désignation	Description	Bezeichnung	Denominación	Qté
1a	151 140 055	Support équipement d'air	Bracket, air supply	Lufteinheithalterung	Soporte del equipo de aire	1
3a	151 140 051	Détendeur d'air 1/4 (pistolet)	Air regulator, model 1/4 (gun)	Druckminderer, 1/4 (Pistole)	Manorreductor de aire, tipo 1/4 (pistola)	1
11e	903 130 802	▪ Détendeur d'air 1/4	▪ Air regulator, model 1/4	▪ Druckminderer, 1/4	▪ Manorreductor de aire, tipo 1/4	1
13	905 230 002	▪ Coude 1/4" G	▪ Elbow, model 1/4" G	▪ Winkelnippel AG 1/4" G	▪ Codo, tipo M 1/4" G	1
15b	905 230 003	▪ Coude 1/8" G	▪ Elbow, model 1/8" G	▪ Winkelnippel AG 1/8" G	▪ Codo, tipo M 1/8" G	1
16	050 102 624	▪ Raccord M 1/4 - M 1/4 NPS	▪ Adaptor, double male, 1/4 - 1/4 JIC NPS	▪ Doppelnippel AG 1/4 - AG 1/4 NPS	▪ Racor M 1/4 - M 1/4 NPS	1
4a	151 140 052	Détendeur d'air 1/4 (pompe)	Air regulator, model 1/4 (pump)	Druckminderer, 1/4 (Pumpe)	Manorreductor de aire, tipo 1/4 (bomba)	1
11d	903 130 801	▪ Détendeur d'air 1/4	▪ Air regulator, model 1/4	▪ Druckminderer, 1/4	▪ Manorreductor de aire, tipo 1/4	1
13	905 230 002	▪ Coude 1/4" G	▪ Elbow, model 1/4" G	▪ Winkelnippel AG 1/4" G	▪ Codo, tipo M 1/4" G	2
14	552 441	▪ Te FMF 1/4"	▪ Tee FMF 1/4"	▪ T-Stück AG-IG-AG 1/4"	▪ T MHM 1/4"	1
15b	905 230 003	▪ Coude 1/8" G	▪ Elbow, model 1/8" G	▪ Winkelnippel AG 1/8" G	▪ Codo, tipo M 1/8" G	1
5a	050 372 125	Tuyau 8 x 10 (lg. 25 m)	Hose, model 8 x 10 (length : 25 m / 82 ft)	Schlauch 8 x 10 (Länge : 25 m)	Tubería, tipo 8 x 10 (25 m de largo)	1

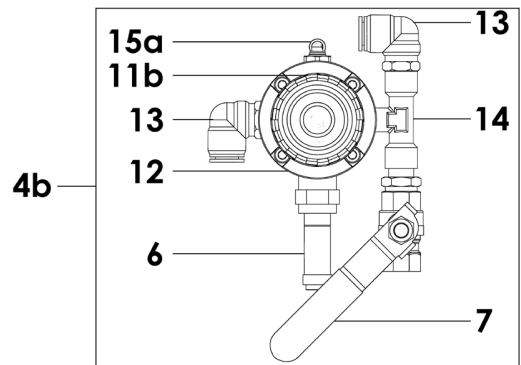
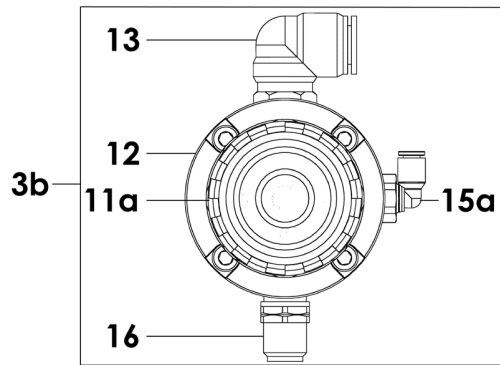

Ind	#	Désignation	Description	Bezeichnung	Denominación	Qté
1b	151 140 071	Support équipement d'air	Bracket, air supply	Lufteinheithalterung	Soporte del equipo de aire	1
3b	151 140 072	Détendeur d'air 1/4 (pistolet)	Air regulator, model 1/4 (gun)	Druckminderer, 1/4 (Pistole)	Manorreductor de aire, tipo 1/4 (pistola)	1
11a	116 380 700	▪ Détendeur d'air 1/4 noir (voir Doc. 573.288.040)	▪ Air regulator, model 1/4 black (refer to Doc. 573.288.040)	▪ Druckminderer, 1/4 Schwarz (Siehe Dok. 573.288.040)	▪ Manorreductor de aire, tipo 1/4 negro (consultar Doc. 573.288.040)	1
12	016 180 001	▪ Corps	▪ Body	▪ Körper	▪ Cuerpo	1
13	905 230 002	▪ Coude 1/4" G	▪ Elbow, model 1/4" G	▪ Winkelnippel AG 1/4" G	▪ Codo, tipo M 1/4" G	1
15a	905 120 927	▪ Coude 1/4" G	▪ Elbow, model 1/4" G	▪ Winkelnippel AG 1/4" G	▪ Codo, tipo M 1/4" G	1
16	050 102 624	▪ Raccord M 1/4 - M 1/4 NPS	▪ Adaptor, double male, 1/4 - 1/4 JIC NPS	▪ Doppelnippel AG 1/4 - AG 1/4 NPS	▪ Racor M 1/4 - M 1/4 NPS	1
4b	151 140 075	Détendeur d'air 1/4 (pompe)	Air regulator, model 1/4 (pump)	Druckminderer, 1/4 (Pumpe)	Manorreductor de aire, tipo 1/4 (bomba)	1
11b	116 370 700	▪ Détendeur d'air 1/4 phosphore (voir Doc. 573.288.040)	▪ Air regulator, model 1/4 (refer to Doc. 573.288.040)	▪ Druckminderer, 1/4 (Siehe Dok. 573.288.040)	▪ Manorreductor de aire, tipo 1/4 (consultar Doc. 573.288.040)	1
12	016 180 001	▪ Corps	▪ Body	▪ Körper	▪ Cuerpo	1
13	905 230 002	▪ Coude 1/4" G	▪ Elbow, model 1/4" G	▪ Winkelnippel AG 1/4" G	▪ Codo, tipo M 1/4" G	2
14	552 441	▪ Te FMF 1/4"	▪ Tee FMF 1/4"	▪ T-Stück AG-IG-AG 1/4"	▪ T MHM 1/4"	1
15a	905 120 927	▪ Coude 1/4" G	▪ Elbow, model 1/4" G	▪ Winkelnippel AG 1/4" G	▪ Codo, tipo M 1/4" G	1
5a	050 372 125	Tuyau 8 x 10 (lg. 25 m)	Hose, model 8 x 10 (length : 25 m / 82 ft)	Schlauch 8 x 10 (Länge : 25 m)	Tubería, tipo 8 x 10 (25 m de largo)	1

Pour / for / für / para Mod. AIRLESS # NC / NS

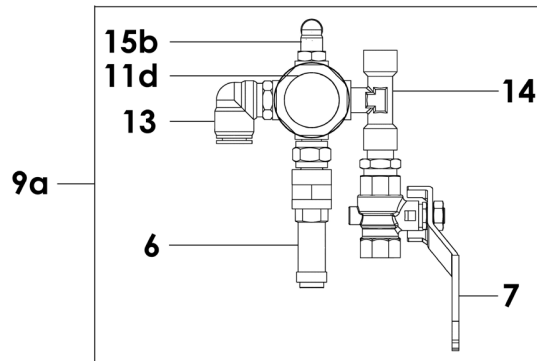

Ind	#	Désignation	Description	Bezeichnung	Denominación	Qté
5a	050 372 125	Tuyau 8 x 10 (lg. 25 m)	Hose, model 8 x 10 (length : 25 m / 82 ft)	Schlauch 8 x 10 (Länge : 25 m)	Tubería, tipo 8 x 10 (25 m de largo)	1
8a	151 140 061	Support équipement d'air	Bracket, air supply	Lufteinheithalterung	Soporte del equipo de aire	1
9a	151 140 057	Détendeur d'air 1/4 (pompe)	Air regulator, model 1/4 (pump)	Druckminderer, 1/4 (Pumpe)	Manorreductor de aire, tipo 1/4 (bomba)	1
11d	903 130 801	▪ Détendeur d'air 1/4	▪ Air regulator, model 1/4	▪ Druckminderer, 1/4	▪ Manorreductor de aire, tipo 1/4	1
13	905 230 002	▪ Coude 1/4" G	▪ Elbow, model 1/4" G	▪ Winkelnippel AG 1/4" G	▪ Codo, tipo M 1/4" G	1
14	552 441	▪ Te FMF 1/4"	▪ Tee FMF 1/4"	▪ T-Stück AG-IG-AG 1/4"	▪ T MHM 1/4"	1
15b	905 230 003	▪ Coude 1/8" G	▪ Elbow, model 1/8" G	▪ Winkelnippel AG 1/8" G	▪ Codo, tipo M 1/8" G	1

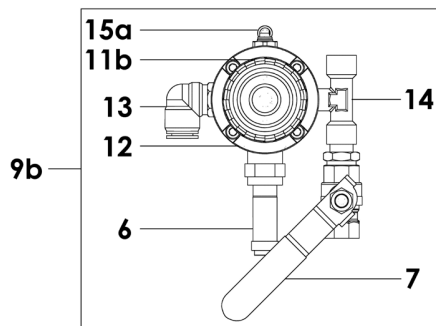

Ind	#	Désignation	Description	Bezeichnung	Denominación	Qté
5b	539 090 103	Tuyau 8 x 10 (lg. 100 m)	Hose, model 8 x 10 (length : 100 m / 328 ft)	Schlauch 8 x 10 (Länge : 100 m)	Tubería, tipo 8 x 10 (100 m de largo)	1
8b	151 140 081	Support équipement d'air	Bracket, air supply	Lufteinheithalterung	Soporte del equipo de aire	1
9b	151 140 074	Détendeur d'air 1/4 (pompe)	Air regulator, model 1/4 (pump)	Druckminderer, 1/4 (Pumpe)	Manorreductor de aire, tipo 1/4 (bomba)	1
11b	116 370 700	▪ Détendeur d'air 1/4 phosphore (voir Doc. 573.288.040)	▪ Air regulator, model 1/4 (refer to Doc. 573.288.040)	▪ Druckminderer, ¼ (Siehe Dok. 573.288.040)	▪ Manorreductor de aire, tipo 1/4 (consultar Doc. 573.288.040)	1
12	016 180 001	▪ Corps	▪ Body	▪ Körper	▪ Cuerpo	1
13	905 230 002	▪ Coude 1/4" G	▪ Elbow, model 1/4" G	▪ Winkelnippel AG 1/4" G	▪ Codo, tipo M 1/4" G	1
14	552 441	▪ Te FMF 1/4"	▪ Tee FMF 1/4"	▪ T-Stück AG-IG-AG 1/4"	▪ T MHM 1/4"	1
15a	905 120 927	▪ Coude 1/4" G	▪ Elbow, model 1/4" G	▪ Winkelnippel AG 1/4" G	▪ Codo, tipo M 1/4" G	1

* Pièces de maintenance préconisées.

* Preceding the index number denotes a suggested spare part.

* Bezeichnete Teile sind empfohlene Ersatzteile.

* Piezas de mantenimiento preventivas.

N C : Non commercialisé.

N S : Denotes parts are not serviceable.

N S : Bezeichnete Teile gibt es nicht einzeln, sondern nur
komplett .

N S : no suministrado.

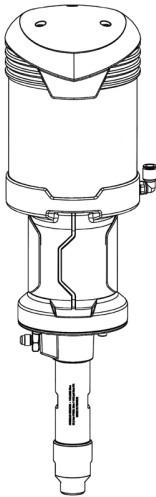

PUMPS AIRMIX® / AIRLESS XXC25 / XXC50

PREVENTIVE MAINTENANCE

TRANSLATION FROM THE ORIGINAL MANUAL

IMPORTANT : Before assembly and start-up, please read and clearly understand all the documents relating to this equipment (professional use only).

THE PICTURES AND DRAWINGS ARE NON CONTRACTUAL. WE RESERVE THE RIGHT TO MAKE CHANGES WITHOUT PRIOR NOTICE.

SAMES KREMLIN SAS
13, chemin de Malacher
38 240 - MEYLAN - France
☎ : 33 (0)4 76 41 60 60

www.sames-kremlin.com

Guards (air motor cover, coupling shields, housings ...) have been designed for safe use of the equipment.

The manufacturer will not be held responsible for bodily injury or failure and / or damage to property due to removal or partial removal of the guards

OPERATION TO CARRY OUT	FREQUENCY					
	D	W	M	Q	H	Y
GENERAL						
Check earthings	X					
Check leakage from the fittings	X					
Check hoses	X					
Operate the valves			X			
PUMP						
Clean the pistons of the pumps (do not let the material dry)		X				
Check piston rod tightness		X				
Check there is no leak at the upper cartridge		X				
Check the cleanliness and the level of the T lubricant		X				
Check the cleanliness of the strainer		X				
Drain and replace the T lubricant			X			
Caution : flush the pump for a long duration shutdown of the installation (more than two weeks)						
MOTOR						
Check the tightness of the piston rod					X	
Check if the control system is clean			X			
Check if the muffler(s) is clogged						X
Check that there is no air leakage						X
Check that air hoses are not damaged						X
Check that the connections between fittings and hoses are correct						X
Check the correct condition of the supply hoses (rubber, setting,...), regulators and gauges						X
Check the tightening of the components						X
Check the fixing of the cover						X
Check the correct operating of the safety valve(s)						X
D : daily W : weekly M : monthly Q : quarterly H : half-yearly Y : yearly						

OPERATION TO CARRY OUT	FREQUENCY					
	D	W	M	Q	H	Y
FLUID SECTION						
Check the tightness of the cup				X		
Check if there is lubricant in the cupel (keep the level halfway up)		X				
Disassemble the fluid section, clean the parts with the appropriate cleaning solvent, change the seals and the parts if necessary						X
Change the lubricant if the coloration is too important and change the seals of the upper flange if the problem persists			X			
Clean regularly the cup with lubricant after having drained the lubricant		X				
D : daily		M : monthly		H : half-yearly		
W : weekly		Q : quarterly		Y : yearly		

Note : Frequencies are given as a clue. They must be adapted by the maintenance service of the user for every installation according to the product, the working cadence and the working pressure.

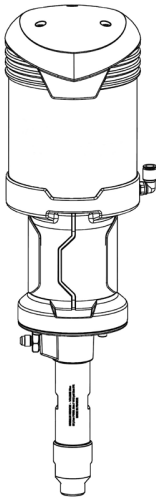

PUMPS AIRMIX® / AIRLESS XXC25 / XXC50

TROUBLESHOOTING GUIDE

TRANSLATION FROM THE ORIGINAL MANUAL

IMPORTANT : Before assembly and start-up, please read and clearly understand all the documents relating to the equipment (professional use only).

THE PICTURES AND DRAWINGS ARE NOT CONTRACTUAL. WE RESERVE THE RIGHT TO MAKE CHANGES WITHOUT PRIOR NOTICE.

SAMES KREMLIN SAS
13, chemin de Malacher
38 240 - MEYLAN - France
☎ : 33 (0)4 76 41 60 60

www.sames-kremlin.com

Guards (air motor cover, coupling shields, housings ...) have been designed for safe use of the equipment.
The manufacturer will not be held responsible for bodily injury or failure and / or damage to property due to removal or partial removal of the guards



CAUTION :

Before any intervention on the equipment, shut off the air supply and follow the general safety instructions. Open the drain or the gun to depressurize the gun. The ram must be in the low position.

CAUSE	SOLUTION
The pump does not start	Check the pump air supply. Refer to spray gun manual.
Priming trouble : → Air is always coming out from the spray gun → When priming, air (or material) does not come out from the spray gun	Be sure that the spray gun is fully opened and air evacuated through this one. Check the cleanliness of the strainer. Air intake at the fittings or at the suction rod. Check the upper spring. Change the valve under the cover. Check the pump valves. If a valve is stucked by dry paint, it can be unsticked without disassembling it. Blow air pressure directly by suction fitting.
The pump does not stop at once when shutting off the spray gun : → The pump stops only on down stroke → The pump stops only on up stroke	Check exhaust valve or piston seal. Check / change the upper spring. Change the valve under the cover. Check suction valve or upper cartridge. Blow air pressure in the suction valve. Check the valve and the lower spring.
The pump locks with an air leakage to the motor	Check the motor valve under the cover, the seal O-ring and the seal holder
On cup lub pump, the product overflow from the tank and leaves by the leakage outlet	Check the upper packing (GT cartridge, MB-A cartridge), change cartridge if it is necessary. Check / change the upper cartridge and the piston rod.
Spraying trouble	Refer to spray gun manual.



**PUMPS
AIRMIX® / AIRLESS
XX-C25 / XX-C50**

OPERATING PRINCIPLE AND START-UP

TRANSLATION FROM THE ORIGINAL MANUAL

IMPORTANT : Before assembly and start-up, please read and clearly understand all the documents relating to the equipment (professional use only).

THE PICTURES AND DRAWINGS ARE NOT CONTRACTUAL. WE RESERVE THE RIGHT TO MAKE CHANGES WITHOUT PRIOR NOTICE.

SAMES KREMLIN SAS
13, chemin de Malacher
38 240 - MEYLAN - France
☎ : 33 (0)4 76 41 60 60

www.sames-kremlin.com

1. OPERATING PRINCIPLE

The pump consists of :

- an alternating air motor (B),
- an hydraulic section (C) mechanically coupled to the air motor (B).

The air motor is supplied with compressed air by means of the regulator (D). The pressure is read on the gauge (E).

During its alternating movement, the air motor drives the piston of the hydraulic section (C), the fluid is drawn in (L) and forced under pressure in (N).

Due to its design, this pressure is always the one read on the gauge

Example : for a pump ratio 07/1 : $7 \times 6 \text{ bar} = 42 \text{ bar}$ / $7 \times 87 \text{ psi} = 609 \text{ psi}$

The spraying air pressure of the gun is adjusted by means of the regulator (knob) (F) and the pressure can be read on the gauge (G) (Only Airmix® model : see figure1).

- To adjust the fluid flow rate, turn the regulator (D).
- To adjust the spraying air, turn the regulator (F) (read on the gauge (G) (Only Airmix® model : see figure 1).

2. START UP

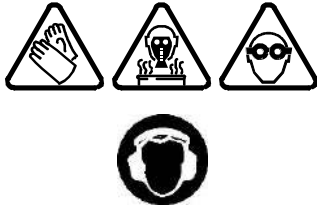

Protective clothing (gloves, protective masks, glasses, hearing protective earplug, protective clothing) should be worn to comply with the recommendations.

The working area must be correctly ventilated.

2-1 FILLING

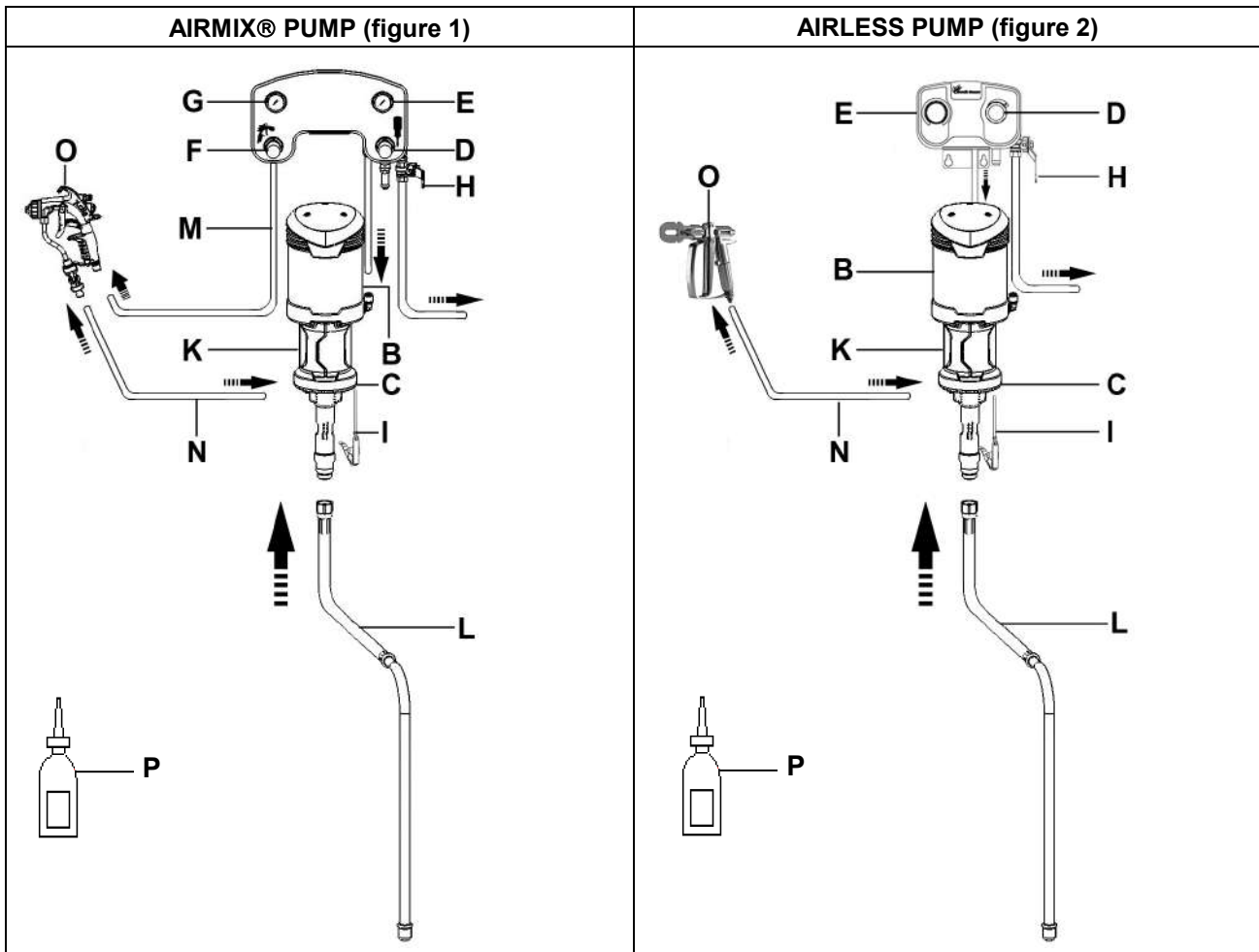

Captions :

<p>A pump (B + C)</p> <p>B Motor</p> <p>C Fluid section</p> <p>D 'MOTOR AIR' regulator</p> <p>E Gauge</p> <p>F 'GUN AIR' regulator</p> <p>G Gauge</p> <p>H Air inlet valve</p> <p>I Ground</p>	<p>K Protection carter</p> <p>L Suction rod</p> <p>M Air static (static conductor)</p> <p>N HP fluid section</p> <p>O AIRMIX® or AIRLESS gun</p> <p>P T lubricant (125 ml / 4.4 oz)</p>
--	---

(For specific installation, please contact your SAMES KREMLIN representative).

Guards (air motor cover, coupling shields, housings ...) have been designed for safe use of the equipment.

The manufacturer will not be held responsible for bodily injury or failure and / or damage to property due to removal or partial removal of the guards

Start up procedure :

- Ground the pump.
- **If the pump is a cup lub one, fill the wetting cup (S) with T lubricant (P) or with an appropriate cleaning solvent.**
- Unscrew the air regulators (D and F),
- Interconnect the equipment with the air pressure network (clean and dry air - P < 6 bar / 87 psi)
Install a water drop, if it is necessary.
- Connect all the hoses (M& N) as well as the gun (O).
- Remove the gun air cap by unscrewing the cap ring and nozzle (only in case of an Airmix® gun).

▪ **FLUSHING WITH SOLVENT**

- Immerse suction rod (L) into solvent-filled container.
- Open motor air pressure supply - valve (H).
- Point the spray gun, not supplied with air, towards the material container and press the trigger.
- Increase **gradually** the air regulator (D) so that the pump runs slowly (Proportionally to pressure ratio). When material flows out regularly, release the trigger.
- Drain all solvent from the pump.

▪ **PRIMING WITH MATERIAL**

- Immerse suction rod (L) into material container.
- Point the spray gun, not supplied with air, towards the material container and trigger the gun until the material flows out regularly.

▪ **WORK**

- Reinstall the ring, the aircap and the nozzle (only in case of an Airmix® gun) on the gun.
- Adjust air regulator (D) to get the appropriate material pressure and flow rate.
- **Gradually** open air regulator (F) to adjust spraying air to obtain the required spray pattern.

2-2 PUMP SUPPLIED IN GRAVITY

➡ **CAUTION: The pumps can be supplied in gravity but not in filling.**

Interconnect the pump fluid inlet with the gravity cup supply hose and start up the pump as previously indicated.

3. SHUTDOWN AT THE END OF THE WORK

▪ SHORT DURATION SHUTDOWN

- Decrease the material pressure of air regulator (D) until reading **0 bar / 0 psi** on gauge (E).
- Trigger the gun to depressurize the system.
- Unscrew the gun air regulator (F) or disconnect the gun air inlet.
- Remove the gun air cap and the nozzle (only in case of an Airmix® gun) from the spray gun and soak it into solvent.

▪ LONG DURATION SHUTDOWN

- Decrease the material pressure of air regulator (D) so that the pump runs slowly.
- Unscrew the gun air regulator (F) or disconnect the gun air inlet.
- Remove the gun air cap and the nozzle (only in case of an Airmix® gun) from the spray gun and soak it into solvent.
- Remove the suction rod from the material container and immerse it in a solvent-filled container. Take all the appropriate precautions in the presence of flammable solvents.
- Point the gun towards the container and trigger the gun. When the solvent flows out, point the gun towards the recovery container.
- When the solvent flows out clean, release the gun trigger.

Nota : If the pump is a cup lub one, release the spray gun trigger when the pump piston is in a low position. To prevent from damaging the seals when starting once again the pump, the piston must be immersed into solvent.

- Fully unscrew the air regulator (D) and shut off the compressed air valve (valve H).
- Trigger the spray gun to decompress the hoses. Therefore, the pump and the hose remain filled with solvent at the atmospheric pressure.

4. SAFETY DEVICE

**Guards (air motor cover, coupling shields, housings ...) have been designed for safe use of the equipment.
The manufacturer will not be held responsible for bodily injury or failure and / or damage to property due to removal or partial removal of the guards**

AIRMIX® pump : A relief-valve (setting : 6.5 bar / 94 psi) is fitted on the pump air motor - thus protecting this one from an overpressure which could damage it.

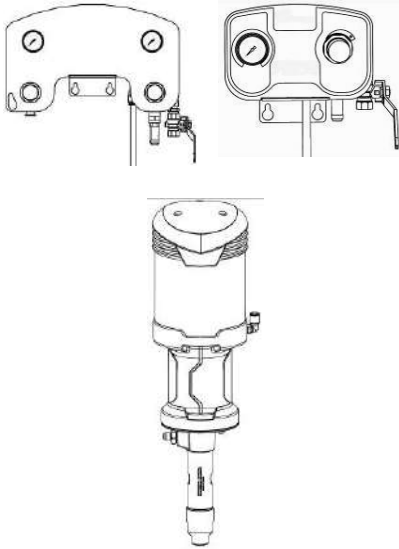

PUMPS

15C50

TECHNICAL FEATURES

TRANSLATION FROM THE ORIGINAL MANUAL

IMPORTANT : Before assembly and start-up, please read and clearly understand all the documents relating to this equipment (professional use only).

THE PICTURES AND DRAWINGS ARE NON CONTRACTUAL. WE RESERVE THE RIGHT TO MAKE CHANGES WITHOUT PRIOR NOTICE.

SAMES KREMLIN SAS
13, chemin de Malacher
38 240 - MEYLAN - France
☎ : 33 (0)4 76 41 60 60

www.sames-kremlin.com

1. DESCRIPTION

- Compact pneumatic pump
- Low maintenance and ease of use

Designed for :

- Supplying one or two guns, model AIRMIX® or AIRLESS depending upon the pump configuration
- For all kind of paints and varnishes

2. TECHNICAL FEATURES

▪ PUMP 15C50

Motor model.....	420-4
Pump body model.....	50 cc
Pressure ratio.....	15/1
Weight (bare wall mounted pump)...	8 kg

Wetted parts :

- Flange : Stainless steel
- Cylinder : Hard chrome stainless steel
- Piston : Hard chrome stainless steel
- Seat : Stainless steel / Carbide
- Pump foot : Stainless steel / Carbide

Pump sealing :

- Upper : Stainless steel / UHMW Polyethylene cartridge
- Lower : UHMW Polyethylene seal

Motor stroke	100 mm	4"
Air motor piston section	42 cm ²	6.5 sq.in
Fluid section	5,3 cm ²	0.82 sq. In
Fluid delivery per cycle	50 cm ³	1.69 oz
Number of cycle for 1 liter of product	20	20
Fluid delivery (30 cycles)	1,5 l	0.4 US gal
Maximum air inlet pressure	6 bar	87 psi
Maximum fluid discharge pressure	95 bar	1305 psi
Weighted sound pressure (LAeq)	76,6 dBa	76,6 dBa
Maximum operating temperature	60°C	140 °F

Fluid outlet pressure and air consumption depending upon the air supply pressure :

- 2 bar : 54l/min,
- 4 bar : 90l/min,
- 6 bar : 126l/min.

Nota : Data given for your information only.

Test conditions :

- Test duration : 30 s,
- Motor air pressure: 6 bar / 87 psi,
- Material used : water,
- Gun : Xcite™,
- Tip : 09.

▪ **FITTINGS**

- **Fittings - Fluid section, model C50 M 26 x 125**

		Bare pump	Pump assembly
Air	Inlet	F 3/8" BSP	F 3/8" BSP (valve)
	Outlet	-	M 1/4" NPS (spraying air)
Fluid	Inlet	M 26 x 125	Suction rod
	Outlet	F 3/8" NPS	M 1/2" JIC

- **Fittings - Fluid section, model C50 F 1/2 G**

		Bare pump	Pump assembly
Air	Inlet	F 3/8" BSP	F 3/8" BSP (valve)
	Outlet	-	M 1/4" NPS (spraying air)
Fluid	Inlet	F 1/2" G	Suction rod
	Outlet	F 3/8" NPS	M 1/2" JIC

▪ DIMENSIONS

- Pump

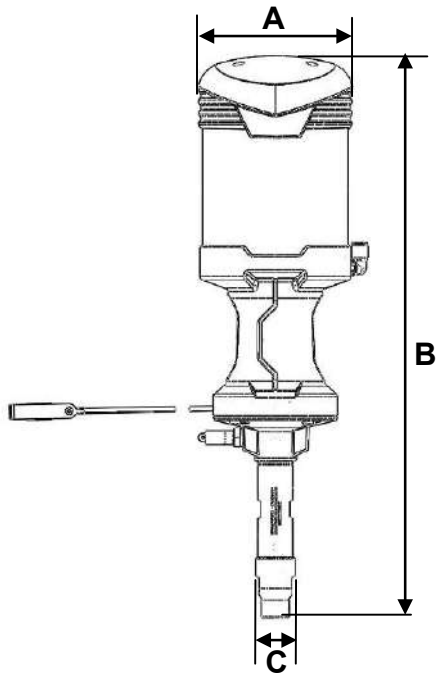

Ind.	mm	"	Ind.	mm	"
A	Ø 159	Ø 6.26	B	585	23
Ind.	mm	"			
C	Ø 45	Ø 1.77			

Pump bracket

Ind.	mm	"	Ind.	mm	"
D	25	0.98	E	146	5.74
Ind.	mm	"	Ind.	mm	"
F	62	2.44	G	50	1.96
Ind.	mm	"	Ind.	mm	"
H	Ø 6,5	Ø 0.25	I	10	0.4
Ind.	mm	"			
J	72	2.83			

• AIRMIX® air equipment

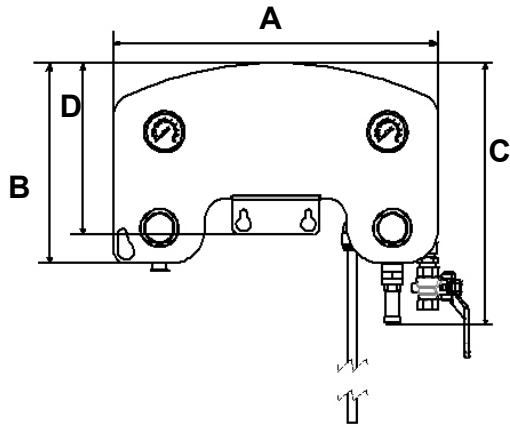

Ind.	mm	"	Ind.	mm	"
A	320	12.6	B	198	7.8
Ind.	mm	"	Ind.	mm	"
C	260	10.2	D	169	6.7

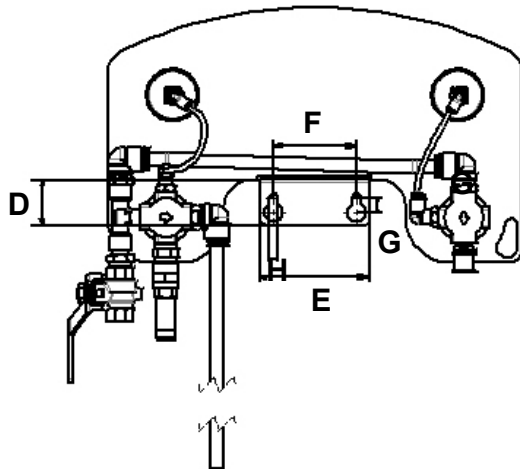

Ind.	mm	"	Ind.	mm	"
D	35	1.4	E	85	3.3
Ind.	mm	"	Ind.	mm	"
F	64	2.5	G	11	0.4
Ind.	mm	"			
H	Ø 6,5	Ø 0.25			

• AIRLESS air equipment
(without spraying air)

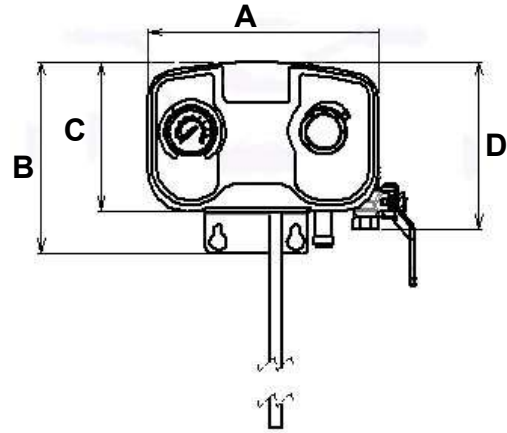

Ind.	mm	"	Ind.	mm	"
A	190	7.5	B	159	6.3
Ind.	mm	"	Ind.	mm	"
C	124	4.9	D	139	5.5

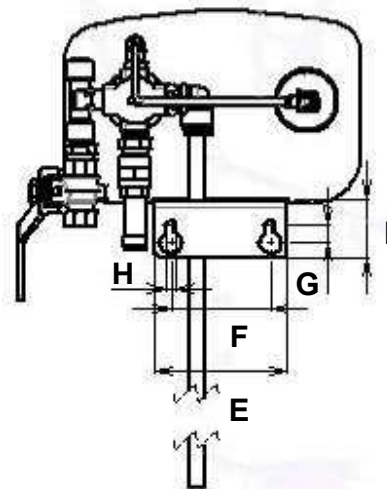

Ind.	mm	"	Ind.	mm	"
E	85	3.3	F	64	2.5
Ind.	mm	"	Ind.	mm	"
G	11	0.4	H	Ø 6,5	Ø 0.25
Ind.	mm	"			
I	38	1.5			

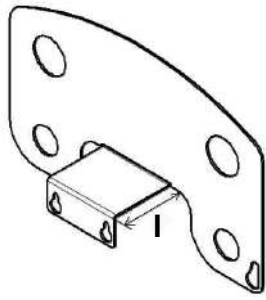

Ind.	mm	"
I	72	2.8

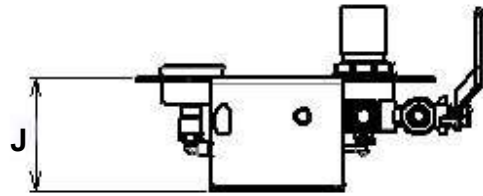





Ind.	mm	"
I	72	2.8



3. INSTALLATION

The pumps are designed to be installed in a spray booth.

DESCRIPTION OF THE LABEL MARKING

Marking according to the ATEX regulation
(Ex : version 15C50)

   II 2 G Ex h IIA TX Gb	
STAINS FRANCE	
Type de pompe / Pump Type :	15-C50
Rapport de pression / Pressure Ratio :	15 : 1
Débit par Cycle / Fluid Flow per Cycle :	50 cc / 1,7 oz
Pression Air Max / Max Air pressure :	6 bar / 87 psi
Pression Prod Max / Max Fluid pressure :	95 bar / 1305 psi
Numéro de série / Serial Number	2017361-1234567-06
	
Designed & Made in France	<i>Lire la notice avant utilisation</i> <i>Read instruction manual before use</i>

Sigle SAMES KREMLIN	Manufacturer brand
Made in France	Country of manufacture
CE  II 2 G	CE : European conformity  : For use in explosive area II : group II 2 : class 2 G : gas Surface equipment meant to an area where explosive atmospheres due to gas, vapours, mists are liable to appear from time to time in usual operating.
Ex h IIA TX	Ex : Marking of conformity with European standards h : Mode of protection for non electrical device IIA : Gas group TX : Temperature class - Maximum surface temperature : See table below*
Gb	Gb : Equipment protection level (Gas zone1)
Type de pompe / Pump type	Pump version
Rapport de pression / Pressure ratio	Pump pressure ratio
Débit par cycle / Fluid flow per cycle	Fluid section capacity
Pression air max. / Max. air pressure	Maximum pump motor air supply maximum
Pression prod max. / Max. fluid pressure	Maximum fluid pressure at the outlet of the pump
Numéro de série / Serial number	Number given by SAMES KREMLIN. The four first numbers indicate the manufacturing year.

* Temperature class

Cartridge	Temperature class	Maximum surface temperature
GT	T3	200°C / 392 °F
MB-A	T3	200°C / 392 °F

■ INSTALLATION DIAGRAM

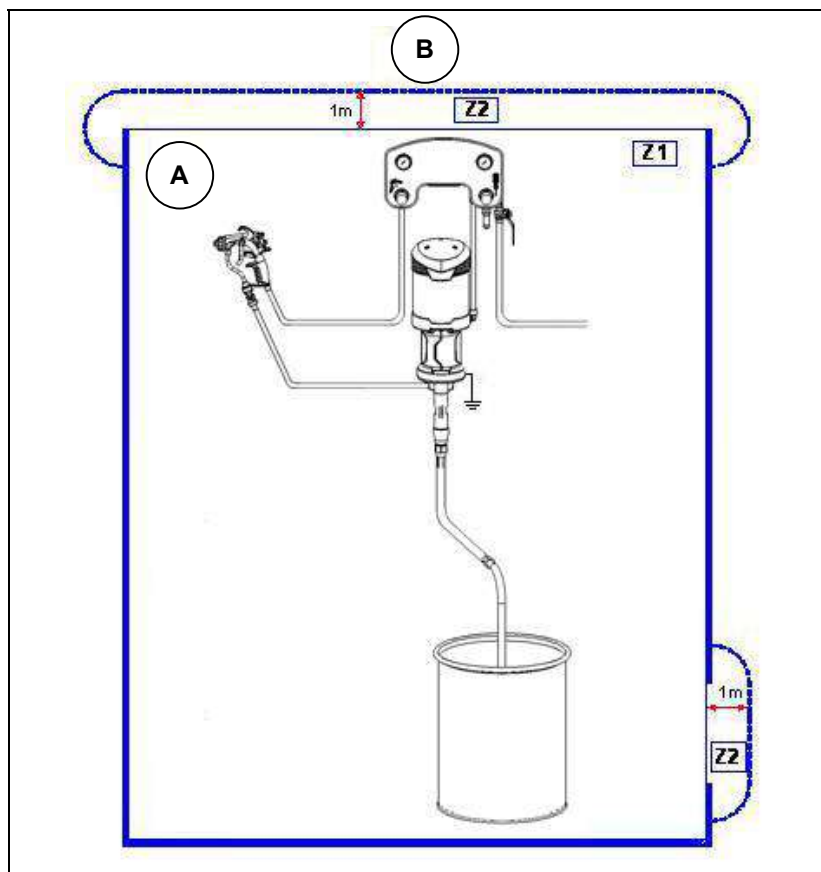

A	Explosive area Area 1 (Z1) or area 2 (Z2) : spray booth
----------	--

B	Non explosive area
----------	--------------------