



TurboDisk™ Applicator Assembly
Model: A11376



NOTE: This manual has been changed from revision **AA-07-02.2** to revision **AA-07-02-R3**. Reasons for this change are noted under “Manual Change Summary” inside the back cover of this manual.

CONTENTS

SAFETY:	5-9
Safety Precautions	5
Hazards / Safeguards	6
INTRODUCTION:	10-13
Features	10
General Description	10
Approvals	11
Specifications	11
Typical Speed Chart (RPM's No Load)	12
Typical Speed Chart - 10 Hole Orifice Plate (No Load)	12
INSTALLATION:	14-15
Equipment	14
Air Control	14
Mounting	14
Interlocks	14
Typical Layout of System	15
OPERATION:	16-19
Air Heater Requirements	16
Coating Materials	17
Fluid Flow Control	17
Fluid Valve Control	17
Fluid and Air Pressure Requirements	17
Turbine Speed	18
Electrostatic Voltage	19
Target Distance	19
MAINTENANCE:	20-30
General	20
Cleaning Procedures	20
Vibration Noise	22
Turbine Repair and Rebuild	22
Valves and Regulators	22
Preventive Maintenance	22
Disassembly Procedures	23
Troubleshooting Guide	25
Typical Schematics	26
PARTS IDENTIFICATION:	31-64
A11376 TurboDisk Assembly Model Identification	31
70988 Basic Systems Kit	34

(Continued On Next Page)

CONTENTS (Cont.)

PARTS IDENTIFICATION (Cont.):	31-64
TurboDisk Assemblies:	
No Valves 70990-05	36
3-Way Valves 70990-06	38
Trigger Valve Only 70990-07	40
Trigger and Dump Valve 70990-08	43
Trigger Valve Only with DR-1 Regulator 70990-09	46
Trigger and Dump Valve with DR-1 Regulator 70990-10	49
Dual DR-1 Regulator 70990-11	52
Drive Air Regulator 78170-00	55
Air Heater and Regulator 78781-00	56
Fairing 70158-00	57
Air Turbine 78175-XX	59
Turbine Cartridge 70879-XXX	61
Recommended Spare Parts	63
Tools and Accessories	64
MANUAL CHANGE SUMMARY:	65
Manual Changes	65

SAFETY

SAFETY PRECAUTIONS

Before operating, maintaining or servicing any electrostatic coating system, read and understand all of the technical and safety literature for your products. This manual contains information that is important for you to know and understand. This information relates to **USER SAFETY** and **PREVENTING EQUIPMENT PROBLEMS**. To help you recognize this information, we use the following symbols. Please pay particular attention to these sections.

WARNING

A **WARNING!** states information to alert you to a situation that might cause serious injury if instructions are not followed.

CAUTION

A **CAUTION!** states information that tells how to prevent damage to equipment or how to avoid a situation that might cause minor injury.

NOTE

A **NOTE** is information relevant to the procedure in progress.

While this manual lists standard specifications and service procedures, some minor deviations may be found between this literature and your equipment. Differences in local codes and plant requirements, material delivery requirements, etc., make such variations inevitable. Compare this manual with your system installation drawings and associated equipment manuals to reconcile such differences.

Careful study and continued use of this manual will provide a better understanding of the equipment and process, resulting in more efficient operation, longer trouble-free service and faster, easier troubleshooting. If you do not have the manuals and safety literature for your equipment, contact your local Carlisle Fluid Technologies representative or Carlisle Fluid Technologies technical support.

WARNING



- The user **MUST** read and be familiar with the Safety Section in this manual and the safety literature therein identified.
- This equipment is intended to be used by trained personnel **ONLY**.
- This manual **MUST** be read and thoroughly understood by **ALL** personnel who operate, clean or maintain this equipment! Special care should be taken to ensure that the **WARNINGS** and safety requirements for operating and servicing the equipment are followed. The user should be aware of and adhere to **ALL** local building and fire codes and ordinances as well as **NFPA 33 AND EN 16985 SAFETY STANDARDS, LATEST EDITION**, or applicable country safety standards, prior to installing, operating, and/or servicing this equipment.

WARNING



- The hazards shown on the following pages may occur during the normal use of this equipment.

Repairs may only be performed by personnel authorized by Carlisle Fluid Technologies.

AREA Tells where hazards may occur.	HAZARD Tells what the hazard is.	SAFEGUARDS Tells how to avoid the hazard.
<p>Spray Area</p> 	<p>Fire Hazard</p> <p>Improper or inadequate operation and maintenance procedures will cause a fire hazard.</p> <p>Protection against inadvertent arcing that is capable of causing fire or explosion is lost if any safety interlocks are disabled during operation. Frequent Power Supply or Controller shutdown indicates a problem in the system requiring correction.</p>	<p>Fire extinguishing equipment must be present in the spray area and tested periodically.</p> <p>Spray areas must be kept clean to prevent the accumulation of combustible residues.</p> <p>Smoking must never be allowed in the spray area.</p> <p>The high voltage supplied to the atomizer must be turned off prior to cleaning, flushing, or maintenance.</p> <p>Spray booth ventilation must be kept at the rates required by NFPA 33, EN 16985, country, and local codes. In addition, ventilation must be maintained during cleaning operations using flammable or combustible solvents.</p> <p>Electrostatic arcing must be prevented. Safe sparking distance must be maintained between the parts being coated and the applicator. A distance of 1 inch (25mm) for every 10KV of output voltage is required at all times.</p> <p>Test only in areas free of combustible material. Testing may require high voltage to be on, but only as instructed.</p> <p>Non-factory replacement parts or unauthorized equipment modifications may cause fire or injury. If used, the key switch bypass is intended for use only during setup operations. Production should never be done with safety interlocks disabled.</p> <p>The paint process and equipment should be set up and operated in accordance with NFPA 33, NEC, OSHA, local, country, and European Health and Safety Norms.</p>

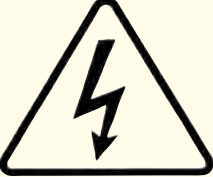
<p>AREA Tells where hazards may occur.</p>	<p>HAZARD Tells what the hazard is.</p>	<p>SAFEGUARDS Tells how to avoid the hazard.</p>
<p>Spray Area</p> 	<p>Explosion Hazard</p> <p>Improper or inadequate operation and maintenance procedures will cause a fire hazard.</p> <p>Protection against inadvertent arcing that is capable of causing fire or explosion is lost if any safety interlocks are disabled during operation.</p> <p>Frequent Power Supply or Controller shutdown indicates a problem in the system requiring correction.</p>	<p>Electrostatic arcing must be prevented. Safe sparking distance must be maintained between the parts being coated and the applicator. A distance of 1 inch (25mm) for every 10KV of output voltage is required at all times.</p> <p>Unless specifically approved for use in hazardous locations, all electrical equipment must be located outside or applicable county code hazardous areas, in accordance with NFPA 33.</p> <p>Test only in areas free of flammable or combustible materials.</p> <p>The current overload sensitivity (if equipped) MUST be set as described in the corresponding section of the equipment manual. Protection against inadvertent arcing that is capable of causing fire or explosion is lost if the current overload sensitivity is not properly set. Frequent power supply shutdown indicates a problem in the system which requires correction.</p> <p>Always turn the control panel power off prior to flushing, cleaning, or working on spray system equipment.</p> <p>Before turning high voltage on, make sure no objects are within the safe sparking distance.</p> <p>Ensure that the control panel is interlocked with the ventilation system and conveyor in accordance with NFPA-33, EN 16985.</p> <p>Have fire extinguishing equipment readily available and tested periodically.</p>
<p>General Use and Maintenance</p> 	<p>Improper operation or maintenance may create a hazard.</p> <p>Personnel must be properly trained in the use of this equipment.</p>	<p>Personnel must be given training in accordance with the requirements of NFPA 33.</p> <p>Instructions and safety precautions must be read and understood prior to using this equipment.</p> <p>Comply with appropriate local, state, and national codes governing ventilation, fire protection, operation maintenance, and housekeeping. Reference OSHA, NFPA 33, EN Norms and your insurance company requirements.</p>

AREA Tells where hazards may occur.	HAZARD Tells what the hazard is.	SAFEGUARDS Tells how to avoid the hazard.
<p>Spray Area / High Voltage Equipment</p> 	<p>Electrical Discharge</p> <p>There is a high voltage device that can induce an electrical charge on ungrounded objects which is capable of igniting coating materials.</p> <p>Inadequate grounding will cause a spark hazard. A spark can ignite many coating materials and cause a fire or explosion.</p>	<p>Parts being sprayed and operators in the spray area must be properly grounded.</p> <p>Parts being sprayed must be supported on conveyors or hangers that are properly grounded. The resistance between the part and earth ground must not exceed 1 Meg Ohm. (Refer to NFPA 33, EN 16985.)</p> <p>Operators must be grounded. Grounding straps on wrists or legs may be used to assure adequate ground contact.</p> <p>Footware to be used by operator shall comply with EN ISO 20344, resistance not to exceed 100 Meg Ohm. Protective clothing including gloves should comply with EN 1149-5, resistance not to exceed 100 Meg Ohm.</p> <p>Operators must not be wearing or carrying any ungrounded metal objects.</p> <p>When using an electrostatic handgun, operators must assure contact with the handle of the applicator via conductive gloves or gloves with the palm section cut out.</p> <p>NOTE: REFER TO NFPA 33, EN 16985 OR SPECIFIC COUNTRY SAFETY CODES REGARDING PROPER OPERATOR GROUNDING.</p> <p>All electrically conductive objects in the spray area, with the exception of those objects required by the process to be at high voltage, must be grounded. Grounded conductive flooring must be provided in the spray area.</p> <p>Always turn off the power supply prior to flushing, cleaning, or working on spray system equipment or applicable county code.</p> <p>Unless specifically approved for use in hazardous locations, all electrical equipment must be located outside or applicable country code, hazardous areas, in accordance with NFPA 33.</p> <p>Avoid installing an applicator into a fluid system where the solvent supply is ungrounded.</p> <p>Do not touch the applicator electrode while it is energized.</p>

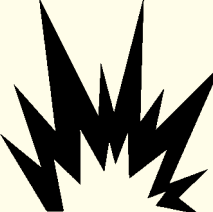
<p>AREA Tells where hazards may occur.</p>	<p>HAZARD Tells what the hazard is.</p>	<p>SAFEGUARDS Tells how to avoid the hazard.</p>
<p>Electrical Equipment</p> 	<p>Electrical Discharge</p> <p>High voltage equipment is utilized in the process. Arcing in the vicinity of flammable or combustible materials may occur. Personnel are exposed to high voltage during operation and maintenance.</p> <p>Protection against inadvertent arcing that may cause a fire or explosion is lost if safety circuits are disabled during operation.</p> <p>Frequent power supply shut-down indicates a problem in the system which requires correction.</p> <p>An electrical arc can ignite coating materials and cause a fire or explosion.</p>	<p>Unless specifically approved for use in hazardous locations, the power supply, control cabinet, and all other electrical equipment must be located outside or applicable country codes, hazardous areas in accordance with NFPA 33 and EN 16985.</p> <p>Turn the power supply OFF before working on the equipment.</p> <p>Test only in areas free of flammable or combustible material.</p> <p>Testing may require high voltage to be on, but only as instructed.</p> <p>Production should never be done with the safety circuits disabled.</p> <p>Before turning the high voltage on, make sure no objects are within the sparking distance.</p>
<p>Toxic Substances</p> 	<p>Chemical Hazard</p> <p>Certain materials may be harmful if inhaled, or if there is contact with the skin.</p>	<p>Follow the requirements of the Safety Data Sheet supplied by coating material manufacturer.</p> <p>Adequate exhaust must be provided to keep the air free of accumulations of toxic materials. Reference EN 12215 or applicable code.</p> <p>Use a mask or respirator whenever there is a chance of inhaling sprayed materials. The mask must be compatible with the material being sprayed and its concentration. Equipment must be as prescribed by an industrial hygienist or safety expert, and be NIOSH approved.</p>
<p>Spray Area</p> 	<p>Explosion Hazard — Incompatible Materials</p> <p>Halogenated hydrocarbon solvents for example: methylene chloride and 1,1,1, - Trichloroethane are not chemically compatible with the aluminum that might be used in many system components. The chemical reaction caused by these solvents reacting with aluminum can become violent and lead to an equipment explosion.</p>	<p>Spray applicators require that aluminum inlet fittings be replaced with stainless steel.</p> <p>Aluminum is widely used in other spray application equipment - such as material pumps, regulators, triggering valves, etc. Halogenated hydrocarbon solvents must never be used with aluminum equipment during spraying, flushing, or cleaning. Read the label or data sheet for the material you intend to spray. If in doubt as to whether or not a coating or cleaning material is compatible, contact your coating supplier. Any other type of solvent may be used with aluminum equipment.</p>

INTRODUCTION

FEATURES

Features which make the **TurboDisk™ Applicator** advantageous for use in electrostatic applications include:

- Proven turbine motor reliability.
- Aerodynamic fairing design for ease of cleaning of external surfaces.
- Speed readout (or control) uses reliable magnetic pickup for fiber optic transmission of rotational speed data (optional).
- A majority of all assembly components which come in contact with the fluid material are made of stainless steel, which is impervious to most fluids.
- Negligible maintenance down time.
- The easily removable lower fairing, turbine air motor assembly, and the externally mounted regulators and fluid valves, make off line maintenance more efficient and economical.
- Higher fluid delivery rates can be achieved using a dual feed fluid system.
- High flow regulators and fluid valves provide for simultaneous paint push out while solvent washes the feed tube and disk.

GENERAL DESCRIPTION

The TurboDisk Applicator, because of its high rotational speed, produces finer atomization, improved quality, and higher transfer efficiency with any of the wide variety of coating materials (such as waterborne and high solids) used in production finishing operations. Its speed is controlled by varying the drive air. The applicator assembly is designed for use on vertical overhead mounted reciprocators.

Conical Disk Assembly

The TurboDisk Applicator uses conical disk assemblies that are made from high grade aluminum construction and are

force balanced to .10 grams•in or better. With the serrated edge, these disks come in sizes of 6, 9, and 12 inch diameters.

TurboDisk Fairing (Refer to Figure 17)

The TurboDisk Applicator fairing is required for safe operation. The two piece fairing provides high voltage isolation from the metal rotator assembly and valve components, as well as ease of cleaning and maintenance. (152mm, 229mm and 305mm)

WARNING

- Both sections of the fairing to be in place when the TurboDisk is in operation or when high voltage is supplied to the applicator.

Paint Valve Options

Several valve options are available for both single and dual feed.

Options are:

- No Valves
- 3-Way Valves
- Trigger and Dump Valves with DR-1 Regulator
- Trigger Valve Only
- Trigger and Dump Valves with Dual DR-1 Regulators
- Trigger Valves with DR-1 Regulator

Power Supply and Controls

In the system, the high voltage is supplied to the TurboDisk by the MicroPak2e Industrial power supply system or a Voltage Master™ series power supply.

The MicroPak2e Industrial power supply uses proven high voltage generator technology that is microprocessor controlled for diagnostics and communication.

The Voltage Master™ power supplies are general purpose heavy duty power supplies with years of proven reliability. They have variable voltage control, many safety features, and remote analog voltage control capabilities.

APPROVALS

For end users in countries which require an ATEX approval, the use of solvent based materials is not permitted with this product. For applications using waterbased materials this product is CE approved according to the guidelines of 2006/42/EC machinery directive. It is the end users responsibility to abide by these requirements.

For definition of waterbase materials reference EN 50348: ANNEX A or EN 50059: 2018 ANNEX C.

For further information reference EN 50348 for protection requirements.

For end users that do not require an approved applicator, reference the applicable code requirements for safe use. (Ref. NFPA 33)

SPECIFICATIONS

Mechanical

Turbine Speed:	Variable to 40,000 rpm max. (6-inch conical disk, 152mm) Variable to 25,000 rpm max. (9-inch conical disk, 229mm) Variable to 15,000 rpm max. (12-inch conical disk, 305mm)
Turbine Type:	Ball Bearing
Weight:	57-lbs. (25.9 Kg) (approximately)
Length:	36-inches (915mm)
Diameter:	13.25-inches (337mm)
Turbine Air:	At max. speed (40k rpm), requires 103.1 psi and 61.1 SCFM, unloaded (See "Typical Speed Chart" in this section.) (7.1 bar and 1727 SLPM)
Air Temp °F:	120°F maximum at applicator (48.9° C)
Fluid Pressure Inlet:	(See "Fluid and Air Pressure Regulator" in the "Operation" section.)
Single Fluid Flow Range:	
Waterborne:	To 1,200 cc/min. maximum
Solvent Base:	To 1,500 cc/min. maximum
High Solids:	To 1,000 cc/min. (80%+) maximum
Air Inlet Trigger / Dump:	70-100 psi (4.8 to 6.9 bar)
Air Pilot for Fluid Pressure:	(See "Fluid and Air Pressure Regulator" in the "Operation" section.)

Electrical

Power Supply Type:	MicroPak2e Industrial or Voltage Master™
Charging Method:	Direct
Input Voltage:	0-100 kV
Turbine Speed Control or Monitor:	MicroPak 2e PulseTrack 2(Optional)

WARNING

➤ This product is **NOT** ATEX approved for use with solvent based materials

TYPICAL SPEED CHART (RPM'S NO LOAD)

(Refer to "Typical Speed Chart")

The following represents data collected under lab conditions. Flow meters were installed on each of the two 3/8-inch ID heated air lines used to supply the TurboDisk turbine motor. The airflow through each flow meter was recorded and added together to obtain the total air flow through the system. The speed of the disk was monitored through the means of a PulseTrack system. The air heater was set at 120 degrees during all data collection.

Rotational speeds are unloaded and can be expected to drop 20 to 30% when under a fluid load condition. Heated turbine air increases efficiency of motor up to 10%. This chart should be used as a guide ONLY. Speeds will vary due to rotator wear, tubing size or lengths, etc.

⚠ WARNING

- ▶ Never run disk over it's maximum safe operating speed depending on disk diameter.

NOTE

- ▶ Air heater removes condensation from OD of motor at high speeds.

TYPICAL SPEED CHART - 10 HOLE ORIFICE PLATE (NO LOAD)

6" CONICAL DISK

Disk Speed (RPM)	Supply Air Pressure (PSI/BAR)	Air Flow #1 (SLPM)	Air Flow #2 (SLPM)	Total Air Flow (SLPM)	Total Air Flow (SCFM)
5,000	6.6 / 6.45	140	100	240	8.5
10,000	10.5 / 6.72	190	140	330	11.7
15,000	18.2 / 1.25	260	200	460	16.2
20,000	27.8 / 1.92	340	260	600	21.2
25,000	40.4 / 2.79	440	350	790	27.9
30,000	56.3 / 3.88	560	460	1,020	36.0
35,000	76.4 / 5.27	730	610	1,340	47.3
40,000	103.1 / 7.11	930	800	1,730	61.1

9" CONICAL DISK

Disk Speed (RPM)	Supply Air Pressure (PSI/BAR)	Air Flow #1 (SLPM)	Air Flow #2 (SLPM)	Total Air Flow (SLPM)	Total Air Flow (SCFM)
5,000	11.3 / 0.78	200	140	340	12.0
10,000	26 / 1.79	330	250	580	20.5
13,000	39.5 / 2.72	430	340	770	27.2
16,000	55.4 / 3.82	560	460	1,020	36.0
19,000	79.8 / 5.50	760	640	1,400	49.4
22,000	102 / 7.03	930	800	1,730	61.1

12" CONICAL DISK					
Disk Speed (RPM)	Supply Air Pressure (PSI/BAR)	Air Flow #1 (SLPM)	Air Flow #2 (SLPM)	Total Air Flow (SLPM)	Total Air Flow (SCFM)
2,000	8.7 / 0.78	170	120	290	10.2
4,000	18.6 / 1.28	270	200	470	16.6
6,000	31.0 / 2.14	370	290	660	23.3
8,000	48.3 / 3.33	500	400	900	31.8
10,000	68.5 / 4.72	670	560	1,230	43.4
12,000	95.8 / 6.61	880	750	1,630	57.6
12,500	102.0 / 7.03	930	780	1,710	60.4

INSTALLATION

In waterbase applications, the isolated fluid source is charged. This charge can produce energy greater than 350 mj. It is highly recommended a ground switch be installed to discharge this energy safely to ground.

EQUIPMENT

This system should be installed by, or under the supervision of an Ransburg representative. Should the need arise to replace any component assembly within the system, contact your Ransburg representative.

This manual concerns normal operation, maintenance, and service of the specified applicator assemblies. The air and fluid connections vary with different models and installations. This manual deals primarily with those at, or within the assembly.

AIR CONTROL

(Refer to Figure 1)

Air control of the applicator is from a standard Ransburg air logic panel, which includes two filters (one 40 micron filter located at the air logic station and one 5 micron filter located at the inlet of the in-line air heater panel). Clean, dry factory air must be provided to the inlet filter of the air logic station via a minimum 1/4-inch ID pipe and to the inlet filter of the heater panel via a minimum 3/4-inch ID pipe.

⚠ WARNING

- The Air Heater Assembly must be located outside of any hazardous areas as defined by the NFPA-33, EN 16985.

⚠ WARNING

- **NEVER** wrap the applicator in plastic to keep it clean. A surface charge may build up on the plastic surface and discharge to the nearest grounded object. Efficiency of the applicator will also be reduced and damage or failure of the applicator components may occur. **WRAPPING THE APPLICATOR IN PLASTIC WILL VOID WARRANTY.**

MOUNTING

(Refer to Figure 16)

The TurboDisk assembly is mounted on the reciprocator using four (4) 5/16-18 screws provided on the ram flange. Loosening two (2) 1/4-20 screws on the same ram flange will allow the assembly to rotate. Position the TurboDisk assembly so that the strain relief boot is positioned toward the incoming fluid and air lines and retighten.

Remove lower fairing. Thread all the required air, high voltage, fiber optic, and fluid service lines through the strain relief boot. The strain relief boot may have to be cut larger in order to feed all the lines through.

Reinstall lower fairing. Install conical disk and torque to 50-70 lbs•in (5.65-7.91 Nm).

INTERLOCKS

Flow of coating material should be locked out unless all of the following conditions are met:

1. Booth exhaust is turned on.
2. The turbine must be spinning prior to any fluid flow.
3. High voltage is on or in the bypass mode.

Voltage Interlocks

1. High voltage must be interlocked with solvent valve pilot to prevent solvent flow while voltage is energized.
2. High voltage must be interlocked with booth or other electrical sensing means that prevents human entry near the applicator. Reference EN 61496-1, EN 61496-2, and EN ISO 13856-1 for further information.

Other Interlocks

1. Any additional interlocks required by local code, national code, or international code.

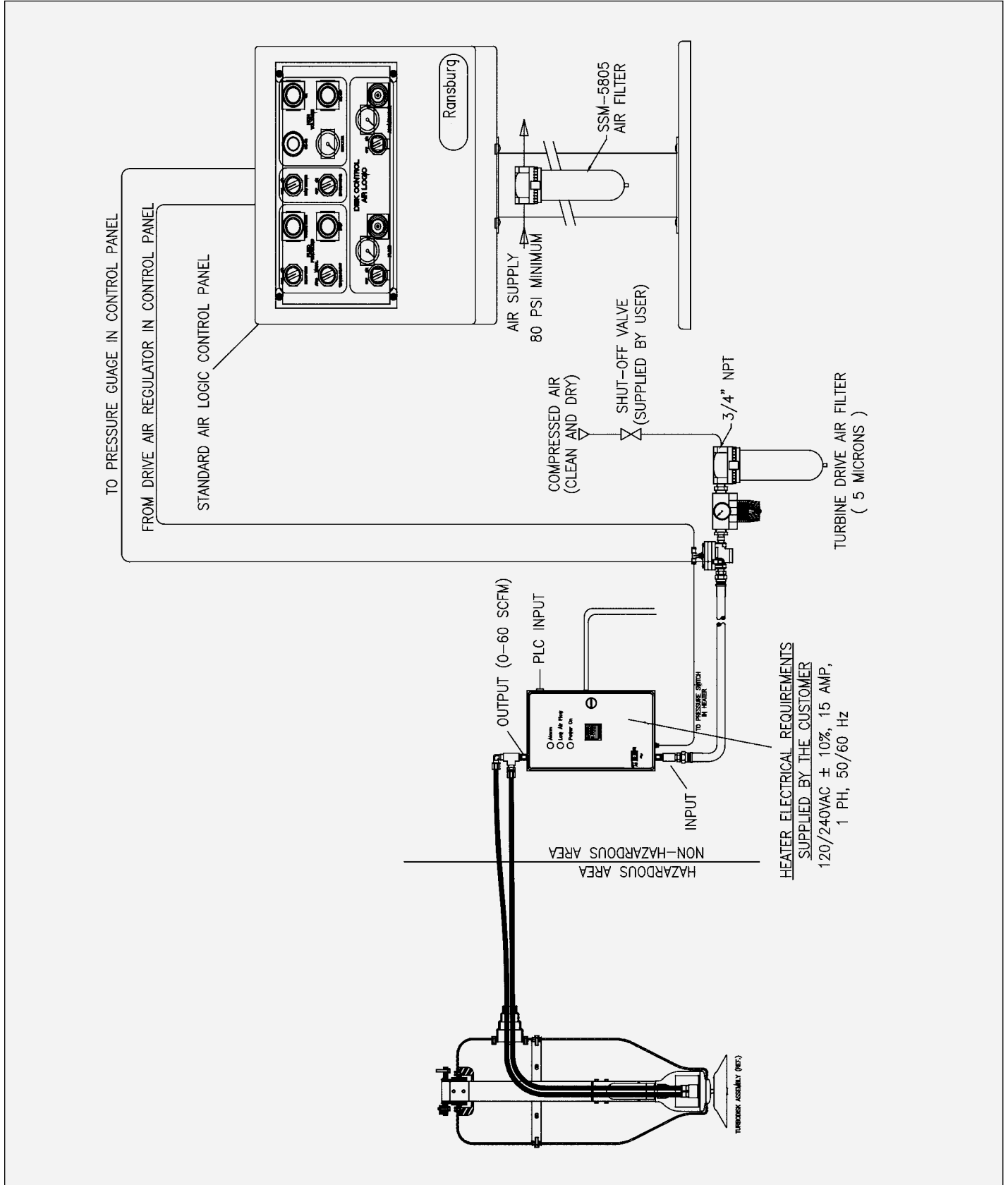

Figure 1: Typical Layout of System

OPERATION

⚠ CAUTION

- Fluids and lubricants used in this system must contain NO silicones!
- Do **NOT** operate the unit without an atomizer disk! Without a disk, overspeed, resulting in premature bearing failure, is possible.
- The air supplied to the motor must be dry, clean, and free of oil or moisture. The atmospheric dew point should be 10°F (-12.2° C) or less. The air heater used should be adjusted only high enough to prevent condensation from forming on the motor housing or at the exhaust port.

⚠ WARNING

- Operators must be fully trained in safe operation of electrostatic equipment. Operators must read all instructions and safety precautions prior to using this equipment (see NFPA-33).

As with any spray finishing system, operation of the TurboDisk involves properly setting the operating parameters to obtain the best finish quality for the coating material being sprayed, while maintaining correct operation and reliability of the equipment used. Adjustments to operating parameters, which cover spraying, cleaning, and on/off control, include:

- Fluid Type
- Fluid Flow Rate
- Turbine Speed
- Electrostatic Voltage
- Target Distance

⚠ WARNING

- DO NOT exceed the maximum flow rate of 1500 cc/min. during painting or purge cycles. Excessive fluid flow may cause an imbalance condition and possibly premature bearing failure.

AIR HEATER REQUIREMENTS

Turbine drive air expands as it moves through the turbine wheel cavity and as it exits the turbine from the exhaust port. This expansion will cause cooling of the exhaust air and the surfaces it contacts. This cooling effect can cause surface temperatures to fall below the dew point of the booth, which will result in condensation on the interior and exterior of the atomizer, machine, and its components. It is even possible that the temperature of the supply air may be below the booth dew point, even without additional expansion cooling.

Condensation is especially probable in waterborne applications when booth temperature and relative humidity levels are typically maintained very high. This condensation will allow sufficient conductivity of the surfaces such that they act as an erratic ground source potential. This can cause damage to the equipment.

It is therefore a requirement that turbine exhaust air temperature be maintained about the booth dew point to prevent condensation from forming on atomizer surfaces. Doing so will eliminate moisture as a potential defect in painted surfaces as well as extending equipment life. Thus, it is recommended that air heaters be installed into the atomizer air supply lines, i.e. turbine drive air. The air heaters must be of sufficient capacity, capable of raising the incoming air temperature to at least 40°F (4.4°C) at a flow rate of 60 SCFM per applicator.

The actual air heater process setting depends on the applicator fluid flow rate load, booth conditions, turbine airflow settings, and incoming air temperature.

The heater should be set as low as possible, sufficient to maintain the applicator surface temperatures above the dew point in the booth.

Example: Only with the incoming air temperature at 72°F (22.2°C), a disk rotating unloaded at 30 krpm has a turbine outlet temperature drop to approximately 28°F (-2.2°C) (@ 40 krpm unloaded, 14°F). Referring to the ASHRAE Psychrometric chart, the saturation temperature range (dew point) of a spray booth maintained at 70-75°F / 65-70% RH is 62-68°F (21.1-23.9°C / 65-70% RH is 16.7-20°C). Thus, it is almost certain that the surface

temperatures of the applicator will fall below the dew point of the booth, and an air heater will be needed in this case.

To prevent condensation, an air heater assembly should be assembled after air filters. (Reference the current "Air Heater Assembly" service manual for further information.)

NOTE

- Failure to use an air heater may cause damage to equipment or ruin the finished component being processed.

COATING MATERIALS

The TurboDisk can be used with a broad range of coating material conductivities. However, with waterborne paints, it may be necessary to isolate the paint supply from ground.

⚠ WARNING

- Isolated fluid supplies using either waterborne or highly conductive solvent base coatings can produce hazardous high voltage discharges which can cause fires or injury to personnel.

FLUID FLOW CONTROL

Fluid flow control is dependent on the valve configuration of the TurboDisk. If the TurboDisk is configured with no valves or a 3-way valve, fluid flow is controlled externally at the paint source. If the TurboDisk is equipped with a regulator, fluid flow can be controlled via the air pilot signal. The high flow and low flow regulators each have procedures on how to control and deliver consistent fluid flows. For more information on controlling the fluid delivery using regulators, refer to that specific manual which is included with the system.

To check fluid flow rates, the disk must be removed. See the "Maintenance" section for "Removal Procedure". The fluid can then be manually triggered to measure actual flow in a graduated beaker over a specified time period.

⚠ WARNING

- Danger of shock and/or personal injury can occur. Proper grounding procedures, which are outlined in the Ransburg safety bulletins, must be followed. Personnel must never work near or perform work on the turbine when the turbine is spinning or when high voltage is on.

FLUID VALVE CONTROL

Trigger and Dump (Refer to "TurboDisk Fluid and Air Pressure Requirements")

The fluid valves in the TurboDisk are actuated by an air signal. The air pressure must exceed 70 psi to assure proper actuation of the valve. Applying air to the valve actuator turns on the fluid flow for that valve.

The trigger valve controls the paint flow to the disk. When actuated, paint flows through the valve to the fluid tube. The disk should be spinning at an rpm speed that is fast enough, (that when fluid is turned on) to enable the fluid to flow through the disk paint passage holes and be atomized.

The dump valve controls the paint flow through the dump line. When actuated, paint flow is directed to the dump return line. This provides a method of rapidly removing paint from the incoming line for cleaning and/or color change. Normally, the dump valve is not actuated at the same time as the paint trigger valve since the trigger valve is intended to cause the fluid flow to the disk at the prescribed input pressure.

FLUID AND AIR PRESSURE REQUIREMENTS

(Refer to "TurboDisk Fluid and Air Pressure Requirements")

Fluid and air pressure requirements are dependent on the fluid trigger valve configuration.

TURBODISK FLUID AND AIR PRESSURE REQUIREMENTS

	No Valves	3-Way ON/OFF (18283)	Trigger/Dump W/High Flow (70171-04) Regulator	Trigger/Dump W/Low Flow DR-1 (74151) Regulator
Air Pilot Fluid Regulator	---	---	100 psi max.	100 psi
Air Inlet Trigger/Dump Valve	---	120 psi max.	70-100 psi	70-100 psi
Fluid Inlet Pressure	---	300 psi max.	80-100 psi max.	80-100 psi max.
Solvent Inlet	---	30-60 psi max.	30-60 psi max.	30-60 psi max.

Note: Trigger/dump valves (CCV-403-SS) are rated to 300 psi maximum inlet fluid pressure but are limited to the lower pressure limit of the fluid regulators.

TURBINE SPEED

Turbine speed is determined by the drive air pressure at the rotary atomizer and fluid flow rate.

Turbine speed can be closed loop controlled using the fiber optic speed transmitter mounted at the back of the turbine rotor assembly as a speed input to remote speed controls such as the PulseTrack 2.

Atomizers

(Refer to "Typical Maximum Safe Operating Speeds")

NOTE

- The disk rotational speed determines the quality of atomization and can be varied for different flow rates and viscosities. For optimum transfer efficiency and spray pattern control, the disk rotational speed should be set at the minimum required speed to achieve proper atomization.
- **Excessive speed reduces transfer efficiency!**

⚠ WARNING

- Do not exceed the maximum rated speed of 40,000 rpm for the 6 inch conical disk and 27,000 rpm for the 6 inch uni-disk. This maximum speed includes speed overshoot when fluid delivery is stopped. Damage to persons or equipment may result from over-speed conditions.

⚠ WARNING

- Never operate any disk atomizer in excess of its maximum rated speed ("K" number) as listed in the service manual. Excessive speed may cause the disk to disintegrate, causing serious damage and/or injury.

All atomizers manufactured after April 6, 1982, bear a "K" number. That number indicates the maximum safe rotation speed for that series in tens of thousands.

For example:

9K = 9,000 rpm maximum safe speed,
40K = 40,000 rpm, etc.

If you have an atomizer that does not have a "K" number, contact your Ransburg representative for its maximum safe operating speed.

⚠ WARNING

- Inspect disk platter daily for wear or damage. Replace if excessively worn or damaged. Worn or damaged disk platters can cause an imbalanced condition and shorten bearing life. Warranty will be voided if damaged disks are used.

TYPICAL MAXIMUM SAFE OPERATING SPEEDS

Disk Type	Part Number	Max. RPM
None	---	---
Conical Disk Assy., Serrated, 6", Aluminum, Not Anodized	20485-62	40,000
Conical Disk Assy., Serrated, 6" Aluminum, Anodized	20485-65	40,000
Conical Disk Assy., Serrated, 9", Aluminum, Not Anodized	20485-92	25,000
Conical Disk Assy., Serrated, 9", Aluminum, Anodized	20485-95	25,000
Conical Disk Assy., Serrated, 12", Aluminum, Not Anodized	20485-122	15,000
Conical Disk Assy., Serrated, 12", Aluminum, Anodized	20485-125	15,000
Uni-Disk Assy., 6", Aluminum, Not Anodized	19830-06	27,000
Uni-Disk Assy., 8", Aluminum, Not Anodized	19830-08	23,000
Uni-Disk Assy., 10", Aluminum, Not Anodized	19830-10	15,000
Uni-Disk Assy., 12", Aluminum, Not Anodized	19830-12	15,000

ELECTROSTATIC VOLTAGE

In the system, the high voltage is supplied to the TurboDisk by either the MicroPak/MicroPak2e Industrial power supply system or Voltage Master series power supplies.

The MicroPak/MicroPak2e industrial power supply uses proven high voltage generator technology that is microprocessor controlled for diagnostics and communication. The controller is packaged in standard rack mounted Eurocard format for easy access and system integration.

The Voltage Master power supplies are general purpose heavy duty power supplies with years of proven reliability. They have variable voltage control, many safety features, and remote analog voltage control capabilities.

TARGET DISTANCE

The distance between the TurboDisk and the target will affect the finish quality, penetration, and efficiency. Closer distances give wetter finishes and greater efficiency, while greater distances give drier finishes. The recommended normal disk edge to target range is 12-inches (305mm) minimum for optimum performance.

MAINTENANCE

GENERAL

Verify daily that the operating parameters have not varied dramatically. A sudden change or even a gradual decay in performance could be early indications of component failure.

Normal maintenance procedures should be established and recorded at the initial start-up. All maintenance schedules are subject to variation based on use. Periodically review these maintenance schedules as equipment ages and needs change.

CLEANING PROCEDURES

⚠ WARNING

- Electrical shock and fire hazards can exist during maintenance. The power supply must be turned off before entering the spray area. Spray booth fans should remain on while cleaning with solvents.
- Never touch the disk atomizer while it is spinning. The edge of the disk can easily cut into human skin, gloves or other materials. Be sure the disk atomizer has completely stopped spinning before attempting to touch it. Approximate time for the disk to stop spinning after turning off the drive air is about four minutes.

In addition to the above Warning, which relates to potential safety hazards, the following information must be observed to prevent damage to the equipment.

⚠ CAUTION

- Because of the hazard of bearing penetration, solvents should be used sparingly! They should **NEVER** be hosed directly onto the atomizer, motor housing, or any fiber optic juncture.

⚠ WARNING

- Prior to servicing ensure all voltage has been discharged to ground. For waterbase applications ensure all voltage is discharged to ground either by waiting for all voltage to decay (depend on installation) or use a ground switch installed in the system.

⚠ WARNING

- **NEVER** wrap the applicator in plastic to keep it clean. A surface charge may build up on the plastic surface and discharge to the nearest grounded object. Efficiency of the applicator will also be reduced and damage or failure of the applicator components may occur. **WRAPPING THE APPLICATOR IN PLASTIC WILL VOID WARRANTY.**

⚠ CAUTION

- **Do not** immerse the TurboDisk assembly in solvent or other liquids. Turbine components will be damaged.
- **Do not** soak the disk in solvent longer than 24 hours.

⚠ WARNING

- Inspect disk platter daily for wear or damage. Replace if excessively worn or damaged. Worn or damaged disk platters can cause an imbalanced condition and shorten bearing life. Warranty will be voided if damaged disks are used.

Internal Fluid Path Cleaning

With the high voltage turned off and the disk spinning, flush cleaning solvent through the incoming paint line or through the solvent inlet line. If it is desired to clean just the face of the disk off, flush solvent through the solvent inlet. If a color change is required, flush the entire system. The spinning disk will atomize the solvent and clean out the disk passages. If equipped, trigger the dump valve to catch the wasted paint from the incoming line, then flush the disk with solvent after closing the dump valve.

⚠ WARNING

- Never submerge a disk into a solvent bath while still mounted on the shaft. Solvent may intrude into bearing cavity and destroy the grease. Remove disk to hand clean or run disk and flush through trigger and dump valves.

NOTE

- Solvent flushing of the system (except during color change) should be done with the disk dismounted and with waste solvent collected in a grounded container.

External Atomizer Surface Cleaning**⚠ WARNING**

- When using solvents for cleaning:
 - Those used for equipment flushing should have flash points equal to or higher than those of the coating material.
 - The flash point of the cleaning solvent shall be at least 15° C (27° F) above the ambient temperature. Otherwise, the cleaning process must be carried out in an area with forced air ventilation. It is the end users responsibility to ensure this condition is met.
- Since electrostatic equipment is involved, these solvents should also be nonpolar. Examples of nonflammable, nonpolar solvents for cleaning are: Amyl acetate, methyl amyl acetate, high flash naphtha and mineral spirits.
- Do not use conductive solvents such as MEK to clean the external surfaces of the TurboDisk.
- Never lower the TurboDisk assembly into a drum for flushing or color changing.

Disk Cleaning

Normally, the internal cleaning instructions will suffice to clean the disk. If flushing the disk does not remove all the residue, the disk may be removed for hand cleaning. Unscrew mounting nut and remove the disk by using the supplied disk puller.

NOTE

- The turbine shaft must be held with a 7/16" open end wrench while using the disk puller.

⚠ WARNING

- Do not hold disk edge during removal. This could result in injury.

Inspection of the disk is required to determine if wear to the serrated edge or damage has occurred. Wear can cause a reduction in transfer efficiency and excessive paint wrap on the atomizer fairing.

Clean the disk by soaking in an appropriate solvent to loosen paint residue. Do not soak for more than a 24 hour period. Use a soft cloth to remove the paint from the surface and a soft bristle brush to remove paint from the well area. The splash plate may need to be removed to clean the paint well. The screws must be retorqued to 24 lbs•in (2.71 Nm) after cleaning.

Reinstall the disk and torque the mounting nut to 50-60 lbs•in (5.65-6.78 Nm).

⚠ WARNING

- Do not attempt to clean the disk edge while it is rotating. Do not attempt to slow down or stop the disk by holding a rag or a gloved hand against the edge. This could cause physical harm and/or damage to the disk.

⚠ WARNING

- Replace disk platter if damaged. Warranty will be voided if damaged dish platter is used.

⚠ WARNING

- Inspect disk platter daily for wear or damage. Replace if excessively worn or damaged. Worn or damaged disk platters can cause an imbalanced condition and shorten bearing life. Warranty will be voided if damaged disks are used.

⚠ CAUTION

- Do not use abrasive materials which will scratch or damage the disk. Cleaning pads such as Scotch-Brite® should not be used.
- Using an atomizer disk with paint buildup may cause an imbalance. This may result in bearing damage and turbine failure. This condition may also stress the disk when operating at high speeds.
- Before reinstalling the disk onto the shaft, check and clean the tapered mating surface for paint residue.
- Care must be taken when mounting the disk assembly to the motor shaft. The mounting nut should turn freely for several turns until it fully bottoms on the disk assembly. Tighten to 50-70 lbs•in (5.65-7.91 Nm).

PREVENTIVE MAINTENANCE

Before any shutdown or maintenance, the fluid system should be thoroughly flushed. All cleaning should be done with a minimum of the appropriate clean solvent and clean, soft, lint free rags or soft brushes where indicated.

⚠ WARNING

- Do not stop disk rotation by using a rag or gloved hand.
- Make sure high voltage is off before approaching applicator.
- Follow proper grounding procedures.

VIBRATION NOISE

If the TurboDisk is vibrating or making an unusual loud noise, it may mean that there is an unbalanced situation or a bearing failure. The disk could have dried paint or could be damaged. This situation should be corrected immediately. Do not continue to operate a noisy turbine.

⚠ CAUTION

- Because of the hazard of bearing penetration, solvents should be used sparingly. They should never be hosed directly onto the atomizer, motor housing or fiber optic juncture.

⚠ WARNING

- If a disk has been mishandled or there appears to be damage on the face, DO NOT USE. Serious injury can result from rotating a defective disk. If there is a concern about the condition of a disk, please return it to Ransburg for evaluation.

⚠ WARNING

- Personnel working on applicators **MUST** always be sure that the high voltage is off, the fluid system is flushed and off, the rotator has stopped, and that the grounding hook has been properly secured to the motor housing.

TURBINE REPAIR AND REBUILD

Turbine motor must be returned to Ransburg for rebuilding.

Any attempt to disassemble turbine during warranty period will void the warranty.

Daily Maintenance

- Clean the atomizer disk, motor housing, fairing, and as needed, the peripheral equipment with nonpolar high flash point solvents.
- To prevent solvent penetration beyond the slinger, a minimal air pressure of 5 to 10 psi should be applied to the motor in order to maintain a positive pressure. The motor should be run at operating speed for several minutes after cleaning to keep any solvent that has accumulated at the seals from penetrating into the motor housing.

VALVES AND REGULATORS

No maintenance is normally required on the valves or regulator other than flushing with solvent daily. Visual inspections should be made on the valves and regulator on a weekly basis. Should the valve or regulator not function properly, refer to the individual manuals for troubleshooting and repair procedures.

⚠ WARNING

- Positive air pressure must be maintained to prevent solvent or paint intrusion into the bearings. Solvent and/or paint will degrade the grease in the bearings and cause failure. Warranty will not cover this!

- Inspect the disk edge and face. If damage exists, DO NOT USE. Return it to Ransburg for evaluation.
- Check the fluid feed tube to make sure it is not rubbing the disk.
- The fluid and solvent supply have been turned off and the pressure has been relieved.
- The high voltage has been turned off and the motor housing grounded.

Weekly Maintenance

Follow the normal daily maintenance schedule, then:

- Monitor rotational speed at the control and verify it is within 5% of target speed.
- Monitor high voltage output indicated on the power supply display. Verify with high voltage probe and meter.
- Remove fairing and clean all internal components: valves, regulators, and tubing. Check tubing for evidence of pin-holes, kinks, and abrasions.
- If the muffler needs to be cleaned (item is to be solvent cleaned) remove it from the motor. Clean and dry the muffler before reinstalling it.
- Check fluid flows by removing the disk and manually triggering the paint valve. Measure the amount of fluid in a graduated beaker over a specific time to determine flow rate.
- Clean and inspect the disk face. Look for wear, which can cause poor transfer efficiency and excessive paint wrap on the atomizer fairing. Disk removal, cleaning and inspection may be done more or less frequently, depending upon use.

DISASSEMBLY PROCEDURES

Prior to disassembly, verify the following:

- The atomizer disk, valves and regulator have been flushed with solvent and purged dry with air.
- The disk has stopped rotating.
- The air supply to the trigger valves and regulator have been turned off.

Turbine Cartridge Exchange

Removal

1. Remove disk mounting nut by holding the rotator shaft above the disk with a 7/16-inch open end wrench and unscrewing the mounting nut with a 3/8-inch Allen wrench.
2. Install the Ransburg 19850-00 disk puller into disk to remove it.
3. Carefully remove lower fairing.

WARNING

- Handle the disk with caution. The sharp edge can cut even though it is not rotating.

4. Next remove screws holding the fluid tube assembly.
5. With a 7/64-inch Allen wrench, remove six (6) socket head cap screws, which secures the turbine cartridge to the motor housing.
6. Using a 1/16-inch Allen wrench, turn each of the three (3) jack screws, located next to socket head cap screw, clockwise not more than one half turn at a time in sequence to separate the motor from the housing.

CAUTION

- Failure to perform this step correctly may result in misalignment and possible damage.
- Use caution in removing cartridge to prevent it from falling out of the housing.

CAUTION

- Any attempt to disassemble turbine during the warranty period will void the warranty.

Installation

Always check the inside of the motor housing and clean, if required, with a minimum amount of an appropriate cleaning solvent and a soft cloth.

1. Using a 1/16-inch Allen wrench, retract the three (3) jack screws.
2. With o-rings in place on the nozzle plate and housing, insert the turbine cartridge into motor housing.

CAUTION

► Lightly lubricate o-rings with petroleum jelly before assembly. Fit parts with o-rings very carefully. They must not be allowed to distort, unseat, or break.

3. Secure the rotator assembly to the housing with six (6) socket head cap screws. Tighten the screws in sequence until the cartridge is fully engaged into the housing to prevent misalignment and possible damage. Torque to 10 lbs•in (1.13 Nm).
4. To avoid losing the jack screws during normal operation, torque to 2-3 lbs•in (0.23-0.34 Nm).

Turbine Cartridge Service

This cartridge is a precision instrument and should be handled with care. The bearings are preloaded to 30 lbs. (13-6 Kg) and dynamically balanced.

Turbine bearing unit must be returned to Ransburg for rebuilding.

CAUTION

► Failure to observe the following cautions will result in diminished performance and premature motor failure.

NOTES:

- Never use any silicone compound in this system!
- Never use any lubrication on the bearings!
- Never use any solvent on the bearings!
- Never exert force on one race of a bearing assembly that may be transmitted to the other race through the bearings! Force and resistance must always be on the same race in order to prevent damage.
- Do not enlarge the nozzle passages during cleaning, as it will effect performance.
- Always observe the specified torque in tightening fasteners.
- Clean all parts thoroughly with an appropriate, clean solvent. Inspect them for wear or damage and replace as required.
- Check all flow passages for obstruction, particularly the nozzle plate. Clear as required.
- Discard o-rings and replace with new. Lightly lubricate o-rings with petroleum jelly before assembly. Fit parts with o-rings very carefully. They must not be allowed to distort, unseat, or break.

TROUBLESHOOTING GUIDE

General Problem	Possible Cause	Solution
Fluctuating Pattern	Not enough back pressure on regulator	See regulator manual for diagnosis.
Light Coverage on Some Parts	Part hangers, hooks, are not clean	a. Clean hangers. b. Check ground continuity. (Must be less than 1 Megohm.)
Poor Transfer Efficiency	Low voltage	Check disk voltage with high voltage probe.
	Disk RPM too high	Slow disk speed.
	Booth flow too high	Reduce booth air flow.
	Disk edge to part distance too great	Decrease conveyor loop diameter.
Low Current Readings	Dirty high voltage contacts	Clean and/or replace.
High Current Readings / Power Supply Overloads	Target distance too close	Check target distance. Ideal target distance is 12-inches minimum.
	Conductive paint	Solventbase paint conductivity should be between .05 and 20 Meg Ohms on Ransburg Paint Test Meter.
	Fairing dirty	Clean with nonpolar solvent.
	High voltage cable break-down	Replace cable.
	Fluid tube pinholed to ground on conductive paint systems	Check tubing routing for areas where fluid tube comes near a ground.
	Isolation mounting rod dirty or carbon tracked	Clean with nonpolar solvent or replace.
Low Voltage	Power supply Faulty high voltage switch or junction tank High voltage cable	Use the following procedure to isolate problem: <ul style="list-style-type: none"> • Verify power supply output. Refer to power supply manual for procedure. • Remove the fairing and measure input voltage to the rotator assembly by removing the high voltage cable from the connector fitting and inserting it into the high voltage probe. If voltage is low, replace high voltage cable with a known good one and retest. • If voltage is still low, check for bad connections in the high voltage Junction or Switch Tank. Refer to procedures in the proper manual. • Reinstall the high voltage cable. Check voltage at the rotator housing.

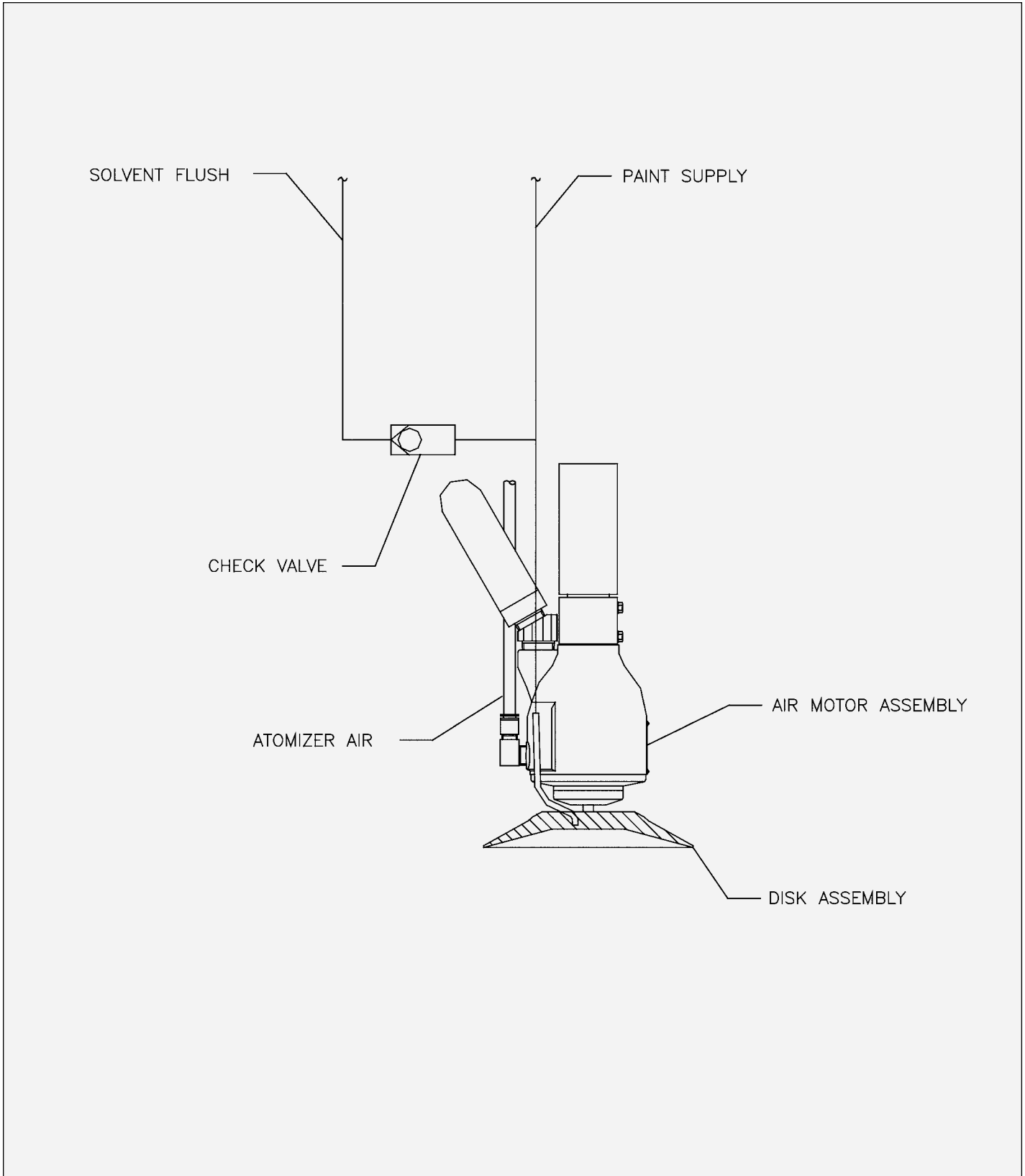

Figure 2: Typical No Valve Application Schematic

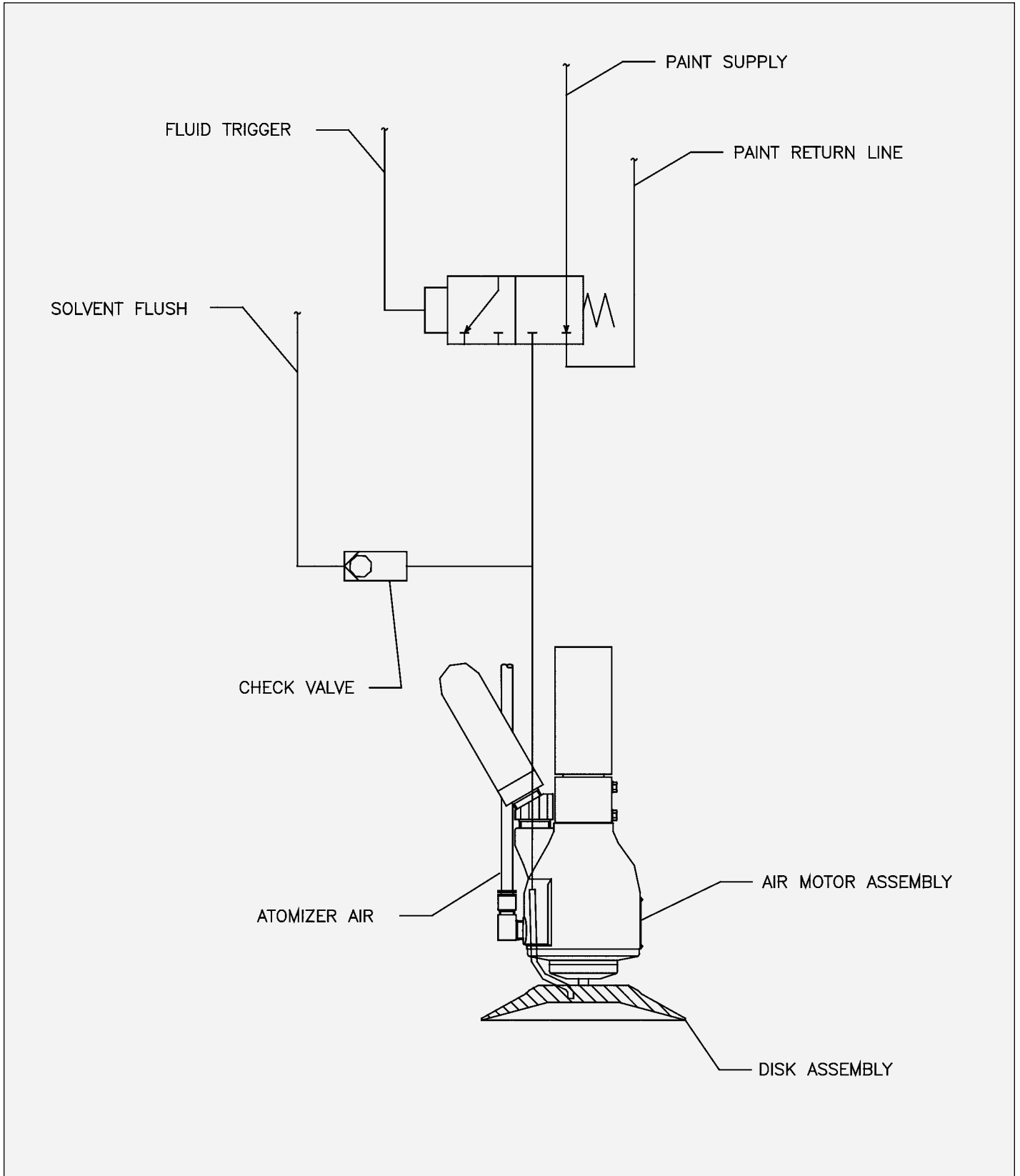

Figure 3: Typical 3-Way Valve Application Schematic

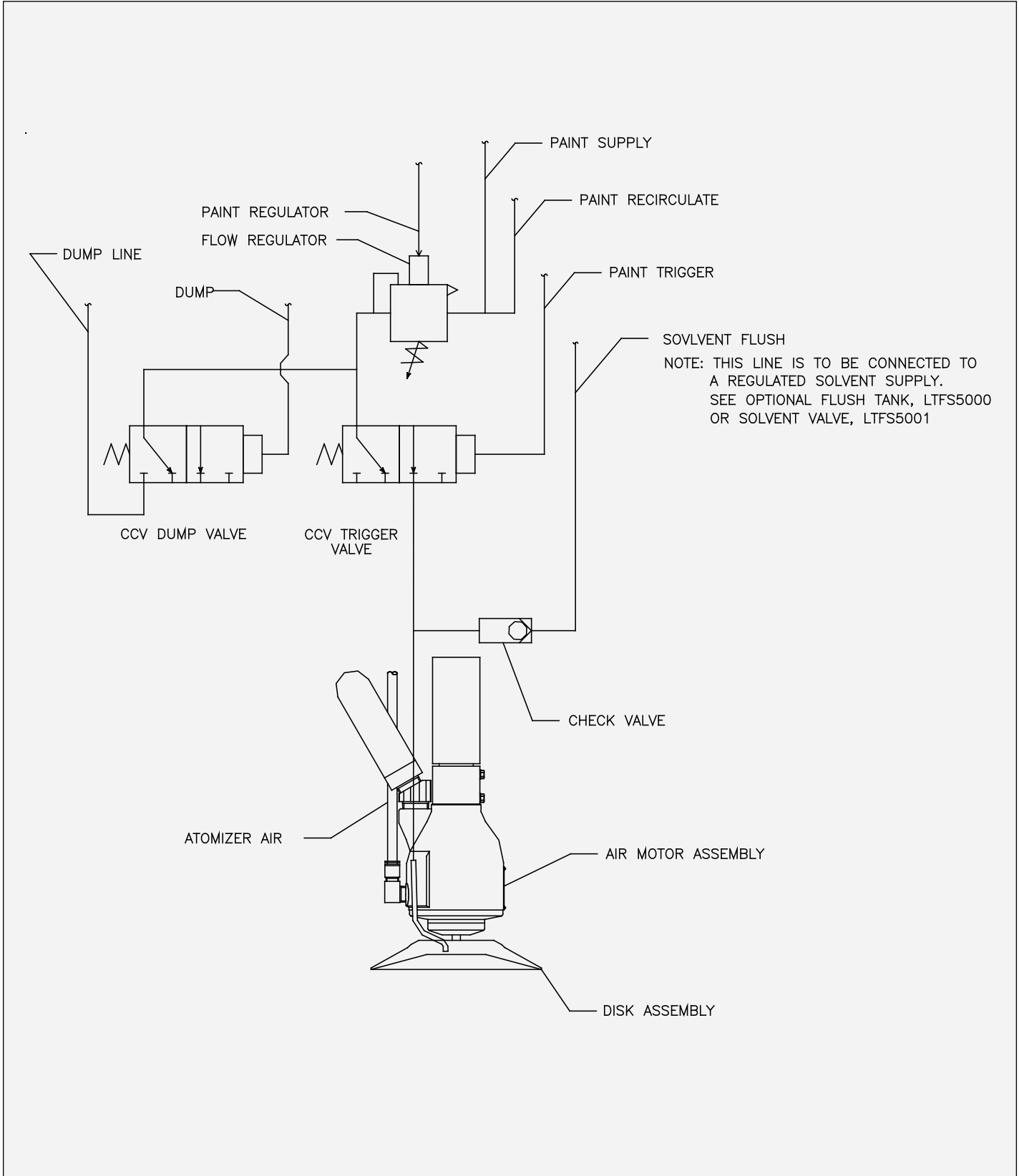

Figure 4: Typical Trigger and Dump Valve Application with DR-1 Regulator Schematic

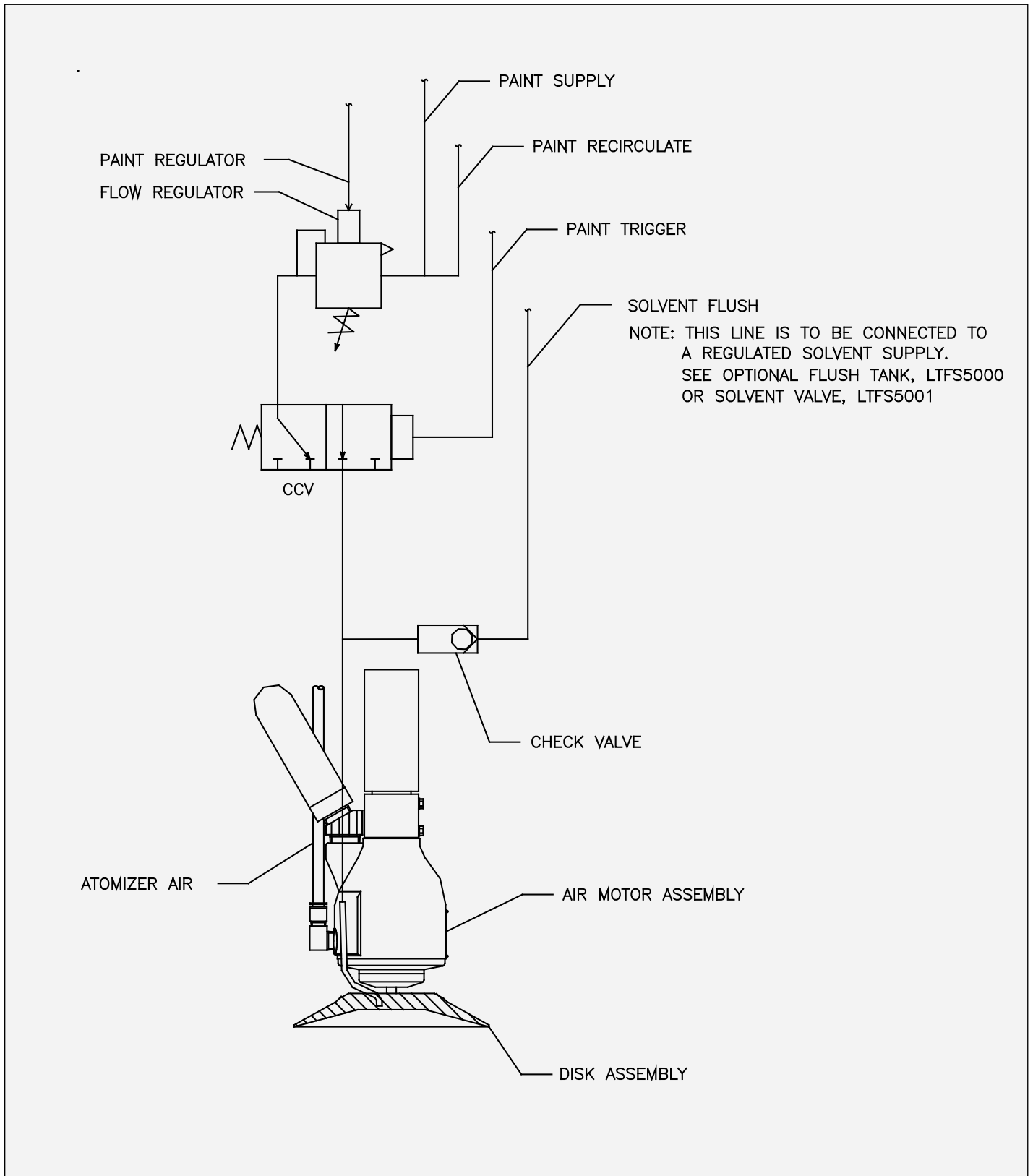

Figure 5: Typical Trigger Valve Only Application with DR-1 Regulator Schematic

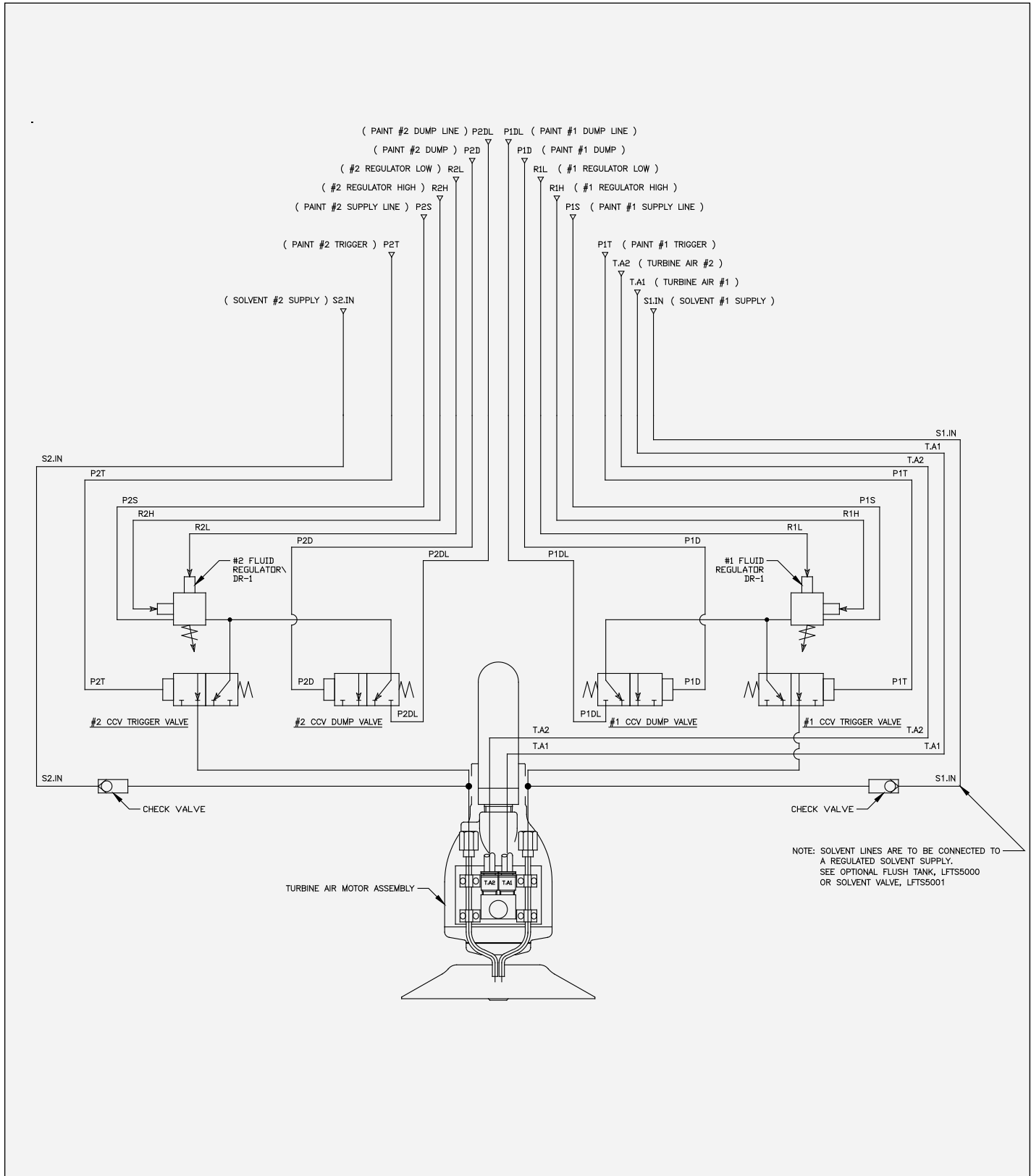

Figure 6: Typical Trigger and Dump Valve Application with 2 DR-1 Fluid Regulators Schematic

PARTS IDENTIFICATION

A11376 TURBODISK ASSEMBLY MODEL IDENTIFICATION

TurboDisk Assemblies are available with the various options as follows:

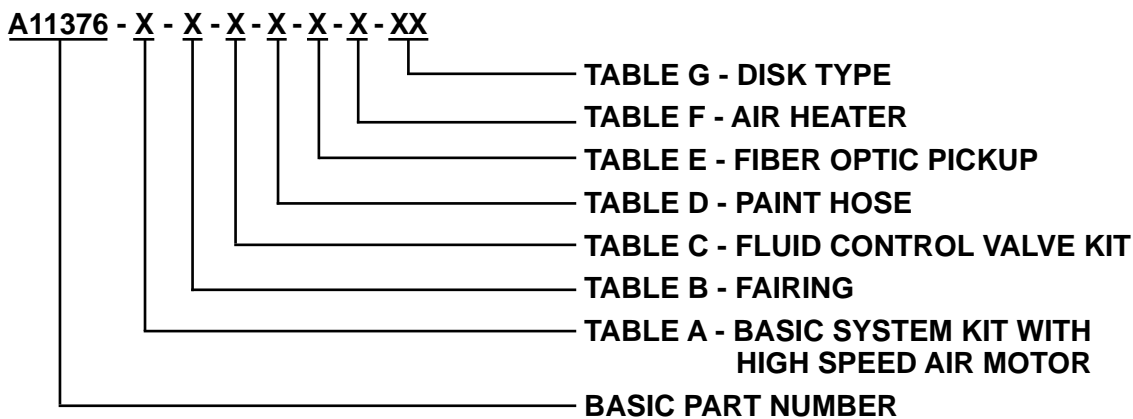

TABLE "A" - BASIC SYSTEMS KIT W/HIGH SPEED AIR MOTOR			
Dash #	Description	Kit Part #	Mounting Nut
1	Downfeed Clockwise - No Tilt	70988-01	19836-01
2	Downfeed Counter-Clockwise - No Tilt	70988-02	19836-02
3	Upfeed Clockwise - No Tilt	70988-03	19836-01
4	Upfeed Counter-Clockwise - No Tilt	70988-04	19836-02
5	Downfeed Clockwise - No Tilt Dual Feed Tube	70988-05	19836-01
6	Downfeed Counter-Clockwise - No Tilt, Dual Feed Tube	70988-06	19836-02
7	Upfeed Clockwise - No Tilt, Dual Feed Tube	70988-07	19836-01
8	Upfeed Counter-Clockwise - No Tilt, Dual Feed Tube	70988-08	19836-02

TABLE "B" - FAIRING		
Dash #	Description	Part #
0	None	--
2	Fairing	70158-02

TABLE "C" - FLUID CONTROL VALVE KIT

Dash #	Description	Kit Part #	DR-1 or High Flow Regulator	
5	No Valves or Fluid Regulator	70975-05	---	
6	3-Way Valve, No Fluid Regulator	70975-06	---	
6	7	Trigger Valve with High Flow Fluid Regulator	70975-07	70171-04
6	8	Trigger & Dump Valve with High Flow Fluid Regulator	70975-08	70171-04
7	A	Trigger Valve with DR-1 Fluid Regulator, 1:2 Ratio	70975-09	74151-01
7	B	Trigger Valve with DR-1 Fluid Regulator, 1:4 Ratio	70975-09	74151-02
7	C	Trigger Valve with DR-1 Fluid Regulator, 1:6 Ratio	70975-09	74151-03
7	D	Trigger Valve with DR-1 Fluid Regulator, 1:8 Ratio	70975-09	74151-04
7	E	Trigger Valve with DR-1 Fluid Regulator, 1:10 Ratio	70975-09	74151-05
7	F	Trigger Valve with DR-1 Fluid Regulator, 1:3 Ratio	70975-09	74151-06
7	G	Trigger Valve with DR-1 Fluid Regulator, 1:1 Ratio	70975-09	74151-11
7	H	Trigger & Dump Valve with DR-1 Fluid Regulator, 1:2 Ratio	70975-10	74151-01
7	J	Trigger & Dump Valve with DR-1 Fluid Regulator, 1:4 Ratio	70975-10	74151-02
7	K	Trigger & Dump Valve with DR-1 Fluid Regulator, 1:6 Ratio	70975-10	74151-03
7	M	Trigger & Dump Valve with DR-1 Fluid Regulator, 1:8 Ratio	70975-10	74151-04
7	N	Trigger & Dump Valve with DR-1 Fluid Regulator, 1:10 Ratio	70975-10	74151-05
7	P	Trigger & Dump Valve with DR-1 Fluid Regulator, 1:3 Ratio	70975-10	74151-06
7	R	Trigger & Dump Valve with DR-1 Fluid Regulator, 1:1 Ratio	70975-10	74151-11
7	S	Trigger & Dump Valve with (2) DR-1 Fluid Regulator, 1:1 Ratio	70975-11	74151-11

TABLE "D" - HOSE FOR PAINT SYSTEM

Dash #	Description	Part #
0	None	--
4	3/8" OD	70977-04
5	1/2" OD	70977-05
6	1/4" OD	70977-06

TABLE "E" - FIBER OPTIC PICKUP

Dash #	Description	Part #
0	None	--
1	Fiber Optic Pickup	SMC-29

TABLE "F" - AIR HEATER

Dash #	Description	Part #
0	None	--
1	Air Heater Manifold Package With High Flow Regulator	78781-00
2	Regulator Assembly - No Heater	78170-00

TABLE "G" - DISK TYPE

Dash #	Description	Part #
00	None	--
01	Disk Assy., Serrated, 6", Aluminum, Not Anodized	20485-62
02	Disk Assy., Serrated, 6", Aluminum, Anodized	20485-65
03	Disk Assy., Serrated, 9", Aluminum, Not Anodized	20485-92
04	Disk Assy., Serrated, 9", Aluminum, Anodized	20485-95
05	Disk Assy., Serrated, 12", Aluminum, Not Anodized	20485-122
06	Disk Assy., Serrated, 12", Aluminum, Anodized	20485-125
07	Uni-Disk Assy., 6", Aluminum, Not Anodized	19830-06
08	Uni-Disk Assy., 8", Aluminum, Not Anodized	19830-08
09	Uni-Disk Assy., 10", Aluminum, Not Anodized	19830-10
10	Uni-Disk Assy., 12", Aluminum, Not Anodized	19830-12
11	Disk Assy., 6" with PTFE insert, DLC Coated	A14248-62
12	Disk Assy., 12" with PTFE insert, DLC Coated	A14248-122

9 (1) Disk Mounting Nut (See "Table A") is included with this assembly. When mounting disk (not included), torque mounting nut to 50-60 lbs•in (5.65-6.78 Nm). (Recommended: 3/8" hex bit socket with square drive torque wrench.)

7 DR-1 Fluid Regulator, 74151-XX can only be used with Fluid Control Valve Kits 70975-09 and 70975-10 as shown in "Table C".

General Application Guideline: Use DR-1 Regulator for paint flow rates from 25 to 1500 cc/min.

6 High Flow Fluid Regulator, 70171-04, can only be used with Fluid Control Valve Kits 70975-07 and 70975-08 as shown in "Table C".

General Application Guideline: Use High Flow Regulator for paint flow rates above 750 cc/min.

70988 BASIC SYSTEMS KIT**70988-01 DOWNFEED, CLOCKWISE**

Part #	Description	Qty
78175-02	Air Motor, High Speed	1
70973-01	Basic Mounting Parts Kit	1
70976-01	Feed Tube Kit	1
19850-00	Disk Puller Assembly	1

70988-02 DOWNFEED, COUNTER-CLOCKWISE

Part #	Description	Qty
78175-12	Air Motor, High Speed	1
70973-01	Basic Mounting Parts Kit	1
70976-01	Feed Tube Kit	1
19850-00	Disk Puller Assembly	1

70988-03 UPFEED, CLOCKWISE

Part #	Description	Qty
78175-02	Air Motor, High Speed	1
70973-01	Basic Mounting Parts Kit	1
70976-02	Feed Tube Kit	1
19850-00	Disk Puller Assembly	1

70988-04 UPFEED, COUNTER-CLOCKWISE

Part #	Description	Qty
78175-12	Air Motor, High Speed	1
70973-01	Basic Mounting Parts Kit	1
70976-03	Feed Tube Kit	1
19850-00	Disk Puller Assembly	1

70988-05 DOWNFEED, CLOCKWISE DUAL FEED TUBE

Part #	Description	Qty
78175-02	Air Motor, High Speed	1
70973-01	Basic Mounting Parts Kit	1
70976-01	Feed Tube Kit	2
19850-00	Disk Puller Assembly	1

Special Order Only.

70988-06 DOWNFEED, COUNTER-CLOCKWISE DUAL FEED TUBE 		
Part #	Description	Qty
78175-12	Air Motor, High Speed	1
70973-01	Basic Mounting Parts Kit	1
70976-01	Feed Tube Kit	2
19850-00	Disk Puller Assembly	1

70988-07 UPFEED, CLOCKWISE DUAL FEED TUBE 		
Part #	Description	Qty
78175-02	Air Motor, High Speed	1
70973-01	Basic Mounting Parts Kit	1
70976-02	Feed Tube Kit	2
19850-00	Disk Puller Assembly	1

70988-08 UPFEED, COUNTER-CLOCKWISE DUAL FEED TUBE 		
Part #	Description	Qty
78175-12	Air Motor, High Speed	1
70973-01	Basic Mounting Parts Kit	1
70976-03	Feed Tube Kit	2
19850-00	Disk Puller Assembly	1

 Special Order Only.

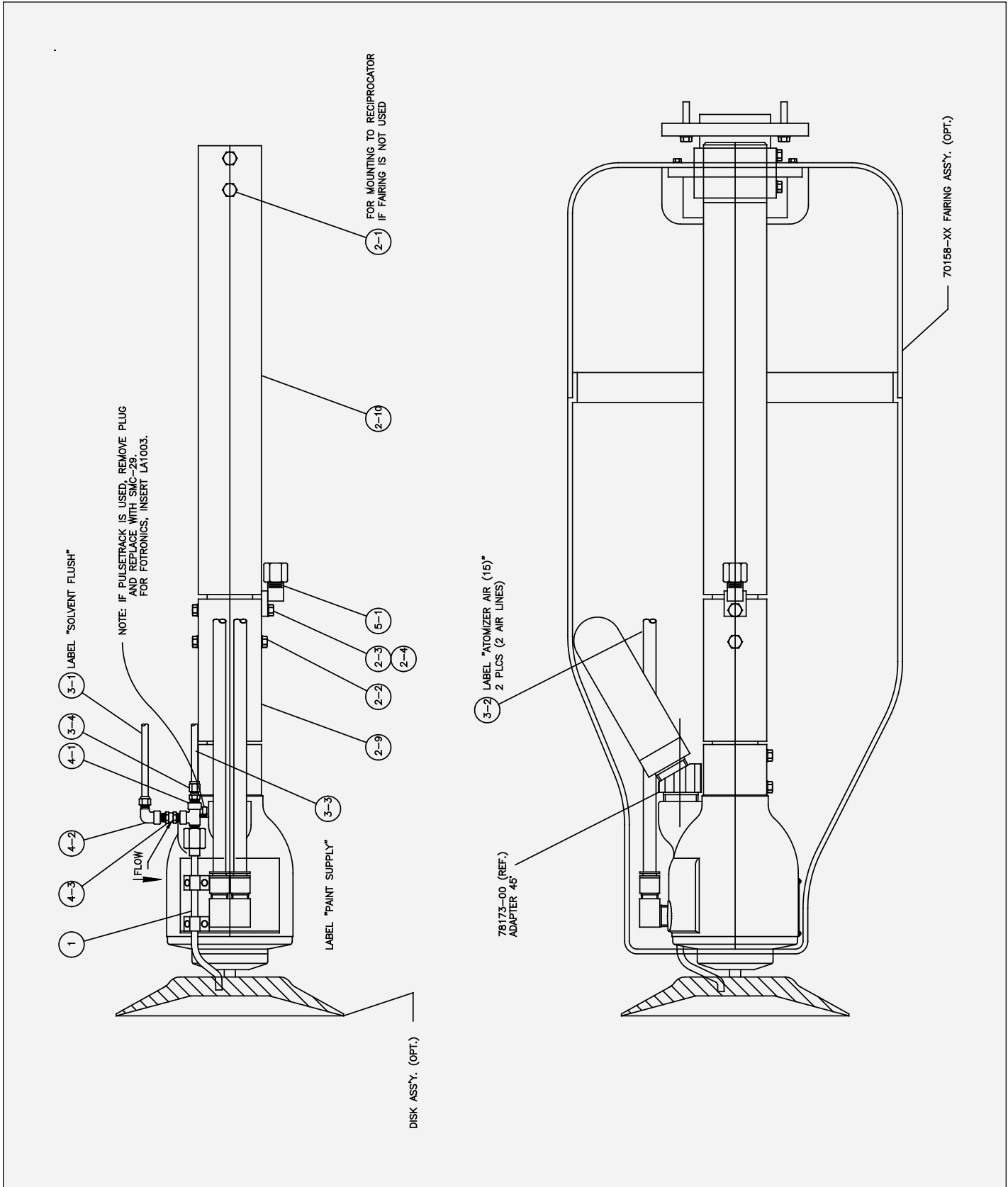

Figure 7: 70990-05 TurboDisk Assembly, No Valves

70990-05 TURBODISK ASSEMBLY, NO VALVES - PARTS LIST (Figure 7)

Item #	Part #	Description	Qty	Notes
1	70976-01	Feed Tube Kit, Downfeed	1	Part of 70988-XX Kit
<i>These parts are supplied with Kit 70973-01 Hardware & Mounting Parts Kit</i>				
2-1	8156-24F	Screw, 5/16-24 X 3/4", Hex Head	2	
2-2	8156-32F	Screw, 5/16-24 X 1", Hex Head	5	
2-3	8156-40F	Screw, 5/16-24 X 1-1/4", Hex Head	1	
2-4	7734-07	L Washer, Spring, 5/16"	6	
2-9	15980-00	Extension Arm, Air Motor	1	
2-10	1613-03	Tube Support, 20-3/8"	1	
2-11	8156-48F	Screw, 5/16-24 X 1-1/2", Hex Head (Not Used)	2	
2-13	27141-081	Hose Wrapping (Not Shown)	25'	Same as TR-SSEM-082
2-14	15946-00	Grounding Hook Assembly (Not Shown)	1	
2-15	10384-01	Tubing, Latex, 3/16" ID X 1/16" Wall (Not Shown)	50'	
5-1	17274-00	High Voltage Connector Assembly	1	
<i>These parts are supplied with Kit 70977-04 (3/8" OD) Low Flow or 70977-05 (1/2" OD) High Flow, Tube & Fitting Kit (Shipped loose as Kit, no assembly)</i>				
3-1	9704-03	Tubing, LD/PE, 1/4" OD X .17" ID	100'	
3-2	7113-13	Tubing, 1/2" OD X .060" Wall, Nylon	50'	
3-3	SSP-5020	Tubing, 3/8" OD X 1/4" ID	100'	Supplied with Kit 70977-04 only
3-3	55994-26	Tubing, 1/2" OD X 3/8" ID	100'	Supplied with Kit 70977-05 only
3-4	41-FTC-1002	Fitting, Connector, 3/8" T X 1/4" NPT	4	Supplied with Kit 70977-04 only
3-4	LSFI0005-01	Connector, Straight, 1/2" OD Tube X 1/4" NPT	4	Supplied with Kit 70977-05 only
3-5	78006-00	Elbow	2	
<i>These parts are supplied with Kit 70975-05, No Valve Kit</i>				
4-1	LSFI0004-01	Street Tee, 1/4" NPT, SS	1	
4-2	LSFI0006-01	Elbow, 1/4" OD Tube X 1/4" NPT Female, SS	1	
4-3	SSV-809	Check Valve, 1/4" NPT, Male	1	
4-4	LSFI0018-01	Ferrule Kit, 1/2" Nylon (Not Shown)	1	

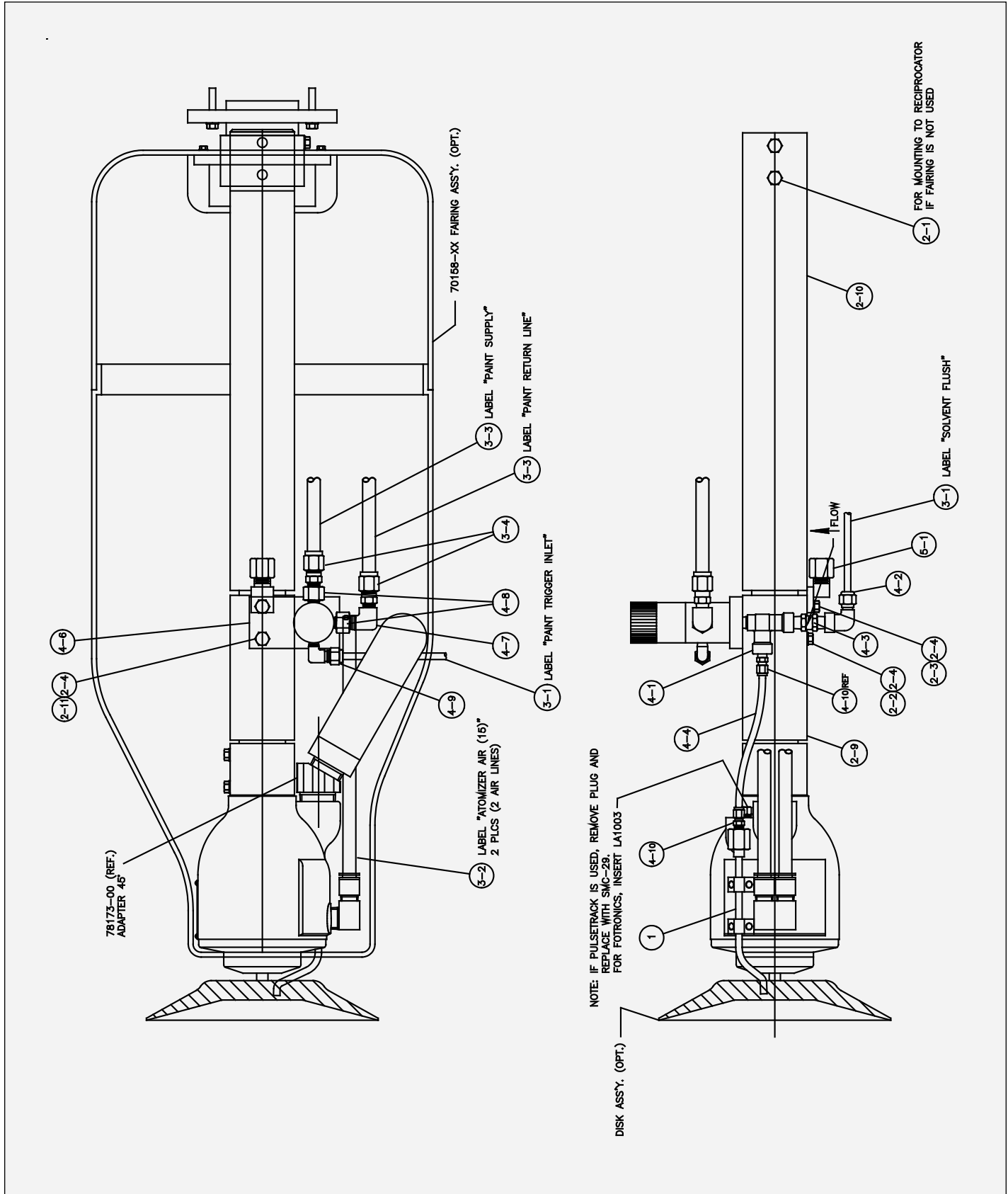





Figure 8: 70990-06 TurboDisk Assembly, 3-Way Valves

70990-06 TURBODISK ASSEMBLY, 3-WAY VALVES - PARTS LIST (Figure 8)

Item #	Part #	Description	Qty	Notes
1	70976-01	Feed Tube Kit, Downfeed	1	Part of 70988-XX Kit
<i>These parts are supplied with Kit 70973-01 Hardware & Mounting Parts Kit</i>				
2-1	8156-24F	Screw, 5/16-24 X 3/4", Hex Head	2	
2-2	8156-32F	Screw, 5/16-24 X 1", Hex Head	5	
2-3	8156-40F	Screw, 5/16-24 X 1-1/4", Hex Head	1	
2-4	7734-07	L Washer, Spring, 5/16"	6	
2-9	15980-00	Extension Arm, Air Motor	1	
2-10	1613-03	Tube Support, 20-3/8"	1	
2-11	8156-48F	Screw, 5/16-24 X 1-1/2", Hex Head (Not Used)	2	
2-13	27141-081	Hose Wrapping (Not Shown)	25'	Same TR-SSEM-082
2-14	15946-00	Grounding Hook Assembly (Not Shown)	1	
2-15	10384-01	Tubing, Latex, 3/16" ID X 1/16" Wall (Not Shown)	50'	
5-1	17274-00	High Voltage Connector Assembly	1	
<i>These parts are supplied with Kit 70977-04 (3/8" OD) Low Flow or 70977-05 (1/2" OD) High Flow, Tube & Fitting Kit (Shipped loose as Kit, no assembly)</i>				
3-1	9704-03	Tubing, LD/PE, 1/4" OD X .17" ID	100'	
3-2	7113-13	Tubing, 1/2" OD X .060" Wall, Nylon	50'	
3-3	SSP-5020	Tubing, 3/8" OD X 1/4" ID	100'	Supplied with Kit 70977-04 only
3-3	55994-26	Tubing, 1/2" OD X 3/8" ID	100'	Supplied with Kit 70977-05 only
3-4	41-FTC-1002	Fitting, Connector, 3/8" T X 1/4" NPT	4	Supplied with Kit 70977-04 only
3-4	LSFI0005-01	Connector, Straight, 1/2" OD Tube X 1/4" NPT	4	Supplied with Kit 70977-05 only
3-5	78006-00	Elbow	2	
<i>These parts are supplied with Kit 70975-06, 3-Way Valve Kit</i>				
4-1	LSFI0004-01	Street Tee, 1/4" NPT, SS	1	
4-2	LSFI0006-01	Elbow, 1/4" OD Tube X 1/4" NPT Female, SS	1	
4-3	SSV-809	Check Valve, 1/4" NPT, SS	1	
4-4	55994-23	Tubing, FEP, .156" ID X .25" OD	5'	
4-6	18283-02	Valve Assembly, 3-Way	1	
4-7	LSFI0009-01	Elbow, Street, 1/4" NPT, SS	1	
4-8	SSP-39	Reducer, 1/8" NPT, Male X 1/4" NPT, Female, SS	2	
4-9	SSP-6427	Elbow, 1/4" OD Tube X 1/8" NPT, Brass	1	
4-10	70590-01	Connector, Male, 1/4" OD Tube X 1/4" NPT, SS	2	
4-11	8156-48F	Screw, 5/16-32 X 1-1/4" Lg., Hex Head	2	
4-12	7734-07	L Washer, 5/16"	2	
4-13	17366-00	Repair Kit, 3-Way Valve (Not Shown)	1	
4-14	LSFI0018-01	Ferrule Kit (Not Shown)	1	
4-14	AU-81-02	Service Literature (Not Shown)	1	

70990-07 TURBODISK ASSEMBLY, TRIGGER VALVES ONLY - PARTS LIST (Figure 9)

Item #	Part #	Description	Qty	Notes
1	70976-01	Feed Tube Kit, Downfeed	1	Part of 70988-XX Kit
These parts are supplied with Kit 70973-01 Hardware & Mounting Parts Kit				
2-1	8156-24F	Screw, 5/16-24 X 3/4", Hex Head	2	
2-2	8156-32F	Screw, 5/16-24 X 1", Hex Head	5	
2-3	8156-40F	Screw, 5/16-24 X 1-1/4", Hex Head	1	
2-4	7734-07	L Washer, Spring, 5/16"	6	
2-9	15980-00	Extension Arm, Air Motor	1	
2-10	1613-03	Tube Support, 20-3/8"	1	
2-11	8156-48F	Screw, 5/16-24 X 1-1/2", Hex Head (Not Used)	2	
2-13	27141-081	Hose Wrapping (Not Shown)	25'	Same TR-SSEM-082
2-14	15946-00	Grounding Hook Assembly (Not Shown)	1	
2-15	10384-01	Tubing, Latex, 3/16" ID X 1/16" Wall (Not Shown)	50'	
5-1	17274-00	High Voltage Connector Assembly	1	
These parts are supplied with Kit 70977-04 (3/8" OD) Low Flow or 70977-05 (1/2" OD) High Flow, Tube & Fitting Kit (Shipped loose as Kit, no assembly)				
3-1	9704-03	Tubing, LD/PE, 1/4" OD X .17" ID	100'	
3-2	7113-13	Tubing, 1/2" OD X .060" Wall, Nylon	50'	
3-3	SSP-5020	Tubing, 3/8" OD X 1/4" ID	100'	Supplied with Kit 70977-04 only
3-3	55994-26	Tubing, 1/2" OD X 3/8" ID	100'	Supplied with Kit 70977-05 only
3-4	41-FTC-1002	Fitting, Connector, 3/8" T X 1/4" NPT	4	Supplied with Kit 70977-04 only
3-4	LSFI0005-01	Connector, Straight, 1/2" OD Tube X 1/4" NPT	4	Supplied with Kit 70977-05 only
3-5	78006-00	Elbow	2	
These parts are supplied with Kit 70975-07 (High Flow) or 70975-09 (Low Flow) Trigger Valve W/Regulator or Regulator Ready				
* Indicates supplied W/70975-07 Only ** Indicates supplied W/70975-09 Only				
4-1	70590-01	Connector, Male, 1/4" OD Tube X 1/4" NPT, SS	1	
4-2	LSFI0038-00	Elbow, SST, 1/4" NPT(F) X 1/8" NPT(M)	1	
4-3	76462-00	Fitting, SST, 1/4" NPT, Male, Branch Tee	1	
4-4	LRPM0105	Bracket	1	
4-5	CCV-12-SS	Valve Adapter	1	
4-6	CCV-403-SS	Trigger Valve Assembly	1	
4-7	SSP-6054	Connector, 1/4" OD Tube X 1/8" NPT, Male, Brass	1	
4-8	55994-23	Tubing, FEP, .250" OD X .156" ID	5'	
4-8	55994-24	Tubing, FEP, .250 OD X .126 ID	5'	
4-9	SSP-1421	Plug, Hex Socket, 1/4" NPT	1	
4-10	7958-56C	Screw, 1/4-20 X 1-3/4" Lg., Hex Head	2	
4-11	7734-06	L Washer, 1/4"	4	

 Use as required to increase fluid pressure at regulator outlet to approx. 5-20 psi
 Pressure Change Across Tubing (PSI) $\approx .601 \times 10^6 \times \text{Flow Rate (in}^3/\text{min)} \times \text{Viscosity (Poise)} \times \text{Fluid Length (in)}$
 $[\text{Tube ID (in)}]^4$

(Continued On Next Page)

70990-07 TURBODISK ASSEMBLY, TRIGGER VALVES ONLY - PARTS LIST (Cont.) (Figure 9)

Item #	Part #	Description	Qty	Notes
<p>These parts are supplied with Kit 70975-07 (High Flow) of 70975-09 (Low Flow) Trigger Valve W/Regulator or Regulator Ready * Indicates supplied W/70975-07 Only ** Indicates supplied W/70975-09 Only</p>				
4-12	78004-00	Bushing, 1/2" NPT Male X 1/4" NPT Female, SS *	2	
4-13	78006-00	Elbow, Street, 1/4" NPT, SS	2	
4-14	SSP-6439	Elbow, Swivel, Male, 1/4" OD X 1/4" NPT, Brass	1	
4-15	LSFI0007-01	Elbow, 1/4" OD Tube X 1/4" NPT Male, SS *	2	
4-16	LSFI0006-01	Elbow, 1/4" OD Tube X 1/4" NPT Female, SS	1	
4-17	SSV-809	Check Valve, 1/4" NPT	1	
4-18	70171-04	Flow Regulator Assembly *	1	
4-18	74151-XX	Flow Regulator, DR-1 (Not Shown) **	1	
4-18	70589-05	Fitting, 1/4" OD Tube, Special (Not Shown) **	1	
4-18	8212-32F	Screw, Regulator Mounting (Not Shown) **	2	
4-18	7787-02	Adapter, 1/4" NPSF to 1/4" NPTF, Carbon Steel **	1	(Not Shown)
4-18	LSFI0004-01	Tee, Street, 1/4" NPT (Not Shown) **	1	
4-19	SSF-8125	Hex Jam Nut	1	
4-20	20810-00	Bracket, Regulator *	1	
4-20	LSMM0025	Bracket, DR-1 (Not Shown) **	1	
4-21	LSFI0018-01	Ferrule Kit (Not Shown)	1	
4-22	AU-81-07	Flow Regulator Service Manual - 70171-04	1	(Not Shown) *
4-22	LN-9223-00	DR-1 Fluid Regulator Service Manual - 74151-XX	1	(Not Shown) **
4-23	KK-4841	Repair Kit, CCV-403-SS (Not Shown)	1	
4-25	CCV-7	Valve Tool (Not Shown)	1	

3 Use as required to increase fluid pressure at regulator outlet to approx. 5-20 psi
 Pressure Change Across Tubing (PSI) $\approx \frac{.601 \times 10^6 \times \text{Flow Rate (in}^3/\text{min)} \times \text{Viscosity (Poise)} \times \text{Fluid Length (in)}}{[\text{Tube ID (in)}]^4}$

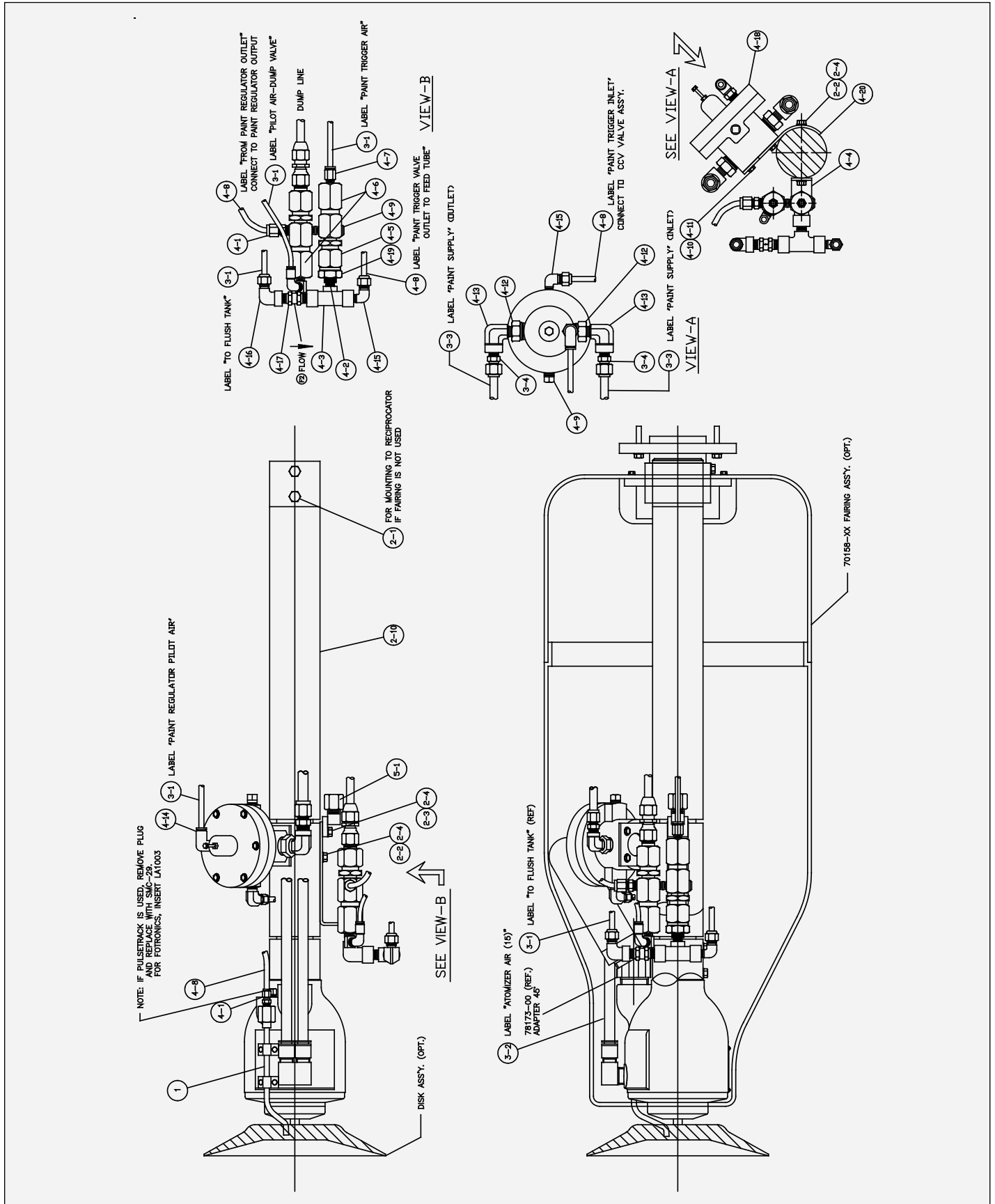



Figure 10: 70990-08 TurboDisk Assembly, Trigger and Dump Valve

70990-08 TURBODISK ASSEMBLY, TRIGGER AND DUMP VALVE - PARTS LIST (Figure 10)

Item #	Part #	Description	Qty	Notes
1	70976-01	Feed Tube Kit, Downfeed	1	Part of 70988-XX Kit
These parts are supplied with Kit 70973-01 Hardware & Mounting Parts Kit				
2-1	8156-24F	Screw, 5/16-24 X 3/4", Hex Head	2	
2-2	8156-32F	Screw, 5/16-24 X 1", Hex Head	5	
2-3	8156-40F	Screw, 5/16-24 X 1-1/4", Hex Head	1	
2-4	7734-07	L Washer, Spring, 5/16"	6	
2-9	15980-00	Extension Arm, Air Motor	1	
2-10	1613-03	Tube Support, 20-3/8"	1	
2-11	8156-48F	Screw, 5/16-24 X 1-1/2", Hex Head (Not Used)	2	
2-13	27141-081	Hose Wrapping (Not Shown)	25'	Same as TR-SSEM-082
2-14	15946-00	Grounding Hook Assembly (Not Shown)	1	
2-15	10384-01	Tubing, Latex, 3/16" ID X 1/16" Wall (Not Shown)	50'	
5-1	17274-00	High Voltage Connector Assembly	1	
These parts are supplied with Kit 70977-04 (3/8" OD) Low Flow or 70977-05 (1/2" OD) High Flow, Tube & Fitting Kit (Shipped loose as Kit, no assembly)				
3-1	9704-03	Tubing, LD/PE, 1/4" OD X .17" ID	100'	
3-2	7113-13	Tubing, 1/2" OD X .060" Wall, Nylon	50'	
3-3	SSP-5020	Tubing, 3/8" OD X 1/4" ID	100'	Supplied with Kit 70977-04 only
3-3	55994-26	Tubing, 1/2" OD X 3/8" ID	100'	Supplied with Kit 70977-05 only
3-4	41-FTC-1002	Fitting, Connector, 3/8" T X 1/4" NPT	4	Supplied with Kit 70977-04 only
3-4	LSFI0005-01	Connector, Straight, 1/2" OD Tube X 1/4" NPT	4	Supplied with Kit 70977-05 only
3-5	78006-00	Elbow	2	
These parts are supplied with Kit 70975-08 (High Flow) or 70975-10 (Low Flow) Trigger and Dump Valve W/Regulator Ready * Indicates supplied w/70975-08 only. ** Indicates supplied w/70975-10 only.				
4-1	70590-01	Connector, Male, 1/4" OD Tube X 1/4" NPT, SS	1	
4-2	LSFI0038-00	Elbow, SST, 1/4" NPT(F) X 1/8" NPT(M)	1	
4-3	76462-00	Fitting, SST, 1/4" NPT, Male, Branch Tee	1	
4-4	LRPM0105	Bracket	1	
4-5	CCV-12-SS	Valve Adapter	1	
4-6	LDSK4000	2-Valve Assembly, Trigger and Dump	1	
4-7	SSP-6054	Connector, 1/4" OD Tube X 1/8" NPT, Male, Brass	1	
4-8	55994-23	Tubing, FEP, .250" OD X .156" ID	5'	
4-8	55994-24	Tubing, FEP, .250 OD X .126 ID	5'	
4-9	SSP-1421	Plug, Hex Socket, 1/4" NPT	1	
4-10	7958-56C	Screw, 1/4-20 X 1-3/4" Lg., Hex Head	2	
4-11	7734-06	L Washer, 1/4"	4	

(Continued On Next Page)

70990-08 TURBODISK ASSEMBLY, TRIGGER AND DUMP VALVE - PARTS LIST (Cont.) (Figure 10)

Item #	Part #	Description	Qty	Notes
<p>These parts are supplied with Kit 70975-08 (High Flow) or 70975-10 (Low Flow) Trigger and Dump Valve W/Regulator Ready * Indicates supplied w/70975-08 only. ** Indicates supplied w/70975-10 only.</p>				
4-12	78004-00	Bushing, 1/2" NPT Male X 1/4" NPT Female, SS *	2	
4-13	78006-00	Elbow, Street, 1/4" NPT, SS	2	
4-14	SSP-6439	Elbow, Swivel, Male, 1/4" OD X 1/4" NPT, Brass *	1	
4-15	LSFI0007-01	Elbow, 1/4" OD Tube X 1/4" NPT Male, SS	2	
4-16	LSFI0006-01	Elbow, 1/4" OD Tube X 1/4" NPT Female, SS	1	
4-17	SSV-809	Check Valve, 1/4" NPT	1	
4-18	70171-04	Flow Regulator Assembly (Reference) *	1	
4-18	74151-XX	Flow Regulator, DR-1 (Not Shown) **	1	
4-18	70589-05	Fitting, 1/4" OD Tube, Special (Not shown) **	1	
4-18	8212-32F	Screw, Regulator Mounting (Not Shown) **	2	
4-18	7787-02	Adapter, 1/4" NPSF to 1/4" NPTF, Carbon Steel (Not Shown)**	1	
4-18	LSFI0004-01	Tee, Street, 1/4" NPT (Not Shown) **	1	
4-19	SSF-8125	Hex Jam Nut	1	
4-20	20810-00	Bracket, Regulator *	1	
4-20	LSMM0025	Bracket, DR-1 **	1	
4-21	LSFI0018-01	Ferrule Kit (Not Shown)	1	
4-22	AU-81-07	Flow Regulator Service Manual, 70174-04 (Not Shown)*	1	
4-22	LN-9223-00	DR-1 Fluid Regulator Service Manual (74151-XX)	1	Not Shown
4-23	KK-4841	Repair Kit, CCV-403-SS (Not Shown)	1	
4-25	CCV-7	Valve Tool (Not Shown)	1	

3 Use as required to increase fluid pressure at regulator outlet to approx. 5-20 psi
 Pressure Change Across Tubing (PSI) $\approx \frac{.601 \times 10^6 \times \text{Flow Rate (in}^3/\text{min)} \times \text{Viscosity (Poise)} \times \text{Fluid Length (in)}}{[\text{Tube ID (in)}]^4}$

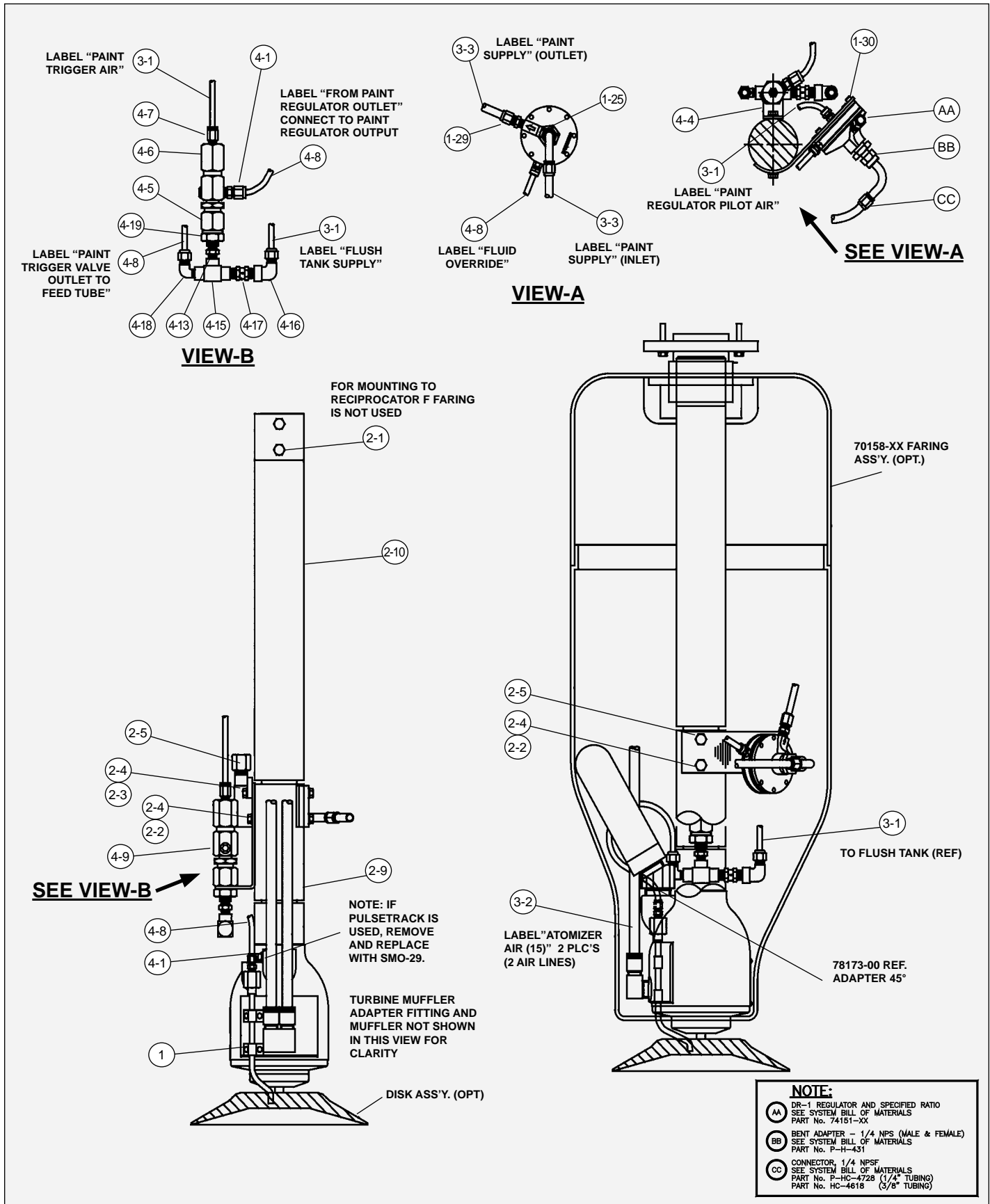



Figure 11: 70990-09 TurboDisk Assembly, Trigger Valve Only W/DR-1 Regulator

70990-09 TURBODISK ASSEMBLY, TRIGGER VALVE ONLY W/DR-1 REGULATOR - PARTS LIST (Figure 11)

Item #	Part #	Description	Qty	Notes
1	70976-01	Feed Tube Kit, Downfeed	1	Part of 70988-XX Kit
These parts are supplied with Kit 70973-01 Hardware & Mounting Parts Kit				
2-1	8156-24F	Screw, 5/16-24 X 3/4", Hex Head	2	
2-2	8156-32F	Screw, 5/16-24 X 1", Hex Head	5	
2-3	8156-40F	Screw, 5/16-24 X 1-1/4", Hex Head	1	
2-4	7734-07	L Washer, Spring, 5/16"	6	
2-5	17274-00	High Voltage Connector Assembly	1	
2-9	15980-00	Extension Arm, Air Motor	1	
2-10	1613-03	Tube Support, 20-3/8"	1	
2-11	8156-48F	Screw, 5/16-24 X 1-1/2", Hex Head (Not Used)	2	
2-12	3923-02	Spiral Wrap, 1/2" (Not Shown)	25'	
2-13	27141-081	Hose Wrapping (Not Shown)	25'	Same as TR-SSEM-082
2-14	15946-00	Grounding Hook Assembly (Not Shown)	1	
2-15	10384-01	Tubing, Latex, 3/16" ID X 1/16" Wall (Not Shown)	50'	
These parts are supplied with Kit 70977-04 (3/8" OD) Low Flow or 70977-05 (1/2" OD) High Flow, Tube & Fitting Kit (Shipped loose as Kit, no assembly)				
3-1	9704-03	Tubing, LD/PE, 1/4" OD X .17" ID	100'	
3-2	7113-13	Tubing, 1/2" OD X .060" Wall, Nylon	50'	
3-3	SSP-5020	Tubing, 3/8" OD X 1/4" ID	100'	Supplied with Kit 70977-04 only
3-3	55994-26	Tubing, 1/2" OD X 3/8" ID	100'	Supplied with Kit 70977-05 only
3-4	78006-00	Elbow, 3/8" OD Tube X 1/4" NPT	2	Supplied with Kit 70977-04 only
3-4	LSFI0005-01	Connector, Straight, 1/2" OD Tube X 1/4" NPT	4	Supplied with Kit 70977-05 only
3-5	41-FTC-1002	Connector, Straight, 3/8" OD Tube X 1/4" NPT	4	
These parts are supplied with Kit 70975-09 Trigger Valve Kit				
4-1	70590-01	Connector, Male, 1/4" OD Tube X 1/4" NPT, SS	1	
4-4	LRPM0105	Bracket	1	
4-5	CCV-12-SS	Valve Adapter	1	
4-6	CCV-403-SS	Trigger Valve Assembly	1	
4-7	SSP-6054	Connector, 1/4" OD Tube X 1/8" NPT, Male, Brass	1	
4-8	55994-28	Tubing, FEP, .188" ID X .250" OD	5'	
4-9	SSP-1421	Plug, Hex Socket, 1/4" NPT	1	
4-13	LSFI0038-00	Elbow, Street, Reducing, 1/8" NPTM X 1/4" NPTF, SS	2	
4-14	SSP-6439	Elbow, Swivel, Male, 1/4" OD X 1/4" NPT, Brass	1	
4-15	76462-00	Service Tee, NI, 1/4"	1	
4-16	LSFI0006-01	Elbow, 1/4" OD Tube X 1/4" NPT, Female, SS	1	
4-17	SSV-809	Check Valve, 1/4" NPT	1	
4-18	LSFI0007-01	Elbow, Male, SS	1	

(Continued On Next Page)

70990-09 TURBODISK ASSEMBLY, TRIGGER VALVE ONLY W/DR-1 REGULATOR - PARTS LIST (Figure 11) (Cont.)

Item #	Part #	Description	Qty	Notes
These parts are supplied with Kit 70975-09 Trigger Valve Kit				
4-19	SSF-8125	Hex Jam Nut	1	
4-20	LSMM0025-00	Bracket, Regulator	1	
4-21	LSFI0018-01	Ferrule, Kit (Not Shown)	1	
4-22	LN-9223-00	DR-1 Fluid Regulator Service Manual (Not Shown)	1	
4-23	KK-4841	Repair Kit, CCV-403-SS (Not Shown)	1	
4-25	CCV-7	Valve Tool (Not Shown)	1	
4-26	55994-23	Tubing, .156" ID X .253" OD	5'	
4-27	55994-24	Tubing, 1/4" OD X 1/8" ID	5'	
4-28	7787-02	Adapter, 1/4" NPSF to NPTF, Carbon Steel	1	
4-29	70589-05	Fitting, Paint, .250" Dia.	1	
4-30	8212-32F	Screw, Cap, Hex Socket, #10-32	2	

 Use as required to increase fluid pressure at regulator outlet to approx. 5-20 psi
 Pressure Change Across Tubing (PSI) $\approx \frac{.601 \times 10^6 \times \text{Flow Rate (in}^3/\text{min)} \times \text{Viscosity (Poise)} \times \text{Fluid Length (in)}}{[\text{Tube ID (in)}]^4}$

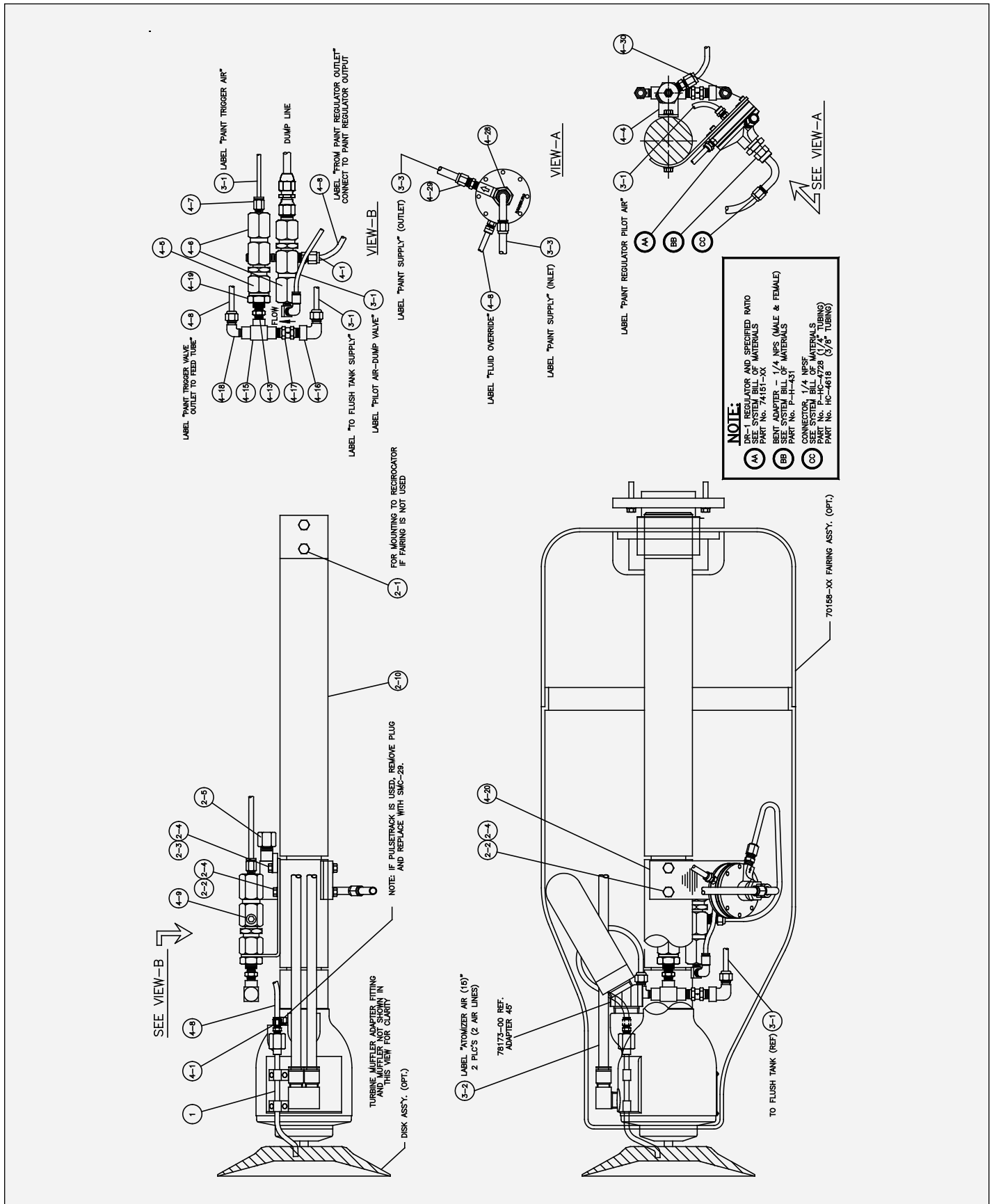



Figure 12: 70990-10 TurboDisk Assembly, Trigger and Dump Valve with DR-1 Regulator

70990-10 TURBODISK ASSEMBLY, TRIGGER AND DUMP VALVE W/DR-1 REGULATOR - PARTS LIST (Figure 12)

Item #	Part #	Description	Qty	Notes
1	70976-01	Feed Tube Kit, Downfeed	1	Part of 70988-XX Kit
These parts are supplied with Kit 70973-01 Hardware & Mounting Parts Kit				
2-1	8156-24F	Screw, 5/16-24 X 3/4", Hex Head	2	
2-2	8156-32F	Screw, 5/16-24 X 1", Hex Head	5	
2-3	8156-40F	Screw, 5/16-24 X 1-1/4", Hex Head	1	
2-4	7734-07	L Washer, Spring, 5/16"	6	
2-5	17274-00	High Voltage Connector Assembly	1	
2-9	15980-00	Extension Arm, Air Motor	1	
2-10	1613-03	Tube Support, 20-3/8	1	
2-11	8156-48F	Screw, 5/16-24 X 1-1/2", Hex Head (Not Used)	2	
2-13	27141-081	Hose Wrapping (Not Shown)	25'	Same as TR-SSEM-082
2-14	15946-00	Grounding Hook Assembly (Not Shown)	1	
2-15	10384-01	Tubing, Latex, 3/16" ID X 1/16" Wall (Not Shown)	50'	
These parts are supplied with Kit 70977-04 (3/8" OD) Low Flow or 70977-05 (1/2" OD) High Flow, Tube & Fitting Kit (Shipped loose as Kit, no assembly)				
3-1	9704-03	Tubing, LD/PE, 1/4" OD X .17" ID	100'	
3-2	7113-13	Tubing, 1/2" OD X .060" Wall, Nylon	50'	
3-3	SSP-5020	Tubing, 3/8" OD X 1/4" ID	100'	Supplied with Kit 70977-04 only
3-3	55994-26	Tubing, 1/2" OD X 3/8" ID	100'	Supplied with Kit 70977-05 only
3-4	78006-00	Elbow, 3/8" OD Tube X 1/4" NPT	2	Supplied with Kit 70977-04 only
3-4	LSFI0005-01	Connector, Straight, 1/2" OD Tube X 1/4" NPT	4	Supplied with Kit 70977-05 only
3-5	41-FTC-1002	Connector, Straight, 3/8" OD Tube X 1/4" NPT	4	
These parts are supplied with Kit 70975-10 Trigger Valve Kit				
4-1	70590-01	Connector, Male, 1/4" OD Tube X 1/4" NPT, SS	1	
4-4	LRPM0105	Bracket	1	
4-5	CCV-12-SS	Valve Adapter	1	
4-6	LDSK4000	2-Valve Assembly, Trigger and Dump	1	
4-7	SSP-6054	Connector, 1/4" OD Tube X 1/8" NPT, Male, Brass	1	
4-8	55994-23	Tubing, FEP, .188" ID X .250" OD	5'	
4-9	SSP-1421	Plug, Hex Socket, 1/4" NPT	1	
4-13	LSFI0038-00	Elbow, Street, Reducing, 1/8" NPTM X 1/4" NPTF, SS	2	
4-15	76462-00	Service Tee, NI, 1/4"	1	
4-16	LSFI0006-01	Elbow, 1/4" OD Tube X 1/4" NPT, Female, SS	1	
4-17	SSV-809	Check Valve, 1/4" NPT	1	
4-18	LSFI0007-01	Elbow, Male, SS	1	
4-19	SSF-8125	Hex Jam Nut	1	
4-20	LSMM0025-00	Bracket, Regulator	1	

(Continued On Next Page)

70990-10 TURBODISK ASSEMBLY, TRIGGER AND DUMP VALVE W/DR-1 REGULATOR - PARTS LIST (Figure 12) (Cont.)

Item #	Part #	Description	Qty	Notes
<i>These parts are supplied with Kit 70975-10 Trigger Valve Kit</i>				
4-21	LSFI0018-01	Ferrule Kit (Not Shown)	1	
4-22	LN-9223-00	DR-1 Fluid Regulator Service Manual (Not Shown)	1	
4-23	KK-4841	Repair Kit, CCV-403-SS (Not Shown)	1	
4-25	CCV-7	Valve Tool (Not Shown)	1	
4-26	55994-23	Tubing, .156" ID X .253" OD	5'	
4-27	55994-24	Tubing, 1/4" OD X 1/8" ID	5'	
4-28	7787-02	Adapter, 1/4" NPSF to NPTF, Carbon Steel	1	
4-29	70589-05	Fitting, Paint, .250" Dia.	1	
4-30	8212-32F	Screw, Cap, Hex Socket, #10-32	2	

 Use as required to increase fluid pressure at regulator outlet to approx. 5-20 psi

$$\text{Pressure Change Across Tubing (PSI)} \approx \frac{.601 \times 10^6 \times \text{Flow Rate (in}^3/\text{min)} \times \text{Viscosity (Poise)} \times \text{Fluid Length (in)}}{[\text{Tube ID (in)}]^4}$$

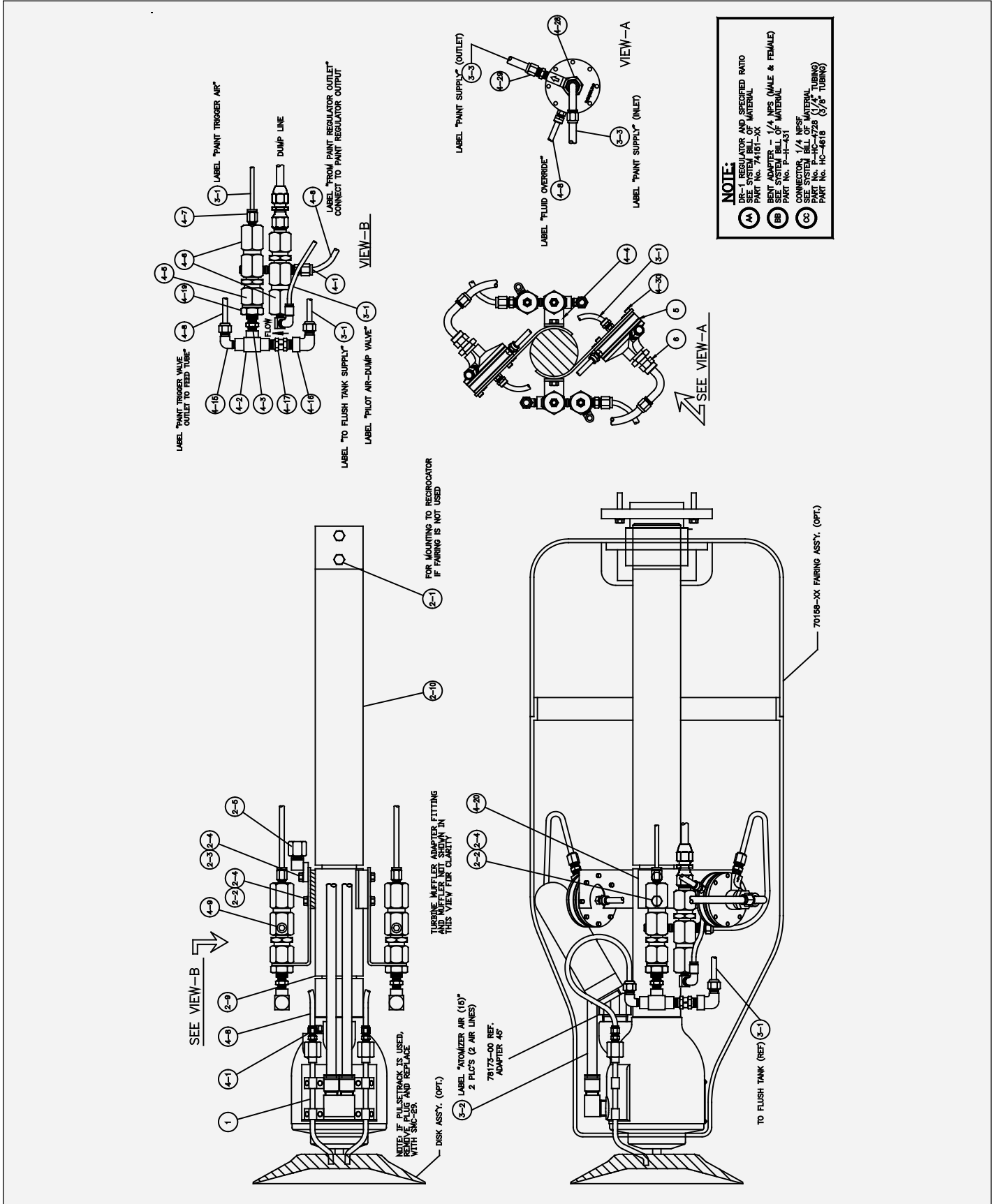

Figure 13: 70990-11 TurboDisk Assembly, Dual DR-1 Regulators

70990-11 TURBODISK ASSEMBLY, DUAL DR-1 REGULATORS - PARTS LIST (Figure 13)

Item #	Part #	Description	Qty	Notes
1	70976-01	Feed Tube Kit, Downfeed	1	Part of 70988-XX Kit
These parts are supplied with Kit 70973-01 Hardware & Mounting Parts Kit				
2-1	8156-24F	Screw, 5/16-24 X 3/4", Hex Head	2	
2-2	8156-32F	Screw, 5/16-24 X 1", Hex Head	5	
2-3	8156-40F	Screw, 5/16-24 X 1-1/4", Hex Head	1	
2-4	7734-07	L Washer, Spring, 5/16"	6	
2-5	17274-00	High Voltage Connector Assembly	1	
2-9	15980-00	Extension Arm, Air Motor	1	
2-10	1613-03	Tube Support, 20-3/8"	1	
2-11	8156-48F	Screw, 5/16-24 X 1-1/2", Hex Head (Not Used)	2	
2-13	27141-081	Hose Wrapping (Not Shown)	25'	Same as TR-SSEM-082
2-14	15946-00	Grounding Hook Assembly (Not Shown)	1	
2-15	10384-01	Tubing, Latex, 3/16" ID X 1/16" Wall (Not Shown)	50'	
These parts are supplied with Kit 70977-04 (3/8" OD) Low Flow or 70977-05 (1/2" OD) High Flow, Tube & Fitting Kit (Shipped loose as Kit, no assembly)				
3-1	9704-03	Tubing, LD/PE, 1/4" OD X .17" ID	100'	
3-2	7113-13	Tubing, 1/2" OD X .060" Wall, Nylon	50'	
3-3	SSP-5020	Tubing, 3/8" OD X 1/4" ID	100'	Supplied with Kit 70977-04 only
3-3	55994-26	Tubing, 1/2" OD X 3/8" ID	100'	Supplied with Kit 70977-05 only
3-4	78006-00	Elbow, 3/8" OD Tube X 1/4" NPT	2	Supplied with Kit 70977-04 only
3-4	LSFI0005-01	Connector, Straight, 1/2" OD Tube X 1/4" NPT	4	Supplied with Kit 70977-05 only
3-5	41-FTC-1002	Connector, Straight, 3/8" OD Tube X 1/4" NPT	4	
These parts are supplied with Kit 70975-11 Trigger Valve Kit				
4-1	70590-01	Connector, Male, 1/4" OD Tube X 1/4" NPT, SS	2	
4-2	76462-00	Tee, 1/4" NPT (X2) X 1/4" NPTM, SS	2	
4-3	LSFI0038-00	Elbow, 1/4" NPTF X 1/8" NPTM, SS	2	
4-4	LRPM0105	Bracket	2	
4-5	CCV-12-SS	Valve Adapter	2	
4-6	LDSK4000	2-Valve Assembly, Trigger and Dump	2	
4-7	SSP-6054	Connector, 1/4" OD Tube X 1/8" NPT, Male, Brass	2	
4-8	55994-28	Tubing, FEP, .188" ID X .250" OD	5'	
4-9	SSP-1421	Plug, Hex Socket, 1/4" NPT	2	
4-15	LSFI0007-01	Elbow, Male, SS	2	
4-16	LSFI0006-01	Elbow, 1/4" OD Tube X 1/4" NPT, Female, SS	2	
4-17	SSV-809	Check Valve, 1/4" NPT	2	
4-19	SSF-8125	Hex Jam Nut	2	
4-20	LSMM0025-00	Bracket, Regulator	2	

(Continued On Next Page)

70990-07 TURBODISK ASSEMBLY, TRIGGER VALVES ONLY - PARTS LIST (Cont.) (Figure 8)

Item #	Part #	Description	Qty	Notes
These parts are supplied with Kit 70975-11 Trigger Valve Kit				
4-21	LSFI0018-01	Ferrule Kit (Not Shown)	2	
4-22	LN-9223-00	DR-1 Fluid Regulator Service Manual (Not Shown)	1	
4-23	KK-4841	Repair Kit, CCV-403-SS (Not Shown)	1	
4-25	CCV-7	Valve Tool (Not Shown)	1	
4-26	55994-23	Tubing, .156" ID X .253" OD	10'	
4-27	55994-24	Tubing, 1/4" OD X 1/8" ID	10'	3
4-28	7787-02	Adapter, 1/4" NPSF to NPTF, Carbon Steel	2	3
4-29	70589-05	Fitting, Paint, .250" Dia.	2	
4-30	8212-32F	Screw, Cap, Hex Socket, #10-32	4	

3 Use as required to increase fluid pressure at regulator outlet to approx. 5-20 psi
 Pressure Change Across Tubing (PSI) $\approx .601 \times 10^6 \times \text{Flow Rate (mi/min)} \times \text{Viscosity (Poise)} \times \text{Fluid Length (in)}$
 $[\text{Tube ID (in)}]^4$

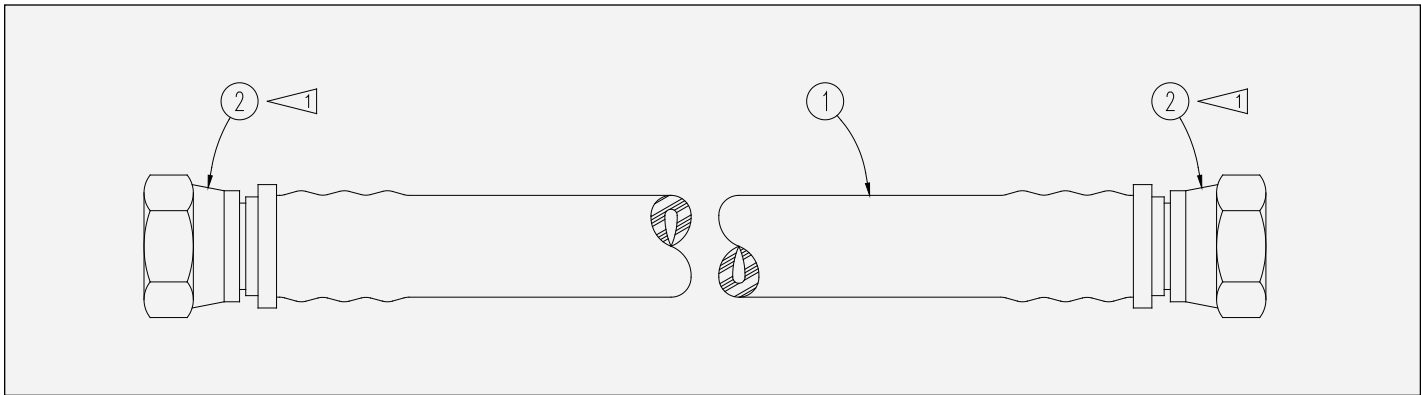

Figure 15: 78166-00 Compressed Air Hose Assembly

78166-00 COMPRESSED AIR HOSE ASSEMBLY - PARTS LIST (Figure 15)

Item #	Part #	Description	Qty
1	78164-00	Hose, 3/4" ID, Push-Lok Air	5'
2	78165-00	Fitting, Female SAE 45° Swivel X 3/4" ID Hose	2

1 Lubricate the fitting and/or hose ID with soapy water only. DO NOT use heavy oil or grease.

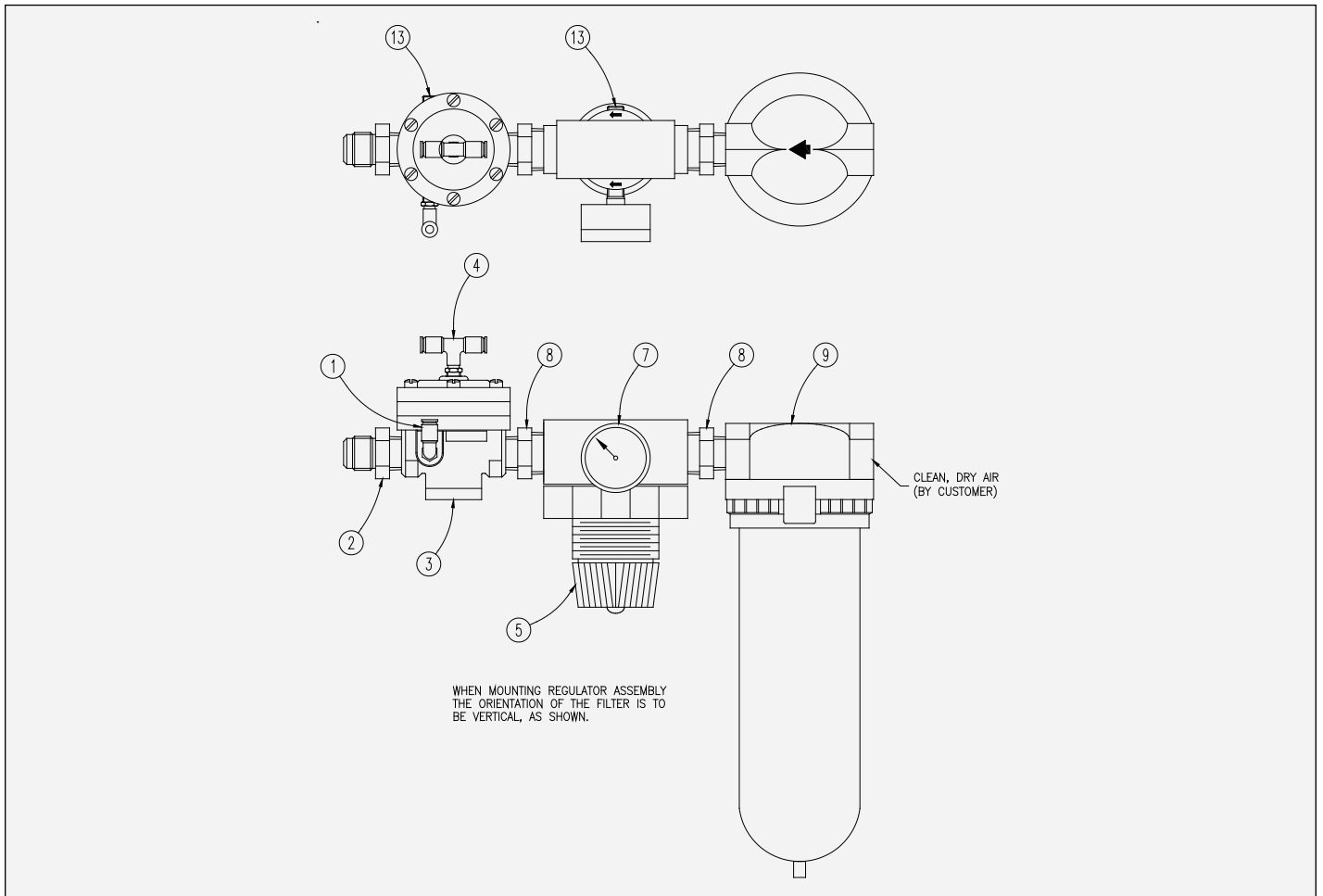

Figure 14: 78170-00 Drive Air Regulator Assembly

78170-00 DRIVE AIR REGULATOR ASSEMBLY - PARTS LIST (Figure 14)			
Item #	Part #	Description	Qty
1	SSP-6439	Elbow, 1/4" OD Tube X 1/4" NPT, Male Swivel	1
2	A11596-00	Fitting, 3/4" NPT X SAE 45°, Male Connector	1
3	A11595-00	Regulator, 3/4" NPT Ported, Air Piloted	1
4	SSP-6819	Tube Fitting	1
5	LS0147	Regulator, 1" Ported, Manual Adjust Air	1
6	--	--	--
7	GA-316	Gauge, 0-160 PSIG, 1/4" NPT, Air	1
8	41-FP-1021	Nipple, 1" NPT X 3/4" NPT, Hex Reducing	2
9	HAF-503	Air Filter, 3/4" NPT	1
10	--	--	--
11	--	--	--
12	--	--	--
13	11021-23	Plug, 1/4" NPT Pipe	Ref.
14	--	--	--

Apply 7969-10 Thread Sealer to all pipe threads prior to assembly.

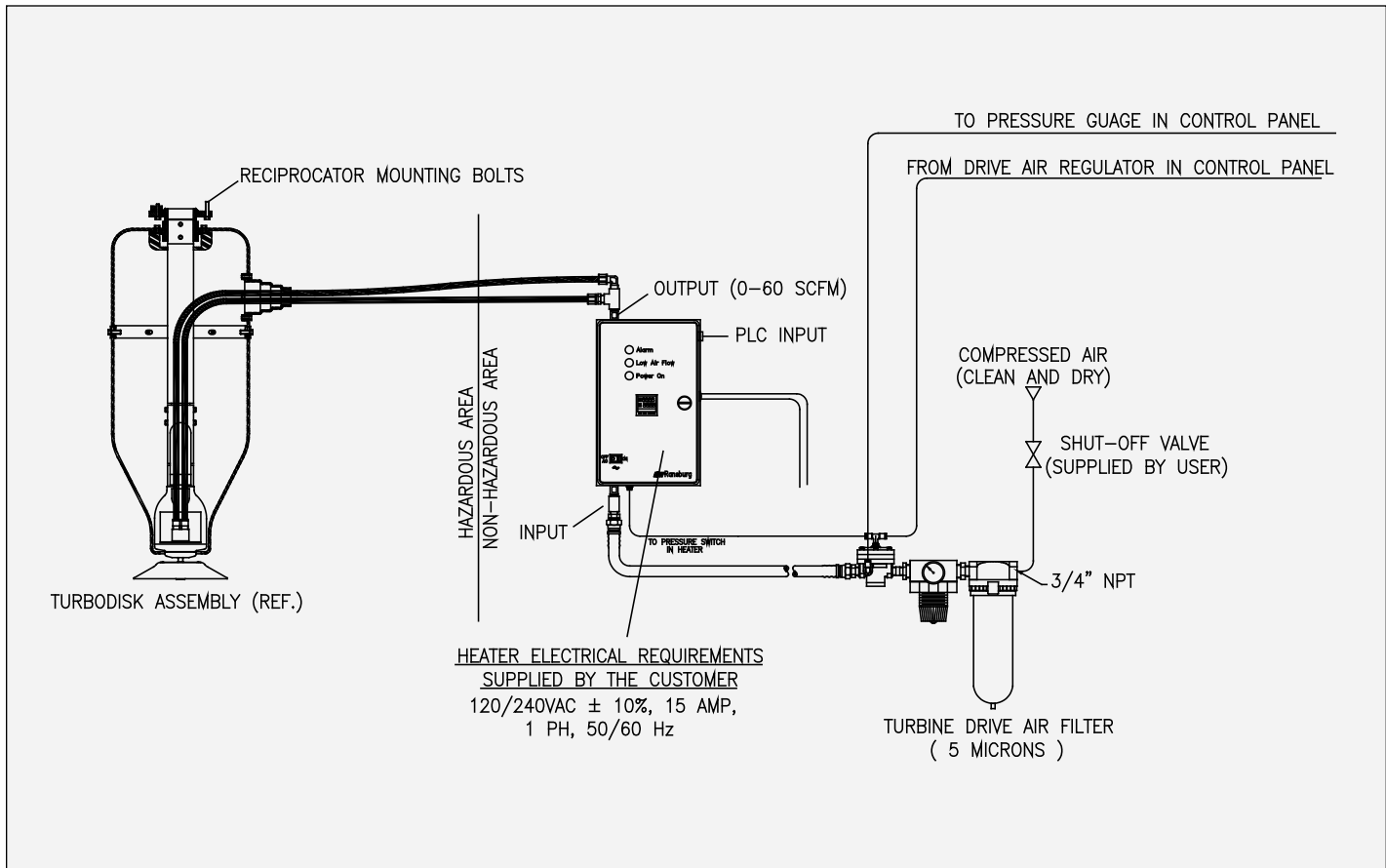



Figure 16: 78781-00 Air Heater and Regulator Assembly

78781-00 AIR HEATER AND REGULATOR ASSEMBLY - PARTS LIST (Figure 16)

Item #	Part #	Description	Qty
1	78170-00	Regulator Assembly, TurboDisk Drive Air	1
2	78166-00	Hose Assembly, Compressed Air	1
3	A11065-05	Air Heater Assembly	1
4	78176-01	Tubing, 1/2" OD X .375" ID, Green Nylon	200 ft.

WARNING

►  The air heater assembly must be located outside of any hazardous areas as defined by the NFPA-33.

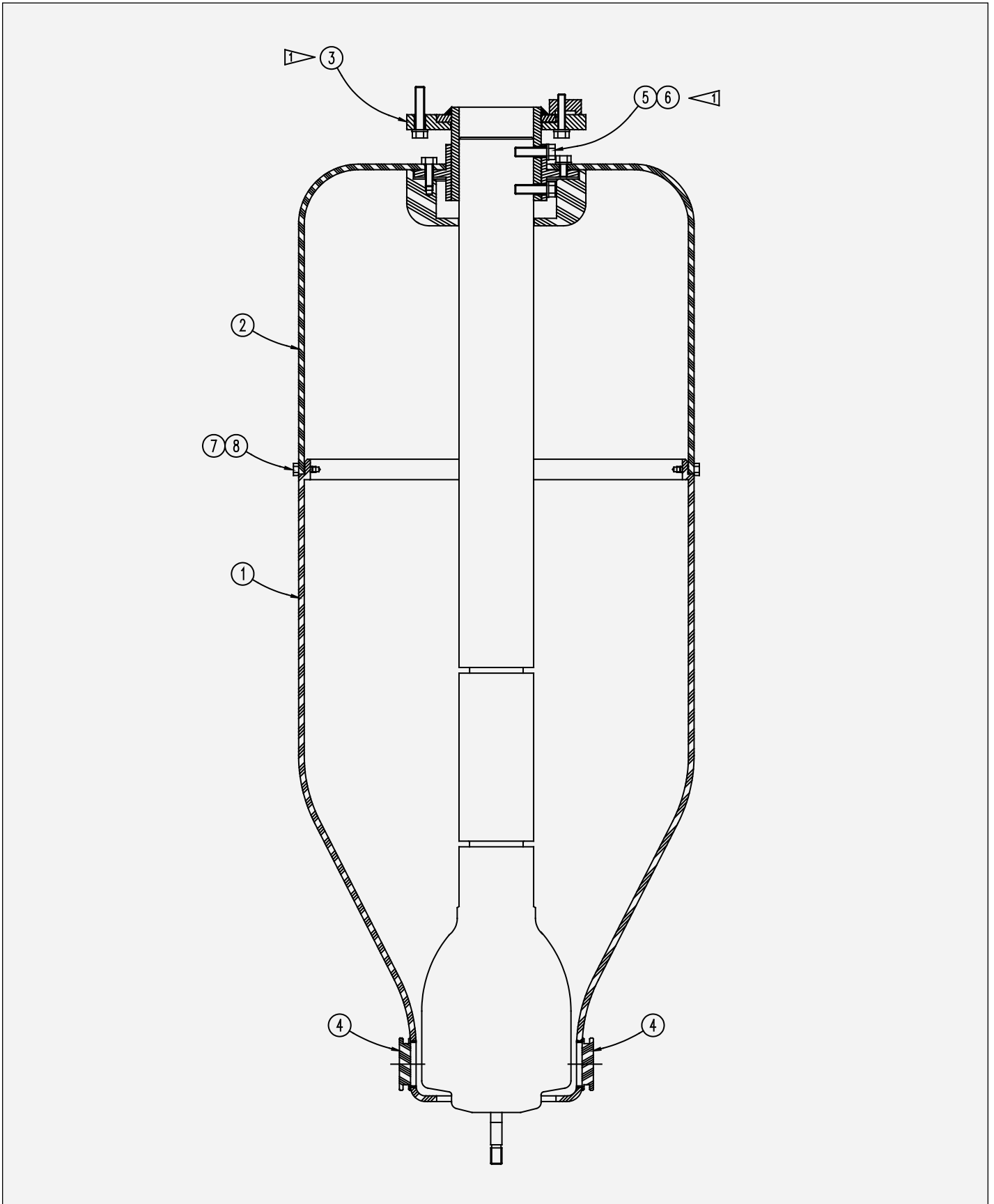

Figure 17: 70158-00 Fairing Assembly

70158-00 FAIRING ASSEMBLY - PARTS LIST (Figure 17)

Item #	Part #	Description	Qty	
1	70157-02	Fairing	1	
2	70155-02	Bulkhead	1	
3	70381-00	Flange Support	1	
4	70909-00	Plug, Machined, Feed Tube Adjustment	2	
1	5	8156-32F	Screw, 5/16-24 X 1" Lg. Hex Head	2
1	6	7734-07	Lock Washer, 5/16" Helical Spring	2
7	70656-32C	Screw, Nylon, 3/8-16 X 1" Lg. Hex Head	6	
8	20559-09	Washer, Nylon, Flat, 3/8" ID	6	
9	AU-81-02.1	Service Literature (Not Shown)	1	

1 On up-feed assemblies, use 70913 (Ref.) feed tube bracket (1 Required) & 70914-01 (Ref.) clockwise feed tube or 70914-02 (Ref.) counter-clockwise feed tube on air motor.

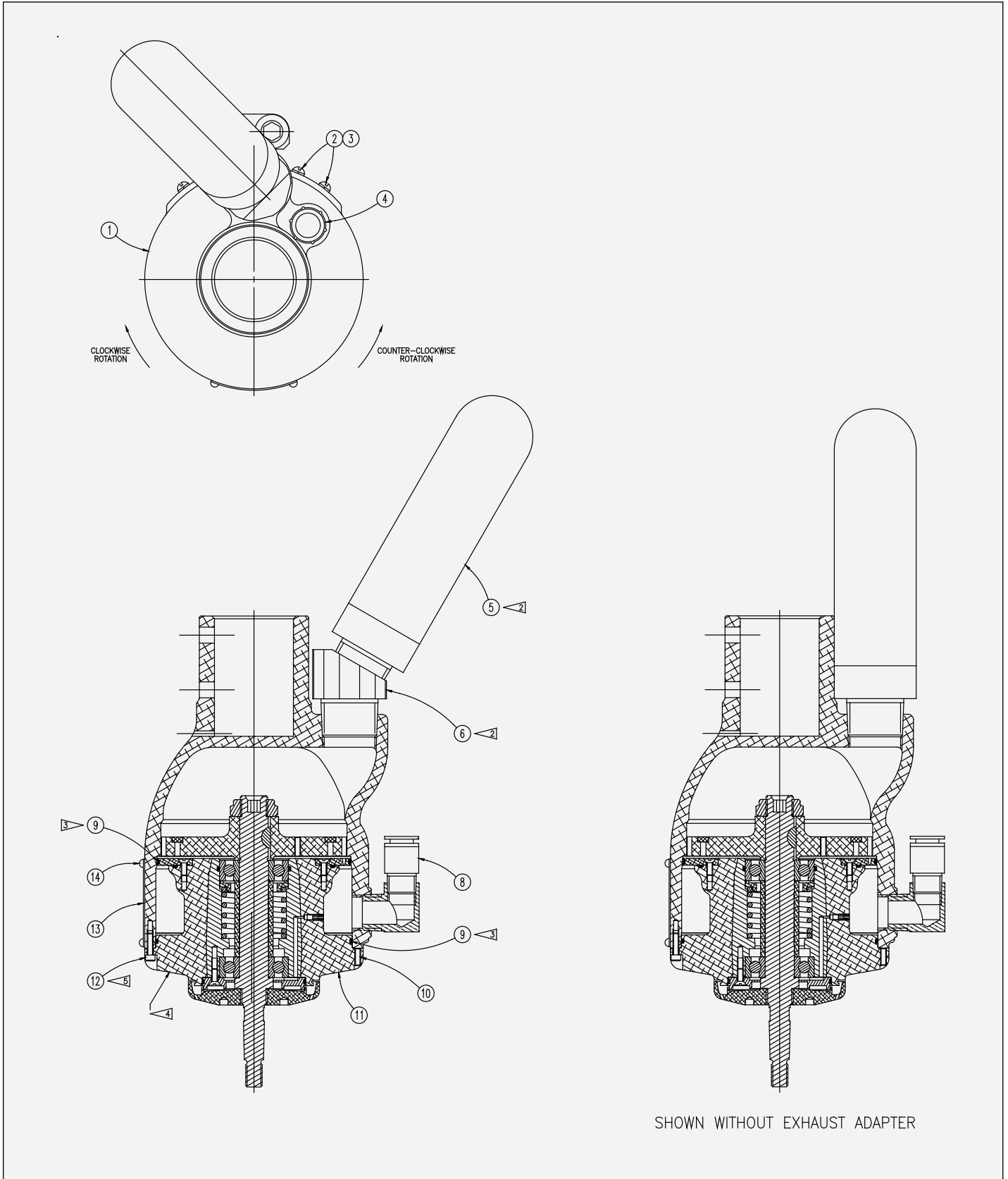

Figure 18: 78175-XX TurboDisk Air Turbine Assembly

78175-XX TURBODISK AIR TURBINE ASSEMBLY - PARTS LIST (Figure 18)

Item #	Description	Part #	Qty
1	Housing Assembly, Machined, TurboDisk Upgrade	78174-00	1
2	Screw, #8-32 x 5/16" Long, Slotted Round Head	7735-10C	8
3	Lock Washer, #8 Helical Spring	7734-03	8
4	Plug, Protective	LS0135	1
2	5 Muffler, 1" NPT Polyethylene Exhaust	78163-00	1
6	Fitting, Machined, Exhaust Muffler Adapter	78173-00	A*
8	Fitting, 1/2" NPT x 1/2" OD Tube	78168-00	2
3	9 O-Ring, 4.239" ID x .070" CS, Solvent Resistant	7554-74	2
10	Screw, #8-32 x 3/8" Long, Socket Head Set	7716-12C	3
11	Air Motor Assembly, TurboDisk	B*	1
5	12 Screw, #6-32 x 1/2" Long, Socket Head Cap	10773-16C	6
13	Nameplate, TurboDisk	70870-00	1
14	Drive Screw	7612-43	4

* See corresponding column in Table "A"

TABLE "A" (Figure 18)

Item #	Description	A	B
78175-01	Air Motor Assembly, Clockwise Rotation, without Exhaust Adapter	0	70879-406
1	78175-02 Air Motor Assembly, Clockwise Rotation, with Exhaust Adapter	1	70879-406
78175-11	Air Motor Assembly, Counter-Clockwise Rotation, without Exhaust Adapter	0	70879-456
1	78175-12 Air Motor Assembly, Counter-Clockwise Rotation, with Exhaust Adapter	1	70879-456

** See "Parts List Bullet Definition Table"

5 Tighten screws alternately to a final torque reading of 10 lbs•in (1.13 Nm).

3 Apply Petrolatum jelly, SSL-11, to o-rings prior to assembly.

2 Apply 7969-10 thread sealer to male pipe threads prior to assembly.

1 The exhaust adapter is required only when the orientation of the fluid valving will not allow the exhaust muffler to be installed directly into the turbine housing. If the installed system provides an interference, then it may be possible to re-orient the fluid valving so that the exhaust adapter is not required.

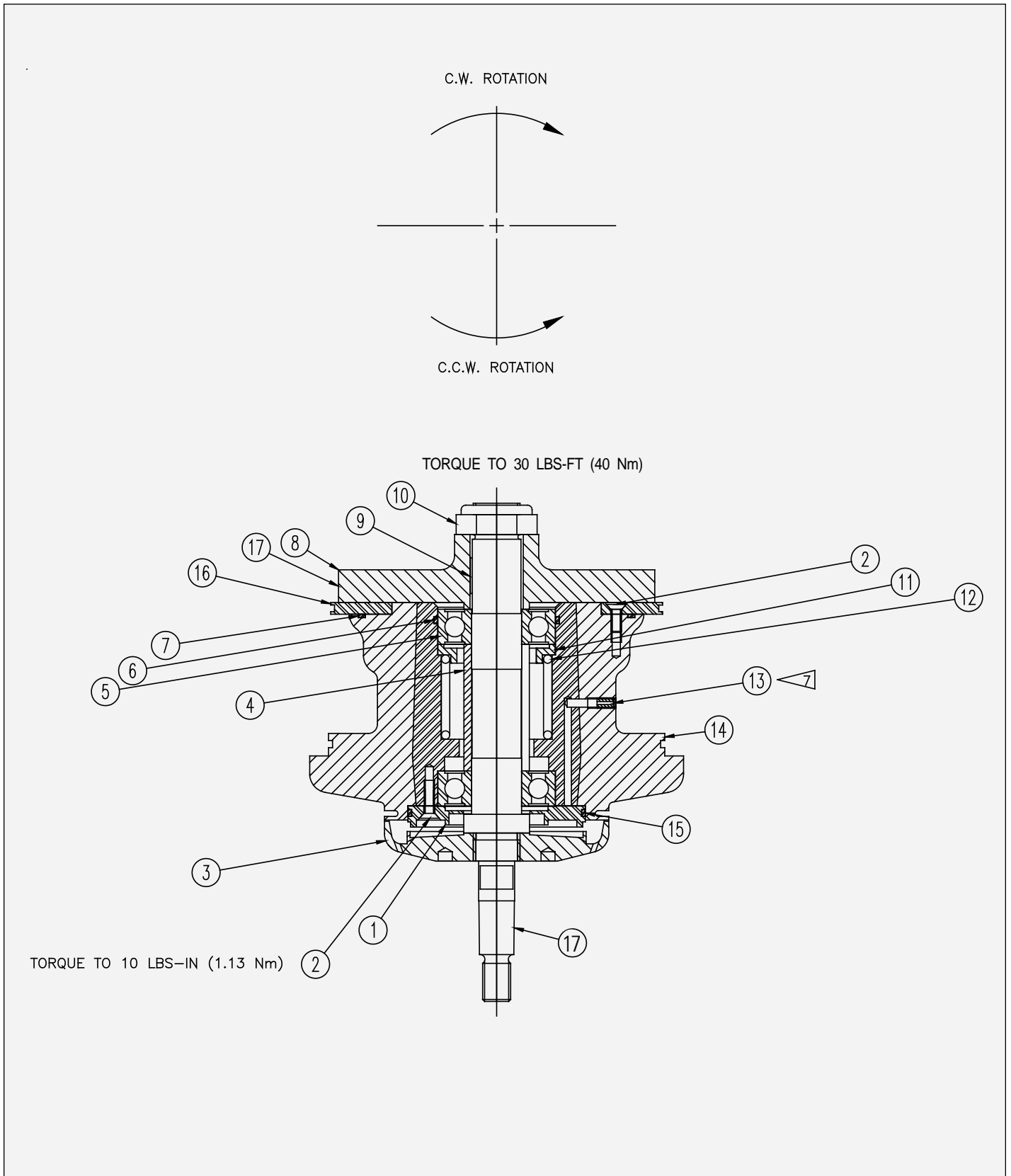

Figure 19: 70879-XXX TurboDisk Turbine Cartridge Assembly

70879-XXX TURBODISK TURBINE CARTRIDGE ASSEMBLY - PARTS LIST (Figure 19)

Item #	Description	Part #	Qty	
1	Retainer, Bearing	70873-00	1	
9	2	Screw, #6-32 x 3/8" Long, Hex Socket, Flat Head	78232-12C	12
3	Slinger	70876-00	1	
4	Spacer, Bearing	20298-00	1	
5	Bearing, Ball	70896-00	2	
6	6	O-Ring, 1.614" ID, Solvent Resistant	7554-77	1
7	O-Ring, 3.489" ID, Solvent Resistant	7554-73	1	
8	Decal, 20292-xx TurboDisk	73180-02	1	
7	9	Key, Woodruff, 1/2" Dia.	8310-01	1
10	Nut, Self-Lock, 5/8-18, UNF	7729-10	1	
11	Seat, Spring	20966-00	1	
12	Spring, Compression	70868-00	1	
13	Screw, Set, Special	70871-00	1	
14	Housing, Bearing, Machined	70875-00	1	
15	O-Ring, 2.239" ID, Solvent Resistant	7554-17	1	
16	Plate, Nozzle	A*	1	
17	Shaft, Air Motor	C*	1	

* See corresponding column in Table "A"

TABLE "A" (Figure 19)

Item #	Description	A	C
8	70879-406 Motor, TurboDisk, Clockwise Rotation	20291-10	70897-01
8	70879-456 Motor, TurboDisk, Counter-Clockwise Rotation	20291-60	70897-02

** See "Parts List Bullet Definition"

9 Prime thread with P/N 7991-00 primer (Loctite 19267) and bond with P/N 7969-03 Loctite (Blue 24077)

8 These denote magnetic/fiber optic assemblies.

7 Apply 7969-02 (Red 27121) Loctite to threads.

6 This o-ring to be assembled dry.

TURBODISK APPLICATOR RECOMMENDED SPARE PARTS

Part #	Description	Qty
CCV-403-SS	Trigger Valve	0
KK-4841	CCV Valve Repair Kit	0-1
73913-00	DR-1 Regulator Rebuild Kit	0-1
SSW-1064	High Voltage Cable	
SSV-809	Check Valve	0-1
SMC-29	Fiber Optic Pickup	0-1
70977-04	Tube, 3/8" OD	
70977-05	Tube, 1/2" OD	
70977-06	Tube, 1/4" OD	
18283-02	Valve Assembly, 3-Way	1
Select Option Below - Fluid Regulator		
74151-01	DR-1 Regulator 1:2 Ratio	1
74151-02	DR-1 Regulator 1:4 Ratio	1
74151-03	DR-1 Regulator 1:6 Ratio	1
74151-04	DR-1 Regulator 1:8 Ratio	1
74151-05	DR-1 Regulator 1:10 Ratio	1
74151-06	DR-1 Regulator 1:3 Ratio	1
74151-11	DR-1 Regulator 1:1 Ratio	1
70171-04	High Flow Fluid Regulator	1
Select Option Below - Disk		
20485-62	Disk Assembly, Serrated, 6", Aluminum, Not Anodized	0-1
20485-65	Disk Assembly, Serrated, 6", Aluminum, Anodized	0-1
20485-92	Disk Assembly, Serrated, 9", Aluminum, Not Anodized	0-1
20485-95	Disk Assembly, Serrated, 9", Aluminum, Anodized	0-1
20485-122	Disk Assembly, Serrated, 12", Aluminum, Not Anodized	0-1
20485-125	Disk Assembly, Serrated, 12", Aluminum, Anodized	0-1
19830-06	Uni-Disk Assembly, 6", Aluminum, Not Anodized	0-1
19830-08	Uni-Disk Assembly, 8", Aluminum, Not Anodized	0-1
19830-10	Uni-Disk Assembly, 10", Aluminum, Not Anodized	0-1
19830-12	Uni-Disk Assembly, 12", Aluminum, Not Anodized	0-1
Select Option Below - Disk Motor		
70879-406	Air Motor, High Speed, Clockwise Rotation	1
70879-456	Air Motor, High Speed, Counter-Clockwise Rotation	1
Select Option Below - Feed Tube Kit		
70976-01	Feed Tube Kit, Overhead Installation	0-1
70986-02	Feed Tube Kit, Pit Mount Installation, Clockwise Rotation	0-1
70986-03	Feed Tube Kit, Pit Mount Installation, Counter-Clockwise Rotation	0-1

TOOLS AND ACCESSORIES

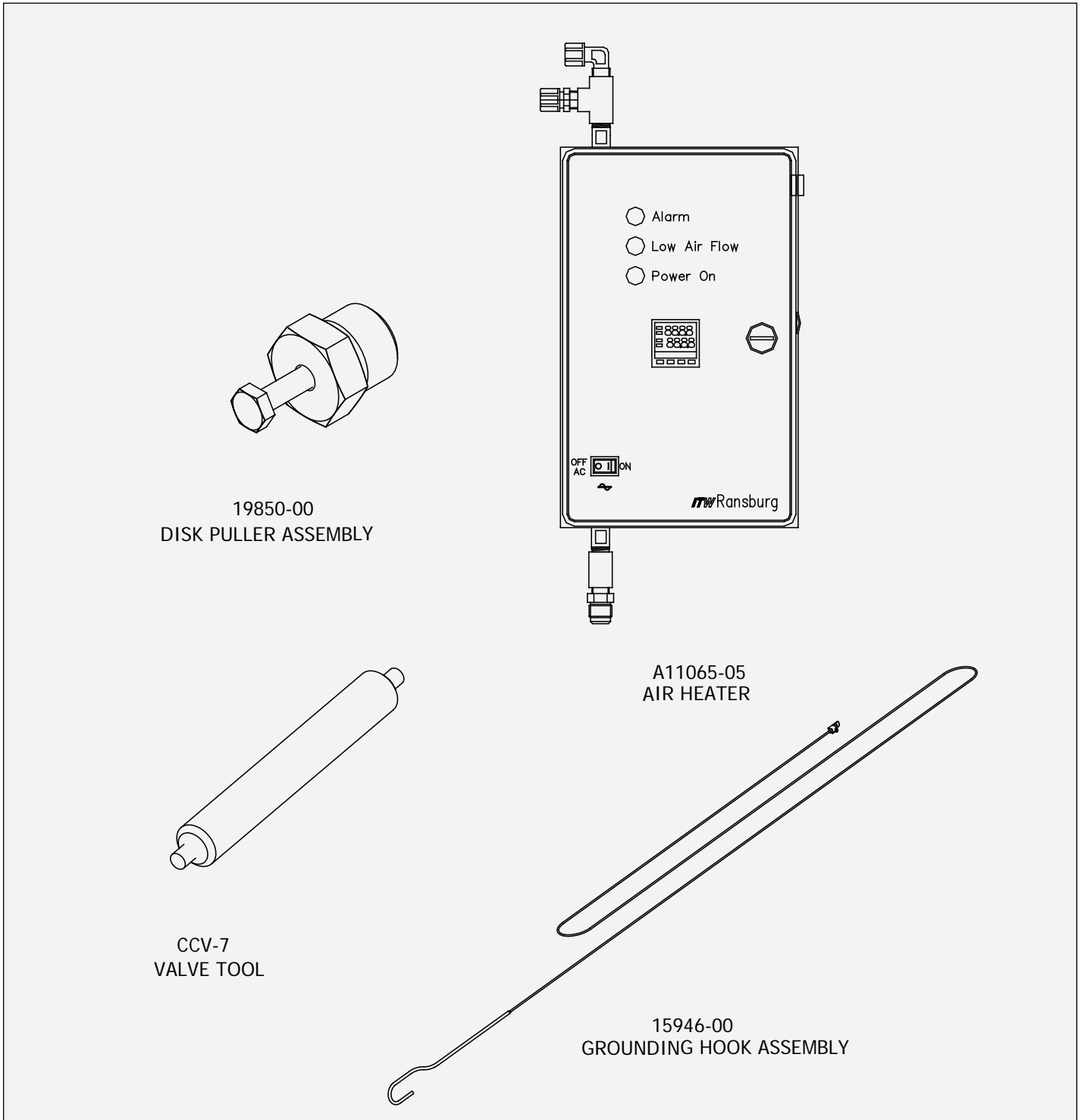

MANUAL CHANGE SUMMARY

AA-07-02-R3 - Replaces AA-07-02.2 with the following changes:

No.	Change Description	Page(s)
1.	Update to most current manual design	All
2.	Make corrections to text column 1 last paragraph and "Power Supply and Controls" text	10
3.	Insert new page "APPROVALS" after page 10	11
4.	Update SPECIFICATIONS text and change first NOTE to a WARNING and update text	12
5.	Update CONICAL DISK tables	12-13
6.	Update WARNING and add "Voltage Interlocks" copy	14
7.	Add WARNING from page 19	14

WARRANTY POLICY

This product is covered by Carlisle Fluid Technologies' materials and workmanship limited warranty. The use of any parts or accessories, from a source other than Carlisle Fluid Technologies, will void all warranties. Failure to reasonably follow any maintenance guidance provided, may invalidate any warranty.

For specific warranty information please contact Carlisle Fluid Technologies.

For technical assistance or to locate an authorized distributor, contact one of our international sales and customer support locations.

Region	Industrial / Automotive	Automotive Refinishing
Americas	Tel: 1-800-992-4657 Fax: 1-888-246-5732	Tel: 1-800-445-3988 Fax: 1-800-445-6643
Europe, Africa Middle East, India	Tel: +44 (0)1202 571 111 Fax: +44 (0)1202 573 488	
China	Tel: +8621-3373 0108 Fax: +8621-3373 0308	
Japan	Tel: +81 45 785 6421 Fax: +81 45 785 6517	
Australia	Tel: +61 (0) 2 8525 7555 Fax: +61 (0) 2 8525 7575	

For the latest information about our products, visit www.carlisleft.com.

Carlisle Fluid Technologies is a global leader in innovative finishing technologies.
Carlisle Fluid Technologies reserves the right to modify equipment specifications without prior notice.

BGK™, Binks®, DeVilbiss®, Hosco®, MS®, and Ransburg®
are registered trademarks of Carlisle Fluid Technologies, LLC.

©2023 Carlisle Fluid Technologies, LLC.
All rights reserved.



16430 North Scottsdale Rd.
Scottsdale, AZ 85254 USA