

RMA-570 ROBOT MOUNTED ROTARY ATOMIZER INDIRECT CHARGE

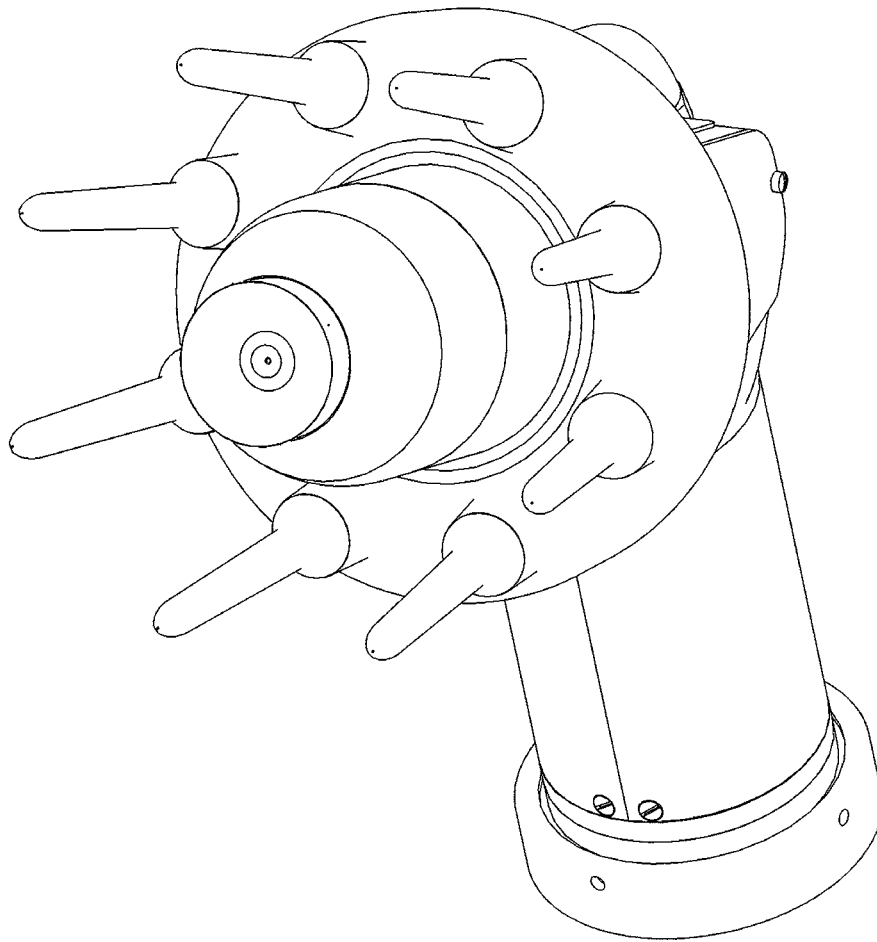

MODEL: A13365

IMPORTANT: Before using this equipment, carefully read SAFETY PRECAUTIONS, starting on page 1, and all instructions in this manual. Keep this Service Manual for future reference.

Service Manual Price: \$50.00 (U.S.)

NOTE: This manual has been changed from revision LN-9275-13.1 to revision LN-9275-13.2. Reasons for this change are noted under “Manual Change Summary” on page 100 of this manual.

CONTENTS

	PAGE
SAFETY:	1-5
SAFETY PRECAUTIONS	1
HAZARDS / SAFEGUARDS	2-5
INTRODUCTION:	6-20
APPLICATOR DESCRIPTION	6
FEATURES	6
GENERAL DESCRIPTION	7-8
SPECIFICATIONS	9-10
IMPORTANT NUMBERS	11
GRAPHS	12-16
RMA-570 INDIRECT TOOL POINT DIMENSIONS	17-18
CIRCUIT DIAGRAM	19
VALVE SCHEMATICS	20
INSTALLATION:	21-30
AIR FILTER INSTALLATION	21
TUBE SIZE / AIR PRESSURE REQUIREMENTS	21
EQUIPMENT GROUNDING / SAFETY RECOMMENDATIONS	22-23
AIR HEATER REQUIREMENTS	23
AIR HEATER AND FILTRATION OPTIONS	24-26
MOUNTING	26
ELECTRICAL AND FIBER OPTIC CONNECTIONS	26-27
FLUID CONNECTIONS	27
TYPICAL INSTALLATION	27-28
TUBING BUNDLE INSTALLATION	29
BUNDLE LUBRICANT	29
INTERLOCKS	29-30
OPERATION:	31-39
FLUID FLOW RATE CONTROL	31
FLUID VALVE CONTROL	32
TURBINE SPEED	33
BEARING AIR ADJUSTMENT	33
SHAPING AIR KITS #1, #2 AND #3	34-36
BRAKE AIR	37
ELECTROSTATIC VOLTAGE	37
TARGET DISTANCE	37
GENERAL OPERATING SEQUENCE	37-39
PROTECTIVE COVERS	39

(Continued On Next Page)

CONTENTS (Cont.)

	PAGE
MAINTENANCE:	40-74
O-RINGS	40
CLEANING PROCEDURES.....	40-41
VIBRATION NOISE	41
TURBINE MAINTENANCE.....	42
GENERAL MAINTENANCE	42
PREVENTIVE MAINTENANCE.....	42-44
BELL CUP PREVENTATIVE MAINTENANCE	44
BELL CUP CLEANING	45-46
CLEANING SHAPING AIR HOLES.....	46
RMA-570 PREVENTATIVE MAINTENANCE SCHEDULE.....	47-48
DISASSEMBLY PROCEDURES	48-50
HIGH VOLTAGE CONNECTIONS FOR SHIELDED/ NON-METALLIC CORE CABLE	51-65
CHECKING PROBES.....	66
ELECTRODE RESISTANCE TEST.....	66-67
OPERATOR MAINTENANCE WARNINGS.....	68
TUBING BUNDLE ASSEMBLY	69-70
TROUBLE SHOOTING GUIDE.....	71-74
PARTS IDENTIFICATION:	75-101
RMA-570 INDIRECT CHARGE ROTARY ATOMIZER MODEL IDENTIFICATION	75-77
RMA-570 ASSEMBLY / PARTS LIST	78-82
TYPICAL BELL CUP PARTS BREAKDOWN	83
A13453-00 REAR PLATE ASSEMBLY PARTS LIST.....	84
A13451-00 APPLICATOR MOUNTING ASSEMBLY - PARTS LIST.....	85
A11692-00 VALVE MANIFOLD ASSEMBLY - PARTS LIST	86-87
A13454-XXXXX TUBING BUNDLE ASSEMBLY - PARTS LIST.....	88-89
A13454-XXXXXXX TUBING BUNDLE ASSEMBLY MODEL IDENTIFICATION	90-92
ATOMIZER RECOMMENDED SPARE PARTS.....	93-95
BELL CUP SPARE PARTS LIST	96
TUBE BUNDLE SPARE PARTS LIST	97-98
A11536-XX HIGH VOLTAGE RING KIT - PARTS LIST.....	99
ELECTRODE ASSEMBLY - PARTS LIST	99
SERVICE KITS.....	100
FILTER & HEATER ASSEMBLY A13230-XX.....	101
A13230-XX AIR HEATER AND FILTER COMBINATION	101
WARRANTY POLICIES:	102
LIMITED WARRANTY	102

SAFETY

SAFETY PRECAUTIONS

Before operating, maintaining or servicing any Ransburg electrostatic coating system, read and understand all of the technical and safety literature for your Ransburg products. This manual contains information that is important for you to know and understand. This information relates to USER SAFETY and PREVENTING EQUIPMENT PROBLEMS. To help you recognize this information, we use the following symbols. Please pay particular attention to these sections.

A WARNING! States information to alert you to a situation that might cause serious injury if instructions are not followed.

A CAUTION! States information that tells how to prevent damage to equipment or how to avoid a situation that might cause minor injury.

A NOTE is information relevant to the procedure in progress.

While this manual lists standard specifications and service procedures, some minor deviations may be found between this literature and your equipment. Differences in local codes and plant requirements, material delivery requirements, etc., make such variations inevitable. Compare this manual with your system installation drawings and appropriate Ransburg equipment manuals to reconcile such differences.

Careful study and continued use of this manual will provide a better understanding of the equipment and process, resulting in more efficient operation, longer trouble-free service and faster, easier troubleshooting. If you do not have the manuals and safety literature for your Ransburg system, contact your local Ransburg representative or Ransburg.



WARNING

- The user **MUST** read and be familiar with the Safety Section in this manual and the Ransburg safety literature therein identified.
- This manual **MUST** be read and thoroughly understood by **ALL** personnel who operate, clean or maintain this equipment! Special care should be taken to ensure that the **WARNINGS** and safety requirements for operating and servicing the equipment are followed. The user should be aware of and adhere to ALL local building and fire codes and ordinances as well as **NFPA-33 SAFETY STANDARD, LATEST EDITION**, prior to installing, operating, and/or servicing this equipment.



WARNING

- The hazards shown on the following pages may occur during the normal use of this equipment. Please read the hazard chart beginning on page 2.

<p>AREA Tells where hazards may occur.</p>	<p>HAZARD Tells what the hazard is.</p>	<p>SAFEGUARDS Tells how to avoid the hazard.</p>
<p>Spray Area</p> 	<p>Fire Hazard</p> <p>Improper or inadequate operation and maintenance procedures will cause a fire hazard.</p> <p>Protection against inadvertent arcing that is capable of causing fire or explosion is lost if any safety interlocks are disabled during operation. Frequent Power Supply or Controller shutdown indicates a problem in the system requiring correction.</p>	<p>Fire extinguishing equipment must be present in the spray area and tested periodically.</p> <p>Spray areas must be kept clean to prevent the accumulation of combustible residues.</p> <p>Smoking must never be allowed in the spray area.</p> <p>The high voltage supplied to the atomizer must be turned off prior to cleaning, flushing or maintenance.</p> <p>When using solvents for cleaning:</p> <ul style="list-style-type: none"> • Those used for equipment flushing should have flash points equal to or higher than those of the coating material. • The flash point of the cleaning solvent shall be at least 15° C (27° F) above the ambient temperature. Otherwise, the cleaning process must be carried out in an area with forced air ventilation. It is the end users responsibility to insure this condition is met. <p>Spray booth ventilation must be kept at the rates required by NFPA-33, OSHA, country, and local codes. In addition, ventilation must be maintained during cleaning operations using flammable or combustible solvents.</p> <p>Electrostatic arcing must be prevented. Safe sparking distance must be maintained between the parts being coated and the applicator. A distance of 1 inch for every 10KV of output voltage is required at all times.</p> <p>Test only in areas free of combustible material. Testing may require high voltage to be on, but only as instructed.</p> <p>Non-factory replacement parts or unauthorized equipment modifications may cause fire or injury.</p> <p>If used, the key switch bypass is intended for use only during setup operations. Production should never be done with safety interlocks disabled.</p> <p>Never use equipment intended for use in waterborne installations to spray solvent based materials.</p> <p>The paint process and equipment should be set up and operated in accordance with NFPA-33, NEC, OSHA, local, country, and European Health and Safety Norms.</p>

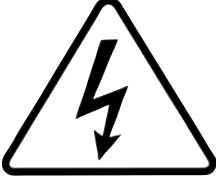
<p>AREA Tells where hazards may occur.</p>	<p>HAZARD Tells what the hazard is.</p>	<p>SAFEGUARDS Tells how to avoid the hazard.</p>
<p>Spray Area</p> 	<p>Explosion Hazard</p> <p>Improper or inadequate operation and maintenance procedures will cause a fire hazard.</p> <p>Protection against inadvertent arcing that is capable of causing fire or explosion is lost if any safety interlocks are disabled during operation.</p> <p>Frequent Power Supply or Controller shutdown indicates a problem in the system requiring correction.</p>	<p>Electrostatic arcing must be prevented. Safe sparking distance must be maintained between the parts being coated and the applicator. A distance of 1 inch for every 10KV of output voltage is required at all times.</p> <p>Unless specifically approved for use in hazardous locations, all electrical equipment must be located outside Class I or II, Division 1 or 2 hazardous areas, in accordance with NFPA-33.</p> <p>Test only in areas free of flammable or combustible materials.</p> <p>The current overload sensitivity (if equipped) MUST be set as described in the corresponding section of the equipment manual. Protection against inadvertent arcing that is capable of causing fire or explosion is lost if the current overload sensitivity is not properly set. Frequent power supply shutdown indicates a problem in the system which requires correction.</p> <p>Always turn the control panel power off prior to flushing, cleaning, or working on spray system equipment.</p> <p>Before turning high voltage on, make sure no objects are within the safe sparking distance.</p> <p>Ensure that the control panel is interlocked with the ventilation system and conveyor in accordance with NFPA-33, EN 50176.</p> <p>Have fire extinguishing equipment readily available and tested periodically.</p>
<p>General Use and Maintenance</p> 	<p>Improper operation or maintenance may create a hazard.</p> <p>Personnel must be properly trained in the use of this equipment.</p>	<p>Personnel must be given training in accordance with the requirements of NFPA-33, EN 60079-0.</p> <p>Instructions and safety precautions must be read and understood prior to using this equipment.</p> <p>Comply with appropriate local, state, and national codes governing ventilation, fire protection, operation maintenance, and housekeeping. Reference OSHA, NFPA-33, EN Norms and your insurance company requirements.</p>

<p>AREA Tells where hazards may occur.</p>	<p>HAZARD Tells what the hazard is.</p>	<p>SAFEGUARDS Tells how to avoid the hazard.</p>
<p>Spray Area / High Voltage Equipment</p> 	<p>Electrical Discharge</p> <p>There is a high voltage device that can induce an electrical charge on ungrounded objects which is capable of igniting coating materials.</p> <p>Inadequate grounding will cause a spark hazard. A spark can ignite many coating materials and cause a fire or explosion.</p>	<p>Parts being sprayed and operators in the spray area must be properly grounded.</p> <p>Parts being sprayed must be supported on conveyors or hangers that are properly grounded. The resistance between the part and earth ground must not exceed 1 meg ohm. (Refer to NFPA-33.)</p> <p>Operators must be grounded. Rubber soled insulating shoes should not be worn. Grounding straps on wrists or legs may be used to assure adequate ground contact.</p> <p>Operators must not be wearing or carrying any ungrounded metal objects.</p> <p>When using an electrostatic handgun, operators must assure contact with the handle of the applicator via conductive gloves or gloves with the palm section cut out.</p> <p>NOTE: REFER TO NFPA-33 OR SPECIFIC COUNTRY SAFETY CODES REGARDING PROPER OPERATOR GROUNDING.</p> <p>All electrically conductive objects in the spray area, with the exception of those objects required by the process to be at high voltage, must be grounded. Grounded conductive flooring must be provided in the spray area.</p> <p>Always turn off the power supply prior to flushing, cleaning, or working on spray system equipment.</p> <p>Unless specifically approved for use in hazardous locations, all electrical equipment must be located outside Class I or II, Division 1 or 2 hazardous areas, in accordance with NFPA-33.</p>

<p>AREA Tells where hazards may occur.</p>	<p>HAZARD Tells what the hazard is.</p>	<p>SAFEGUARDS Tells how to avoid the hazard.</p>
<p>Electrical Equipment</p> 	<p>Electrical Discharge</p> <p>High voltage equipment is utilized in the process. Arcing in the vicinity of flammable or combustible materials may occur. Personnel are exposed to high voltage during operation and maintenance.</p> <p>Protection against inadvertent arcing that may cause a fire or explosion is lost if safety circuits are disabled during operation.</p> <p>Frequent power supply shut-down indicates a problem in the system which requires correction.</p> <p>An electrical arc can ignite coating materials and cause a fire or explosion.</p>	<p>Unless specifically approved for use in hazardous locations, the power supply, control cabinet, and all other electrical equipment must be located outside Class I or II, Division 1 and 2 hazardous areas in accordance with NFPA-33 and EN 50176.</p> <p>Turn the power supply OFF before working on the equipment.</p> <p>Test only in areas free of flammable or combustible material.</p> <p>Testing may require high voltage to be on, but only as instructed.</p> <p>Production should never be done with the safety circuits disabled.</p> <p>Before turning the high voltage on, make sure no objects are within the sparking distance.</p>
<p>Toxic Substances</p> 	<p>Certain material may be harmful if inhaled, or if there is contact with the skin.</p>	<p>Follow the requirements of the Material Safety Data Sheet supplied by coating material manufacturer.</p> <p>Adequate exhaust must be provided to keep the air free of accumulations of toxic materials.</p> <p>Use a mask or respirator whenever there is a chance of inhaling sprayed materials. The mask must be compatible with the material being sprayed and its concentration. Equipment must be as prescribed by an industrial hygienist or safety expert, and be NIOSH approved.</p>
<p>Spray Area</p> 	<p>Explosion Hazard – Incompatible Materials</p> <p>Halogenated hydrocarbon solvents for example: methylene chloride and 1,1,1,-Trichloroethane are not chemically compatible with the aluminum that might be used in many system components. The chemical reaction caused by these solvents reacting with aluminum can become violent and lead to an equipment explosion.</p>	<p>Aluminum is widely used in other spray application equipment - such as material pumps, regulators, triggering valves, etc. Halogenated hydrocarbon solvents must never be used with aluminum equipment during spraying, flushing, or cleaning. Read the label or data sheet for the material you intend to spray. If in doubt as to whether or not a coating or cleaning material is compatible, contact your coating supplier. Any other type of solvent may be used with aluminum equipment.</p>

INTRODUCTION

APPLICATOR DESCRIPTION

The RMA-570 is an automatic robot mountable rotary atomizer capable of spraying waterborne coatings electrostatically or non-electrostatically. It incorporates the latest in high speed spindle technology, bell cup and shape air design to provide the best in atomization and pattern control. The bell cups are designed for durability using the best materials available. All wetted components are designed to offer the maximum in wear and chemical resistance. The applicator is capable of applying 70,000 VDC to the coating material.

FEATURES

Features which make the RMA-570 advantageous for use in electrostatic applications include:

- Assembly components made of durable engineered resin material for optimum mechanical strength and solvent resistance.
- Heavy duty design ensures excellent service life even when subjected to the quick motions of robotic applications.
- Proven long life turbine motor capable of speeds up to 100 krpm. (See "Specifications" in the "Introduction" section of this manual for bell cup speed ratings.)
- Serrated and non-serrated bell cups are available for application flexibility and color match. All bell cups are made using Titanium or Aluminum. The 55mm Bell Cup is Titanium only.
- Aerodynamic design for ease of cleaning external surfaces.
- 60° angled body provides more maneuverability and facilitates robotic programming.
- Speed control uses reliable magnetic pickup for fiber optic transmission of rotational speed data.
- Fast color changes are achieved using center feed fluid delivery and the fluid valves which provide for simultaneous paint push out while solvent washes the feed tube and bell cup interior.
- Heated bell wash material is recirculated at the robot plate. Internal solvent and air valves provide for a fast solvent/air chop method to quickly and efficiently clean the interior and exterior of the bell cup.

- Less waste to the spray booth, with the dump valve located internally next to the feed tube.
- Large range of fluid tip sizes available.
- Fitting less tubing bundle, more flexibility in the robot wrist and easier to repair damaged tubes.

The MicroPak Controller (LECU5004), in conjunction with an appropriate cascade, is used to provide high voltage for electrostatic application equipment. The controller is packaged in a single, 3.2 inch wide Eurocard module, and thus consumes less than 1/4 of the available space in a 19 inch rack.

The MicroPak uses a combination of proven high voltage generation technology including microprocessor-based control with diagnostic and communication functions. The processor circuitry provides the maximum in applicator transfer efficiency, while maintaining the maximum safety when used in conjunction with FM listed applicators.

The **Ransburg MicroPak 2e Single Bell Controller** (A13613-XX), is a free standing unit which provides voltage to a remotely located cascade and closed loop speed control for Ransburg atomizer units.

The Ransburg MicroPak 2e High Voltage Controller uses a combination of proven high voltage generation technology including microprocessor-based control with diagnostic and communication functions. A variable voltage output is used to supply a cascade that amplifies the voltage to a high value. It also uses both current and voltage feedback information to maintain the desired set point. The processor circuitry provides the maximum in applicator transfer efficiency, while maintaining the maximum safety.

The Ransburg MicroPak 2e Atomizer Controller builds upon previous Ransburg control technology and tightly integrates the MicroPak 2e Atomizer Controller with the MicroPak 2e High Voltage Controller.

GENERAL DESCRIPTION

Bell Cup Assembly

Bell cups are made of high strength Titanium or Aluminum. Serrated and non-serrated cups are available in 55mm and 65mm. See ordering matrix for exact size and material combination availability.

Air Bearing Turbine Assembly

The air bearing turbine assembly with bell cup is mounted to the air manifold assembly with a turbine retaining ring.

Air Manifold Assembly

The atomizer extension is angled at 60° for robot applications. The fluid feed tube and fiber optic turbine speed emitter are threaded into the front of the manifold. The turbine, fluid, and air manifolds are separated from the bell plate assembly by the atomizer extension.

Bell Plate Assembly

The bell plate assembly is designed to be at ground potential when mounted to the robot plate component within the tubing bundle assembly. The air and fluid ports are compactly oriented for use in robotic applications. The interior air supplies are ported through the color coded tubing directly to the air manifold assembly. On the exterior side of the bell plate, the ports are provided with O-ring seals so that the atomizer can be quickly mated and secured to the robot plate.

Robot Plate

The robot plate is a component of the tubing bundle assembly and intended to be permanently mounted to the robot. A wrist adapter is also available, which matches the robot's mounting configuration. The incoming air lines, fluid lines, and fiber optic cable are connected at the robot plate. The bell plate of the atomizer assembly is secured to the robot plate with a threaded retaining ring.

Break-Away Feature (Optional)

The RMA-570 can be converted to have a break-away feature. By replacing the six (6) stainless steel screws with six (6) special designed plastic

screws (77524-00). This feature minimizes the damage to the atomizer, robot, etc. If a collision occurs, the six (6) plastic break-away screws fail and the atomizer will break free. This will leave the break-away ring and the mounting ring attached to the robot. (The applicator will fall to the booth grate or floor.)

Power Supply and Controls

The high voltage cascade (74793-XX) is located outside the RMA-570 and is controlled by the MicroPak control unit. The low voltage output of the MicroPak is multiplied by the cascade to the high voltage level required. The high voltage is supplied to the atomizer by a high voltage cable (A10560-XX). A low voltage cable interconnects the cascade and MicroPak control. The MicroPak format is designed to fit in a conventional 19-inch or 10-inch rack and requires a 28 V power input at a maximum 6 amps.

The MicroPak is designed to electronically limit current to provide safe operation in a spray booth. The voltage and current draw of the atomizer are continuously displayed on the MicroPak control panel. Voltage and over current limits are adjustable on the front of the MicroPak. MicroPak internal safety circuits will shut down the system on over-current and cable faults.

LECU5004 (MicroPak)

The MicroPak format is designed to fit in a conventional 19-inch or 10-inch rack and requires a 28 V power input at a maximum 6 amps.

With additional control modules, all of the functions of RMA-570 and MicroPak can be controlled by a programmable controller. A Serial Atomizer module pneumatically controls the speed of the rotary atomizer with dynamic feedback through a fiber optic transmitter located on the applicator. A Serial Digital module pneumatically controls the paint, solvent, and dump valves located on the atomizer. An I/O module provides communication between these modules and the PLC.

The above modules are mounted in one 19 inch rack and interconnected through a common mother board. Reference Manual LN-9218-00.X (Latest Rev.)

The ***Ransburg MicroPak 2e Single Bell Controller*** (A13613-XX), is a free standing unit which provides voltage to a remotely located cascade and closed loop speed control for Ransburg atomizer units.

The Ransburg MicroPak 2e High Voltage Controller uses a combination of proven high voltage generation technology including microprocessor-based control with diagnostic and communication functions. A variable voltage output is used to supply a cascade that amplifies the voltage to a high value. It also uses both current and voltage feedback information to maintain the desired set point. The processor circuitry provides the maximum in applicator transfer efficiency, while maintaining the maximum safety.

The Ransburg MicroPak 2e Atomizer Controller builds upon previous Ransburg control technology and tightly integrates the MicroPak 2e Atomizer Controller with the MicroPak 2e High Voltage Controller.

The MicroPak 2e requires an AC input voltage of 90-264 VAC via a proper line cord that is supplied with the unit.

Reference Manual LN-9265-00.X (Latest Revision)

SPECIFICATIONS

Electrical:

Power Supply Type:	MicroPak and MicroPak 2e
Charging Method:	Indirect
Output Voltage:	30-70 kV Variable
Output Current:	1000 μ A
Turbine Speed Control:	Atomizer Module or by the multi-function board included in the MicrPak 2e Controller
Part Spray Ability:	Determine spray ability of part to be coated using Test Equipment (76652)

Mechanical:

Length:	(See Figure1)
Diameter:	(See Figure1)
Approximate Weight	
Atomizer Only:	18.4 lbs. (8.43Kg)
Total Payload:	21.08 lbs (9.6 Kg)
Turbine Type:	Air Bearing Impulse Drive
Turbine Air Supply:	Variable
Maximum/Minimum Turbine Speed:	Continuous
All Bell Cups:	100K rpm max.* /20K rpm min. (See exception at "Fluid Flow Rate")
	50K rpm max. with 81mm Bell Cup
Maximum Angular Velocity for Turbine (Robot Motion):	250°/sec.
Tubing Bundle Max. Rotation:	450° in Either Direction
Bearing Air Supply at Applicator:	90 psig (\pm 10 psi)
(Nominal):	(621 kPa \pm 69 kPa) 2.9 SCFM (82 slpm)
Shaping Air #1 (SAI) Supply:	Variable (See "Pressure Flow Data Charts" in the "Introduction" section)
Shaping Air #2 (SAO) Supply:	Variable (See "Pressure Flow Data Charts" in the "Introduction" section)
Brake Air Supply :	60-100 psig
(Nominal):	(414-689 kPa)
Maximum Fluid Pressure Supply:	
Paint:	200 psi (1379 kPa)
Solvent:	150 psi (1035 kPa)
Fluid Flow Rate:	25-1000 cc/min. (See exclusion below)
55 mm Bell Cup	Max. Flow Rate: 500 cc/min. at 80,000 rpm Max. Flow Rate: 800 cc/min. at 70,000 rpm
65 mm Bell Cup	Max. Flow Rate: 1000 cc/min. at 60,000 rpm Max. Flow Rate: 200 cc/min. at 100,000 rpm Max. Flow Rate: 500 cc/min. at 80,000 rpm Max. Flow Rate: 800 cc/min. at 70,000 rpm
81 mm Bell Cup	Max. Flow Rate: 600 cc/min. at 50,000 rpm

(Continued on next page)

Mechanical (Cont.):

Bell Cup Cleaning Time (Internal/External):	2.7 sec. (approx.)
Color Change Time:	Dependent on system configuration, fluid pressures, fluid viscosity, fluid line lengths, etc.
Speed Readout:	Magnetic pick-up, unidirectional fiber optic transmission
Bell Cup Replacement Time:	Less than 2 min.
Minimum Control Equipment Requirements: (Versions listed or higher)	
MicroPak	LECU5004-11 (V.3.84)
Atomizer Module	A11925-00 (V.0.4)
I/O Module	A11435-00 (V.1.4) (0.01V) (4-20 mA)
MicroPak 2e Software:	V 1.1.00 and higher
Air Heater Recommendation:	An Air Heater is recommended for the turbine air supply. See Air Heater and filtration recommendation later in this manual

* Although this turbine assembly is capable of operating at continuous speeds up to 100,000 rpm, nearly all high quality finishes can be achieved within our recommended operating range of 20,000 to 70,000 rpm, based on experience with a wide variety of materials and various markets. Operating above this range is for highly specialized applications, and may reduce efficiency and equipment life. Contact your Ransburg representative for additional information as required.

The air turbine only is warranted for 15,000 operating hours, or 3 years from date of first installation, whichever occurs first. If, after inspection by Ransburg, defect is confirmed, we will repair or replace the air turbine, free of charge, during the warranty period. The repaired air turbine (or replacement air turbine) will continue to be warranted for the remainder of the initial warranty period (from installation date). The warranty period for the air turbine does not begin again when a repair is completed under warranty. Air turbines repaired by Ransburg after the warranty period will be warranted for 90 days from the date of shipment from the repair center. (See Warranty section on last page for specific exclusions)

Specifications and ratings based on testing at sea level standard conditions.

**

IMPORTANT NUMBERS

Record these numbers in a log book for future reference.

The last digits of the Atomizer serial number are also the Turbine serial numbers.

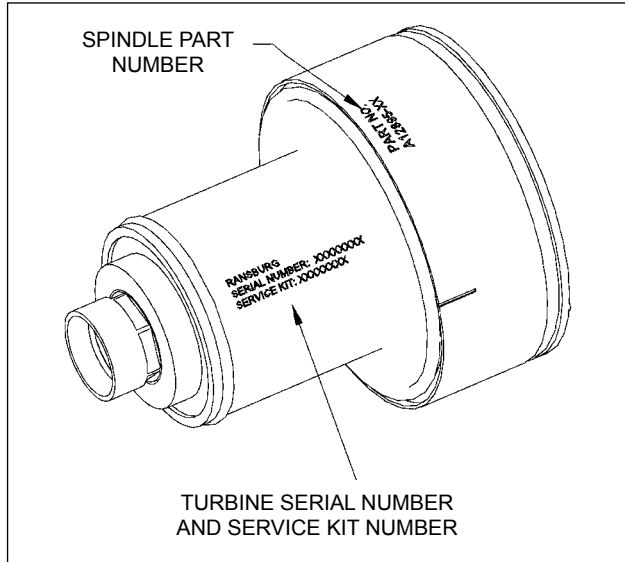

Turbine Serial Number

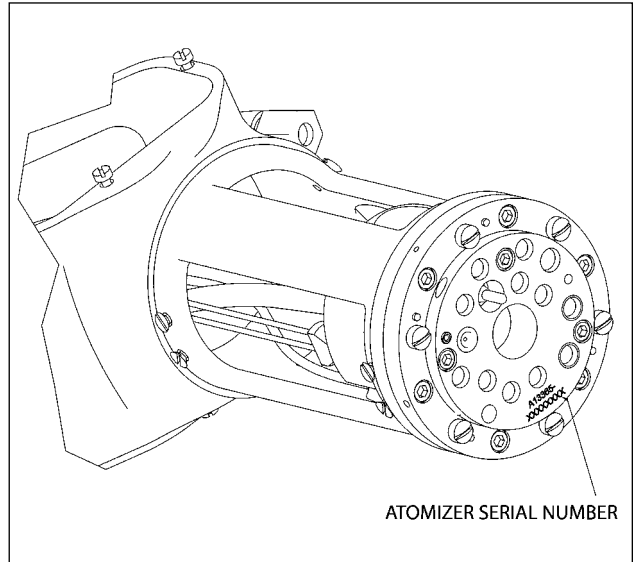

Atomizer Serial Number

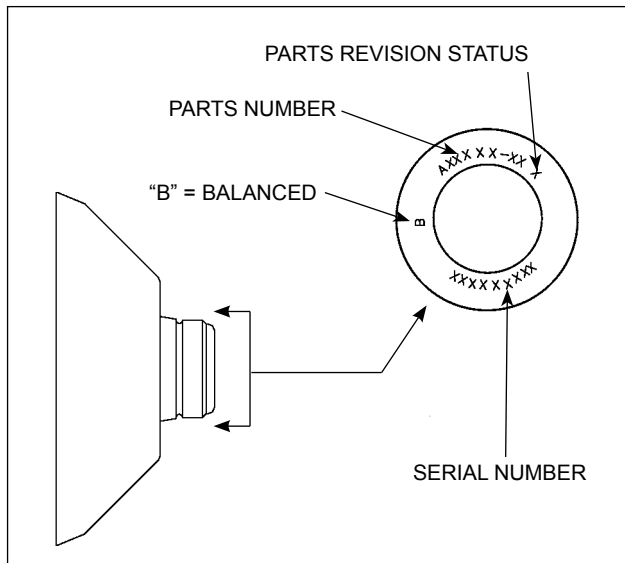

**Bell Cup Part Numbers/Serial Number
(Cup only, not with splash plate)**

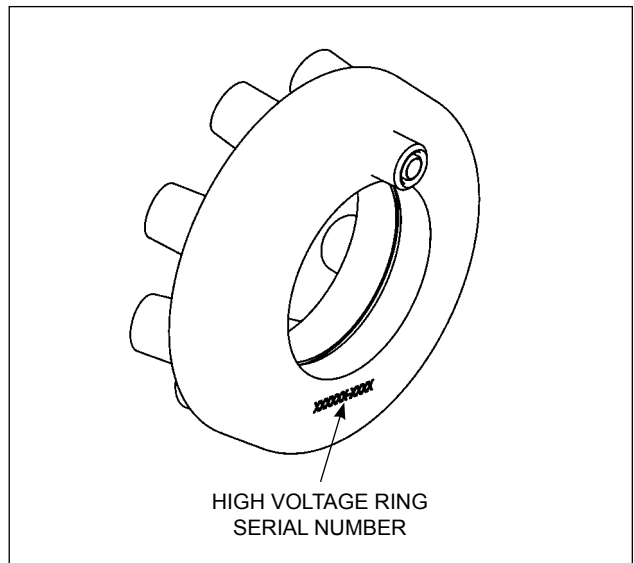

High Voltage Serial Number

GRAPHS

Graphical information provided for reference only for all charts. Unless otherwise specified, all pressure data shown was measured 12-inches (305mm) behind the applicator.

TURBINE SPEED VS. PRESSURE - NO LOAD

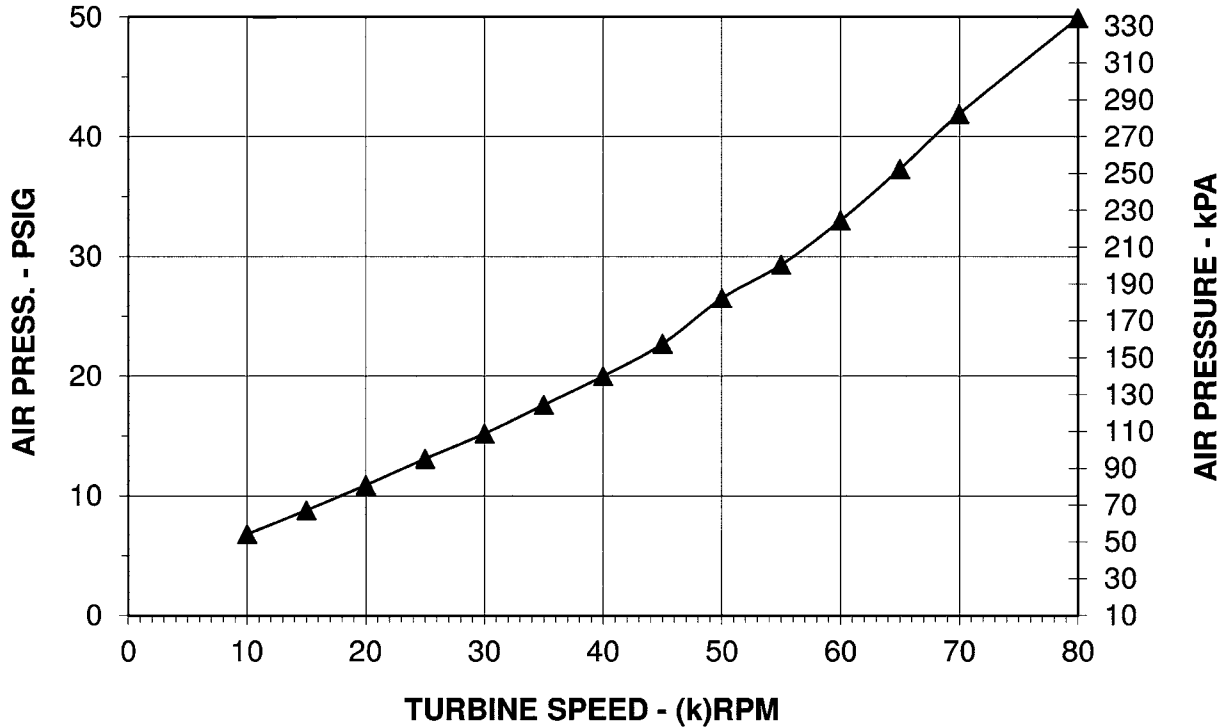

TURBINE SPEED VS. AIR CONSUMPTION - NO LOAD

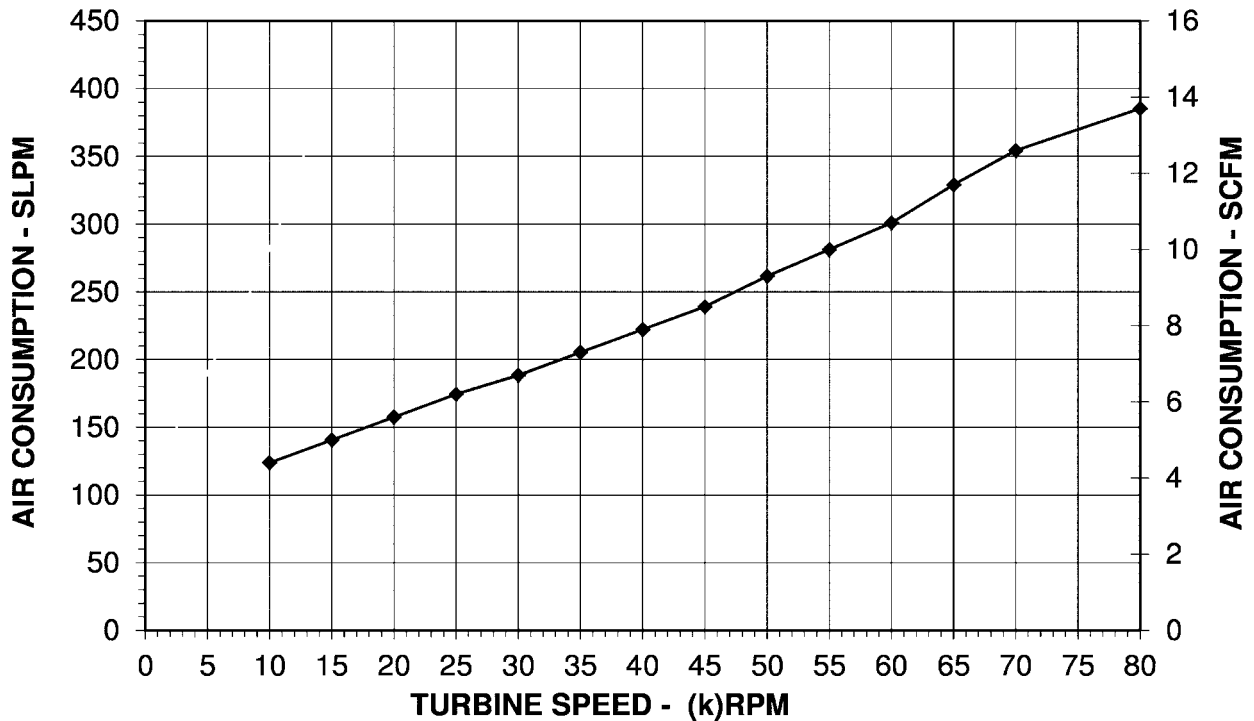

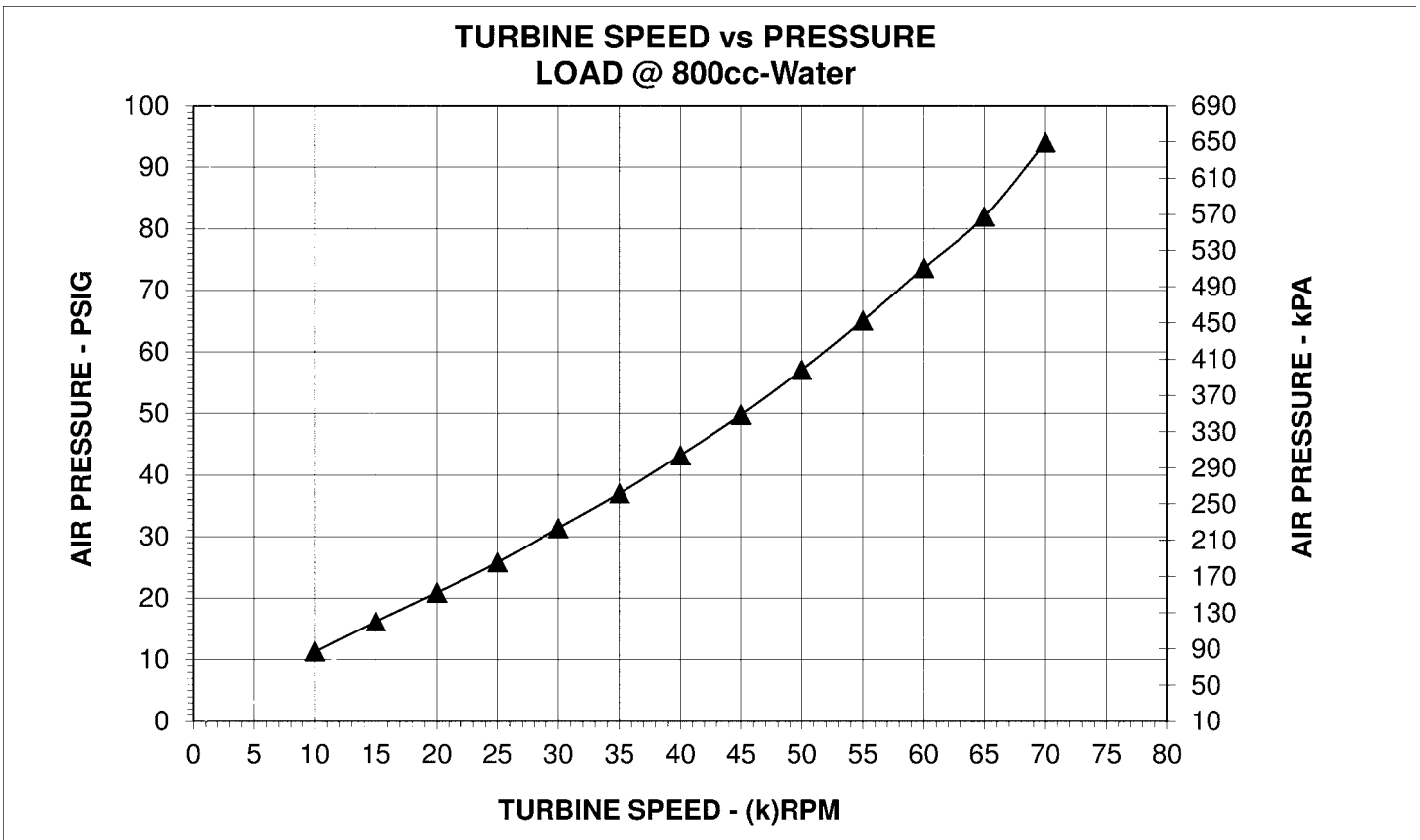
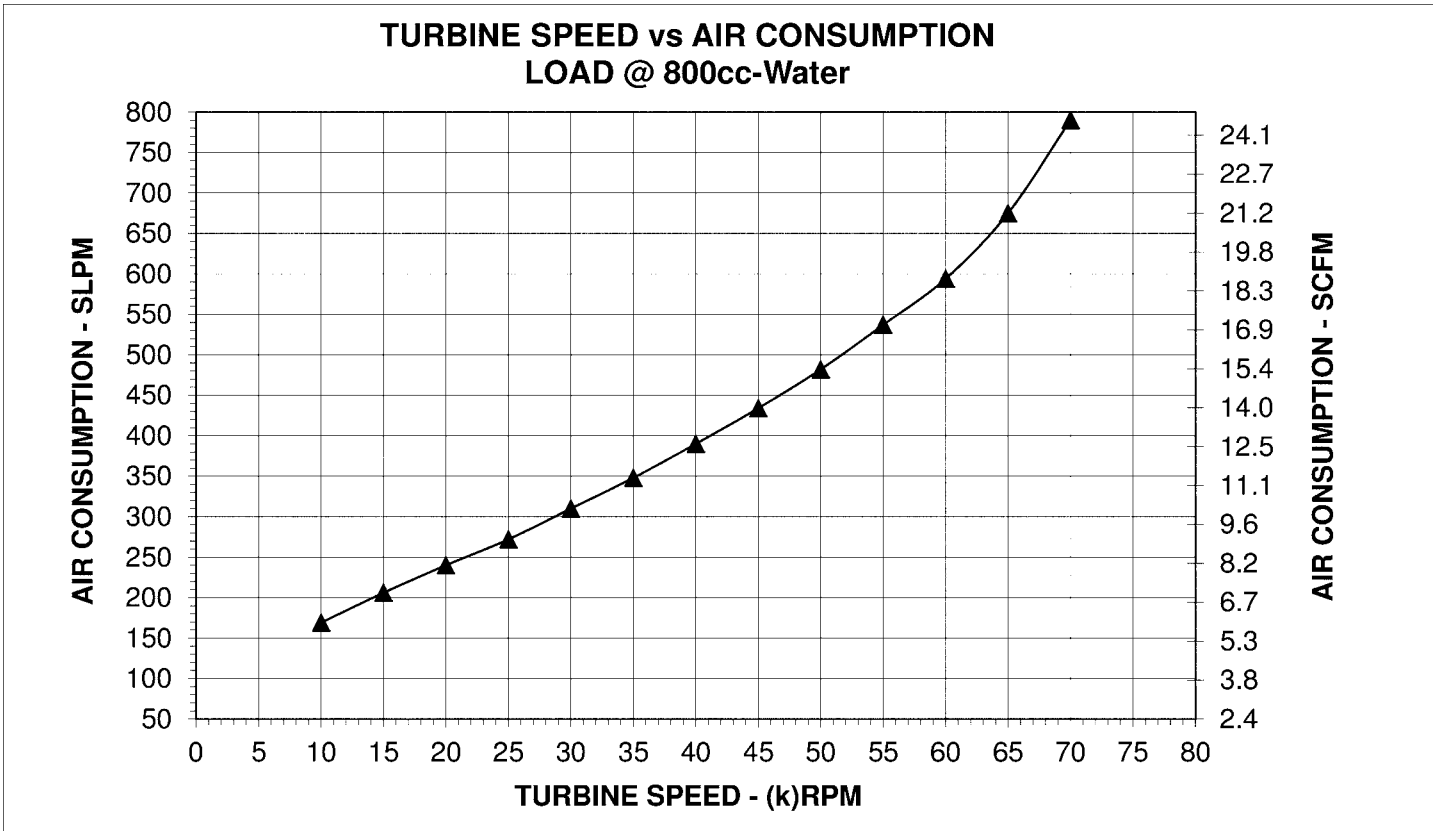

BEARING AIR FLOW RATE VS. SUPPLY PRESSURE

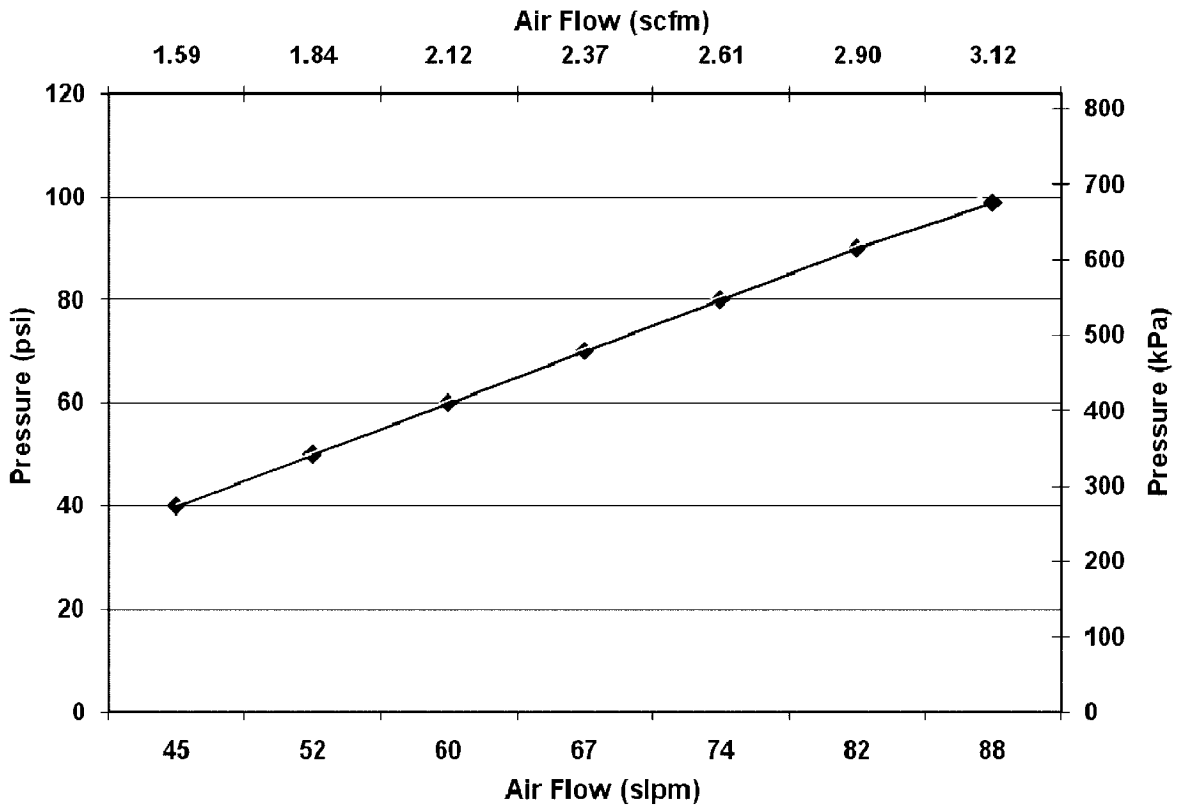

**FLOW VS. PRESSURE
MONO FLEX SHAPE AIR - SINGLE SUPPLY SOURCE
A13858-01, A12874-06/-07/-08 SHAPING AIR KIT**

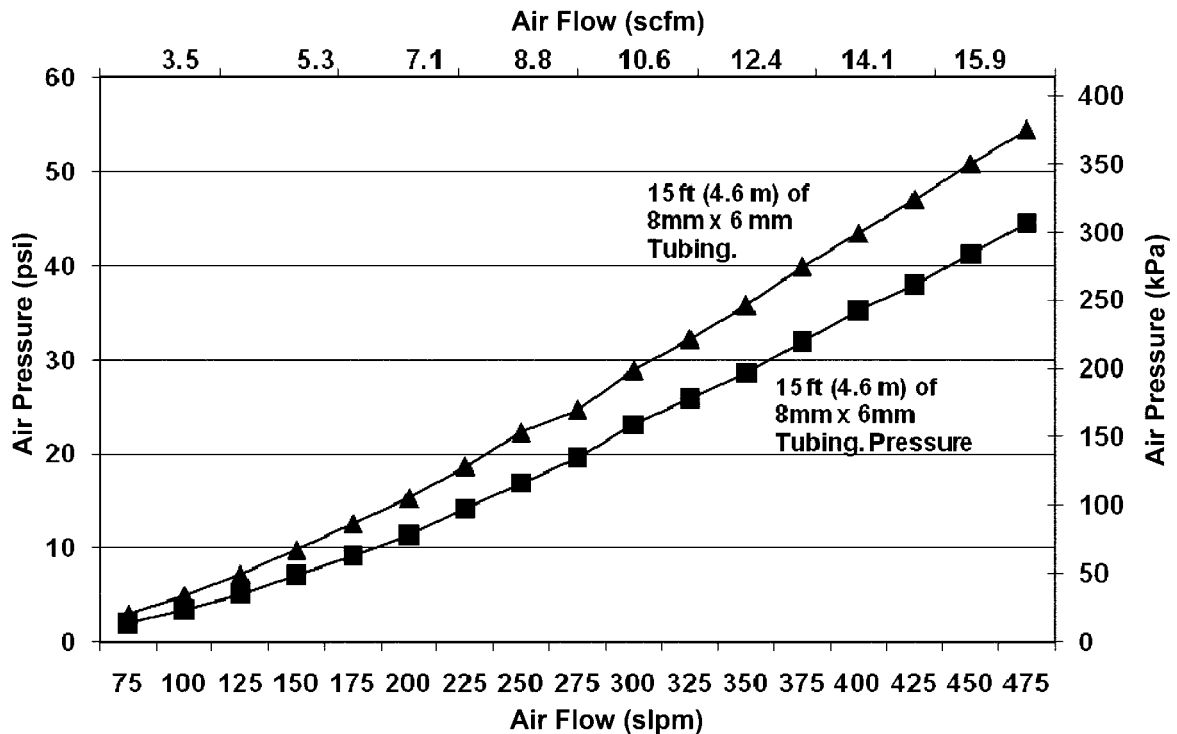

**FLOW VS. PRESSURE
MONO FLEX SHAPE AIR - DUAL SUPPLY SOURCE
A13858-01, A12874-06/07/08 SHAPING AIR KIT**

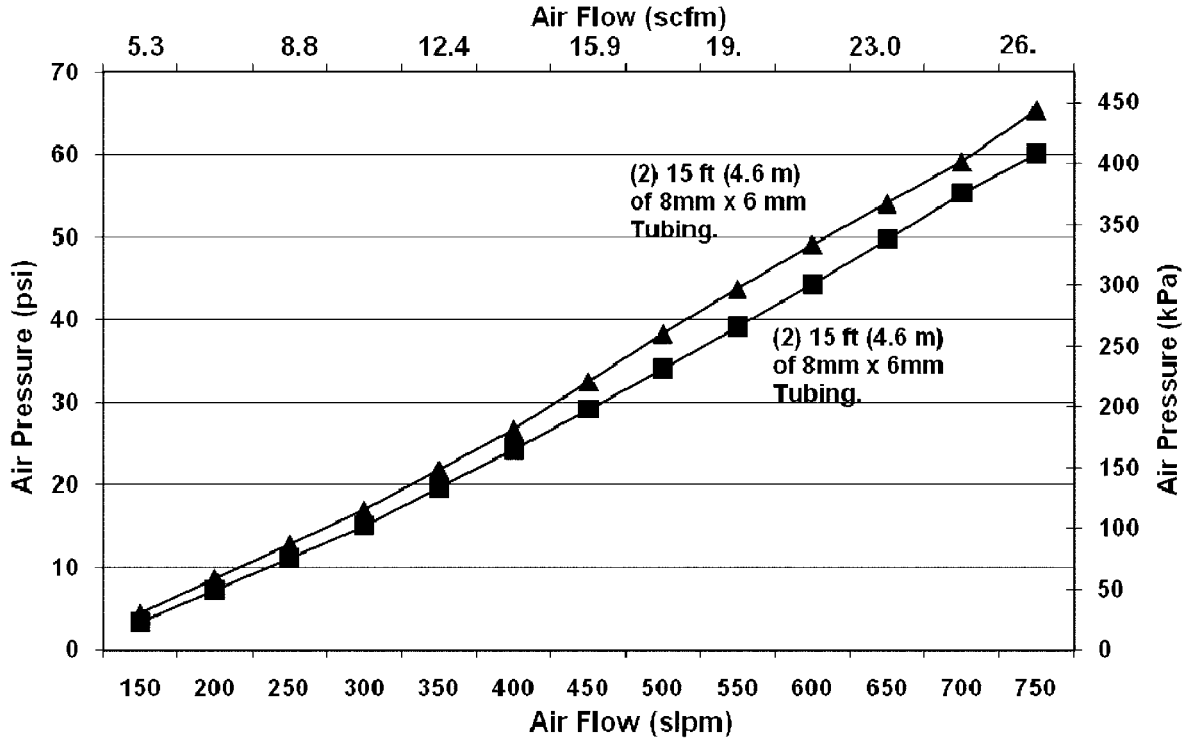

**RMA-570 DUAL FLEX AIR
A13858-02, A12874-08/-09/-10/-11 SERIES SHAPE AIR
FLOW VS. PRESSURE**

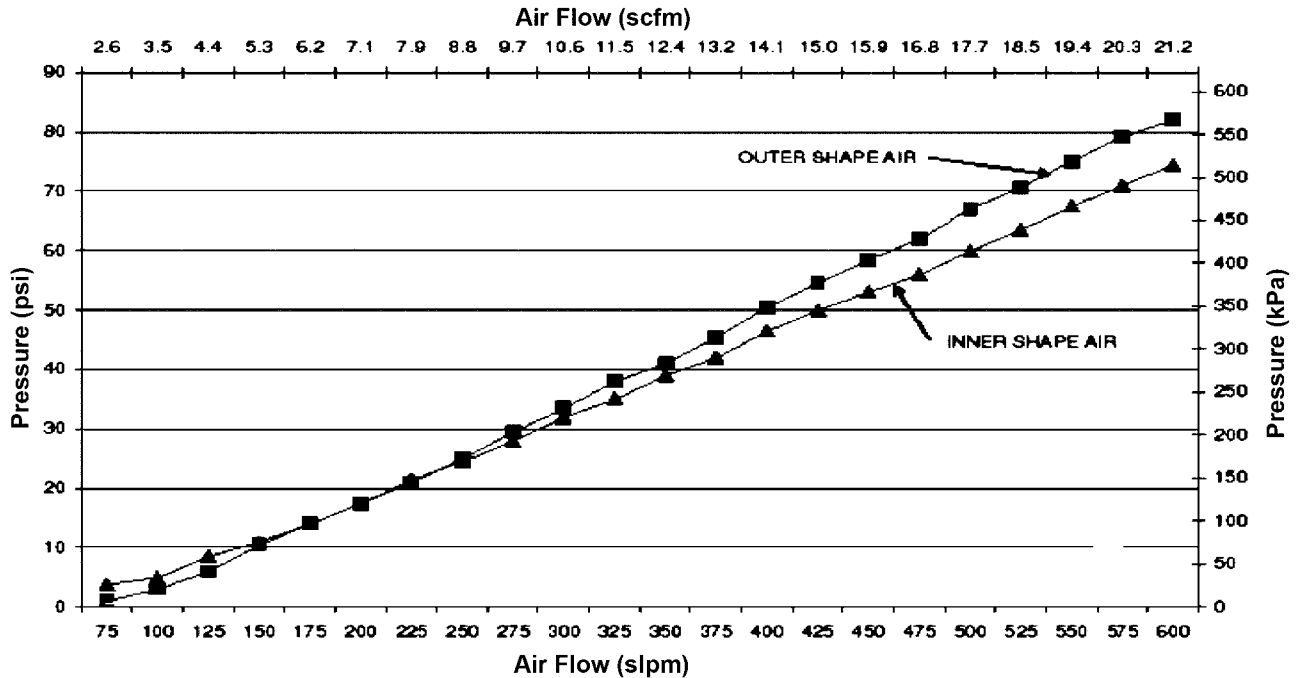

A12874-12, 13 55MM DUAL FLEX AIR PRESSURE VS. AIR CONSUMPTION

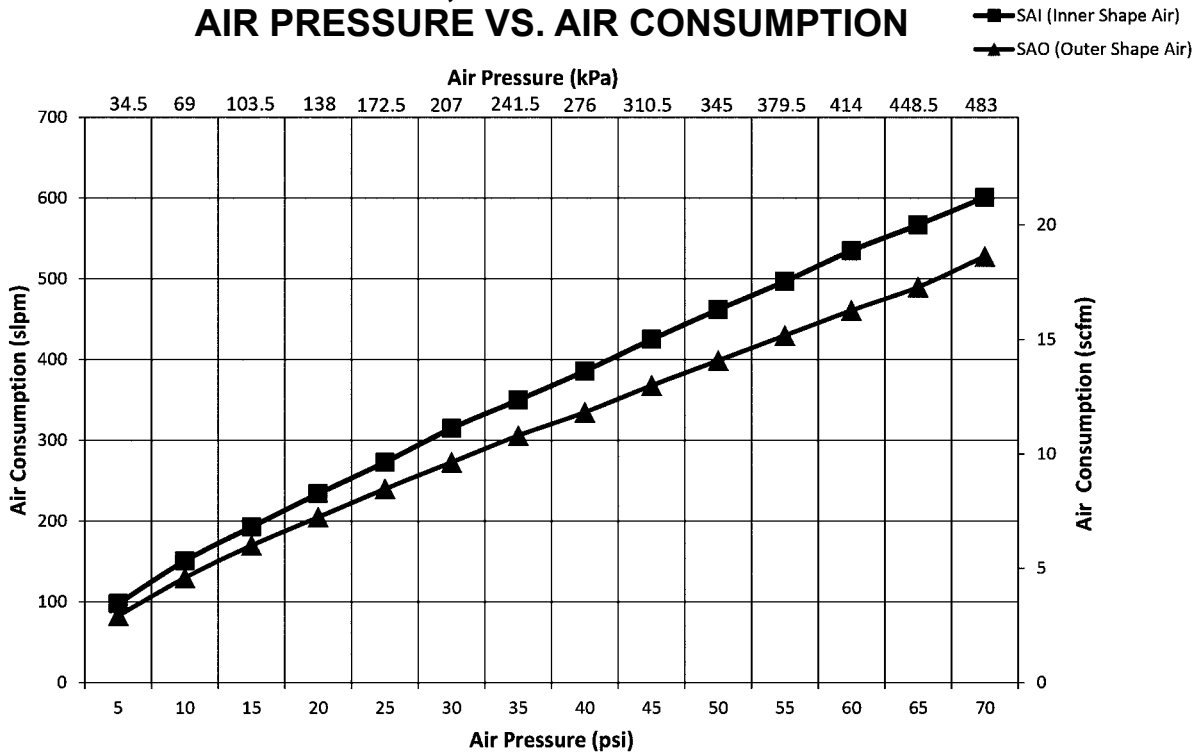

MAXIMUM FLOW RATE BY TIP SIZE, HOSE LENGTH, AND MATERIAL VISCOSITY

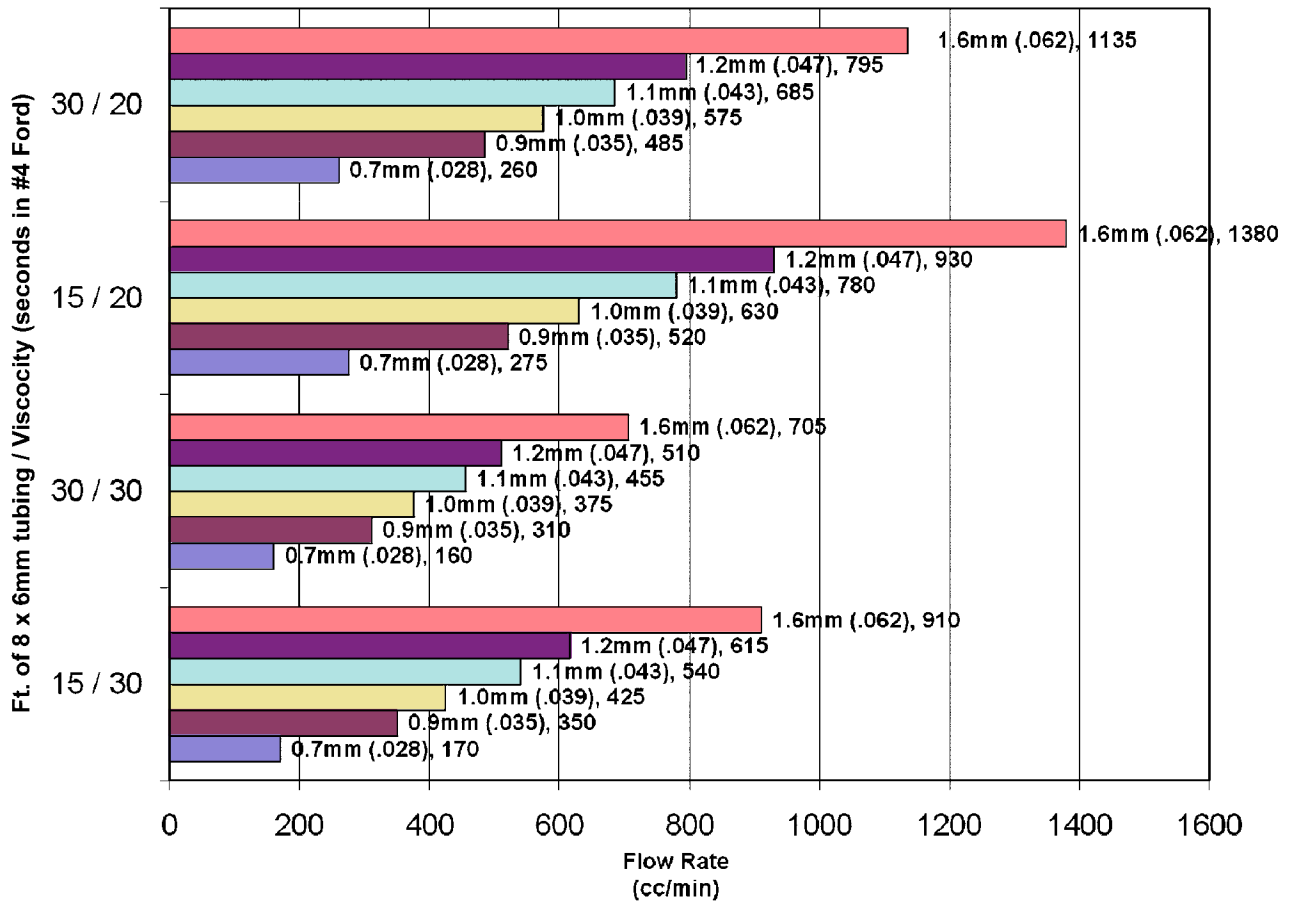

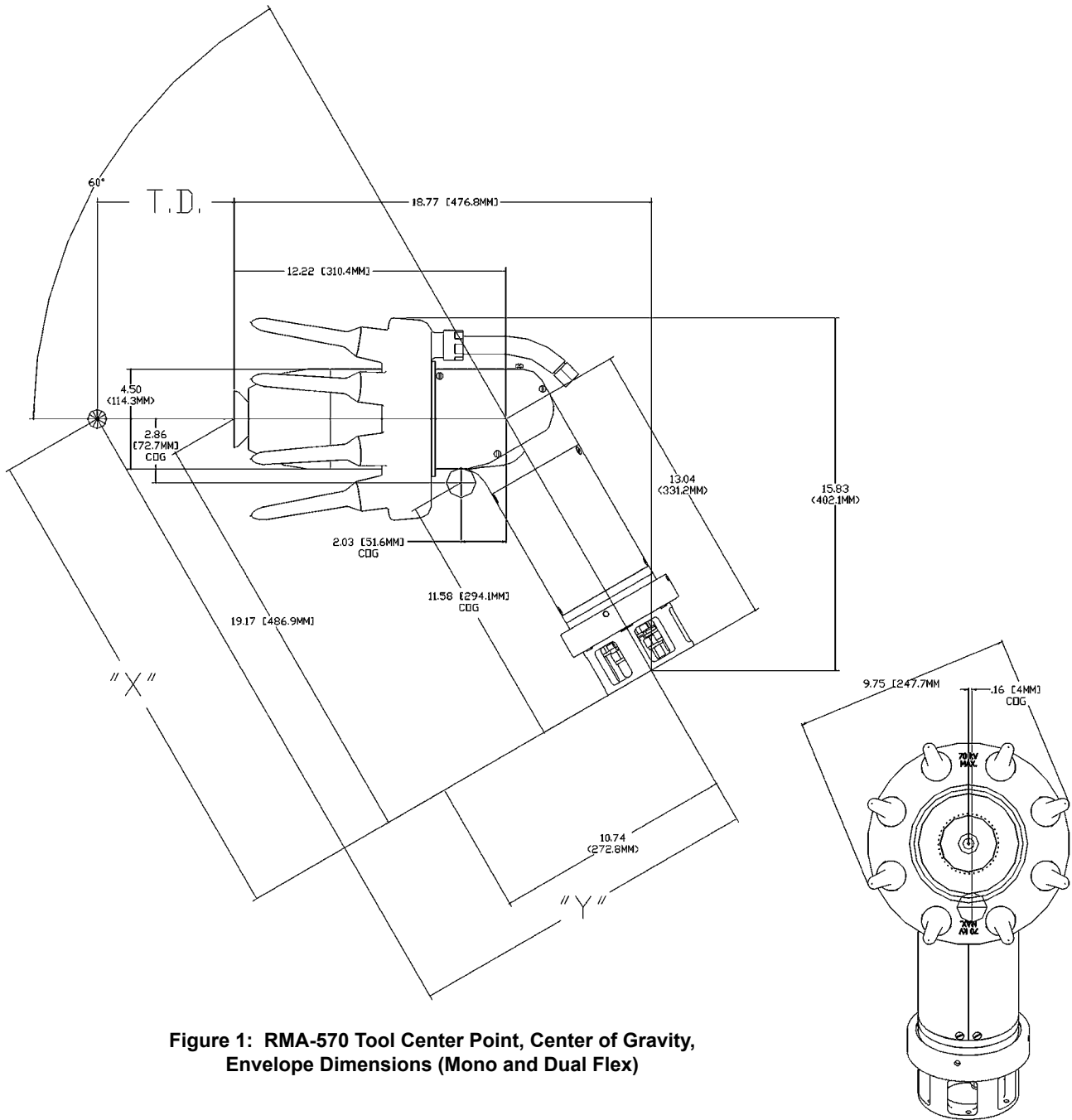
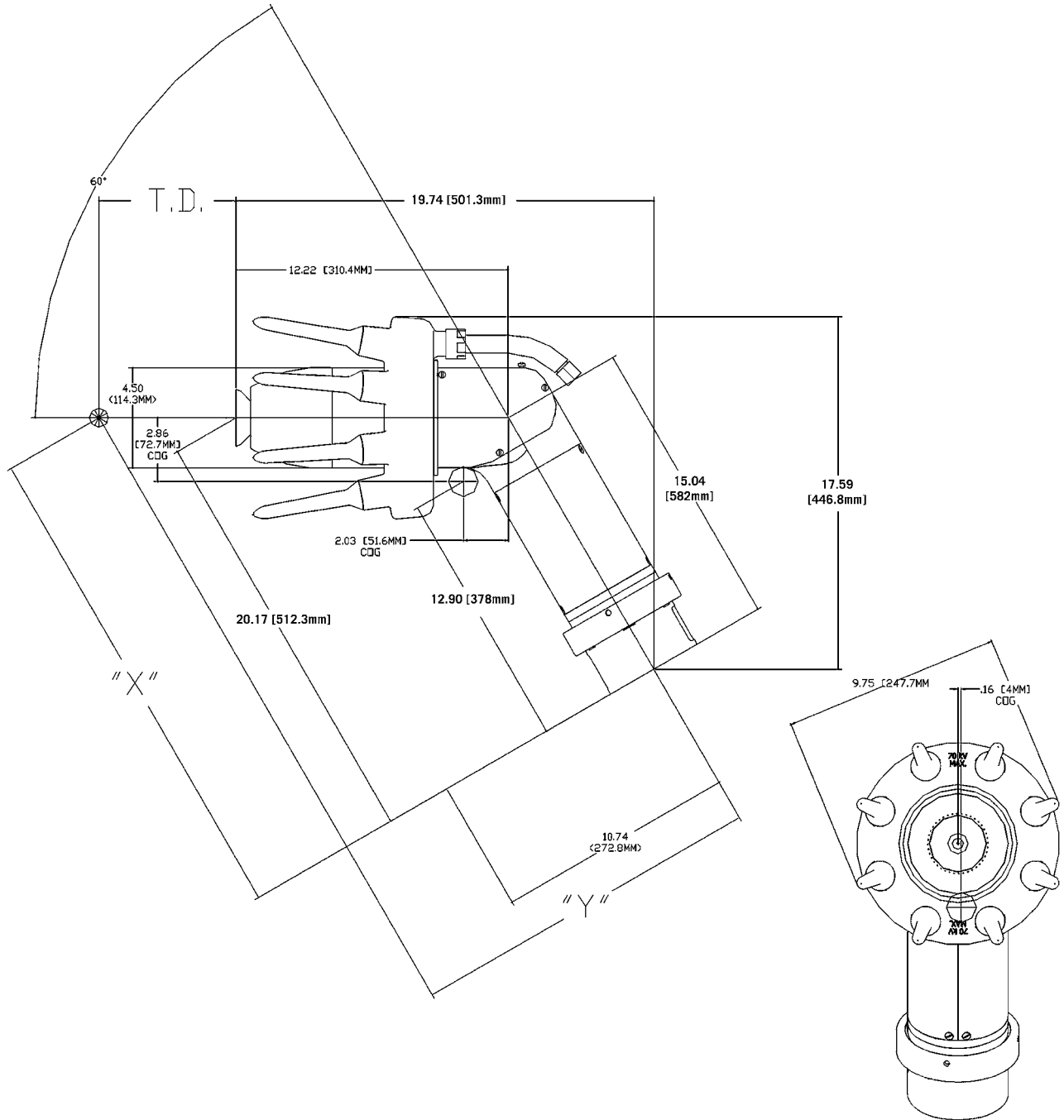

Figure 1: RMA-570 Tool Center Point, Center of Gravity, Envelope Dimensions (Mono and Dual Flex)

55 AND 65MM RMA-570 INDIRECT TOOL POINT DIMENSIONS (DUAL FLEX)		
TD	X	Y
6-Inches (152mm)	22.16-Inches (563.0mm)	15.81-Inches (401.5mm)
8-Inches (203mm)	23.16-Inches (588.4mm)	17.54-Inches (445.5mm)
10-Inches (254mm)	24.16-Inches (613.8mm)	19.27-Inches (489.4mm)
12-Inches (305mm)	25.16-Inches (663.9mm)	21.00-Inches (533.4mm)



55 AND 65MM RMA-570 INDIRECT TOOL POINT DIMENSIONS WITH LONG ADAPTER (DUAL FLEX)

TD	X	Y
6-Inches (152mm)	24.15-Inches (613.8mm)	15.81-Inches (401.5mm)
8-Inches (203mm)	25.15-Inches (639mm)	17.54-Inches (445.5mm)
10-Inches (254mm)	26.15-Inches (664.4mm)	19.27-Inches (489.4mm)
12-Inches (305mm)	27.15-Inches (689.9mm)	21.00-Inches (533.4mm)

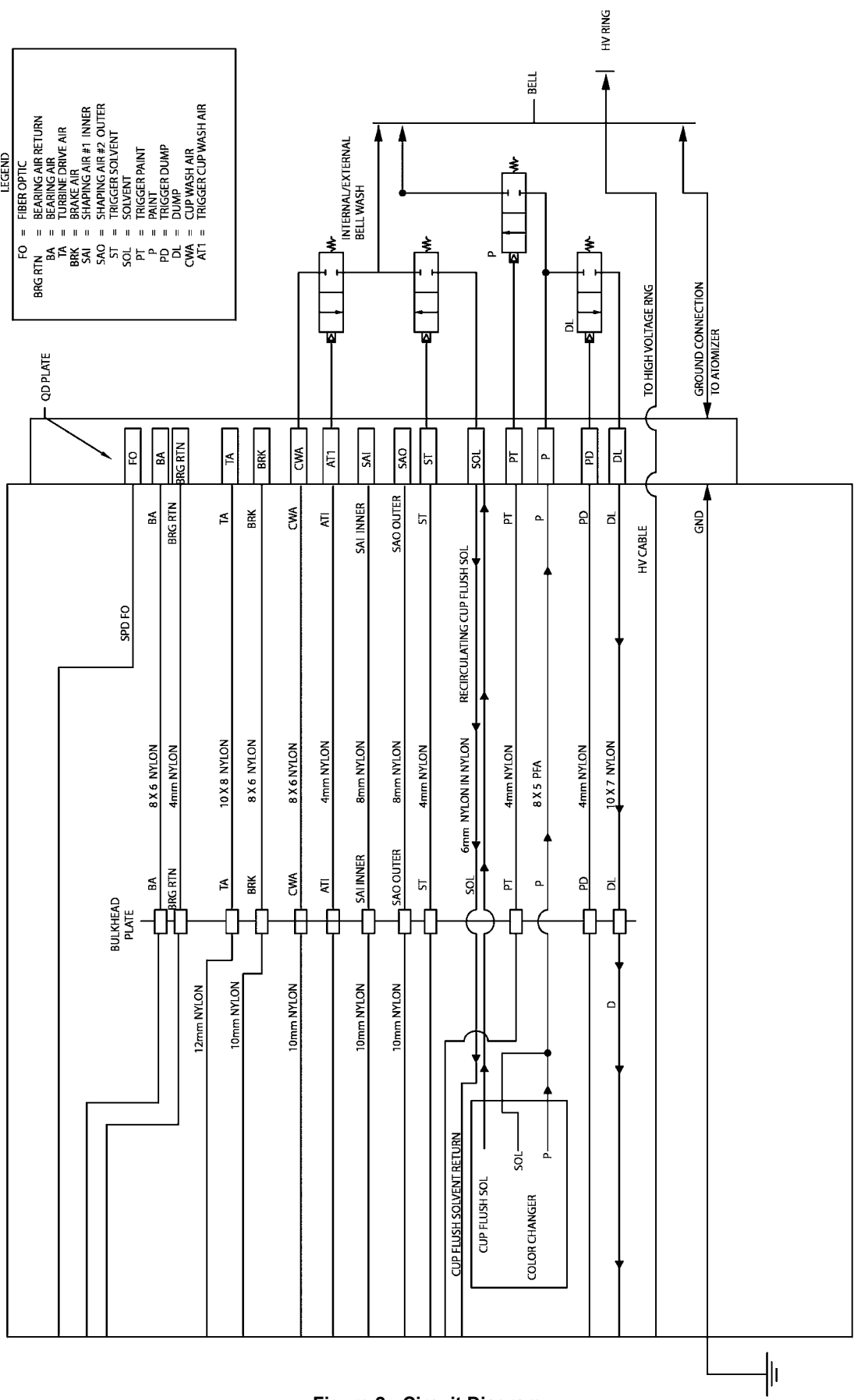

Figure 2: Circuit Diagram

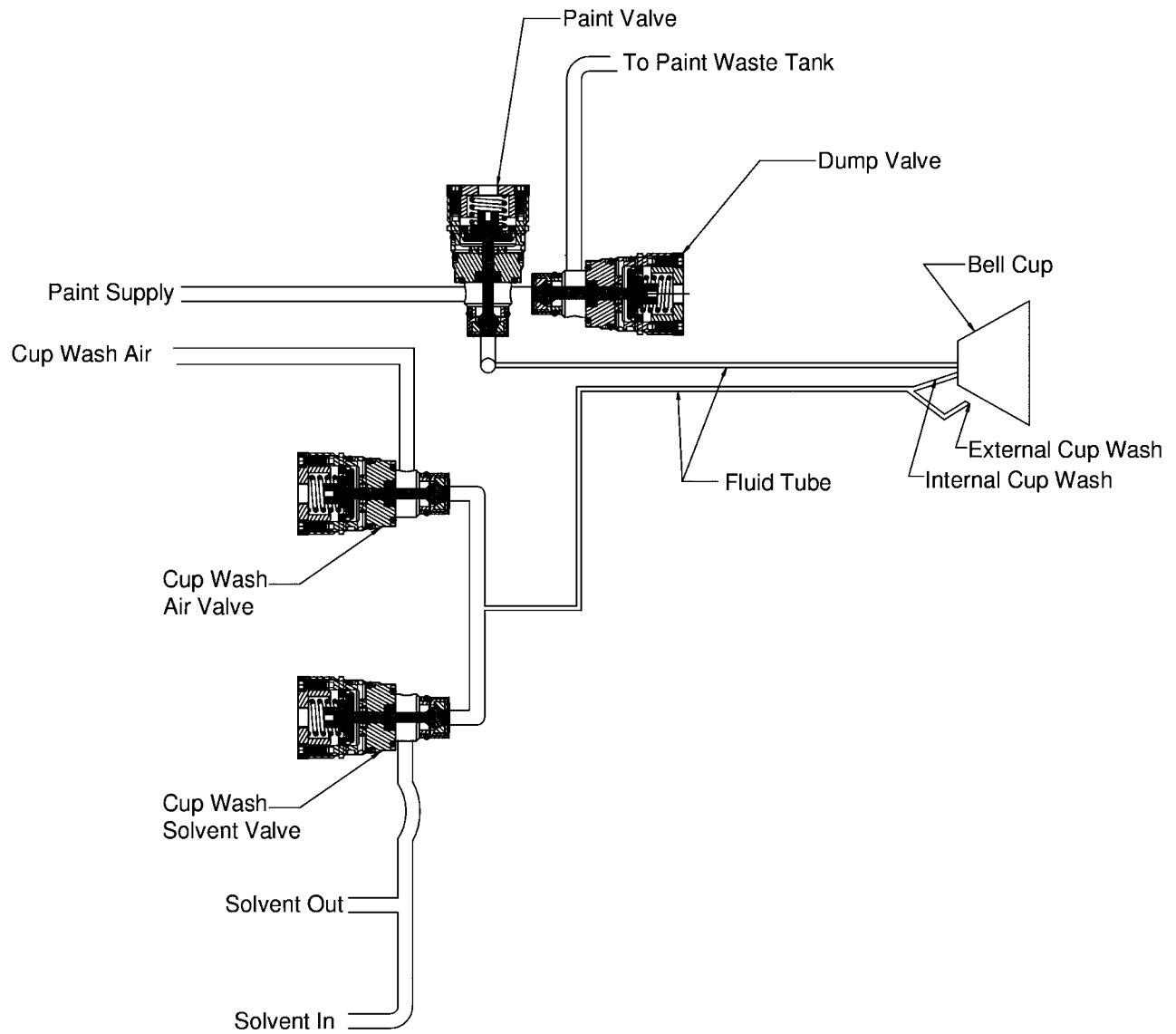

Figure 3: Valve Schematic

INSTALLATION

AIR FILTER INSTALLATION

The following air filter installation guidelines are essential for optimum performance:

1. Use 25mm OD (1-Inch OD) minimum inbound main air line.
2. Use only recommended pre-filters and bearing air filters as shown in "Air filtration Requirements" chart in the "Installation" section. Additional system air filtration (i.e., refrigerated air dryer) may also be used if desired.
3. Mount all the air filters as close as possible to the RMA-570 applicator. (DO NOT mount further than 30-Feet (9.1 meters) away.)
4. DO NOT use tape, pipe dope, or other thread sealant downstream of the bearing air filter. Loose flakes of tape or other sealant can break loose and plug the very fine air holes in the turbine air bearings.
5. Air heaters are highly recommended for use in the system to minimize the effect of excessively humid conditions and maintain turbine load capabilities. If the heated air will exceed 120°F (48.9°C), the heater must be located after all filters to prevent damage to the filter media.

NOTE

- Each applicator must have its own filter for bearing air. Recommended: RPM-418 or equivalent.

With the exception of fluid, dump, and bearing air, all other pilot and air supply lines should be bulk-headed and their diameters increased one size. For example: Turbine air should be increased to 12mm OD from bulkhead plate to the volume booster or heater outlet.

Volume Booster Recommendation (Turbine Air): (For use with A11065-05 Air Heater or Non-Air Heater System)

Ransburg Part # A11111-00

- Pilot Operated Regulator Non-Bleed Pilot
- SCFM-200
- Supply - 300 P.S.I.
- Temperature Range: 40° - 120° F

TUBE SIZE / AIR PRESSURE REQUIREMENTS

	Tube Size	Air Pressure Requirements
Bearing Air Supply (BRG)	6 X 8mm	90 psi +/- 10 kPa (621 +/- 69 kPa)
Bearing Air Return (BRG RTN)	4mm (5/32")	80 psi +/- 20 (at atomizer card) (552 +/- 138 kPa)
Turbine Air (T.A.)	8 X 10mm	Variable
Pattern Control Air #2 (SAO)	6 X 8mm	Variable
Pattern Control Air #1 (SAI)	6 X 8mm	Variable
Brake Air (BRK)	6 X 8mm	60-100 psi (414-689 kPa)
Paint Valve Control (PT)	4mm (5/32")	80 psi +/- 10 (552 +/- 70 kPa)
Dump Valve Control (PD)	4mm (5/32")	80 psi +/- 10 (352 +/- 70 kPa)
Cup Wash Solvent Valve Control (ST)	4mm (5/32")	80 psi +/- 10 (352 +/- 70 kPa)
Cup Wash Air Valve Control (ATI)	4mm (5/32")	80 psi +/- 10 (352 +/- 70 kPa)
Cup Wash Air (CWA)	6 x 8mm	80-100 psi (552-689 kPa)

EQUIPMENT GROUNDING / SAFETY RECOMMENDATIONS

In electrostatic coating systems, the flow of high voltage power from the power supply to the atomizer is insulated from ground and isolated from all other functions equipment. When the voltage reaches the atomizer, it is transferred to the coating material where, by introducing a negative charge, it causes the atomized fluid to seek the nearest positive ground. In a properly constructed and operated system, that ground will be the target object.

The directed conduction of the electric charge, through its array of wires, cables, and equipment, is accompanied by a variety of stray electrical charges passing through the air by various means such as: air ionization, charged particles in the air and radiated energy. Such charges may be attracted to any conductive material in the spray area. If the conductive material does not provide a safe drain to electrical ground, which will allow the charge to dissipate as fast as it accumulates, it may store the charge. When its electrical storage limit is reached, or when it is breached by external circumstances (such as the approach of a grounded object or person, or one at lower potential), it may discharge its stored charge to the nearest ground. If there is no safe path to ground (such as a ground wire or braided cable) it may discharge through the air as a spark. A spark may ignite the flammable atmosphere of a spray area. The hazard area extends from the point of origin up to as much as a twenty-foot radius. (See the NFPA-33 for definition and limitations of a hazard area.)

It is simple, but vital matter to be sure that all conductive objects within the spray area are grounded. All cabinets, housing, bases, supports, and stands, which are not by design, insulated from ground, be connected directly and **INDIVIDUALLY** to earth ground. ***Resting on a concrete floor or being attached to a building column may not always be sufficient ground.***

In order to provide the best ground connection possible, always attach a ground wire or insulated braided cable the terminal indicated by the ground

symbol and then to a proven ground. Always check ground connections for integrity. Some items, such as rotators and paint stands, may be supported on an insulator, but all components of the system up to the insulator **MUST** be grounded.

NOTE

- Ransburg recommends that ground connections to earth ground be 3/4" insulated copper braided wire. Grounds between assemblies within a machine should be run to a central point within the machine using #18 insulated stranded copper wire minimum. All connections should be mechanically sound and have less than 5 ohms of resistance between assemblies and the common point. The resistance between the central point and earth ground should be less than 5 ohms as well.

Where items are mounted directly on structural components such as building columns, the ground connection **MUST** still be made. In many cases the structural component may be painted or coated with an insulated material and in all cases, the equipment will provide the necessary connection at one end, but the user must be sure that the other end is secured to an earth ground. This may be achieved by the use of a standard ground clamp (properly secured), by brazing or by piercing the structural component enough to assure connection. All ground connections should be made to the most conductive metallic structural ground available.

To be sure that everything is properly grounded, the following steps should be undertaken at least daily:

1. Inspect all ground wires. Look for good, firm joints at all points of connection. Look for breaks in the ground wire. Repair all defects **IMMEDIATELY!**
2. Inspect the floor or grates for excessive accumulation of dried coating material or other residue. If there is any, remove it!

SAFE GROUNDING IS A MATTER OF PROPER EQUIPMENT MAINTENANCE AND INSTALLATION, CORRECT OPERATION AND GOOD HOUSEKEEPING. Daily inspection of grounding apparatus and conditions, however, will help prevent hazards that are caused by normal operations.

BE SURE THAT:

1. All objects in the spray area are grounded.
2. Personnel in the spray area are properly grounded. (Conductive safety shoes and coveralls.)
3. That the target object is properly grounded (less than 1 megohm resistance).
4. That the high voltage is off except during normal application.
5. That the high voltage is off and applicators are grounded during maintenance operations.
6. The spray area is kept free of accumulated coating deposits.
7. All combustible liquids in the spray area (outside of automatic delivery systems) are kept to minimum and are kept in fire safe, grounded containers. (See NFPA-30 and chapter 6 of NFPA-33.)
8. Proper ventilation is provided.
9. Personnel must thoroughly understand the equipment, its operation and maintenance, and all safety precautions.

AIR HEATER REQUIREMENTS

Turbine drive air expands as it moves through the turbine wheel cavity and as it exits the turbine from the exhaust port. This expansion will cause cooling of the exhaust air and the surfaces it contacts. This same expansion cooling can occur across the shaping air exit ports. This cooling effect can cause surface temperatures to fall below the dew point of the booth, which will result in condensation on the

interior and exterior of the atomizer, machine, and its components. It is even possible that the temperature of the supply air may be below the booth dew point, even without additional expansion cooling.

Condensation is especially probable in waterborne applications when booth temperature and relative humidity levels are typically maintained very high. This condensation will allow sufficient conductivity of the surfaces such that they act as an erratic ground source potential. This can cause damage to the equipment.

It is therefore, a requirement that turbine exhaust air temperature be maintained above the booth dew point to prevent condensation from forming on atomizer surfaces. Doing so will eliminate moisture as a potential defect in painted surfaces as well as extending equipment life. Thus, it is recommended that air heaters be installed into the atomizer air supply lines, i.e. turbine drive air, shaping air, and seal air. The air heaters must be of sufficient capacity, capable of raising the incoming air temperature at least 40°F (4.4°C) at a flow rate of 60 SCFM per applicator.

The actual air heater process setting depends on applicator fluid flow rate load, booth conditions, turbine airflow settings, and incoming air temperature. The heater should be set as low as possible, sufficient to maintain the applicator surface temperatures above the dew point in the booth.

Example: With the incoming air temperature at 72°F (22.2°C), and RMA-560 with 65mm bell cup rotating unloaded at 60 krpm has a turbine outlet temperature drop of approximately 28°F (-2.2°C) @ 40 krpm unloaded, $\Delta \sim 14^\circ\text{F}$ (-10°C). Referring to the ASHRAE Psychrometric chart, the saturation temperature range (dew point) of a spray booth maintained at 70-75°F/65-70% RH is 62-68°F (21.1-23.9°C/65-70% RH is 16.7-20°C). Thus it is almost certain that the surface temperatures of the applicator will fall below the dew point of the booth, and an air heater will be needed in this case.

To prevent condensation, a Ransburg air heater assembly should be assembled after the air filters and volume booster. (See heater and filtration options later in this manual).

AIR HEATER AND FILTRATION OPTIONS

NOTE

- Failure to use an air heater may cause damage to equipment or ruin the finished component being processed.

NOTE

- If using the A11065-05 Air Heater, air filters equivalent to HAF-503, HAF-508 and RPM-418 must be used. (See descriptions in this manual).

NOTE

- Connect air heater to turbine air tubing.

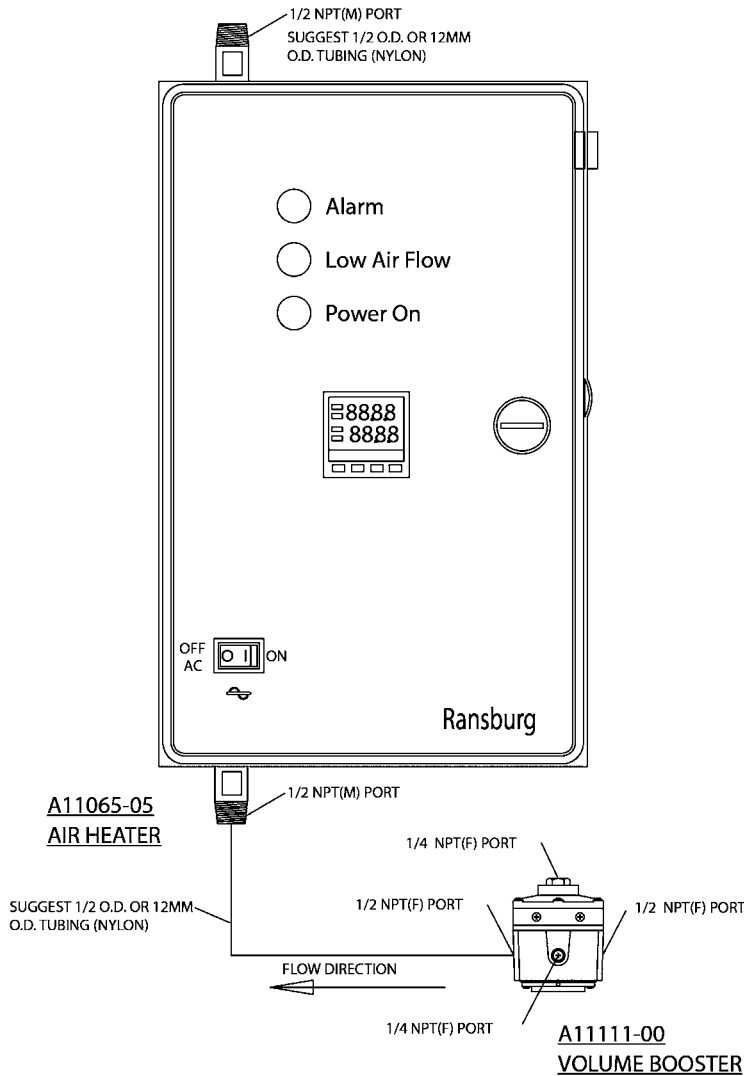

A11065-05 Air Heater

A13230-XX AIR HEATER AND FILTER COMBINATION

This combination includes filtration for turbine as well as bearing air.

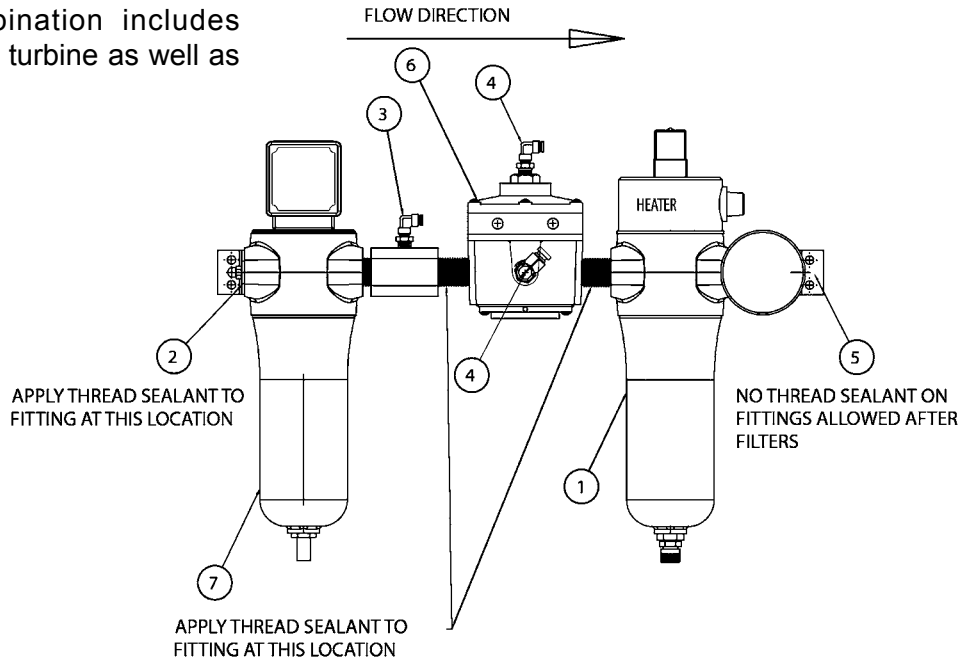

FILTER & HEATER ASSEMBLY A13230-XX					
Dash No.	Description	"A"	"B"	"C"	"E"
A13230-01	115 V.@ 13A METRIC FITTINGS	A13434-01	A13426-00	A13429-00	A13726-00
A13230-02	230 V.@ 6.5A METRIC FITTINGS	A13434-02	A13426-00	A13429-00	A13726-00
A13230-03	115 V.@ 13A FRACTIONAL FITTINGS	A13434-01	SSP-6439	A13428-00	A13727-00
A13230-04	230 V.@6.5A FRACTIONAL FITTINGS	A13434-02	SSP-6439	A13428-00	A13727-00

A13230-XX AIR HEATER AND FILTER COMBINATION			
Item	Part #	Description	Qty.
1	"A"	AIR BLOCK, NIPPLES & AIR HEATER	1
2	A13427-00	INLET FITTING, 3/8 NPS(M) X 1/2 NPT(M)	1
3	"B"	BEARING AIR FEED, SWIVEL ELBOW 1/4 O.D.TUBE X 1/4 NPT(M)	1
		BEARING AIR FEED, 6mm O.D. TUBE X 1/4 NPT(M) STRAIGHT ADAPTER	
4	79253-02	AIR FITTING, SWIVEL ELBOW 5/32 O.D. TUBE X 1/4 NPT(M)	2
5	"C"	OUTLET FITTING, 1/2 O.D. TUBE X 1/2 NPT(M) STAINLESS STEEL	1
		OUTLET FITTING, 12mm O.D. TUBE X 1/2 NPT(M) STAINLESS STEEL	
6	"E"	VOLUME BOOSTER	1
7	A13433-00	AIR FILTER & NIPPLE INCLUDED	1
8	SI-13-07	A13230-XX SERVICE LITERATURE (PROVIDED BY OTHER)	REF.

ALL UNITS: REPLACEMENT PARTS: (SERVICE NOTE)
 HEATING ELEMENT USE: A13432-01 FOR A13230-01 AND A13230-03 (115V UNITS)
 A13432-02 FOR A13230-02 AND A13230-04 (230V UNITS)
 AIR FILTER ELEMENT USE A13232-00
 THERMOMETER USE A13431-00

AIR FILTRATION REQUIREMENTS WHEN USED WITH A11065-05 AIR HEATER OR NO AIR HEATER		
Ransburg Filter Model No.	Description / Specifications	Replacement Element Part No.
HAF-503	Pre-filter, removes coarse amounts of oil, moisture and dirt. Used upstream of HAF-508 pre-filter (used in systems with poor air quality).	HAF-15 Element One
HAF-508	Pre-filter, coalescing type, 136 SCFM, 98.5% efficiency particulate removal .3 to .6 micron, max. aerosol passed 1.0 micron, max. solid passed .4 micron (dependent upon SCFM requirement per applicator, one HAF-508 can be used with up to three applicators).	HAF-38 Elements, Carton of 4
RPM-418	Bearing air filter, coalescing type, 19 SCFM, 99.995% efficiency particulate removal .3 to .6 micron, max. passed .6 micron max. solid passed .2 micron (one per applicator)	RPM-33 Elements, Carton of 8

⚠ CAUTION

- Air must be properly filtered to ensure extended turbine life and to prevent contamination of the paint finish. Air which is not adequately filtered will foul the turbine air bearings and cause turbine failure. The correct type filters must be used in an RMA-570 system. The filter elements must be replaced regular schedule to assure clean air.
- It is the user’s responsibility to ensure clean air at all times. Turbine failure resulting from contaminated air will not be covered under warranty. If other filters are incorporated in the system, the filters to be used must have filtering capacities equal or better than those shown in “Air Filtration Requirements Charts.”
- The user must ensure the bearing air supply is not inadvertently turned off while the RMA-570 air motor is turning. This will cause air bearing failure.

NOTE

- Each applicator must have its own filter for bearing air. Recommended: RPM-418 or equivalent.

MOUNTING

The RMA-570 is equipped with a quick disconnect assembly. The quick disconnect feature consists of a robot plate which is permanently attached to the robot through a wrist adapter plate, and a mating bell plate which is a part of the RMA-570 atomizer assembly. The atomizer is secured to the robot plate with a threaded retaining ring.

ELECTRICAL AND FIBER OPTIC CONNECTIONS

The fiber optic connection is made on the back of the atomizer’s robot plate. The fiber optic cable comes preassembled with connectors that are secured in place by set screws tightened from the side of the robot plate. These set screws shall be tightened to 15-20 lbs/in (1.7-2.3 Nm). An adequate ground must be provided to the mounting plate to ensure that fluid fittings, etc. are at ground potential.

Maximum amount of splices for any length of cable is 3. The speed detection signal may be affected if splices are exceeded. Length in any combination for the fiber optic is 100-feet.

TYPICAL INSTALLATION

The “Indirect Charge Typical Installation” figures in the “Installation” section shows a typical installation of the applicator with the MicroPak.

FLUID CONNECTIONS

The paint, solvent, and dump fluid tubing are connected on the back of the robot plate with stainless steel compression fittings and PFA tubing. Fluid tubing requirements are shown in “Fluid Tubing Connection Requirements” below.

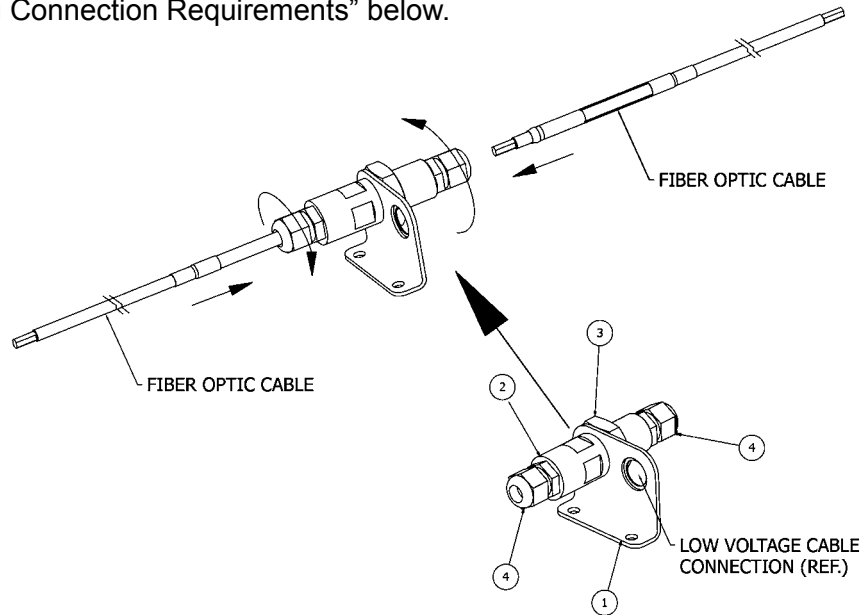

A13392-00 FIBER OPTIC/LOW VOLTAGE CONNECTOR KIT

A13392-00 FIBER OPTIC/LOW VOLTAGE CONNECTOR KIT - PARTS LIST			
Item	Qty.	Part #	Description
1	1	A13393-00	BRACKET, FIBER OPTIC/LOW VOLTAGE
2	1	A13391-00	FIBER OPTIC BULKHEAD CONNECTOR
3	1	A13537-00	HEX NUT, M22 X 1.5
4	2	80073-00	STRAIN RELIEF, CABLE GLAND

FLUID TUBING CONNECTION REQUIREMENTS		
	Fixed Atomizer	Pressure (Maximum)
Paint Line (P)	8mm X 5mm PFA	200 psi max. (1379 kPa)
Cup Wash Solvent Line (SOL)	A11283-00 Nylon Recirculation Tube-In-Tube	150 psi max. (1033 kPa)
Dump Line (DL)	10mm X 7mm Nylon	200 psi max. (1379 kPa)

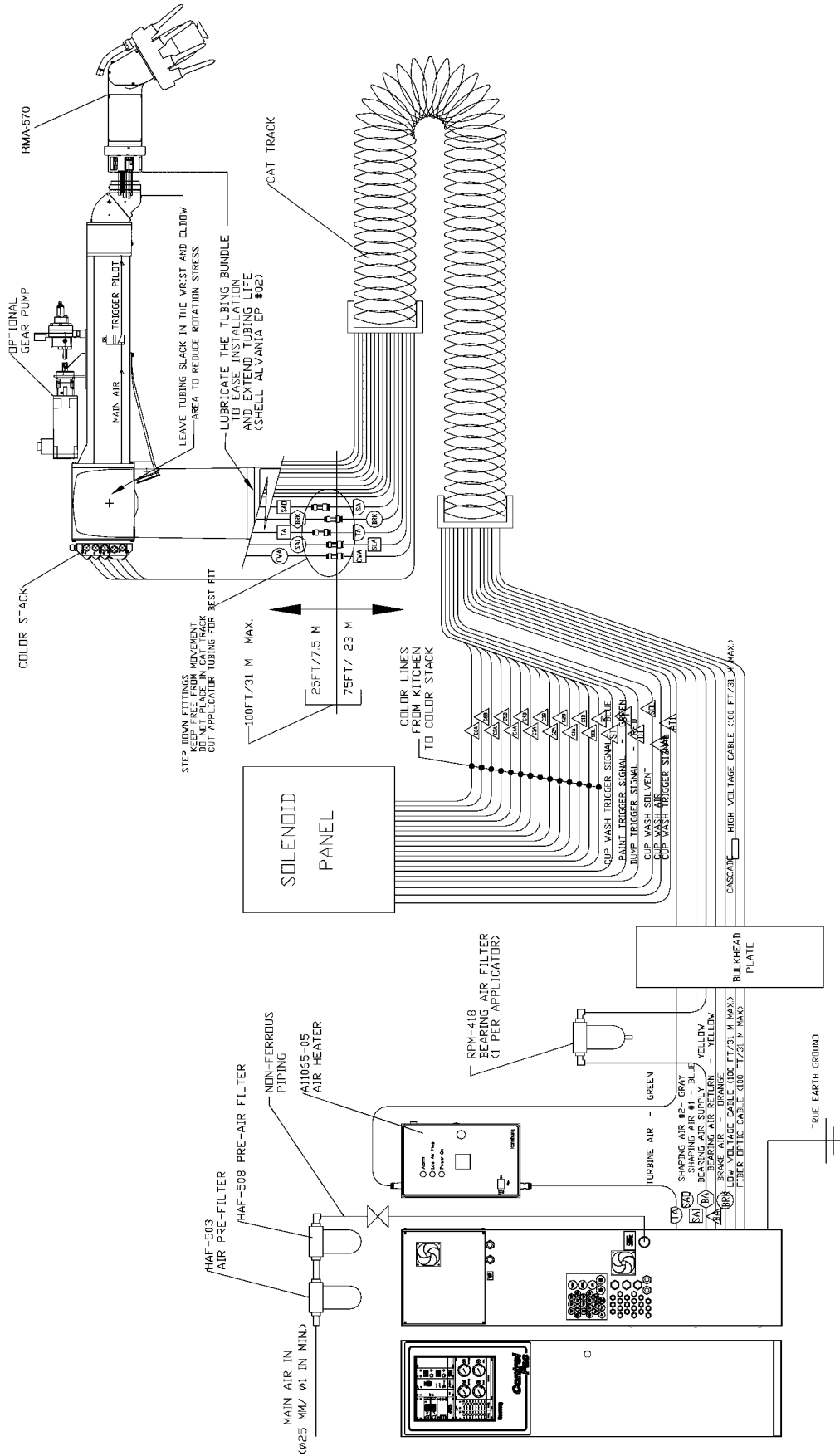

Figure 5: Typical Installation of RMA-570™

TUBING BUNDLE INSTALLATION

Typically, the tubing bundle is pulled through the robot arm from the robot wrist side. Keep the bundle taped except for the bundle that will be inside the arm. Pull the tubing through the wrist and arm, leaving about 250mm (10-inch) of tubing sticking out the front of the wrist plate (see Figure 6). Fasten the cable bundle at the exit of the arm. Push the robot spacer plate and applicator mounting plate to the robot wrist plate aligning the top dead center marks of the spacer plate and robot wrist plate. Fasten using appropriate screws. Installing the tubing bundle in this fashion will increase tubing bundle life significantly.

BUNDLE LUBRICANT

When the tubing bundle is installed, it should be lubricated with a generous amount of lubricant to increase the service life of the tubes. A recommended lubricant is Shell Alvania EP #02. There are other lubricants that are available for use. Prior to using a lubricant, insure it is silicone free, resists heat breakdown, and is compatible with the materials it will contact. It is recommended that tubing bundles be re-greased every six (6) months maximum.

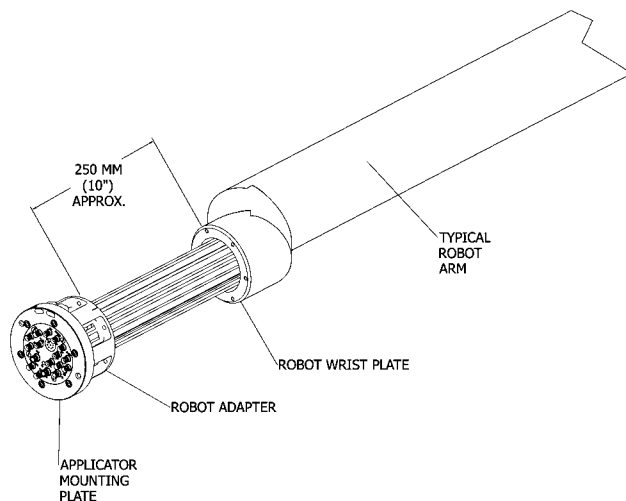

Figure 6: Tubing Bundle Installation

INTERLOCKS

The following system interlocks are required to prevent equipment damage:

1. Bearing air should remain on at all times and should be shut off only by turning off the main air to the pneumatic control cabinet.
2. It should not be possible for the coating material to be sprayed unless the turbine is spinning.

▲ WARNING

- When the turbine air is turned off, the turbine will continue to operate or “coast down” for about two minutes. Provisions should be made to assure that the operator waits at least three minutes, after shutting off the turbine air and before shutting off the main air supply.
- The bell cup must be removed when making flow checks. If the paint is turned on when the bell is mounted and the turbine shaft is not rotating, paint will enter the shaft and possibly damage the air bearing. Material flow checks (flow rate verification) must be made with the bell cup off and the turbine not rotating. Normally pneumatic interlocks will not allow the paint to trigger on when the turbine air is off.
- The high voltage and/or coating material must never be turned on unless the bell cup is mounted on the motor shaft and the turbine is rotating.
- Pneumatic input to the turbine air inlet must be controlled to prevent the turbine from exceeding the maximum rated speed of 100,000 rpm. (See “Specifications” in the “Introduction” section.)
- High voltage must never be turned on while cleaning solvent is being sprayed either through the applicator supply or the cup wash line. High voltage and both solvent triggers must be interlocked (direct charge only).

3. Two Interconnected bearing air ports are provided, one for supply air and the other to be used as a return signal for measuring bearing air pressure at the atomizer. If bearing air falls below 80 psi (551.6 kPa) at the atomizer, the turbine air should be automatically interlocked to shut off. This interlock is provided by the Serial Atomizer Module, (See current "Serial Atomizer" manual) or thru the MicroPak 2e Single Bell Controller.
4. High voltage must be interlocked with the solvent valve pilot signal to prevent solvent flow while high voltage is energized (direct charge only).
5. Turbine air and brake air must be interlocked to prevent both from being used simultaneously. This interlock is provided by the Serial Atomizer Module. (See current "Serial Atomizer" manual) or thru the MicroPak 2e Single Bell Controller.
6. Any other interlocks required by local national code or international code.

**WARNING**

- Bell cup must be rotating at least 20,000 rpm when fluid is triggered. Turning on fluid without the bell cup spinning may flood the turbine and cause damage to components.

OPERATION

⚠ WARNING

Operators must be fully trained in safe operation of electrostatic equipment. Operators must read all instructions and safety precautions prior to using this equipment (see NFPA-33).

As with any spray finishing system, operation of the RMA-570 involves properly setting the operating parameters to obtain the best finish quality for the coating material being sprayed, while maintaining correct operation and reliability of the equipment used. Adjustments to operating parameters, which cover spraying, cleaning, and on/off control, include:

- Coating Materials
- Fluid Flow Rate Control
- Fluid Valve Control
- Turbine Speed
- Bearing Air Adjustment
- Shaping Air #1 (Pattern Control)
- Shaping Air #2 (Pattern Control)
- Brake Air
- Electrostatic Voltage
- Target Distance

⚠ WARNING

Electrical discharge of a high electrical capacitance fluid/paint system can cause fire or explosion with some materials. If arcing occurs when a specific coating material is used, turn the system off and verify that the fluid is non-flammable. In these conditions the system is capable of releasing sufficient electrical and thermal energy to cause ignition of specific hazardous materials in air.

FLUID FLOW RATE CONTROL

Externally mounted fluid regulators or gear pumps are typically used to control fluid flow. Paint is supplied to the RMA-570 by way of the tubing bundle through the robot arm.

The atomizer assembly is equipped with micro valves which are pneumatically operated to direct the flow of paint to either the feed tube or dump line and to supply an intermittent solvent to clean the interior and exterior of the bell cup.

The feed tube has several sized removable tips available from .7mm - 1.6mm (.027-inch - .062-inch). The viscosity and volume of the coating material being sprayed determine the correct size of feed tube tip for each installation. (Reference "Fluid Tip Flow Rate" chart in the "Introduction" section.)

Fluid Flow Rate Check

In the test mode, the flow rate can be measured by removing the bell cup from the atomizer, turning the fluid flow on, and capturing the material in a graduated beaker or measuring cup for a fixed period of time (shaping air, high voltage, and turbine air must be off).

WARNING

➤ Danger of shock and/or personal injury can occur. Proper grounding procedures must be followed. Personnel must never work around the turbine when the turbine is spinning or when high voltage is turned on.

FLUID VALVE CONTROL (Trigger, Dump, and Solvent)

(See “Indirect and Direct Charge Circuit Diagram” in the “Introduction” section.) The fluid valves in the RMA-570 are actuated by an air signal. The air pressure must be greater than 70 psi (482.6 kPa) to assure proper actuation of the valve. Applying air to the valve actuator turns on the fluid or air for that valve.

The paint trigger valve controls the paint flow to the bell. When actuated, paint flows through the valve to the fluid tube, and into the rear of the bell cup. The bell cup must be spinning at least 20,000 rpm when fluid is turned on to enable the fluid to flow through the bell paint passage and be atomized.

The dump valve controls the paint flow through the dump line. When actuated, paint flow is directed to the dump return line. This provides a method of rapidly removing paint from the incoming line for cleaning and/or color change. Normally, the dump valve is not actuated at the same time as the paint trigger valve since the trigger valve is intended to cause the fluid to flow to the bell at the prescribed input pressure.

The solvent valve controls the flow of cup wash solvent. When actuated, solvent flows through a separate fluid tube passage and into the bell cup. This provides cleaning of the inside of the bell cup. The outside of the cup is simultaneously cleaned by a nozzle mounted on the shaping air

ring and shroud. The solvent valve should never be triggered at the same time as the paint trigger valve to prevent solvent from flowing backward into the paint line.

The cup wash air valve controls the flow of air. It is recommended that this valve and the solvent valve be controlled to create an air/solvent chop sequence for superior internal and external cup cleaning.

WARNING

➤ Never perform the interior/exterior cup clean process with high voltage on (direct charge only).

To color change the applicator, a solvent air chop must be provided through the main paint line (see “Direct and Indirect Charge Typical Installation” in the “Installation” section).

WARNING

➤ The normal fluid flow range is 25-1000 cc/min. During a color change or when flushing the system, higher flow rates may be required. However, the maximum flow rate through the bell cup must not exceed 1000 cc/min. to avoid solvent or paint from flooding into the internal portion of the air bearing motor assembly or front shroud.

TURBINE SPEED

Turbine speed is determined by the input air pressure/flow at the rear of the atomizer.

Turbine speed is intended to be closed loop controlled using the fiber optic speed transmitter, located on the turbine manifold. A speed input to a remote speed controller, such as the Serial Atomizer Module, is required, (See “Speed and Pressure” charts in the “Introduction” section.) or by the integrated speed controller in the MicroPak 2e Single Bell Controller.

NOTE

- The bell rotational speed determines the quality of atomization and can be varied for various paint flow rates and paint formulations. For optimum transfer efficiency and spray pattern control, the bell rotational speed should be set at the minimum required to achieve proper atomization. Excessive speed reduces transfer efficiency!

! WARNING

- DO NOT exceed the maximum rated operating speed and turbine inlet pressure. Excessive speed may cause air turbine damage or damage to the bell.

BEARING AIR ADJUSTMENT

The nominal bearing air pressure is 90 psi (620.5 kPa), measured at the rear of the atomizer. Minimum pressure is 80 psi (551.6 kPa) and maximum pressure is 100 psi (689.5 kPa). The turbine should never be operated with less than 80 psi (551.6 kPa) bearing air pressure.

Bearing air must be present when turning the turbine on. Bearing air must remain on when the turbine air is turned off until the turbine stops

spinning. Never turn off bearing air to cause the turbine to stop spinning. If connected, brake air can be used to slow the turbine.

! WARNING

- Bearing air **MUST** be **ON** and supplied at a minimum of 80 psig (551.6 kPa) whenever the turbine is operated. If not, severe bearing damage will occur. It is recommended that bearing air be left turned on at all times, except during maintenance or disassembly.
- Bearing damage (and subsequent turbine failure) caused by running the turbine without bearing air **WILL NOT** be covered under the Ransburg warranty.

The RMA-570 is equipped with a bearing air return line to monitor bearing air pressure at the mounting manifold. When connected to the remote Serial Atomizer speed controller, or to the MicroPak 2e Single Bell Controller, operation of the turbine will automatically be shut down whenever the bearing air pressure falls below the setting of 80 psi (551.6 kPa).

SHAPING AIR #1 MONO FLEX

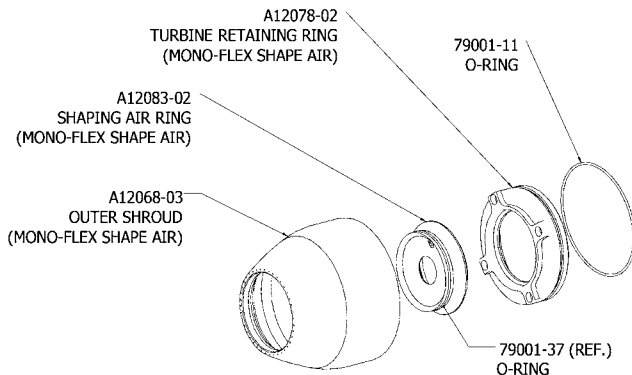

Figure 7: A12874-07 Shaping Air Kit (Mono Flex Shape Air)

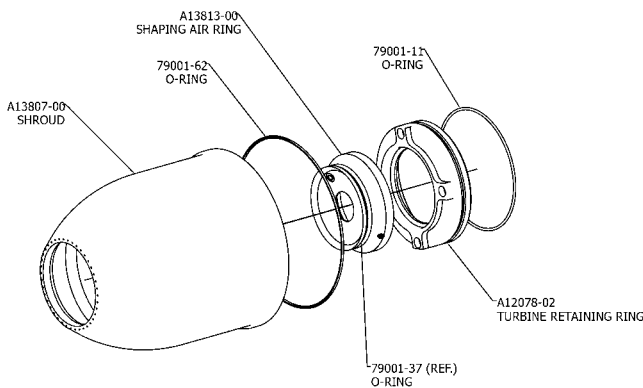

Figure 7a: A13858-01 Shape Air Kit Mono Flex (All PTFE Parts)

A12874-07 and A13858-01 Shaping Air Kit (Mono Flex Air) 65mm Bell Cups Only

As the name implies, the shaping air is supplied so that it is counter to the rotation of the bell cup. This combination will provide a pattern size from 10"- 24" (250mm 610mm) depending on air flow, fluid flow, and cup rotation speed. Connection is made using the "blue" 8mm tube labeled "SAI" on the tubing bundle. The other 8mm tube labeled "SAO" is "gray" in color and typically plugged. However, if additional air is required, this "SAO" tube can be connected to a secondary controlled

air source. Precautions must be taken that one does not have a significantly higher pressure than the other to avoid any feed back flow. This shaping air combination can be used with any 65mm bell cup (See "Pressure and Flow Data Charts" in the "Introduction" section).

Sample Mono Flex Shape Air Configurations:

Patterns sizes based on waterborne basecoat paint, target distance: 230mm (9 inches), 70kV electrostatics applied (Results will vary depending on fluid rate, material viscosity, target distance and with electrostatics applied) Typical pattern size achievable with this shaping air configuration is 230mm-860mm (9 - 34 inches).

MONO FLEX SHAPE AIR PATTERN			
Turbine Speed (krpm)	Inner Shape Air (slpm)	Fluid Flow (cc/min)	Pattern Size (mm/inches)
50	120	100	457/18
60	120	200	660/26
70	120	300	737/29
70	120	400	864/34
60	350	200	279/11
70	350	300	381/15
70	350	400	482/19
60	525	300	228/9
70	525	400	10.5

NOTE

- A minimum of 70 slpm (2.6 SCFM) should always be kept flowing in the shaping air passage to keep the face of the applicator clean during manual cleaning breaks.

SHAPING AIR #2 DUAL FLEX

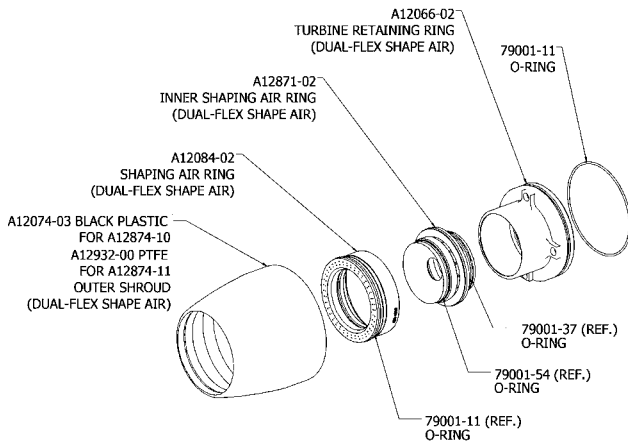

Figure 8: A12874-10/11 Shaping Air Kit (Dual Flex Shape Air)

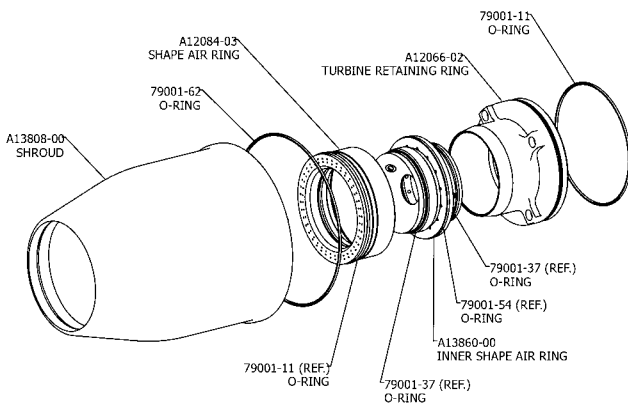

Figure 8a: A13858-02 Shaping Air Kit Dual Flex (All PTFE Parts)

A12874-10/11 Dual Flex Shaping Air Kit (For 65mm Bell Cups)

As the name implies, both shaping air outlets supply air that is counter to the rotation of the bell cup. This combination will provide a pattern size from 3" - 10" (76mm - 254mm) depending on bell rotation speed, fluid flow, and air flow. Each set of shaping air holes are independently controlled. The inner set of holes are supplied by connecting the "blue" tube labeled "SAI" on the tubing bundle to a regulated air source. The outer set of shaping air

holes are supplied by connecting the "gray" tube labeled "SAO" on the tubing bundle to a regulated source. The air supplies work in combination with each other to provide desired results. This combination of shaping air can be used with any 65mm bell cup.

Sample Dual Flex Shape Air Configurations

Pattern sizes based on solvent borne metallic paint with a viscosity of 30-32 centipoise, target distance: 175mm (7 inches), no electrostatics applied (Results will vary depending on fluid flow rate, material viscosity, target distance and with electrostatics applied) Typical pattern size achievable with this shaping air configuration is 75mm-300mm (3-12 inches).

DUAL FLEX SHAPE AIR PATTERN				
Turbine Speed (krpm)	Inner Shape Air (slpm)	Outer Shape Air (slpm)	Fluid Flow (cc/min)	Pattern Size (mm/inches)
60	550	0	100	75/3
50	550	0	100	114/4.5
60	500	150	100	89/3.5
50	500	150	100	121/4.75
60	75	500	200	203/8
50	75	500	200	248/9.75
40	0	500	200	254/10

As per the chart above, as the outer shape air is increased, the pattern increases. It should also be noted that when the turbine speed is increased, the pattern size will decrease. By varying combinations, patterns between 75mm and 254mm can be achieved.

SHAPING AIR #3 DUAL FLEX

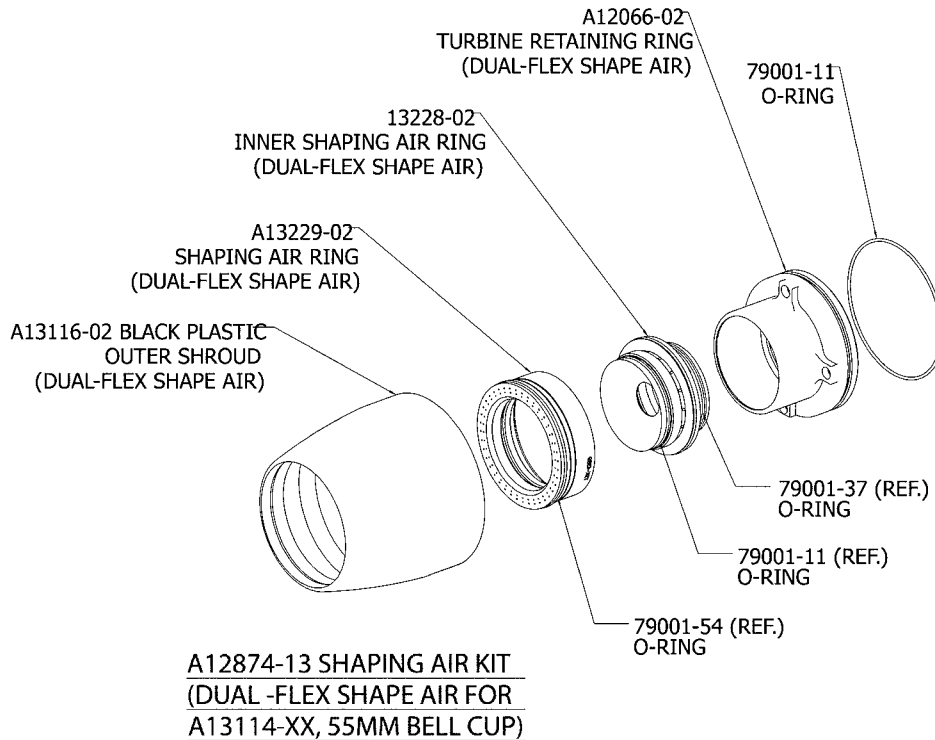

A12874-13 Dual Flex Shaping Air Kits 55mm Bell Cups

As the name implies, both shaping air outlets supply air that is counter to the rotation of the bell cup. Both sets of shaping air holes are independently controlled. The inner set of holes are supplied by connecting the “blue” tube labeled “SAI” on the tubing bundle to a regulated air source. The outer set of shaping air holes are supplied by connecting the “gray” tube labeled “SAO” on the tubing bundle to a regulated source. The air supplies work in combination with each other to provide desired results. This combination of shaping air can be used with the 55mm bell cup.

NOTE

- A minimum of 70 slpm (2.6 SCFM) should always be kept flowing in the inner shaping air passage to keep the face of the applicator clean during manual cleaning breaks.

BRAKE AIR

Brake air is used to slow the turbine speed in a minimum length of time. It is advantageous for short cycle times during color change, or may be used to reduce speed or stop the turbine. Never operate brake air with the turbine air on.

ELECTROSTATIC VOLTAGE

The RMA-570 Indirect Applicator receives its high voltage via high voltage cable A10560-XX. The voltage is then passed through eight (8) total resistors located in the A11343-XX electrode assemblies mounted on the A12079-00 high voltage ring. An ionized field is established between the probe tips and the electrically grounded bell cup as well as the electrically grounded work piece.

Refer to the current MicroPak service manual for detailed operating instructions, safety cautions, and settings

Service Manuals:

MicroPak (LECU5004)
LN-9218-00.X

MicroPak 2e (A13613-XX)
LN-9265-00.X

NOTE

- If paint defects occur, such as fatty edges or picture framing, reducing the voltage should be a last resort. To correct the problem, lead and lag trigger adjustments should be optimized first.
- The electrostatic voltage applied to the RMA-570 will affect pattern size, transfer efficiency, wrap and penetration into cavity areas. A setting of 30-70 kV is appropriate for most direct charge applications and 30-70 kV for most indirect charge applications.

TARGET DISTANCE

The distance between the RMA-570 atomizer and the target will affect the finish quality and efficiency. Closer distances give a smaller pattern, wetter finish, and greater efficiency. Greater distance will provide a large pattern size and drier finish. The MicroPak control circuit will enable the applicator bell to be operated to within a few inches of the target without adjusting the voltage setting. The recommended target distance is 6 to 12-inches (152.4-304.8mm). In general, allow 1-inch (25.4mm) target distance for every 10kV.

GENERAL OPERATING SEQUENCE



CAUTION

- It is recommended to leave bearing air on, unless the applicator is being serviced or removed for service.

Normally, for painting application, the process sequence should always be:

- Bearing air on (always On)
- Turbine air on
- Turbine speed to application speed
- Shaping air on
- Start fluid flow off part
- Voltage on

After spraying the object, the sequence should be:

- Voltage lowered to 40-50 kV
- Fluid off
- Shaping air to setback volume
- Turbine speed to set back speed (30,000 rpm recommended)

Recommended sample cup flush sequence is as follows:

1. Turbine speed set to 25-30,000 rpm.
2. Shaping air set to 350-450 slpm (12.4-15.9 SCFM).
3. Point atomizer at a grounded object such as a booth grate. Leave voltage on at 40-50 kV.
4. Assure that solvent solution is heated to 120°F (49°C) at the applicator.
5. Maintain solvent pressure of 100-150 psi (689-1,034 kPa). Maintain air push pressure at 80-100 psi (552-689 kPa).
6. Use an alternating sequence of solvent/air to create a chopping effect. Always insure that the last step in the sequence is an air push.

A typical sequence is .2 seconds solvent, 1.0 second air push, 1.7 seconds solvent, and 2.0 seconds final air push. This sequence may be modified for other paints and applications.

If the atomizer is utilizing an applicator cleaning box, voltage must be turned off.

7. It is recommended that an in-line fluid filter be installed to ensure that no foreign debris enters the fluid tip or the external wash nozzle. The fluid filter must be able to withstand at least 160°F (71°C).

The RMA-570 is versatile in processing the finish of a component. It can be setup as shown in Figures 9 and 10 to process the typical finish of a target.

Recommended sample cup purge sequence is as follows (internal cup cleaning):

1. Turbine speed set to 25,000-30,000 rpm.
2. Increase shaping air to 350-450 slpm (12.4-15.9 SCFM).

3. Paint atomizer at booth grate or insert into bell cleaning station. Reduce high voltage to 40-50 kV.

4. Maintain solvent pressure of 100-150 psi (689-1034 kPa). Maintain air push pressure at 80-100 psi (552-689 kPa).

5. Use an alternating trigger sequence of solvent/air to create a chopping effect. Always insure that the last step in the sequence is an air push.

6. A typical sequence is .3 seconds solvent, 1.7 seconds air push; repeat 3 times. This sequence may be modified for other paint and applications.

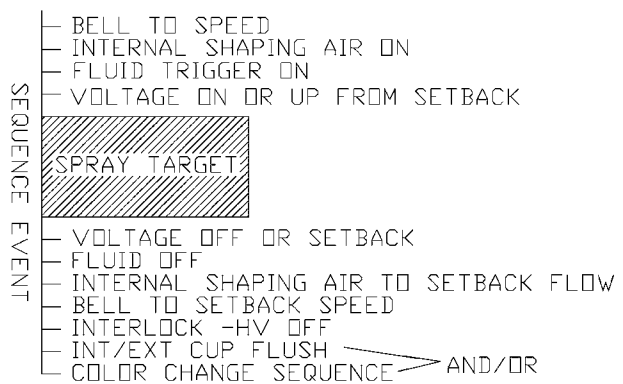

Figure 9: Typical Paint Sequence

Sequence Event Explanation:

1. **Bell to Speed** - This is accomplished by a set point command from either the PLC, robot, or other input device.
2. **Shaping Air On** - From a setback amount, a signal is sent to air control to increase direct flow to a desired level to achieve pattern size, film build, transfer efficiency, etc. Shaping air should never be set below 70 slpm (2.6 SCFM) air flow rate.

3. **Voltage On** - The voltage is turned on from a signal to the MicroPak. The lag time to full voltage may be reduced if a setback voltage is used. Recommended setback voltage is between 30kV and 50kV.

4. **Trigger Fluid** - An air signal is sent through the PT line of the tubing bundle. This should occur when the target is 6-12-inches (152.4-304.8mm) from the applicator centerline. (Not to be confused with target distance.)

5. **Voltage Off/Setback Voltage** - Immediately precedes the trigger off. Using a setback voltage shortens the cascade voltage ramp up-time.

6. **Fluid Trigger Off** - This should occur when the target is typically 0 to 6-inches (0-152.4mm) past the applicator.

7. **Shaping Air to Setback** - The setback flow of air should never be below 70 slpm (2.6 SCFM).

8. **Color Change Sequence** - Used when color is changed one to the other. Typical sequence is shown in Figure 7. **(Note: During this sequence, the applicator should be moved to a position to collect the waste material.)** The sequence shown is a starting point for processing, but the final sequence will depend on the material being sprayed and the solvent used to purge the applicator with.

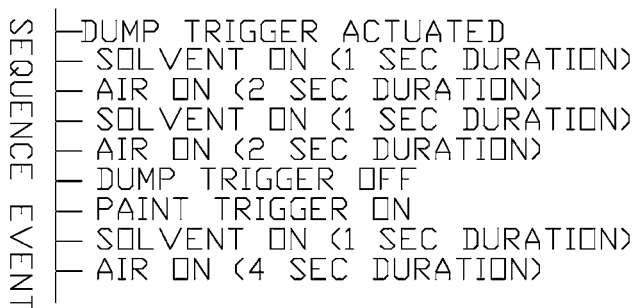

Figure 10: Typical Color Change Sequence

PROTECTIVE COVERS

It is recommended to use covers to reduce the amount of overspray build-up on the shroud and electrodes. Two covers are available, a white lint free stretch cloth for covering the probes and a foam cover (green) for the front shaping air shroud. The white cloth cover should cover all of the electrode except for the last 1-inch (25-4mm). The green foam cover should be installed until just past the radius edge of the shroud. Care is to be taken when installing the white cloth covers over the electrodes, do not bend them. (Devise a fixture to help slide the cover over easier.)

When cleaning, do not get covers wet, it will attract more overspray, more quickly. Push them back, clean surface, dry thoroughly, and slide back to original position. Depending on conditions, covers should be replaced after each shift (8 hours).

Covers:

- A11565-00 White Stretch, Lint Free Covers
- A11564-00 - Foam Elastic Covers (Green)

⚠ WARNING

➤ Make sure covers DO NOT trap moisture. Moisture on covers can inhibit the performance of the applicator. Large amounts of trapped fluids can become floating grounds. These conditions may lead to unwanted sudden discharge of energy in the form of a spark.

MAINTENANCE

O-RINGS

All O-rings in this atomizer are solvent proof except the ones on the air bearing spindle. These O-rings must not be soaked in solvent; if these are exposed or soaked in solvent, they must be replaced. These O-rings are engineered to provide a fit between the air bearing spindle and it's mating parts to reduce or eliminate harmonic resonance (vibration).

Some O-rings are encapsulated. These O-rings have a limited amount of stretch and will not return to their original diameters if over stretched. These O-rings are subject to being distorted more easily than rubber O-rings, so it is important that they be sufficiently lubricated when mating parts are installed onto them. They also will take a square set over time and should be replaced periodically if mating parts are removed repeatedly or if a new mating part is installed onto them.

Any O-ring that is cracked, nicked, or distorted must be replaced.

A suitable lubricant is food grade petroleum jelly or A11545-00 Petrolatum Jelly.

CLEANING PROCEDURES

! WARNING

- Electrical shock and fire hazards can exist during maintenance. MicroPak supply must be turned off before entering the spray area and performing any maintenance procedures on the atomizer. Spray booth fans should remain on while cleaning with solvents.
- Never touch the atomizer bell while it is spinning. The front edge of the bell can easily cut into human skin or cut through gloves and other materials. Be sure the atomizer bell has stopped spinning before attempting to touch it. Approximate time for the bell to stop spinning after turning off turbine drive air is three minutes.
- Insure high voltage is off during any manual cleaning procedure.

In addition to the above Warning, which relates to potential safety hazards, the following information must be observed to prevent damage to the equipment.

! WARNING

- DO NOT immerse the RMA-570 turbine in solvent or other liquids. Turbine components will be damaged and warranty will be voided.
- Bearing air must be on during all cleaning procedures to protect the air bearing components.
- For best operating performance, all surfaces of the applicator must be dry.

Internal Fluid Path Purge Cleaning

Cleaning the incoming paint line (from paint supply source such as color manifold through the fluid manifold and bell assembly): Turn off the high voltage and turn on the color stack trigger valve for solvent supply. With the bell spinning, flush cleaning solvent through the incoming paint line and through the manifold passages, and out through the dump valve. Use restricted bell wash solvent to clean the fluid tube and bell cup. The spinning bell will atomize the solvent and clean out the bell passages. If desired, open the dump valve to flush through the dump line for a faster and contained system flush.

! WARNING

- The maximum flow rate of 1000 cc/min. must not be exceeded during a flush routine. Use of an in-line fluid restrictor is recommended.

External Atomizer Surface Cleaning

- Verify that the high voltage is turned off.
- All external surfaces may be cleaned using a mild solvent and lint free rags to hand wipe the RMA-570 Turbine drive air must be off, but leave bearing air on. The inner and outer shaping air should have approximately 70 slpm air flow through each to prevent the solvent from entering these passages.
- Always final wipe all parts with a non-polar solvent and wipe dry (high flash Naphtha, etc.).
- Do not spray the RMA-570 unit with a solvent applicator used for cleaning. The cleaning fluid under pressure may aid conductive.
- Materials to work into hard to clean areas or may allow fluids to be forced into the turbine assembly.
- Do not reuse an atomizer bell cup that shows any sign of damage such as nicks, heavy scratches, dents, or excessive wear.
- For best operating conditions, the atomizer surfaces must be dry.

⚠ WARNING

➤ **NEVER** wrap the applicator in plastic to keep it clean. A surface charge may build up on the plastic surface and discharge to the nearest grounded object. Efficiency of the applicator will also be reduced and damage or failure of the applicator components may occur. **WRAPPING THE APPLICATOR IN PLASTIC WILL VOID WARRANTY.**

⚠ WARNING

➤ To reduce the risk of fire or explosion, OSHA and NFPA-33 require that solvents used for exterior cleaning, including bell cleaning and soaking, be nonflammable (flash points higher than 100°F/37.8°C). Since electrostatic equipment is involved, these solvents should also be non-polar. Examples of non-flammable, non-polar solvents for cleaning are: Amyl acetate, methyl amyl acetate, high flash naphtha, and mineral spirits.

➤ Do not use conductive solvents such as MEK to clean the external surfaces of the RMA-570 without a second cleaning with a non-polar solvent.

➤ When using a rag to hand wipe the RMA-570, the turbine air should be off, but leave both the shaping air and bearing air turned on. Insure that rotation has come to a complete stop.

VIBRATION NOISE

If the RMA-570 is vibrating or making an unusually loud noise, it usually means there is an imbalance situation. The atomizer bell cup may have dried paint on it or the bell may be physically damaged., or there may be paint trapped between the bell cup and shaft preventing the bell cup from properly seating. If any of these conditions exist, they **MUST** be corrected. Excessive imbalance caused by one of the conditions may result in bearing damage and turbine failure. Warranty **DOES NOT** cover failure caused by imbalanced loading conditions.

To determine if the bell is dirty or damaged, remove the bell cup and turn the turbine ON. If the noise is eliminated, the bell cup is the problem. If the noise continues, the turbine may be damaged and should be inspected. Excessive air required to achieve same speed may indicate a faulty or contaminated turbine. **DO NOT** continue to operate a noisy turbine.

! WARNING

➤ If a bell cup comes off a rotating shaft because of motor seizing or any other reason, the atomizer and bell cup must be returned to Ransburg for inspection and evaluation to determine if the bell can be used in operation.

TURBINE MAINTENANCE

DO NOT attempt to rebuild the turbine. Any endeavor to disassemble a turbine during the warranty period will void the warranty. The turbine is non-field serviceable. Contact your authorized distributor or Ransburg for instructions.

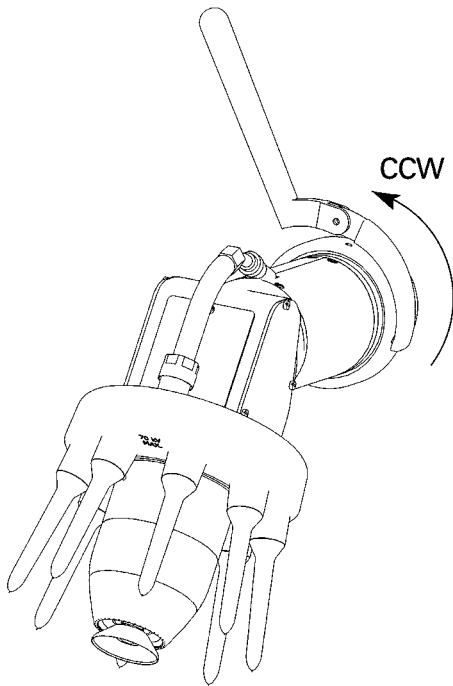

Figure 11: Applicator Removal from Robot

GENERAL MAINTENANCE

Verify daily that the operating parameters have not varied significantly from the normal. A drastic change in high voltage, operating current, turbine air, or shaping air, can be an early indicator of potential component failure.

A laminated poster entitled “Rotary Atomizer Checklist” (AER0075-02) is included with the assembly in the Literature Kit to be posted near the station as a handy reference.

Due to the close proximity of high voltage to ground potential, a schedule must be developed for equipment maintenance (cleanliness).

PREVENTIVE MAINTENANCE

Daily Maintenance (During Each Preventive Maintenance Break)

1. Verify that high voltage is OFF and that both inner and outer shaping air, bearing air, and turbine drive air are ON.
2. Open the dump valve, flushing all paint from the supply lines and valve module.
3. Open the solvent valve, flushing all paint from the fluid tube and through the atomizer bell assembly.
4. Re-verify that high voltage is OFF, turbine drive air is OFF, and that the bell cup has stopped spinning. The bearing air and shaping air should remain ON.
5. Clean all external surfaces of the applicator using a lint-free rag dampened with solvent.
6. After cleaning, all conductive residue must be removed using a non-conductive solvent. Since electrostatic equipment is involved, these solvents should also be non-polar (Naphtha).

REPLACEMENT ELEMENTS		
Part No.	Quantity Elements Per Carton	Used On
HAF-5	1	HAF-15, Pre-Filter
RPM-32	4	RPM-417, Pre-Filter
RPM-33	8	RPM-418 Bearing Air Filter

7. Inspect bell cup for nicks, dents, heavy scratches, or excessive wear. Replace if necessary.
8. Check bell cup tightness. Tighten to 50-70 lbs•in (5.65-7.91 Nm) torque.
9. Check the amount of paint build-up on the outer protective cloth covers, if used. If excessive, replace covers as required. If cloths are wet, find source and replace with dry cloth covers.

WARNING

- The high voltage must be turned OFF before entering the spray area and performing any maintenance procedures. Spray booth exhaust fan(s) should remain ON while cleaning the equipment with solvents.
- Make sure high voltage is OFF before approaching applicator with solvent cloth.
- DO NOT use reclaim solvent containing d-Limonene. This can cause damage to certain plastic components.
- DO NOT stop bell rotation by using a rag or gloved hand against the bell cup edge.
- **Maximum flow rate should not exceed 1000 cc/min.**
- Daily removal and soaking of the bell cup may not be required if the bell cup is properly flushed. However, the frequency of the feed tube and internal motor shaft inspection indicated below under weekly maintenance can be done daily and later adjusted to weekly or as required depending on the results of the inspection.

NOTE

- Normally the cloth covers will not need replacement daily and could last about one week depending on application. (See “Weekly Maintenance” in the “Maintenance” section.)

Weekly Maintenance

(Prior to Start or End of Production Week)

- Monitor rotational speed of all bells at the speed control.
- Monitor high voltage and current output indicated on the MicroPak display.
- Check paint flow on all bells at minimum and maximum specified settings by taking beaker readings.
- Check solvent flow by opening solvent valve and taking a beaker reading (should be within approx. 10% of target flow rate).

WARNING

- Maximum flow rate should not exceed 1000 cc/min.

- Paint residue found in the shaping air holes is not acceptable and must be removed prior to applicator use (see “Cleaning Shaping Air Holes” in the “Maintenance” section).
- Remove protective cover from outer housing and discard. Clean any paint on outer surface of front and rear housing with soft cloth dampened with solvent. (See “Warning” on previous page, on avoiding the use of cleaning solvent containing d-Limonene.)
- Remove the front shroud and check for any signs of solvent or paint leakage. Clean as required or repair as required.
- Remove bell cup and soak in solvent for 1-2 hours. Clean with a soft brush as required. Remove from cleaning solution and blow dry before replacing.

NOTE

► It may be necessary to remove the bell cups for cleaning more frequently than weekly. (See Note under “Daily Maintenance” in the “Maintenance” section.)

- With bearing air off, carefully inspect the feed tube tip and clean any paint build-up that has occurred on the feed tube tip. Using a pen light, determine if there is build-up of paint in the motor shaft and/or around the paint feed tube. If so, remove the motor assembly following the disassembly procedures and clean out the inside diameter of the motor shaft using a tube brush and solvent. Clean the outer surfaces of the feed tube.

WARNING

► Make sure that no solvent or other contamination is allowed to enter the motor assembly (air bearing and outer shaft).

- Recheck bell cup tightness. Torque to 50-70 lbs.- in. (5.65-7.91 Nm).
- Remove the rear shroud to expose the fluid valve manifold assembly. Visually inspect for signs of fluid leaks around fluid connections and manifold. Correct problem and clean paint from all components, including internal portion of shroud.
- Reinstall rear shroud, bell cup, and front shroud and replace cover on the outer housing (Refer to “Disassembly Procedures” in the “Maintenance” section for definite instructions).

BELL CUP PREVENTIVE MAINTENANCE

It is the user’s responsibility to insure proper maintenance of the atomizer bell at all times. Bell cup failure due to inadequate cleaning or handling will not be covered under Warranty. The “DO NOT” bullets (see “Operator/Maintenance Warnings” in the “Maintenance” section) listed are some examples of improper handling which could adversely affect performance or personnel safety and should not be attempted for any reason.

Bell Cup Handling

Always verify that high voltage is turned off and the atomizer bell has stopped spinning before performing any type of handling maintenance.

Bell Cup Replacement

Bell cup wear is dependent on many factors such as bell speed, flow rate, and type of coating being applied.

The bell cup shown in the following photos indicates if a bell cup has some usable life or should be replaced. Photo 1 shows a bell cup that has some usable life. The grooves worn around the splash plate pins are shallow. The general appearance of the cup surface is smooth and uninterrupted. Photo 2 shows a bell cup that needs to be replaced, as well as the splash plate that was installed into the cup. The grooves are deep, a visible groove exists at the outer edge diameter of the splash plate and there are noticeable lateral grooves extending towards the outer edge of the cup.

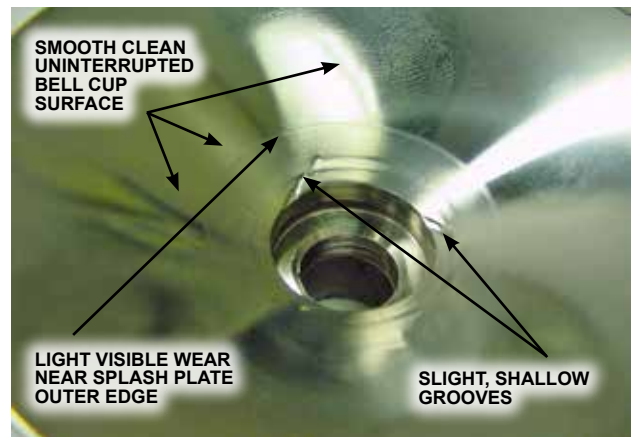

Photo 1

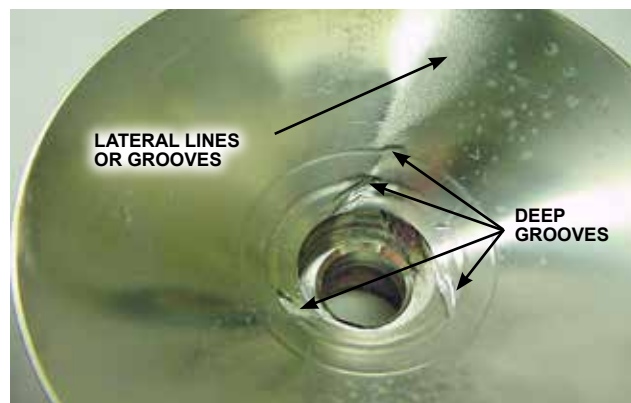

Photo 2

BELL CUP CLEANING

Always verify that high voltage is in degrade mode of 40-50 kV and that the atomizer bell is spinning before performing any type of color change or bell flush cleaning cycle.

To reduce the risk of fire or explosion, the solvents used for exterior cleaning must have flash points above 100°F (37.8°C). Since electrostatic equipment is involved, these solvents should also be non-polar.

Solvents used for equipment flushing should have flash points equal to or higher than those of the coating material being sprayed.

1. The atomizer bell will normally be fully cleaned during a bell flush cycle. Flushing should be done before any down time or break in production. A bell flush cycle may also be required while spraying batch parts of the same color. Verify that high voltage is in degrade mode of 40-50 kV and that the atomizer bell is spinning before flushing through the bell.
2. If there is any remaining paint build-up on any areas of the bell after flushing, the bell cup should be removed for hand cleaning. The bell's leading edge, splash plate, serration cuts, and rear of cup are some examples of areas for special attention.

Bell Cup Soaking

3. Bell cups and splash plates can be soaked in a heated solution for up to 2 hours in an ultrasonic cleaner (120°F, 49°C maximum). Bell cups alone may be soaked for an extended amount of time.

Manual Inspection

4. Visually inspect the bell cup edge for signs of abrasion. If the edge is excessively worn or badly chipped as the result of a collision with a part, replace the cup immediately. ("Bell Cup Preventive Maintenance, Photos 1 and 2" in this section.)

5. Remove splash plate. Inspect for wear on the bell cup where the fluid leaves the large diameter of the splash plate. If any undercut in this area, the cup should be replaced. Also, check the three (3) pins between the front and rear splash plate halves. If worn, replace entire assembly.
6. Check the center holes of the splash plate for wear. Hold splash plate up to a light source and look straight into the holes. If light is clearly seen, splash plate must be replaced.
7. Splash plate assemblies may be soaked for a short time, under 2 hours, to loosen dried material. Clean with a soft bristle brush. Blow out center holes to dislodge material. Never use any kind of pick instrument to clean these holes.
8. Soaking the bell in solvent may aid in loosening or removing paint build-up. It is recommended that the splash plate be removed and cleaned separately.
9. Use a soft bristle brush dipped in solvent to remove paint build-up from the serration cuts, paint feed holes or slots, and external and internal surfaces of the bell.
10. Check the well cavity in the back of the bell cup. This cavity must be cleaned manually. It will not be cleaned during purge cycles or interior or exterior cup flushes.
11. A soft, lint free rag dampened with solvent may be used to remove any paint residue from the external and internal surfaces of the bell.
12. After removing all paint build-up or residue, rinse the bell in clean solvent and blow dry.
13. Before reinstalling the bell on the shaft, check the mating surfaces of the thread and taper for any paint build-up or residue. Also, check the fluid tip, fluid tube outside diameter, and the shaft for any further paint build-up. These surfaces should be cleaned before installing the bell.
14. It is recommended that extra bell cups be purchased. The cups can then be cleaned off line in an automated cup cleaner.
15. Reinstall cups to proper torque 50-70 lbs. - in. (5.65 - 7.91 Nm).

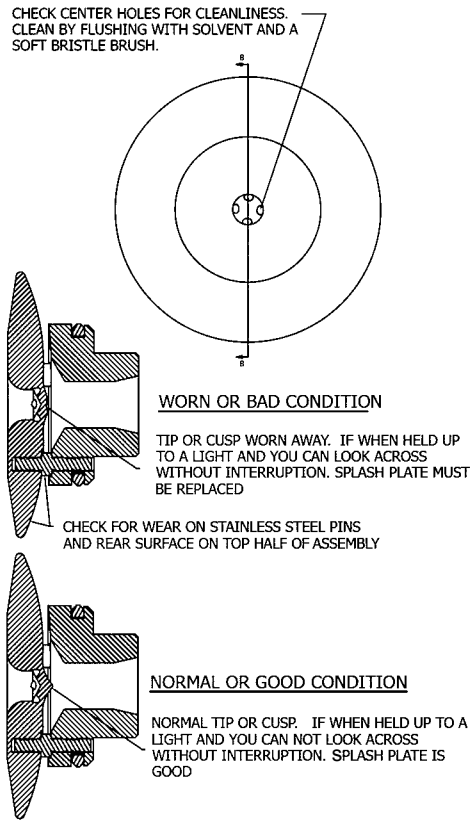

Inspection of Bell Cups

Periodically (weekly) the outer shaping air cap and the inner shaping air ring should be removed and thoroughly cleaned. Use of an ultrasonic cleaner would make cleaning of hole diameters easier. Inspect all holes for blockage. Blow holes clear with compressed air after some time of soaking in solvent. **DO NOT use any type of pick to clear the holes.** Damage may result to parts and could affect performance of the equipment. If holes are damaged (oversized holes, blockage, and gauges) it must be replaced.

CLEANING SHAPING AIR HOLES

In order to maintain uniform pattern control, the shaping air holes of the inner ring and the shaping air cap must be clean and free of any blockage.

It is best to leave the shaping air supply ON during normal production break cleaning periods. Shaping air can be reduced to 70 slpm during this time. This will help stop material from entering the passage ways.

RMA-570 PREVENTIVE MAINTENANCE SCHEDULE								
Procedure	Frequency (Maximum)							
	Mid-Shift	End of Shift	Weekly	2 Weeks	Monthly	3 Months	6 Months	Yearly
Mid Shift Cleaning • Wipe electrodes • Wipe shroud • Visually inspect cup	●							
End of Shift Cleaning • Wipe electrodes • Wipe shroud • Wipe bell cup down • Change cloth cover		●						
Shaping Air Shroud • Clean inner shape air ring • Clean outer shape air ring • Remove and clean	●	●	●					
Bell Cup/Splash Plate removal/inspection/cleaning		●	●					
Fluid tip inspection/cleaning		●	●					
Inspect Valve and Seat Assembly in valve module for leaking				●				
Replace Valves and Seats in valve module							●	
High Voltage Cable Inspections				●	●			
High Voltage Testing						●		
Regreasing of High Voltage Cables						●		
Check resistance of High Voltage Electrodes						●		
Regreasing Electrode Cavities of High Voltage Ring and High Voltage Input						●		
Inspect all screws • Replace if broken • Inspect for wear • Tighten per specifications						●		
Inspection of Electrode			●					
Replace Electrodes							●	
Inspection of Tubing Bundle					●			
Regrease Tubing Bundle							●	
Replace Tubing Bundle								●
Replace High Voltage Cable								●
Inspect Turbine Spindle taper and threads		●	●					

(Continued On Next Page)

RMA-570 PREVENTIVE MAINTENANCE SCHEDULE (Cont.)								
Procedure	Frequency (Maximum)							
	Mid-Shift	End of Shift	Weekly	2 Weeks	Monthly	3 Months	6 Months	Yearly
Replace Bell Cups						●	●	●
Replace Splash Plates						●	●	
Inspect and Clean Spindle Bore and Fluid Tube OD		●	●					
Check High Voltage Contact area for damage/arcing		●						
Inspect for Fluid Leaks	DAILY							
Check Exterior of High Voltage Ports for degradation	●							
Check External Cup Flush Carbide Tip for blockage	●	●						

NOTE

➤ The outer protective cover may have to be replaced more frequently than weekly. Daily inspection of the amount of paint build-up on the cover will determine the frequency of replacement.

WARNING

- Prior to removing applicator from the robot, the following tasks must be completed.
- Robot put into E-stop mode, locked and tagged out.
- All fluid passages are cleaned, purged out, and depressurized.
- Air turned off.
- Carefully remove the quick disconnect ring to insure any residual line pressure has been relieved to atmosphere.

DISASSEMBLY PROCEDURES

- For reassembly instructions, use the reverse of the following disassembly procedures.
- To facilitate atomizer removal from hose manifold, a robot program should be made that purges all paints and solvents from the RMA-570. Ideally it would then position the bell assembly in a bell removal position where the bell cup is pointed downward at a 30° angle. Any residual solvents would be contained in the “J bend “ of the robot wrist.
- All O-rings described in the “Maintenance” section of this manual should be lubricated with a food grade petroleum jelly or with A11545 lubricant.

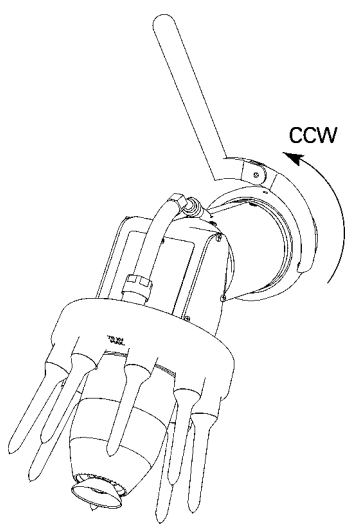

Figure 13: Applicator Removal from Robot

Atomizer Removal (See Figure13)

Remove rear split shroud by loosening the flat head retaining screws and pulling the shroud halves away from the atomizer extension. Loosen the high voltage nut (78441-00) that holds the high voltage cable into the curved high voltage tube. Remove the high voltage nut and ferrules from the high voltage cable. Loosen the quick disconnect ring (A11201-00) with the adjustable spanner wrench (76772-00) in a counter-clockwise direction. Pull atomizer away from robot plate while taking care to feed the high voltage cable back through the atomizer.

Atomizer Reassembly

Rear shroud halves must be removed for atomizer reassembly. Insert the high voltage cable through the center hole of the atomizer and feed the banana jack end through the hole in the atomizer extension. Once the cable is through, slide the applicator towards the robot plate and align the two guide pins with the holes in the robot plate. Push the atomizer to the robot plate until both plates are flush. Engage the mounting ring and tighten securely. Remove the curved high voltage tube from the high voltage ring. Slide the high voltage nut and ferrules onto the high voltage cable, and then slide the curved tube over the high voltage cable. Leave assembly loose. Insert the banana jack end of the cable into the rear opening in the high voltage ring until it seats firmly. Slide the curved tube towards the high voltage ring and secure in place by tightening the large locknut (A11318-00) by hand. Insure high voltage cable is in place before tightening high voltage nut and ferrule (78441-00) by pushing high voltage cable towards the high voltage ring. Tighten nut and ferrule securely by hand. Reinstall rear shroud halves. Tighten screws 3-5 lbs.- in. (.34-56 Nm) torque.

Proper high voltage cable installation may be verified by checking probe resistance from electrodes to the end of the high voltage cable per the use of a Yakogawa megohm meter or equivalent. Attach one lead to the end of the high voltage cable and touch the other end to the wire at the tip of each electrode, one at a time. The reading should be per "Chart A". If not, recheck connection in the high voltage ring.

High Voltage Ring Removal/Replacement

Loosen the high voltage locknut (A11318-00) and pull curved tube from back of high voltage ring. Grasp the high voltage ring and turn counter-clockwise approximately 10-15° until locking pins disengage. Pull ring forward to remove.

To reassemble, insure o-ring on inside diameter of the high voltage ring and on face of atomizer extension are seated properly in their grooves. Lightly lubricate both O-rings with A11545-00 petrolatum jell. Slide high voltage ring onto atomizer body making sure high voltage input is located at the top of the unit. Push firmly until it stops against the atomizer extension and is engaged on the locking pins. Rotate high voltage ring clockwise 10-15° to lock ring into place. Some force may be required with a new ring, but a solid lock will be felt when properly installed.



WARNING

- Before installing high voltage ring, fill the cavity in the high voltage ring with dielectric grease between the input and the outer diameter).

Before installing the curved tube, ensure the outer ring of the high voltage input is filled with new dielectric grease. Reinstall high voltage cable and curved tube and tighten locknut securely by hand. Proper high voltage cable installation can be verified by checking probe resistance from the electrodes to the end of the high voltage cable per use of a Yakogawa megohm meter or equivalent. Attach one lead to the end of the high voltage cable and touch the other end to the wire at the top of each electrode, one at a time. The reading should be per "Chart A". If not, recheck connection in the high voltage ring.

CHART A - PROBE RESISTANCE CHECK			
Ring Type	Part #	Resistance Reading	Used At (Location)
8 Probe*	A11343-03	133-147 Megohms	Above 5000 Ft. with In-Line Resistor
8 Probe	A11343-02	209-231 Megohms	Sea Level

* When this electrode assembly is used, you must use the 78442-00 In-line Resistor Assembly for the 74793-XX RansPak cascade and the 78809-00 ground resistor assembly. The ground resistor assembly is placed between the atomizer ground connection and a true earth ground source.

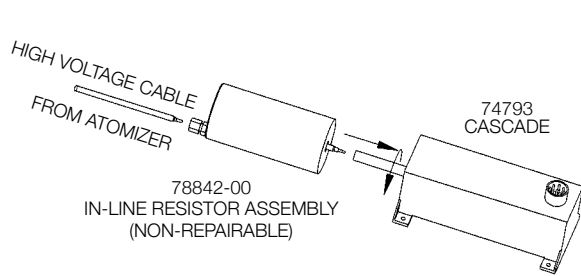

Figure 14: 78842-00 In-Line Resistor Assembly

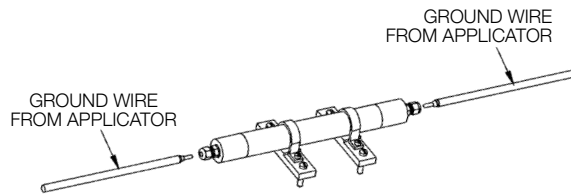

Figure 15: 78809-00 Ground Resistor Assembly

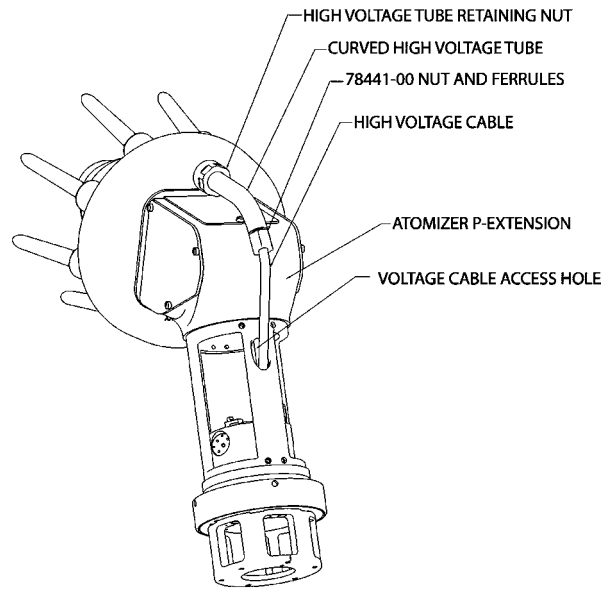

Figure 18: High Voltage Cable Installation

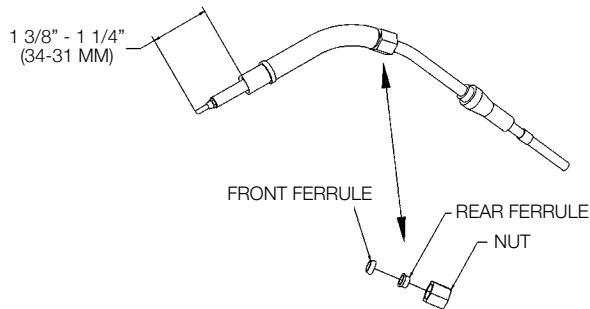

Figure 16: 78441-00 Ferrule Orientation

HIGH VOLTAGE CONNECTIONS FOR SHIELDED/ NON-METALLIC CORE CABLE - A10560-XX

NOTE

➤ Remove curved tube (A11691-00) and locknut (A11318-00) to ensure proper grooves are filled with dielectric grease before cable installation (see Figures 19 or 53). Remove and clean any excess grease after assembly.

High Voltage Connection - Cascade End

Insert end of cable (end of cable with the green grounding wire attached) thru compression nut of output tube of RansPak™ cascade (74793-01 or 74793-02) until it bottoms into banana jack receptacle. Tighten compression nut by hand, then tighten 1/2 turn more with a wrench. DO NOT over-tighten as this may damage cable.

Secure green wire with yellow stripe (attached to high voltage cable) to any known good earth ground, such as a water pipe, etc., using the attached ring terminal.

⚠ WARNING

➤ Arcing/fire hazard exists if ungrounded metal connections (air or fluid) are used in the spray area. Use plastic nonconductive connections, or ensure metal connections are at ground potential.

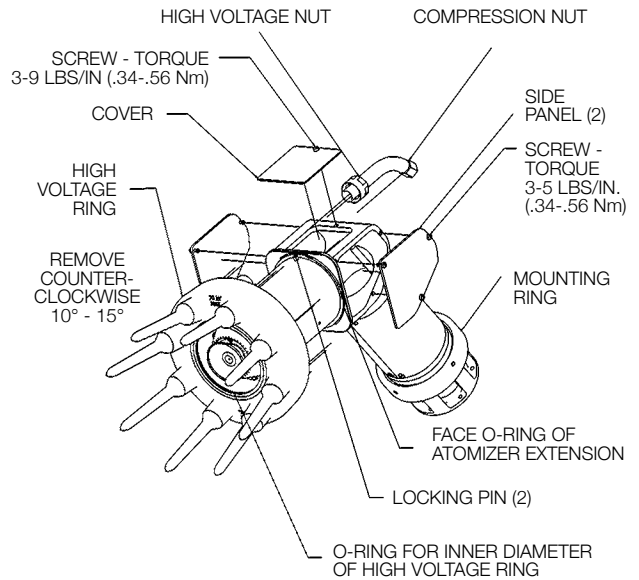

DO NOT FILL CENTER CAVITY WITH DIELECTRIC GREASE FILL THIS CAVITY WITH DIELECTRIC GREASE

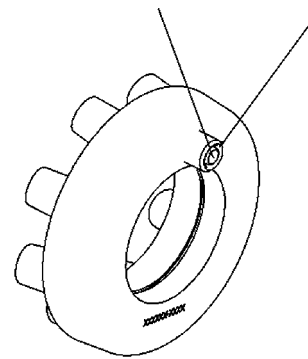

Figure 19: Atomizer Removal

Bell Cup Removal/Replacement

NOTE

- The bell cup should always be the first component removed if any maintenance is performed. Following the procedure will minimize the risk of damage to the cup itself.

Using the large open end of the wrench (A12061-00) on the flats of the turbine shaft, carefully hold the outside of the bell cup with one hand while applying a clockwise force to the wrench. The bell cup is a right hand thread and must be turned counter-clockwise to remove. Use latex gloves to obtain a firmer grip on the cup.

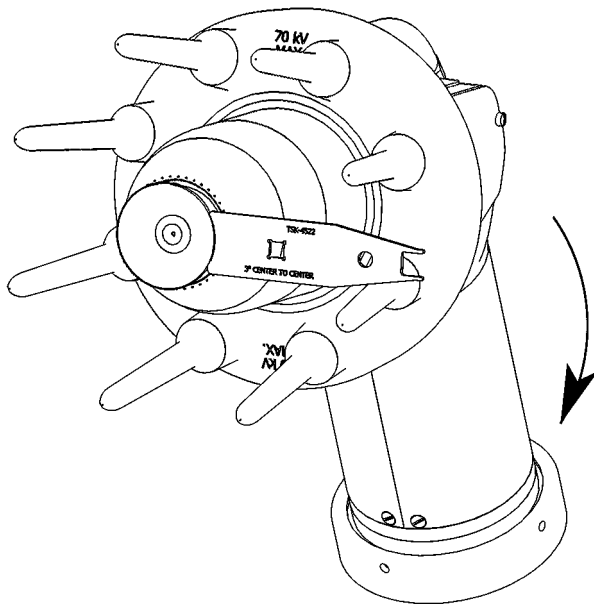

Figure 20: Bell Cup Removal

Place the bell cup in a safe, secure place. Carefully inspect the cup for any damage. If there is any damage to the cup, it must be replaced.

WARNING

- Failure to replace a damaged bell cup will cause premature turbine failure. Warranty will not be honored if the bell cup is damaged.

To re-install a cup, position the wrench as shown. Insert a torque wrench into the square in the wrench to approximately 50-70 Lbs.- In (5.65- 7.9 Nm) torque. Hold the cup and tighten the torque wrench in a counter- clockwise direction.

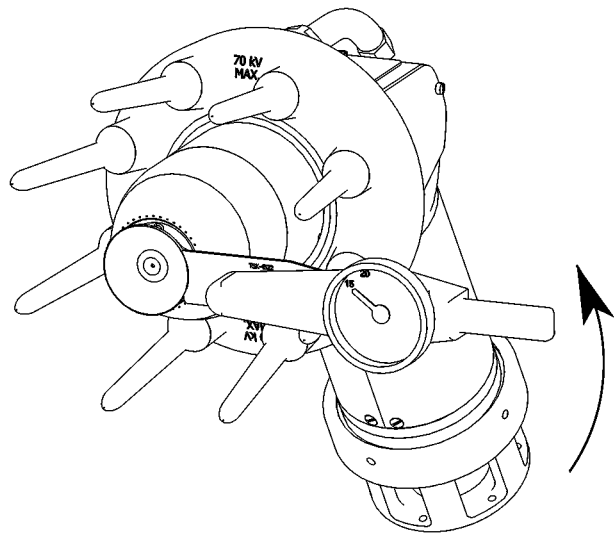

Figure 21: Bell Cup Installation

NOTE

- There is a 3- inch center-to-center distance between the bell cup and the 3/8 inch socket square on the wrench. This distance must be factored in when reading the proper torque on the wrench.

Example: A desired true torque is desired using a 9-inch effective length torque wrench. Wrench offset is 3-inches.

- L = 9-inches
- TT = 50 lbs.- in.
- E = 3-inches

DR is dial reading.

$$DR = \frac{50(9)}{(9+3)} \quad DR = 37.5 \text{ lbs./in.}$$

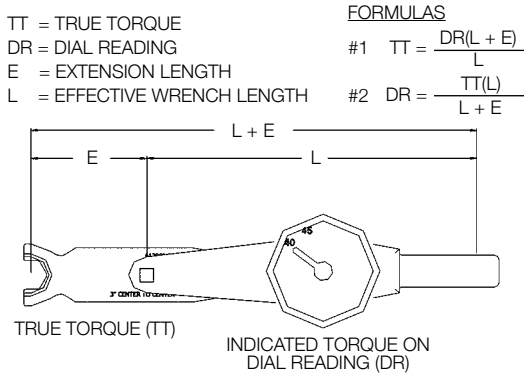

Figure 22: Effective Length Torque Wrench

Splash Plate Removal

After removing the bell cup from the applicator, put it on a plastic or wood surface to prevent damage to the edge of the cup. Using the splash plate removal tool (A11388-00), insert the small end of the tool into the end of the splash plate assembly. Press the splash plate out. It may be necessary to tap gently with a hammer.

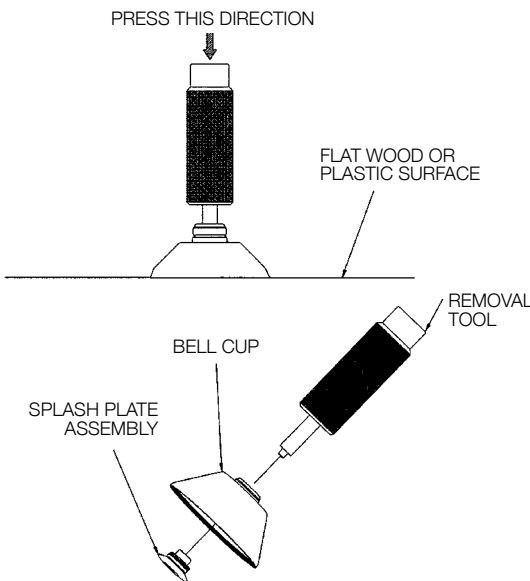

Figure 23: Splash Plate Removal

Splash Plate Insertion

Turn the splash plate removal tool over and use the large diameter end to press the splash plate back in place by hand. It may be necessary on occasions to use an arbor press to install the splash plate. Press splash plate to a hard stop (see Figure 24).

Care must be taken not to over-press the splash plate assembly into the bell cup. Damage may occur.

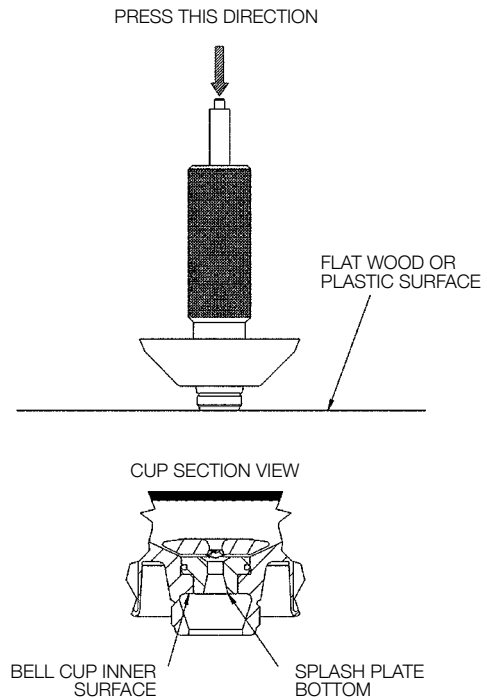

Figure 24: Splash Plate Insertion

▲ WARNING

- Failure to tighten the bell cup in place may cause vibration of the applicator and/or premature turbine failure.

Rear Shroud Removal/Replacement

Removal

Loosen flat head screws until they are loose. Screws are captured in the shroud and will come off with it as an assembly. Pry the edge of the shroud away from the atomizer extension while pulling it away from it. Repeat for other side.

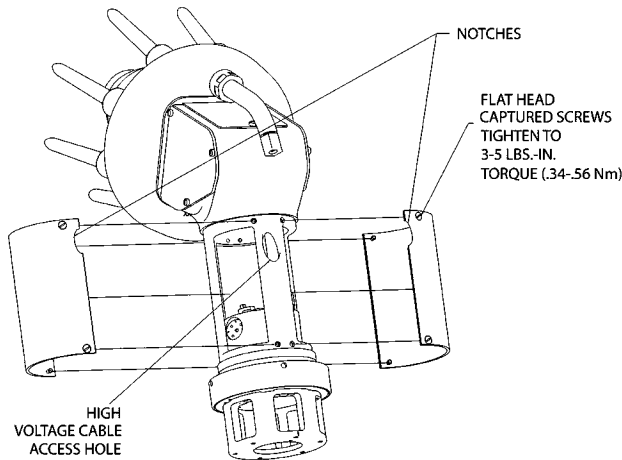

Figure 25: Shroud Removal

Replacement

Align the cut out notch of the shroud with the high voltage cable access hole of the atomizer extension. Snap into place and tighten all flat head screws to 3-5 lbs.- in. (.34-.56 Nm) torque.

Shaping Air Manifold, Solvent Tube Removal/Replacement

Removal

Remove the outer shaping air ring by turning it off by hand in a counter-clockwise direction. Remove the fitting, ferrule, and exterior cup wash line from the inner shaping air manifold by turning the fitting in a counter-clockwise direction using a 3/16" end wrench. Loosen set screw on inner shaping air manifold with a 5/64" hex wrench enough to allow manifold to be removed from the turbine body. Remove the inner shaping air manifold by turning it off in a counter-clockwise direction. A 1/4-20 threaded screw may be screwed into the cup wash port to provide additional leverage to remove the inner shaping air ring.

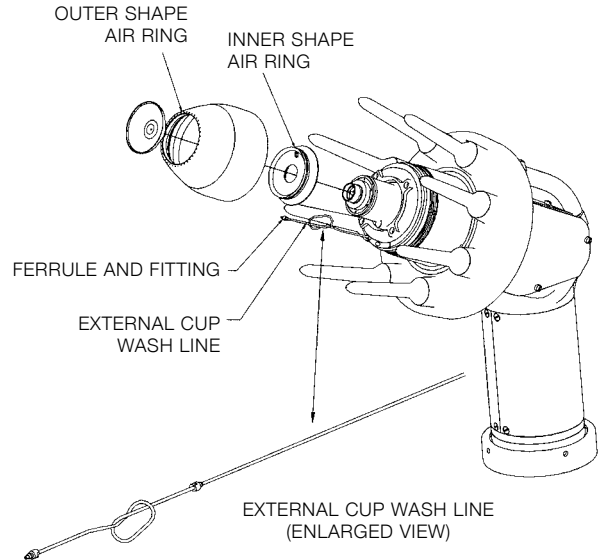

Figure 26: Interior/Exterior Shaping Air

Reassembly

(Lightly lubricate all O-rings prior to assembling.) Carefully install the inner shaping air ring onto the turbine threads. Tighten in a clockwise direction until it seats against the turbine. Tighten set screw to 5 lbs.- in. (0.564 Nm) torque to prevent shaping air ring/manifold from rotating. Do not over tighten! (Use a 5/64" hex key wrench.) If replacing the solvent tube, install into the atomizer body first and tighten with a 3/16" end-wrench. Before installing the other end into the inner shaping air ring, check the position of the 1/4-20 threaded hole. If it is less than 180° from the fitting installed in the atomizer body, you must install a loop (as shown in Figure 26) to prevent tube from becoming pinched when outer shroud is installed. Do not kink the tube when installing loop.

Turbine Removal / Replacement

Remove the turbine retaining ring by using the wrench (A12088-00), turning the turbine retaining ring in a counter-clockwise direction. Pull the turbine out while rocking it from side to side.

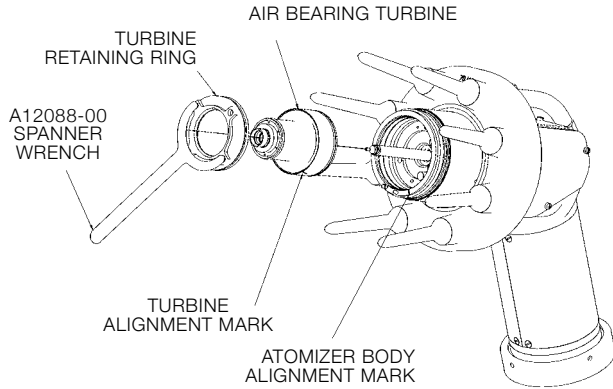

Figure 27: Turbine Removal

Replacement

Apply a light coating of O-ring lubricant to all the O-rings and the threads of the turbine and turbine retaining ring prior to assembly. Push the turbine down into the cavity in the atomizer body. Align the mark on the turbine with the mark on the atomizer body. Install the turbine retaining ring and o-ring by hand. Use the spanner wrench to tighten an additional 1/8-1/4 turn. (Lightly lubricate O-ring with petroleum jelly.) Check centering of fluid tube. If fluid tube is centered, the turbine is fully seated. If not, check tightness with spanner wrench. If tube is not centered, again remove turbine and check for causes, such as an O-ring fell off, fiber optic not fully installed, foreign material on seating surface, etc. Reinstall and recheck tube centering.

Fluid Tip Removal/Replacement

Removal

To remove the fluid tips, use the tip/tube removal tool (A11229-00). Insert the tool over the tip and engage the four (4) prongs of the tool into the four (4) slots in the tips (see Figures 28 and 29).

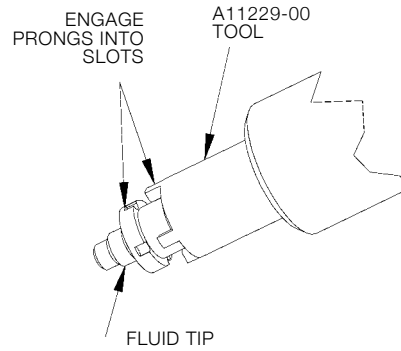

Figure 28: Fluid Tip Removal

NOTE

➤ To remove, turn the tip **CLOCKWISE**. The thread on the tip is **left handed**.

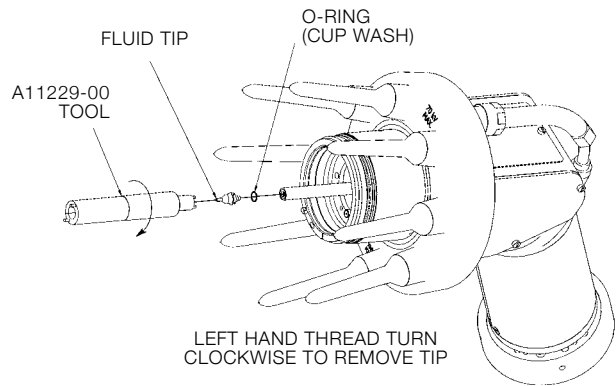

Figure 29: Fluid Tip Replacement

The fluid tip may be removed either with the turbine in place, or the turbine off the unit. Figure 30 shows removing/reinstalling the tip with the turbine in place.

This allows removal and replacement of the fluid tip while the applicator is on line.

Check for leaks.

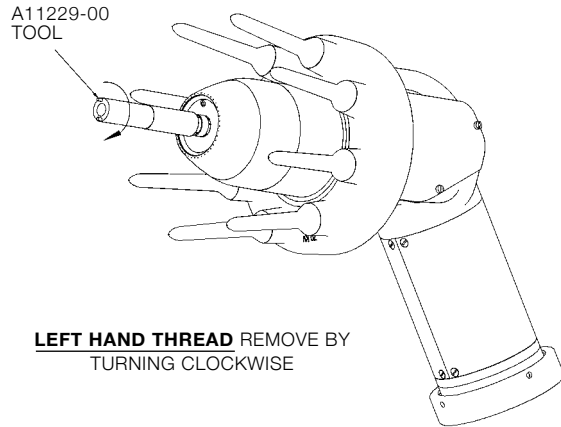

Figure 30: Reinstall Fluid Tip

Replacement

Ensure the tip openings are fully open and clean. Apply an O-ring lubricant to the O-ring to help hold it in place on the fluid tip. Insert the O-ring into the undercut groove on the tip. Place the tip on the tool and tighten in a counter-clockwise direction into the fluid tube. Do not over-tighten. There will be a small gap between the flange of the fluid tip and the fluid tube (see Figure 31). Insure the O-ring is properly positioned when complete. Tighten to 25-30 lbs.- in. (2.83-3.4 Nm) torque.

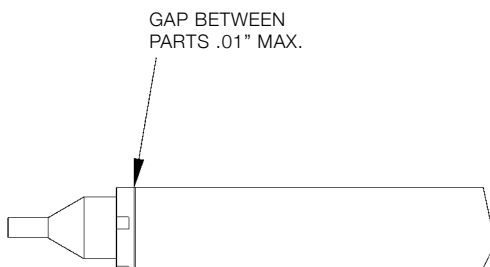

Figure 31: Fluid Tip/Tube Gap

⚠ WARNING

➤ When removing fluid tip while turbine is still installed, make sure to clean paint or fluid that may have leaked or run onto the shaft or threads.

Fluid Tube Removal/Replacement

Removal

Using the fluid tip/tube removal tool (A11229-00), place the pinned end of the tool towards the fluid tube retaining nut and engage the pins into the holes. Turn the tool counter-clockwise to remove (see Figure 32).

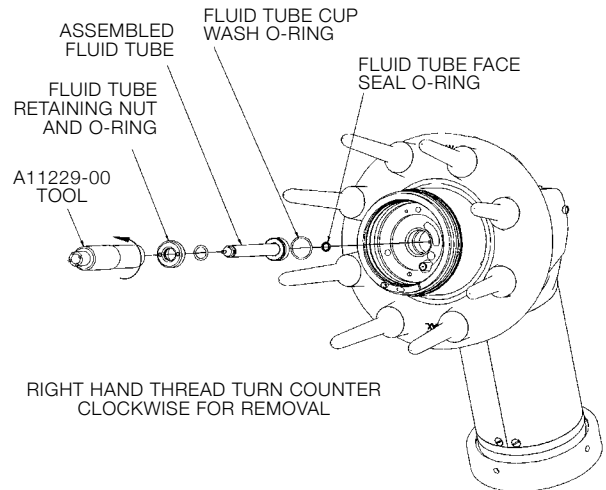

Figure 32: Fluid Tip Removal

Replacement

Lubricate all O-rings with a suitable O-ring lubricant. Push the fluid tube into the pocket of the atomizer body. Seat the tube by pushing while rocking the tube from side to side. Install the fluid tube retaining nut over the tube. Tighten the retaining nut firmly tight using the removal tool in a clockwise direction. Tighten to 65-75 lbs.- in. (7.34-8.47 Nm) torque.

Exterior Solvent Wash Line Removal/Replacement

Occasionally the exterior solvent wash line assembly (A11351-04) will have to be removed and replaced due to kinks or fitting ferrule leakage.

To remove, loosen fitting from valve manifold assembly (A11692-00) using a 3/16" end wrench. Cut the tubing above the fitting. Fitting may be reused, but the ferrule must be replaced.

Loosen the fitting at the shaping air inner ring and the atomizer body. Pull the entire tube through the atomizer body. Again, fittings can be reused, but ferrule must be replaced.

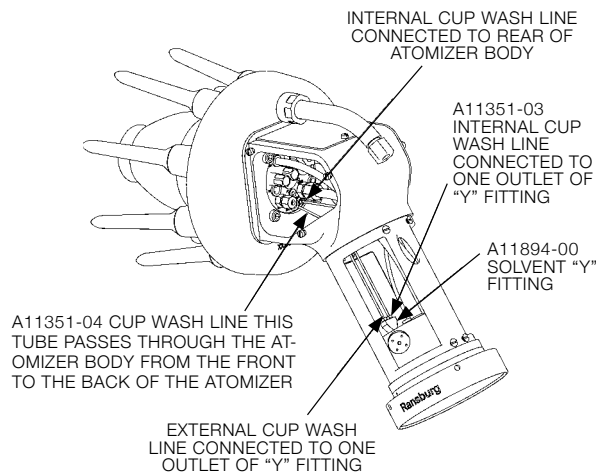

Figure 33: Interior/Exterior Cup Wash Tube Locations

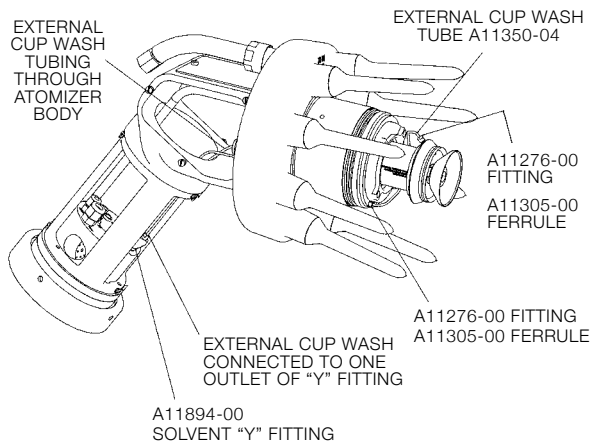

Figure 34: Exterior Cup Wash Tube ROUTE

To reinstall, insert open end of A11351-04 assembly into front of atomizer body and push all the way through. Install ferrule and fitting over tube and install at valve manifold end first! Tighten fitting to a stop, then 1/4 more turn. Next, pull some of the slack out of the line before tightening the next fitting and ferrule into the atomizer body. Tighten to stop and then 1/4 turn more. Next, tighten the remaining end of the tube into the inner shaping air ring. Tighten to stop and tighten 1/4 turn more.

Cup Wash Manifold Removal/ Replacement (Applicator Off Robot) (See Figures 35 and 36)

Removal

Remove the mounting ring by first removing the break-away ring. Loosen the six (6) 1/4-20 screws (using a flat blade screwdriver) that holds the break-away ring to the rear plate assembly. The break-away ring and the mounting ring will now come off.

Loosen the fiber optic assembly in the rear plate by loosening the set screw with a 3/32" hex key. Pull the fiber optic cable from its hole in the solvent manifold and rear plate assembly. Leave end loose in the atomizer extension.

Using the tubing removal tool (A11373-00), select the appropriate size end for the tube to be removed, 8mm or 6mm. The 8mm end will also fit over the 10mm green turbine air tube. Place the opening around the tube and press down on the quick release collet. Using your other hand, pull the tubing from the collet. Remove all tubing from the collets. Also, remove the fluid tubes held on with compression nuts.

On the cup wash manifold end, remove the cup wash line from the manifold by unscrewing the 1/4-inch fitting using a 3/16" end wrench. Leave line loose in atomizer extension.

Remove the six (6) 6mm screws holding the rear manifold to the atomizer extension using a 5mm hex key. Slide the rear plate and cup wash manifold assembly out. All the tubing should come with the assembly except the fiber optic and cup wash line.

Replacement:

To replace the cup wash manifold and rear plate assembly, you must have all the tubing in place on the cup wash manifold except the fiber optic and the solvent wash line. Lightly tape the tube ends together to ease installation. Slide the tubing into the atomizer extension, helping the tube make the bend at the front end of the atomizer extension.

Align the locating pin and the rear plate with the locating hole of the atomizer extension. Install the six (6) 6mm socket head screws. Tighten to 15 lbs.- in. (1.69 Nm) torque (see Figure 35).

Reattach all tubing at the atomizer end; reinstall the fiber optic cable into the rear plate. Tighten set screw to 10 lbs.- in. (1.13 Nm) torque.

Install the mounting ring onto the atomizer extension, threads facing rearward. Install the break-away ring. Align the four (4) locating dowel pins with the corresponding four (4) holes on the break-away ring. Install the six (6) 1/4-20 stainless steel screws. Tighten to 15-20 lbs.- in. (17 - 2.3 Nm) torque. If you are using the optional plastic break-away screws, tighten evenly to 5 lbs.- in. (.56 Nm) torque. The break-away ring must lie flat against the face of the rear manifold.

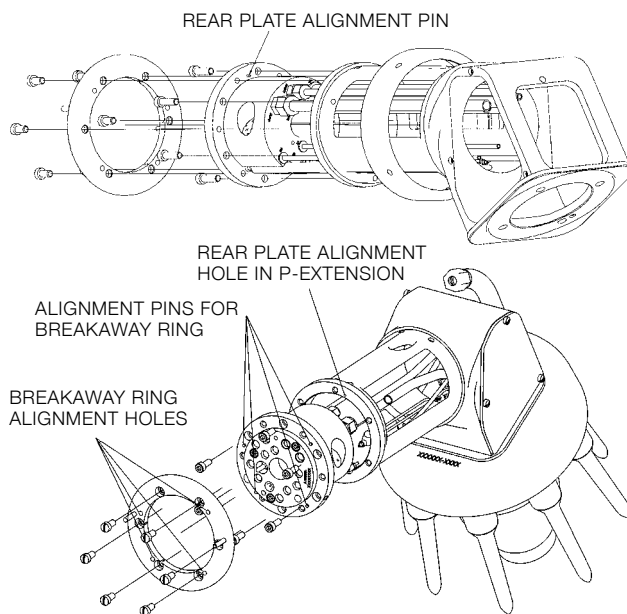

Figure 35: Cup Wash Manifold Removal/Replacement

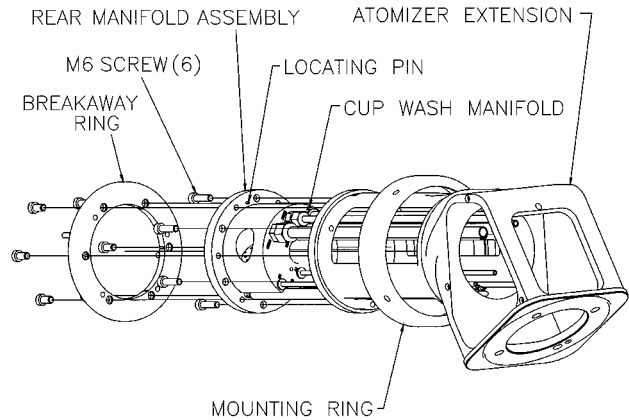

Figure 36: Cup Wash Manifold Removal

Separating Atomizer Body From Atomizer Extension (Applicator off Robot) (See Figures 37, 38, and 39)

Removal

Remove the mounting ring by first removing the break-away ring. Loosen the six (6) screws that hold the break-away ring to the rear plate assembly (see Figure 39). The break-away ring and the mounting ring will now come off.

Loosen the fiber optic assembly in the rear plate by loosening the set screw with a 3/32" hex key (see Figure 37). Pull the fiber optic cable from its hole in the solvent manifold and rear plate assembly.

Leave end loose in atomizer extension. Loosen and remove the cup wash line from the manifold by unscrewing the 1/4-inch fitting with a 3/16" end-wrench from the solvent manifold and leave loose in the atomizer extension.

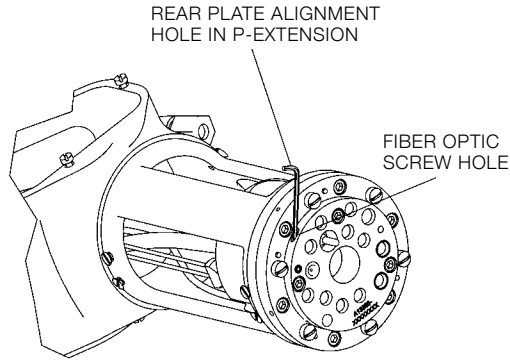

Figure 37: Fiber Optic Installation/Removal

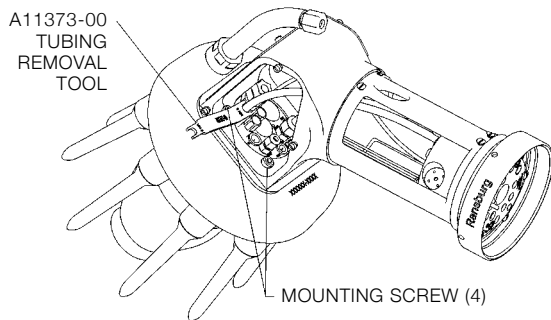

Figure 38: Tubing Removal

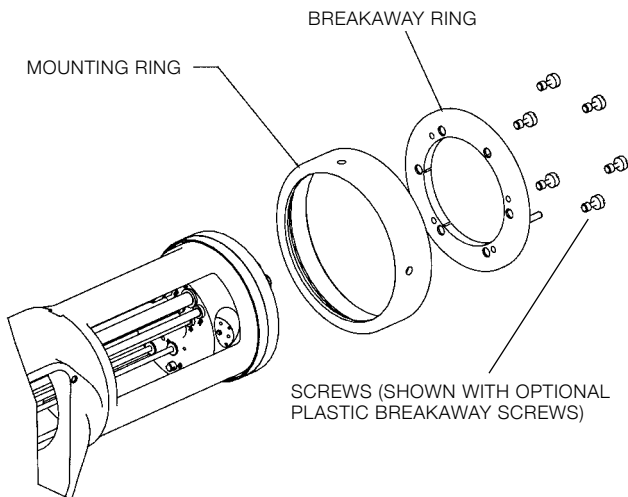

Figure 39: Break-Away Ring

Tubing Removal (Atomizer End) (Reference Figure 38)

Using the tubing removal tool (A11373-00) select the appropriate size end for the tube you want to remove, 8mm or 6mm. The 8mm end will also fit over the 10mm green turbine air tube. Place the opening around the tube and press down on the quick release collet. Using your other hand, pull the tubing from the collet. Remove all tubing from the collets and also remove the fluid tubes held on with compression nuts. Remove the four (4) mounting screws (M8 SHCS) that hold the atomizer body to the atomizer extension using a 6mm hex key.

NOTE

- It is important that the following procedure be adhered to in order that all tubing and fitting connections can be reached.

Reinstalling Atomizer Body On To Atomizer Extension

Before installing the atomizer body, the fiber optic sensor and cable must be installed as well as the small solvent line for the cup wash. Slide the cable and solvent line into the atomizer extension as you are guiding the atomizer body toward the extension. Rotate the atomizer body and align the “black” locating pin with the hole in the atomizer extension (see Figure 40). The atomizer body will pilot into a hole of the extension. When parts are flush, thread the M8 SHCS into the atomizer body from inside the atomizer extension. Tighten to 25-30 lbs.- in. (2.82-3.39 Nm). Install the paint and dump lines first. Make sure that the tubing is fully into the fitting before tightening the compression nuts using a 14mm wrench for the paint fitting nut and an 11/16” wrench for the dump fitting nut. It may be necessary to use a wrench on the fitting. Use a 13mm wrench for the 6mm paint fitting and a 16mm wrench for the dump fitting.

Starting with the tubing at the center most of the atomizer body, insert the tubing into the quick disconnect collets. Make sure tubing is fully inserted. (Reference Figures 41 and 42 for proper tubing locations.)

Install the fiber optic cable to the rear plate by going through the hole in the solvent/cup wash manifold. Align the flat on the fiber optic cable with the set screw and tighten to 10 lbs.- in. (1.13 Nm) torque.

Next connect the solvent line from the atomizer body to the solvent/cup wash manifold. Tighten carefully in place.

NOTE

>Make sure fiber optic cable is flush with face of rear plate assembly.

Slide mounting ring over atomizer extension, threaded end facing towards the rear.

Reinstall break-away ring by aligning the four (4) holes with the dowel pins on the recessed face of the rear manifold. Reinstall the six (6) stainless steel screws. Tighten evenly to 15-20 lbs.- in. (1.69 - 2.26 Nm) torque. If you are using the optional plastic break-away screws, tighten evenly to 5 lbs.- in. (.56 Nm) torque. The break-away ring must lie flat against the face of the rear manifold. Special Note: When replacing the tubing in the atomizer extension, make sure to slide tubing (76998-04 - Item 53) over the paint line (A10841-03 - Item 43) before installing nuts and ferrules onto fittings and tightening. This tubing is required as an extra dielectric shield when the high voltage cable is installed.

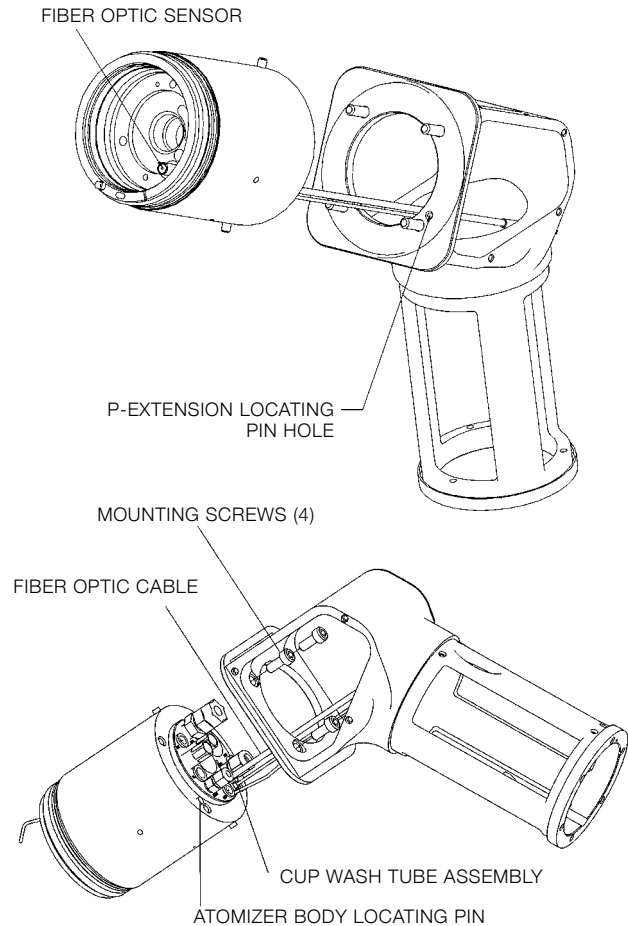

Figure 40: Installing Atomizer Body Assembly Onto Atomizer Extension

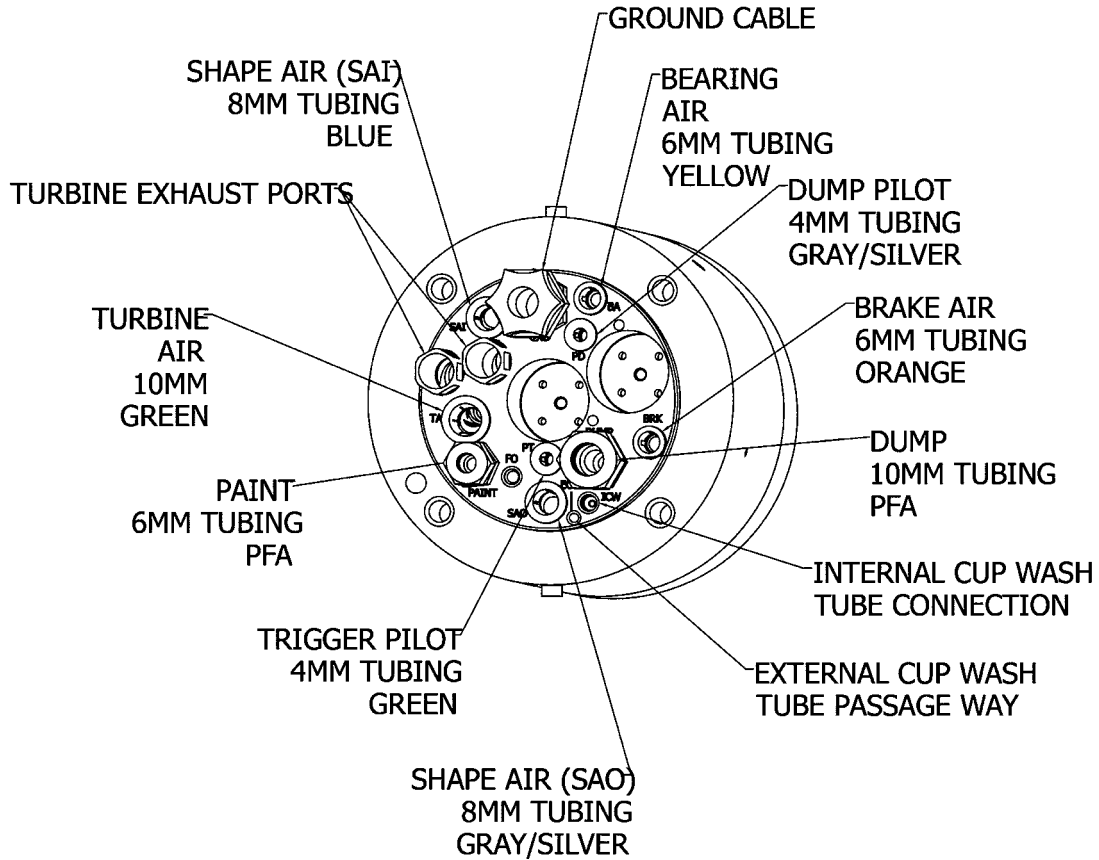

Figure 41: Atomizer Body Port Identification

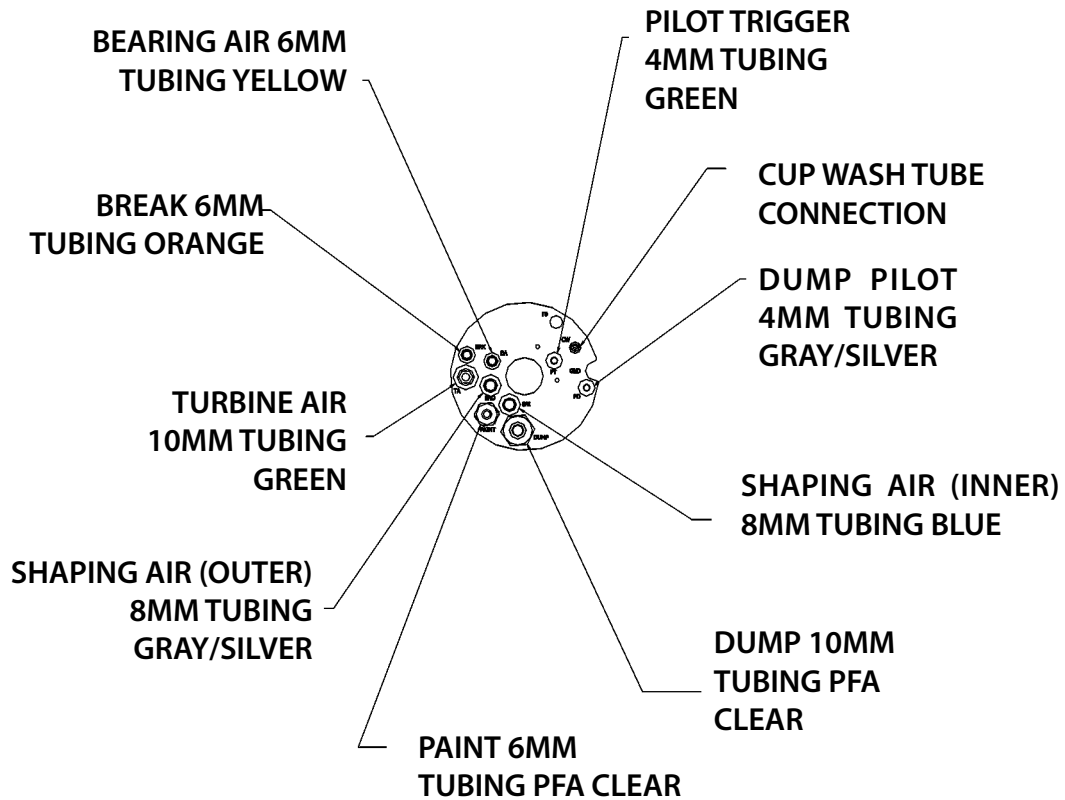

Figure 42: Cup Wash Manifold Port Identification

Valve and Seat Removal/ Installation (Cup Wash Manifold)

Using the valve removal tool (A11922-00), engage the four (4) pins on the tool to the corresponding four (4) hole pattern in the top of the valve. Using a 1/2-inch (13mm) socket, end wrench, or adjustable wrench, remove the valve by turning counter-clockwise.

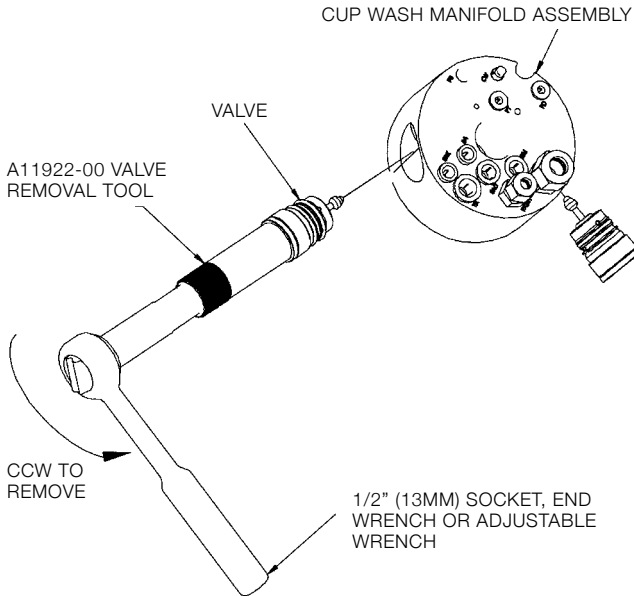

Figure 44: Valve Removal

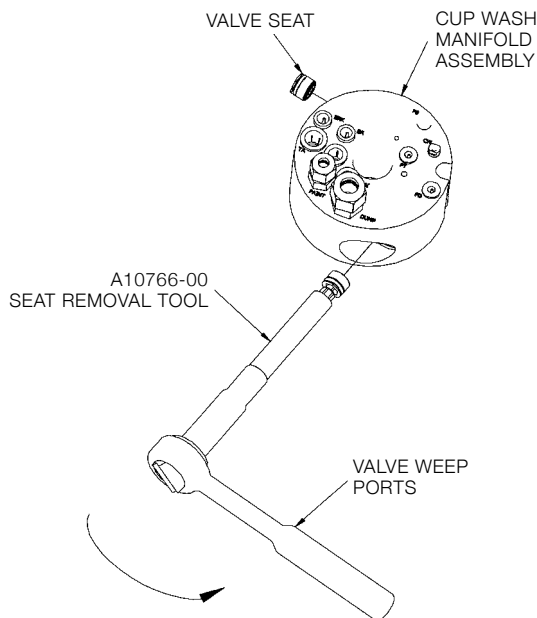

Figure 45: Seat Removal

Using the seat removal tool (A10756-00), insert the smaller hex end into the block to engage the seat hex. Using a 3/8-inch (10mm) socket, end wrench, or adjustable wrench, remove the seat by turning counter-clockwise.

Valve and Seat Inspection

Inspect the valves and seats for any build-up or leakage of materials. Valves should be cleaned with an appropriate cleaning solvent to remove the material on it.

NOTE

- A seat should not need to be replaced unless there are indications of valve leakage in operation.

Replacement

Lubricate the O-ring on the seat assembly using a suitable lubricant, then by hand, using the seat removal tool (A10766-00), carefully start the seat assembly into the pocket of the manifold.

NOTE

- Carefully start the seat assembly into the pocket. It may be easily cross threaded.

Hand tighten the seat in place. Using a torque wrench with a 3/8-inch (10mm) socket, torque the valve seats to 15-20 lbs.- in. (1.7-2.3 Nm).

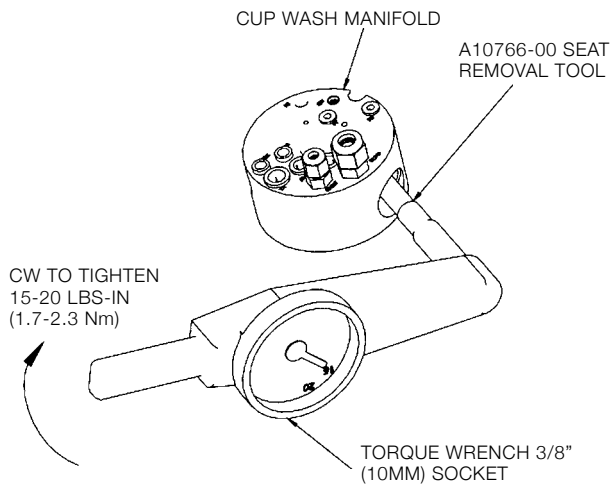

Figure 46: Valve Seat Torque

⚠ WARNING

➤ Always use a torque wrench to torque the seats in place. Over-torquing the seats may cause permanent irreparable damage to the manifold.

Lubricate the valve O-rings with a suitable O-ring lubricant. By hand, thread the valve into the pocket in a clockwise direction. Tighten using a 1/2-inch (13mm) socket and torque to 15-20 lbs.- in. (1.7-2.3 Nm) after valve is down.

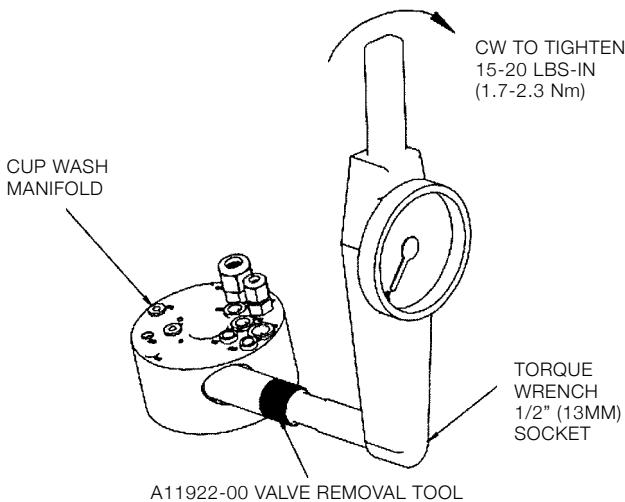

Figure 44: Valve Removal

Valve and Seat Removal (Atomizer Body End) (Figures 48 and 49)

Removal

Using the valve seat removal tool (A11922-00), engage the four (4) pins on the tool to the corresponding four (4) hole pattern in the top of the valve. Tighten knurled thumb screw and tool to engage 1-2 threads on the valve cap. This will aid in pulling the valve from its bore once it is loose.

Using a 1/2-inch (13mm) socket, remove the valve by turning clockwise until fully unthreaded. Pull the valve assembly from the pocket. Pull valve straight out.

Using seat removal tool (A10766-00), insert the smaller hex end into the valve cavity to engage the seat hex. Using a 3/8-inch (10mm) socket, remove the seat by turning counter-clockwise.

Replacement

Clean seat and valve pocket thoroughly. Lubricate valve pocket, O-rings on seat and valve assemblies with A11545-00 lubricant. Carefully start the seat assembly into the valve pocket. Hand tighten in place. Using a torque wrench with a 3/8-inch (10mm) socket, torque the valve seat to 15-20 lbs.- in. (1.73-2.3 Nm). Next place the valve onto the four prongs of the valve removal tool and insert into the valve pocket. Tighten by hand as far as possible. Tighten fully using a torque wrench with a 1/2-inch (13mm) socket and torque to 15-20 lbs.- in. (1.7-2.3 Nm) after valve is down.

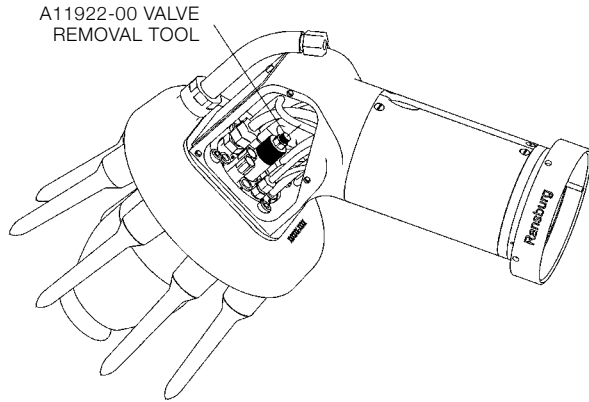

Figure 48: Valve Extraction

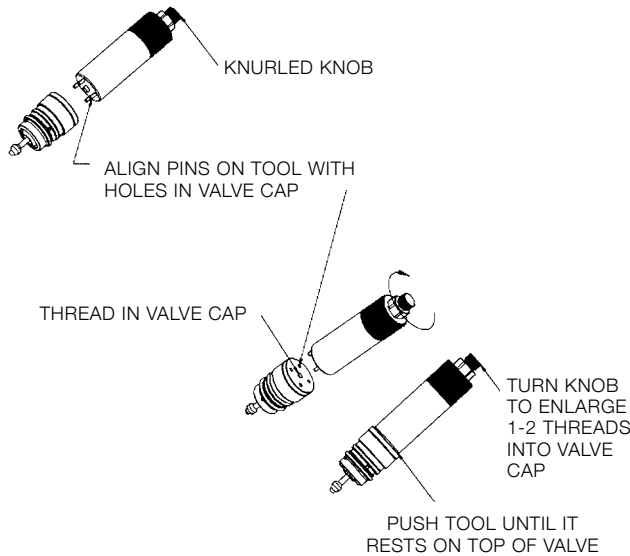

Figure 49: Valve Extraction

Fiber Optic Cable and Transmitter Removal/Replacement

Removal

Remove the atomizer body from the atomizer extension as discussed earlier.

Remove the fiber optic nut from the inside cavity where the air bearing spindle seats using the fiber optic transmitter tool (78279-00). Loosen and remove nut. Carefully pull out the fiber optic transmitter from the front while pushing the cable from the opposite end. Loosen the black knurled nut holding the cable to the transmitter. Pull the

nut off of the cable. The cable can be pulled out from the back side of the atomizer body.

Replacement

To replace, slide the new fiber optic cable through the hole in the back side of the atomizer body until it protrudes well out in front of the body. Slide the black knurled nut over the fiber optic cable approximately 1/4-inch (onto the black portion of the cable). Install the glass fiber portion into the rear of the transmitter until it bottoms. Slide the nut forward and tighten securely. Slide the entire assembly back into the atomizer body. Pull gently from the back side while pushing the transmitter from the front. Slide fiber optic nut over transmitter and tighten securely with transmitter tool (78279-00). Feel transmitter after installation. It should not be loose when properly installed.

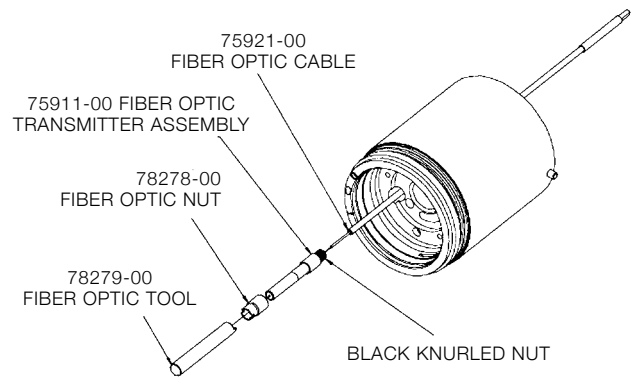

Figure 50: Fiber Optic Removal/Replacement

Quick Release Collet Removal/Replacement

(Atomizer Body And Cup Wash Manifold) (Figure 51)

If collet or O-rings become damaged, they can be removed and replaced. To remove the collet, use a flat blade screwdriver or needle nose pliers. If using the screwdriver, lift collet with fingers and place screwdriver blade under the head. Pry up in several places if necessary until removed. If using the pliers, grasp the head between the inside and outside diameter and pull straight out or by pulling with a rocking motion.

Remove the O-ring with a plastic pick device. Do not scratch or nick the sealing surfaces.

To replace O-ring and collet, lubricate the O-ring with petroleum jelly and insert into hole and make sure it lies flat on its seating surface. Align the collet with the hole and push straight in. Some collets are tighter than others by design and may require a rocking motion while pushing.

This procedure is the same for all the collets, in the atomizer body, and the cup wash manifold.

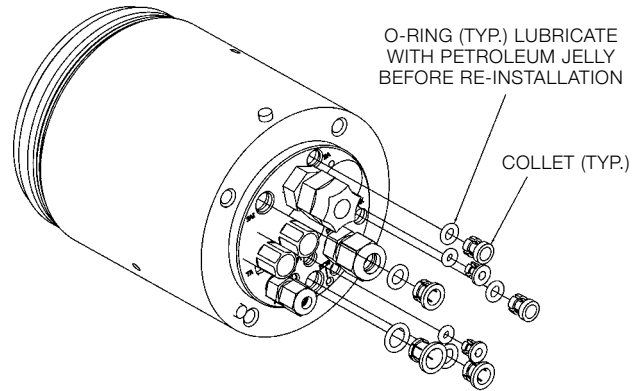

Figure 51: Collet and O-Ring Removal/Replacement

Turbine O-Ring Replacement (Figure 52)

Remove air bearing turbine from the atomizer.
 Remove all exterior O-rings.
 Lightly lubricate all O-rings with A11545 Petrolatum jelly before reinstalling.
 Kit A11534-01 contains all required O-rings for replacement.

NOTE

➤ Turbine assemblies are field repairable after the initial one year warranty period. Consult a Ransburg representative for proper manuals and training before attempting any repairs. Any attempt to repair the turbine before the one year warranty period has expired will void the warranty.

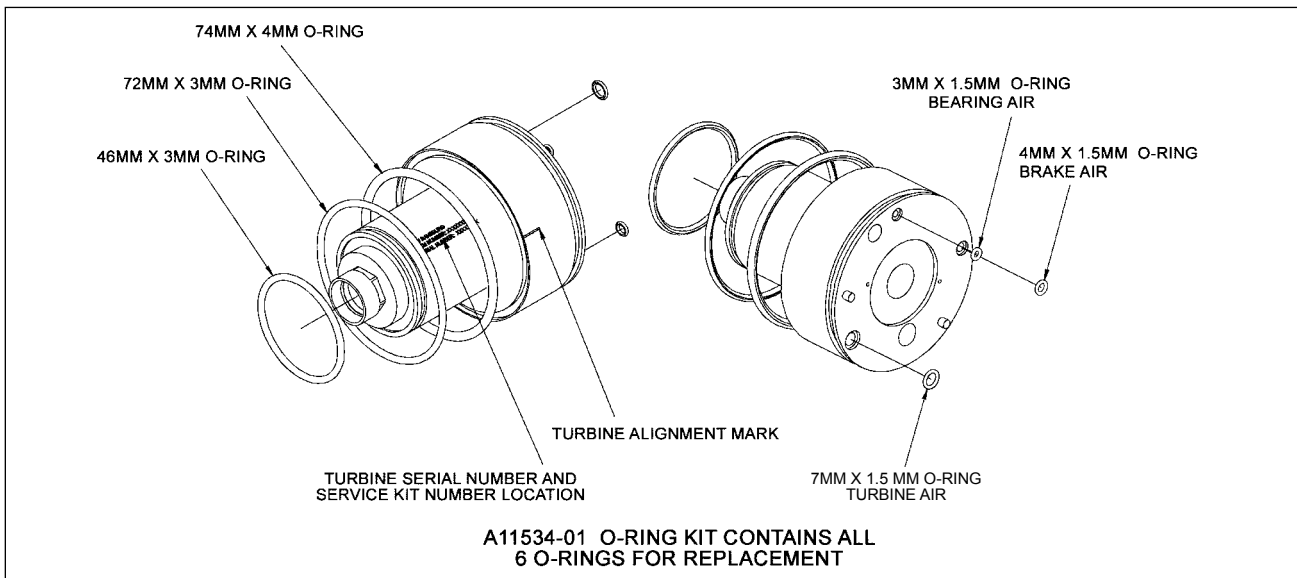

Figure 52: Turbine O-Ring Replacement

TURBINE REBUILD MANUAL		
Turbine Part No.	Manual	Description
A12895-01	SI-12-02.1	SILVER SHAFT
A12895-04	SI-13-02	BLACK SHAFT

CHECKING PROBES

Check atomizer voltage using the Ransburg Test Meter Kit (76652-01 or 76652-04). Verify that the output voltages have not varied much from the setup standard. A drastic change in voltage can be an early indicator of a component or system problem. The data shown was collected under the ideal lab conditions using a clean atomizer and an unloaded fluid delivery system.

The following data is for use with the RMA-570. The output voltage measured at the bell will normally range between 91% and 97% of the kV set point displayed at the control unit. Typically setting for spraying is 70 kV.

High Voltage Ring Inspection

Examine entire ring for burning marks indicated by melted plastic or blackened areas around or near where the electrodes are located, the area where the high voltage input tube is, and on the inner diameter of the ring.

If any area is found with the above conditions, the ring must be replaced.

After verifying, clean all old dielectric grease from the eight (8) protrusions on the front of the ring and from the concentric circles at the high voltage input protrusion.

Reapply dielectric grease (LSCH0009) to both of these areas. The eight (8) protrusions only require a thin film of grease. The high voltage input area must be filled with grease allowing no air voids. Excess grease will be squeezed out when the input tube and high voltage cable are installed. Wipe off all excess grease.

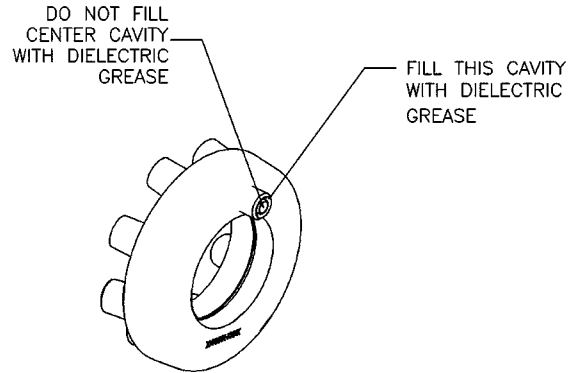

Figure 53: High Voltage Ring Lubrication

ELECTRODE RESISTANCE TEST

To verify that all indirect charge electrodes are functioning, place one lead of a Yokogama megohm meter or equivalent to the metal contact at the base of the electrode and the other end to the small metal wire at the tip of the electrode. Refer to the “Electrode Assembly Resistance Reading” chart in this section for the proper resistance reading for the electrode assembly.

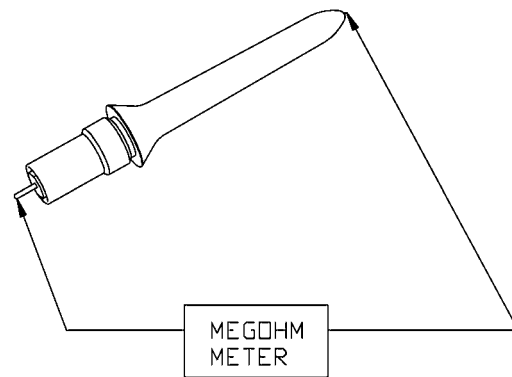

Figure 54: Turbine O-Ring Replacement

ELECTRODE ASSEMBLY RESISTANCE READING		
Part No.	Resistance Reading (Megohms)	Used At (Locations)
A11343-02	209-231	Sea Level
A11343-03	129-151	Above 5,000 ft.

If reading falls out of this range, disassemble electrode assembly and check reading of resistor only. If reading is in the acceptable range, discard the electrode body (A11342-00) and replace with a new one. Rebuild electrode assembly as follows: apply a small amount of dielectric grease to each end of the resistor, slide resistor into the electrode body (A11342-00). Install the contact assembly after the resistor. Finally, apply a small amount of dielectric grease to contact area of plunger contact assembly. Thread plunger contact assembly into electrode body by hand until it stops. Hand tight is good enough. Over-tightening will damage the electrode body (see Figure 55).

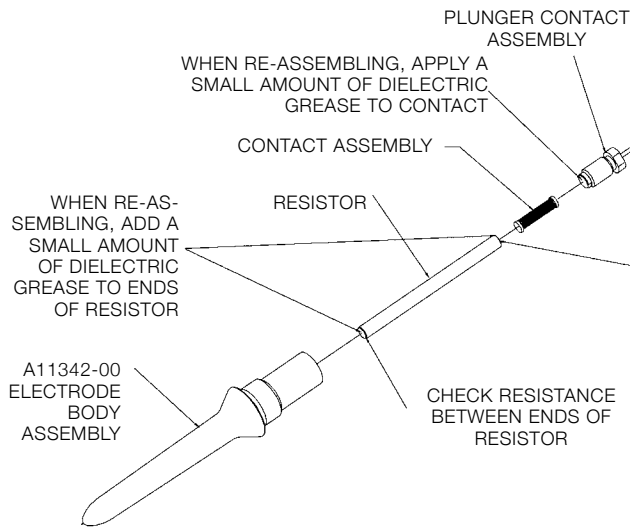

Figure 55: Disassembly/Assembly Electrode Assembly

Before Installing a New or Used Electrode into the High Voltage Ring

Replace the dielectric grease in the area as shown in Figure 56. A thin film is all that is required.

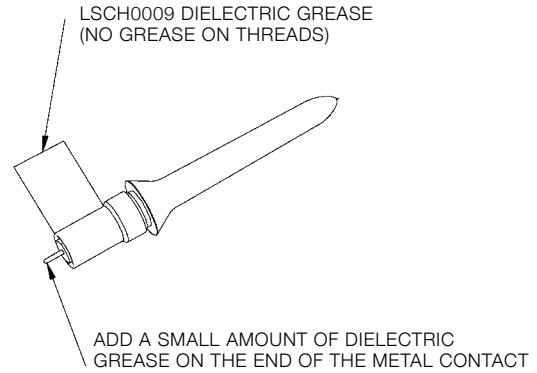

Figure 56: Replacing Dielectric Grease

Electrode Tip Inspection

Inspect the electrode tips weekly or sooner. If a collision has occurred, immediate inspection is required. The tip of the electrode should be sharp and pointed. After time, the tip will wear. If the tip is rounded or worn jagged it must be replaced. Depending on use, electrode tips will last 3-6 months. The electrostatic fields generated by these electrodes are very important to maintain paint transfer efficiency, pattern uniformity, and atomizer cleanliness.

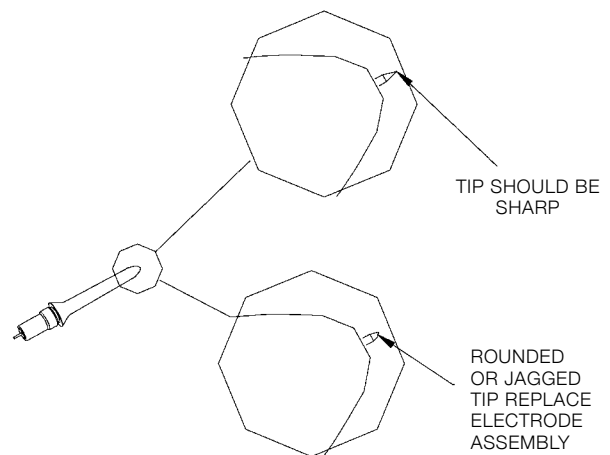

Figure 57: Inspection of Electrode Tip

OPERATOR / MAINTENANCE *WARNINGS*****

DO NOT attempt to hold a rag or a gloved hand against the bell edge to stop or slow down a rotating bell.

DO NOT attempt to clean the bell edge while the bell is rotating.

DO NOT attempt to use sharp or abrasive materials to clean the bell, which will scratch or damage the bell.

DO NOT attempt to place a high voltage probe on the bell edge unless rotation is full stopped.

DO NOT reuse an atomizer bell that shows signs of damage such as nicks, heavy scratches, dents, or excessive wear (defined under “Bell Cup Cleaning” in the “Maintenance” section).

TUBING BUNDLE ASSEMBLY FITTING INSTALLATION AND TUBING REPAIR

NOTE

1. Petrolatum jell required to aid in installation
2. Screw driver for repair
3. Sharp blade for cutting tubing
4. Nitrile or latex gloves to grip components
5. Adjustable wrench and flat plate for installation aid

To Install:



Install receiver over tube first, then lightly lubricate the beginning of the barb of the fitting. Push fully into tube.



Lightly lubricate O.D. of tubing.



Push receiver fully over tubing and barb assembly.

To Remove:



Insert screwdriver into slot.

To Remove (Cont.):



Pry apart until receiver is separated from barb and tube assembly



Cut off damaged tubing and follow installation instructions.



Cut tube from barb and remove tubing.

TROUBLESHOOTING GUIDE

General Problem	Possible Cause	Solution
<p>Bad Spray Pattern</p>	Bell cup damaged	Replace bell cup.
	Low voltage	See “Low or No High Voltage” below.
	Paint lodged in shaping air ring	Disassemble and clean (see “Maintenance” section).
<p>Low or No High Voltage</p>	High current draw	Check resistance of electrodes.
	MicroPak controller cascade	Inspect low voltage at the MicroPak and the cascade. a. Faulty low voltage cable.
	Improperly mounted air turbine	Verify ground connection of air turbine to earth ground at less than 1 megohm.
	Faulty low voltage connections (usually indicated by MicroPak feedback fault light)	a. Make sure quick disconnection electrical connection is aligned and clean. b. Check low voltage connection at cascade.
	Faulty high voltage connection	Verify that high voltage cable is fully seated in the cascade and the high voltage ring.
	MicroPak or cascade failure	Refer to current MicroPak manual for detailed Troubleshooting Guide.
	MicroPak settings not correct	Refer to current “MicroPak” manual for detailed “Troubleshooting Guide.”
	Damaged high voltage cable	Remove and inspect/measure resistance.
	Dielectric breakdown of high voltage parts	Check cascade, high voltage ring, and high voltage cable. Replace defective parts.
Improper color change (i.e., paint or solvent in dump line)	Optimize color change.	
<p>Low Transfer Efficiency (or light coverage)</p>	Low or no high voltage	Verify high voltage at electrodes. Normally, a high voltage setting of 30-70 kV is appropriate for most applications.
	Poor grounding of parts being coated	Verify that parts being coated are properly grounded (the electrical resistance between the part and ground must not exceed 1 megohm).

TROUBLESHOOTING GUIDE (Cont.)

General Problem	Possible Cause	Solution
<p>Low Transfer Efficiency (or light coverage) (Cont.)</p>	<p>3. Excessive turbine speed</p>	<p>3. For optimum transfer efficiency and spray pattern control, the bell rotational speed should be set at the minimum required to achieve proper atomization of the coating material.</p>
	<p>4. Excessive robot speed</p>	<p>4. For optimum transfer efficiency, spray pattern control, bell speed, and robot speed should be set at the minimum to achieve desired results of part to be coated.</p>
	<p>5. Excessive inner/outer shaping air</p>	<p>5. Shaping air should be set at the minimum volume required to gently direct the spray pattern toward the part being coated. Excessive shaping air will cause some atomized particles to “blow-by” the part or bounce back onto the atomizer.</p>
	<p>6. Excessive target distance</p>	<p>6. The recommended target distance is between 6 and 12-inches (152.4-304.8mm) (see “Target Distance” in the “Operation” section of this manual).</p>
<p>No Turbine Air</p>	<p>1. Turbine drive air not present</p>	<p>1. Verify supply air pressure.</p>
	<p>2. Bearing air return signal not present</p>	<p>2. a. Verify bearing air return signal. b. Increase bearing air supply pressure to 90 psig (±10 psig) (620.5 +/- 69 kPa).</p>
	<p>3. Brake air is activated</p>	<p>3. Remove brake air signal (turbine air and brake air must be interlocked to prevent both from being used simultaneously).</p>
<p>Speed Feedback Fault</p>	<p>Damaged fiber optic cable between robot plate and control panel</p> <p>Connection at robot or bell plate is loose</p> <p>Fiber optic transmitter failure</p> <p>Bad transceiver module</p> <p>Excessive vibration</p>	<p>a. Repair or replace fiber optic cable. b. Bad splice connection or too many splices. Maximum three (3) splices permitted.</p> <p>Re-install cable and tighten locking set screw.</p> <p>Replace fiber optic transmitter.</p> <p>Replace transceiver module.</p> <p>a. Check bell cup for damage b. Check bell cup for excessive paint buildup c. Insure bell cup is tightened properly d. Check cup and shaft tapers for cleanliness</p>

TROUBLESHOOTING GUIDE (Cont.)

General Problem	Possible Cause	Solution
<p>No Fluid Flow</p>	<p>Turbine is not rotating</p>	<p>Verify rotation of turbine (the paint valve air pilot must be interlocked with the turbine speed feed back signal to ensure that paint does not flow into the air bearing).</p>
	<p>Fluid valve does not actuate</p>	<p>a. Verify that air pilot signal is present. b. Fluid valve air pilot pressure is too low. Increase air pressure to 70 psig minimum. c. Replace fluid valve.</p>
	<p>Clogged fluid tube/fluid tip</p>	<p>Remove and inspect fluid tube or fluid tip.</p>
	<p>Bad transceiver module</p>	<p>Replace transceiver module.</p>
<p>Continuous Fluid Flow</p>	<p>Fluid valve open</p>	<p>a. Remove air pilot signal. b. If still open, replace fluid valve.</p>
	<p>Fluid valve seat damaged or worn</p>	<p>Replace fluid valve seat.</p>
<p>Uncontrollable Fluid Flow</p>	<p>Insufficient back pressure to fluid regulator</p>	<p>Replace fluid tip with the next smaller inner diameter size.</p>
	<p>Fluid regulator does not control flow (system)</p>	<p>Disassemble fluid regulator and inspect for failed components (system).</p>
<p>Fluid and/or Air Leakage Between the Robot and Bell Manifold Plates</p>	<p>Atomizer mounting ring is loose</p>	<p>Tighten mounting ring.</p>
	<p>O-ring is missing</p>	<p>Install O-ring.</p>
	<p>O-ring is damaged</p>	<p>Visually inspect for damage and replace</p>
<p>Fluid Leakage In Fluid Manifold or Bell Plate</p>	<p>O-ring is damaged</p>	<p>Replace O-ring.</p>
	<p>Fluid tubing not properly installed or tightened.</p>	<p>Inspect and retighten.</p>
<p>Fluid Leakage Around Fluid Valve</p>	<p>Damaged o-ring(s) on outer diameter of valve body</p>	<p>Replace o-ring(s).</p>
	<p>Damaged or worn needle seals inside valve assembly</p>	<p>Replace valve assembly.</p>

TROUBLESHOOTING GUIDE (Cont.)

General Problem	Possible Cause	Solution
Turbine Cannot Attain Desired Speed	Excessive vibration	a. Check bell cup for damage b. Check bell cup for excessive paint buildup c. Bell cup loose - tighten to proper torque d. Check cup and shaft tapers for cleanliness e. Have manufacturing check bell cup balance
	Low or no bearing air	a. Check bearing air pressure (minimum 80 psi) (352 kPa) b. Check filters for contamination c. Check for bent or damaged bearing air line d. Poor turbine air pressure - plant air e. Damaged speed control cards
	Loss of fiber optic/no feed back	Damaged fiber optic sensor, bad cable, too many splices. Maximum three (3) splices permitted.
Loss of Exterior/ Interior Cup Wash or Lack of Flow	Bent or kinked supply tube	Replace
	No fluid flow	Check microvalve, check fluid supply source
	Blocked fluid tip or external nozzle	Clean parts, remove obstruction
	Ferrules holding tubing over-tightened	Replace tubing and ferrule assembly
Paint or overspray collecting on probes, shroud and shape air components	Wet surfaces	Clean and dry parts thoroughly after cleaning.
	Conductive surface	After cleaning, wipe with non polar solvent such as VM&P NAPHTHA and dry thoroughly.
	Shape air pressure too low	Adjust air pressure or flow to give more forward velocity.
	Robot speed to fast for pattern size	Slow robot speed or adjust pattern air pressure or flow to eliminate "brooming" effect.
	No target in front of applicator when paint and voltage are turned on	Trigger paing on when target is in front of applicator, trigger H.V. off last after shutting paint off.

PARTS IDENTIFICATION

RMA-570 INDIRECT CHARGE ROTARY ATOMIZER MODEL IDENTIFICATION

When ordering, use A13365-ABCDE and F as indicated by Tables A, B, C, D, E and F. Nine (9) digits must follow the basic part number.

For Example:

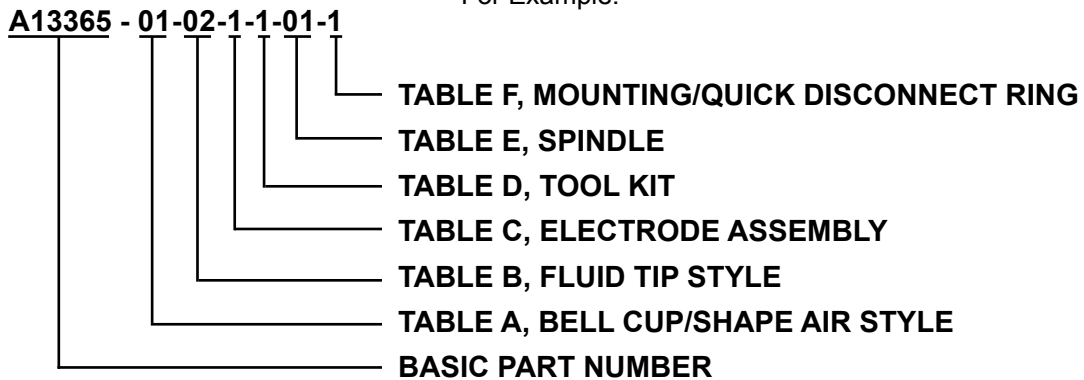

* Model number and serial number of the atomizer is located on the face of the rear plate assembly.

TABLE A - BELL CUP/SHAPE AIR STYLE			
Dash #	A	B	Description
01	A12900-00	A12874-07	65MM MONO FLEX SERRATED TITANIUM (TISF)
02	A12900-00	A12874-10	65MM DUAL FLEX SERRATED TITANIUM (TISF)
03	A12900-01	A12874-07	65MM MONO FLEX NON-SERRATED TITANIUM (TIF)
04	A12900-01	A12874-10	65MM DUAL FLEX NON-SERRATED TITANIUM (TIF)
05	A12900-00	A12874-11	65MM DUAL FLEX SERRATED TITANIUM (TISF) (PTFE SHROUD)
06	A12900-01	A12874-11	65MM DUAL FLEX NON-SERRATED TITANIUM (TIF) (PTFE SHROUD)
07	A13114-00	A12874-13	55MM DUAL FLEX SERRATED TITANIUM (TISF)
08	A13114-01	A12874-13	55MM DUAL FLEX NON-SERRATED TITANIUM (TIF)
09	A12900-02	A12874-07	65MM MONO FLEX SERRATED TITANIUM (TISF) LONG LIFE SPLASH PLATE
10	A12900-03	A12874-07	65MM MONO FLEX NON-SERRATED TITANIUM (TIF) LONG LIFE SPLASH PLATE
11	A12900-02	A12874-10	65MM DUAL FLEX SERRATED TITANIUM (TISF) LONG LIFE SPLASH PLATE
12	A12900-03	A12874-10	65MM DUAL FLEX NON-SERRATED TITANIUM (TIF) LONG LIFE SPLASH PLATE
13	A12900-04	A12874-07	65MM MONO FLEX SERRATED ALUMINUM (ALSF) PLASTIC SPLASH PLATE
14	A12900-05	A12874-07	65MM MONO FLEX NON-SERRATED ALUMINUM (ALF) PLASTIC SPLASH PLATE
15	A12900-04	A12874-11	65MM DUAL FLEX SERRATED ALUMINUM (ALSF) (PTFE SHROUD) PLASTIC SPLASH PLATE
16	A12900-05	A12874-11	65MM DUAL FLEX NON-SERRATED ALUMINUM (ALF) (PTFE SHROUD) PLASTIC SPLASH PLATE
17	A12900-04	A12874-10	65MM DUAL FLEX SERRATED ALUMINUM (ALSF) PLASTIC SPLASH PLATE
18	A12900-05	A12874-10	65MM DUAL FLEX NON-SERRATED ALUMINUM(ALF) PLASTIC SPLASH PLATE
19	A12900-00	A13858-01	65MM MONO FLEX SERRATED TITANIUM (TISF) PLASTIC SPLASH PLATE, ALL PTFE EXTENDED SHROUD & SHAPE AIR PARTS
20	A12900-01	A13858-01	65MM MONO FLEX NON-SERRATED TITANIUM (TIF) PLASTIC SPLASH PLATE, ALL PTFE EXTENDED SHROUD & SHAPE AIR PARTS
21	A12900-02	A13858-01	65MM MONO FLEX SERRATED TITANIUM (TISF) LONG LIFE SPLASH PLATE, , ALL PTFE EXTENDED SHROUD & SHAPE AIR PARTS
22	A12900-03	A13858-01	65MM MONO FLEX NON-SERRATED TITANIUM (TIF) LONG LIFE SPLASH PLATE, ALL PTFE EXTENDED SHROUD & SHAPE AIR PARTS
23	A12900-00	A13858-02	65MM DUAL FLEX SERRATED TITANIUM (TISF) PLASTIC SPLASH PLATE, ALL PTFE EXTENDED SHROUD & SHAPE AIR PARTS
24	A12900-01	A13858-02	65MM DUAL FLEX NON-SERRATED TITANIUM (TIF) PLASTIC SPLASH PLATE, ALL PTFE EXTENDED SHROUD & SHAPE AIR PARTS
25	A12900-02	A13858-02	65MM DUAL FLEX SERRATED TITANIUM (TISF) LONG LIFE SPLASH PLATE, ALL PTFE EXTENDED SHROUD & SHAPE AIR PARTS
26	A12900-03	A13858-02	65MM DUAL FLEX NON-SERRATED TITANIUM (TIF) LONG LIFE SPLASH PLATE, ALL PTFE EXTENDED SHROUD & SHAPE AIR PARTS

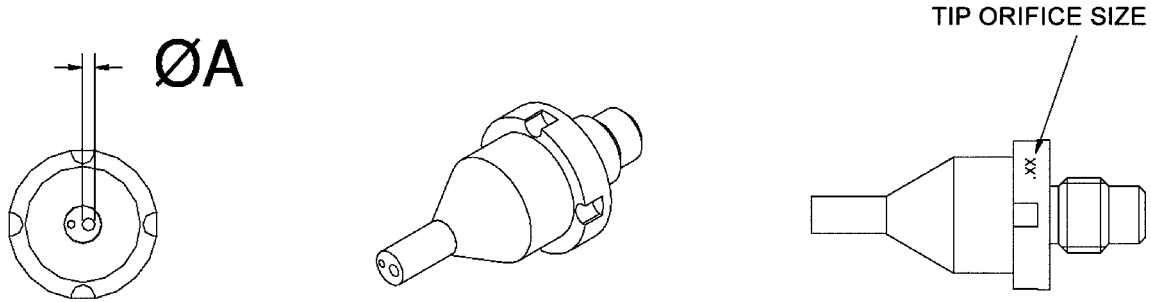

Figure 58: Fluid Tip Sizes

TABLE B - FLUID TIP SELECTION		
Dash No.	E	Description
01	A11240-01	.028" / 0.7 MM OPENING
02	A11240-02	.035" / 0.9 MM OPENING
03	A11240-03	.043" / 1.1 MM OPENING
04	A11240-04	.047" / 1.2 MM OPENING
05	A11240-05	.062" / 1.6 MM OPENING
06	A11240-06	.039" / 1.0 MM OPENING

TABLE C - HIGH VOLTAGE RING/ELECTRODE ASSEMBLY			
Dash No.	F	Description	For Use at Locations
01	A11343-02	8 PROBE, 220 MEGOHM RESISTOR	AT SEA LEVEL
02	A11343-03	8 PROBE, 140 MEGOHM RESISTOR	ABOVE 5000 FT. SEA LEVEL

TABLE D - TOOL KIT		
Dash No.	G	Description
01	--	NONE
02	A12090-02	TOOL KIT

TABLE E - SPINDLE			
Dash No.	H	Description	Note
00	NONE	NONE	
01	A12895-01	SPINDLE	SPINDLE ASSEMBLY - SILVER SHAFT
02	A12895-04	SPINDLE	SPINDLE ASSEMBLY - BLACK SHAFT

TABLE F - MOUNTING/QUICK DISCONNECT RING		
Dash No.	C	Description
01	A11201-00	MOUNTING RING - STAINLESS STEEL
02	A13455-00	MOUNTING RING - PLASTIC WITH SKIRT

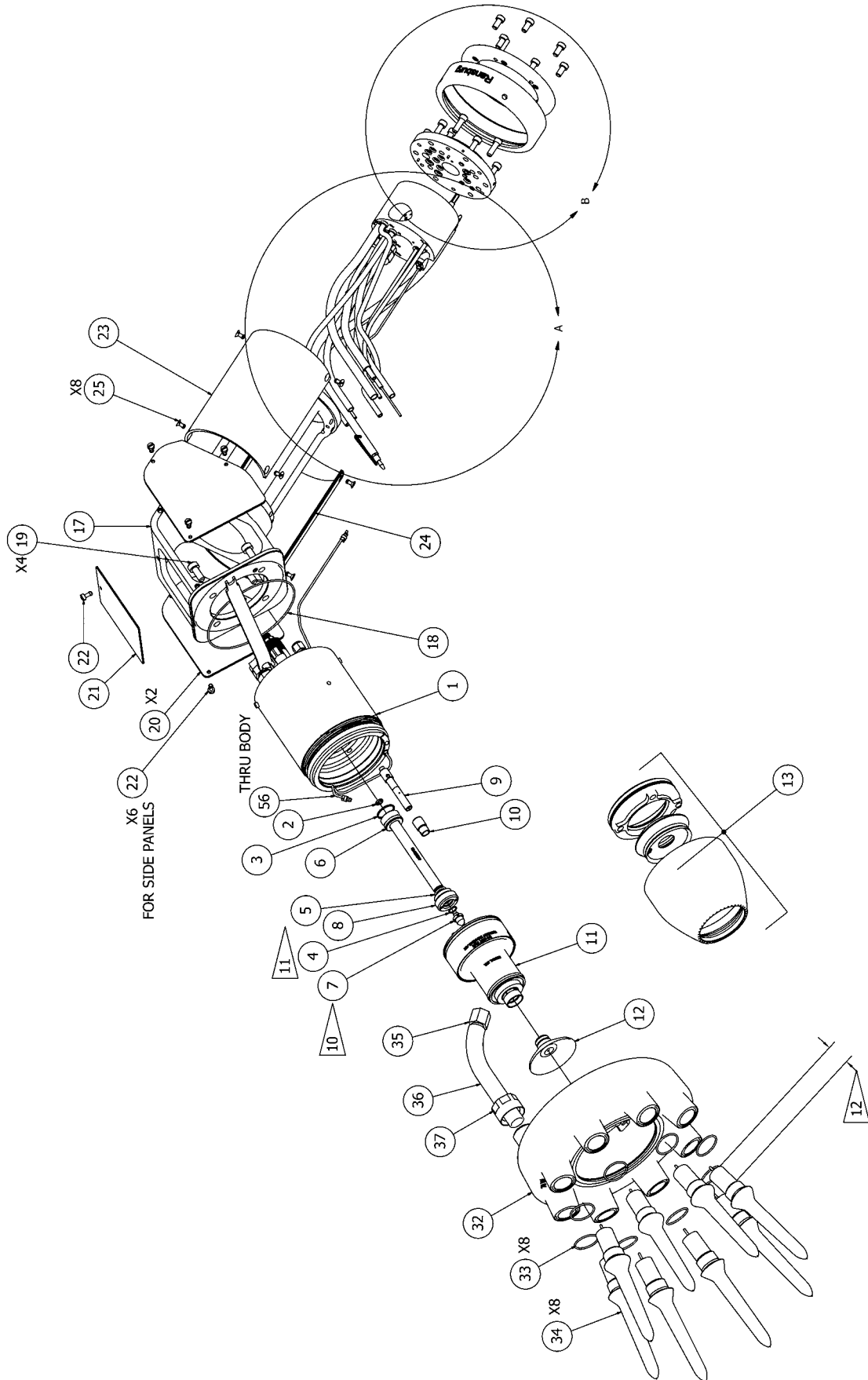

Figure 59a: RMA-570 Assembly

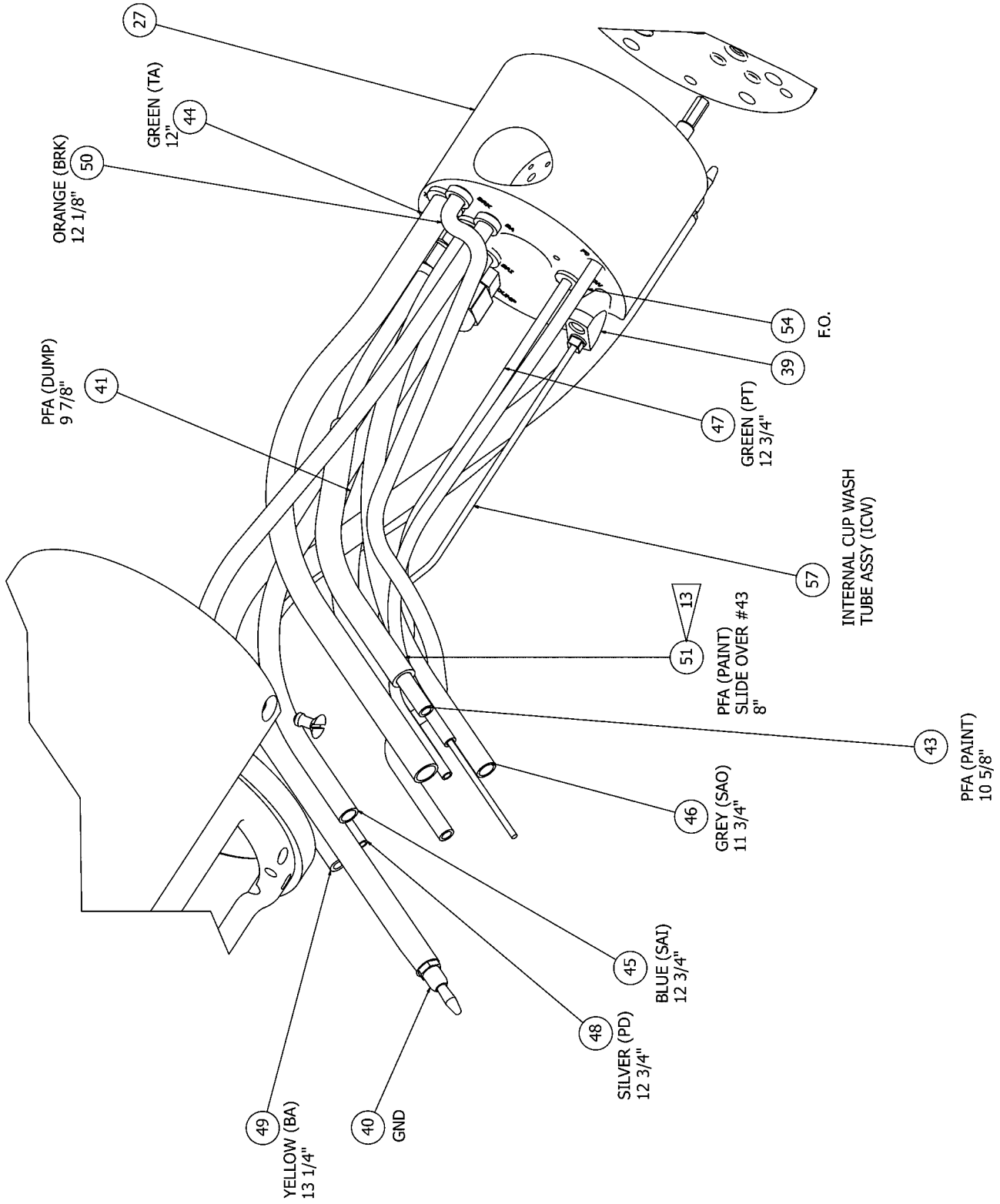
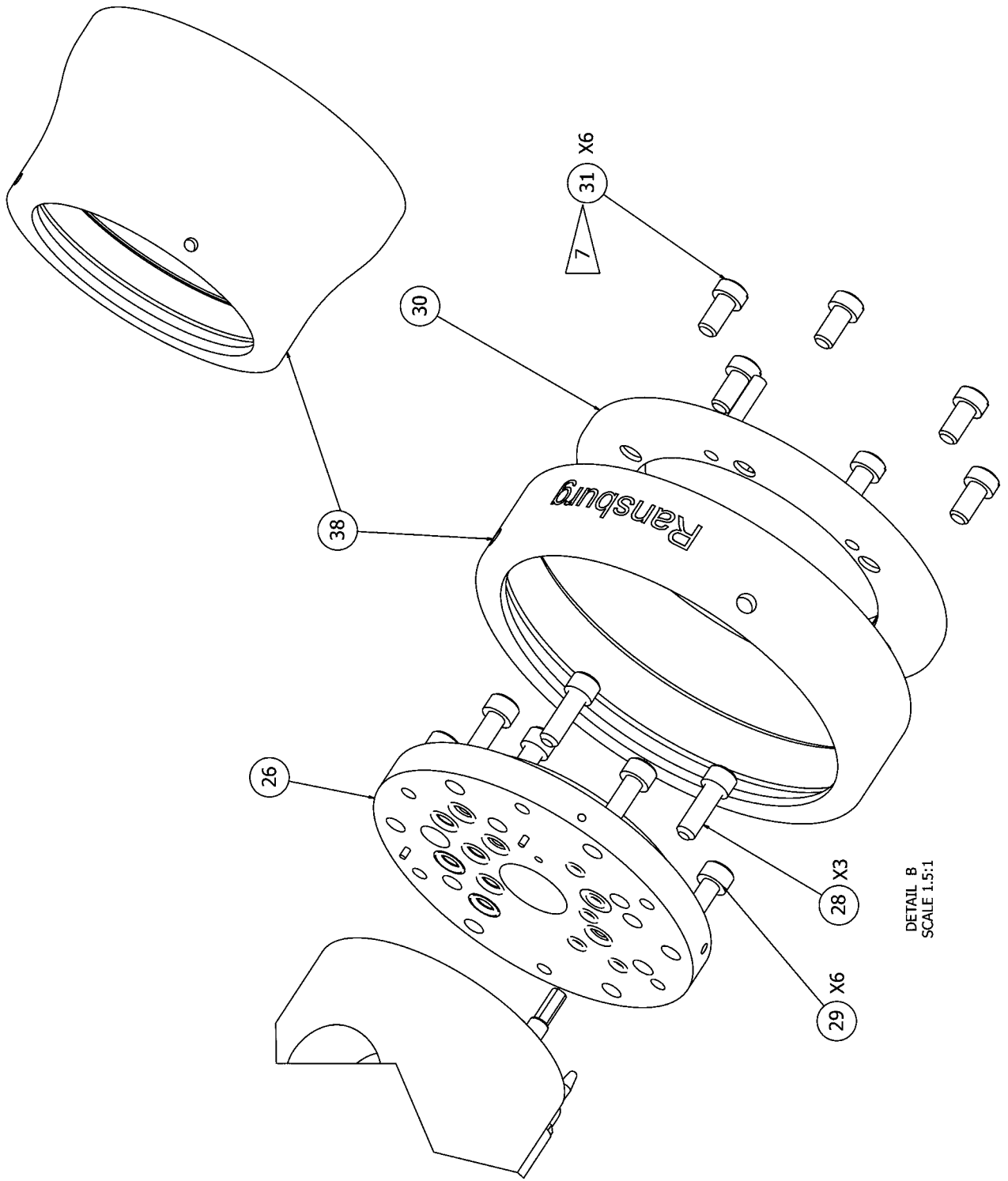

Figure 59b: RMA-570 Assembly



A13365 ASSEMBLY - PARTS LIST (Figure 59a & 59b)				
Item	Qty	Part #	Description	Where Used
1	1	A13451-01	APPLICATOR MOUNTING ASSEMBLY (INDIRECT)	
2	1	79001-40	O-RING, SOLVENT PROOF	FLUID TUBE ASSEMBLY
3	1	79001-41	O-RING, SOLVENT PROOF	FLUID TUBE ASSEMBLY
4	1	79001-44	O-RING, SOLVENT PROOF	FLUID TIP
5	1	79001-42	O-RING, SOLVENT PROOF	FLUID TUBE RETAINER
6	1	A13535-00	FLUID TUBE ASSEMBLY	
7	1	"E"	FLUID TIP	
8	1	A11226-00	RETAINER, FLUID TUBE	
9	1	75911-00	ASSEMBLY, FIBER OPTIC TRANSMITTER	
10	1	78278-00	NUT, FIBER OPTIC TENSIONING	
11	1	"H"	SPINDLE	
12	1	"A"	BELL CUP ASSEMBLY	
13	1	"B"	SHAPING AIR KIT	
17	1	A11685-01	ATOMIZER P-EXTENSION	
18	1	LSOR0005-15	O-RING, PFA ENCAPSULATED (2-048)	H.V. RING REAR FACE TO P. EXT.
19	4	A11338-00	SCREW, SOC HD CAP M8 X 25MM LG, G10 FIBERGLASS	P. EXT TO APPLICATOR MOUNTING ASSY.
20	2	A11687-01	COVER	
21	1	A11686-01	TOP COVER	
22	7	A11682-01	SCREW, CAPTURED	SIDE, TOP COVERS
23	1	A11689-01	REAR SHROUD (LEFT HALF)	
24	1	A11688-01	REAR SHROUD (RIGHT HALF)	
25	8	A11690-01	SCREW, CAPTURED	
26	1	A13453-00	REAR PLATE ASSEMBLY (INDIRECT)	
27	1	A11692-00	SOLVENT/AIR CHOP MANIFOLD ASSEMBLY	
28	3	76566-24C	SCREW, STAINLESS 1/4-20 X 3/4 LG. S.H.C.S.	REAR PLATE TO VALVE MANIFOLD
29	6	A10468-20	SCREW, SHCS M6 X 1.0 X 16MM, SS	REAR PLATE TO P. EXT.
30	1	A11315-00	BREAKAWAY RING	
31	6	7683-16C	SCREW 1/4-20 STAINLESS STEEL	BREAKAWAY RING
32	1	A12079-00	HIGH VOLTAGE RING ASSEMBLY (8 PROBE)	
33	8	79001-45	O-RING SOLVENT PROOF)	HIGH VOLTAGE RING/ELECTRODE
34	8	"F"	ELECTRODE ASSEMBLY	
35	1	78441-00	FERRULE NUT, 3/8" OD, NYLON	
36	1	A11691-00	HIGH VOLTAGE TUBE	
37	1	A11318-00	HIGH VOLTAGE TUBE NUT	
38	1	"C"	RING, QUICK DISCONNECT	
39	1	A11894-00	FITTING, SOLVENT Y	VALVE MANIFOLD
40	1	A11696-00	GROUND WIRE ASSEMBLY	
41	9 7/8"	A10841-01	TUBING, PFA 10MM X 8MM	DUMP
43	10 5/8"	A10841-03	TUBING, PFA 6MM X 4MM	PAINT
44	12"	A10839-06	TUBING, NYLON, GREEN, 10MM X 8MM	TA
45	12 3/4"	A10893-07	TUBING, NYLON, BLUE, 8MM X 6MM	SAI
46	11 3/4"	A10893-04	TUBING, NYLON, GRAY, 8MM X 6MM	SAO
47	12 3/4"	77536-03	TUBING, NYLON, GREEN, 4MM X .106	PT
48	12 3/4"	77536-06	TUBING, NYLON, SILVER, 4MM X .106	PD
49	13 1/4"	A10840-08	TUBING, NYLON, YELLOW, 6MM X 4MM	BA
50	12 1/8"	A10840-09	TUBING, NYLON, ORANGE, 6MM X 4MM	BRK
51	8"	76698-04	TUBING, PFA, 3/8 X 1/4	PAINT (OVER JACKET)
54	1	75921-01	FIBER OPTIC CABLE ASSEMBLY	
56	1	A11351-04	CUP WASH TUBING ASSEMBLY	EXTERNAL CUP WASH
57	1	A11351-03	CUP WASH TUBING ASSEMBLY	INTERNAL CUP WASH (ICW)
60	1	"G"	TOOL KIT (NOT SHOWN)	
61	1	77141-20	LITERATURE KIT (NOT SHOWN)	

10
11

7

13
9

* Customer must verify spindle part number located on the outer housing, see page 13.

Parts list bullet definitions:

- 13 Slide item #51 over item #43 before installing nut and ferrules on item #43. After assembly and tightening of nuts and ferrules, slide item #51 up against nut at rear most portion of atomizer assembly.
- 12 Lightly coat this area with LSCH0009-00 dielectric grease.
No grease on threads.
- 11 Torque fluid tube assembly into atomizer body using A11229-00 tool to 65-75 lbs./in. (7.3 - 8.4 Nm)
- 10 Torque fluid tip using A11229-00 tool to 25-30 lbs./in. (2.8 - 3.4 Nm)
- 9 Tighten set screw in rear plate in rear plate for fiber optic to 5-10 lbs./in. torque (.56 - 1.3 Nm)
- 8 Lubricate all o-rings with Amojell sparingly to aid in installation.
- 7 Tighten the break-away mounting ring screws alternately to a final torque reading of 10-15 lbs./in. (1.13 -1.70 Nm)

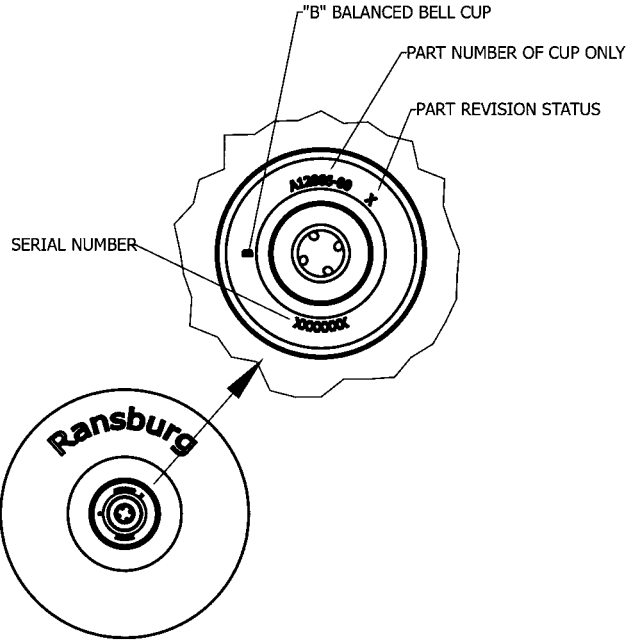

Bell Cup Part Number / Serial Number

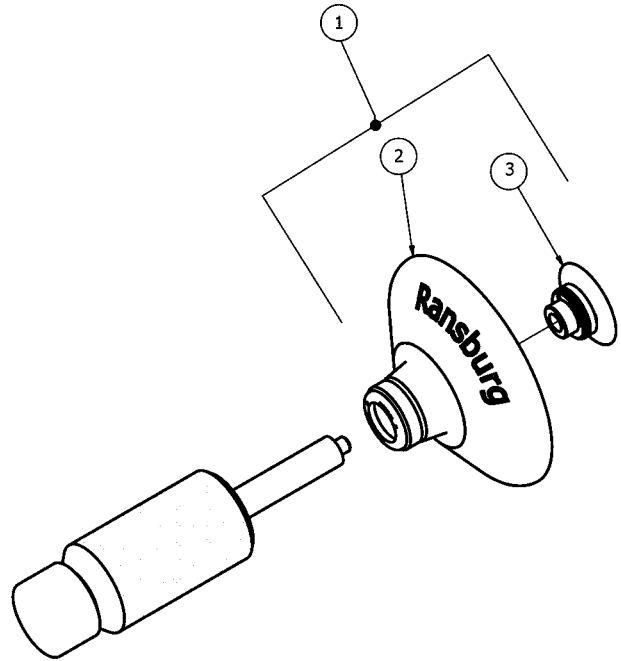

Bell Cup Parts Breakdown

TYPICAL BELL CUP PARTS BREAKDOWN				
Item #	Complete Assembly ①	Description	Cup Only ②	Splash Plate Assembly ③
1	A13114-00	55mm Titanium Serrated (TISF)	A13113-00	A11269-00
2	A13114-01	55mm Titanium Non-Serrated (TIF)	A13113-01	A11269-00
3	A12900-00	65mm Serrated, 65mm (TISF)	A12886-00	A12071-00
4	A12900-01	65mm Non-Serrated, 65mm (TIF)	A12886-01	A12071-00
5	A12900-02	65mm Serrated, 65mm with Long Life Splash Plate (TISF)	A12886-00	A13004-00
6	A12900-03	65mm Non-Serrated, 65mm with Long Life Life Splash Plate (TIF)	A12886-01	A13004-00
7	A12900-04	65mm Serrated, Aluminum with Plastic Splash Plate	A12886-02	A12071-00
8	A12900-05	65mm Non-Serrated, Aluminum with Plastic Splash Plate	A12886-03	A12071-00

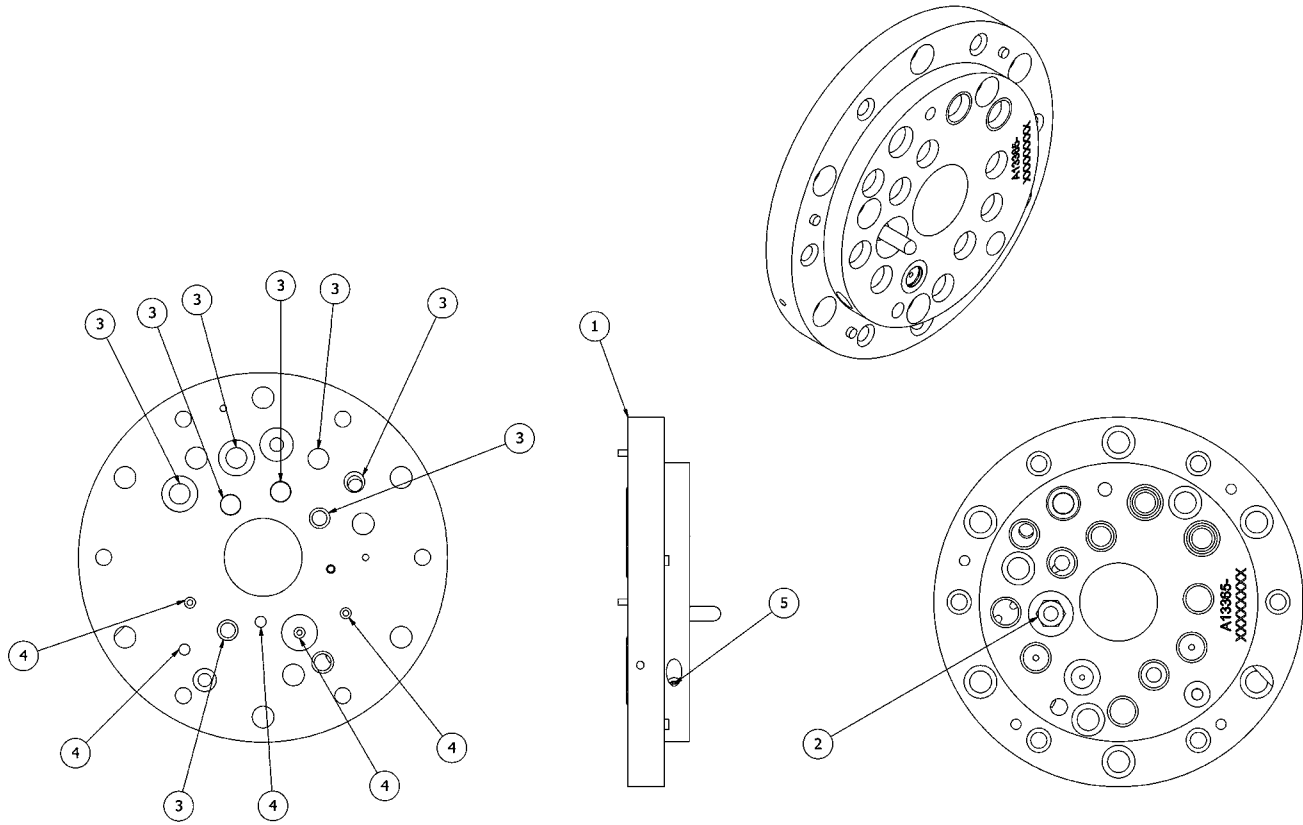

A13453-00 REAR PLATE ASSEMBLY PARTS LIST			
Item	Qty	Part Number	Description
1	1	A13442-00	REAR PLATE ASSEMBLY (INDIRECT)
2	1	A11694-00	BANANA PLUG ASSEMBLY
3	8	79001-40	O-RING, SOLVENT PROOF
4	5	79001-39	O-RING, SOLVENT PROOF
5	1	A13437-00	SET SCREW (M4 NYLON POINT)

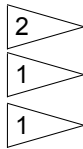

2 Tighten to 5-10 lbs./in/torque (.56 - 1.13 Nm)

1 Apply a thin film of SSL-11 petrolatum jell to all o-rings prior to assembling.

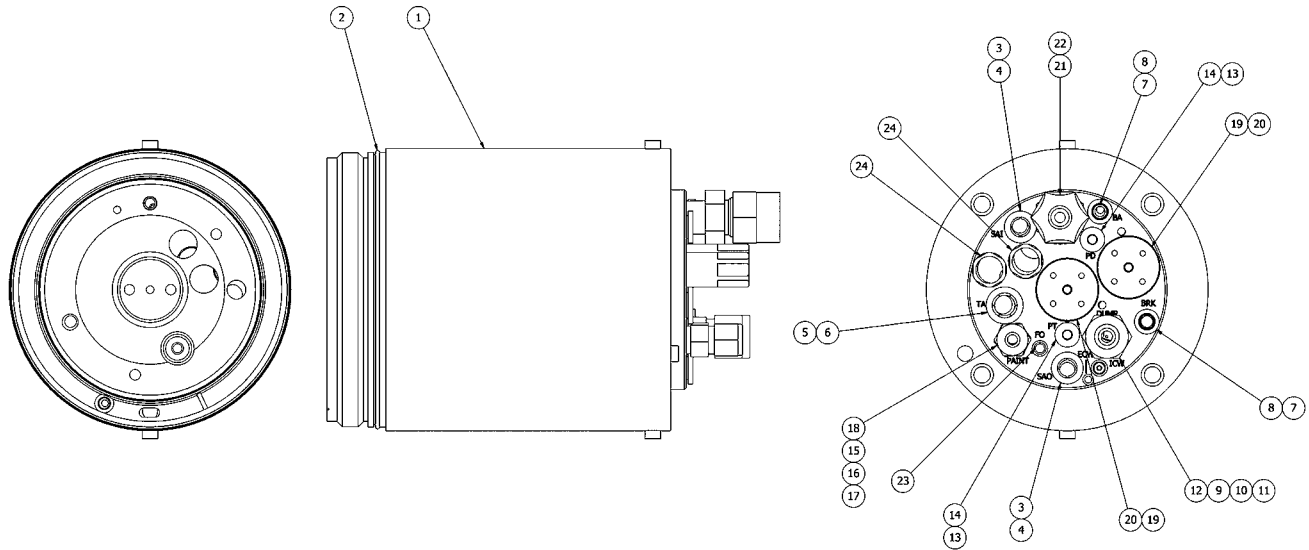

A13451-01 APPLICATOR MOUNTING ASSEMBLY - PARTS LIST			
ITEM #	QTY	PART #	DESCRIPTION
1	1	A13450-01	ATOMIZER MOUNTING BODY ASSEMBLY
4	2	79001-22	O-RING, SOLVENT PROOF
4	2	79001-34	O-RING, SOLVENT PROOF
4	2	77762-04	COLLET, 8MM
4	1	79001-31	O-RING, SOLVENT PROOF
4	1	77762-02	COLLET, 10MM
4	2	79001-32	O-RING, SOLVENT PROOF
8	2	77762-01	COLLET (6MM TUBE)
3	1	78266-00	FITTING, 10MM ODT X AN
10	1	78272-00	FERRULE, REAR 10MM
11	1	78271-00	FERRULE, FRONT 10MM
12	1	78274-00	NUT, MODIFIED 10MM
4	2	79001-30	O-RING, SOLVENT PROOF
14	2	77516-04	COLLET, 4MM
3	1	78265-00	FTG, NY, 6MM, METRIC
16	1	78269-00	FERRULE, FRONT 10MM
17	1	78270-00	FERRULE, REAR 10MM
18	1	78273-00	NUT, MODIFIED 10MM
2	2	77367-00	VALVE SEAT ASSEMBLY
1	2	78949-00	VALVE ASSEMBLY (NON-REPAIRABLE)
21	1	13521-03	FERRULE NUT, NYLON
22	1	18687-00	CONNECTOR BODY
1	1	79001-03	O-RING, SOLVENT PROOF
24	2	A13452-00	EXHAUST TUBE (INDIRECT)

- 4 ▷ APPLY A11545-00 PETROLATUM JEL TO ALL O-RINGS BEFORE INSTALLATION
- 3 ▷ TORQUE TO 15 LBS./IN. AFTER FITTING IS SEATED (1.68 Nm)
- 2 ▷ TORQUE TO 15-20 LBS./IN. (1.68 - 2.24 Nm)
- 1 ▷ TORQUE TO 15-20 LBS./IN. AFTER VALVE IS DOWN (1.68 - 2.24 Nm)

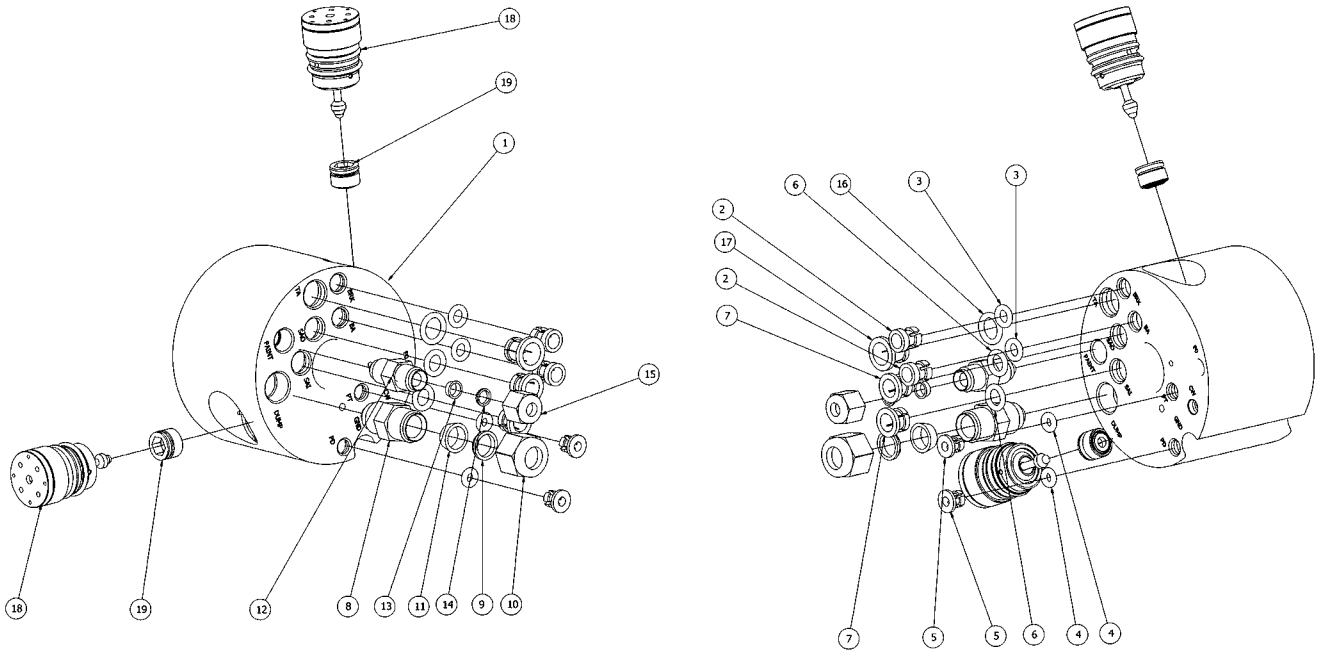

A11692-00 VALVE MANIFOLD ASSEMBLY - PARTS LIST			
ITEM #	QTY	PART #	DESCRIPTION
1	1	A11683-00	SOLVENT/AIR CHOP MANIFOLD
2	2	77762-01	COLLET, 6MM
3	2	79001-32	O-RING, SOLVENT PROOF
4	2	79001-30	O-RING, SOLVENT PROOF
5	2	77516-04	COLLET, 4MM
6	2	79001-34	O-RING, SOLVENT PROOF
7	2	77762-04	COLLET, 8MM
8	1	78266-00	FITTING, 10MM AN
9	1	78272-00	FERRULE, BACK, 10MM
10	1	78274-00	NUT, MODIFIED 10MM OD
11	1	78271-00	FERRULE, FRONT, 10MM
12	1	78265-00	FITTING 6MM AN
13	1	78269-00	FERRULE, FRONT, 6MM
14	1	78270-00	FERRULE, BACK, 6MM
15	1	78273-00	NUT, 6MM OD
16	1	79001-31	O-RING, SOLVENT PROOF
17	1	77762-02	COLLET, 10MM
18	2	78949-00	VALVE ASSEMBLY
19	2	77367-00	VALVE SEAT ASSEMBLY



- 3 ▷ APPLY A11545-00 PETROLATUM JELL ONTO ALL O-RINGS BEFORE INSTALLATION
- 2 ▷ INSTALL VALVE ASSEMBLIES AS SHOWN. APPLY A11545-00 PETROLATUM JELL ONTO O-RINGS. TORQUE TO 15-20 LBS-IN AFTER VALVE IS DOWN. (1.68 - 2.24 Nm)
- 1 ▷ INSTALL VALVE SEAT ASSEMBLIES AS SHOWN TORQUE TO 15-20 LB-IN. (1.68 - 2.24 Nm)

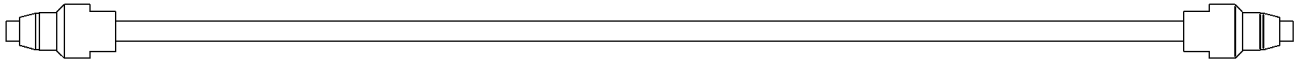

Figure 66: A11351-03/04 Cup Wash Line Assembly

NOTE

- A11351-03 - Install between rear of turbine manifold and valve assembly.
- A11351-04 - Install between valve manifold assembly and shaping air manifold.

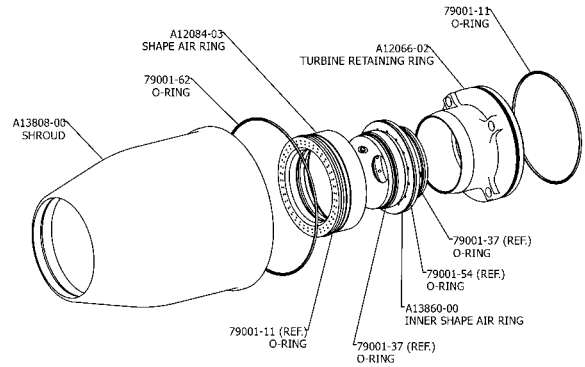

Figure 67B: A13858-02 Shape Air Kit (Dual-Flex Shape Air) All PTFE Parts

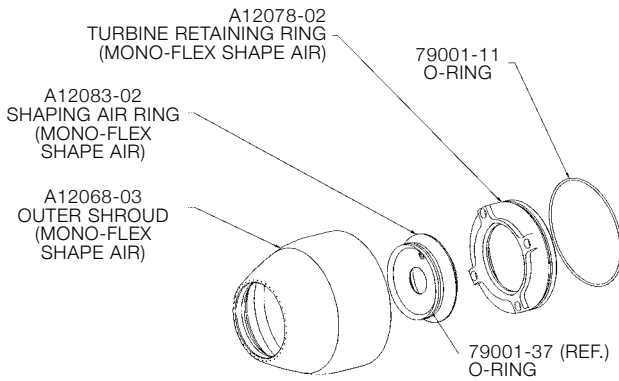

Figure 67: A12874-07 Shaping Air Kit (Mono-Flex Shape Air)

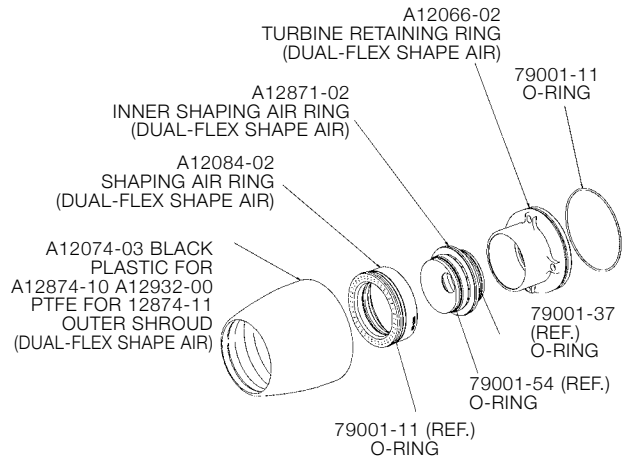

Figure 68a: A12874-10/-11 Shaping Air Kit (Dual-Flex Shape Air)

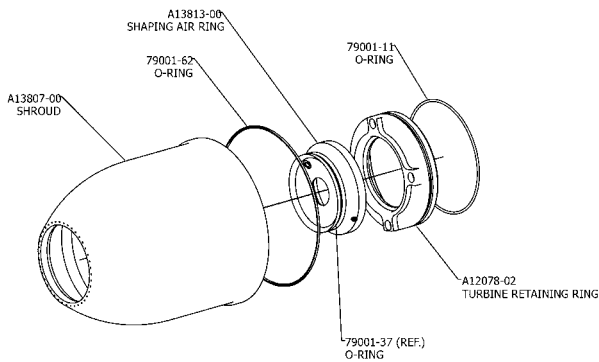

Figure 67A: A13858-01 Shape Air Kit (Mono-Flex Shape Air) All PTFE Parts

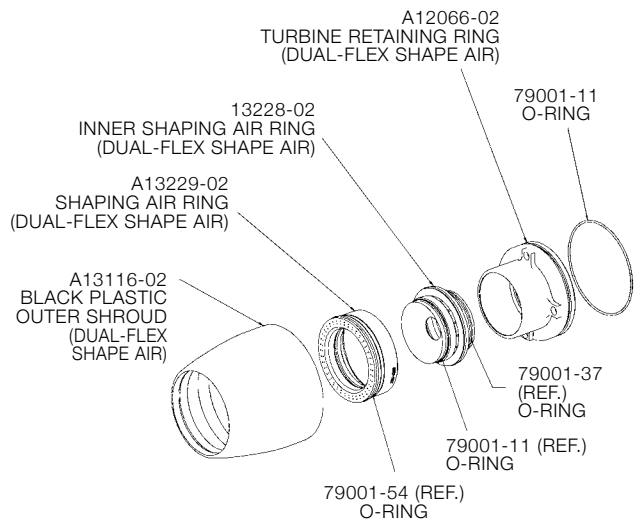

Figure 68b: A12874-13 Shaping Air Kit (Dual-Flex Shape Air for A13114-XX 55mm Bell Cup)

VIEW LOOKING AT FACE
OF ROBOT PLATE

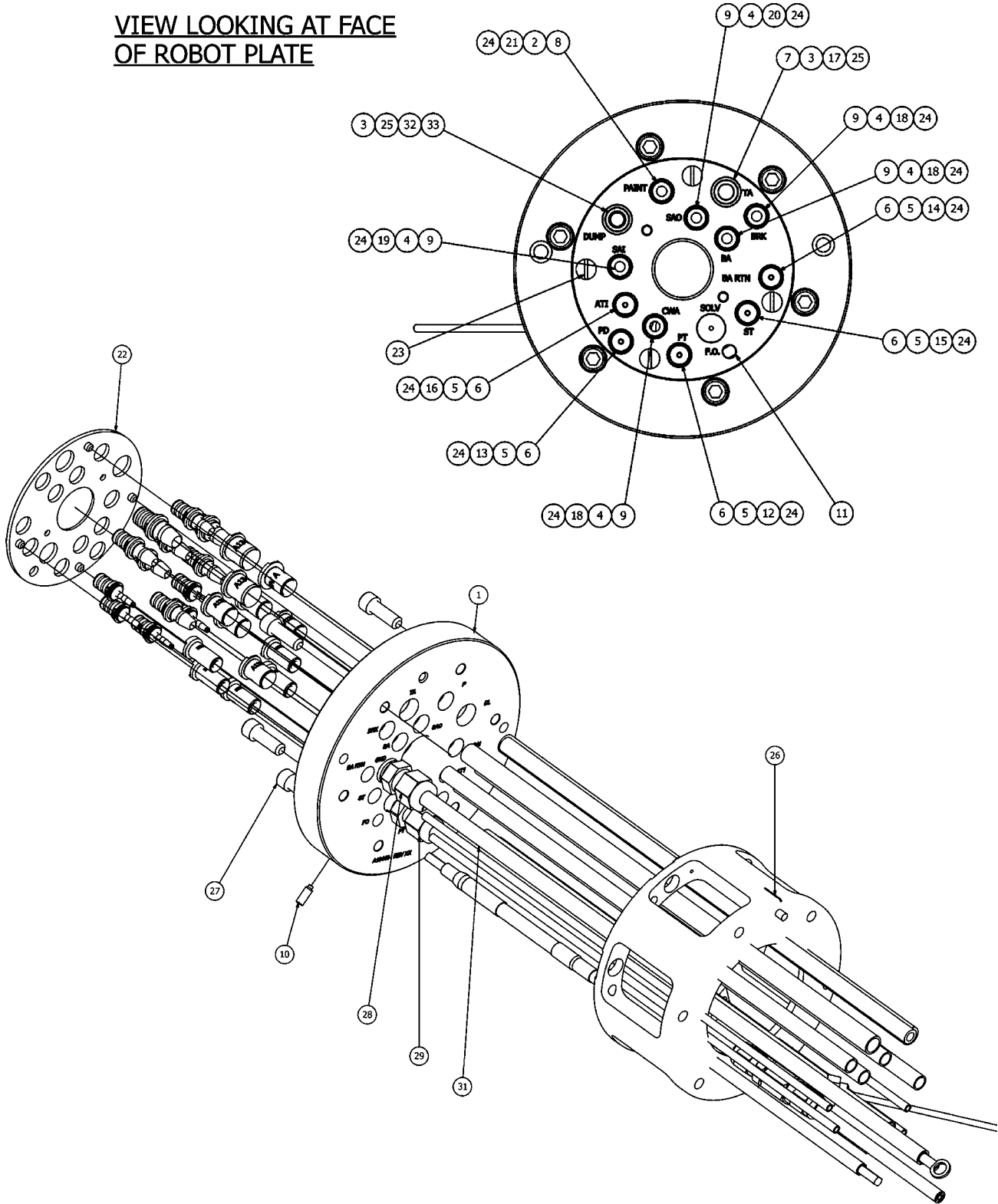

Figure 69a: A13454-XXXXX Tubing Bundle Assembly

A13454-XXXXX TUBING BUNDLE ASSEMBLY - PARTS LIST (Figure 69a)					
Item	Qty	Part #	Description	Where Used	
1	1	A13443-00	ROBOT PLATE (INDIRECT)		
2	1	A13405-00	RECEIVER (8 X 5)	PAINT	
3	2	A13406-00	RECEIVER (10MM)	TA, DUMP	
4	5	A13399-00	RECEIVER (8 X 6)	SAO, SAI, BRK, BA, CWA	
5	5	A13409-00	TUBE RECEIVER (4 X 2.7)	ST, PT, PD, BA, RTN, ATI	
6	5	A13407-00	FITTING (4MM X 2.7MM WITH FLANGE)	PT, PD, ST, ATI, BA, RTN	
7	1	A13408-00	BARB FITTING (10 X 8)	TA	
8	1	A13410-00	BARB FITTING (8 X 5)	PAINT	
9	5	A13400-00	BARB FITTING (8 X 6)	SAO, SAI, BRK, BA, CWA	
9	1	A13437-00	SET SCREW (M4 NYLON POINT)	FIBER OPTIC	
11	1	B	FIBER OPTIC CABLE		
12	"E"	77536-03	TUBING, 4MM O.D. (GREEN)	PT	
13	"F"	77536-06	TUBING, 4MM O.D. (GREY)	PD	
14	"G"	77536-07	TUBING, 4MM O.D. (YELLOW)	BRG, RTN	
15	"H"	77536-04	TUBING, 4MM O.D. (BLUE)	ST	
16	"I"	77536-08	TUBING, 4MM O.D. (ORANGE)	ATI	
17	"J"	A10839-06	TUBE, 10MM OD X 8MM ID (GREEN)	TA	
18	"K"	A10893-10	TUBING (8 X 6) NATURAL	BA, BRK, CWA	
19	"L"	A10893-07	TUBING (8 X 6) BLUE	SAI	
20	"M"	A10893-04	TUBING (8 X 6) GRAY	SAO	
21	"N"	76698-02	TUBING, PFA 450	PAINT	
22	1	A13445-00	RETENTION PLATE (INDIRECT)		
23	4	A13438-00	SCREW, FLAT HEAD SLOTTED, M4 X 16MM, SS	RETENTION PLATE	
24	22	79001-04	O-RING, SOLVENT PROOF	SAO, SAI, BRK, BA, CWA, PT, PD, BA, RTN, PAINT, ST, ATI	
25	4	79001-05	O-RING, SOLVENT PROOF	TA, DUMP	
26	1	C	ROBOT ADAPTER		
27	6	76566-24C	SCREW, STAINLESS 1/4-20 X 3/4 LG. S.H.C.S.	ROBOT PLATE TO ROBOT ADAPTER	
3	28	1	A10890-02	FITTING, 8MM ODT X 1/4 BSP	SOLVENT
29	1	A11283-00	SOLVENT CIRCULATION LINE ASSEMBLY		
30	1	A	HIGH VOLTAGE CABLE ASSEMBLY (NOT SHOWN)		
8	31	1	D	GROUND CABLE ASSEMBLY (RMA-303)	
32	1	A13538-00	BARB FITTING (10 X 7)	DUMP	
33	E	A12211-00	TUBING (10MM X 7MM NYLON)	DUMP	

9 TIGHTEN A13437-00 SET SCREW TO 15-10 LBS./IN. TORQUE (REF. F.O. CABLE) (1.3 - 2.24 Nm)

8 AFTER INSTALLING A11680-XX (REF.) GROUND CABLE ASSEMBLY, TIGHTEN NUT TO 175 LBS./IN. TORQUE. CHECK RESISTIVITY FROM A13443-00 (REF.) ROBOT PLATE TO RING TERMINAL AT END OF CABLE MUST BE 10 OHMS OR LESS.

3 APPLY 7969-10 THREAD SEALER TO THREADS PRIOR TO ASSEMBLING.

A13454-XXXXXXX TUBING BUNDLE ASSEMBLY MODEL IDENTIFICATION

When ordering, use A13454-ABCD and E as indicated by Tables A, B, C, D, and E.
Eight (8) digits must follow the basic part number. For Example:

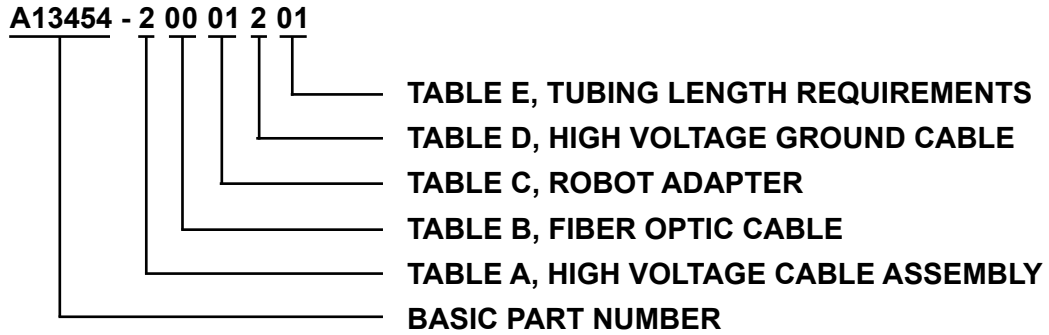

TUBING BUNDLE NOMENCLATURE	
SAO	OUTER SHAPING AIR (OUTER AIR)
SAI	INNER SHAPING AIR (INNER AIR)
BA	BEARING AIR SUPPLY
BRG, RTN	BEARING AIR RETURN
PD	DUMP TRIGGER
DL	DUMP OUT
PT	PAINT TRIGGER
P	PAINT SUPPLY
ST	SOLVENT TRIGGER
SOL	SOLVENT SUPPLY
TA	TURBINE AIR SUPPLY
LV	LOW VOLTAGE CABLE PORT
FO	FIBER OPTIC CABLE PORT
CWA	CUP WASH AIR
ATI	CUP WASH AIR TRIGGER
BRK	BREAK AIR
GND	GROUND CABLE

TABLE A - HIGH VOLTAGE CABLE ASSEMBLY		
Dash #	Description	A
0	NONE	N/A
1	HV CABLE ASSEMBLY, SHIELDED, NON-METALLIC CENTER CONDUCTOR, 15 FT.	A10560-16
2	HV CABLE ASSEMBLY, SHIELDED, NON-METALLIC CENTER CONDUCTOR, 20 FT.	A10560-20
3	HV CABLE ASSEMBLY, SHIELDED, NON-METALLIC CENTER CONDUCTOR, 25 FT.	A10560-25
4	HV CABLE ASSEMBLY, SHIELDED, NON-METALLIC CENTER CONDUCTOR, 50 FT.	A10560-50
5	HV CABLE ASSEMBLY, SHIELDED, NON-METALLIC CENTER CONDUCTOR, 75 FT.	A10560-75
6	HV CABLE ASSEMBLY, SHIELDED, NON-METALLIC CENTER CONDUCTOR, 100 FT.	A10560-100

TABLE B - FIBER OPTIC CABLE		
Dash #	Description	B
00	NONE	N/A
01	3 FOOT FIBER OPTIC CABLE	A12409-01
02	6 FOOT FIBER OPTIC CABLE	A12409-02
03	10 FOOT FIBER OPTIC CABLE	A12409-03
04	15 FOOT FIBER OPTIC CABLE	A12409-04
05	25 FOOT FIBER OPTIC CABLE	A12409-05
06	40 FOOT FIBER OPTIC CABLE	A12409-06
07	50 FOOT FIBER OPTIC CABLE	A12409-07
08	65 FOOT FIBER OPTIC CABLE	A12409-08
09	75 FOOT FIBER OPTIC CABLE	A12409-09
10	100 FOOT FIBER OPTIC CABLE	A12409-10

TABLE C - ROBOT ADAPTER		
Dash #	Description	C
0	NONE	N/A
1	(FANUC P-145/155)	78983-00
2	(ABB 5400, 5002)	79107-00
3	(FANUC P-200/250)	79131-00
4	(KAWASAKI KE610L)	A10847-00
5	(MOTOMAN PX2850)	A10848-00
6	(MOTOMAN PX2900)	A10849-00
7	(B&M LZ2000)	A10851-00
8	(ABB 5400 ENHANCED WRIST)	A12036-00
9	(MOTOMAN EXP 2050)	A13697-00
10	(FANUC P200/250) LONG	A13733-00
11	(KAWASAKI KE610L) LONG	A13734-00
12	(ABB 5400 ENHANCED WRIST) LONG	A13735-00
13	(MOTOMAN EXP 2050) LONG	A13736-00

TABLE D - HIGH VOLTAGE GROUND CABLE		
Dash #	Description	D
0	NONE	N/A
1	CABLE, HIGH VOLTAGE GROUND (10 FT.)	A11680-10
2	CABLE, HIGH VOLTAGE GROUND (25 FT.)	A11680-25
3	CABLE, HIGH VOLTAGE GROUND (50 FT.)	A11680-50
4	CABLE, HIGH VOLTAGE GROUND (75 FT.)	A11680-75
5	CABLE, HIGH VOLTAGE GROUND (100 FT.)	A11680-100

TABLE E - TUBING LENGTH REQUIREMENTS										
Dash #	“E”	“F”	“G”	“H”	“I”	“J”	“K”	“L”	“M”	“N”
00	NONE	NONE	NONE	NONE	NONE	NONE	NONE	NONE	NONE	NONE
01	42 FT.	42 FT.	42 FT.	42 FT.	42 FT.	6 FT.	42 FT. X 3	42 FT.	42 FT.	42 FT.

ATOMIZER RECOMMENDED SPARE PARTS		
Part No.	Description	Qty
A12895-XX *	Air Turbine Assembly	0-1
A11351-03	Assembly, Cup Wash Tubing	1
A13535-00	Fluid Tube Assembly	0-1
75911-00	Fiber Optic Transmitter Assembly	1
75921-01	Fiber Optic Cable Assembly	0-1
77367-00	Valve Seat Assembly	3-5
A11252-01	Tubing, FEP (Cup Wash)	50 ft.(20 meters)
78278-00	Nut, Fiber Optic Transmitter	0-1
79001-03	O-ring, Solvent Proof	5-10
79001-06	O-ring, Solvent Proof	5-10
79001-07	O-ring, Solvent Proof	3-5
79001-11	O-ring, Solvent Proof	1-2
79001-22	O-ring, Solvent Proof	1-2
79001-30	O-ring, Solvent Proof	2
79001-31	O-ring, Solvent Proof	2-4
79001-32	O-ring, Solvent Proof	2-4
79001-34	O-ring, Solvent Proof	2-4
79001-39	O-ring, Solvent Proof	6-12
79001-40	O-ring, Solvent Proof	10-15
79001-41	O-ring, Solvent Proof	1
79001-42	O-ring, Solvent Proof	1
79001-44	O-ring, Solvent Proof	1
79001-45	O-ring, Solvent Proof	1-2
79001-46	O-ring, Solvent Proof	1
79001-47	O-ring, Solvent Proof	1
LSOR0005-12	O-ring, Encapsulated	1
A13437-00	Set Screw (F.O. and LV cables)	3
A11276-00	Fitting, Solvent (Cup Wash)	1-2
A11305-00	Lower Ferrule (Black- Cup Wash)	3-4
A11534-01	O-ring Kit (Turbine- Exterior)	1
A12253-00	Set Screw (Shape Air Manifolds)	1-2
A12822-00	Cup Wash Fitting	1-2
78949-00	Fluid Valve Assembly	3-5
A11351-03	Assembly, Cup Wash Tubing	1
A11682-01	Screw, Captured	6
A11690-01	Screw, Captured	8
A11338-00	Screw, Socket Head Cap, G10 Fiberglass	4-6

* Customer must verify correct part number when re-ordering.

ATOMIZER RECOMMENDED SPARE PARTS (Cont.)		
Part No.	Description	Qty
A11337-00	Screw, Socket Head Cap, Stainless	4-6
13521-03	Ferrule Nut	1
78266-00	Fitting, 10mm AN	0-1
78272-00	Ferrule, Back, 10mm	1-2
78274-00	Nut, Modified, 10mm OD	0-1
78271-00	Ferrule, Front, 10mm	1-2
78265-00	Fitting, 6mm AN	0-1
78269-00	Ferrule, Front, 6mm	1-2
78270-00	Ferrule, Back, 6mm	1-2
78273-00	Nut, 6mm OD	0-1
77762-01	Collet, 6mm	2-4
77516-04	Collet, 4mm	2-4
77762-04	Collet, 8mm	2-4
77762-02	Collet, 10mm	1-2
78441-00	Ferrule, nut	1-2
A12079-00	High Voltage ring	0-1
A11318-00	Locknut, High Voltage Tube	0-1
A11691-00	Bent Tube	0-1
Select Option Below- Fluid Tip Size		
A11240-01	.7mm (.028")	0-1
A11240-02	.9mm (.035")	0-1
A11240-03	1.1mm (.043")	0-1
A11240-04	1.2mm (.047")	0-1
A11240-05	1.6mm (.062")	0-1
A11240-06	1.0mm (.039")	0-1
Select Option Below- Mounting Ring		
A13455-01	Mounting Ring Plastic W/Skirt Extension (White)	0-1
A11201-00	Mounting Ring Stainless Steel	0-1
Select Option Below- Electrode		
A11343-02	Electrode Assembly, 220 Megohm	1-2
A11343-03	Electrode Assembly, 140 Megohm	1-2
A11342-00	Electrode Body Assembly	1-2
Select Option Below- Bell Cup Assembly W/Splash Plate		
A13114-00	55mm Serrated, Titanium (TISF)	1
A13114-01	55mm Non-Serrated, Titanium (TIF)	1
A12900-00	65mm Titanium Serrated (TISF)	1
A12900-01	65mm Titanium Non-Serrated (TIF)	1

ATOMIZER RECOMMENDED SPARE PARTS (Cont.)		
Part No.	Description	Qty
Select Option Below- Bell Cup Assembly W/Splash Plate (Cont.)		
A12900-02	65mm Titanium Serrated W/Long Life Splash Plate (TISF)	1
A12900-03	65mm Titanium Non-Serrated W/Long Life Splash Plate	1
A12900-04	65mm Aluminum Serrated W/Plastic Splash Plate	1
A12900-05	65mm Aluminum Non-Serrated W/Long Life Splash Plate	1
Select Option Below- Bell Cup Only		
A12886-00	65mm Titanium Serrated (TISF)	1
A12886-01	65mm Titanium Non-Serrated (TIF)	1
A12886-02	65mm Aluminum Serrated (ALS)	1
A12886-03	65mm Aluminum Non-Serrated (ALF)	1
A13113-00	55mm Titanium Serrated (TISF)	1
A13113-01	55mm Titanium Non-Serrated (TIF)	1
Select Option Below- Splash Plate Assembly		
A11269-00	For 55mm Bell Cups (White Color)	1
A12071-00	For 65mm Bell Cups (Black Color)	1
A13004-00	For 65mm Bell Cups (Long Life- Titanium top)	1
Select Option Below- Bell Cup Assembly W/Splash Plate		
A13114-00	55mm Serrated, Titanium (TISF)	1
A13114-01	55mm Non-Serrated, Titanium (TIF)	1
A12900-00	65mm Titanium Serrated (TISF)	1
A12900-01	65mm Titanium Non-Serrated (TIF)	1
A12900-02	65mm Titanium Serrated W/Long Life Splash Plate (TISF)	1
A12900-03	65mm Titanium Non-Serrated W/Long Life Splash Plate	1
A12900-04	65mm Aluminum Serrated W/Plastic Splash Plate	1
A12900-05	65mm Aluminum Non-Serrated W/Long Life Splash Plate	1
Select Option Below- Bell Cup Only		
A12886-00	65mm Titanium Serrated (TISF)	1
A12886-01	65mm Titanium Non-Serrated (TIF)	1
A12886-02	65mm Aluminum Serrated (ALS)	1
A12886-03	65mm Aluminum Non-Serrated (ALF)	1
A13113-00	55mm Titanium Serrated (TISF)	1
A13113-01	55mm Titanium Non-Serrated (TIF)	1
Select Option Below- Splash Plate Assembly		
A11269-00	For 55mm Bell Cups (White Color)	1
A12071-00	For 65mm Bell Cups (Black Color)	1
A13004-00	For 65mm Bell Cups (Long Life- Titanium top)	1

BELL CUP SPARE PARTS LIST		
Part No.	Description	Qty
Select Option Below- A13436 Tubing Bundle Assembly		
A13455-00	Retention Plate	1
A13438-00	Screw (For Retention Plate)	3-5
A13437-00	Set Screw (For Low Voltage Cable and Fiber Optic)	1-2
79001-04	O-ring, Solvent Proof	10-15
79001-05	O-ring, Solvent Proof	2-4
A13410-00	Barb Fitting (8x5)	1-2
A13405-00	Receiver (8x5)	1-2
A13400-00	Barb Fitting (8x6)	1-2
A13399-00	Receiver (8x6)	1-2
A13408-00	Barb Fitting (10x8)	1-2
A13406-00	Receiver (10x8) (10x7)	1-2
A13538-00	Barb Fitting (10x7)	1-2
A13407-00	Barb Fitting (4mm)	1-2
A13409-00	Receiver (4mm)	1-2
76566-24C	Screw, Stainless Steel 1/4-20 x 3/4 SHCS	2-4
A11283-00	Solvent Circulation Line Assembly	1-2
Select Option Below- High Voltage Cable		
A10560-16	H.V. Cable Assembly, Shielded, Non-Metallic Center Conductor, 15 Ft.	1
A10560-20	H.V. Cable Assembly, Shielded, Non-Metallic Center Conductor, 20 Ft.	1
A10560-25	H.V. Cable Assembly, Shielded, Non-Metallic Center Conductor, 25 Ft.	1
A10560-50	H.V. Cable Assembly, Shielded, Non-Metallic Center Conductor, 50 Ft.	1
A10560-75	H.V. Cable Assembly, Shielded, Non-Metallic Center Conductor, 75 Ft.	1
A1-560-100	H.V. Cable Assembly, Shielded, Non-Metallic Center Conductor, 100 Ft.	1
Select Option Below- Fiber Optic Cable		
A12409-01	3 Ft. (0.9 Meters)	1
A12409-02	6 Ft. (1.8 Meters)	1
A12409-03	10 Ft. (3 Meters)	1
A12409-04	15 Ft. (4.6 Meters)	1
A12409-05	25 Ft. (7.6 Meters)	1
A12409-06	40 Ft. (12.2 meters)	1
A12409-07	50 Ft. (15.2 Meters)	1
A12409-08	65 Ft. (18.3 Meters)	1
A12409-09	75 Ft. (22.9 Meters)	1
A12409-10	100 Ft. (30.5 Meters)	1

TUBE BUNDLE SPARE PARTS LIST		
Part No.	Description	Qty
Select Option Below- Tubing		
77536-01	Tubing 4mm Nylon (Black)	---
77536-03	Tubing 4mm Nylon (Green)	---
77536-04	Tubing 4mm Nylon (Blue)	---
77536-05	Tubing 4mm Nylon (Natural)	---
77536-06	Tubing 4mm Nylon (Grey)	---
77536-07	Tubing 4mm Nylon (Yellow)	---
76698-02	Tubing, PFA	---
A10893-04	Tubing 8 x 6 Nylon (Gray)	---
A10893-07	Tubing 8 x 6 Nylon (Blue)	---
A10893-10	Tubing 8 x 6 Nylon (Natural)	---
A12211-00	Tubing 10 x 7 Nylon (Natural)	---
77566-08	Tubing 4mm Nylon (Orange)	---
A10839-06	Tubing 10 x 8 Nylon (Green)	---
Select Option Below- High Voltage Ground Cable		
A11680-10	Cable, High Voltage Ground (10 Ft.)	1
A11680-25	Cable, High Voltage Ground (25 Ft.)	1
A11680-50	Cable, High Voltage Ground (50 Ft.)	1
A11680-75	Cable, High Voltage Ground (75 Ft.)	1
A11680-100	Cable, High Voltage Ground (100 Ft.)	1
Select Option Below- Shaping Air Kit A12874-07 (65mm Mono Flex)		
A12068-03	Outer Shroud	0-1
A12083-02	Shaping Air Ring	0-1
A12078-02	Turbine Retaining ring	0-1
79001-11	O-ring	1
79001-37	O-ring	1
A12253-00	Set Screw	1-2
Select Option Below- Shaping Air Kit A12874-10 (65mm Dual Flex)		
A12074-03	Outer Shroud	0-1
A12084-02	Shaping Air Ring	0-1
A12871-02	Inner Shaping Air ring	0-1
A12066-02	Turbine Retaining Ring	0-1
79001-11	O-ring	1
79001-37	O-ring	1-2
79001-54	O-ring	1
A12253-00	Set Screw	1-2

TUBE BUNDLE SPARE PARTS LIST (Cont.)		
Part No.	Description	Qty
Select Option Below- Shaping Air Kit A12874-11 (65mm Dual Flex)		
A12932-00	Outer Shroud	0-1
A12084-02	Shaping Air Ring	0-1
A12871-02	Inner Shaping Air ring	0-1
A12066-02	Turbine Retaining Ring	0-1
79001-11	O-ring	1
79001-37	O-ring	1-2
79001-54	O-ring	1
A12253-00	Set Screw	1-2
Select Option Below- Shaping Air Kit A12874-13 (55mm Dual Flex)		
A13116-02	Outer Shroud	0-1
A13229-02	Shaping Air Ring	0-1
A12066-02	Turbine Retaining Ring	0-1
A13228-02	Inner Shaping Air Ring	0-1
79001-11	O-ring	1
79001-37	O-ring	1-2
79001-54	O-ring	1
A12253-00	Set Screw	1-2
Select Option Below- Shaping Air Kit A13858-02 (65mm Dual Flex) All PTFE Parts		
A13808-00	Outer Shroud	0-1
A12084-03	Shaping Air Ring	0-1
A12066-02	Turbine Retaining Ring	0-1
A13860-00	Inner Shaping Air Ring	0-1
79001-11	O-ring	1
79001-37	O-ring	1
A12253-00	Set Screw	1-2
79001-62	O-ring (Rear shroud)	1
Select Option Below- Shaping Air Kit A13858-01 (65mm Mono Flex) All PTFE Parts		
A13807-00	Outer Shroud	0-1
A13813-00	Shaping Air Ring	0-1
A12078-02	Turbine Retaining Ring	0-1
79001-11	O-ring	1
79001-37	O-ring	1
A12253-00	Set Screw	1-2
79001-62	O-ring (Rear shroud)	1

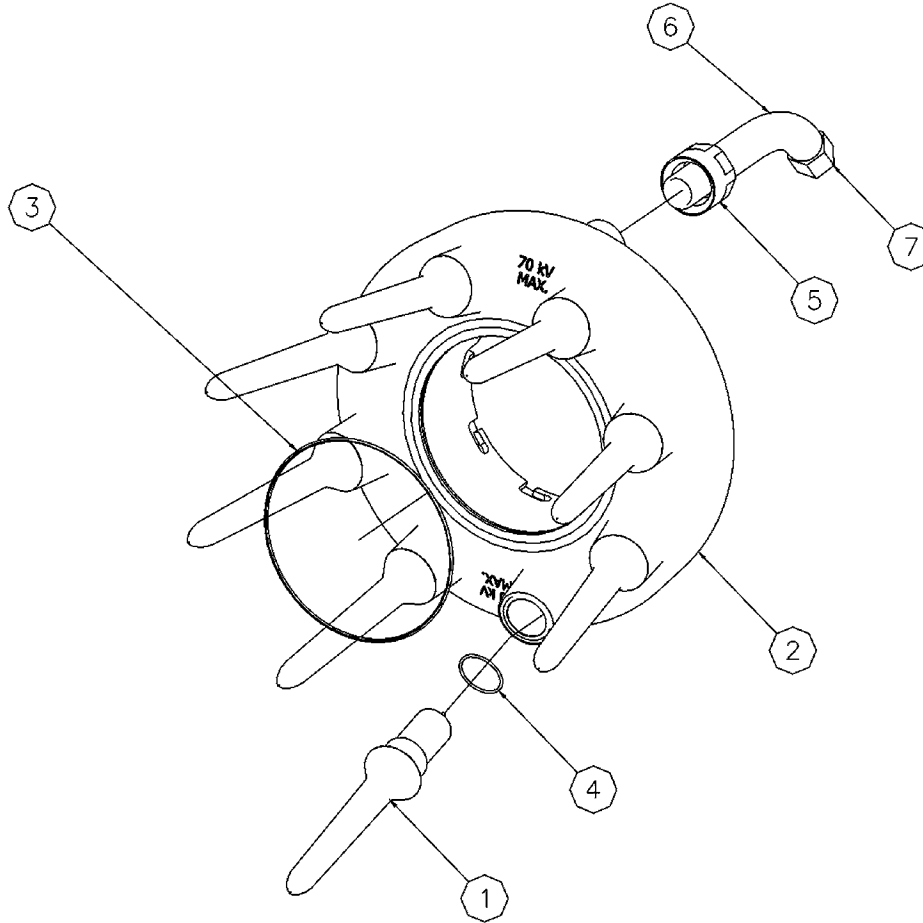

A11536-XX HIGH VOLTAGE RING KIT - PARTS LIST			
Item #	Qty	Part #	Description
1	8	"A"	ELECTRODE ASSEMBLY
2	1	A12079-00	HIGH VOLTAGE RING
3	1	LSOR0005-14	O-RING, ENCAPSULATED
4	8	79001-45	O-RING, SOLVENT PROOF
5	1	A11318-00	LOCKNUT, HIGH VOLTAGE TUBE
6	1	A11317-00	BENT TUBE
7	1	78441-00	FERRULE NUT, 3/8" OD

ELECTRODE ASSEMBLY - PARTS LIST		
Part #	A	Description
A11536-00	A11343-02	AT SEA LEVEL
A11536-01	A11343-03	AT 5000 FT. ABOVE SEA LEVEL OR HIGHER

SERVICE KITS	
Part #	Description
RPM-32	Pro-Filter Replacement Element
RPM-33	Bearing Air Filter Element
74947-06	Cable Assembly (Low Voltage Cable), 30 Ft.
74947-04	Cable Assembly (Low Voltage Cable), 75 Ft.
74947-05	Cable Assembly (Low Voltage Cable), 100 Ft.
74793-01	Cascade RansPak 1000, Right Angle Connection
74793-02	Cascade RansPak 1000, Straight Connection
A11570-01	Reducing Straight Connector, Push to Connect, 6mm OD Tube to 4mm OD Tube
A11570-02	Reducing Straight Connector, Push to Connect, 8mm OD Tube to 4mm OD Tube
A11570-03	Reducing Straight Connector, Push to Connect, 8mm OD Tube to 6mm OD Tube
A11570-04	Reducing Straight Connector, Push to Connect, 10mm OD Tube to 4mm OD Tube
A11570-05	Reducing Straight Connector, Push to Connect, 10mm OD to 6mm OD Tube
A11570-06	Reducing Straight Connector, Push to Connect, 10mm OD to 8mm OD Tube
A11570-07	Reducing Straight Connector, Push to Connect, 12mm OD to 8mm OD Tube
A11570-08	Reducing Straight Connector, Push to Connect, 12mm OD to 10mm OD Tube
77762-03	Collet, 12mm
A12138-01	Nut, 8mm
A13294	Fitting, 8mm ODT X AN
A12138-03	Ferrule, Rear 8mm
A12138-02	Ferrule, Front 8mm

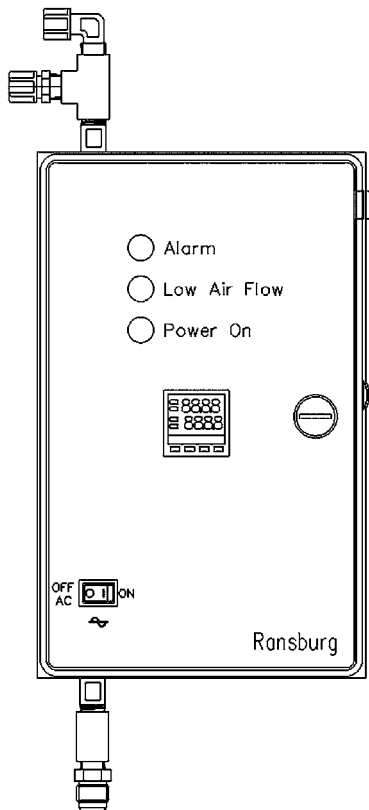

A11065-05 Air Heater

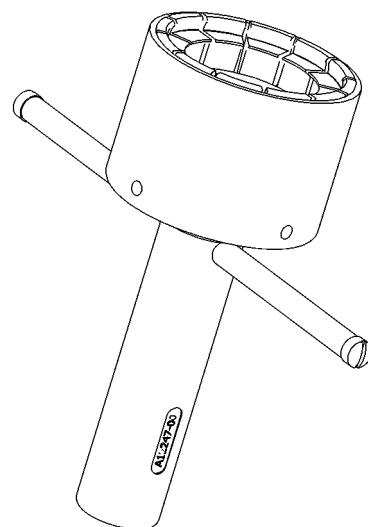

A12247-00 Bell Cup Tool

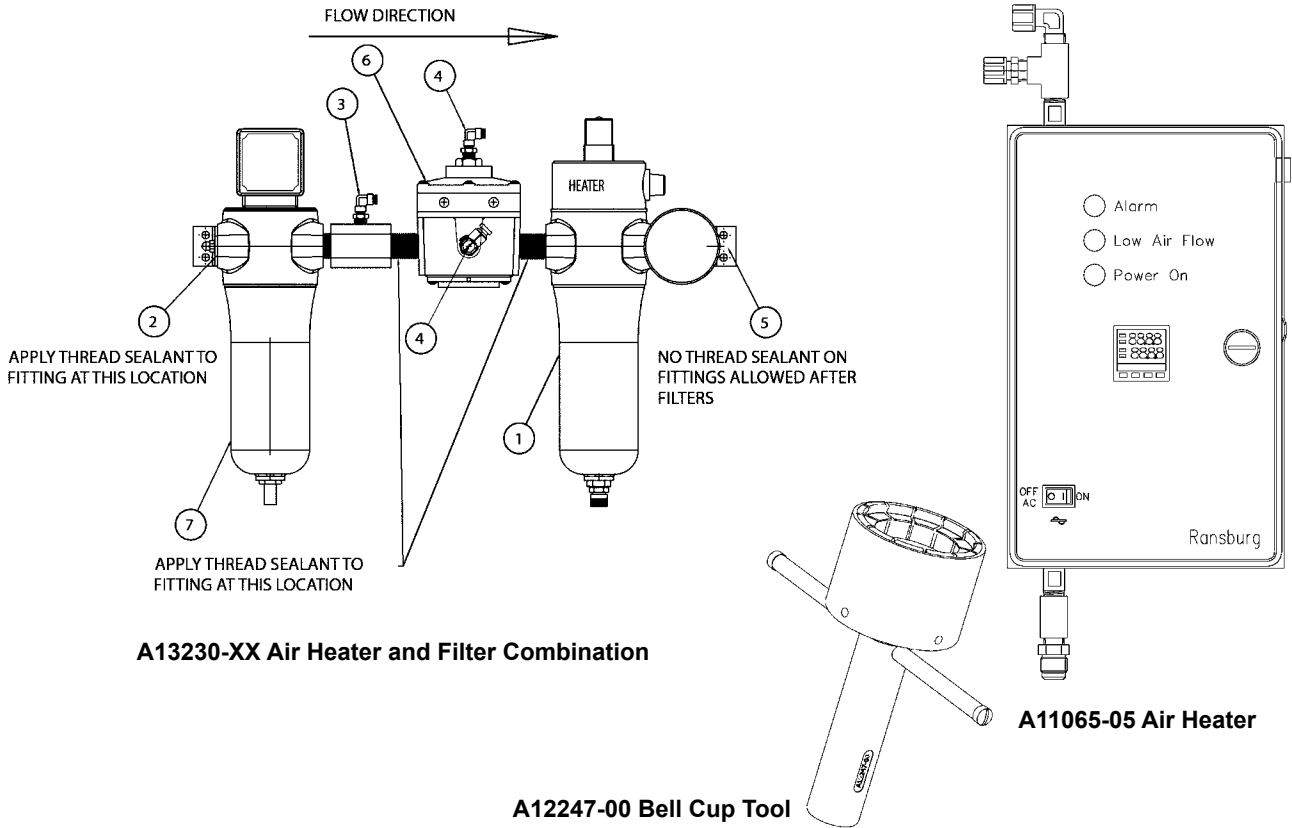

A13230-XX Air Heater and Filter Combination

A11065-05 Air Heater

A12247-00 Bell Cup Tool

FILTER & HEATER ASSEMBLY A13230-XX					
Dash No.	Description	"A"	"B"	"C"	"E"
A13230-01	115 V.@ 13A METRIC FITTINGS	A13434-01	A13426-00	A13429-00	A13726-00
A13230-02	230 V.@ 6.5A METRIC FITTINGS	A13434-02	A13426-00	A13429-00	A13726-00
A13230-03	115 V.@ 13A FRACTIONAL FITTINGS	A13434-01	SSP-6439	A13428-00	A13727-00
A13230-04	230 V.@6.5A FRACTIONAL FITTINGS	A13434-02	SSP-6439	A13428-00	A13727-00

A13230-XX AIR HEATER AND FILTER COMBINATION			
Item	Part #	Description	Qty.
1	"A"	AIR BLOCK, NIPPLES & AIR HEATER	1
2	A13427-00	INLET FITTING, 3/8 NPS(M) X 1/2 NPT(M)	1
3	"B"	BEARING AIR FEED, SWIVEL ELBOW 1/4 O.D.TUBE X 1/4 NPT(M)	1
		BEARING AIR FEED, 6mm O.D. TUBE X 1/4 NPT(M) STRAIGHT ADAPTER	
4	79253-02	AIR FITTING, SWIVEL ELBOW 5/32 O.D. TUBE X 1/4 NPT(M)	2
5	"C"	OUTLET FITTING, 1/2 O.D. TUBE X 1/2 NPT(M) STAINLESS STEEL	1
		OUTLET FITTING, 12mm O.D. TUBE X 1/2 NPT(M) STAINLESS STEEL	
6	"E"	VOLUME BOOSTER	1
7	A13433-00	AIR FILTER & NIPPLE INCLUDED	1
8	SI-13-07	A13230-XX SERVICE LITERATURE (PROVIDED BY OTHER)	REF.

ALL UNITS: REPLACEMENT PARTS: (SERVICE NOTE)
 HEATING ELEMENT USE: A13432-01 FOR A13230-01 AND A13230-03 (115V UNITS)
 A13432-02 FOR A13230-02 AND A13230-04 (230V UNITS)
 AIR FILTER ELEMENT USE A13232-00
 THERMOMETER USE A13431-00

WARRANTY POLICIES

LIMITED WARRANTY

Ransburg will replace or repair without charge any part and/or equipment that falls within the specified time (see below) because of faulty workmanship or material, provided that the equipment has been used and maintained in accordance with Ransburg's written safety and operating instructions, and has been used under normal operating conditions. Normal wear items are excluded.

THE USE OF OTHER THAN RANSBURG APPROVED PARTS, VOID ALL WARRANTIES.

SPARE PARTS:

One hundred and eighty (180) days from date of purchase, except for rebuilt parts (any part number ending in "R") for which the warranty period is ninety (90) days.

EQUIPMENT:

When purchased as a complete unit, (i.e., guns, power supplies, control units, etc.), is one (1) year from date of purchase. **WRAPPING THE APPLICATOR IN PLASTIC, SHRINK-WRAP, ETC., WILL VOID THIS WARRANTY.**

RANSBURG'S ONLY OBLIGATION UNDER THIS WARRANTY IS TO REPLACE PARTS THAT HAVE FAILED BECAUSE OF FAULTY WORKMANSHIP OR MATERIALS. THERE ARE NO IMPLIED WARRANTIES NOR WARRANTIES OF EITHER MERCHANTABILITY OR FITNESS FOR A PARTICULAR PURPOSE. RANSBURG ASSUMES NO LIABILITY FOR INJURY, DAMAGE TO PROPERTY OR FOR CONSEQUENTIAL DAMAGES FOR LOSS OF GOODWILL OR PRODUCTION OR INCOME, WHICH RESULT FROM USE OR MISUSE OF THE EQUIPMENT BY PURCHASER OR OTHERS.

EXCLUSIONS:

If, in Ransburg's opinion the warranty item in question, or other items damaged by this part was improperly installed, operated or maintained, Ransburg will assume no responsibility for repair or replacement of the item or items. The purchaser, therefore will assume all responsibility for any cost of repair or replacement and service related costs if applicable.

Specific Air Turbine Warranty

The air turbine only is warranted for 15,000 operating hours, or 3 years from date of first installation, whichever comes first. If, after inspection by Ransburg, defect is

confirmed, we will repair or replace the air turbine, free of charge, during the warranty period. The repaired air turbine (or replacement air turbine) will continue to be warranted for the remainder of the initial warranty period (from installation date). The warranty period for the air turbine does not begin again when a repair is completed under warranty. Air turbines repaired by Ransburg after the warranty period will be warranted for 90 days from the date of shipment from the repair center.

The Warranty does not cover:

1. An RMA 570 that has become inoperative because of:
 - a. Misuse - Particularly the flooding of the rotor area due to turning on the fluid before the turbine is up to speed
 - b. Negligence.
 - c. Accidents - Collisions with external objects, fires, or similar occurrences.
 - d. Improper maintenance procedures.
 - e. Attempted customer repair of an air turbine during warranty.
 - f. Failure to insure clean air to air bearing and turbine.
 - g. Operating turbine without bearing air.
 - h. Operating turbine with less than minimum specified air bearing pressure. (80 psi 5.51 Bar)
 - i. Operating with imbalanced loads (heavy paint buildup on atomizer bell or shaft, or damaged atomizer bell cup).
 - j. Acts of God, flood, earthquake, or similar occurrences.
 - k. RMA-570's being operated by control systems not designed by Ransburg, or when others have
2. Labor or incidental costs occasioned by removal, replacement or repair of rotary atomizer or air turbine (other than by Ransburg) unless we have given specific written or telegraphic authorization for repair by someone other than Ransburg.
3. Rotary atomizers determined by Ransburg not to have been installed and maintained in accordance with Ransburg service manual instructions.
4. Cost of repair/replacement and return transportation from Ransburg of merchandise determined not to be defective.

MANUAL CHANGE SUMMARY

Supersede Service Manual **LN-9275-13.0** with the following changes:

1. Change to 100 krpm in “Features” — **Page 6.**
2. Adjust “Turbine Speed” in Specifications — **Page 8.**
3. Update Fluid Flow Rate in Specifications — **Page 8.**
4. Update Table name to add “Short Adapter” — **Page 15.**
5. Add new page with new drawing — **Page 16.**
6. Change part numbers in column “E” — **Page 23.**
7. Change part numbers for Dash # 6 and 7 — **Page 23.**
8. Update copy for “Electrical and Fiber Optic Connections” — **Page 24.**
9. Add “Sample Configurations” in Shape Air — **Pages 31-32.**
10. Remove “Sample Configurations” copy and NOTE — **Page 33.**
11. Change flow rate to 1000 cc/min. in WARNING 3 — **Page 37.**
12. Remove windows from drawing — **Page 16.**
13. Change rpms — **Page 27.**
14. Change 800 cc/min. to 1000 — **Page 30.**
15. Change table name — **Pages 32-33.**
16. Change flow rate to 1000 cc/min. in both WARNINGS — **Page 40.**
17. Remove “Weep Port Locations” drawings and copy — **Page 59.**
18. Update part number for item 2 TABLE F — **Page 74.**
19. Change part numbers for items 1, 20-25 in parts list — **Page 78.**
20. Change part number for item 1 — **Page 82.**
21. Update flag call out 9 — **Page 86.**
22. Correct part number in item 2 TABLE B — **Page 88.**
23. Add 5 items to bottom of TABLE C — **Page 88.**
24. Correct column letter in TABLE E — **Page 89.**
25. Change part numbers for captured screws in Spare Parts — **Page 90.**
26. Change row head to “Splash Plate Assembly” — **Page 93.**
27. Change part numbers in column “E” — **Page 98.**
28. Change part numbers for Dash # 6 and 7 — **Page 98.**
29. Add text to “Warranty” — **Page 99.**

Supersede Service Manual **LN-9275-13.1** with the following changes:

1. Change to 100 krpm in “Features” — **Page 6.**
2. Adjust “Turbine Speed” in Specifications — **Page 8.**
3. Update Fluid Flow Rate in Specifications — **Page 8.**
4. Update Table name to add “Short Adapter” — **Page 15.**
5. Add new page with new drawing — **Page 16.**
6. Change part numbers in column “E” — **Page 23.**
7. Change part numbers for Dash # 6 and 7 — **Page 23.**
8. Update copy for “Electrical and Fiber Optic Connections” — **Page 24.**
9. Add “Sample Configurations” in Shape Air — **Pages 31-32.**
10. Remove “Sample Configurations” copy and NOTE — **Page 33.**
11. Change flow rate to 1000 cc/min. in WARNING 3 — **Page 37.**
12. Remove windows from drawing — **Page 16.**
13. Change rpms — **Page 27.**
14. Change 800 cc/min. to 1000 — **Page 30.**
15. Change table name — **Pages 32-33.**
16. Change flow rate to 1000 cc/min. in both WARNINGS — **Page 40.**

Manufacturing

1910 North Wayne Street
Angola, Indiana 46703-9100
Telephone: 260-665-8800
Fax: 260-665-8516

Technical Service — Assistance

320 Philips Ave.
Toledo, Ohio 43612-1493
Telephone (toll free): 800-233-3366
Fax: 419-470-2233

Technical Support Representative will direct you to the appropriate telephone number for ordering Spare Parts.

Form No. LN-9275-13.2
Litho in U.S.A.
04/15

© 2015 Carlisle Fluid Technologies, dba Finishing Brands
All rights reserved. Models and specifications subject to change without notice.

