

SERVICE MANUAL

**LN-9409-01.4**

Replaced LN-9409-01.3

April-2014

## RansFlow & RansPulse Fluid Metering Systems



**MODELS: A12410 (RansFlow)  
A13334 (RansPulse)**

**IMPORTANT:** Before using this equipment, carefully read SAFETY PRECAUTIONS, starting on page 5, and all instructions in this manual. Keep this Service Manual for future reference.

**NOTES**

# CONTENTS

Section 1: SAFETY	5-9
Safety Precautions	
Hazards / Safeguards	
<hr/>	
Section 2: INTRODUCTION	10-22
RansFlow / RansPulse	
Specifications	
Features	
RansFlow / RansPulse Selection Guide	
<hr/>	
Section 3: INSTALLATION	23-41
System Guidelines	
Electrical Connections	
Air Connections	
Fluid Connections	
Discrete Gun Inputs & Outputs	
Discrete System Inputs & Outputs	
<hr/>	
Section 4: PROGRAMMING	42-82
Main Screen	
Configure	
System Parameters	
Gun Parameters	
Channel Parameters	
Advanced Channel Parameters	
Job Parameters	
Alarms	
Reports	
Information	
Color Change Sequence	
Tools	
Force I/O	
View Inputs	
Emulator	

Section 5: OPERATION	83-85
Emulator / Remote Operator Panel Screen	
Start Spraying	
Finished Spraying	

---

Section 6: TROUBLESHOOTING	86-91
Power Supply	
Flow Too High / Flow Too Low	
Out of Tolerance	
Reverse Flow	
No Master Flow	

---

Section 7: APPENDIX	92-97
Icon Definitions	
Remote Operator Panel (ROP) Error Codes	
High Voltage Interlock Valve	
Warranty Policies	

---

Section 8: Drawings/Schematics	100
Table of Contents	

# Section 1: SAFETY

Before operating, maintaining or servicing any Ransburg electrostatic coating system, read and understand all of the technical and safety literature for your Ransburg products. This manual contains information that is important for you to know and understand.

This information relates to USER SAFETY and PREVENTING EQUIPMENT PROBLEMS. To help you recognize this information, we use the following symbols:



**CAUTION** - states information that tells how to prevent damage to equipment or how to avoid a situation that might cause minor injury.



**WARNING** - states information to alert you to a situation that might cause serious injury if instructions are not followed.

While this manual lists standard specifications and service procedures, some minor deviations may be found between the literature and your equipment. Differences in local codes and plant requirements, material delivery requirements, etc., make such variations inevitable. Compare this manual with your system installation drawings and appropriate Ransburg equipment manuals to reconcile such differences.

Careful study and continued use of this manual will provide a better understanding of the equipment and process, resulting in more efficient operation, longer trouble-free service and faster, easier troubleshooting. If you do not have the manuals and safety literature for your Ransburg system, contact your local Ransburg representative or Ransburg.



## WARNING

- The user **MUST** read and be familiar with the Safety Section in this manual and the Ransburg safety literature therein identified.
- This manual **MUST** be read and thoroughly understood by **ALL** personnel who operate, clean or maintain this equipment! Special care should be taken to ensure that the WARNINGS and safety requirements for operating and servicing the equipment are followed. The user should be aware of and adhere to **ALL** local building and fire codes and ordinances as well as NFPA 33 SAFETY STANDARD, 2011 EDITION, prior to installing, operating, and/or servicing this equipment.
- The hazards shown on the following pages may occur during normal use of this equipment. Please read the hazard chart beginning on page 6.

AREA	HAZARD	SAFEGUARDS
------	--------	------------

**Spray Area**



**Fire Hazard**

Improper or inadequate operation and maintenance procedures will cause a fire hazard.

Protection against inadvertent arcing that is capable of causing fire or explosion is lost if any safety interlocks are disabled during operation. Frequent power supply shutdown indicates a problem in the system requiring correction.

**Follow These Guidelines**

Fire extinguishing equipment must be present in the spray area and test periodically.

Spray areas must be kept clean to prevent the accumulation of combustible residues.

Smoking must never be allowed in the spray area.

The high voltage supplied to the atomizer must be turned off prior to cleaning, flushing or maintenance.

When using solvents for cleaning:

- Those used for equipment flushing should have flash points equal to or higher than those of the coating material.
- Those used for general cleaning must have flash points above 100F (37.80C).



Spray booth ventilation must be kept at the rates required by NFPA 33, 2011 Edition, OSHA and local codes. Ventilation must be maintained during cleaning operations using flammable or combustible solvents.



Electrostatic arcing must be prevented.

Non-factory replacement parts or unauthorized equipment modifications may cause fire or injury.

If used, a key switch bypass is intended for use only during setup operations. Production should never be done with safety interlocks disabled.

Never use equipment for use in waterborne installations to spray solvent based materials.

AREA	HAZARD	SAFEGUARDS
<p><b>Spray Area</b></p> 	<p><b>Explosion</b></p> <p>Improper or inadequate operation and maintenance procedures may cause an explosion.</p> <p>Protection against inadvertent arcing that is capable of causing fire or explosion is lost if any safety interlocks are disabled during operation. Frequent power supply shut-down indicates a problem in the system requiring correction.</p>	<p><b>Follow These Guidelines</b></p> <p>Electrostatic arcing <b>MUST</b> be prevented.</p> <p>All electrical equipment must be located outside Class I or II, Division 1 or 2 hazardous areas, in accordance with NFPA 33, 2011 Edition.</p> <p>Test only in areas free of flammable or combustible materials.</p> <p>The current overload sensitivity (if equipped) <b>MUST</b> be set as described in corresponding section of the equipment manual. Protection against inadvertent arcing that is capable of causing fire or explosion is lost if the current overload sensitivity is not properly set. Frequent power shutdown indicates a problem with the system which requires correction.</p> <p>Always turn the control panel off prior to flushing, cleaning, or working on spray system equipment.</p> <p>Ensure that the control panel is interlocked with the ventilation system and conveyor in accordance with NFPA 33, 2011 Edition.</p> <p>Have fire extinguishing equipment readily available and tested periodically.</p>
<p><b>Spray Area</b></p> 	<p><b>Explosion - Incompatible Materials</b></p> <p>Halogenated hydrocarbon solvents for example: methylene chloride and 1,1,1,-Trichloroethane are not chemically compatible with the aluminum that might be used in many system components. The chemical reaction caused by these solvents reacting with aluminum can become violent and lead to an equipment explosion.</p>	<p><b>Follow These Guidelines</b></p> <p>Aluminum is widely used in other spray application equipment - such as material pumps, regulators, triggering valves, etc. Halogenated hydrocarbon solvents must never be used with aluminum equipment during spraying, flushing, or cleaning. Read the label or data sheet for the material you intend to spray. If in doubt as to whether or not a coating or cleaning material is compatible, contact your coating supplier. Any other type of solvent may be used with aluminum equipment.</p>

AREA	HAZARD	SAFEGUARDS
<p><b>Spray Area / High Voltage Equipment</b></p> 	<p><b>Electrical Discharge</b></p> <p>There is a high voltage device that can induce an electrical charge on ungrounded objects which is capable of igniting coating materials.</p> <p>Inadequate grounding will cause a spark hazard. A spark can ignite many coating materials and cause a fire or explosion.</p>	<p><b>Follow These Guidelines</b></p> <p>Parts being sprayed must be supported on conveyors or hangers and be grounded. The resistance between the part and ground must not exceed 1 mega ohm.</p> <p>All electrically conductive objects in the spray area, with the exception of those objects required by the process to be at high voltage, must be grounded.</p> <p>Any person working in the spray area must be grounded.</p> <p>Unless specifically approved for use in hazardous locations, the power supply and other electrical control equipment must NOT be used in Class I, Division 1 or 2 locations.</p>
<p><b>Electrical Equipment</b></p> 	<p><b>Electrical Discharge</b></p> <p>High voltage equipment is utilized. Arcing in areas of flammable or combustible materials may occur. Personnel are exposed to high voltage during operation and maintenance.</p> <p>Protection against inadvertent arcing that may cause a fire or explosion is lost if safety circuits are disabled during operation.</p> <p>Frequent power supply shutdown indicates a problem in the system which requires correction.</p> <p>An electrical arc can ignite coating materials and cause a fire or explosion.</p>	<p><b>Follow These Guidelines</b></p> <p>All electrical equipment must be located outside Class I or II, Division 1 or 2 hazardous areas. Refer to NFPA 33, 2011 Edition.</p> <p>Turn the power supply OFF before working on the equipment.</p> <p>Test only in areas free of flammable or combustible material.</p> <p>Testing may require high voltage to be on, but only as instructed.</p> <p>Production should never be done with the safety circuits disabled.</p> <p>Before turning the high voltage on, make sure no objects are within the sparking distance.</p>



AREA	HAZARD	SAFEGUARDS
<p><b>Toxic Substances</b></p> 	<p><b>Mechanical Hazard</b></p> <p>Certain material may be harmful if inhaled, or if there is contact with the skin.</p>	<p><b>Follow These Guidelines</b></p> <p>Follow the requirements of the Material Safety Data Sheet supplied by the coating manufacturer.</p> <p>Adequate exhaust must be provided to keep the air free of accumulations of toxic materials.</p> <p>Use a mask or respirator whenever there is a chance of inhaling sprayed materials. The mask must be compatible with the material being sprayed and its concentration. Equipment must be as prescribed by an industrial hygienist or safety expert, and be NIOSH approved.</p>
<p><b>Robot Work Area</b></p>	<p><b>Mechanical Hazard</b></p> <p>Improper use or maintenance can lead to hazardous conditions, particularly from unexpected robot manipulator movement.</p>	<p><b>Follow These Guidelines</b></p> <p>Applicator adjustments or maintenance should be done after the robot is taken out of service. Do not adjust or repair the applicator if the robot is operating or standing ready to start.</p> <p>Refer to robot operating instructions for the procedures to take a robot out of service.</p> <p>Follow all OSHA Lockout / Tagout procedures when performing any maintenance.</p>
<p><b>All Areas</b></p>	<p><b>Improper / Inadequate Training</b></p> <p>Improper operation or maintenance may create a hazard.</p> <p>Personnel must be properly trained in the use of this equipment.</p>	<p><b>Follow These Guidelines</b></p> <p>Personnel must be given training in accordance with the requirements of NFPA 33, 2011 Edition.</p> <p>Instructions and safety precautions must understood prior to using this equipment.</p> <p>Comply with appropriate codes governing ventilation, fire protection, operation maintenance, and housekeeping. OSHA references are sections 1910.94 and 1910.107. Also refer to NFPA 33, 2011 Edition and your insurance company requirements.</p>

## Section 2: INTRODUCTION

The RansFlow precisely meters and mixes multi-component materials. The RansPulse controls ratio but not flow rate. These electronic metering systems provide accuracy and repeatability for consistent finish quality.

The RansFlow and RansPulse Systems are composed of the following basic elements...

- Main Control Panel
- Fluid Panel
- Remote Operator Panel (optional)
- Pneumatic Interface Panel (optional on RansFlow, not available on RansPulse)

The Main Control Panel can control up to 3 channels (materials), the fluid panels are available in 1, 2, or 3 channels, and the Pneumatic Interface Panels are available in single or 2-channel models. (Pneumatic Interface Panels are not required on the RansPulse System.) The RansFlow System can be configured for one or two guns, whereas the RansPulse software only allows single-gun configurations.



Main Control Panel



Remote Operator Panel

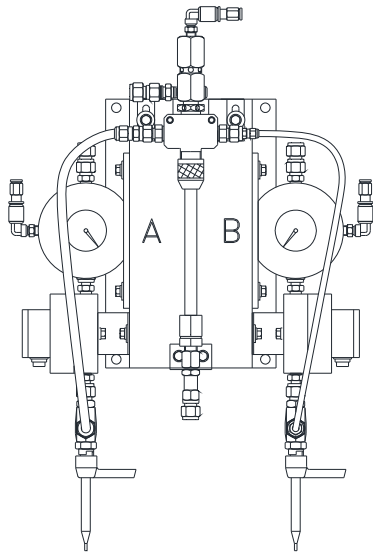

**Note:** For 3-Channel systems, 2 fluid panels will be required.

RansFlow Fluid Panel

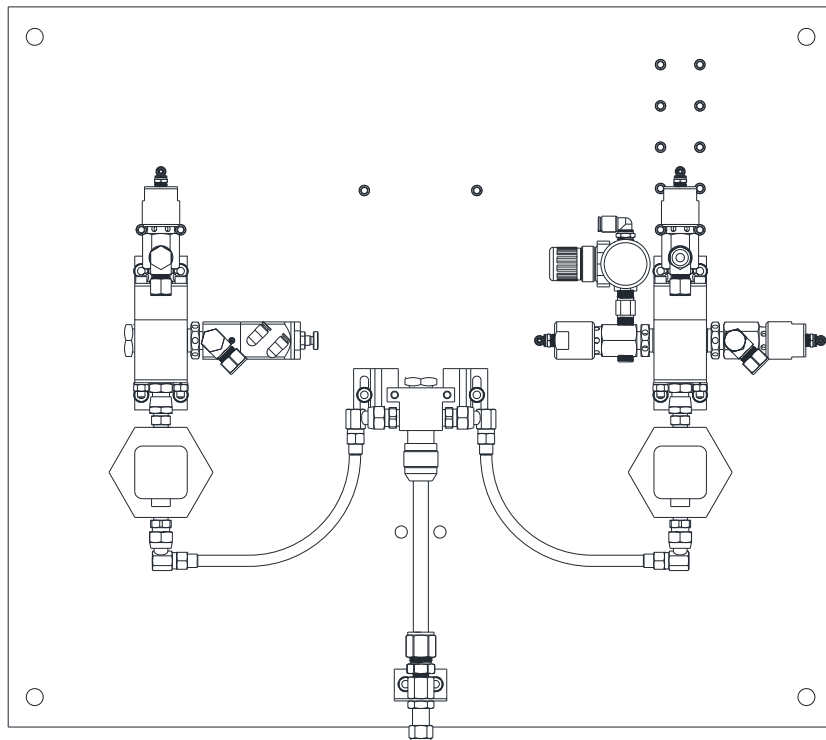

RansPulse Fluid Panel

The RansFlow is a dynamic fluid metering system using flowmeters and flow control valves (regulators) to provide true analog closed-loop flow control.

Operational Block Diagram:

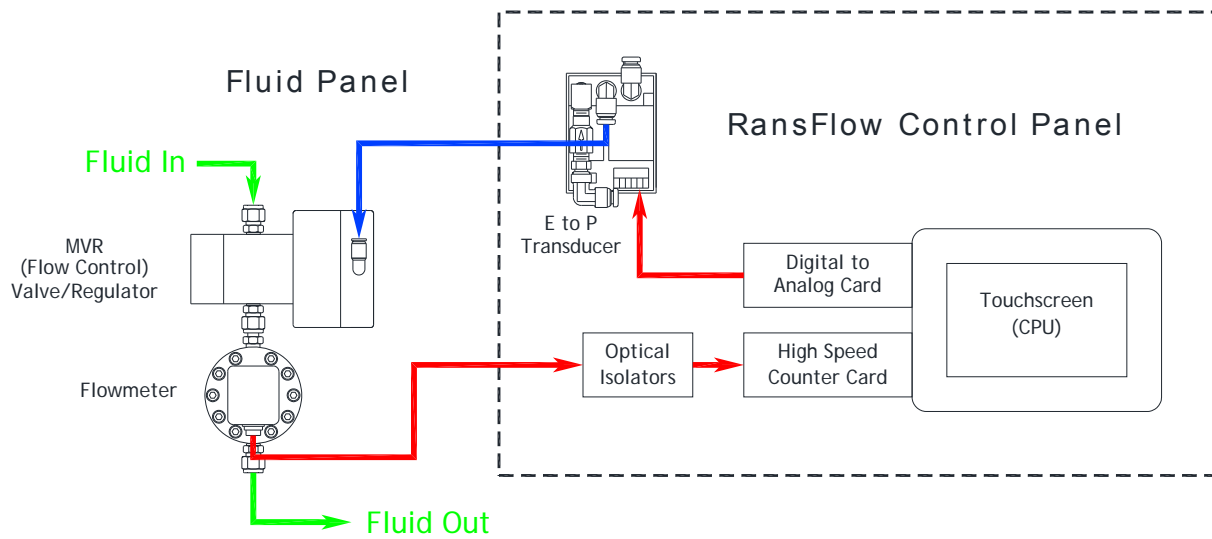

The RansPulse uses the same basic electronics as the RansFlow, however, it controls ratio only by injecting the proper amount of slave material (or materials) in small 'slugs' into the flowing stream of the master-channel material to provide accurate ratio control. The diagram below shows how the ratio is controlled on the slave channel or channels. The master channel material flows unrestricted unless a fault occurs.

Operational Block Diagram:

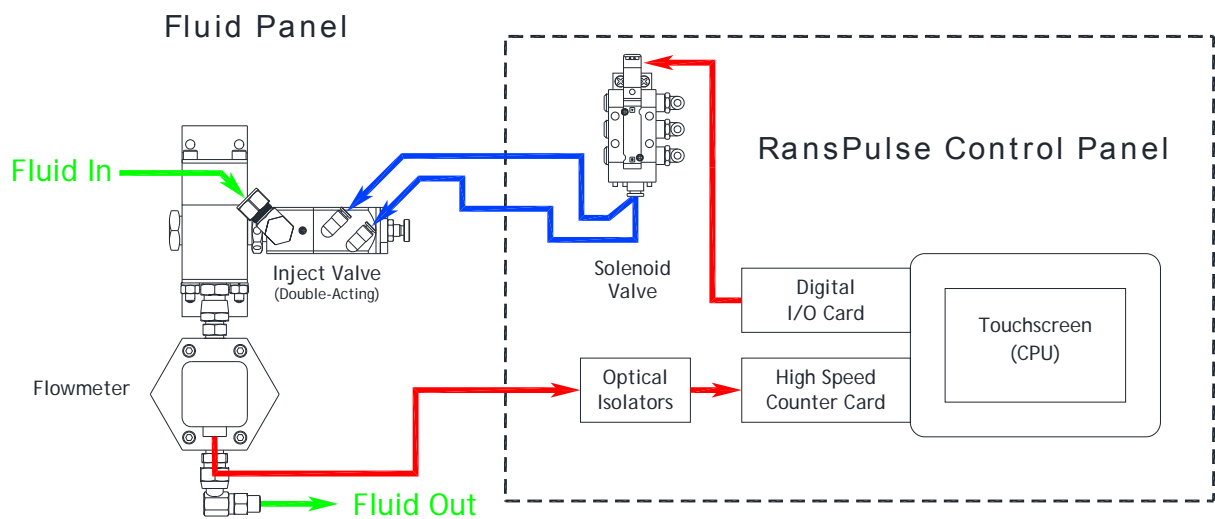

The RansFlow can control up to 3 CHANNELS configured as 1 or 2 GUNS:

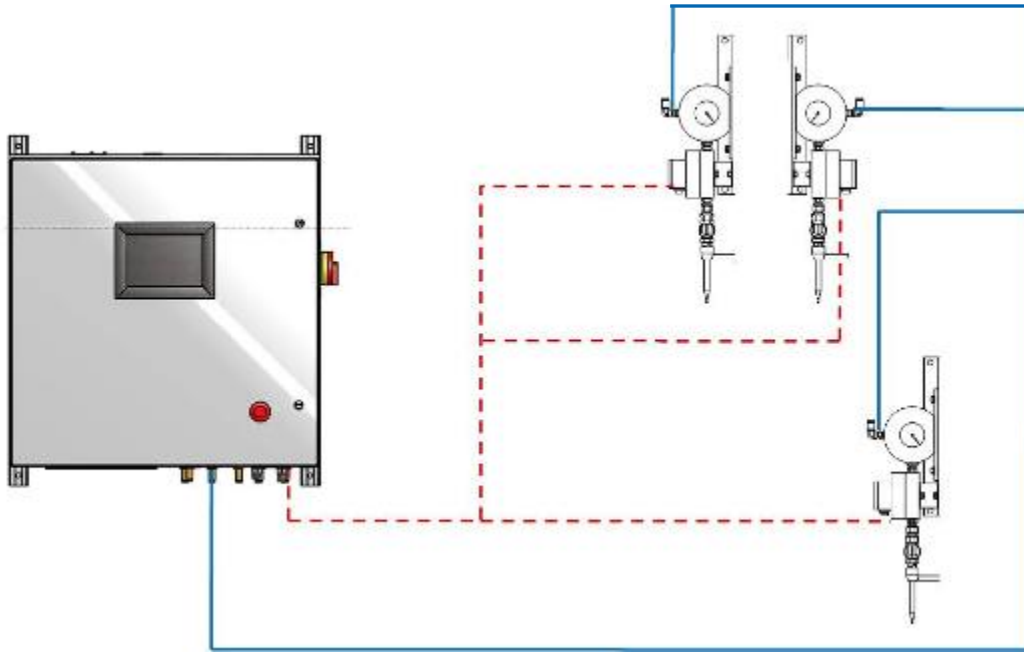

RansFlow will maintain the fluid delivery and ratio at each individual applicator to a tolerance as close as  $\pm 2\%$ . A flow - meter is located in the fluid stream prior to component mixing upstream from each applicator. This flowmeter generates pulses as material flows through it and sends them back to the flow controller. The flow controller converts the pulses to ml/min using a calibration value defined at setup. This actual flow rate will be compared to the operator adjustable set point and ratio. The flow controller will then make an adjustment to the MVR fluid regulators located prior to the flowmeter. This process of measuring, comparing, and, adjusting is repeated 50 times per second, maintaining the required flow rate and ratio for each material. After each component leaves the flowmeters, they come together in a spiral mix tube assembly prior to delivery to the applicator.

Automatic mode utilizes inputs from a robot controller or PLC to set flow rates and ratios and activate triggers, flushes and fills. Manual mode and Inject mode (RansPulse) rely on the operator to control the flow rate of the mixed material. A remote operator panel (depending on the version) is mounted inside or outside the spray booth to allow control of the system by the manual sprayer and to inform the operator of the system's operating conditions. This panel allows the operator to flush, fill, run and reset faults to the unit from inside the booth and it also indicates the condition of the unit: Running, Flushing, Flushed, Loading, Loaded, or Faulted.

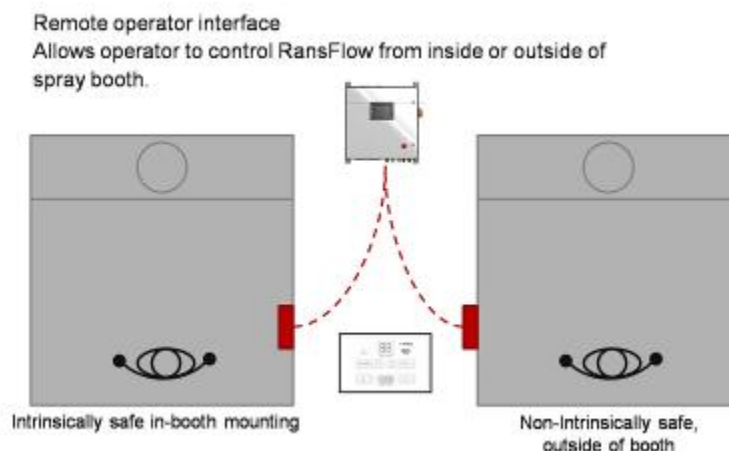

MANUAL MODE examples:

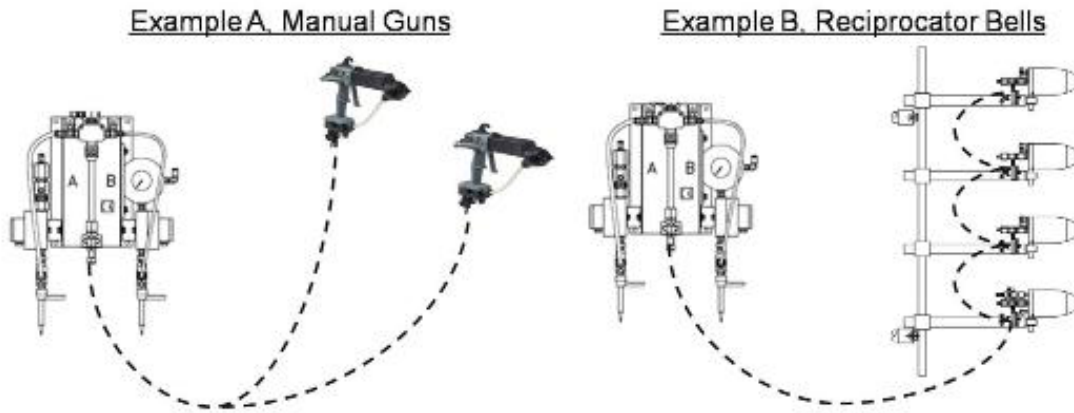

In “Manual Mode”, the flow rate of the resin is controlled by the demand of the operator(s) or equipment and the RansFlow supplies the catalyst to maintain the desired ratio set-point. (In the case of RansPulse, the above fluid panels are replaced with the RansPulse fluid panel shown on page 11.)

AUTOMATIC MODE example:

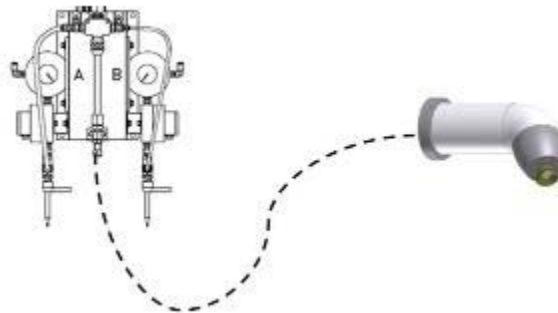

In “Automatic Mode”, a single applicator is supplied and the RansFlow controls the ratio and flow rate to the applicator. The robot can communicate directly with the RansFlow to control the fluid rate with an analog signal or each job can have a preprogrammed fixed flow rate. (The RansPulse is not capable of closed-loop flow control.)

## Main Control Enclosure

The Main Control Enclosure is the heart of the system. It houses the following items:

### RansFlow

- User-interface computer (with touchscreen/LCD)
- PC-104 Interface cards (3)
- Optically isolated interface boards
- 20 Solenoid valves
- E to P transducers (1 to 6)
- DC Power supplies (2)
- Air Flow Switches (2)
- Power and I/O terminal strips

### RansPulse

- User-interface computer (with touchscreen/LCD)
- PC-104 Interface cards (2)
- Optically isolated interface boards
- 5-20 Solenoid valves
- DC Power supplies (2)
- Air Flow Switches (2)
- Power and I/O Terminal Strips

## Main Control Enclosure (continued)

- Pressure Switches (for gun flush box interfacing)
- Optional zener barriers for intrinsically safe flowmeters
- Optional fiberoptic interface modules (for fiberoptic flowmeters)

The user-interface P.C. is equipped with a non-volatile flash-disk that contains a Windows CE operating system and the RansFlow or RansPulse user-interface software. The computer has a USB port for updating its software, for backing up parameter data, and retrieving totalization data.

The three PC-104 I/O cards plug onto the back of the user-interface PC and control all I/O functions, including interfacing with external control devices such as remote PLC's. (RansPulse only has 2 interface boards.)

Ribbon cables connect the PC-104 cards to optically isolated interface boards buffering all I/O to prevent harmful voltages, etc. from damaging the user-interface P.C.

There are two DC power supplies housed in the main control enclosure. One is 24 VDC for all discrete I/O signals. The second supply provides +5 VDC for the optical isolator boards and the user-interface P.C.

On the top of the main control Enclosure are three connectors for I/O. One is for a second gun (37-pins), the second for all system I/O (50-pins), and the third is for the Remote Operator Panel (9-pins).

The E to P pressure transducers convert a 0 to 10 VDC signal from the analog outputs to a proportional 0 to 100 psi air signal. This signal is used to pilot the MVR or DR-1 flow control valves (not required on RansPulse).

The Zener barriers make the flowmeter sensors and Remote Operator Panel intrinsically safe for use inside the spray area.

The air flow switches are used to sense when a handgun is triggered (to prevent flow if a master channel flowmeter sticks).

The pressure switches are used to interface to the optional gun flush boxes to prevent flushing and loading of handguns when they are not in the flush box.

## Fluid Panel (RansFlow)

The Fluid Panels contain all of the 'wetted' components for the RansFlow. These include:

- MVR flow control valves
- Flowmeters
- Mixer Block
- Spiral Mix Tube
- Check Valves
- Calibration Valves
- Optional fluid pressure regulators

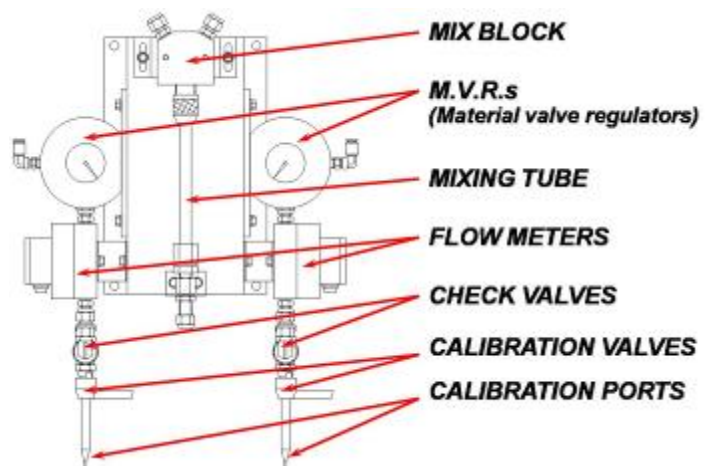





The flowmeters and MVR valves are available in various sizes for various materials and flow rates. Users should consult our technical support group to determine which are required for their specific application.

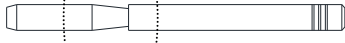

The MVR Valves act as both flow control valves and on-off valves depending on the application. With manual mode guns, the master channel MVR opens 100% during operation and the slave channel or channels are controlled to maintain the proper ratio only. With guns configured in automatic mode, all MVR valves act as flow control valves. There are 3 different needle sizes available for the MVR valves (02 for low flow, 03 for medium flow, and 04 for high flow).

Fluid Panel Components - MVR Valve

- Three “needle” sizes available
  - Size #2: Low Flow, 15 - 350 ml/min
  - Size #3: Moderate Flow, 250 - 2600 ml/min
  - Size #4: High Flow, 1000 - 3500 ml/min

	#2	
	#3	
	#4	

**Weeping MVR Needles**                      **Weepless MVR Needles**

	
--	---

**Note:**

MVR Valves are not required on the RansPulse Units.

The flowmeters act as the feedback mechanism to the software so that it knows the current flow rate of the material. The RansFlow is capable of interfacing with any type of positive displacement flowmeter that is capable of outputting a square wave whose frequency is proportional to the flow rate. It is highly recommended (although not absolutely necessary) that these flowmeters have quadrature outputs so that reverse flow can be detected.

The calibration valves are 3-way ball valves used to direct the flow of material away from the mix block to the calibration tubes. This is used to calibrate the flowmeters.

The check valves prevent backflow of material from one source to another. (Typically, the catalyst is run at a higher pressure than the resin to allow it to ‘inject’ itself into the resin flow stream and can, therefore, back up into the resin supply if an MVR valve is stuck open for any reason.)

The Mix-Block is a four-port manifold that brings the fluid from the outlet of the resin MVR together with the outlet of the catalyst MVR. Attached to the top of the Mix-Block is a port for an optional solvent flush valve for quick flushing of only the mixed material from the Mix-Block out to the applicator.

Attached to the outlet of the Mix-Block is the spiral mix tube. This is simply a piece of tubing with a helical-shaped element inside the tube. This element causes the two materials (resin and catalyst) to be ‘folded’ together numerous times as the materials pass through it, thus causing it to mix.



## Relevant Information:

The RansFlow control system achieves closed-loop control of its fluids via its configured channels and guns. A channel consists of one MVR valve (or CCV or inject valve), one flowmeter, one calibration valve, and one check valve. A gun (in most cases) represents one applicator and may be configured with one channel (for dynamic flow control only) or configured with two or three channels (for ratio and flow control). RansPulse controllers only provide ratio control.

Each channel operates independently of, and simultaneously with all of the other channels in the system. The controller, therefore, provides accurate and dynamic flow control for all channels regardless of external system variables (i.e. fluid inlet pressure, backpressure, material viscosity, flowmeter wear, etc.).

## Configurable Operating Parameters:

The design of the RansFlow/RansPulse System allows it to be configured to meet the requirements of the application. The large number of parameters allows the RansFlow to be used in almost any application involving flow and or ratio control of coatings. The RansPulse is only capable of controlling ratio.

**System Parameters** are parameters that affect the overall system, which includes all channels and guns or the user interface. They include:

- Number of guns
- Channels assigned to each gun
- Function of the alarm horn
- Optional Language

**Gun Parameters** are parameters that affect the gun. These parameters apply to all channels configured to that gun. They include:

- Mode (automatic, manual, inject)
- Which channels open during flush sequences
- Default Job Number
- Flow/Ratio Tolerance
- Tolerance Time
- Tolerance Volume
- Flush Mode
- Trigger-On Delay
- Trigger-Off Delay
- Blow-Off Time
- Mixed Volume
- Flush Box Enable/Disable



Gun Parameters Screen

**Channel Parameters** are parameters that affect only that specific channel. For two or three channel guns, there are independent parameters for each of the channels. They include:

- Regulator Type
- MVR High (no effect on RansPulse)
- MVR Low (no effect on RansPulse)
- Pulses/Liter (Flowmeter Calibration Value)
- Pressure Regulator Pressure (no effect on RansPulse)

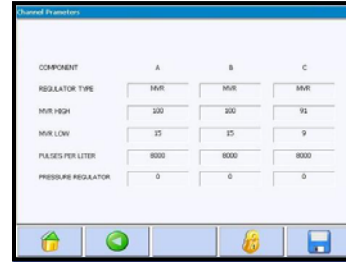

**Advanced Channel Parameters** include:

- Reverse Flow Volume
- C-Band
- I-Band
- Kp
- Ki

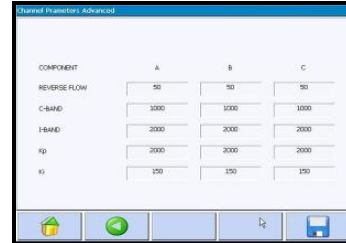

**Job Parameters** are parameters that are stored with the specific job number. Typically, a job number is assigned to a specific material. In this way, totalization data and PID parameters relate directly to the material. These parameters include:

- Flow Rate Setpoint
- Maximum Flow (for analog control)
- Minimum Flow (for analog control)
- Pot-Life Time (in seconds)
- Ratio
- Pulses/Liter (flowmeter calibration values)
- Valve (resin and catalyst)
- MVR High (for each channel)
- MVR Low (for each channel)
- Pressure Regulator Setting (for each channel)
- Kp (for each channel)
- Ki (for each channel)
- C-Band (for each channel)
- I-Band (for each channel)
- Text Notes (for job descriptions)

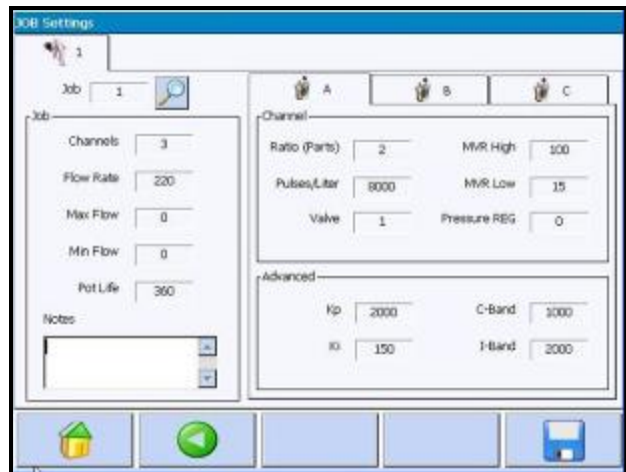

**Job Parameters Screen**

## SPECIFICATIONS - Environmental / Physical

### Size & Weight:

- Main Control Enclosure: 24" Wide x 24" High x 9" Deep.
  - Weight: 31.75 kg ( 70 lbs.)
- Remote Operator Panel: 9.5" Wide x 6.25" High x 4" Deep.
  - Weight: 1.59 kg ( 3.5 lbs.)
- Pneumatic Interface Panel (for second gun): 24" Wide x 12" High x 9" Deep.
  - Weight: 5.44 kg ( 12 lbs.)
- Fluid Panel: 16" Wide x 20" High x 11" Deep.
  - Weight: 15.88 kg ( 35 lbs.)

### Operating Temperature:

- 0-40°C (32°-130°F) inside enclosures

### Operating Humidity:

- 0% to 95% RH

### Power Input:

- 120 VAC, 50/60 Hz @ 2A or
  - 240 VAC, 50/60 Hz @ 1A
- (auto selecting)

### LCD Display:

- 6.5" Diagonal, Full Color, 640 x 480 pixels (utilizing a touchscreen for data input)

### Flow Capacity:

- 10 ml's/min to 4000 ml's/min per channel (dependent upon material and flowmeter limitations)

### Viscosity Range:

- 30 cp to 500 cp

### I/O update time (incl. PID loop):

- 20 millisec (50 times/sec)

### Job Tables:

- 99 Jobs (P-Sets) per gun

## FEATURES

Control of up to 3 materials from one 24" W. x 24" H. x 9" D. Control Enclosure.

Possible gun configurations: (RansFlow)

- One 3-component gun
- One 2-component gun and one single component gun
- Two single component guns

Possible gun configurations: (RansPulse)

- One 3-component gun
- One 2-component gun

Dual channel guns are configurable as manual (ratio control only) or automatic (flow and ratio control) modes for RansFlow but RansPulse can only do ratio control.

Configurable operating parameters for all channels and guns. (Up to 99 'Jobs' per Gun can be programmed.)

Full color 6.5" LCD display with touchscreen for setup, operation, and diagnostics.

Pot-life timer monitoring and alarming.

Wide range of ratio and flow capabilities.

Discrete I/O capabilities allow interfacing to any manufacturer's PLC.

USB port allows backup of all operating parameters, retrieval of flow totalization data, and updating of user-interface software (stored on flash drive). USB flash drive size MUST be less than 4GB.

User interface software is Windows CE based.

Retrofit option allows current EZ Flow, 2k220, 2k880, and DynaFlow customers upgrade their electronics and use their existing fluid components.

Extremely easy to program color change sequencer for flushing and loading can handle up to 10 colors and 3 different catalysts.

All discrete and analog inputs and outputs can be monitored and forced for diagnostic purposes.

Analog input capability for flow rate setpoints (0-10 VDC). [RansFlow only]

Convenient test points on I/O boards make it simple to connect data acquisition hardware for process monitoring and fine tuning.

All discrete inputs and outputs optically isolated.

Gun flush box interface I/O option is available.

Optional inlet pressure control allows users to program inlet fluid pressure to MVR valves. (RansFlow only)

Optional Remote Operator Panel uses Hall-Effect switches and a magnet for operation. (This allows the ROP to be mounted outside the booth on a booth window and operated from inside the booth, eliminating overspray contamination.)

All I/O (including PID loop) are updated 50 times/second.

Extremely robust PID loop is factory tuned for nearly all setups.

## RansFlow SELECTION GUIDE

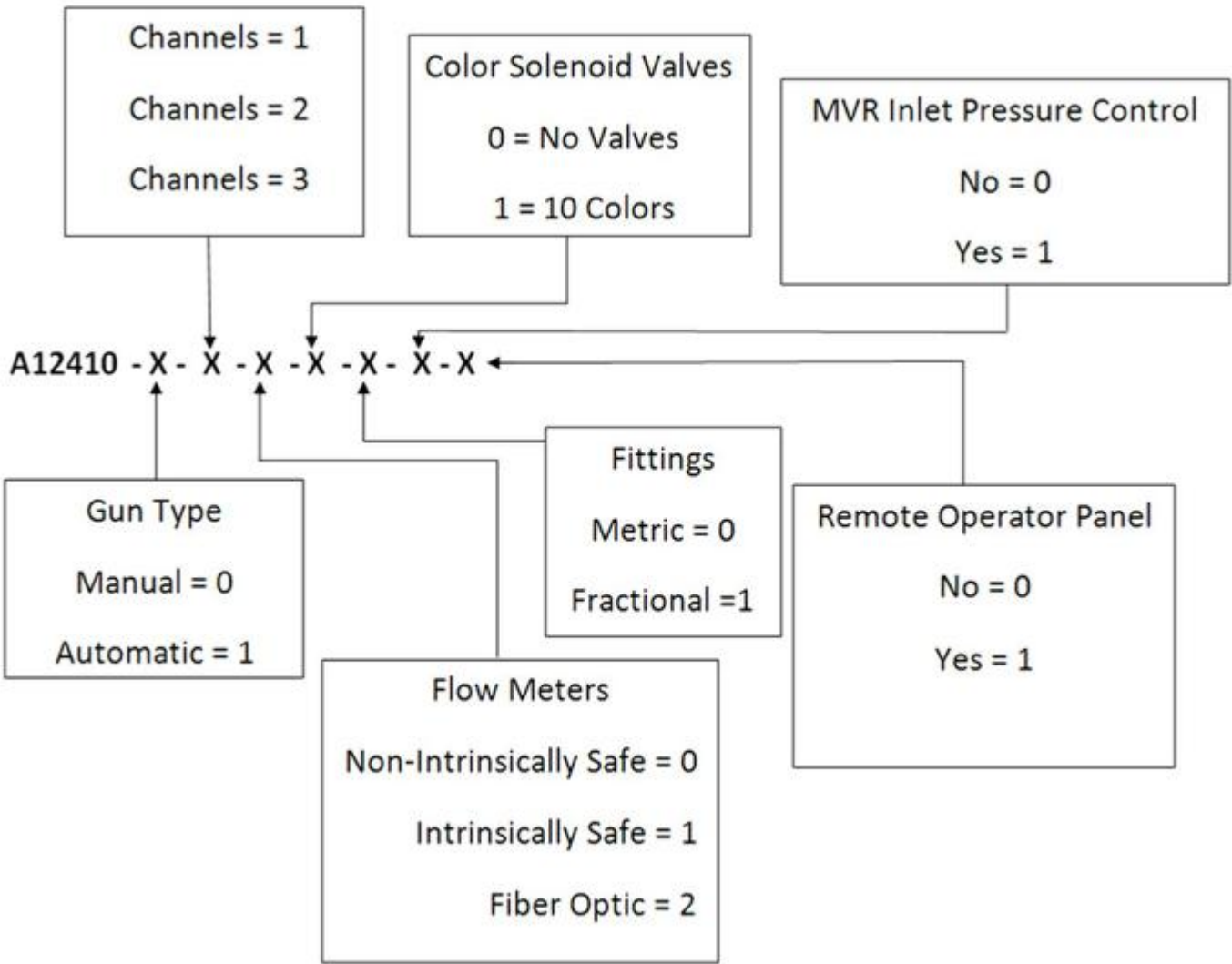

**Control Panel Configuration Part Number**

# RansPulse SELECTION GUIDE

## A 1 3 3 3 4 – A B C D E F

**Number of Colors and Catalysts:**

A = 1: Solenoid valves provided for 1 color & 1 catalyst  
 A = 2: Solenoid valves provided for 10 colors & 3 catalysts

**Number of Channels:**

B = 2: No solenoid valve provided for a 3<sup>rd</sup> channel  
 B = 3: One additional solenoid provided for the 3<sup>rd</sup> channel

**Flowmeter Configuration:**

C = 0: Non-intrinsically safe, non-fiber optic flowmeter interfaces  
 C = 1: Intrinsically safe, non-fiber optic flowmeter interfaces  
 C = 2: Fiberoptic flowmeter interfaces

**Gun Flush Box Interface:**

F = 0: No pressure switches provided  
 F = 1: Two pressure switches provided

**Solenoid Valve Fittings:**

E = 1: English (1/4" ODT push to lock fittings)  
 E = 2: Metric (4mm push to lock fittings)

**Remote Operator Panel:**

D = 0: No remote operator panel  
 D = 1: Non-intrinsically safe remote operator panel  
 D = 2: Intrinsically safe remote operator panel

**Control Panel Configuration Part Number**

## Section 3: INSTALLATION

### System Guidelines:

#### Installation Prints:

Drawings and information contained in this section of the manual are applicable to most installations. However in some special cases, Ransburg may supply custom installation drawings for your specific site. It is highly recommended that if your installation differs significantly from the installation drawings supplied by Ransburg, you notify your Ransburg representative to insure that standard installation practices are not violated and to have your prints updated to reflect the installation accurately for future reference.

#### Cable Assemblies:

Interconnections between all control enclosures and the fluid panels are made using manufactured cable assemblies with heavy duty connectors. This simplifies installation and eliminates the possibility of items being wired incorrectly. The one exception to this is the discrete interface I/O wiring. These connections will vary greatly from installation to installation. This can involve well over 50 connections per control enclosure and, therefore, require a cable with the proper 50-pin connector on one end (P/N: A12487-XXX).

**NOTE:** Any unused conduit holes in the enclosure walls must be blanked off to prevent contaminants from entering the interior of the enclosure.

#### Equipment Grounding:

**CAUTION:** All panels should be grounded in accordance with national and local electrical codes. Refer to the electrical installation drawings provided in this manual to locate the protective grounding terminal for all control panels. If in doubt, contact your Ransburg representative for clarification.

The protective ground conductor must be terminated directly to the protective conductor ground terminal located inside the Control Enclosure marked with this symbol -



#### Equipment Locations:

All of the RansFlow and RansPulse control panels must be located outside of the defined hazardous area. If in doubt, contact your Ransburg representative for clarification.

There are four basic panels used in the RansFlow/RansPulse systems:

- Main Control Enclosure
- Fluid Panel
- Remote Operator's Panel (optional)
- Pneumatic Interface Panel (optional) [Not available on RansPulse]

**Caution:** Do not locate the any of the enclosures near or adjacent to heat producing equipment such as ovens, high wattage lamps, steam pipes, etc.

The Fluid Panel should be placed within 20' of the control enclosure (or Pneumatic Interface Panel in the case of Gun #2) to minimize pneumatic delays between the E to P transducers and the MVR valves. In the case of the RansPulse controller, care should be taken to minimize the distance between the solenoid valves and the injector valves on the fluid panel.

Fluid Regulators:

It is highly recommended that a pilot operated fluid regulator (similar to the DR-1 regulator) be used on the inlet of all of the MVR valves unless they are supplied from pressure pots.

The RansFlow can (optionally) control the pilot pressure to these fluid regulators. (It is sometimes necessary to use higher pressures for high viscosity materials than lower viscosity materials, etc.) The RansFlow allows the user to program a different pressure for every job and every channel so that the inlet pressure to the MVR valves can be fine-tuned to the specific material and flow rate.

Pneumatic Interface Panel for Gun #2: (RansFlow only)

If more than one fluid panel is to be controlled from one RansFlow controller, it is necessary to use a second pneumatic interface panel. In this instance, the software will be configured for two guns, Gun #1 and Gun #2 (See gun configuration chart, below.)

Possible Gun Configurations:

RansFlow:

One 3-channel gun

- Channels 1, 2, & 3

Two single-channel guns

- Gun #1 (Channel 1)
- Gun #2 (Channel 2)

One single-channel gun and one 2-channel gun

- Gun #1 (Channel 1)
- Gun #2 (Channels 2 & 3)

RansPulse:

One 3-channel gun

- Channels 1, 2, & 3

One 2-channel gun

- Channels 1 & 2

**Note:** Channel 3 cannot be configured as a master channel!

**Control / Interface Panel Overview:**

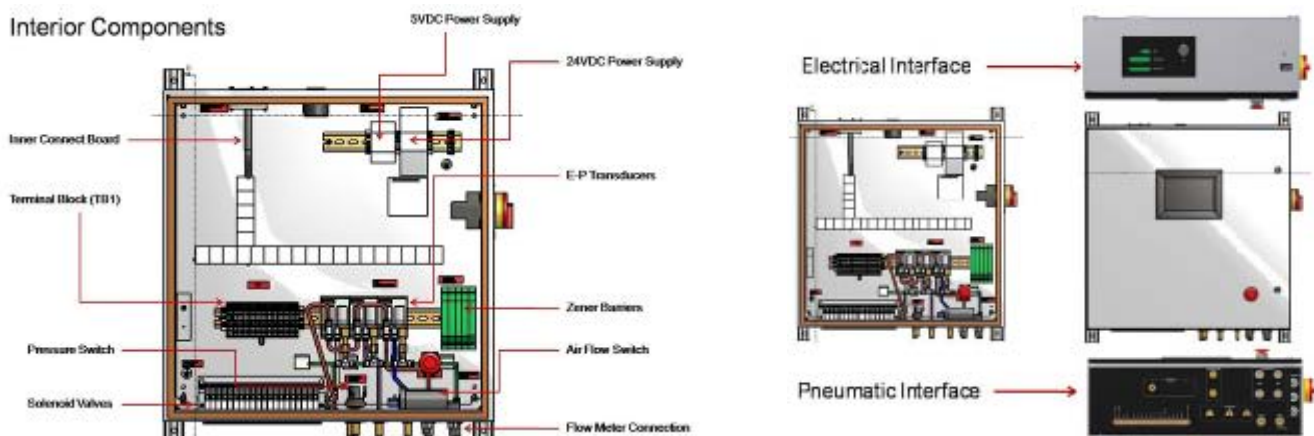



### Equipment Mounting:

Use the mounting ears supplied to mount the control or interface enclosure on a wall or building structure. The anchor system used must be rated to support the specified weight of the enclosure being mounted (see specifications section). When properly mounted, the anchor system shall be capable of withstanding 4 times the rated weight without causing a hazardous condition.

**WARNING:** If improperly located, certain electrical equipment can become a source of ignition and create a risk of fire or explosion. The control and interface enclosures must be located outside of the defined hazardous area (Class 1, Division 1 and 2) for spray finishing of flammable and/or combustible materials. Definitions and requirements for classification of areas are found in the National Electrical Code, NFPA-70, and NFPA-33.

**WARNING:** The control enclosure must be located in such a way that access to the ON/OFF power switch and STOP switch is not blocked. The ON/OFF switch controls AC power to the unit. The stop switch interrupts only the 24VDC to the related interior components and all I/O devices.

### Input Power:

Input supply voltage connections should be made from a FUSED DISCONNECT that is located in an accessible area near the control enclosure.

Electrical conduit is recommended for the input power wiring. Use 3 cond. 14 ga. Wire for the incoming AC power supply.

If using SO type portable cord, a strain relief rated for the diameter of the cord being used is required for protection against cord abrasion and damage.

The protective ground conductor must be terminated directly to the protective conductor ground terminal located inside the Control Enclosure marked with this symbol -



If there are large AC line voltage fluctuations or voltage transients such as those typically produced by heavy machinery or welding equipment, then a constant voltage transformer (CVT) or an uninterruptable power supply (UPS) should be used between the FUSED DISCONNECT and the control enclosure.

**CAUTION:** If a CVT or UPS is used on the input power to the control enclosure, use a CVT with a Volt-Amp (VA) output rating greater than the output voltage multiplied by the control enclosure fuse rating (see specification section). Also be sure the device input ratings correspond with the voltage and frequency of the source power supplied by the FUSED DISCONNECT. The device output should be rated for 240VAC maximum.

**WARNING:** Do not install or service this equipment or perform installation or adjustment procedures unless you are properly trained and qualified. Installing and servicing this equipment requires access to parts which could cause electric shock or serious injury if work is not performed properly. All work must comply with applicable local and national regulations and codes.

## STEP 1 - Main Power to Control Panel Connection



### Electrical Connections – Main Power

1. AC POWER: Cabinet entrance point for incoming AC power.
2. The RansFlow has an auto-switching AC power input that will accept 120-240 VAC.



Proper OSHA Lockout/Tagout procedures must be performed prior to equipment installation or maintenance.



### Electrical connections - Main Power

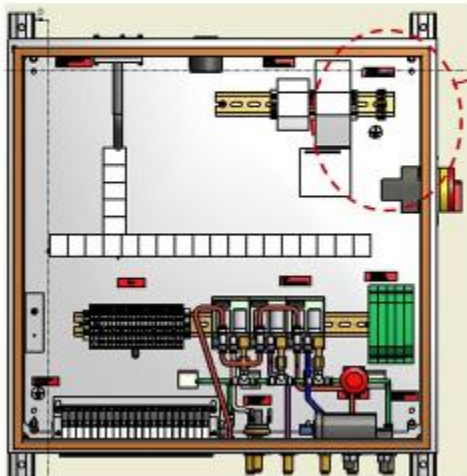

White (neutral)  
Black (hot)  
Green (ground)

#### **CAUTION:**

Wires should be landed on the switch terminal (white & black) and the green wire (ground) directly to the ground block.



## STEP 2 - Flow Meters and I/O Connections

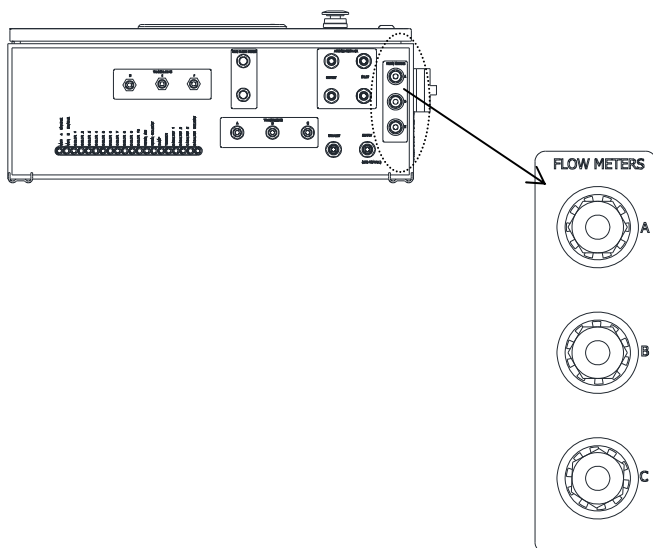

### Electrical Connections - Flow Meters

1. Flowmeters (A B C): Electrical or fiber-optic cable connection point for external flow meters.
2. The RansFlow/RansPulse will support up to 3 flow meters.

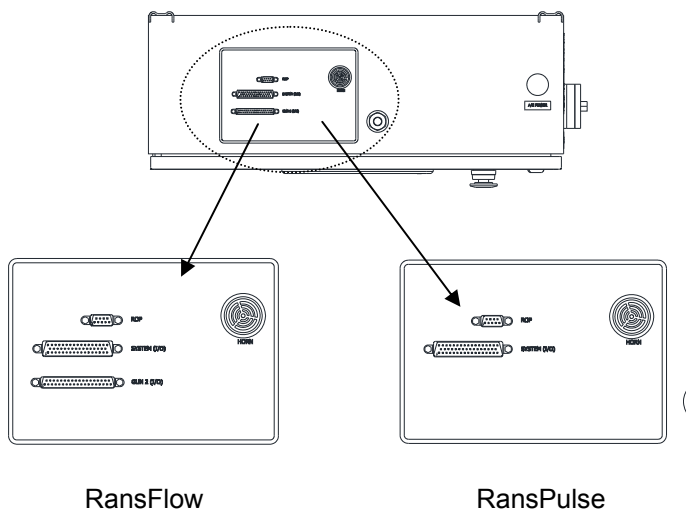

### Electrical Connections - I/O

1. ROP: Connection point for the optional Remote Operator Panel (ROP) cable.
2. System (I/O): I/O cable connection point for external system input and output communication with a PLC or robot (if used).
3. Gun 2 (I/O): I/O connection point to an interface box for an optional second gun. (not available on RansPulse systems)

# STEP 3 - CCV and Gun Connections

## RansFlow Air Connections - CCV and Gun

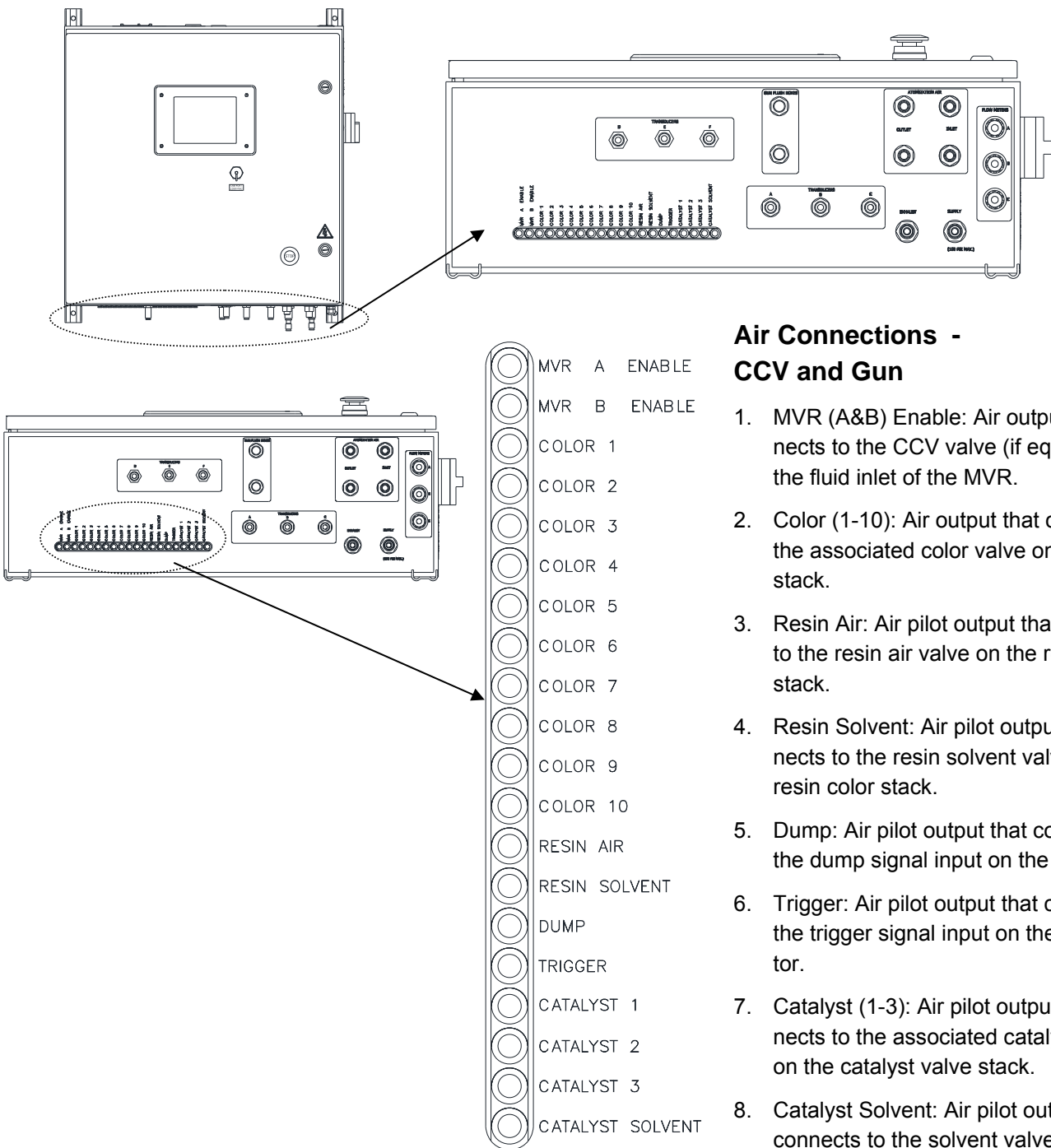

### Air Connections - CCV and Gun

1. MVR (A&B) Enable: Air output that connects to the CCV valve (if equipped) on the fluid inlet of the MVR.
2. Color (1-10): Air output that connects to the associated color valve on the color stack.
3. Resin Air: Air pilot output that connects to the resin air valve on the resin color stack.
4. Resin Solvent: Air pilot output that connects to the resin solvent valve on the resin color stack.
5. Dump: Air pilot output that connects to the dump signal input on the applicator.
6. Trigger: Air pilot output that connects to the trigger signal input on the applicator.
7. Catalyst (1-3): Air pilot output that connects to the associated catalyst valve on the catalyst valve stack.
8. Catalyst Solvent: Air pilot output that connects to the solvent valve on the catalyst valve stack.

# STEP 3 - CCV and Gun Connections

## RansPulse Air Connections - CCV and Gun

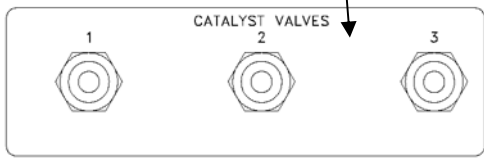
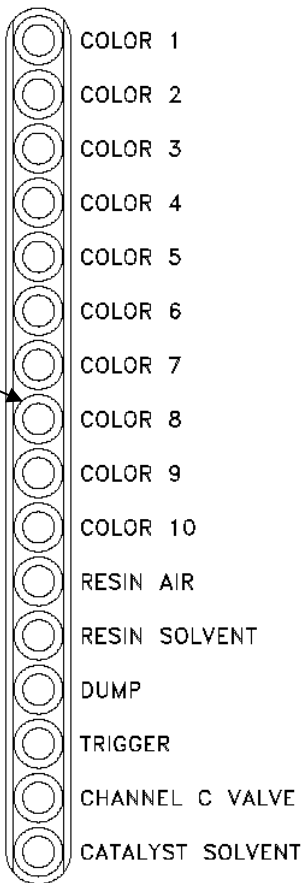
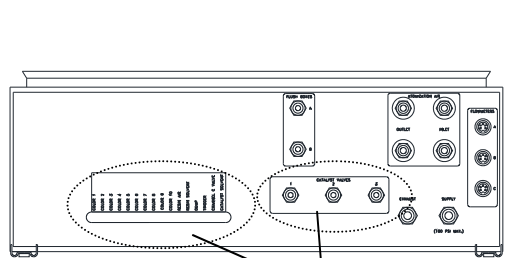
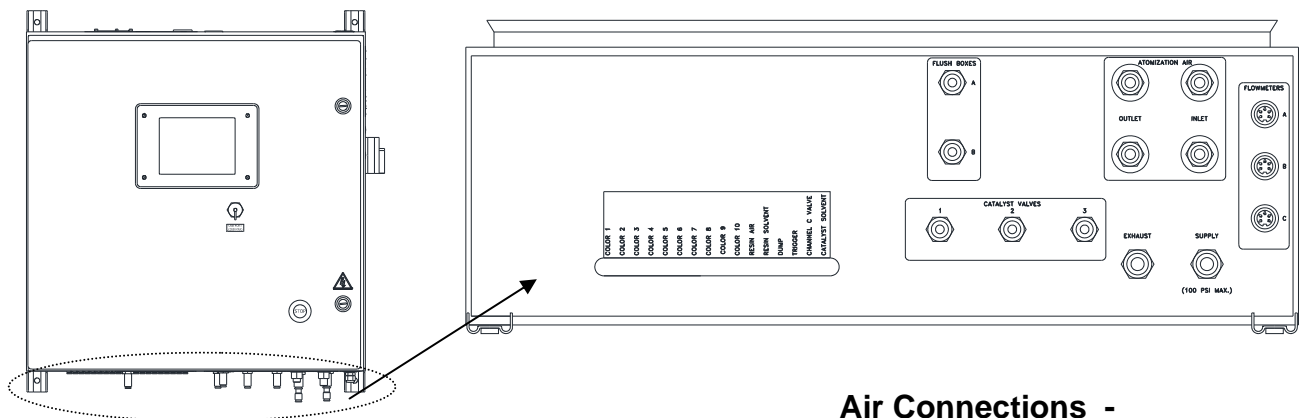

### Air Connections - CCV and Gun

1. Color (1-10): Air output that connects to the associated color valve on the color stack.
2. Resin Air: Air output that connects to the resin air valve on the resin color stack.
3. Resin Solvent: Air output that connects to the resin solvent valve on the resin color stack.
4. Dump: Air output that connects to the dump signal input on the applicator.
5. Trigger: Air output that connects to the trigger signal input on the applicator.
6. Channel C Valve: Output for an optional third channel injector valve.
7. Catalyst Solvent: Air output that connects to the solvent valve on the catalyst valve stack.
8. Catalyst (1-3): Air output that connects to the associated catalyst valve on the catalyst valve stack.

## STEP 4 - Gun Flush Box and Transducer / MVR Connection

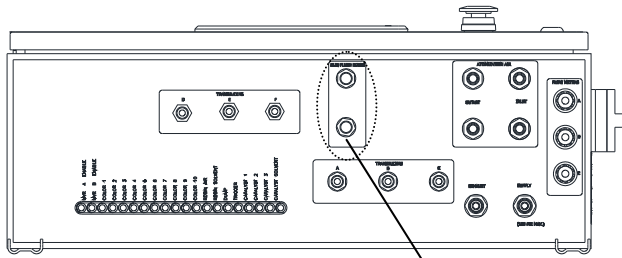

**RansFlow**

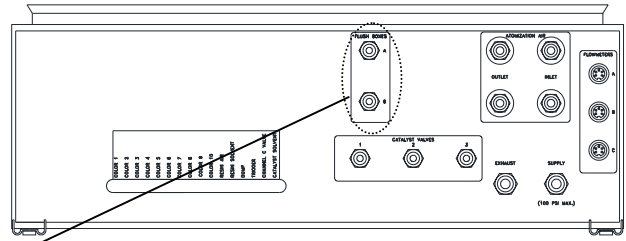

**RansPulse**

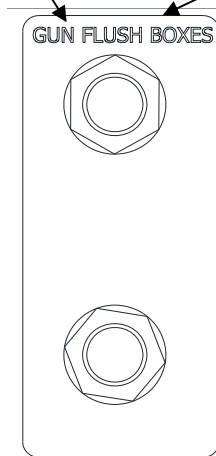

### Air Connections - Gun Flush Box

1. Gun Flush Boxes: This is an air input coming from a gun flush box (if used) verifying that the lid has been closed. Will support up to 2 gun flush boxes. (When enabled, prevents flushes and fills from being initiated if gun is not in flush box and box is closed.)

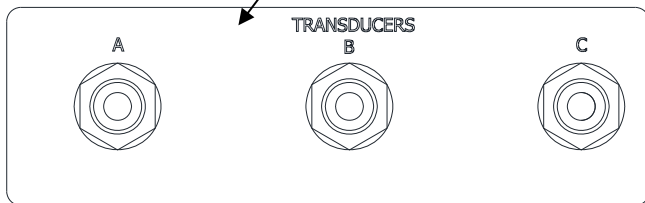
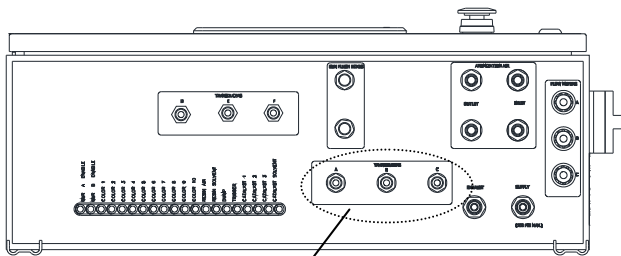

### RansFlow Only

#### Air Connections - Transducer / MVR

1. Transducers (A B C): These are air pilot output connections that connect to the associated air pilot input on the designated Material Valve Regulator (MVR) or fluid regulator.
2. Install following pilot signal tubing guidelines (shown below).
3. The RansFlow will support up to 3 MVRs.

Tubing Size O.D.	Fluid Regulator Type	Typical Application	MIN LENGTH		MAX LENGTH	
			Feet	Meters	Feet	Meters
1/4"	MVR	Two-component	15	4.6	50	15.3
1/4"	DR1	Single-Component	15	4.6	100	30.5

## STEP 5 - Atomization Air and Supply Air Connections

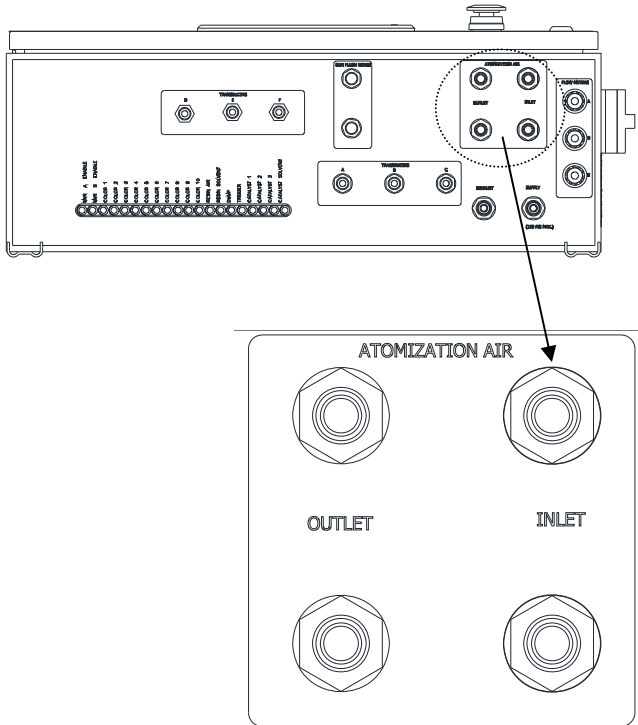

### Air Connections - Atomization Air

1. Atomization Air (Inlet & Outlet): This is an input and output for the gun atomization air. The RansFlow/RansPulse uses this air signal to tell if the gun has been triggered.
2. Connects to an air flow switch inside the RansFlow/RansPulse cabinet.
3. Will support up to 2 guns.

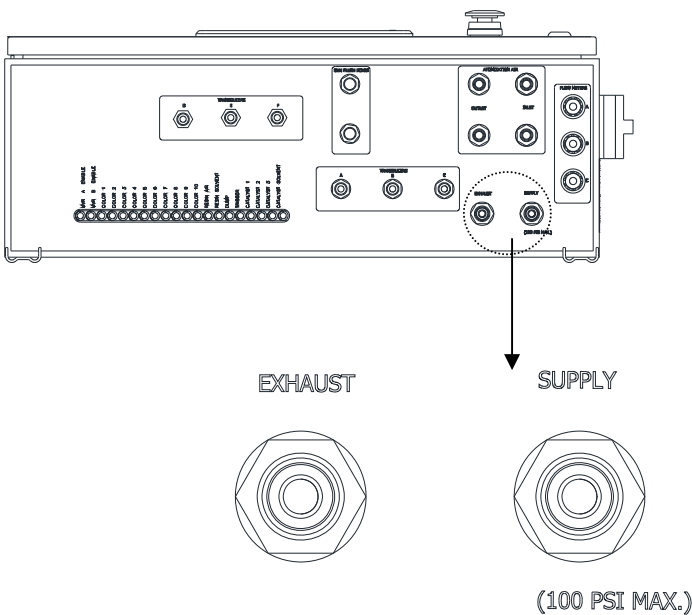

### Air Connections - Supply Air

1. Supply: Air input for control panel main air supply (100 psi maximum).
2. Exhaust: No connection needed here. This is the exhaust for the transducers and solenoids inside the RansFlow/RansPulse cabinet. A muffler is NOT recommended as it restricts the exhaust flow and will reduce the response time of the MVR and solenoid valves.

## STEP 6 - Fluid Connections

### Fluid Panel - Typical 2K Installation

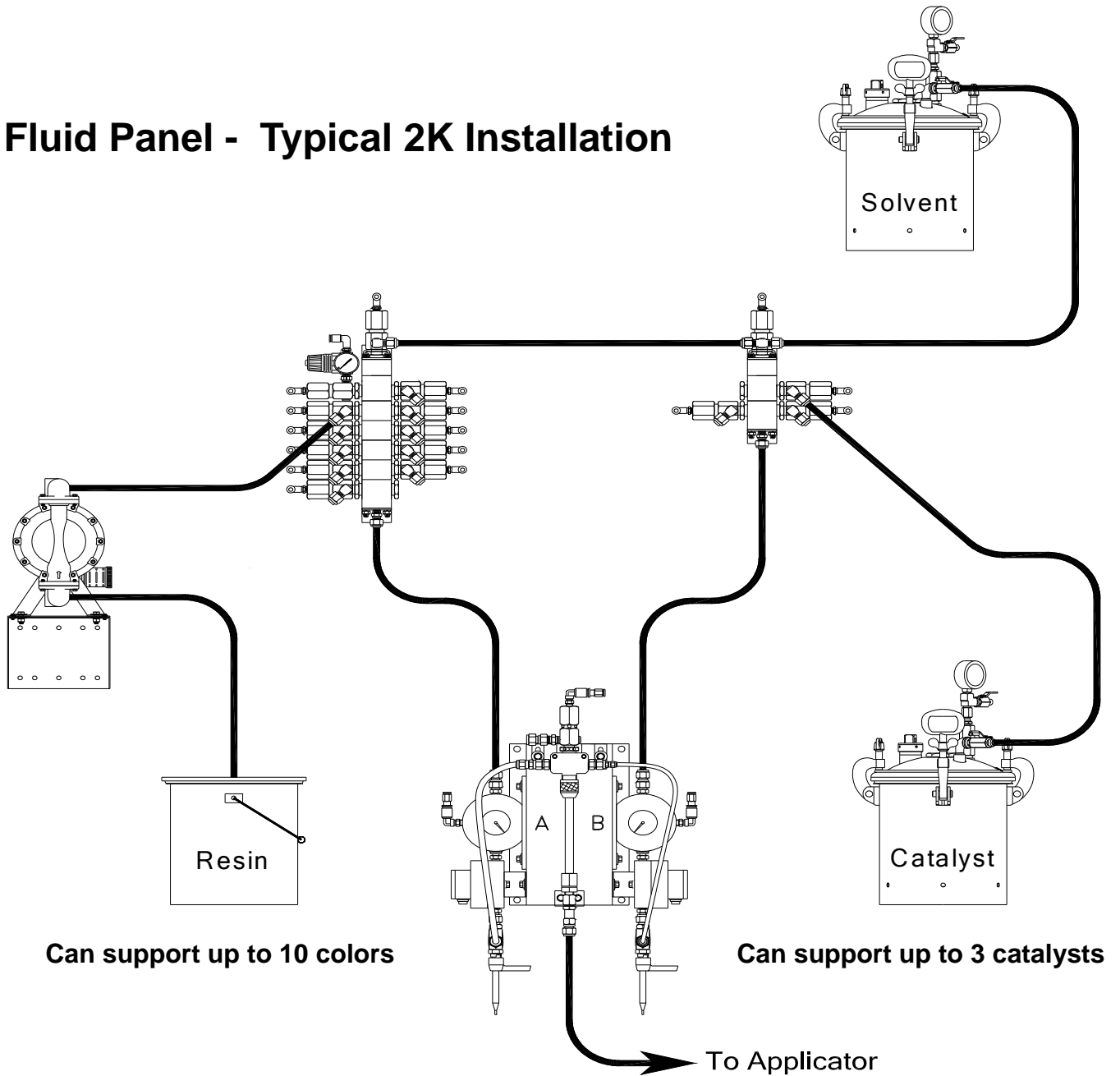



## RansFlow Discrete (Digital and Analog) GUN Inputs and Outputs

<u>Pin No.</u>	<u>Name</u>	<u>Type</u>	<u>Description</u>
1	Resin Air Solenoid	Output	Intended to drive the CCV air valve on the resin color change valve stack assy. It can be programmed to turn on in steps 1 and/or 3 of the flush sequence and it pulses in step 2.
2	Color #9 Solenoid	Output	Intended to drive the #9 color valve on the CCV stack.
3	Color #7 Solenoid	Output	Intended to drive the #7 color valve on the CCV stack.
4	Color #5 Solenoid	Output	Intended to drive the #5 color valve on the CCV stack.
5	Color #3 Solenoid	Output	Intended to drive the #3 color valve on the CCV stack.
6	Color #1 Solenoid	Output	Intended to drive the #1 color valve on the CCV stack.
7	Ch. B Transducer	Output	A 0-10 VDC output command to drive the E to P transducer which, in turn, drives the MVR flow control valve (Ch. B).
8	Resin Solvent Sol.	Output	Intended to drive the CCV solvent valve on the resin color change valve stack assy. It can be programmed to turn on in steps 1 and/or 3 of the flush sequence and it pulses in step 2.
9	Trigger Solenoid	Output	Intended to be shuttled together with the solenoid valve that triggers the applicator during normal spray sequences. It allows the color change sequencer to trigger the applicator during flush and load sequences. (It is turned on in the 3 <sup>rd</sup> step of the load sequence and the 4 <sup>th</sup> step of the flush sequence.)
10	Catalyst #2 Solenoid	Output	Intended to drive the #2 catalyst valve on the catalyst CCV stack.
11	Ch. C Transducer	Output	A 0-10 VDC output command to drive the E to P transducer which, in turn, drives the MVR flow control valve (Ch. C).
12	Flowmeter C Phase	Input	One of the quadrature feedback signals from the channel C flowmeter.
13	Flowmeter A Phase	Input	One of the quadrature feedback signals from the channel A flowmeter.
14	Flowmeter B Phase	Input	One of the quadrature feedback signals from the channel B flowmeter.
15	Flowmeter B Source	Input	One of the quadrature feedback signals from the channel B flowmeter.
16	Trigger	Input	Connecting this input to +24 VDC starts flow on a gun configured in automatic mode.
17	Ch. C MVR Enable	Output	Intended to drive the enable valve on the inlet of the channel C MVR.
18	Ch. A Transducer	Output	A 0-10 VDC output command to drive the E to P transducer which, in turn, drives the MVR flow control valve (Ch. A).
19	+24 VDC	N/A	
20	Color #10 Solenoid	Output	Intended to drive the #10 color valve on the CCV stack.
21	Color #8 Solenoid	Output	Intended to drive the #8 color valve on the CCV stack.
22	Color #6 Solenoid	Output	Intended to drive the #6 color valve on the CCV stack.
23	Color #4 Solenoid	Output	Intended to drive the #4 color valve on the CCV stack.
24	Color #2 Solenoid	Output	Intended to drive the #2 color valve on the CCV stack.

<b>Pin No.</b>	<b>Name</b>	<b>Type</b>	<b>Description</b>
25	Ch. A MVR Enable	Output	Intended to drive the enable valve on the inlet of the channel A MVR.
26	Dump Solenoid	Output	Intended to drive a dump valve at the applicator. On in steps 1 & 2 of the load sequence and steps 1, 2, & 3 of the flush sequence.
27	Catalyst #1 Solenoid	Output	Intended to drive the #1 catalyst valve on the catalyst CCV stack.
28	Catalyst #3 Solenoid	Output	Intended to drive the #3 catalyst valve on the catalyst CCV stack.
29	Cat. Solvent Solenoid	Output	Intended to drive the CCV solvent valve on the catalyst color change valve stack assy. It can be programmed to turn on in step 2 of the flush sequence.
30	Flowmeter C Source	Input	One of the quadrature feedback signals from the channel C flowmeter.
31	DC Common	N/A	DC Common to all I/O signals and DC power supply voltages.
32	Flowmeter A Source	Input	One of the quadrature feedback signals from the channel A flowmeter.
33	DC Common	N/A	DC Common to all I/O signals and DC power supply voltages.
34	Ch. B MVR Enable	Output	Intended to drive the enable valve on the inlet of the channel B MVR.
35	Flush Box "A" Ready	Input	Signal to be on with gun in flush box and flush box lid closed.
36	Flush Box "B" Ready	Input	Signal to be on with gun in flush box and flush box lid closed.
37	+24 VDC	N/A	

## RansFlow Discrete (Digital and Analog) SYSTEM Inputs and Outputs

<u>Pin No.</u>	<u>Name</u>	<u>In or Out</u>	<u>Type</u>	<u>Description</u>
1	Spare	Output	24 VDC	Not currently implemented in software
2	Mixed Volume Cleared, Gun 2	Output	24 VDC	This output goes on when the mixed volume of material has flowed through the flowmeters during the flush cycle.
3	Pressure Regulator, Channel 3	Output	0-10 VDC	This is an analog output programmed in the job parameters intended to drive an E to P transducer to drive a fluid regulator on the inlet of the MVR valve.
4	Pressure Regulator, Channel 2	Output	0-10 VDC	This is an analog output programmed in the job parameters intended to drive an E to P transducer to drive a fluid regulator on the inlet of the MVR valve.
5	Actual Flow, Gun 2	Output	0-10 VDC	Analog indication of actual flow rate. If Min. Flow is programmed at 0 ml's/min and Max. Flow is programmed at 1000 ml's/min and 400 ml's/min is flowing, this output will be at 4.00 volts DC.
6	Flow Rate Command, Gun 2	Input	0-10 VDC	For remote analog control of flow rate. If Min. Flow is programmed at 0 ml's/min and Max. Flow is programmed at 1000 ml's/min and 4.00 volts DC is sent to this input, the gun will flow at 400 ml's/min.
7	Job Select Bit 1, Gun 2	Input	24 VDC	For remote selection of next job to be loaded.
8	Flush, Gun 2	Input	24 VDC	Connecting this input to +24 VDC initiates the flush sequence
9	Halt/Reset, Gun 2	Input	24 VDC	Connecting this input to +24 VDC (momentarily) resets a faulted gun or halts a gun in run (active) mode.
10	Run, Gun 2	Input	24 VDC	Connecting this input to +24 VDC (momentarily) puts a halted (non-faulted) gun in run (active) mode.
11	Job Strobe, Gun 1	Input	24 VDC	For remote selection of next job to be loaded.
12	Job Select Bit 40, Gun 1	Input	24 VDC	For remote selection of next job to be loaded.
13	Job Select Bit 10, Gun 1	Input	24 VDC	For remote selection of next job to be loaded.
14	Job Select Bit 4, Gun 1	Input	24 VDC	For remote selection of next job to be loaded.
15	Job Select Bit 1, Gun 1	Input	24 VDC	For remote selection of next job to be loaded.
16	Flush, Gun 1	Input	24 VDC	Connecting this input to +24 VDC initiates the flush sequence
17	+24 VDC	N/A		
18	H.V. Enable, Gun 2	Output	24 VDC	This output goes on once the load sequence is completed and the gun flush box(es) is/are closed.
19	Fault, Gun 2	Output	24 VDC	This output goes on when the gun faults.
20	Job Strobe, Gun 2	Input	24 VDC	For remote selection of next job to be loaded.
21	Pressure Regulator, Channel 1	Output	0-10 VDC	This is an analog output programmed in the job parameters intended to drive an E to P transducer to drive a fluid regulator on the inlet of the MVR valve.

<b>Pin No.</b>	<b>Name</b>	<b>In or Out</b>	<b>Type</b>	<b>Description</b>
22	Actual Flow, Gun 1	Output	0-10 VDC	Analog indication of actual flow rate. If Min. Flow is programmed at 0 ml's/min and Max. Flow is programmed at 1000 ml's/min and 400 ml's/min is flowing, this output will be at 4.00 volts DC.
23	Flow Rate Command, Gun 1	Input	0-10 VDC	For remote analog control of flow rate. If Min. Flow is programmed at 0 ml's/min and Max. Flow is programmed at 1000 ml's/min and 4.00 volts DC is sent to this input, the gun will flow at 400 ml's/min.
24	Load, Gun 2	Input	24 VDC	Connecting this input to +24 VDC initiates the load sequence
25	Spare	Output	24 VDC	Not currently implemented in software
26	DC Common	N/A		DC Common to all I/O signals and DC power supply voltages.
27	Job Select Bit 80, Gun 1	Input	24 VDC	For remote selection of next job to be loaded.
28	Job Select Bit 20, Gun 1	Input	24 VDC	For remote selection of next job to be loaded.
29	Job Select Bit 8, Gun 1	Input	24 VDC	For remote selection of next job to be loaded.
30	Job Select Bit 2, Gun 1	Input	24 VDC	For remote selection of next job to be loaded.
31	Load, Gun 1	Input	24 VDC	Connecting this input to +24 VDC initiates the load sequence
32	Halt/Reset, Gun 1	Input	24 VDC	Connecting this input to +24 VDC (momentarily) resets a faulted gun or halts a gun in run (active) mode.
33	Run, Gun 1	Input	24 VDC	Connecting this input to +24 VDC (momentarily) puts a halted (non-faulted) gun in run (active) mode.
34	Pot Life Expired, Gun 2	Output	24 VDC	This output is energized when the mixed material in the applicator has been mixed for a time greater than the time programmed in the job parameter for pot-life time.
35	Gun Active, Gun 2	Output	24 VDC	This output is energized if the gun is in run mode or if it is loading or flushing.
36	Job Select Bit 80, Gun 2	Input	24 VDC	For remote selection of next job to be loaded.
37	Job Select Bit 20, Gun 2	Input	24 VDC	For remote selection of next job to be loaded.
38	Job Select Bit 40, Gun 2	Input	24 VDC	For remote selection of next job to be loaded.
39	Job Select Bit 8, Gun 2	Input	24 VDC	For remote selection of next job to be loaded.
40	Job Select Bit 10, Gun 2	Input	24 VDC	For remote selection of next job to be loaded.
41	Job Select Bit 2, Gun 2	Input	24 VDC	For remote selection of next job to be loaded.
42	Job Select Bit 4, Gun 2	Input	24 VDC	For remote selection of next job to be loaded.
43	DC Common	N/A		DC Common to all I/O signals and DC power supply voltages.
44	H.V. Enable, Gun 1	Output	24 VDC	This output is energized once the load sequence is completed and the gun flush box(es) is/are closed.
45	Mixed Volume Cleared, Gun 1	Output	24 VDC	This output is energized when the mixed volume of material has flowed through the flowmeters during the flush cycle.

<u>Pin No.</u>	<u>Name</u>	<u>In or Out</u>	<u>Type</u>	<u>Description</u>
46	Pot Life Expired, Gun 1	Output	24 VDC	This output is energized when the mixed material in the applicator has been mixed for a time greater than the time programmed in the job parameter for potlife time.
47	Gun Fault, Gun 1	Output	24 VDC	This output is energized when the gun faults.
48	Gun Active, Gun 1	Output	24 VDC	This output is energized if the gun is in run mode or if it is loading or flushing.
49	System Pulse	Output	24 VDC	This output pulses on and off at approximately a 1 Hz rate as long as the RansFlow software is running.
50	+24 VDC	N/A		

## RansPulse Discrete (Digital) GUN Inputs and Outputs

<u>Pin No.</u>	<u>Name</u>	<u>Type</u>	<u>Description</u>
1	Resin Air Solenoid	Output	Intended to drive the CCV air valve on the resin color change valve stack assy. It can be programmed to turn on in steps 1 and/or 3 of the flush sequence and it pulses in step 2.
2	Color #9 Solenoid	Output	Intended to drive the #9 color valve on the CCV stack.
3	Color #7 Solenoid	Output	Intended to drive the #7 color valve on the CCV stack.
4	Color #5 Solenoid	Output	Intended to drive the #5 color valve on the CCV stack.
5	Color #3 Solenoid	Output	Intended to drive the #3 color valve on the CCV stack.
6	Color #1 Solenoid	Output	Intended to drive the #1 color valve on the CCV stack.
7	Not Used		
8	Resin Solvent Sol.	Output	Intended to drive the CCV solvent valve on the resin color change valve stack assy. It can be programmed to turn on in steps 1 and/or 3 of the flush sequence and it pulses in step 2.
9	Trigger Solenoid	Output	Intended to be shuttled together with the solenoid valve that triggers the applicator during normal spray sequences. It allows the color change sequencer to trigger the applicator during flush and load sequences. (It is turned on in the 3 <sup>rd</sup> step of the load sequence and the 4 <sup>th</sup> step of the flush sequence.)
10	Catalyst #2 Solenoid	Output	Intended to drive the #2 catalyst valve on the catalyst CCV stack.
11	Not Used		
12	Flowmeter C Phase	Input	One of the quadrature feedback signals from the channel C flowmeter.
13	Flowmeter A Phase	Input	One of the quadrature feedback signals from the channel A flowmeter.
14	Flowmeter B Phase	Input	One of the quadrature feedback signals from the channel B flowmeter.
15	Flowmeter B Source	Input	One of the quadrature feedback signals from the channel B flowmeter.
16	Trigger	Input	Connecting this input to +24 VDC starts flow on a gun configured in automatic mode.
17	Channel C	Output	Intended to drive the Channel C solenoid valve.
18	Not Used		
19	+24 VDC	N/A	
20	Color #10 Solenoid	Output	Intended to drive the #10 color valve on the CCV stack.
21	Color #8 Solenoid	Output	Intended to drive the #8 color valve on the CCV stack.
22	Color #6 Solenoid	Output	Intended to drive the #6 color valve on the CCV stack.
23	Color #4 Solenoid	Output	Intended to drive the #4 color valve on the CCV stack.
24	Color #2 Solenoid	Output	Intended to drive the #2 color valve on the CCV stack.

<u>Pin No.</u>	<u>Name</u>	<u>Type</u>	<u>Description</u>
25	Not Used		
26	Dump Solenoid	Output	Intended to drive a dump valve at the applicator. On in steps 1 & 2 of the load sequence and steps 1, 2, & 3 of the flush sequence.
27	Catalyst #1 Solenoid	Output	Intended to drive the #1 catalyst valve on the catalyst CCV stack.
28	Catalyst #3 Solenoid	Output	Intended to drive the #3 catalyst valve on the catalyst CCV stack.
29	Cat. Solvent Solenoid	Output	Intended to drive the CCV solvent valve on the catalyst color change valve stack assy. It can be programmed to turn on in step 2 of the flush sequence.
30	Flowmeter C Source	Input	One of the quadrature feedback signals from the channel C flowmeter.
31	DC Common	N/A	DC Common to all I/O signals and DC power supply voltages.
32	Flowmeter A Source	Input	One of the quadrature feedback signals from the channel A flowmeter.
33	DC Common	N/A	DC Common to all I/O signals and DC power supply voltages.
34	Not Used		
35	Flush Box "A" Ready	Input	Signal to be on with gun in flush box and flush box lid closed.
36	Flush Box "B" Ready	Input	Signal to be on with gun in flush box and flush box lid closed.
37	+24 VDC	N/A	

## RansPulse Discrete (Digital and Analog) SYSTEM Inputs and Outputs

<u>Pin No.</u>	<u>Name</u>	<u>In or Out</u>	<u>Type</u>	<u>Description</u>
1	Spare	Output	24 VDC	Not currently implemented in software
2	Not Used			
3	Not Used			
4	Not Used			
5	Not Used			
6	Not Used			
7	Job Select Bit 1, Gun 2	Input	24 VDC	For remote selection of next job to be loaded.
8	Not Used			
9	Not Used			
10	Not Used			
11	Job Strobe, Gun 1	Input	24 VDC	For remote selection of next job to be loaded.
12	Job Select Bit 40, Gun 1	Input	24 VDC	For remote selection of next job to be loaded.
13	Job Select Bit 10, Gun 1	Input	24 VDC	For remote selection of next job to be loaded.
14	Job Select Bit 4, Gun 1	Input	24 VDC	For remote selection of next job to be loaded.
15	Job Select Bit 1, Gun 1	Input	24 VDC	For remote selection of next job to be loaded.
16	Flush, Gun 1	Input	24 VDC	Connecting this input to +24 VDC initiates the flush sequence
17	+24 VDC	N/A		
18	Not Used			
19	Not Used			
20	Not Used			
21	Not Used			
22	Not Used			
23	Not Used			
24	Not Used			
25	Spare	Output	24 VDC	Not currently implemented in software
26	DC Common	N/A		DC Common to all I/O signals and DC power supply voltages.
27	Job Select Bit 80, Gun 1	Input	24 VDC	For remote selection of next job to be loaded.
28	Job Select Bit 20, Gun 1	Input	24 VDC	For remote selection of next job to be loaded.
29	Job Select Bit 8, Gun 1	Input	24 VDC	For remote selection of next job to be loaded.
30	Job Select Bit 2, Gun 1	Input	24 VDC	For remote selection of next job to be loaded.



<u>Pin No.</u>	<u>Name</u>	<u>In or Out</u>	<u>Type</u>	<u>Description</u>
31	Load, Gun 1	Input	24 VDC	Connecting this input to +24 VDC initiates the load sequence
32	Halt/Reset, Gun 1	Input	24 VDC	Connecting this input to +24 VDC (momentarily) resets a faulted gun or halts a gun in run (active) mode.
33	Run, Gun 1	Input	24 VDC	Connecting this input to +24 VDC (momentarily) puts a halted (non-faulted) gun in run (active) mode.
34	Not Used			
35	Not Used			
36	Not Used			
37	Not Used			
38	Not Used			
39	Not Used			
40	Not Used			
41	Not Used			
42	Not Used			
43	DC Common	N/A		DC Common to all I/O signals and DC power supply voltages.
44	H.V. Enable, Gun 1	Output	24 VDC	This output is energized once the load sequence is completed and the gun flush box(es) is/are closed.
45	Mixed Volume Cleared, Gun 1	Output	24 VDC	This output is energized when the mixed volume of material has flowed through the flowmeters during the flush cycle.
46	Pot Life Expired, Gun 1	Output	24 VDC	This output is energized when the mixed material in the applicator has been mixed for a time greater than the time programmed in the job parameter for pot-life time.
47	Gun Fault, Gun 1	Output	24 VDC	This output is energized when the gun faults.
48	Gun Active, Gun 1	Output	24 VDC	This output is energized if the gun is in run mode or if it is loading or flushing.
49	System Pulse	Output	24 VDC	This output pulses on and off at approximately a 1 Hz rate as long as the RansFlow software is running.
50	+24 VDC	N/A		

## Section 4: PROGRAMMING

### Main Screen

This is the screen that appears immediately after powering up the RansFlow controller. All data on this screen upon power up is non-valid random data and should be disregarded until a job is loaded from the Emulator Screen.

The icons across the bottom, starting from the left are:

- Configure
- Reports
- Color Change Sequencer
- Tools
- Emulator (Operator Panel)

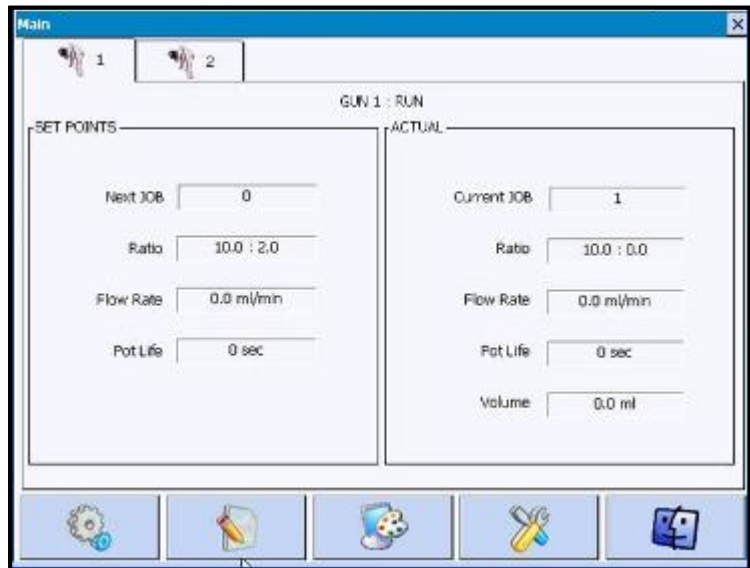

If there is more than one gun configured, there will be two tabs displayed at the top of the screen. Select the gun number you wish to monitor or control. (The second gun option is not available on RansPulse systems.)

Note: The RansFlow can control up to three channels of fluid. They can be configured in any of the following ways:

- One, single channel gun.
- Two, single channel guns.
- One single channel gun and one two component (2-channel) gun. (The 2-channel gun MUST be configured to be channels B & C).
- One three component (3-channel) gun.
- One 2-channel gun (can be configured as channels A & B or B & C if a 3-channel unit was ordered).

Note: The RansPulse can control up to three channels of fluid. They can be configured in any of the following ways:

- One, dual channel gun.
- One, three channel guns.

Immediately below the gun tab (or tabs) there is a gun status line, indicating the status of that gun (i.e. Run, Idle, Faulted, Loading, Flushing, etc.).

## Main Screen (continued)

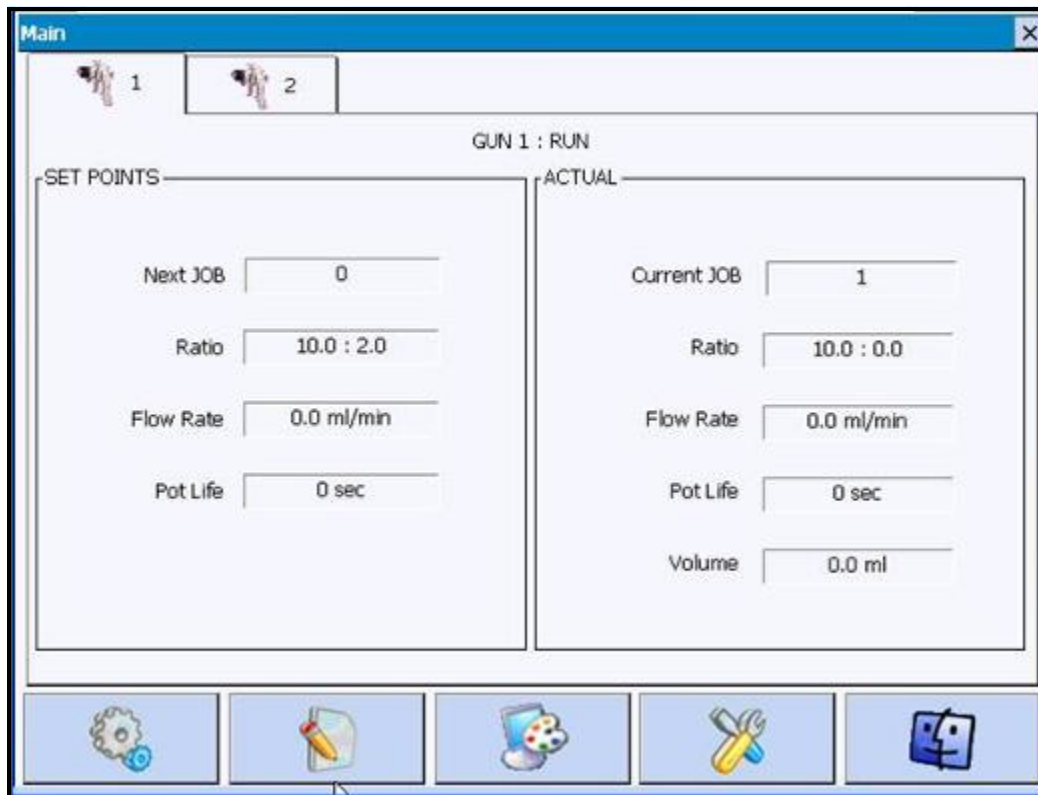

Once a valid job has been loaded, the information in the left column of the Main Screen indicates the targets or setpoints for ratio, flow rate and the pot-life of the material. It also indicates what the next job number to be loaded is (if one was toggled in externally while still running the current job). Note: Flow rate control is not available on the RansPulse.

The ratio and flow rate setpoint can be changed “on the fly” by touching the ratio or flow rate boxes in the left column. A keypad will popup on the screen, allowing the user to change the target ratio or flow rate. This is a temporary change only and is not saved to the job data. This temporary change will be discarded the instant a new job is loaded (even if it is the same job number that is currently running). Note: Flow Rate control is not available on the RansPulse.

In the right column real-time information is provided to allow the user to monitor the current running job number, the actual ratio, the actual flow rate, and the remaining pot-life of the material currently in the applicator. The ratio being displayed is an average over a period of time. If the user wants to get a more instantaneous idea of the ratio, simply touch the volume box in the right column and a small box will popup asking if you would like to reset the volume. If you answer yes, the volume box at the bottom of the column will be zeroed and the ratio being displayed will be averaged once again from that point forward.

## Configure Screen

When you touch the left function button on the main screen, you will be taken to the Configure Selection Screen.

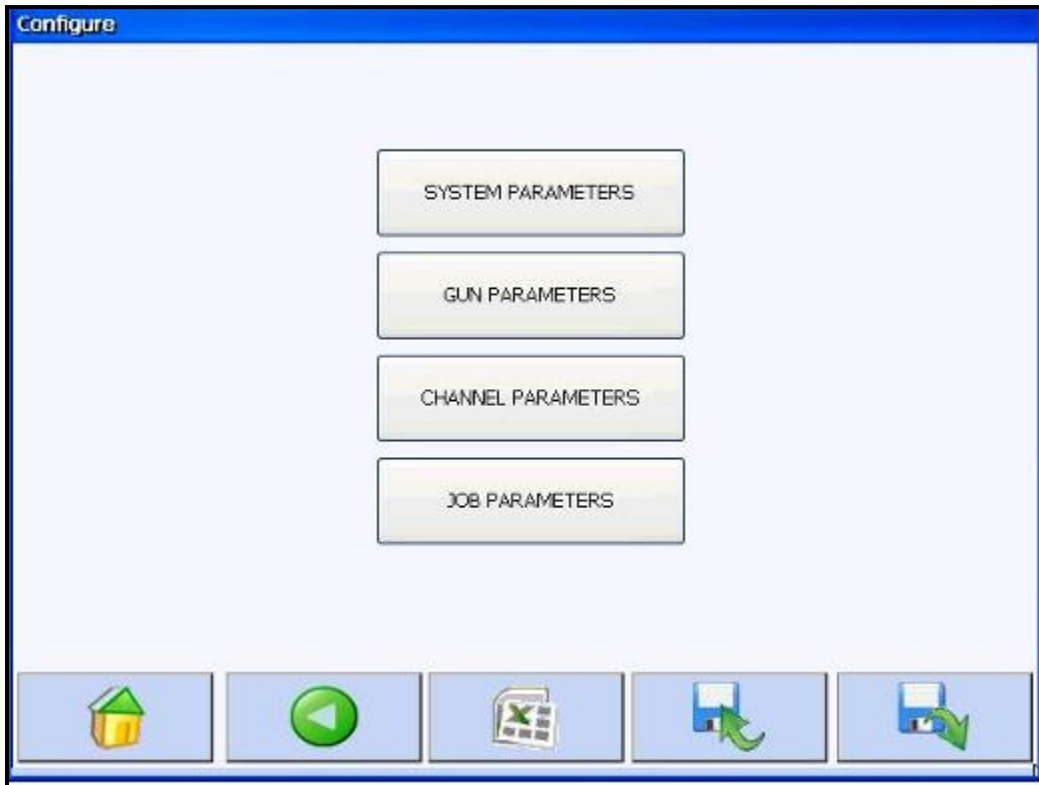

The icons across the bottom of the screen, starting from the left are:

- Return to the Home Screen
- Go back one screen
- Save parameters and/or totalization data to Excel file
- Save Configuration and Job Data (to USB Device). Note: USB flash drive size MUST be 4GB or smaller.
- Read Configuration and Job Data (from USB Port)

Buttons in the center of this screen allow users to select which parameters they wish to examine or edit.

- System Parameters
- Gun Parameters
- Channel Parameters
- Job Parameters

## Configure Screen (continued)

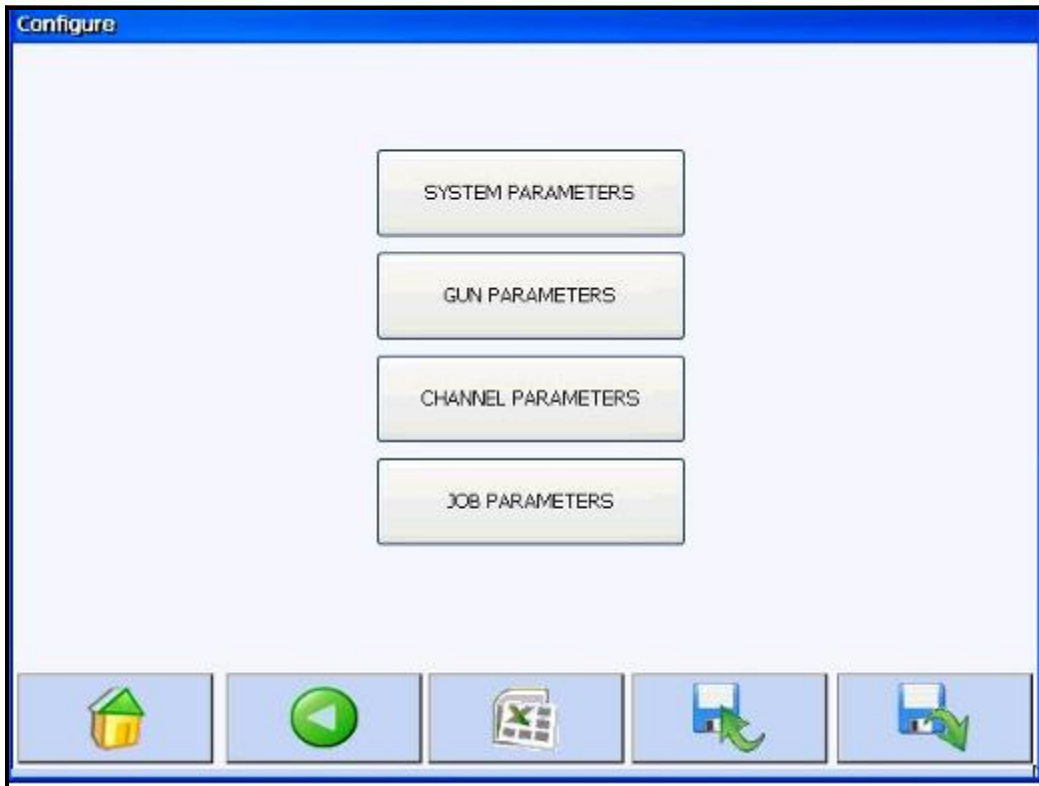

The icon on the middle key:



allows users to save parameters in Excel (comma separated variables, .csv) format to a memory stick and take them to a printer to be printed out. Two files are created, one that has all of the job data and second that has all of the totalization data.

## System Parameters Screen

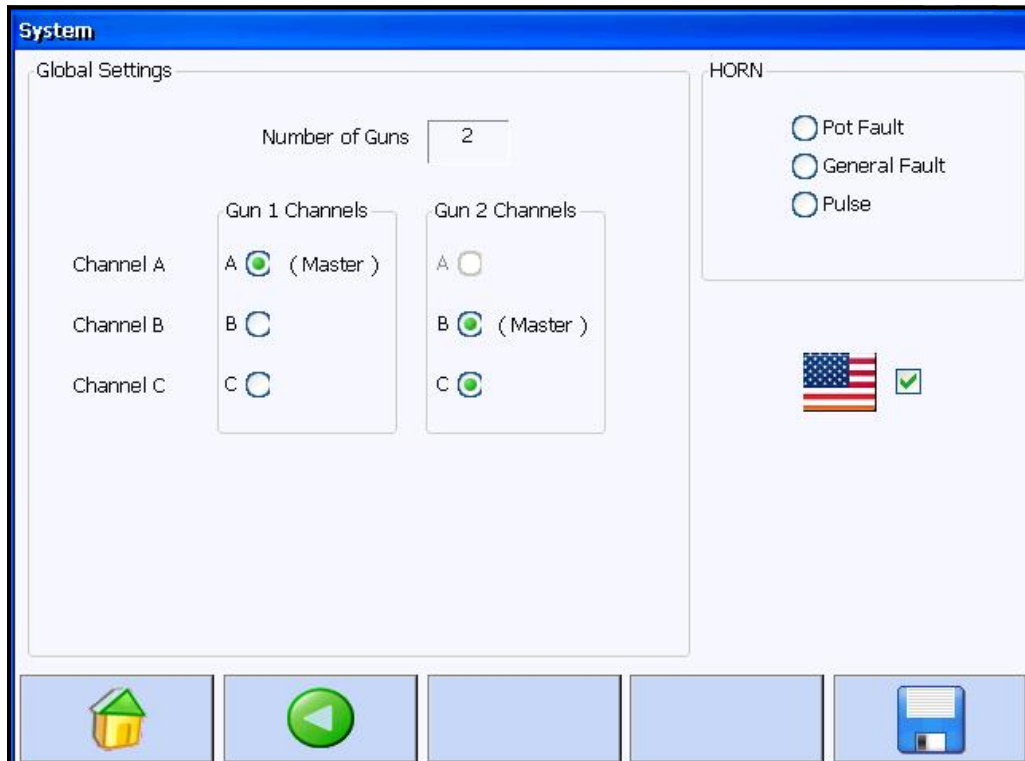

The icons across the bottom of the screen, starting from the left are:

- Return to Home Screen
- Go back one screen
- Not used
- Not used
- Save System Parameters to flash memory

There are only three things that relate to the system that need to be configured:

- The number of guns
- The channels assigned to each gun
- Horn configuration
- Language selection (English plus one alternate language can be configured)

## System Parameters Screen (continued)

The screenshot displays the 'System' configuration interface. It is divided into two main sections: 'Global Settings' and 'HORN'.  
In the 'Global Settings' section, there is a 'Number of Guns' input field set to '2'. Below this are two columns of channel selection for 'Gun 1 Channels' and 'Gun 2 Channels'.  
- Gun 1 Channels: Channel A is selected with a green radio button and labeled '( Master )'. Channels B and C are unselected.  
- Gun 2 Channels: Channel B is selected with a green radio button and labeled '( Master )'. Channels A and C are unselected.  
In the 'HORN' section, there are three radio button options: 'Pot Fault', 'General Fault', and 'Pulse'. The 'Pulse' option is selected.  
Below the radio buttons is an American flag icon with a green checkmark next to it.  
At the bottom of the screen, there is a navigation bar with five icons: a house (Home), a play button (Back), a square (Stop), a square (Forward), and a floppy disk (Save).

The number of guns can only be 1 or 2. As stated previously, a RansFlow can be configured one of five different ways:

- One, single channel gun.
- Two, single channel guns.
- One single channel gun and one two component (2-channel) gun. (The 2-channel gun MUST be configured to be channels B & C).
- One three component (3-channel) gun.
- One 2-channel gun (can be configured as channels A & B or B & C if a 3-channel unit was ordered).

The RansPulse can be configured as:

- One, dual channel gun.
- One, three channel gun.

The radio buttons inside the Horn box allows the user to set when the horn sounds and if the sound will be one continuous tone or a pulsing tone. Options for when the horn sounds are:

- Never
- If a gun fault occurs
- If a pot-life timer expires
- If either a gun fault or pot life timer expires (both radio buttons selected)

## System Parameters Screen (continued)

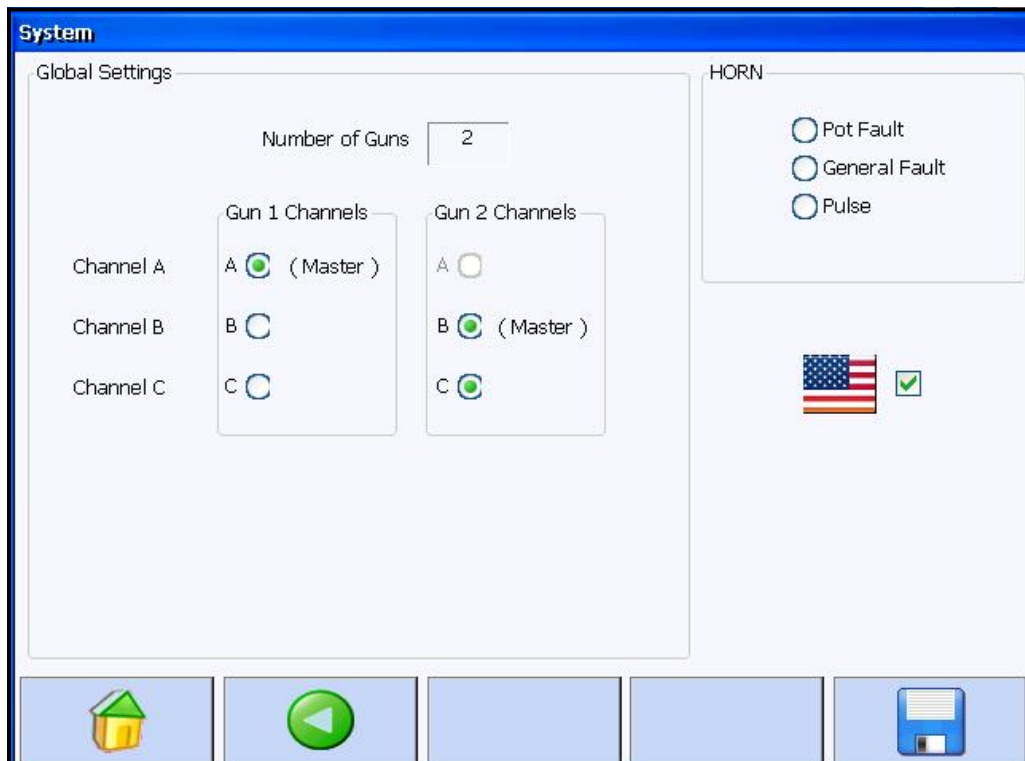

**Note:** If a gun fault occurs (whether or not the horn is configured to sound) the controller turns off all flow control valves configured to that gun. If a pot-life time expires, the controller does not turn off the flow control valves. (This is simply a warning to the user that the material in the applicator is approaching the point where it may coagulate.)

**Note:** If the number of channels configured to a gun changes, it is necessary to reboot the computer (user-interface touch-screen) for the change to take effect.

The RansFlow/RansPulse controllers support English and one other language. When the checkbox next to the American Flag is checked, English will be used for all the interface screens. If this box is unchecked, the alternate installed language will be used. Contact our technical support department on how to install and/or change alternate language files or to find out which alternate languages are available.

Hitting the back button returns you to the Configure Selection Screen.



## Gun Parameters Screen

The screenshot shows the 'Gun Parameters' screen with two tabs labeled '1' and '2'. The '1' tab is selected. The screen displays various parameters for 'GUN 1' in a grid layout. At the bottom, there are five icons: a home icon, a back arrow, two empty boxes, and a save icon.

Parameter	Value	Parameter	Value
CHANNELS	A : :	GUN 1	
MODE	AUTOMATIC	FLUSH MODE	1
CLEAN CHANNELS	YES	TRIGGER-ON DELAY (ms)	0
DEFAULT JOB	1	TRIGGER-OFF DELAY (ms)	0
FLOW TOLERANCE (%)	5	BLOW-OFF TIME (sec)	0
TOLERANCE TIME	3	MIXED VOLUME (ml)	0
TOLERANCE VOLUME	150	Flush Box A	<input type="radio"/>
		Flush Box B	<input type="radio"/>

This screen allows the user to configure parameters specific to the gun.

The icons across the bottom of the screen, starting from the left are:

- Return to Home Screen
- Go back one screen
- Not used
- Not used
- Save Gun Parameters to flash memory

### CHANNELS

This box indicates which channels are configured to the gun. If it is necessary to change this setting, it must be done on the Systems Parameters screen. This information is provided on this screen for informational purposes only.

### MODE

When this box is touched, a popup will allow the user to select either **Manual**, **Automatic**, or **Inject** mode for the gun.

**Note:** (Only Inject mode should be selected for RansPulse units.)

## Gun Parameters Screen (continued)

Gun Parameters

1

2

CHANNELS	A : :		GUN 1
MODE	AUTOMATIC	FLUSH MODE	1
CLEAN CHANNELS	YES	TRIGGER-ON DELAY (ms)	0
DEFAULT JOB	1	TRIGGER-OFF DELAY (ms)	0
FLOW TOLERANCE (%)	5	BLOW-OFF TIME (sec)	0
TOLERANCE TIME	3	MIXED VOLUME (ml)	0
TOLERANCE VOLUME	150	Flush Box A <input type="radio"/>	Flush Box B <input type="radio"/>

In **manual mode**, there is no control of flow on the master channel and the user controls the flow rate either with an external fluid regulator or by adjusting the needle on the applicator. The controller monitors the flow of the master channel and simply controls the ratio of the slave channel or channels based on the programmed ratio. (Note that during the load sequence, if there is a flow control valve on the master channel, the color change sequencer will attempt to control the flow rate of the master channel to prevent flow too high faults as the fluid fills the empty supply lines.)

In **automatic mode**, the controller controls the flow rate and ratio of all channels configured to the gun based on the target flow rate and target ratio.

In **inject mode**, the controller opens the master channel valve as soon as the gun is put in run mode and the slave channel valve (or valves) are pulsed to 'inject' the proper volume of the slave components to maintain the proper ratio.

### **CLEAN CHANNELS**

This allows the user to control which materials are flushed during the color change sequences. If set for No, the color valves and flow control valves will not be opened during the color change sequence. (If disabled, these channels will then have to be manually flushed either by pneumatically bypassing the flow control valves/regulators or by forcing the necessary valves/regulators open on the Force I/O Screen.)

### **DEFAULT JOB**

This is the job that is automatically loaded into the gun at power up. (Note that this only loads the gun parameter data and does not automatically initiate a color load sequence.)

## Gun Parameters Screen (continued)

The screenshot shows the 'Gun Parameters' screen for Gun 1. The screen has a blue header with the title 'Gun Parameters' and two tabs labeled '1' and '2'. Below the tabs, there are several parameter settings:

CHANNELS	A : :	GUN 1			
MODE	AUTOMATIC	FLUSH MODE	1		
CLEAN CHANNELS	YES	TRIGGER-ON DELAY (ms)	0		
DEFAULT JOB	1	TRIGGER-OFF DELAY (ms)	0		
FLOW TOLERANCE (%)	5	BLOW-OFF TIME (sec)	0		
TOLERANCE TIME	3	MIXED VOLUME (ml)	0		
TOLERANCE VOLUME	150	Flush Box A	<input type="radio"/>	Flush Box B	<input type="radio"/>

At the bottom of the screen, there are five buttons: a home icon, a play icon, a blank button, another blank button, and a save icon.

### **FLOW TOLERANCE**

This parameter allows the user to specify how far out of tolerance the flow rate and ratio are allowed to vary before the system generates a fault and closes all valves.

For example:

If flow tolerance is set for  $\pm 5\%$  on a 2-channel gun, with a target flow rate of 150 cc's/min and a 2:1 target ratio, this indicates that the master channel should be flowing at 100 cc's/min and the slave channel should be flowing at 50 cc's/min. So...

#### ***Flow Rate Errors:***

- A flow too low on channel A would occur if the flow rate of A falls below 95 cc's/min.
- A flow too high on channel A would occur if the flow rate of A goes above 105 cc's/min.
- A flow too low on channel B would occur if the flow rate of B falls below 47.5 cc's/min.
- A flow too high on channel B would occur if the flow rate of B goes above 52.5 cc's/min.

(Keep in mind that the flow rate has to remain out of tolerance for the duration of the time programmed for tolerance time.)

## Gun Parameters Screen (continued)

The screenshot shows the 'Gun Parameters' screen for Gun 1. The screen has a blue header with the title 'Gun Parameters'. Below the header, there are two tabs labeled '1' and '2', with '1' selected. The main area contains several parameters with input fields:

CHANNELS	A : :	GUN 1			
MODE	AUTOMATIC	FLUSH MODE	1		
CLEAN CHANNELS	YES	TRIGGER-ON DELAY (ms)	0		
DEFAULT JOB	1	TRIGGER-OFF DELAY (ms)	0		
FLOW TOLERANCE (%)	5	BLOW-OFF TIME (sec)	0		
TOLERANCE TIME	3	MIXED VOLUME (ml)	0		
TOLERANCE VOLUME	150	Flush Box A	<input type="radio"/>	Flush Box B	<input type="radio"/>

At the bottom of the screen, there are five buttons: a home icon, a play button, a blank button, a blank button, and a save icon.

### **Ratio Errors:**

Since a 2:1 ratio results in 66.67% of the channel A material and 33.33% of the channel B material...

- An Out of Tolerance Fault will occur if the actual ratio calculated is greater than 71.67% of the mixed material.
- An Out of Tolerance Fault will occur if the actual ratio calculated is less than 61.67% of the mixed material.

(Keep in mind that the frequency with which this is checked is based on the value programmed for tolerance volume.)

### **TOLERANCE TIME**

This is the amount of time any error (except ratio) must persist before a fault is generated. It is recommended that this never be programmed less than 3 seconds as numerous nuisance faults will probably occur. (Note: Ratio checks are based on volume, not time. See Tolerance Volume below.) This parameter is ignored on guns configured as manual or inject mode.

### **TOLERANCE VOLUME**

This parameter is only used with multiple component guns. Flow rates of all channels are checked 50 times/second (every 20 milliseconds). Ratio, however, is checked based on volume rather than flow rate. Every time one-third of this volume of material has exited the applicator, the controller calculates the actual ratio based on how much of that volume flowed through each of the 2 or 3 channels. If the actual ratio (based on the volumes measured) is outside the flow tolerance setting, a flag is set. If three consecutive flags are set, an Out of Tolerance Fault will occur.

## Gun Parameters Screen (continued)

Gun Parameters			
1		2	
CHANNELS	A : :	GUN 1	
MODE	AUTOMATIC	FLUSH MODE	1
CLEAN CHANNELS	YES	TRIGGER-ON DELAY (ms)	0
DEFAULT JOB	1	TRIGGER-OFF DELAY (ms)	0
FLOW TOLERANCE (%)	5	BLOW-OFF TIME (sec)	0
TOLERANCE TIME	3	MIXED VOLUME (ml)	0
TOLERANCE VOLUME	150	Flush Box A <input type="radio"/>	Flush Box B <input type="radio"/>

### **FLUSH MODE**

Currently there is only one flush and one load sequence saved for all jobs. Therefore, this should always be left at the default value of 1.

### **TRIGGER-ON DELAY (millisec)**

This allows the operator to put a short delay between the time that the controller sees a trigger input signal and when it turns on the flow control valves to start flow. This can be used to prevent flow too low faults if there is a pneumatic delay getting the applicator opened. It is specified in milliseconds. (250 milliseconds = ¼ second) This parameter is ignored on guns configured as manual or inject mode.

### **TRIGGER-OFF DELAY (millisec)**

This allows the operator to put a short delay between the time that the controller sees the trigger input signal go off and when it closes the flow control valves. This prevents the fluid pressure from dropping off while the applicator is closing. This parameter is ignored on guns configured as manual or inject mode.

### **BLOW-OFF TIME (sec)**

This parameter is only functional with manual mode and inject mode guns. This parameter allows a hand painter to blow off a part prior to beginning the spray operation. Note that the timer accumulates until the controller sees flow through the master channel flowmeter.

## Gun Parameters Screen (continued)

**Gun Parameters**

1

2

CHANNELS	<input type="text" value="A : :"/>		GUN 1
MODE	<input type="text" value="AUTOMATIC"/>	FLUSH MODE	<input type="text" value="1"/>
CLEAN CHANNELS	<input type="text" value="YES"/>	TRIGGER-ON DELAY (ms)	<input type="text" value="0"/>
DEFAULT JOB	<input type="text" value="1"/>	TRIGGER-OFF DELAY (ms)	<input type="text" value="0"/>
FLOW TOLERANCE (%)	<input type="text" value="5"/>	BLOW-OFF TIME (sec)	<input type="text" value="0"/>
TOLERANCE TIME	<input type="text" value="3"/>	MIXED VOLUME (ml)	<input type="text" value="0"/>
TOLERANCE VOLUME	<input type="text" value="150"/>	Flush Box A <input type="radio"/>	Flush Box B <input type="radio"/>

The reason this is important is that there is the possibility that the gears in the master channel flowmeter could become stuck. If this occurs, material can slip by the gears without the gears turning. As a result, there is no signal fed back to the controller and it has no way of knowing that master channel component is flowing. The controller, therefore, does not meter in any of the slave component or components. This results in only a single component material being applied to the parts. When an air flow switch is used, the controller will monitor this signal. If it sees a trigger signal for a period of time longer than that programmed in for Blow Off Time, it will generate a No Master Flow Fault and shut down the system, thus preventing non-catalyzed material from being applied to the product. (The Air Blow Off Time parameter is provided for users that wish to partially trigger the gun and blow dust, debris, water, etc. off of the parts prior to spraying.)

The system can be operated without the trigger signal (the slave channel or channels are controlled based on the flow rate of the master) but this is not recommended. Two trigger switches are provided. However, if more than two applicators are connected to the output of the fluid panel, the trigger signals from all applicators should be paralleled and fed back to the trigger input of the controller. Note that this may require a diode array to prevent feeding back voltage to the triggering devices. If you are unsure how to implement this scheme, contact your Ransburg representative or our technical support group.

**NOTE:**

It is highly recommended that all handguns have air flow switches attached to the atomization airline feeding the handgun. The signal from that air flow switch should be wired back to the trigger input of the controller (System I/O connector) if the factory installed air flow switch is NOT being used. If the air flow switches located in the control console are to inconvenient to be hosed to the gun(s), an optional remote trigger switch box is available. Order P/N 77033.

## Gun Parameters Screen (continued)

The screenshot shows the 'Gun Parameters' screen with two tabs labeled '1' and '2'. The '1' tab is selected. The screen displays the following parameters and their values:

CHANNELS	A : :	GUN 1	
MODE	AUTOMATIC	FLUSH MODE	1
CLEAN CHANNELS	YES	TRIGGER-ON DELAY (ms)	0
DEFAULT JOB	1	TRIGGER-OFF DELAY (ms)	0
FLOW TOLERANCE (%)	5	BLOW-OFF TIME (sec)	0
TOLERANCE TIME	3	MIXED VOLUME (ml)	0
TOLERANCE VOLUME	150	Flush Box A <input type="radio"/>	Flush Box B <input type="radio"/>

At the bottom of the screen, there are five icons: a house (Home), a play button (Run), a square (Stop), a square (Pause), and a floppy disk (Save).

### MIXED VOLUME (ml)

This volume represents the volume of material in the system that has been mixed. It, basically, is all of the material between the top of the spiral mix tube and the applicator or applicators. It is calculated based on the inside diameter of the fluid lines and their lengths. Use the following formula to calculate this value:

$$\text{Volume (ml)} = d^2 \times L \times 12.87$$

Where:

d = the inside diameter of the tubing (in inches)

L = the length of the tubing (in inches)

Also add in the appropriate volumes for the spiral mix tube and the applicator or applicators.

### Flush Box A and B Radio Buttons

In the lower right hand corner of the screen are two radio buttons, one labeled Flush Box A and the other Flush Box B. There are two pressure switches in the bottom of the control enclosure that have been provided to interface with gun flush boxes. If these radio buttons are enabled on this screen, the color change sequencer will not be allowed to operate unless a signal is coming into the pressure switch or switches that are enabled on this screen. (Pressure on the switch indicates to the software that the applicator or applicators are in the flush box, that the flush box is closed, and that the high voltage power supply, if used, is disabled.)

Once all of these parameters meet your requirements, make sure you touch the save button in the bottom right hand corner of the screen to save the parameters to the flash disk. If the disk is greyed out it indicates that the gun is either in run mode or it is faulted. Parameters can not be saved in either of these states.

## Channel Parameters Screen

Return to the previous screen (Configure Selection Screen) and select Channel Parameters.

COMPONENT	A	B	C
REGULATOR TYPE	MVR	MVR	MVR
MVR HIGH	100	100	91
MVR LOW	15	15	9
PULSES PER LITER	8000	8000	8000
PRESSURE REGULATOR	0	0	0

The bottom of the screen features five icons: a house (Home), a left arrow (Back), an empty box (Not used), a lock (Advanced Channel Parameters), and a diskette (Save).

The icons across the bottom of the screen, starting from the left are:

- Return to Home Screen
- Go back one screen
- Not used
- Advanced Channel Parameters
- Write displayed parameters to operating gun (these parameters will not be saved to flash memory!)

**Note:** All channel parameters displayed on this screen and the advanced channel parameters (accessed by touching the lock symbol) are for temporary changes only (except for the Reverse Flow parameter on the Advanced Screen). When any of these parameters are changed and then saved by touching the diskette symbol, the data is changed for the job currently running ('on the fly') but are not saved to the job. Therefore, when a new job is loaded (even if it is the same job currently running), the data programmed in the job file will over write these temporary parameters.

Since this is the only place to modify the Reverse Flow Parameter, when the save button is pressed, this parameter is saved to flash memory and is permanent for all jobs until, once again, changed on this screen. **Any other changes that are intended to be permanent must be made on the Edit Job Data Screen.**

**Note:** When making changes to the parameters on this screen, they have to be saved with the button in the lower right corner of the screen (the disk icon) before they temporarily take effect. They do not take effect when the enter key is pressed on the keypad!



## Channel Parameters Screen (continued)

COMPONENT	A	B	C
REGULATOR TYPE	MVR	MVR	MVR
MVR HIGH	100	100	91
MVR LOW	15	15	9
PULSES PER LITER	8000	8000	8000
PRESSURE REGULATOR	0	0	0

Navigation icons: Home, Play, Lock, Save

### **REGULATOR TYPE**

This parameter allows the user to specify what type of flow control device is being used on that specific channel. This is a label ONLY and has NO EFFECT on the operation of the system.

### **MVR HIGH**

This parameter allows the user to temporarily limit the maximum pressure that is sent to the flow control device from the E (voltage) to P (pressure) transducer. This pressure is used for flush sequences and for opening the master channel on a gun configured for manual operation. (This parameter is ignored on RansPulse units.)

### **MVR LOW**

This parameter allows the user to temporarily change the cracking pressure of the flow control valve. This parameter should be programmed just below the cracking pressure to prevent leakage of material past the flow control valve when the gun is triggered off. This will result in the fastest possible response in the flow control loop when switching from a no-flow state to a flow-state. A value of 20 psi is recommended for weep-style MVR valves and 10 psi is recommended for the weepless-style MVR valves. (This parameter is ignored on RansPulse units.)

## Channel Parameters Screen (continued)

Channel Parameters	A	B	C
COMPONENT			
REGULATOR TYPE	MVR	MVR	MVR
MVR HIGH	100	100	91
MVR LOW	15	15	9
PULSES PER LITER	8000	8000	8000
PRESSURE REGULATOR	0	0	0

Navigation icons: Home, Play, Lock, Save

### PULSES PER LITER

This parameter allows the operator to view or temporarily change the calibration values for the flowmeters. This is normally done through the calibration routine.

### PRESSURE REGULATOR

This allows the operator to temporarily change the pressure being delivered to a pilot operated fluid regulator on the inlet of the flow control valve for each channel. (Typically, thicker materials require a higher inlet pressure to the flow control valve.) Note that the hardware to do this is optional. (This feature is not available on RansPulse units.)

## Advanced Channel Parameters Screen

The screenshot shows a screen titled "Channel Parameters Advanced" with a table of parameters. The table has columns for COMPONENT, A, B, and C. The parameters listed are REVERSE FLOW, C-BAND, I-BAND, Kp, and Ki. Each parameter has a corresponding input field for each component, all containing the same numerical value.

COMPONENT	A	B	C
REVERSE FLOW	50	50	50
C-BAND	1000	1000	1000
I-BAND	2000	2000	2000
Kp	2000	2000	2000
Ki	150	150	150

At the bottom of the screen, there are five icons: a house icon (Home), a green play button (Back), an empty box, a mouse cursor icon (Not used), and a floppy disk icon (Save).

(Note that this screen is accessed by touching the lock symbol on the Channel Parameters Screen.)

The icons across the bottom of the screen, starting from the left are:

- Return to Home Screen
- Go back one screen
- Not used
- Not used
- Write displayed parameters to operating gun (these parameters will not be saved to flash memory!)

### **REVERSE FLOW**

This parameter allows the user to control how much flow in the reverse direction is allowed before a fault is generated and the system is shut down. Note that programming a value of zero (0) here is not recommended because there is some unavoidable reverse flow that occurs because of hydrostatic kickback when some applicators turn their trigger valves off. The default value of 50 cc's works well in most cases. Note: This is the only parameter on this screen that is saved to flash memory and used on all future loaded jobs. All other parameters when changed on this screen are temporary only and will revert back to the values stored with the job when the next job is loaded.

## Advanced Channel Parameters Screen (continued)

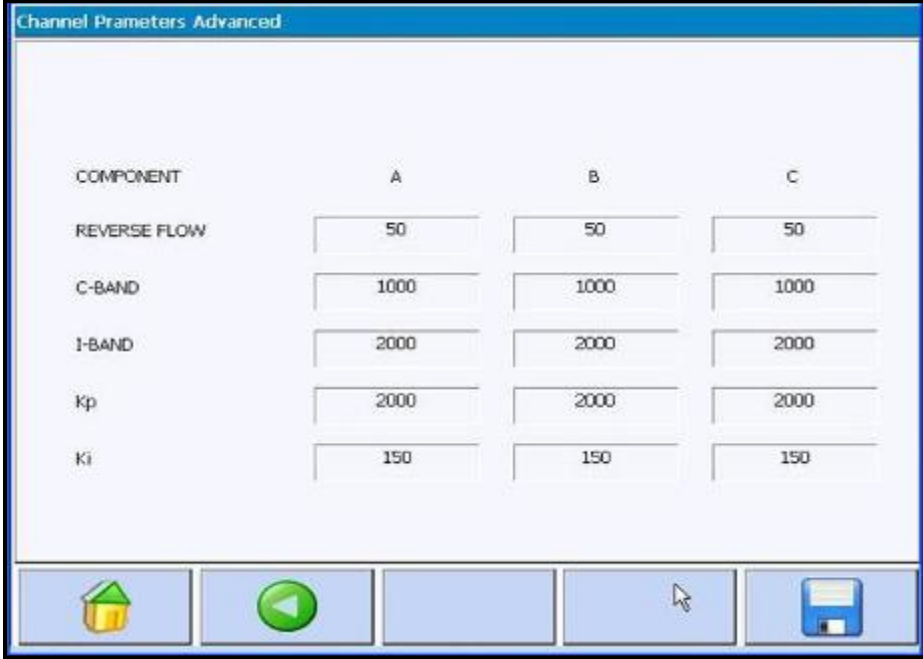

The screenshot shows a software interface titled "Channel Parameters Advanced". It contains a table with three columns labeled A, B, and C, and six rows of parameters. Each parameter has a corresponding input field with a numerical value. At the bottom of the screen, there is a navigation bar with five icons: a house, a play button, a blank box, a mouse cursor, and a floppy disk.

COMPONENT	A	B	C
REVERSE FLOW	50	50	50
C-BAND	1000	1000	1000
I-BAND	2000	2000	2000
Kp	2000	2000	2000
Ki	150	150	150

### **C-BAND**

This is the control band for the PID control loop. In general, this setting should never need to be changed unless the flow meter has been changed to a flow meter with a significantly different calibration value. This parameter keeps the system steady while maintaining a constant flow rate. Too large a value can keep the system from getting to the target flow rate while too small a value may cause the flow rate to oscillate. A value of 1000 works well in most cases.

### **I-BAND**

This is the integrator band for the PID control loop. In general, this setting should never need to be changed unless the flowmeter has been changed to a flowmeter with a significantly different calibration value. This parameter controls how responsive the system is when the desired flow rate changes. Too large a value will cause the system to overshoot the target flow while too small a value may prevent the system from reaching the target flow rate or possibly even cause the flow rate to oscillate. A value of 2000 works well in most cases.

### **Kp**

This is the Proportional Gain parameter for the PID loop. It controls how fast the PID loop opens the flow control valve when flow is initially requested. A value too small here will cause an unnecessary delay in flow on the initial trigger on of the applicator or a slow ramp up of flow. Too large of a value here will cause the flow to oscillate. The default value of 2000 works well in most cases.

### **Ki**

This is the Integral Gain parameter for the PID loop. It controls how fast the PID loop pulls the actual flow back to the target flow after the proportional portion of the PID loop gets the actual flow close to the target. A value of 150 works well in most cases.

## Job Parameters Screen

Return to the previous screen (Configure Selection Screen) and select Job Parameters.

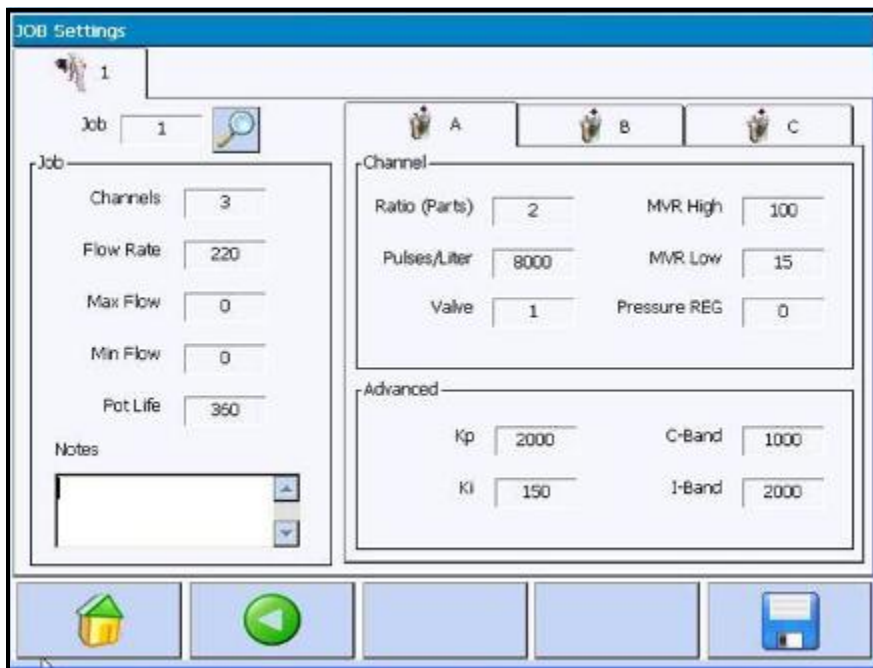

**Note:** If you change any of the parameters on this screen for the job number that is currently running, they will not change the parameters currently running. To actually change parameters that are currently running, the job must be reloaded from the Emulator Screen after the changes to the Job Parameters Screen have been saved.

This is the screen where all of the parameters stored with the “Job” are examined, modified, and saved.

The icons across the bottom of the screen, starting from the left are:

- Return to Home Screen
- Go back one screen
- Not used
- Not used
- Save Job Parameters to flash memory

If two guns are configured, there will be two gun tabs at the top of the screen. Select the gun number that you wish to examine or edit.

Notice the small magnifying glass immediately to the right of the Job number box. This button allows you to “Examine” parameters for any job and edit them, if necessary. For example, if you wanted to examine and edit parameters for job number 22, touch the small box immediately to the right of the word Job. A keypad will pop up and allow you to enter a job number. (Valid job numbers range from 1 to 99.) Enter the number 22 (or whatever job you wish to examine/edit) and touch the enter (ENT) key and then touch the magnifying glass to retrieve the values. If a valid job #22 was previously stored, its parameters will be displayed. If that job number is not in memory, the job number will change to 0, indicating that this job number has not yet been saved in memory.

## Job Parameters Screen (continued)

The screenshot shows the 'JOB Settings' interface. At the top, 'Job 1' is selected. Below this, there are several input fields: 'Channels' (3), 'Flow Rate' (220), 'Max Flow' (0), 'Min Flow' (0), and 'Pot Life' (360). A 'Notes' field is also present. On the right, there are three channel tabs labeled 'A', 'B', and 'C'. Under 'Channel A', parameters are: 'Ratio (Parts)' (2), 'Pulses/Liter' (8000), 'Valve' (1), 'MVR High' (100), 'MVR Low' (15), and 'Pressure REG' (0). Under 'Advanced', parameters are: 'Kp' (2000), 'Ki' (150), 'C-Band' (1000), and 'I-Band' (2000). At the bottom, there are five buttons: a home icon, a play button, a magnifying glass, a save button (diskette icon), and a save button (diskette icon).

Modify the parameters as necessary. (Don't forget to modify all channels with the channel tabs on the right section of the screen.) If you want to save the parameters to the job number currently being displayed in the job number box, simply touch the save button. (The save button is in the lower right corner and has a diskette icon in it.) If you wish to save the displayed parameters to a different job number (or if the job number displayed is 0), change the number in the job number box to the desired value and then touch the save button. Jobs can be copied by entering the source job number in the box, retrieving its data with the magnifying glass button, entering the destination job number in the job box, than touching the save button.

### Channels

This value is not adjustable on this screen, it appears for informational purposes only. Channels and guns are configured on the System Parameters screen. This box simply indicates how many channels are configured to the gun. The number of channel tabs on the right side of the screen will match this number. Make sure all parameters for all channels are programmed.

### Flow Rate

This is the target flow rate for the gun. If the gun is configured as a manual mode gun, this parameter is ignored. If analog flow control is to be used, this value should be 0. (That is, this value overrides the Min Flow and Max Flow settings.) It is expressed in ml's/min (cc's/min). This parameter is ignored if the gun mode is manual or inject (i.e. RansPulse units).

### Max Flow

This parameter is the target flow rate desired from the applicator when a 10 VDC signal is received at the analog flow rate input. It is expressed in ml's/min (cc's/min). This parameter is ignored if the gun mode is manual or inject (i.e. RansPulse units).

## Job Parameters Screen (continued)

The screenshot shows the 'JOB Settings' interface. At the top, 'Job 1' is selected. Below this, there are three tabs labeled 'A', 'B', and 'C'. The 'Job' section on the left contains the following parameters: Channels (3), Flow Rate (220), Max Flow (0), Min Flow (0), and Pot Life (360). There is also a 'Notes' field with a text area and scroll arrows. The 'Channel' section on the right contains: Ratio (Parts) (2), MVR High (100), Pulses/Liter (8000), MVR Low (15), and Valve (1). The 'Advanced' section contains: Kp (2000), C-Band (1000), Ki (150), and I-Band (2000). At the bottom, there are five buttons: a home icon, a play button, two empty buttons, and a save icon.

### Min Flow

This is the target flow rate desired from the applicator when a 0 VDC signal is received at the analog flow rate input. It is expressed in ml's/min (cc's/min). This parameter is ignored if the gun mode is manual or inject (i.e. RansPulse units).

### Pot Life

This is the amount of time it takes for the plural component material to "setup". The system keeps track of the oldest material in the fluid line (which basically is the material in the applicator) and generates a pot life alarm when the mixed material in the applicator has been mixed for this amount of time. It is expressed in seconds.

### Notes

This box allows the user to enter some simple text notes that they would like displayed with the job data. (Possibly, descriptions of the material or parts that should be used with these job parameters, etc.) Editing of this text requires connection of a keyboard inside the controller. Contact your Ransburg Representative if you need more information to use this feature.

### Ratio (Parts)

This parameter controls the mix ratio of the material for plural component materials. It must be specified in parts and on all channels configured to the gun. For example, if it was desired that the mixed ratio of material was to be 50% resin (channel A), 30% catalyst (channel B), and 20% solvent (channel C), the ratio for channel A should be programmed at 5, the ratio for channel B should be programmed at 3, and the ratio for channel C should be programmed at 2. Alternately they could also be programmed at 2.50:1.50:1.00 and achieve the same ratio. Note that the last parameter does not need to be 1.

## Job Parameters Screen (continued)

The screenshot shows the 'JOB Settings' window. On the left, 'Job 1' is selected. The 'Job' section includes: Channels (3), Flow Rate (220), Max Flow (0), Min Flow (0), and Pot Life (360). Below this is a 'Notes' field. The 'Channel' section (Channel A) includes: Ratio (Parts) (2), MVR High (100), Pulses/Liter (8000), MVR Low (15), and Valve (1). The 'Advanced' section includes: Kp (2000), C-Band (1000), Ki (150), and I-Band (2000). At the bottom are icons for Home, Play, Stop, and Save.

### Pulses/Liter

Although this value can be programmed on this screen, it is recommended that it be setup using the calibration routine. It is the number of pulses per liter that the flow meter sends out for the material being flowed. This may vary significantly from material to material based on viscosity, shear, flow rate, etc.

### Valve

This allows the user to program the color valve that will be opened when this job number is loaded. The master channel can control up to 10 color valves and the slave channel can control up to 3 color valves. **NOTE: When running in 1k mode, ensure that NO slave channel valve is programmed to be opened.**

### MVR High

This is the maximum pressure (in psi) that is allowed by the software to be sent to the flow control valve (which in most cases will be an MVR valve). This value is used during flushing, loading, and for the master channel of a manually configured gun. This also limits the maximum pressure that is allowed to be sent to the flow control device while running (PID control) so users are warned that specifying too low of a value here can limit the maximum possible flow rate and possibly response time of the PID control loop. It is expressed in psi. (This parameter can also be temporarily changed on the Channel Parameter Screen.) [This parameter is ignored if the mode is inject.]

### MVR Low

This is the pressure (in psi) sent to the flow control valve when the gun is in run mode with the applicator not triggered. It acts as an 'offset' to hold the flow control valve just below the cracking pressure of the valve so that when the applicator is triggered, a minimal amount of time is lost opening the valve for flow. If this parameter is programmed too high (above the cracking pressure of the valve), undesirable pressures will develop between the flow control valve and the applicator during trigger off times, causing a 'blooming effect' when the applicator triggers, until the higher pressure bleeds off. (This parameter can also be temporarily changed on the Channel Parameter Screen.) [This parameter is ignored if the mode is inject.]



## Job Parameters Screen (continued)

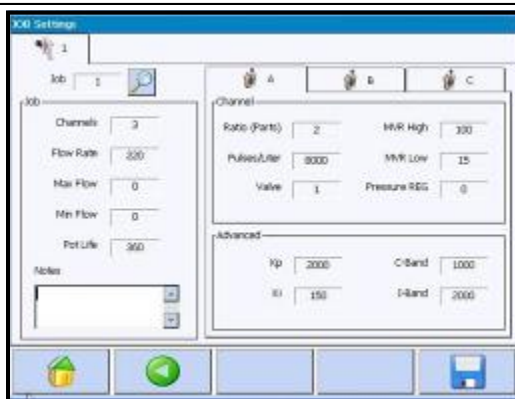

### Pressure REG

This is a simple analog output that can (optionally) be used to control a pilot operated fluid regulator on the inlet of the flow control valves. Additional E to P transducers will be required to convert this 0 to 10 VDC signal to a 0 to 100 psi signal to control these fluid regulators. (Thicker materials or higher flow rates often require a higher inlet pressure to the flow control valves.) (This parameter can also be temporarily changed on the Channel Parameter Screen.) [This parameter is ignored if the mode is inject.]

### Kp

This is the Proportional Gain parameter for the PID loop. It controls how fast the PID loop opens the flow control valve when flow is initially requested. A value too small here will cause an unnecessary delay in flow on the initial trigger on of the applicator or a slow ramp up of flow. Too large of a value here will cause the flow to oscillate. The default value of 2000 works well in most cases.

### Ki

This is the Integral Gain parameter for the PID loop. It controls how fast the PID loop pulls the actual flow back to the target flow after the proportional portion of the PID loop has the actual flow approaching the target. (This parameter can also be temporarily changed on the Channel Parameter Screen.) A default value of 150 works well in most cases.

### C-Band

This is the control band for the PID control loop. In general, this setting should never need to be changed unless the flowmeter has been changed to a flowmeter with a significantly different calibration value. This parameter keeps the system steady while maintaining a constant flow rate. Too large a value can keep the system from getting to the target flow rate while too small a value may cause the flow rate to oscillate. (This parameter can also be temporarily changed on the Channel Parameter Screen.) A default value of 1000 works well in most cases.

### I-Band

This is the integrator band for the PID control loop. In general, this setting should never need to be changed unless the flowmeter has been changed to a flow meter with a significantly different calibration value. This parameter controls how responsive the system is when the desired flow rate changes. Too large a value will cause the system to overshoot the target flow while too small a value may prevent the system from reaching the target flow rate or possibly even cause the flow rate to oscillate. (This parameter can also be temporarily changed on the Channel Parameter Screen.) A default value of 2000 works well in most cases.

## Alarms Screen



The second button on the main screen takes you to the reports page. The first screen you enter is the Alarms page.

The icons across the bottom of the screen, starting from the left are:

- Return to Home Screen
- Go back one screen
- Return to Alarms Screen (used if you are on the Totals or Information Screens)
- Flow Totals
- Information Screen (Software versions, etc.)

The last 100 alarms are listed with the latest one always appearing at the top of the screen. (Older alarms automatically scroll off of the bottom of the screen. Simply touch the scroll bar on the right side of the screen to scroll down.) To clear the screen, simply touch the eraser icon in the upper right corner of the screen. Note: Faults must be reset on the Emulator Screen.

## Reports Screen

The screenshot shows a 'REPORTS' screen with two tabs labeled '1' and '2'. Below the tabs, there is a 'Totals' section with a 'Job' dropdown set to '1' and a magnifying glass icon. The main data area is divided into two sections: 'Job Totals' and 'Clean Totals'. Each section has a table with columns for 'Channel', 'Daily Total', and 'YTD Total'. To the right of each table are buttons for 'Clear Job Daily' and 'Clear Job YTD'. A 'Clear ALL Daily Totals' button is positioned to the right of the Job Totals table, and a 'Clear ALL YTD Totals' button is to the right of the Clean Totals table. At the bottom of the screen is a navigation bar with five icons: a house, a play button, a stop button, a bar chart, and an information icon.

Job Totals		
Channel	Daily Total	YTD Total
A	28.750	28.750
B	11.125	11.125
C	0.000	0.000
Total	39.875	39.875

Clean Totals		
Channel	Daily Total	YTD Total
A	0.000	0.000
B	0.000	0.000
C	0.000	0.000
Total	0.000	0.000

The fourth button on the Reports Screen is for examining and resetting flow totalization data.

Select the job you are interested in retrieving data for and touch the examine button (magnifying glass).

Information is stored separately for all three channels. There are two independent values stored for each channel, Daily and Year to Date (YTD). These values are not tied to the clock in any way, they are simply two values that both increment when material is flowing but can be reset independently. They can be used as shift totals, totals for production runs of one single part, daily totals, weekly, monthly, etc. These six values are stored independently for all 99 jobs.

The clean totals (displayed in the bottom half of the screen) are the totals that are incremented whenever the channel is flushing. These are grand totals for all jobs; they are not stored independently for each job number.

# Information Screen



This screen indicates the current version of software installed on the unit. The top number indicates the control software version and the bottom number indicates the version of the user-interface software. These two numbers should be recorded and provided to Ransburg personnel when requesting technical support.

## Color Change Sequencer Screen

The screenshot displays the 'Color Change Sequence' interface. At the top, there are two tabs labeled '1' and '2'. Below the tabs, the 'Flush Sequence Time' is 15.000 sec and the 'Load Sequence Time' is 8.000 sec. The 'FLUSH SEQUENCE' section contains four steps:

- 1 : Resin Push: Solvent (checked), Air (unchecked), Time 5.000 sec
- 2 : Catalyst: (Solvent Only), Time 2.000 sec
- 3 : Resin Chop: Solvent 0.250 sec, Air 0.250 sec, Time 5.000 sec
- 4 : Resin Push: Solvent (checked), Air (unchecked), Time 3.000 sec

The 'LOAD SEQUENCE' section contains three steps:

- 1 : Load to Flowmeter: Resin (checked), Catalyst (checked), Channel (unchecked), Time 3.000 sec
- 2 : High Flow: Flow Rate 375 ml/min, Time 3.000 sec
- 3 : Low Flow: Flow Rate 200 ml/min, Use Analog (unchecked), Time 2.000 sec

At the bottom, there are five icons: a house (Home), a play button (Start), a circular arrow (Refresh/Reset), an empty box, and a floppy disk (Save).

The middle button on the bottom of the Main Screen opens the Color Change Sequencer Screen.

The icons across the bottom of the screen, starting from the left are:

- Return to Home Screen
- Go back one screen
- Toggle between time & volume control of sequences
- Not used
- Save Flush and Load Parameters to flash memory

The top half of this screen allows the user to program the *Flush Sequence*. There are four possible steps in the flush sequence. If the time (or volume) is programmed to be zero (0) for any step, that step is skipped.

Keep in mind that if flushing is done by volume, volumes will not be accurate if air chop cycles are used.

## Color Change Sequencer Screen (continued)

The screenshot displays the 'Color Change Sequencer' interface. At the top, there are two tabs labeled '1' and '2'. Below the tabs, the 'Flush Sequence Time' is 15.000 sec and the 'Load Sequence Time' is 8.000 sec. The 'FLUSH SEQUENCE' section contains four steps:

- 1 : Resin Push: Solvent (checked), Air (unchecked), Time 5.000 sec
- 2 : Catalyst: (Solvent Only), Time 2.000 sec
- 3 : Resin Chop: Solvent 0.250 sec, Air 0.250 sec, Time 5.000 sec
- 4 : Resin Push: Solvent (checked), Air (unchecked), Time 3.000 sec

The 'LOAD SEQUENCE' section contains three steps:

- 1 : Load to Flowmeter: Resin (checked), Catalyst (checked), Channel (unchecked), Time 3.000 sec
- 2 : High Flow: Flow Rate 375 ml/min, Time 3.000 sec
- 3 : Low Flow: Flow Rate 200 ml/min, Use Analog (unchecked), Time 2.000 sec

At the bottom, there are five icons: a house, a play button, a stop button, a blank space, and a floppy disk.

**Step 1:** Allows the user to push the material currently in the fluid line with either solvent or air for a specified time period or for a specified volume. One or the other (solvent or air) must be selected. If solvent is selected, the following valves are opened:

- Resin MVR Valve
- Resin MVR Enable Valve
- Resin Solvent Valve
- Dump Valve

If air is selected to be used to push the paint in the initial step, the following valves are opened:

- Resin MVR Valve
- Resin MVR Enable Valve
- Resin Air Valve
- Dump Valve

## Color Change Sequencer Screen (continued)

**Step 2:** Allows the user to push out the catalyst line with solvent, if necessary. If this step is set for 0, it is skipped. If this step is used, the following valves are opened:

- Catalyst MVR Valve
- Catalyst MVR Enable Valve
- Catalyst Solvent Valve
- Dump Valve

**Step 3:** The resin solvent and resin air valves are cycled to cause a scrubbing action inside of the fluid line. The user can specify how long each of the two valves is open in each cycle as well as how long they continue the cycling process. During this step, the following valves are opened:

- Resin MVR Valve
- Resin MVR Enable Valve
- Resin Solvent Valve (pulsing)
- Resin Air Valve (pulsing)
- Dump Valve

## Color Change Sequencer Screen (continued)

**Color Change Sequence**

1 2

Flush Sequence Time: 15.000 sec Load Sequence Time: 8.000 sec

**FLUSH SEQUENCE**

1 : Resin Push 2 : Catalyst 3 : Resin Chop 4 : Resin Push

Solvent  Air  (Solvent Only) Solvent 0.250 sec Air 0.250 sec Solvent  Air

Time 5.000 sec Time 2.000 sec Time 5.000 sec Time 3.000 sec

**LOAD SEQUENCE**

1 : Load to Flowmeter 2 : High Flow 3 : Low Flow

Resin  Catalyst  Channel  Flow Rate 375 ml/min Flow Rate 200 ml/min Use Analog

Time 3.000 sec Time 3.000 sec Time 2.000 sec

**Step 4:** Allows the user to push out the flushing materials left in the fluid lines with either air or solvent. (For plural component materials, it is often recommended to leave unpressurized solvent in the lines when the system is not in use to soften any material that may have “skinned” the inside of the fluid lines. That material should be flushed out at the start of the next paint cycle.) The valves that are opened during this step are:

- Resin MVR Valve
- MVR Enable Valve
- Resin Solvent (or Resin Air) Valve
- Trigger Valve

**Note:** This final step flushes the applicator itself as the dump valve is closed and the trigger valve is opened.



## Color Change Sequencer Screen (continued)

The screenshot displays the 'Color Change Sequence' interface. At the top, there are two tabs labeled '1' and '2'. Below the tabs, the 'Flush Sequence Time' is set to 15.000 sec and the 'Load Sequence Time' is 8.000 sec. The 'FLUSH SEQUENCE' section contains four steps:

- 1 : Resin Push:** Solvent (checked), Air (unchecked), Time: 5.000 sec.
- 2 : Catalyst:** (Solvent Only), Time: 2.000 sec.
- 3 : Resin Chop:** Solvent (0.250 sec), Air (0.250 sec), Time: 5.000 sec.
- 4 : Resin Push:** Solvent (checked), Air (unchecked), Time: 3.000 sec.

The 'LOAD SEQUENCE' section contains three steps:

- 1 : Load to Flowmeter:** Resin (checked), Catalyst (checked), Channel (unchecked), Time: 3.000 sec.
- 2 : High Flow:** Flow Rate: 375 ml/min, Time: 3.000 sec.
- 3 : Low Flow:** Flow Rate: 200 ml/min, Use Analog (unchecked), Time: 2.000 sec.

At the bottom, there are five icons: a house, a play button, a stop button, a blank space, and a floppy disk.

The bottom half of the Color Change Sequencer Screen allows the user to control the **Load Sequence**. Once again, if any of the times (or volume) are set to zero, the step is skipped.

**Step 1:** The user can specify which valve or valves should be opened to allow material to flow from the color valve stack to the flow meter and for how long. The valves that are opened during this step are:

- Resin MVR and/or Catalyst MVR and/or Component C MVR Valves
- Resin CCV and/or Catalyst CCV Valve (note that which of the resin and catalyst CCV valves opened is based on information provided on the Configure Job Screen)
- Resin and Catalyst MVR Enable Valves
- Dump Valve

**Step 2:** The controller switches to run mode and starts controlling the flow of the material or materials. This can be done at a fairly high flow rate since the dump valve is still opened. Material should be run in this step until mixed material is approaching the dump valve and then this step should end. (It is not advisable to send mixed material through the dump valve as the next spray cycle may exceed the pot-life time of the material and the material could set up in the dump valve.) The valves that are on during this step are:

- All MVR Valves are PIDding (except the master channel of manual or inject mode guns)
- Resin and Catalyst MVR Enable Valves
- Resin and Catalyst CCV Valves
- Dump Valve

## Color Change Sequencer Screen (continued)

The screenshot displays the 'Color Change Sequence' interface. At the top, there are two tabs labeled '1' and '2'. Below the tabs, the 'Flush Sequence Time' is 15.000 sec and the 'Load Sequence Time' is 8.000 sec. The 'FLUSH SEQUENCE' section contains four steps:

- 1 : Resin Push: Solvent (checked), Air (unchecked), Time 5.000 sec.
- 2 : Catalyst: (Solvent Only), Time 2.000 sec.
- 3 : Resin Chop: Solvent 0.250 sec, Air 0.250 sec, Time 5.000 sec.
- 4 : Resin Push: Solvent (checked), Air (unchecked), Time 3.000 sec.

The 'LOAD SEQUENCE' section contains three steps:

- 1 : Load to Flowmeter: Resin (checked), Catalyst (checked), Channel (unchecked), Time 3.000 sec.
- 2 : High Flow: Flow Rate 375 ml/min, Time 3.000 sec.
- 3 : Low Flow: Flow Rate 200 ml/min, Use Analog (unchecked), Time 2.000 sec.

At the bottom, there are five icons: a house, a play button, a stop button, a blank space, and a floppy disk.

**Step 3:** The dump valve closes and the trigger valve opens. Flow rate is normally reduced in this step since the applicator typically cannot handle as high a flow as the dump valve. This step is intended to prepare the applicator for the first trigger on a part. This flow rate can be programmed or if the Use Analog radio button is selected, the unit will use the signal from the analog input to determine the target flow rate required in this step. (Refer to the section explaining the Job Parameters to program the Min Flow and Max Flow parameters for this analog feature to work.)

## Tools Screen

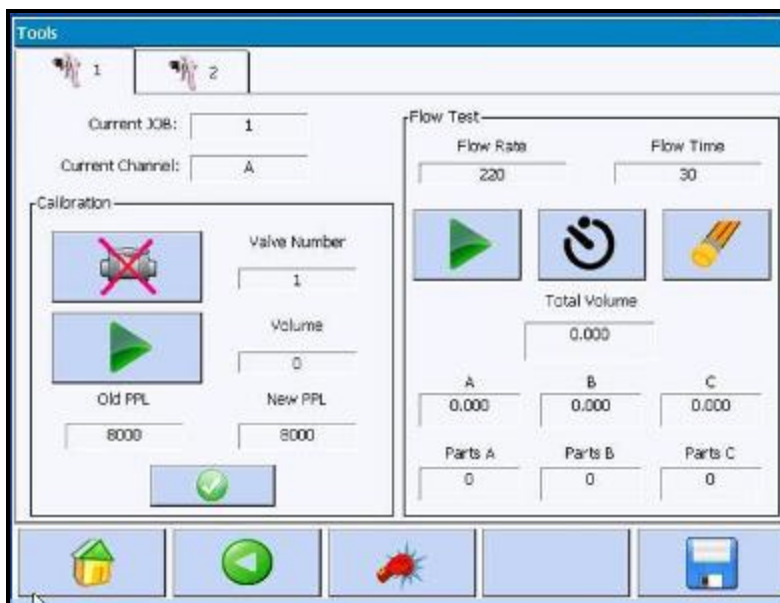

The fourth button from the left on the Main Screen selects the Tools Screen. From here, users can perform functions such as calibrate the flow meters, do flow tests, and test all digital and analog inputs and outputs.

**Note that this screen cannot be opened if the gun is in the run state!**

The icons across the bottom of the screen, starting from the left are:

- Return to Home Screen
- Go back one screen
- Force I/O Screens
- Not used
- Save Calibration Parameters to flash memory

### Calibration (Left half of Tools Screen)

Four items must be selected prior to calibrating: The Gun Number (tab at the top of the screen), the Job Number (Current JOB) that you want the new calibration values saved to, the channel (Current Channel) which can be A, B, or C, and the Valve Number (this is which color valve) that should be opened during the calibration process. To change the values of Job, Channel, and Valve, simply touch the white box where the value appears that you wish to change and a keypad will popup, allowing you to change its value.

Note: There are three buttons inside the calibration section of the tools screen. The top button has the image of a valve with a red cross through it. This indicates that presently the valves are closed. When you touch this button, three things will happen: The color valve that you selected will open, the MVR enable signal (solenoid valve) for the channel you selected will open, and the MVR valve will go to its MVR High pressure. (The 'X' in front of the valve will disappear, indicating the valves are open.) This allows you to flow material from the color valve down through the MVR valve, flow meter, calibration valve, etc. and get any air out of the fluid lines prior to calibrating. This button can remain on during the entire calibration process if you have a downstream valve to control the flow of material during calibration (such as a calibration ball valve or trigger valve at the applicator, etc.)

## Tools Screen (continued)

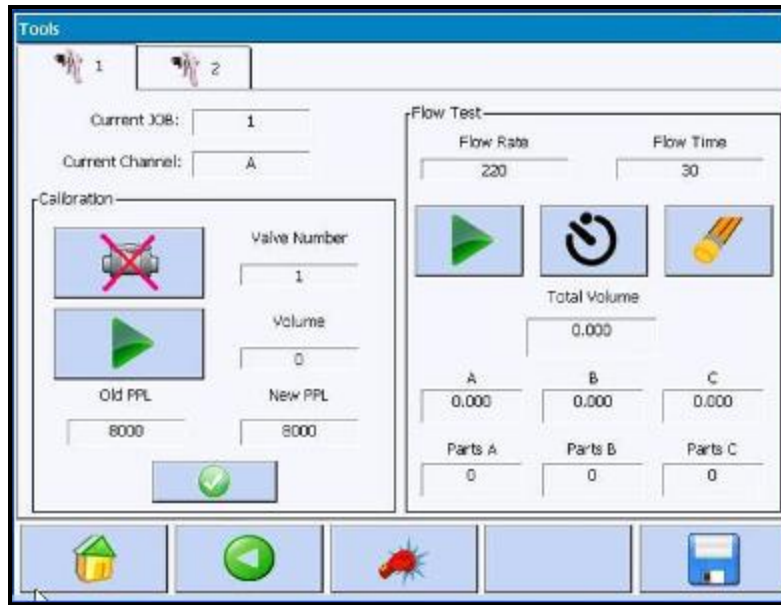

The second button inside of the calibration section of the screen is a large green arrow. When this button is pushed, the software will begin counting pulses from the flowmeter. (This button changes to a red stop sign when pushed.) To calibrate, simply push this green arrow button and then open your calibration valve (or trigger valve) and flow an adequate amount of material into a graduated cylinder. Close the calibration valve (or trigger valve) and push the red stop sign button. Next, touch the white box under the text Volume and a keypad will pop up. Enter the volume (in milliliters) that was collected in the graduated cylinder and push enter (ENT). The software will automatically calculate a new calibration value for the flow meter (in pulses per liter) and display it in the lower right box under New PPL. If this value seems reasonable, touch the small box at the bottom of the screen with the check mark in it. This will copy the most recently calculated value over to the box at the left labeled OLD PPL. (This is the value that the software uses to calculate the volume of material as it is counting pulses.)

You should repeat the calibration process until you get at least three consecutive values that are within 5% of each other. Touch the top (open valve) button to close all valves on the channel and color you are calibrating once you are satisfied with the calibration value. Once this has been done, touch the Save to flash memory button in the lower right hand corner of the screen to save the new PPL value to the selected Job. Note that leaving this screen without performing this save function will lose the calibration data you just determined.

This calibration process must be completed for all channels configured to the gun. Also note that these calibration values must be determined for all materials that are to be used. It is recommended that one job number be used for each material as different materials affect the flow meters in different ways and will result in different calibration values. Make sure to save values to flash memory after each calibration process has been completed, using the save button in the lower right corner of the screen. Note: If the save button is black or greyed out, the gun may be in the run or faulted state. Values can't be saved while in these states. Return to the Emulator Screen and turn the gun off or reset the fault.

## Tools Screen (continued)

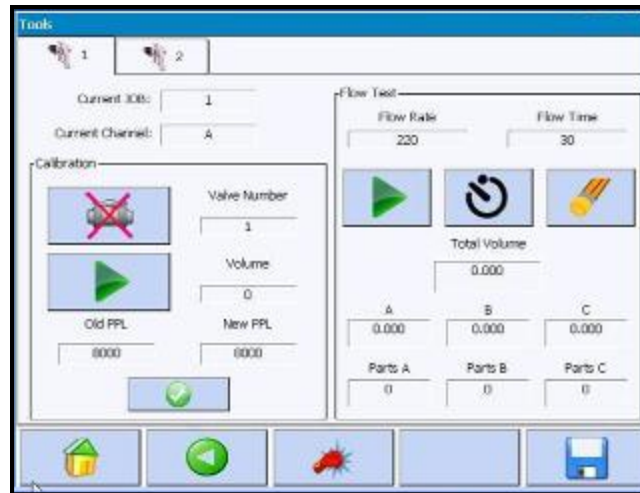

### **Flow Test (Right half of Tools Screen)**

Once calibration has been completed, it is a good idea to do some flow tests to insure that the system is flowing at the proper flow rates and giving the proper ratios. The Flow Test screen can be used to easily accomplish this.

Prior to doing a flow test, go back to the emulator screen and perform a load sequence for the material (Job) that you wish to perform the flow test on. Take the gun out of run mode by touching the red stop sign button prior to leaving the emulator screen.

Return to the Tools screen and, once again, begin by selecting the tab for the gun you wish to perform the flow test on at the top of the screen. Next, touch the white box below the Flow Rate text and enter the target flow rate that you wish to come out of the applicator (total of all channels) during the flow test. Next, program how long (in seconds) you wish the flow test to run for under Flow Time. If there are values displayed under Total Volume or the A, B, or C channels, they can be reset to zero by touching the eraser button on the right side of the screen.

At this point, the gun can be placed in "Run Mode" by touching the green arrow button on the left side of the Flow Test screen. To start the flow test, simply touch the middle "Timer Start" button. Flow will start immediately and a signal will be sent from the trigger solenoid valve. Make sure to open the applicator if it is not being controlled by the RansFlow's trigger valve or a flow too low fault will occur. The unit will continue to flow for the amount of time programmed, at which point the trigger valve will be closed and flow will be stopped. During the flow process, the Total Volume and the volumes under channels A, B, and C, (or whatever channels are configured to the gun) will be incremented based on pulses received from the appropriate flowmeters. If the materials are collected independently of each other from the calibration ports, those values can be compared to the volumes that the software calculated as having been dispensed. If any of the volumes are outside of acceptable limits, the flow meter for that channel should be recalibrated.

An additional feature of this screen allows you to have the software calculate the actual ratio of the material(s) that were dispensed. Simply touch the white box below the heading Parts A and enter what the target ratio for the master channel was. The software will then automatically calculate the other component or other components ratios for easy comparison to the target. Once again, if any of the component's ratios are outside of acceptable limits, recalibration of the flow meter or flowmeters is recommended.

## Force I/O Screen

Selecting the red boxing glove from the first Tools Screen takes you to the Force I/O Screen shown below.

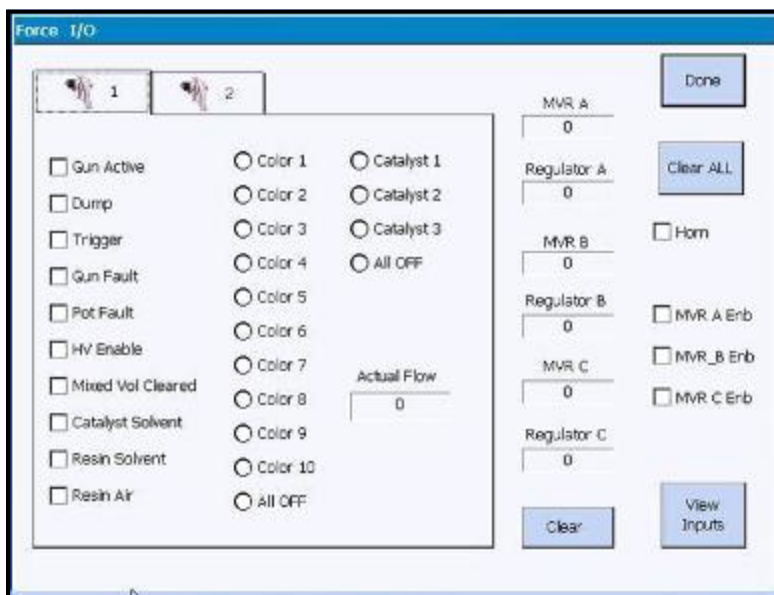

This screen allows the user to force any of the digital (discrete) or analog outputs of the RansFlow System. Also from this screen, the user can select the View Inputs Screen.

The first column allows you to force the digital status outputs. Simply touch the square next to the signal you wish to force on and a checkmark will appear in the box indicating that the signal is forced on. To remove the force simply touch the box a second time or touch the Clear ALL button in the top right of the screen.

The second column allows you to force any of the color valve solenoids on. Only one can be forced on at a time (to prevent materials backing up from one supply line to another if they don't have matching pressures). Simply touch the radio button next to the color valve you wish to turn on. To turn it off, touch the All OFF radio button at the bottom of the second column or the Clear ALL button.

The third column allows you to force any of the catalyst valve solenoids on. Only one can be forced at a time (to prevent materials backing up from one supply line to another if they don't have matching pressures). Simply touch the radio button next to the catalyst valve you wish to turn on. To turn it off, select another valve to turn on or touch the All OFF radio button in the third column or the Clear ALL button.

Also in the third column is a box marked Actual Flow. This drives an analog output that is proportional to the flow rate passing through the applicator. If you touch the box below the Actual Flow text, a keypad will appear allowing you to key in a voltage to send to this analog output. Key in a value of 0 to reset. (Forcing this value has no effect on RansPulse systems.)

## Force I/O Screen (continued)

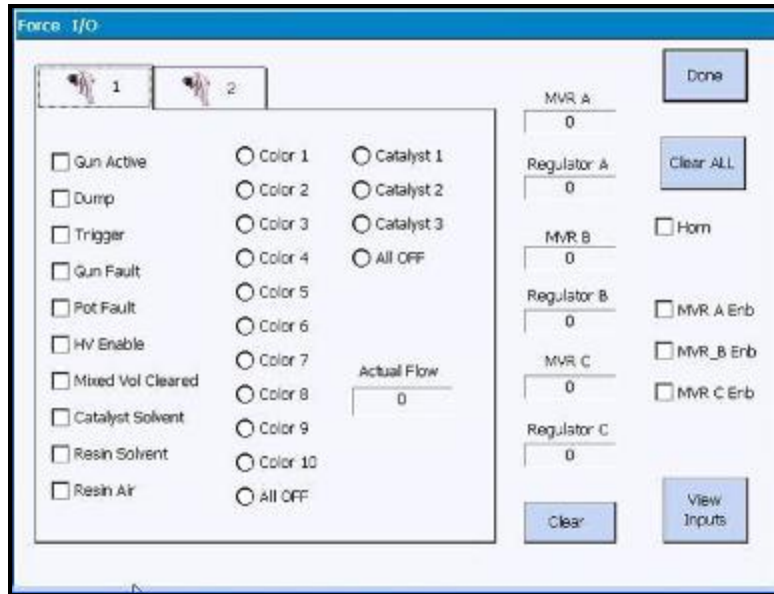

The fourth column allows you to force the analog outputs that drive the transducers that in turn drive the MVR valves (MVR A, MVR B, MVR C). There are three additional analog outputs (Regulator A, Regulator B, and Regulator C) that can be forced. (These outputs allow the user to optionally connect a pilot operated fluid regulator to the input of the MVR valve and specify different inlet pressures for different materials.) Simply touch the box below the output to be forced and key in the voltage desired out of the analog output. Key in a value of 0 to reset the output. (All valves in the 3rd column are ignored in RansPulse units.)

The fifth column allows the user to force the horn on and the MVR Enable signals (solenoids). Simply touch the box next to the text that you wish to force and check mark will appear when the output is turned on. Touch the box a second time to turn the output off or touch the Clear ALL button.

In the bottom right corner of this screen is a button labeled View Inputs. Select this option if you wish to monitor the status of any of the digital or analog inputs.

# View Inputs Screen

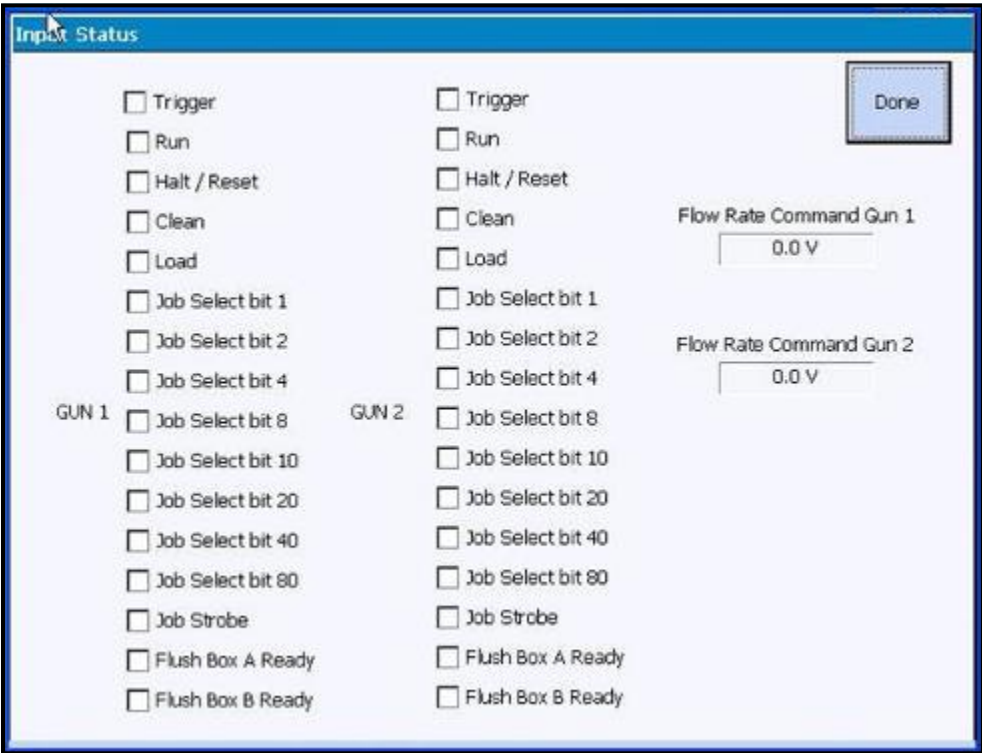

This screen displays the status of all input signals. A checkmark beside any label indicates a signal is present at that input. The two Flow Rate Command boxes indicate the input voltage on that input.



# Emulator Screen

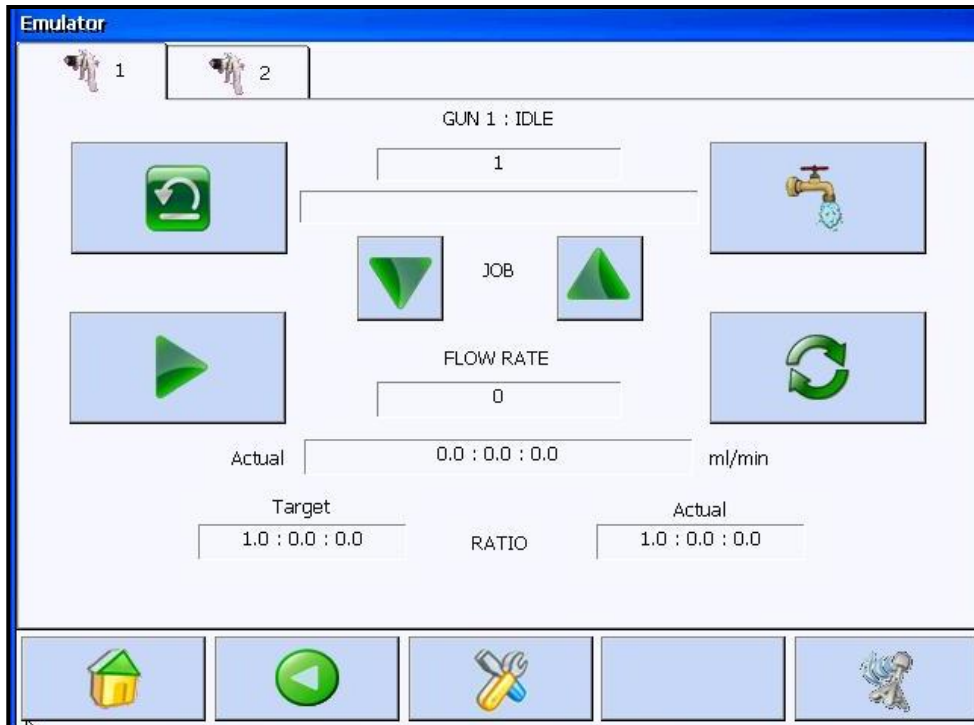

The fifth button from the left on the Main Screen selects the Emulator Screen. From here, users can perform functions such as select the job number to load, load material to the applicator, flush the applicator, put the gun in run mode, halt the gun, reset faults, and view the status of the gun, the currently running job number and the current flow rate.

The icons across the bottom of the screen, starting from the left are:

- Return to Home Screen
- Go back one screen
- Dosing Valve State →
- Not used
- Enable the Remote Operator Panel

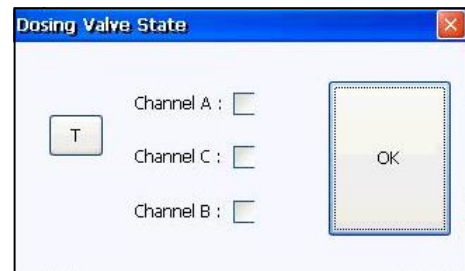

The icons in the upper area of the screen are described below:



The upper left button is the Reset/Halt button. It changes its appearance depending upon the mode the gun is in. If the gun is faulted, this button resets the fault. If the gun is running, it halts it. The gun must be in run mode to flow material.

## Emulator Screen (continued)

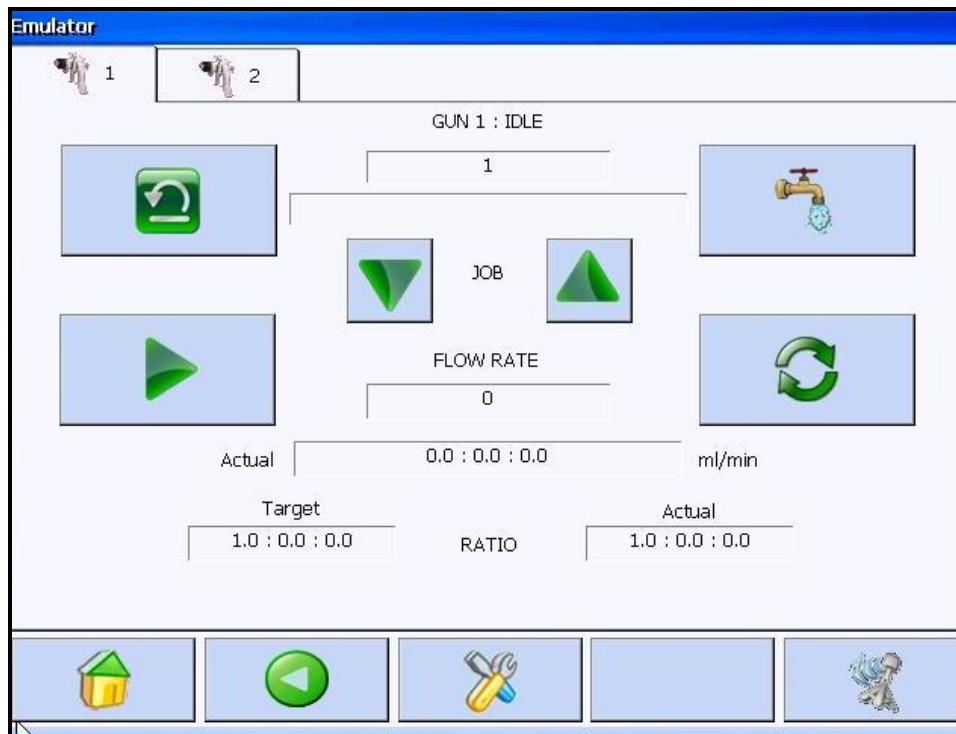

Run – this button puts a halted gun in run mode (which enables it to flow).



Flush – this button performs a flush of the applicator(s).



Load – this button performs a load sequence on the applicator. (Which in turn loads the job number specified on this screen.)



Previous/Next Job Number – these two buttons allow the user to select the next job number to load.

# Section 5: OPERATION

## Emulator / Remote Operator Panel Screen

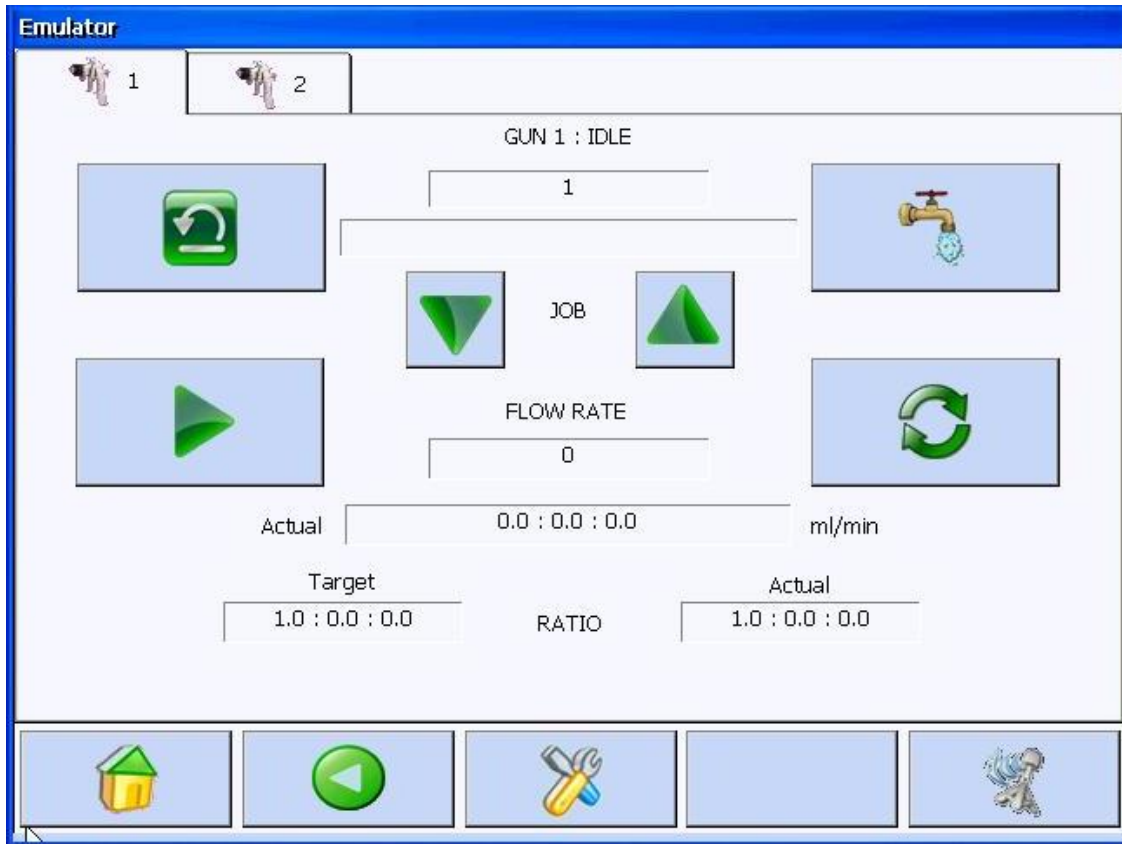

**Emulator Screen** on RansFlow Main Control Panel

All gun/applicator operation can be done from the Emulator screen or from the optional Remote Operator Panel.



Optional RansFlow **Remote Operator Panel**

# Start Spraying

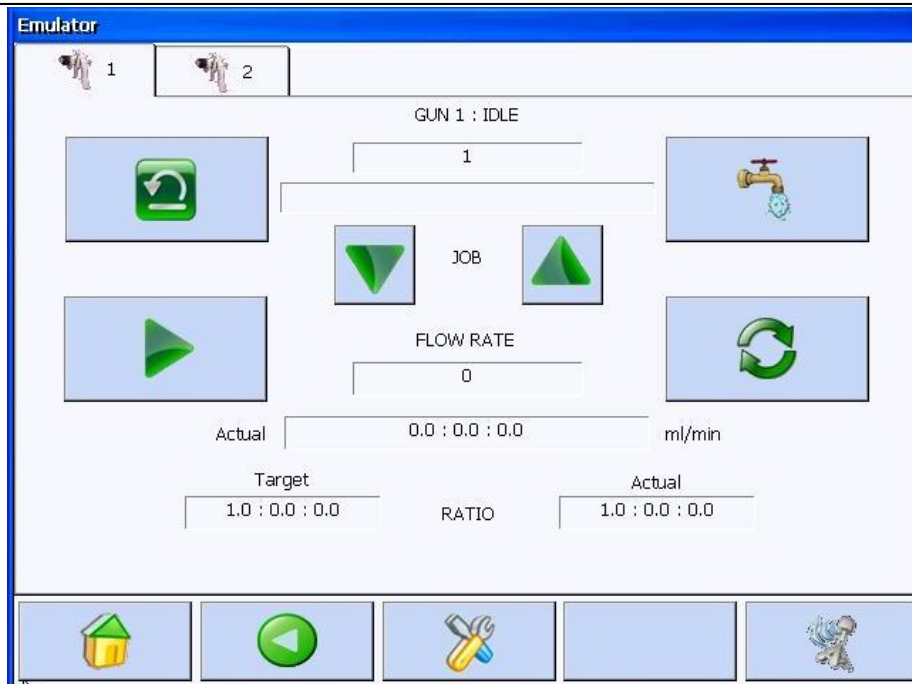

## Two steps to start spraying:

### 1. Start-up

- Turn ON AC power and let the software startup.

### 2. Loading a Job

- Go to the EMULATOR screen:



- Press the RESET / STOP button to clear any initial faults:



- Press the UP/DOWN arrows to select the job you want to use:



- RansFlow must be in the idle/halt state. Press HALT:



\*\*If unit is already in idle/halt state, this button will not be visible.

- Press LOAD:



- On the first load after power up, or if a job with a new color is selected the RansFlow will do a flush before it loads.
- When the load sequence is complete the RansFlow will be placed in RUN mode and the gun/ applicator will be ready to spray.

# Finished Spraying

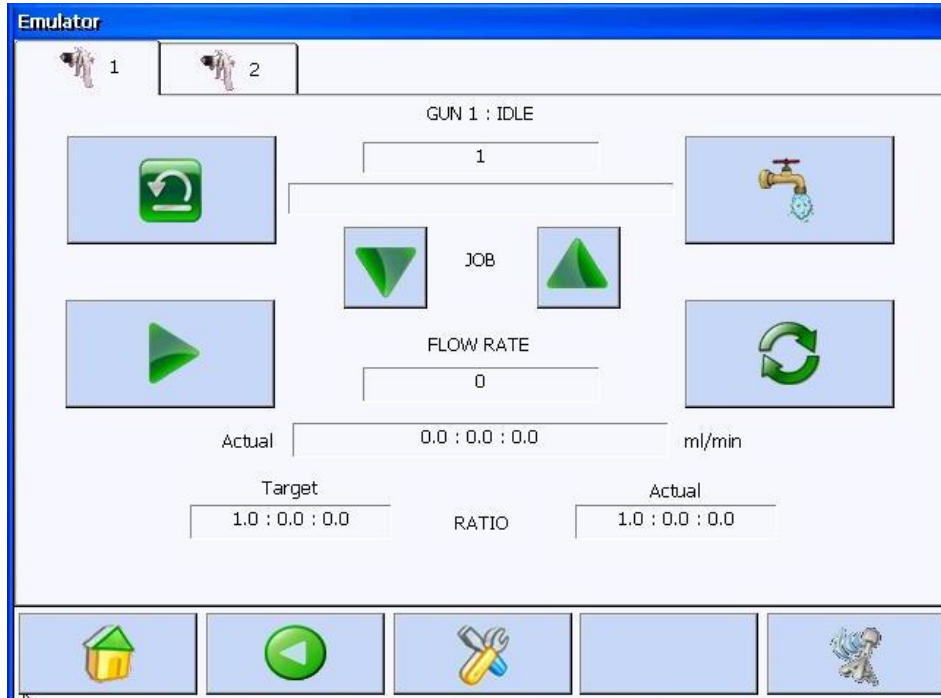

Two steps when finished spraying:

## 1. Flushing

- RansFlow must be in the idle/halt state. Press HALT:



\*\*If unit is already in idle/halt state, this button will not be visible.

- Press FLUSH:



- The RansFlow will step through the flush sequence leaving the gun clean and idle.

## 2. Recovering from a Fault

- If a fault occurs, first the unit must be RESET:



- The unit must be placed back into RUN mode:



- The fault that occurred may be viewed on the **Reports Screen**.

## Section 6: TROUBLESHOOTING

### POWER SUPPLY ISSUES

There are two DC power supplies in the main control Enclosure, one at 5 VDC and a 24 VDC, both capable of 5 amps, maximum. Neither power supply is fused. If a short in the electrical system does occur (greater than 5 amps is sensed), the power supply will shut down its output until that short is removed. It may be necessary to cycle the AC power feeding the power supplies to permit them to reset properly. The photograph below shows the terminals on the power supplies that can be used to verify output voltages with a voltmeter.



Proper OSHA Lockout/Tagout procedures must be followed prior to performing any equipment maintenance or repair.

The AC power is fed into the bottom of the supplies (L=Hot and N=Neutral). The DC power exits the top of the supplies with the positive terminals marked with a plus (+) sign and the ground terminals with a negative (-) sign. Note that both power supplies have voltage adjustment screws on them that are factory preset but can be readjusted, if necessary. If the 5 volt supply is not within 10% of 5.00 volts (4.95 to 5.05), it should be adjusted. If the 24 volt supply is not within 10% of 24 volts (21.6 to 26.4), it should also be adjusted. The larger 24 VDC power supply also has a Single/Parallel switch that should be set on the Single position.

If no voltage is detected on the output of either supply, and cycling the AC power does not restore the output, try removing the wires on the output of the supply (with the AC power off) and then power up the unit. If there is still no voltage, replace the power supply. If the voltage recovers, place an ammeter in circuit and check to see if you have exceeded the 5 amp limit of the supply. If current draw is less than 5 amps, replace the power supply. If the current draw is greater than 5 amps, look for excessive current draw in the system.

A third 24 VDC to 15 VDC converter box will also be mounted on the DIN rail with these two power supplies if the intrinsically safe remote operator panel option is installed. The 15 VDC output of this supply should also be within a  $\pm 10\%$  limitation.

## **FLOW TOO LOW OR FLOW TOO HIGH FAULTS**

These types of faults can be caused by numerous problems. We will attempt to describe most of the more common causes below. Keep in mind that, as the name implies, the controller thinks that either too little or too much material is getting to the applicator. This troubleshooting manual assumes that the system was running at one time and something has gone wrong. It is not meant as a manual for setting up a new system, however, many of the troubleshooting procedures described can be used in either case.

1. **Has your material supply pressure changed?** What was the material supply pressure when the system was running properly? Is it the same now? Do you really trust the pressure gauge you have been using for the past several years? The controller can compensate for small changes in pressure (typically 10 psi) but changes greater than this or large pressure surges (as is seen with piston pumps without surge chambers) are a definite problem. In most cases the catalyst supply pressure should be run at a minimum of 10 psi higher than the resin. If it is a high pressure system, it should be about 10% higher.
2. **Has the viscosity of the material changed?** A significant change in viscosity alters the way in which it passes through the fluid metering equipment (MVR valve, flow meter, check valves, Y-block, spiral mix tube, etc.). Typically, an increased viscosity will require more pressure to get to the same flow rate. However, in some cases (as with thixotropic materials), the viscosity will actually change as the pressure varies or as the material passes through the MVR valve and the flow meter. Note that there is a large pressure drop across the MVR and flow meters. Additionally, the material 'chopped' into small chunks as it passes through the flowmeter (and inject valves), and this can cause some materials to change their properties as they flow.
3. **Has a restriction formed somewhere in the fluid line?** This could be a kinked tube, contamination in the MVR or flowmeter, spiral mix tube blockage, or sticky check valve, "Y" block blockage, to name but a few. An easy way to verify that the system is capable of flowing at the flow rate required is to flush the applicator. Watch the flow rate during the flush sequence. If the system cannot get to the required flow rate in flush mode, the system will not be able to get there in run mode since MVR valves are wide open in flush mode. This tests all fluid lines from the material supply to the applicator. Try running the unit from the calibration ports on the fluid panel. Place containers under them, open the calibration ports, and put the unit in run mode. (If the unit is being operated in automatic mode, the trigger will have to be forced on.) If the unit operated correctly that way, the problem is further downstream.
4. **Are you seeing any flow at all?** If it is obvious that material is flowing out of the gun (or from the calibration port) but the display shows no flow at all then this indicates that the controller is not seeing any pulses coming from the flowmeter. This could be caused by the gears in the flow meter being stuck, a bad sensor on the flowmeter, a disconnected or damaged flow meter cable, a bad zener barrier, or a bad counter card. Disassemble the affected flow meter and inspect it for stuck gears. If it is obvious they are not stuck, place the shafts and gears in the top half of the flowmeter and, with the sensor on the flowmeter and cable connected, turn the gears. Watch the flow volume value on the main screen of the controller. The volume should increment with fluid flow. If it does not, than one of the problems mentioned above has occurred. Next, connect the flowmeter to a cable of another channel that is functional and monitor that channel for flow. If flow is not indicated, you may have a bad flow meter sensor. It is also possible that a fuse in the zener barrier has failed. (Note, zener barriers are optional and only used on intrinsically safe units.) Find the zener barrier that is connected to the channel you are having a problem with. (Refer to electrical diagrams in this manual.) On the side of the zener barriers there are schematics of the internal circuitry. Fuse integrity can be verified quite easily with an ohmmeter. The flow meter cable itself can also be tested with an ohmmeter.
5. If this is a RansPulse, keep in mind that the inject valves have an adjustable travel on their needle valves. It is adjusted with a thumbscrew on the top of the valve. It is possible to actually prevent the valve from opening at all if adjusted to far to one end.

If none of these are the problem, there are only three other possible problems. The first is the high speed counter card mounted on the back side of the touch screen computer may be defective. (It is the top card on the stack of 3 cards.) The second option would be a problem with the ribbon cables (or their connectors) that run from the interconnect board on the inside-top of the control Enclosure or the ribbon cables that run from the high speed counter card to the optical isolator board. Another possible problem would be the Optical Isolator Board B (P/N: A12207). The optical isolator board has some signal conditioning circuitry on it that reduce the 24 volt flow meter pulses to 5 volt pulses (used by the counter card) and clean up any noise.

6. **Another possible cause of these type of faults would be if the transducer that controls the MVR valve would fail.** Verification that the transducer for the affected channel is functioning properly is as follows... If there is not already one there, place a pressure gauge in the pilot line between the transducer and the MVR valve. Go to the Force I/O screen on the touch-screen of the controller. Set MVR pressure for the channel you are troubleshooting at various pressures between 0 psi and 100 psi (we suggest every 5 to 10 psi to verify linearity of the transducer). Monitor the actual pressure with the gauge, again insuring only a 10% variance. If the transducer does not perform as described, replace it. NOTE: Make sure there is not a leak in the tubing leading to the MVR valve or in the MVR valve itself! The transducers are very low volume devices and are designed to only feed dead-headed devices. (If this is a RansPulse unit, verify that the solenoid valves that drive the injector valves are working properly, as well as the injector valves, themselves.)
7. **If you notice in test #5, that the transducer is not responding as expected, it may be the signal coming from the analog output board in the controller is at fault.** First, make sure you have 24 volts ( $\pm 10\%$ ) feeding the transducers (refer to electrical diagrams in this manual and the picture below). There are 3 wires connected to the terminal block in the upper left of the transducer. The far left terminal is the ground terminal (wire #2101), the terminal second from left is the +24 VDC terminal (wire #2011), and the third from left terminal is the command input. The wire numbers for the command signals vary from channel to channel. (RansPulse units are not equipped with transducers.)



8. **Follow the procedure above (in test #5) to send various voltages to the transducer from the analog output card.** There is a 1:10 ratio between the voltage sent to the transducer and the pressure the transducer should produce. That is, if MVR output is set to 1.0 volt, a 1 volt signal should be output by the analog output board to the transducer and the transducer should respond with 10 psi on its pneumatic output. Likewise, 2 volts = 20 psi, 3 volts = 30 psi, etc. If you suspect a faulty analog output card it should be replaced.



## OUT OF TOLERANCE FAULTS

Out of tolerance faults are generated in the following way... Every time a preprogrammed volume of mixed material passes through the mix tube (specified by the Tolerance Volume Parameter), the controller determines the amount of resin and catalyst that flowed during that time interval. The software then calculates the actual ratio that flowed based on those two volumes and it checks to see if the actual ratio is within the Flow Tolerance specification on the Gun Parameters Screen.

The reason this fault is generated even though there were no flow too high or flow too low faults is probably best explained with an example: If, for instance, we have a 2k material that is supposed to be mixed at a 3:1 ratio and spray out of the applicator at 400 ml's/min. We have the Flow Tolerance set to 10% and the Tolerance Volume set to 200 ml's. The software sees this to mean it should flow 300 ml's/min of resin and at the same time 100 ml's/min of catalyst, and that is what it attempts to do. As long as the resin flow rate remains between 270 ml's/min and 330 ml's/min ( $\pm 10\%$ ), and the catalyst flow rate stays between 90 ml's/min and 110 ml's/min ( $\pm 10\%$ ), you will not receive a flow too low or flow too high faults. If, however, the resin is flowing at 280 ml's/min and the catalyst is flowing at 107 ml's/min (both within the 10% flow rate tolerance), you will get an Out of Tolerance Fault. The reason for this is the way the 2k software generates out of tolerance faults. As was mentioned earlier, after each volume of mixed material specified by Tolerance Volume passes through the mix tube, the 2k software looks to see how much of it was resin and how much of it was catalyst. The software then determines the actual ratio (based on volume rather than flow rate). If that ratio is above or below the preset ratio by more than the Flow Tolerance specified in the parameters, it generates an out of tolerance fault. In our example above, the volume of resin would have been 143.6 ml's and the volume of catalyst would have been 56.4 ml's (out of the total of 200 ml's). Therefore, the ratio of resin to catalyst would have been 2.545:1 which, on the catalyst side, is more than 10% high. The unit will, therefore fault with an out of tolerance fault on the catalyst channel ( $25\% + 2.5\% = 27.5\%$ ). Keep in mind that ratio is calculated based on total volume; therefore the catalyst ratio above is calculated by:

$$\frac{56.4 \text{ ml}}{200 \text{ ml}} \times 100 = 28.2\%$$

Most of the time when this fault is seen, the cause is the material supply pressures. Obviously, if you are not getting flow too low or flow too high faults, the flow rates are getting within the tolerance band of the target. Over an extended period of time, however, the volumes used may not be within that same tolerance band. Observe the actual ratio on the main screen of the controller. (Note that the ratio displayed is an average over a period of time. In order to get instantaneous ratio information, touch the Volume box in the lower right of the main screen and reset its value.) If the actual ratio of the catalyst is below target, adjust the supply pressure to the catalyst MVR valve up 5 psi or so, or adjust the resin supply pressure down by 5 psi or so and try to run again. Keep adjusting these pressures until the actual ratio locks in on the target. Keep in mind that higher is not always better. Often times it works better to lower the pressure of the opposite channel, rather than raise a channel that is running low in ratio.

## **REVERSE FLOW LIMITS**

As the name indicates, the software believes that material has backed up through one of the flow meters. This can be caused by any one of the following conditions:

1. **If any of the check valves on the fluid panel has failed in the open condition and the opposite fluid is at a higher pressure, fluid can actually back up into another line.** If this occurs, the system must be flushed immediately and the faulty check valve replaced.
2. **This is sometimes seen after a gun has been flushed and left unused for a period of time, such as at the end of the day or end of the shift.** This may be the result of pressure trapped in the line between the MVR valve and the applicator. This pressure eventually will back up through the flow meter and out the weep port on the MVR valve. To prevent this, make sure the applicator stays triggered for a few seconds after the controller is taken out of clean mode to relieve this pressure.
3. **When electrostatic sprayguns are used, it is not uncommon to see a very large value (in 100,000 of ml's range) displayed for reverse flow.** This is caused when electrostatic 'noise' is generated at the flowmeter. That is, if the flowmeter is not properly grounded and high voltage feeds back through the paint line from the applicator, noise is generated in the flowmeter cable. This noise is read by the software controller as reverse flow. Make sure the flowmeter is adequately grounded. This must be the same ground that is used in the controller.
4. The software determines reverse flow by use of quadrature signals fed back from the flowmeters. There are 2 sensors on the standard flowmeter and the order in which the square waves are sent back to the controller determine if flow is forward or reverse. If one of the sensors on the flowmeter fails, it could result in reverse flow being detected even though it was forward flow.
5. If a flowmeter was recently replaced, make sure it wasn't installed backwards.

## **NO MASTER FLOW**

This fault will only occur on guns configured as 'manual' (also known as demand mode) or Inject mode guns. On guns configured in manual or inject mode, as soon as the gun is put in run mode, the master channel MVR valve opens to the MVR high setpoint (on RansPulse units, the master channel CCV valve opens). In this way, the operators can demand as much fluid as they wish and all the controller does is insure proper ratio by adjusting the MVR on the catalyst side, (or pulsing the inject valve) based on the flow rate of the resin. It is possible, however, for the master channel flowmeter gears to get stuck and still allow material to pass through the flow meter. When this happens, the applicator continues to get resin but the controller is not aware material is flowing as the flow meter is not sending any pulses back to the controller. Therefore, it does not open the catalyst MVR (or inject valves) and ratio in any catalyst. You, therefore, get uncatalyzed parts. To prevent this from happening, air flow switches are supplied that should be tubed in the atomization air line of the applicators. When the handgun or handguns are triggered these switches send a signal into the controller indicating that the handgun is in the triggered state. When the controller gets a trigger signal from the gun, it immediately looks to see if the resin flow meter is turning. If it is not, it issues a NO MASTER FLOW fault.

In many cases, however, operators use their handguns to blow dust and water off of their parts before spraying. They do this by pulling the trigger on the gun back just far enough to get atomization air but no paint. When this happens, the controller gets a trigger signal and no paint flow, which will cause it to fault. To allow for this blow off of parts, a parameter called BLOW OFF TIME has been added to the software (found on the Gun Parameters screen). As soon as the 2k sees flow on the resin flow meter, this timer is reset, and it will start counting again, the next time it sees a trigger without flow.

If you receive this fault, it indicates that the gun has been triggered for the period of time specified by the BLOW OFF TIME parameter, but did not see any resin flow during that time.

In most cases, the cause of this is that the gears in the master channel flow meter have stopped (or become stuck). Try flushing the system and watch the flow rate or flow volume on the main screen of the controller during the flush to see if there is flow on the master channel. If there still is no flow, disassemble and clean the flowmeter. If this still does not correct the problem, see the section in this manual on FLOW TOO LOW FAULTS. If this fault occurs while the operator was not even trying to spray, then the air flow switch may be defective. This can be verified by looking at Force I/O screen (for inputs) A check mark will show up next to the Trigger input when the controller receives a trigger signal from the air flow switch. Verify that the signal turns ON and OFF as the applicator is triggered ON and OFF.

## Section 7: APPENDIX

### Icon Definitions



**CONFIGURE**



**REPORTS**



**COLOR CHANGE SEQUENCER**



**TOOLS / DOSING VALVE STATE**



**EMULATOR**



**RETURN TO HOME SCREEN**



**GO BACK ONE SCREEN**



**BACKUP PARAMETERS TO USB PORT**



**RESTORE PARAMETERS FROM USB PORT**

## Icon Definitions (continued)



**WRITE DISPLAYED PARAMETERS TO OPERATING GUN**



**ADVANCED PARAMETERS**



**RETURN TO ALARMS SCREEN**



**FLOW TOTALS**



**INFORMATION SCREEN**



**TIMER START or TIME VS. VOLUME FOR COLOR CHANGE SEQUENCES**



**VALVE SELECT (X = VALVE OPEN)**



**CLEAR VALUES (SET TO ZERO)**



**FORCE I/O SCREEN**

## Icon Definitions (continued)



**RUN**



**HALT**



**LOAD**



**RESET**



**JOB SELECT**



**FLUSH**



**REMOTE OPERATOR PANEL (ENABLE / TURN ON)**

## Remote Operator Panel (ROP) Error Codes

### ERROR CODE

### DESCRIPTION

1	Ratio Out of Tolerance
2	Reverse Flow Limit
3	Flow Too Low
4	Flow Too High
5	Integrator Too Low (PID Loop Ki set too low)
6	No Job Loaded
7	Potlife Expired
8	Bad Job Format
9	Startup Reset
10	No Master Flow
11	Not in Flush Box A
12	Not in Flush Box B

## High Voltage Interlock Valve

Normal use of handheld applicators requires the product to go through color changes. During the color change sequence, there may be solvent involved to properly clean all the fluid passages. When solvent is present in the color change process, the electrostatics to the applicator must be off (Refer to the warnings in the applicable applicator manual). A new normally open valve package was released for use with applicators during the color change process. The A12613-00 (1/4" ODT pilot) and the A12613-01 (6mm ODT pilot) were released for applications that require interlock equipment. Figure 1 shows the features of the A12613 valve assembly.

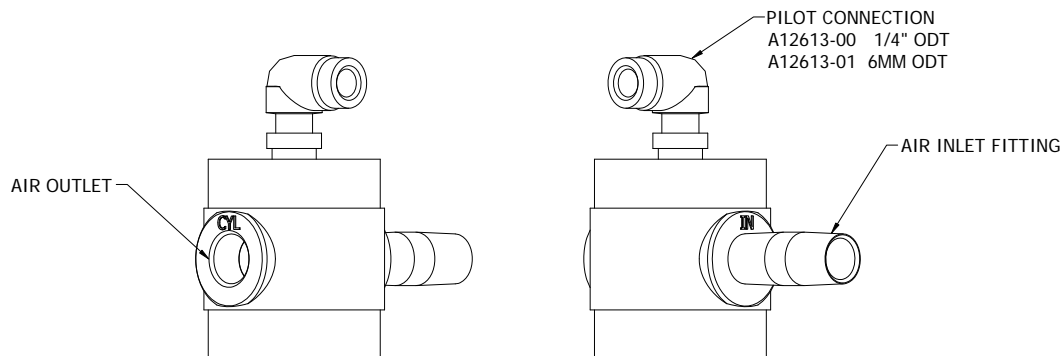

**Figure 1- A12613 VALVE FEATURES**

### **RansFlow Connection**

When manual applicators are used, the valve assembly is installed by threading the "CYL" port of the above valve onto the inlet of the air flow switches on the bottom of the RansFlow or RansPulse control console. A connection tube is required and must be either 6mm or 1/4" ODT and connect from the "DUMP" port on the RansFlow to the pilot connection on the A12613 valve.

If more than one applicator is used from the RansFlow, then a second valve assembly must be installed and the pilot lines connected together using a pneumatic "T" connection.



## Warranty Policies

### **LIMITED WARRANTY**

Ransburg will replace or repair without charge any part or equipment that fails within the specified time (see below) because of faulty workmanship or material, provided that the equipment has been used and maintained in accordance with Ransburg's written safety and operating instructions, and has been used under normal operating conditions. Normal wear items are excluded.

### **THE USE OF OTHER THAN RANSBURG APPROVED PARTS VOIDS ALL WARRANTIES.**

**SPARE PARTS:** One hundred and eighty (180) days from date of purchase, except for rebuilt parts (any part number ending in "R") for which the warranty period is ninety (90) days.

**EQUIPMENT:** When purchased as a complete unit, (i.e. guns, power supplies, control units, etc.), is one (1) year from date of purchase.

### **WRAPPING THE APPLICATOR, ASSOCIATED VALVES AND TUBING, AND SUPPORTING HARDWARE IN PLASTIC, SHRINK WRAP, OR ANY OTHER NON-APPROVED COVERING WILL VOID THIS WARRANTY.**

**RANSBURG'S ONLY OBLIGATION UNDER THIS WARRANTY IS TO REPLACE PARTS THAT HAVE FAILED BECAUSE OF FAULTY WORKMANSHIP OR MATERIALS. THERE ARE NO IMPLIED WARRANTIES NOR WARRANTIES OF EITHER MERCHANTABILITY OR FITNESS FOR A PARTICULAR PURPOSE. RANSBURG ASSUMES NO LIABILITY FOR INJURY, DAMAGE TO PROPERTY OR FOR CONSEQUENTIAL DAMAGES FOR LOSS OF GOODWILL OR PRODUCTION OR INCOME, WHICH RESULT FROM USE OR MISUSE OF THE EQUIPMENT BY PURCHASER OR OTHERS.**

### **EXCLUSIONS:**

If, in Ransburg's opinion the warranty item in question, or other items damaged by this part was improperly installed, operated or maintained, Ransburg will assume no responsibility for repair or replacement of the item or items. The purchaser, therefore will assume all responsibility for any cost of repair or replacement and service related costs if applicable.

# RansFlow & RansPulse Fluid Metering Systems

## Drawings and Spare Parts

SERVICE MANUAL

LN-9409-01.4

April-2014

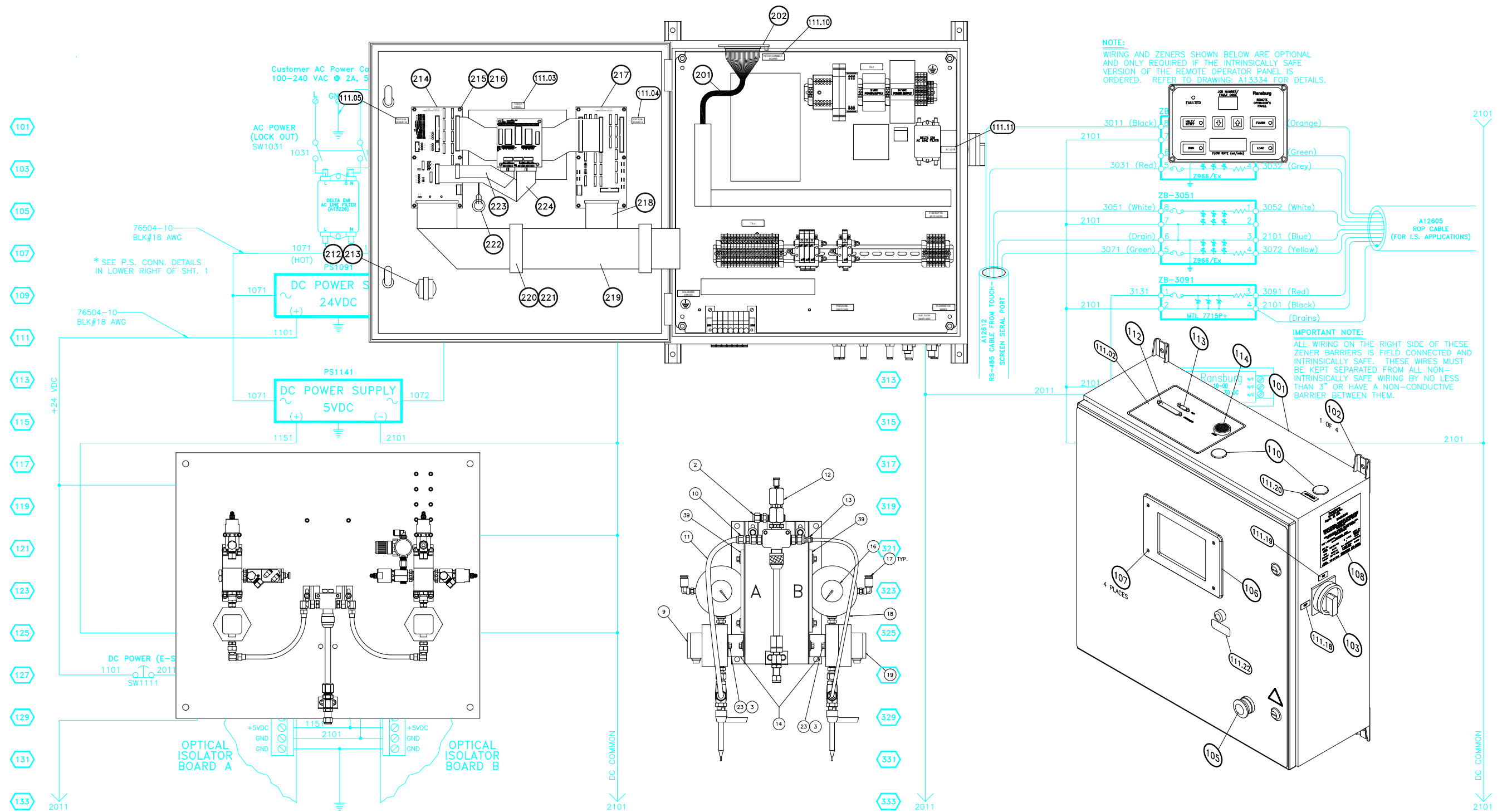

MODELS: A12410 (RansFlow)  
A13334 (RansPulse)

## NOTES

**Contents**

**RansFlow Fluid Panel.....5-10**

**RansFlow Control Panel.....11-18**

**RansFlow Schematics.....19-23**

**RansPulse Control Panel.....24-28**

**RansPulse Schematics.....29-33**

**General Schematics.....34-37**

**RansFlow Spare Parts.....38-39**

**RansPulse Spare Parts.....40-41**

## NOTES

# RansFlow Fluid Panel

Contact Technical Support for the RansPulse Fluid Panel Manual

(TABLE A) A SIDE, FLOW METER

Table with 9 columns: DASH NO., DESCRIPTION, A, H, W, A4, B1, B2, B3. Rows include NONE, ZHM-02, RF-1 F.O., PISTON METER, RF-1 STD.

(TABLE C) B SIDE, FLOW METER

Table with 9 columns: DASH NO., DESCRIPTION, A, H, W, A4, B1, B2, B3. Rows include NONE, ZHM-02, RF-1 F.O., PISTON METER, RF-1 STD.

(TABLE E) (MIXING BLOCK)

Table with 5 columns: DASH NO., DESCRIPTION, G, X QTY., Y QTY. Rows include MIX BLOCK (FLUSHABLE), MIX BLOCK (NON-FLUSHABLE), MIX BLOCK, HIGH PRESSURE ONLY.

(TABLE F)

Table with 17 columns: DASH NO., DESCRIPTION, SEE SHT, G, I, K, L, M, N, O, P, Q, R, S, T, A1, A2, A3, A5, A6. Rows include LOW PRESSURE, PISTON, HIGH PRESSURE.

2 ON 78137-XX ASSEMBLES POSITION THE DRAIN VALVE DOWNWARD (77767-01 ELBOW) ONCE MOUNTED ONTO FLUID PANEL.

1 DURING ASSEMBLY OF RF FLOWMETER, OBSERVE FLUID FLOW DIRECTION BY "ARROW" ON METER.

0

9 APPLY 77715-00 (REF) ON UPPER LEFT HAND CORNER OF PANEL

8 TORQUE FITTING TO 50 FT. LBS

7 APPLY AMOJELL (SSL-11) ONTO TAPER OF FITTING PRIOR TO ASSY TO PREVENT GALLING.

6 ATTACH 78214-00 TAG TO FLUID INPUTS.

5. TUBING OMITTED FROM SIDE VIEWS FOR CLARITY.

4. PURCHASE SEPARATELY: TR-200963-XX (STANDARD FLOWMETER CABLE) 77219 (PISTON FLOWMETER CABLE) TR-SSEH-739 (TRANSDUCER CABLE)

3. NO SILICON LUBRICANTS ARE TO BE USED ON ANY OF THESE COMPONENTS.

2. USE PIPE SEALANT, 7969-10, OR EQUAL ON ALL SS NPT THD'S UNLESS OTHERWISE NOTED.

1. WHEN ORDERING, USE 78787-AABCCDEF AS INDICATED BY TABLES A THRU F:

TABLE A DESIGNATES THE "A" SIDE FLOW METER
TABLE B DESIGNATES THE "A" SIDE FLOW CONTROL
TABLE C DESIGNATES THE "B" SIDE FLOW METER
TABLE D DESIGNATES THE "B" SIDE MVR
TABLE E DESIGNATES THE MIXING BLOCK
TABLE F DESIGNATES THE PRESSURE

EIGHT CHARACTERS MUST FOLLOW THE BASIC PART NUMBER, IE:

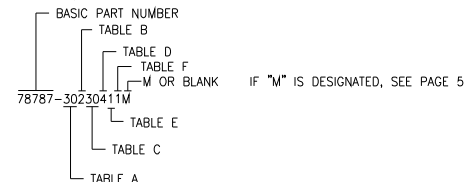

NOTES: UNLESS OTHERWISE SPECIFIED

(TABLE B) A SIDE, FLUID CONTROL

Table with 9 columns: DASH NO., DESCRIPTION, E, Z QTY., U QTY., V QTY., X QTY., Y QTY., C QTY. Rows include NONE, #2-#4 WEEPLESS MVR, #2-#4 WEEPING MVR, CCV FLUID CONTROL.

(TABLE D) B SIDE, MVR

Table with 6 columns: DASH NO., DESCRIPTION, B, C QTY., Z QTY., U QTY., V QTY. Rows include NONE, #2-#4 WEEPLESS MVR, #2-#4 WEEPING MVR.

(RF-1 FIBER OPTIC ASSM)

Table with 3 columns: DASH NO., CABLE LENGTH, AA. Rows include 10 FT., 15 FT., 30 FT., 45 FT., 60 FT., 100 FT.

(RF-1 STD CABLE ASSM)

Table with 3 columns: DASH NO., CABLE LENGTH, BB. Rows include 10 FT., 11 FT., 40 FT., 41 FT.

(TABLE F) (CONT.)

Table with 5 columns: DASH NO., A7, A8, A9, A10. Rows include 1, 2, 3.

Large table with 4 columns: DASH NO., PART No., DESCRIPTION, QTY. Rows include 52-51, 50, 49, 48, 47, 46, 45, 44, 43, 42, 41, 40, 39, 38, 37, 36, 35, 34, 33, 32, 31, 30, 29, 28, 27, 26, 25, 24, 23, 22, 21, 20, 19, 18, 17, 16, 15, 14, 13, 12, 11, 10, 9, 8, 7, 6, 5, 4, 3, 2, 1, ITEM No., PART No., DESCRIPTION, QTY.

RansFlow Fluid Panel Bill of Materials

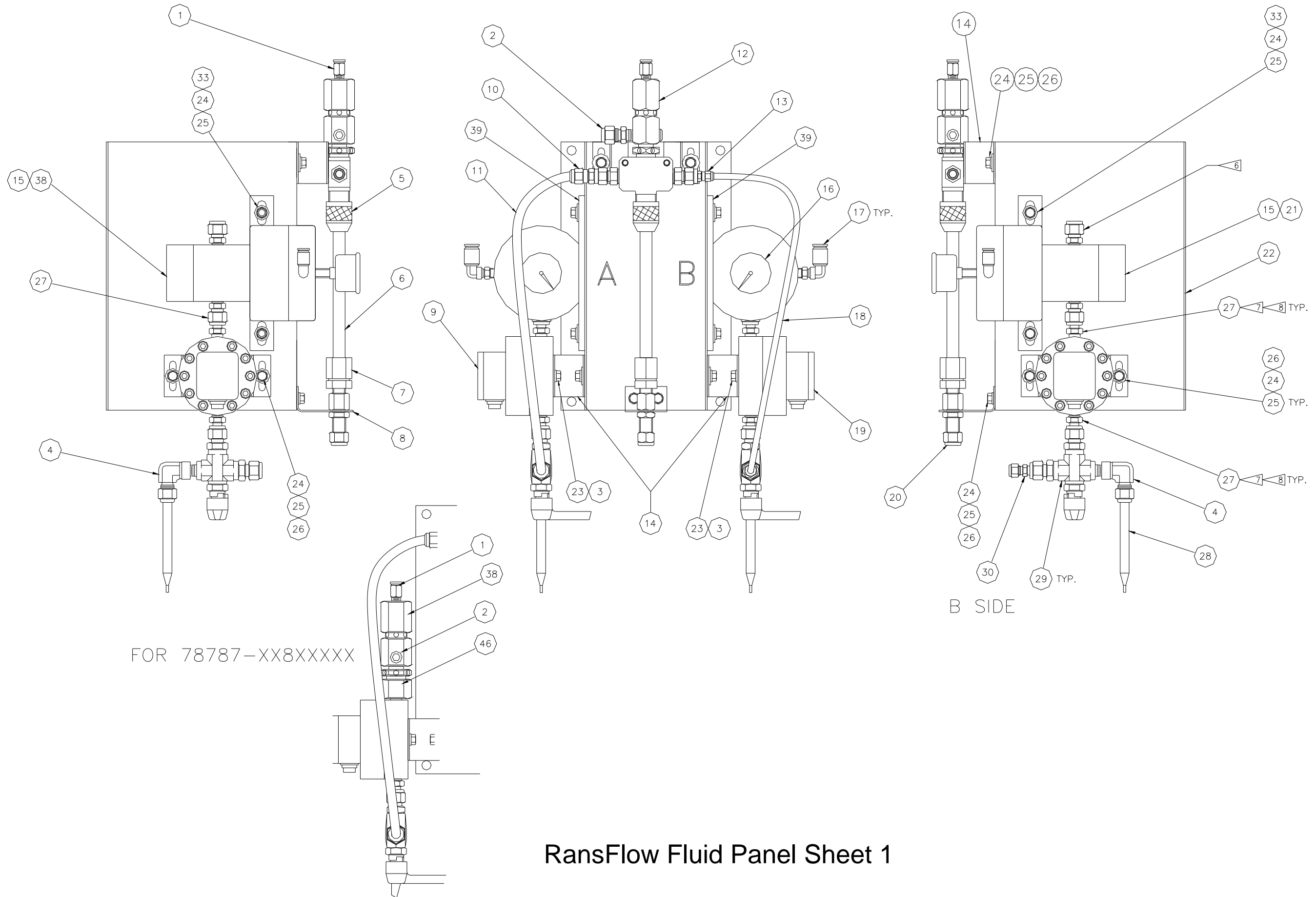

RansFlow Fluid Panel Sheet 1



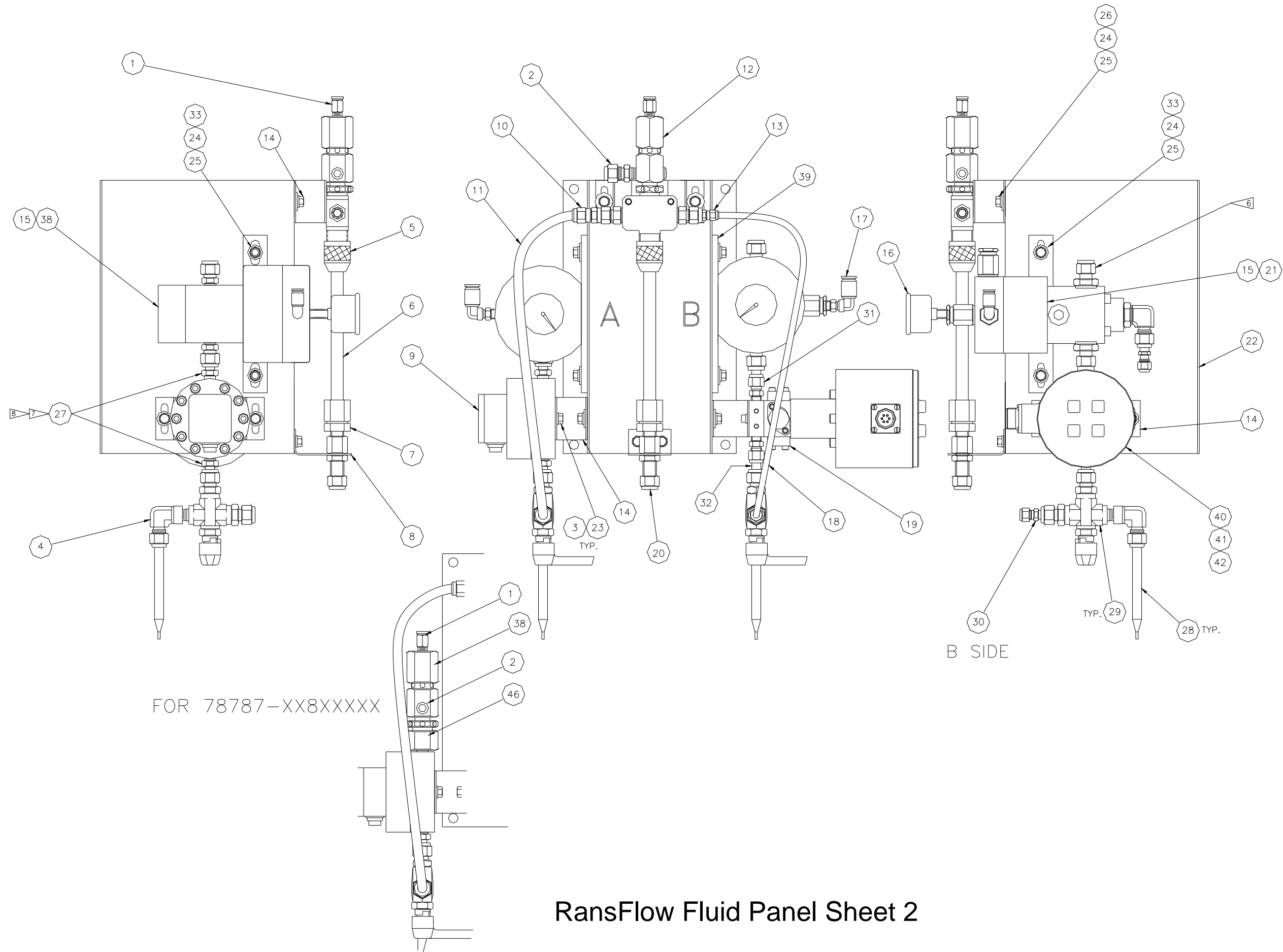

RansFlow Fluid Panel Sheet 2

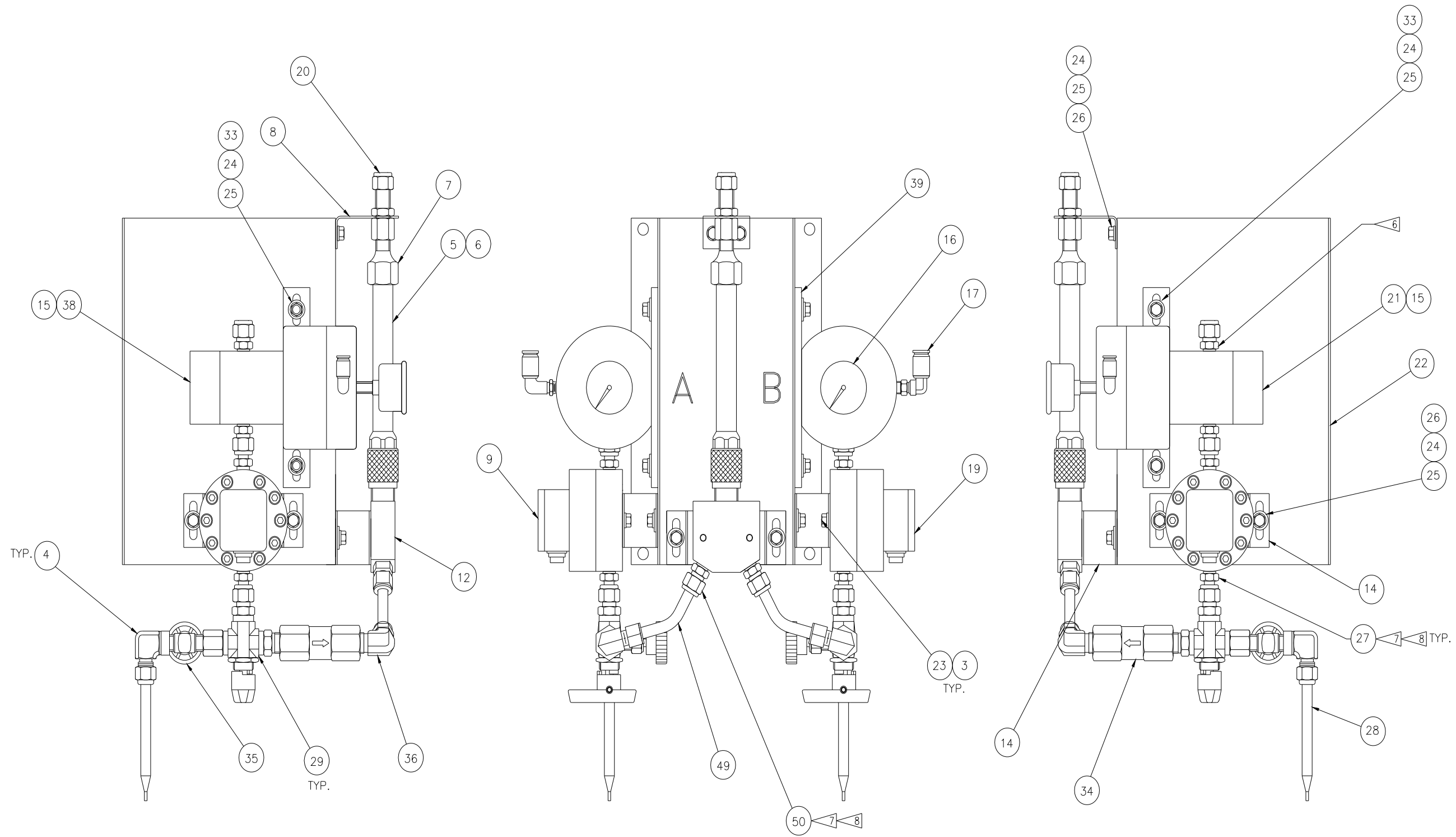

RansFlow Fluid Panel Sheet 3

TABLE "H"

ITEM NO.	PART NUMBER	QTY NO.	DESCRIPTION
1	A12592-06	4	3/8 ODT TO 10MM CONVERSION
2	41-FTP-1006	3	NPT TO 4MM CONVERSION
3	A12593-04	3	4MM TO 6MM ODT CONVERSION

FOR PANELS WITH DUAL MVR ASSEMBLIES

REMOVE AND REPLACE FITTINGS AND  
INSTALL OTHER FITTINGS AS SHOWN IN  
FIGURE 1-1  
REFERENCE TABLE "H"

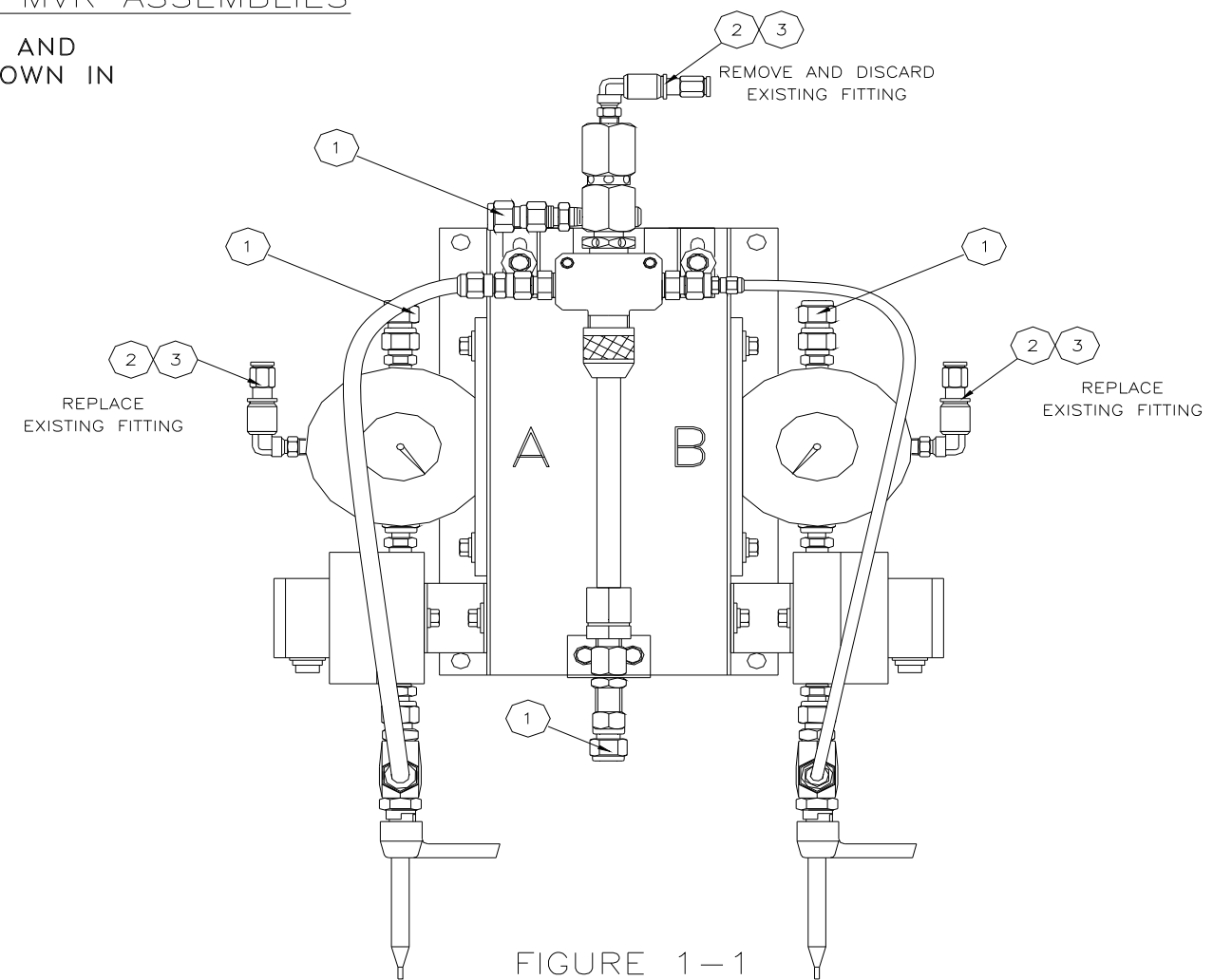

FIGURE 1-1

FOR PANELS W/SINGLE MVR ASSEMBLY

REMOVE AND REPLACE FITTINGS AND  
INSTALL OTHER FITTINGS AS SHOWN IN  
FIGURE 1-2  
REFERENCE TABLE "H"

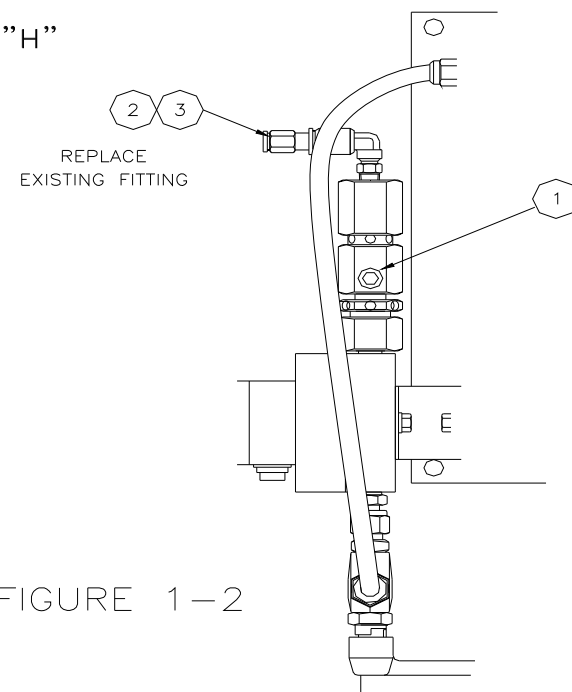

FIGURE 1-2

THIS PAGE IS FOR METRIC PANELS ONLY

RansFlow Fluid Panel Sheet 4

# **RansFlow Control Panel**

ENCLOSURE ASSEMBLY

BACK PANEL ASSEMBLY

DOOR ASSEMBLY

TOP LEVEL ASSEMBLY (A12410)

Main assembly table with columns: ITEM, QTY, PART NUMBER, DESCRIPTION, ITEM, QTY, PART NUMBER, DESCRIPTION, ITEM, QTY, PART NUMBER, DESCRIPTION, ITEM, QTY, PART NUMBER, DESCRIPTION

FOR ORDERING, USE A12410-ABCDEFGHIJ AS INDICATED BY THE TABLES.
"A" DESIGNATES OPERATION MODE-TABLE A
"B" DESIGNATES NUMBER OF CHANNELS-TABLE B
" C" DESIGNATES TYPE OF FLOW METER-TABLES C, D & E
"D" DESIGNATES NUMBER OF COLOR SOLENOID VALVES-TABLE F
"E" DESIGNATES INLET PRESSURE CONTROL-TABLE H
"F" DESIGNATES REMOTE OPERATOR PANEL-TABLE G

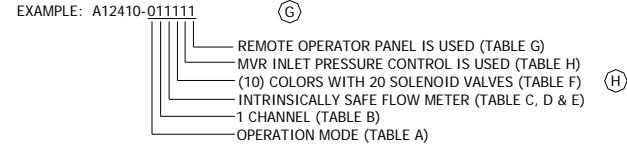

TABLE A - OPERATION MODE
"A" DASH No. DESCRIPTION J K L M N
0 MANUAL 2 2 2 4 10
1 AUTOMATIC 0 0 0 0 6

TABLE B - FLOW CHANNEL QUANTITIES
"B" DASH No. D E F
1 1 2 3
2 2 4 4
3 3 6 5

TABLE C - NON INTRINSIC QUANTITIES
"E" DASH No. A B Y
-X10XXXX 33 0 3
-X20XXXX 35 0 3
-X30XXXX 37 0 3

TABLE D - INTRINSIC QUANTITIES
"E" DASH No. A B Y
-X11XXXX 32 2 3
-X21XXXX 32 3 3
-X31XXXX 32 5 3

TABLE E - FIBER OPTIC QUANTITIES
"E" DASH No. A B C Y Z
-X12XXXX 34 0 1 0 3
-X22XXXX 34 0 2 0 3
-X32XXXX 34 0 3 0 3

TABLE F - SOLENOID VALVES
"D" DASH No. G H Q
0 0 0 0
1 2 20 1

TABLE G - ROP TABLE
"F" DASH No. DESCRIPTION "AA" "AB" "AC" "AD" "AE" "AF" "AG" "AH"
0 NONE 0 0 0 0 0 0 1 0
1 NON-INTRINSICALLY SAFE 1 1 0 0 0 0 1 0
2 INTRINSICALLY 1 0 1 1 2 1 0 1

TABLE H - DR-1 PRESSURE CONTROL
"E" DASH No. R S T U V W X
-X1XXOX 0 0 0 10 3 0 0
-X2XXOX 0 0 0 10 3 0 0
-X3XXOX 0 0 0 10 3 0 0
-X1XX1X 1 1 2 12 4 1 1
-X2XX1X 2 1 2 12 5 2 2
-X3XX1X 3 1 2 12 6 3 3

RansFlow Control Panel Bill of Materials

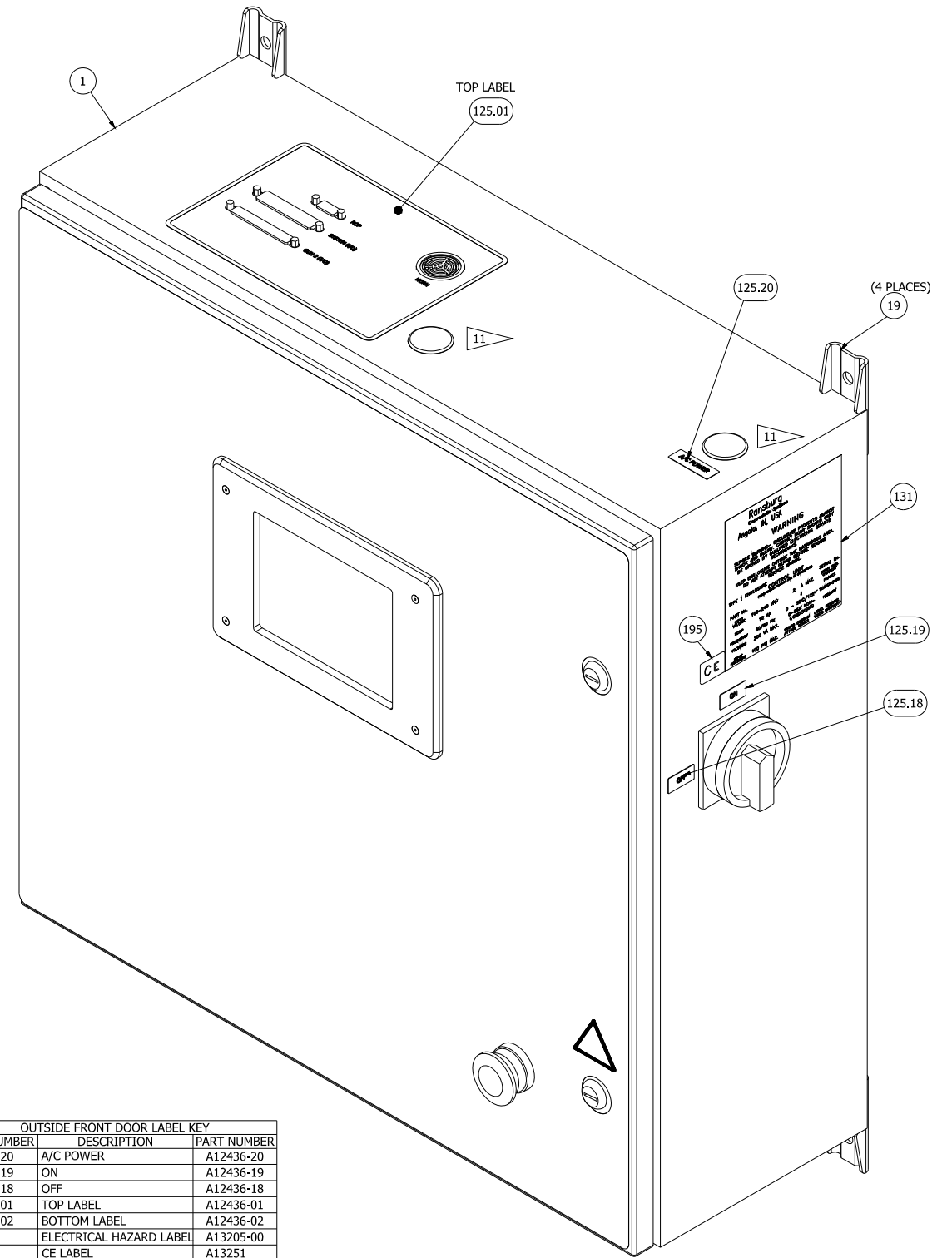
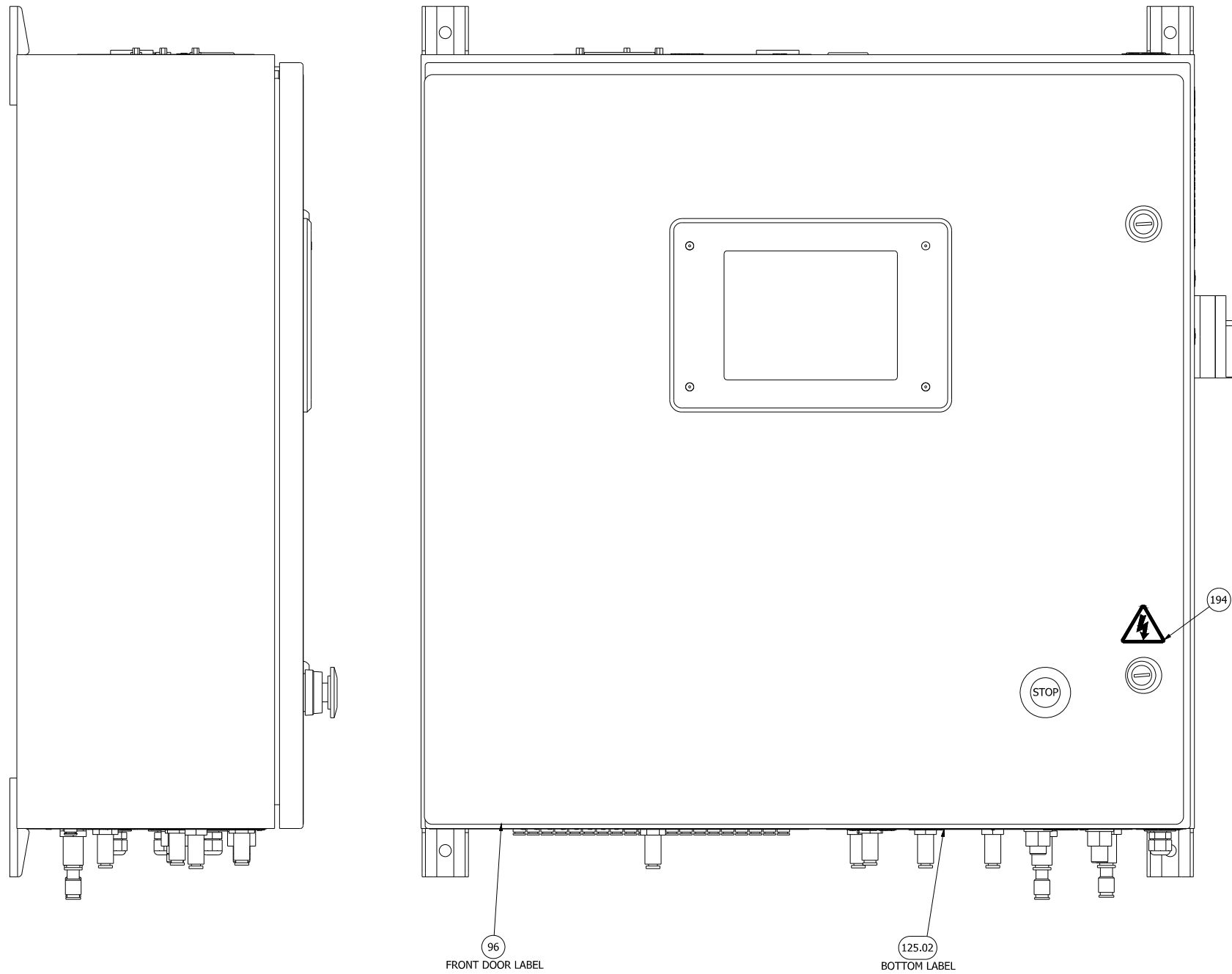

OUTSIDE FRONT DOOR LABEL KEY		
ITEM NUMBER	DESCRIPTION	PART NUMBER
125.20	A/C POWER	A12436-20
125.19	ON	A12436-19
125.18	OFF	A12436-18
125.01	TOP LABEL	A12436-01
125.02	BOTTOM LABEL	A12436-02
194	ELECTRICAL HAZARD LABEL	A13205-00
195	CE LABEL	A13251

## RansFlow Control Panel Sheet 1

SECTION B-B

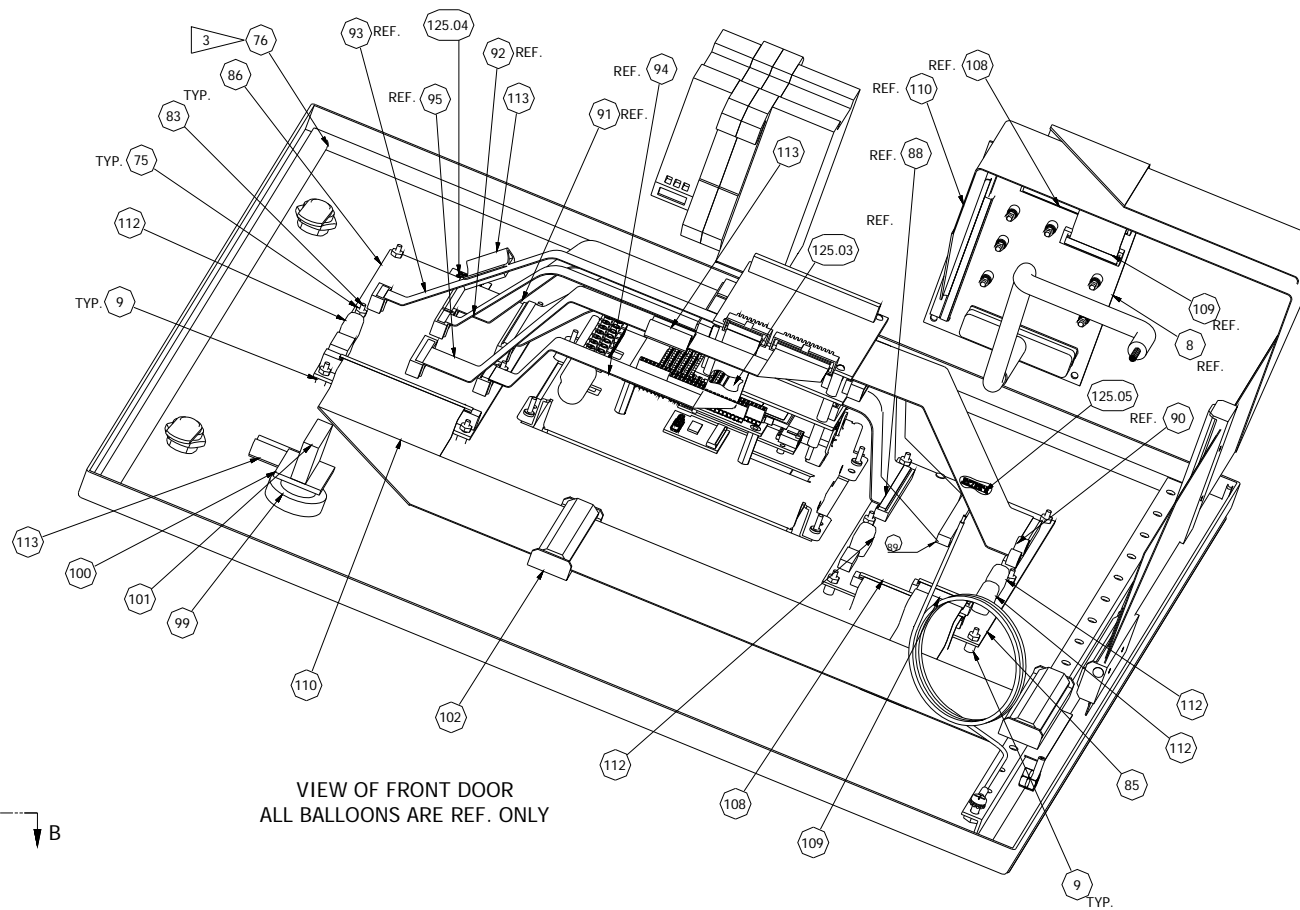
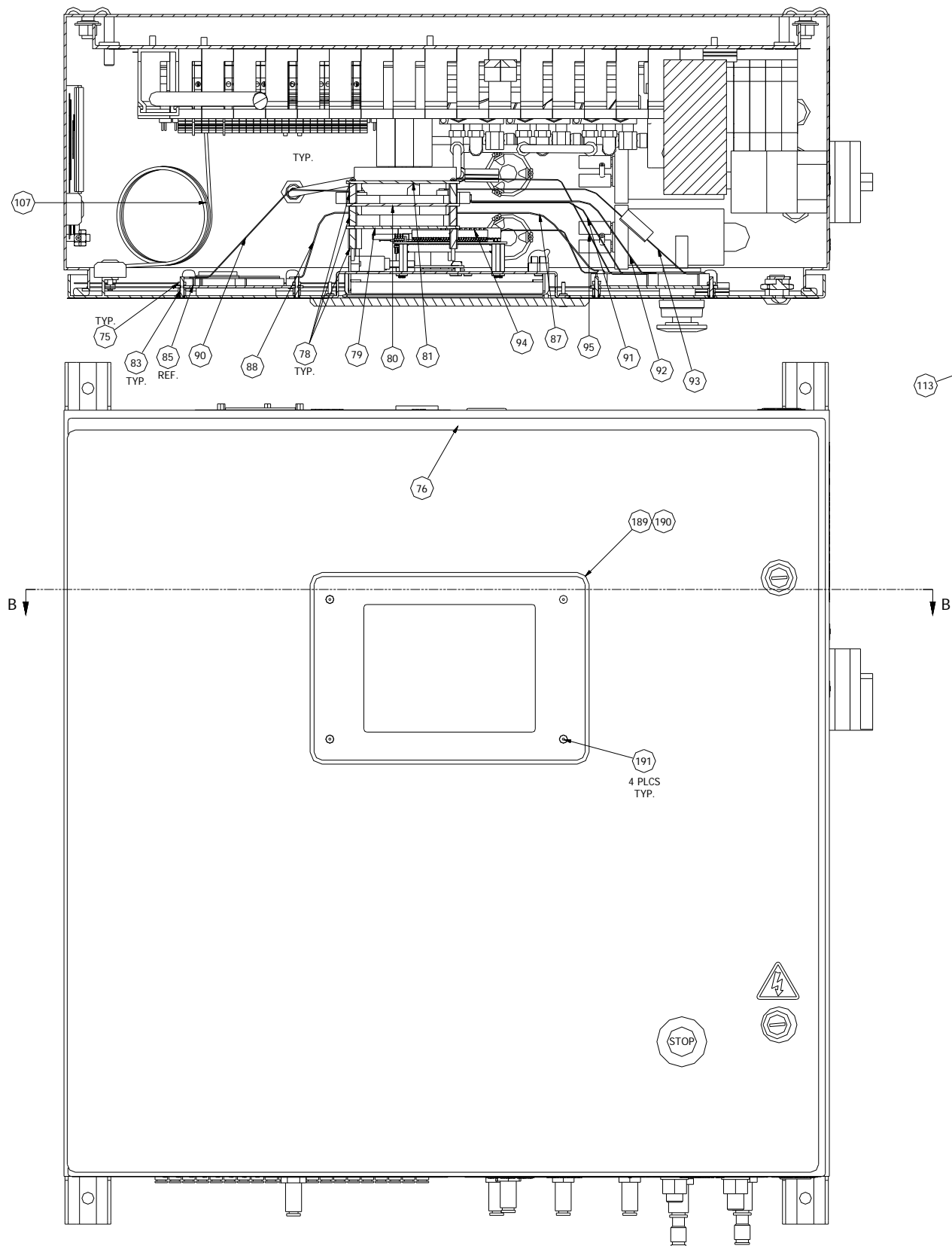

VIEW OF FRONT DOOR  
ALL BALLOONS ARE REF. ONLY

INSIDE FRONT DOOR LABEL KEY		
REFERENCE	DESCRIPTION	PART NUMBER
125.03	TOUCH PANEL	A12436-03
125.04	OPTICAL BOARD A	A12436-04
125.05	OPTICAL PANEL B	A12436-05

RansFlow Control Panel Sheet 2

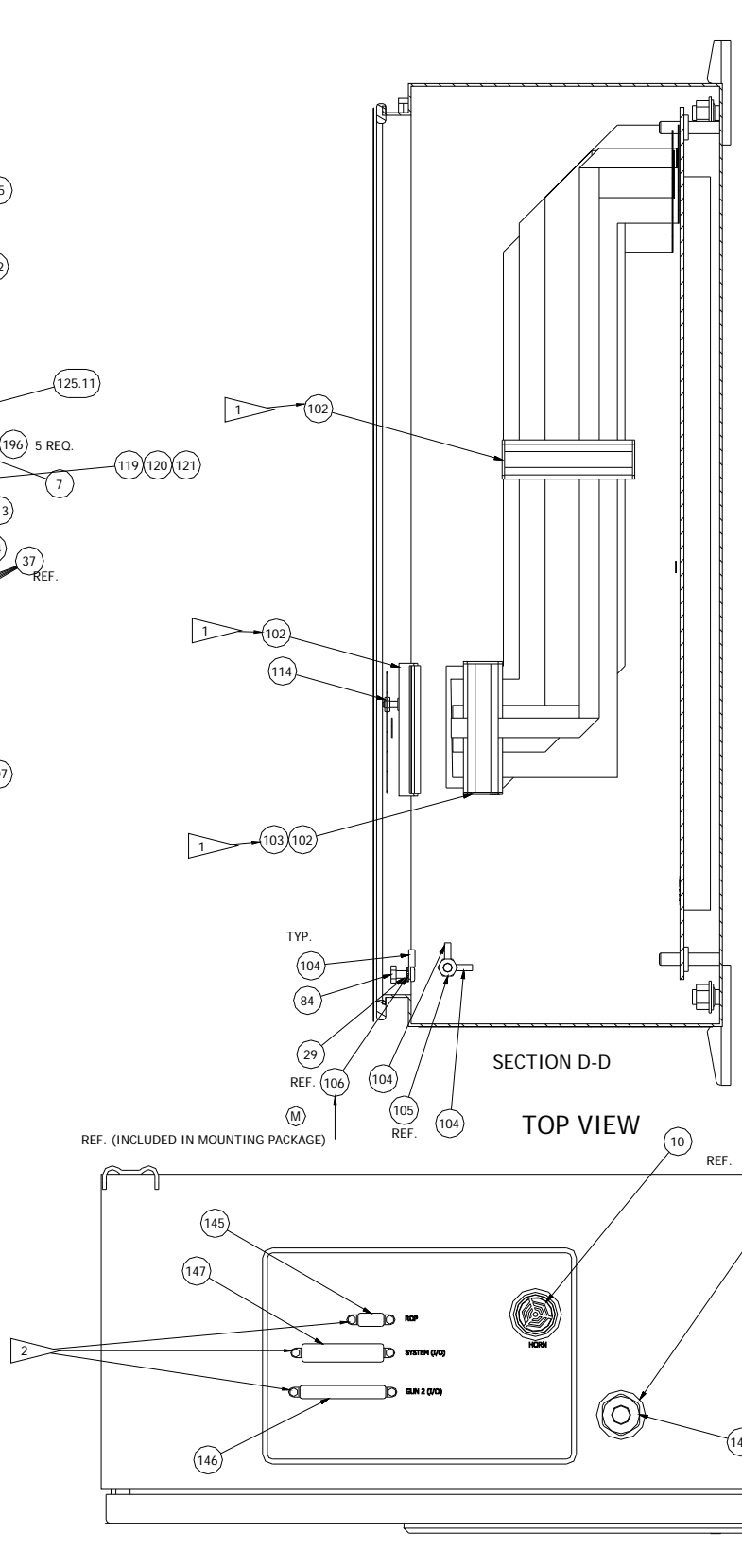
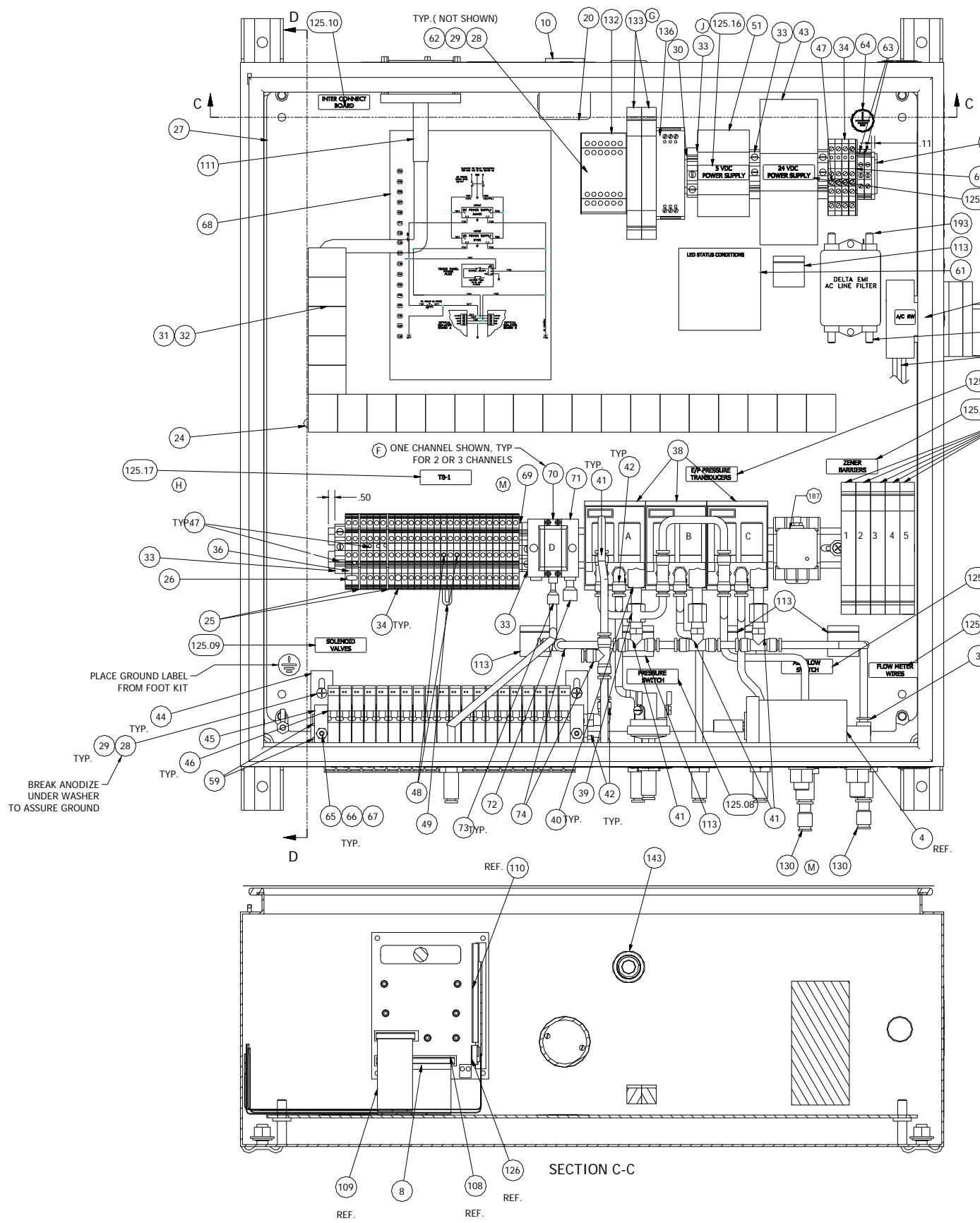

ITEM NUMBER	DESCRIPTION	PART NUMBER
125.06	FLOW METER WIRES	A12436-06
125.07	AIR FLOW SWITCH	A12436-07
125.08	PRESSURE SWITCH	A12436-08
125.09	SOLENOID VALVES	A12436-09
125.10	INTER CONNECT BOARD	A12436-10
125.11	A/C LOCKOUT	A12436-11
125.12	24 VDC POWER SUPPLY	A12436-12
125.13	E/P TRANSDUCERS	A12436-13
125.14	ZENER BARRIERS	A12436-14
125.15	FIBER RECEIVER	A12436-15
125.16	5 VDC POWER SUPPLY	A12436-16
125.17	TB-1	A12436-17

### RansFlow Control Panel Sheet 3



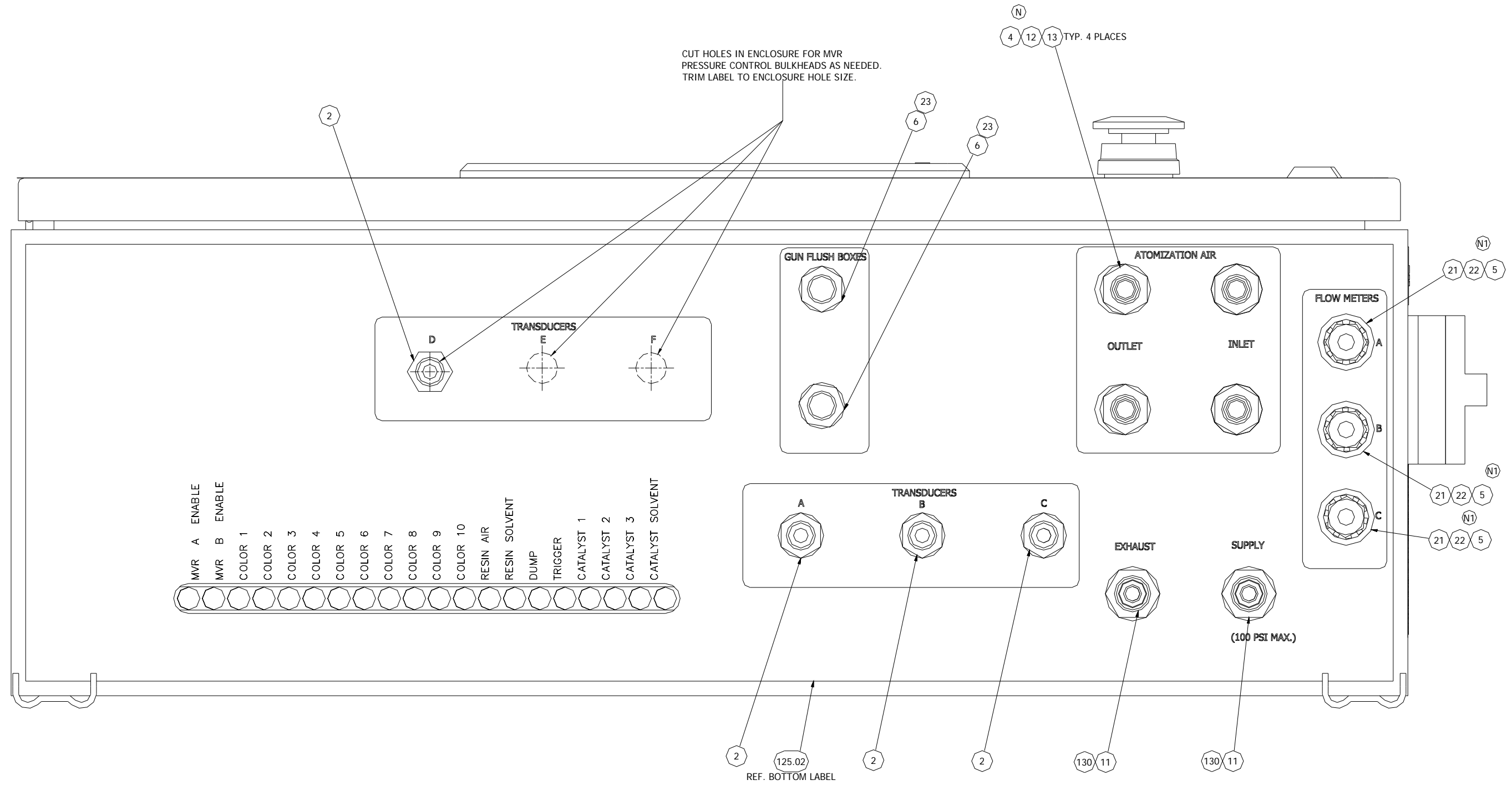

RansFlow Control Panel Sheet 4

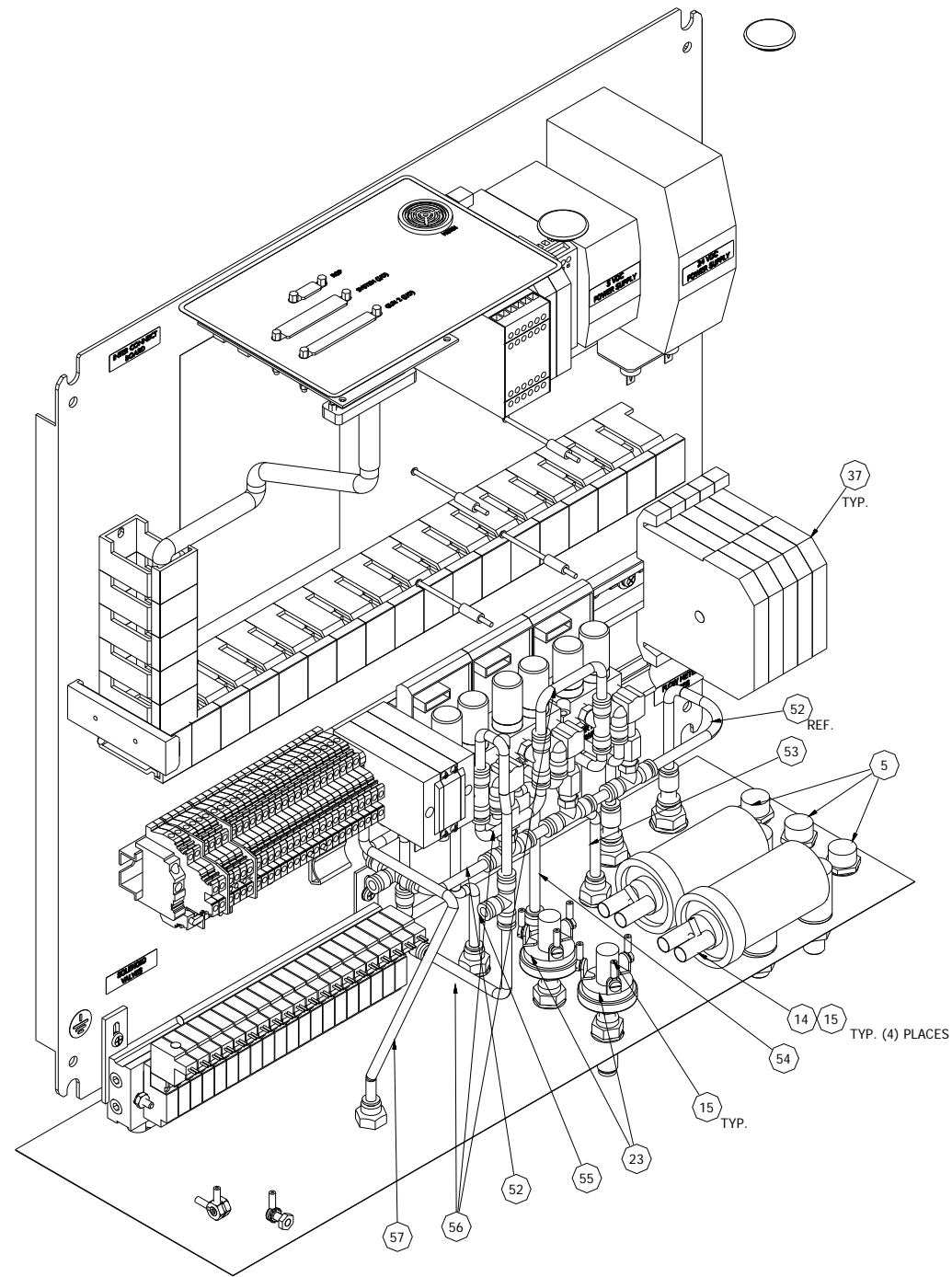

VIEW OF ZENER BARRIER OPTION

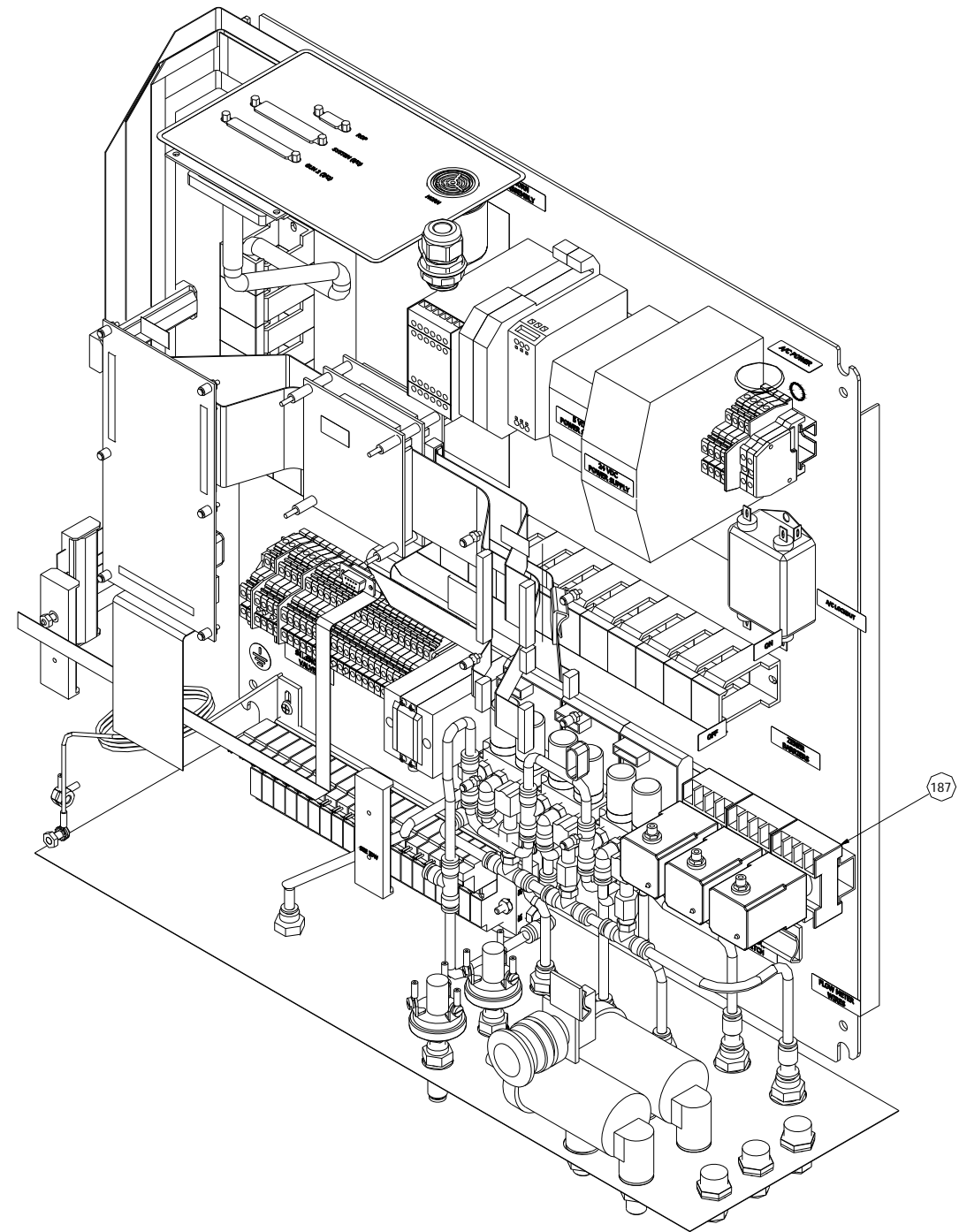

VIEW OF FIBER OPTIC OPTION

PNEUMATIC TUBING CONNECTION CHART 9

PANEL BULKHEADS	MVR TRANSDUCERS	DR1 TRANSDUCERS	SOLENOID VALVE MANIFOLD
SUPPLY →	I →	1 →	1P →
EXHAUST ←	E ←	3 ←	3R ←
TRANSDUCER A ←	O		
TRANSDUCER B ←	O		
TRANSDUCER C ←	O		
TRANSDUCER D ←		2	
TRANSDUCER E ←		2	
TRANSDUCER F ←		2	

## RansFlow Control Panel Sheet 5

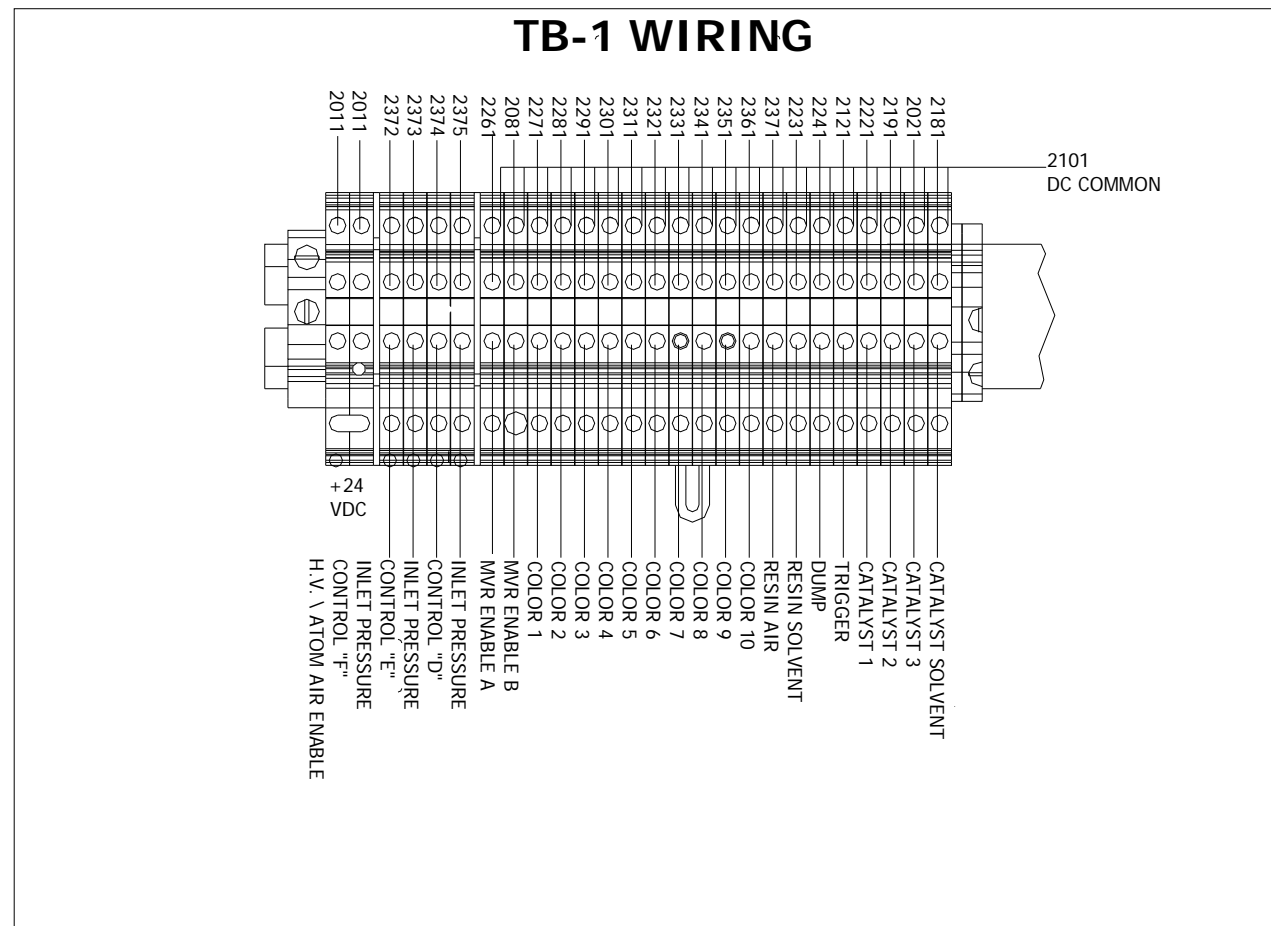
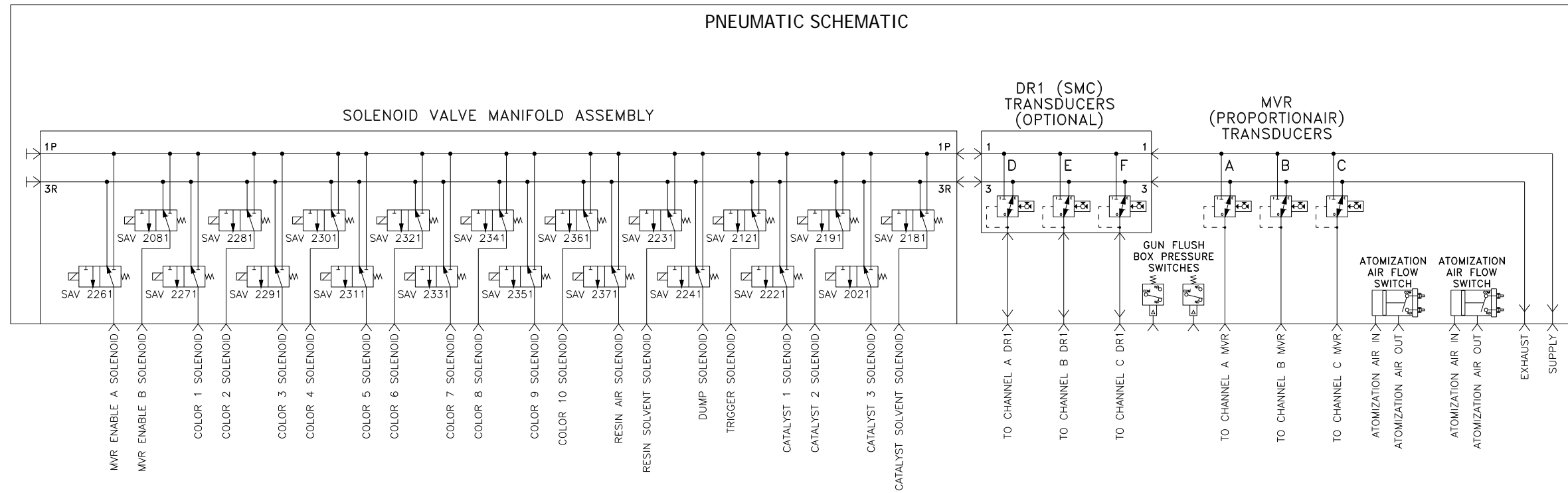

NOTE: REFERENCE ELECTRICAL WIRING SCHEMATIC A12462-00, REMOVE UNWANTED MARKED IN BLOCK OF TB-1 WIRING CHART.

# RansFlow Schematics

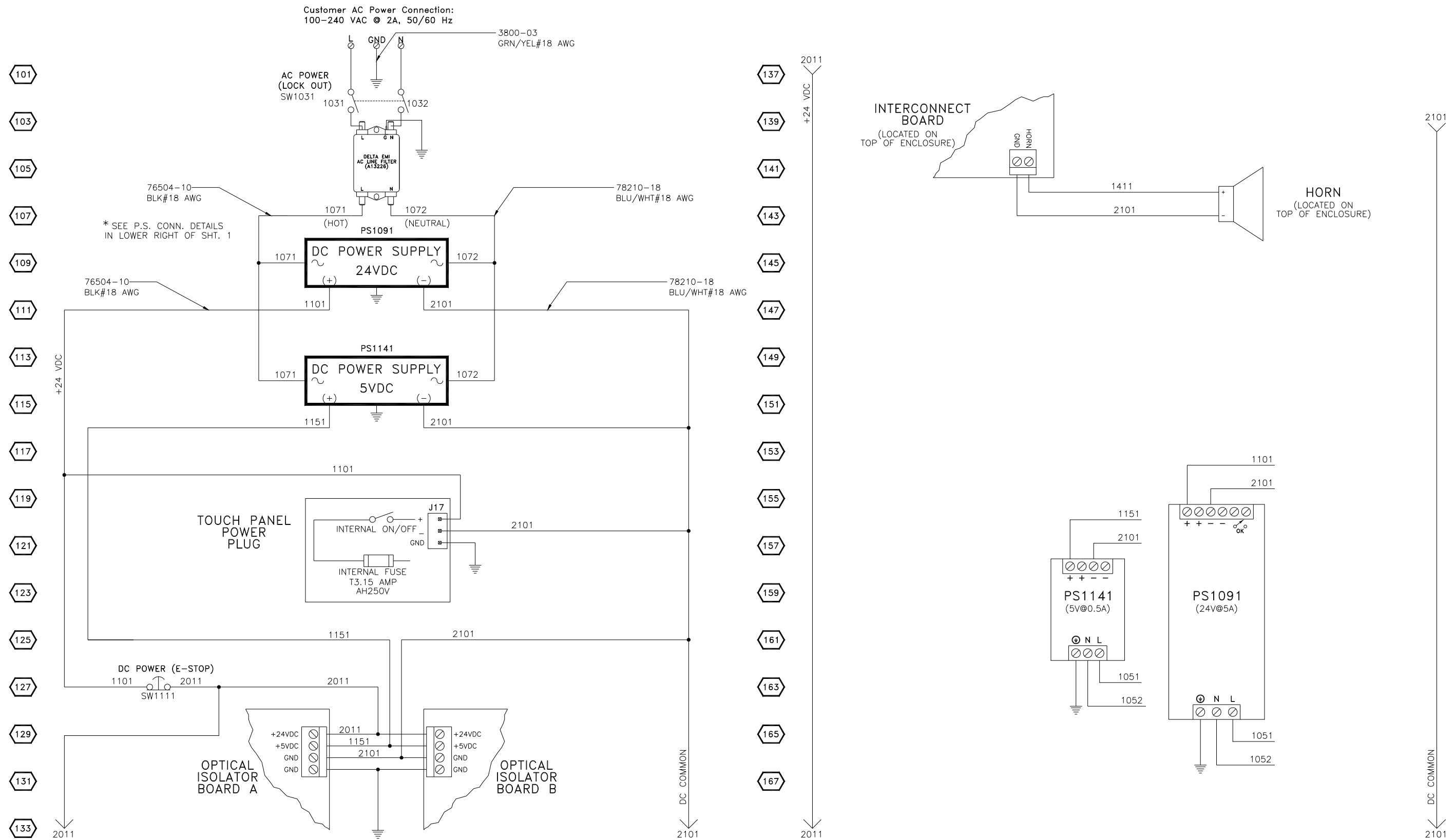

RansFlow Wiring Diagram Sheet 1

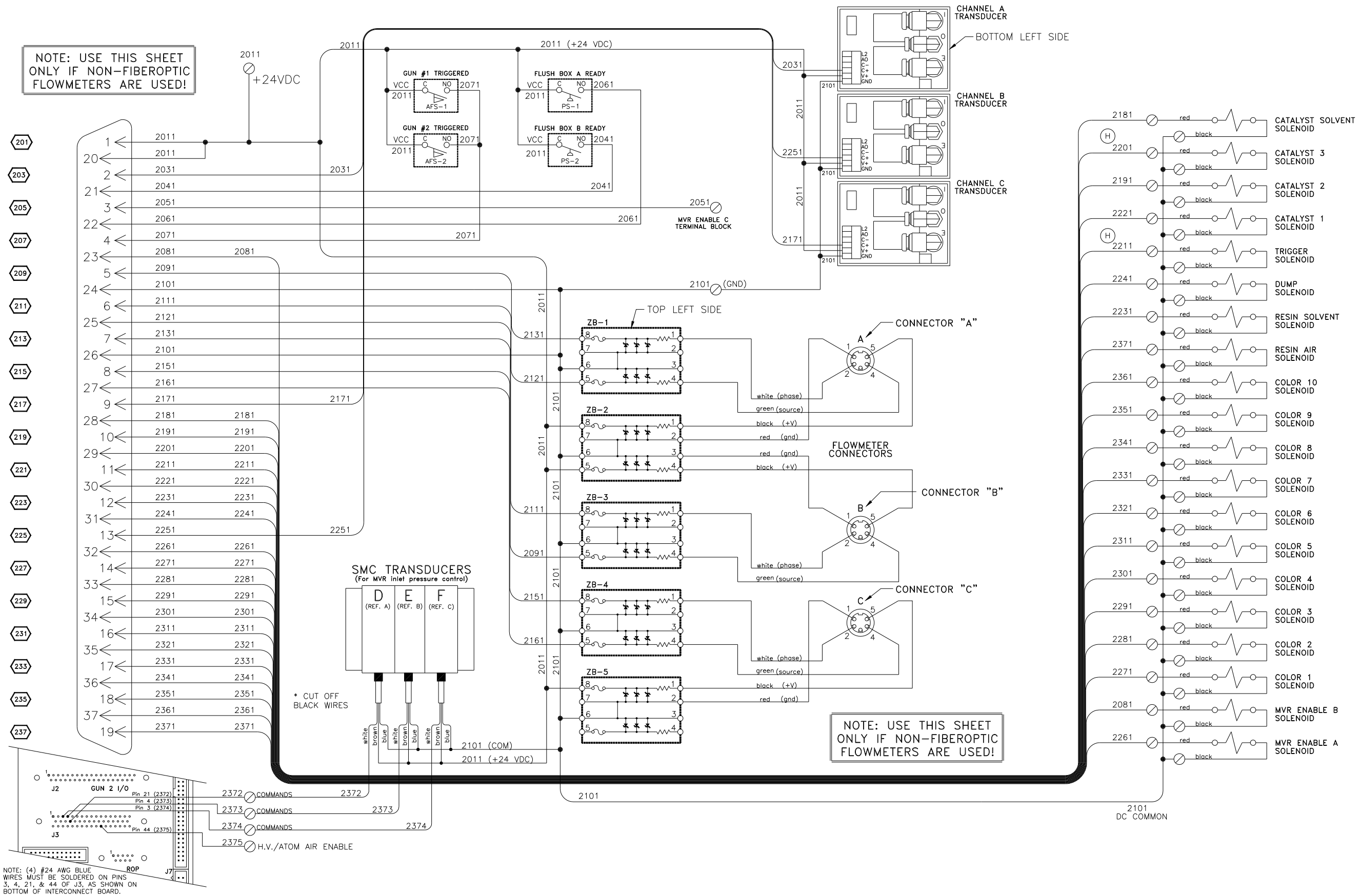

## RansFlow Wiring Diagram Sheet 2

NOTE: USE THIS SHEET ONLY IF FIBEROPTIC FLOWMETERS ARE USED!

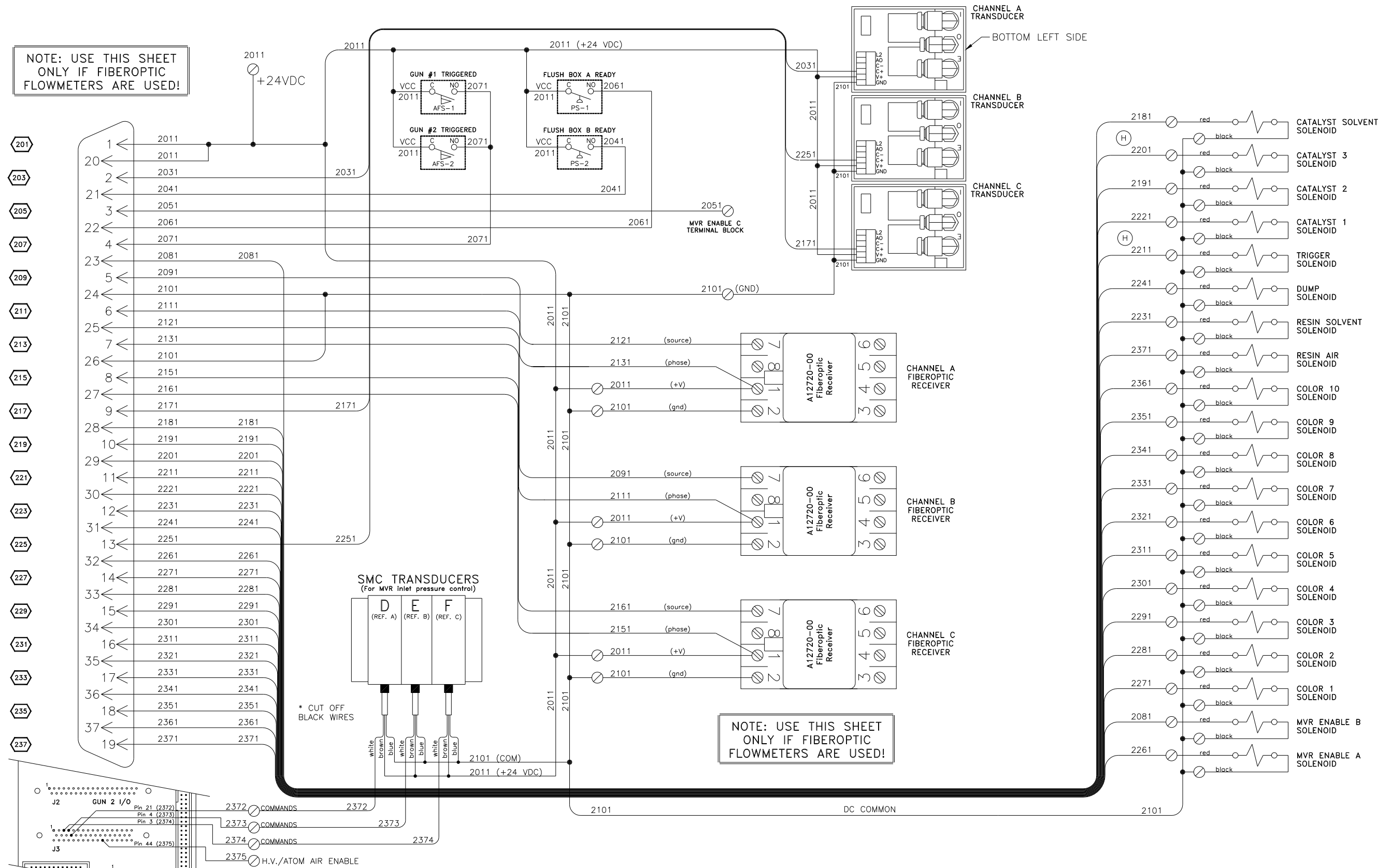

NOTE: (4) #24 AWG BLUE WIRES MUST BE SOLDERED ON PINS 3, 4, 21, & 44 OF J3, AS SHOWN ON BOTTOM OF INTERCONNECT BOARD.

### RansFlow Wiring Diagram Sheet 3

**NOTE:**  
 WIRING AND ZENERS SHOWN BELOW ARE OPTIONAL  
 AND ONLY REQUIRED IF THE INTRINSICALLY SAFE  
 VERSION OF THE REMOTE OPERATOR PANEL IS  
 ORDERED. REFER TO DRAWING: A12410 FOR DETAILS.

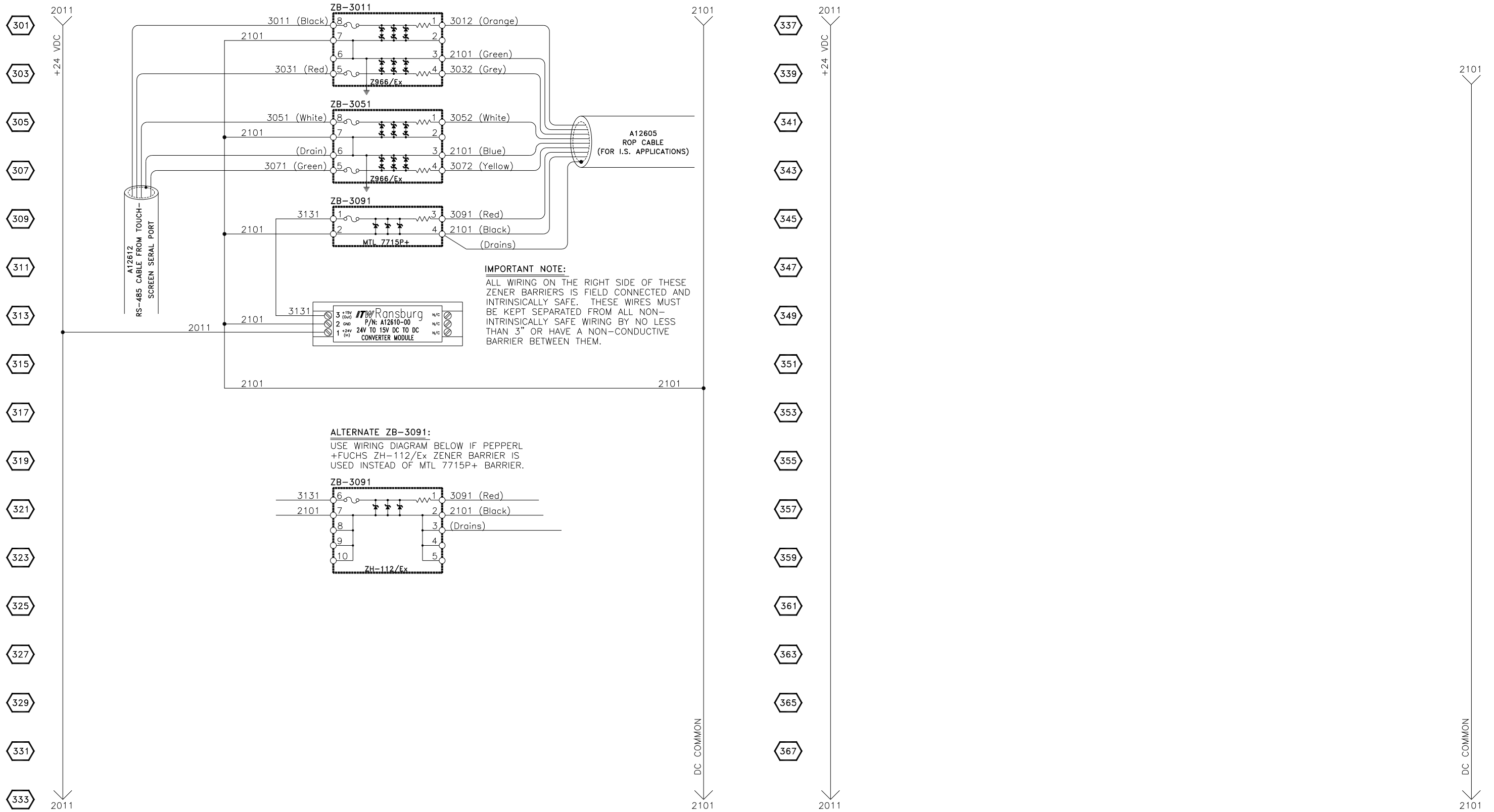

## RansFlow Wiring Diagram Sheet 4



# **RansPulse Control Panel**

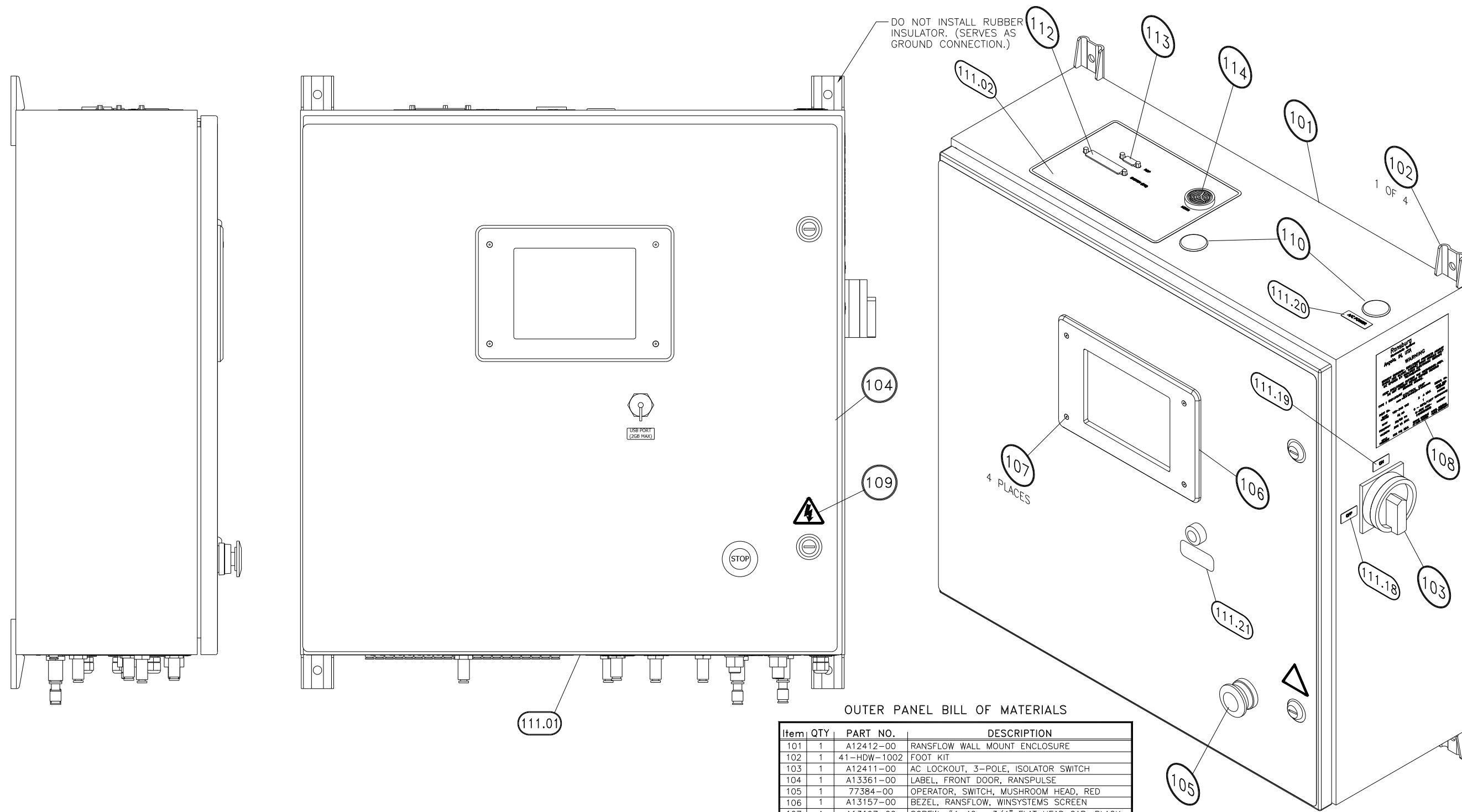

OUTER PANEL BILL OF MATERIALS

Item	QTY	PART NO.	DESCRIPTION
101	1	A12412-00	RANSFLOW WALL MOUNT ENCLOSURE
102	1	41-HDW-1002	FOOT KIT
103	1	A12411-00	AC LOCKOUT, 3-POLE, ISOLATOR SWITCH
104	1	A13361-00	LABEL, FRONT DOOR, RANSPULSE
105	1	77384-00	OPERATOR, SWITCH, MUSHROOM HEAD, RED
106	1	A13157-00	BEZEL, RANSFLOW, WINSYSTEMS SCREEN
107	4	A13197-00	SCREW, #4-40 x 3/4" FLAT HEAD CAP, BLACK
108	1	A12199-01	LABEL, METAL, CONTROL PAK
109	1	A13205-00	LABEL, ELECTRICAL HAZARD
110	2	SSH-7739	CONDUIT HOLE PLUG
111	1	A13344-00	RANSPULSE CONTROL CONSOLE LABEL SET
112	1	A12646-03	DUST CAP FOR DB-37 CONNECTOR
113	1	A12646-01	DUST CAP FOR DB-9 CONNECTOR
114	1	LSME0024-00	HORN

TOP ASSEMBLY PART NUMBER:  
**A13334-ABCDEF**

RansPulse Control Panel Sheet 1

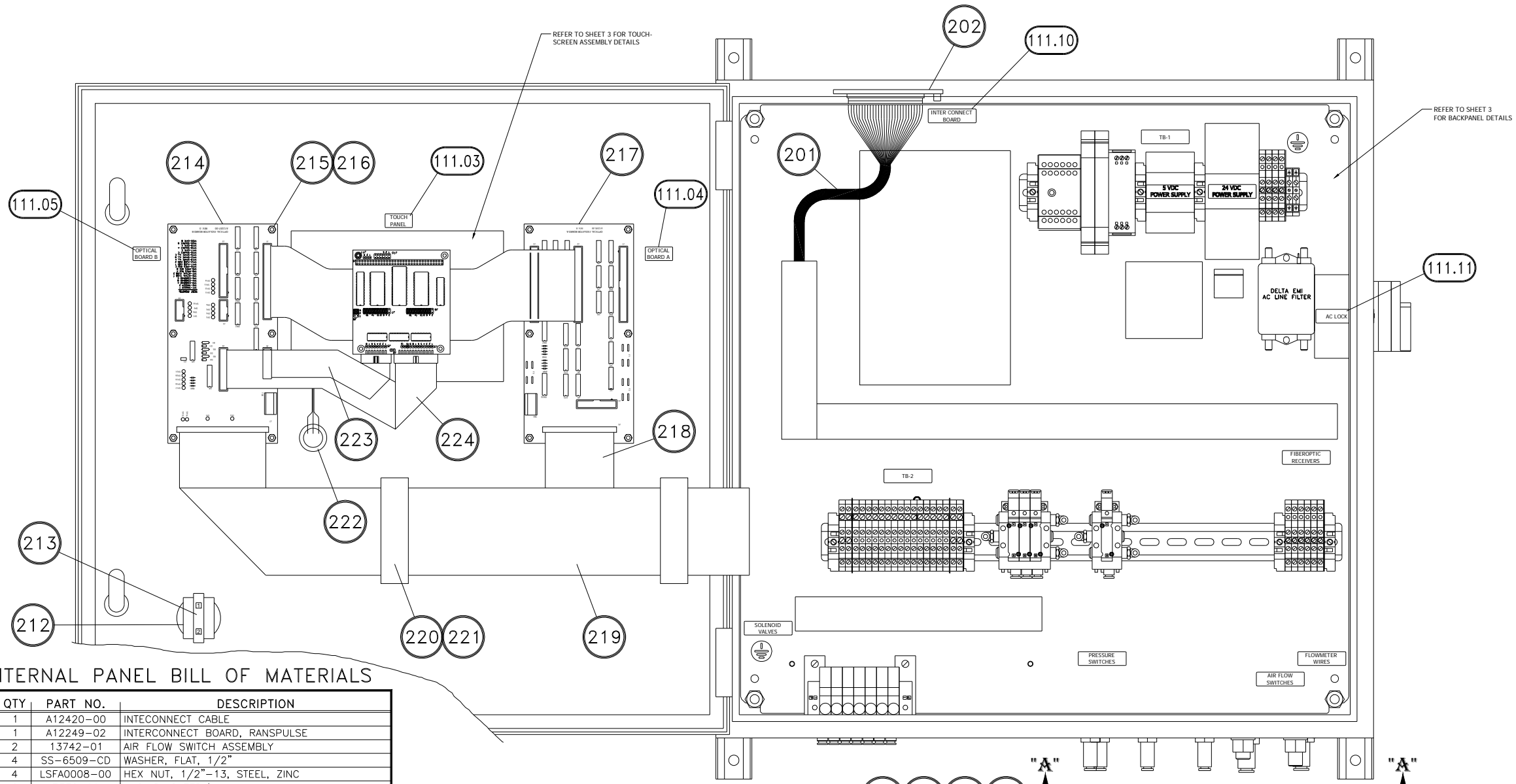

INTERNAL PANEL BILL OF MATERIALS

Item	QTY	PART NO.	DESCRIPTION
201	1	A12420-00	INTERCONNECT CABLE
202	1	A12249-02	INTERCONNECT BOARD, RANSPULSE
203	2	13742-01	AIR FLOW SWITCH ASSEMBLY
204	4	SS-6509-CD	WASHER, FLAT, 1/2"
205	4	LSFA0008-00	HEX NUT, 1/2"-13, STEEL, ZINC
206	8	7332-00	LUG, RING TERMINAL
207	B1	A11004-00	WIRING HARNESS, FLOWMETER
208	2	41-FBH-1001	BULKHEAD UNION, 3/8" ODT
209	A1	A13354-00	BULKHEAD UNION, BRASS, 5/32" (4mm) ODT
210	F1	A13356-00	FITTING, BULKHEAD, 5/32"ODT x 1/8"NPT(F)
211	F1	25766-106	PRESSURE SWITCH, 1/8" NPT(M)
212	1	LSME0004-00	CLIP WITH LOCKING LEVER
213	1	LSME0006-00	CONTACT MODULE, NORMALLY CLOSED
214	1	A12207-01	OPTICAL ISOLATOR BOARD B, RANSPULSE
215	12	73106-05	SPACER, NYLON, 1/4" ODT x 1/4" LONG
216	12	SSF-8147-ZN	NUT, ELASTIC STOP, #4-40, STEEL
217	1	A12205-01	OPTICAL ISOLATOR BOARD A, RANSPULSE
218	1	A12371-44.0	50 CONDUCTOR RIBBON CABLE ASSY, (44" L.)
219	1	A12372-56.0	64 CONDUCTOR RIBBON CABLE ASSY, (56" L.)
220	4	77400-00	CABLE MOUNT, 3"
221	2	A12415-00	ADHESIVE, HIGH STRENGTH, 3M-90
222	1	A13355-00	USB BULKHEAD, TYPE A, FEMALE
223	1	A12367-9.0	16 CONDUCTOR RIBBON CABLE ASSY, (9" L.)
224	1	A12369-12	26 CONDUCTOR RIBBON CABLE ASSY, (12" L.)

IF ITEM A IN PART NUMBER=1, A1=1, IF ITEM A IN PART NUMBER=2, A1=3,  
 IF ITEM B IN PART NUMBER=2, B1=2, IF ITEM B IN PART NUMBER=3, B1=3,  
 IF ITEM F IN PART NUMBER=1, F1=0, IF ITEM F IN PART NUMBER=1, F1=2.

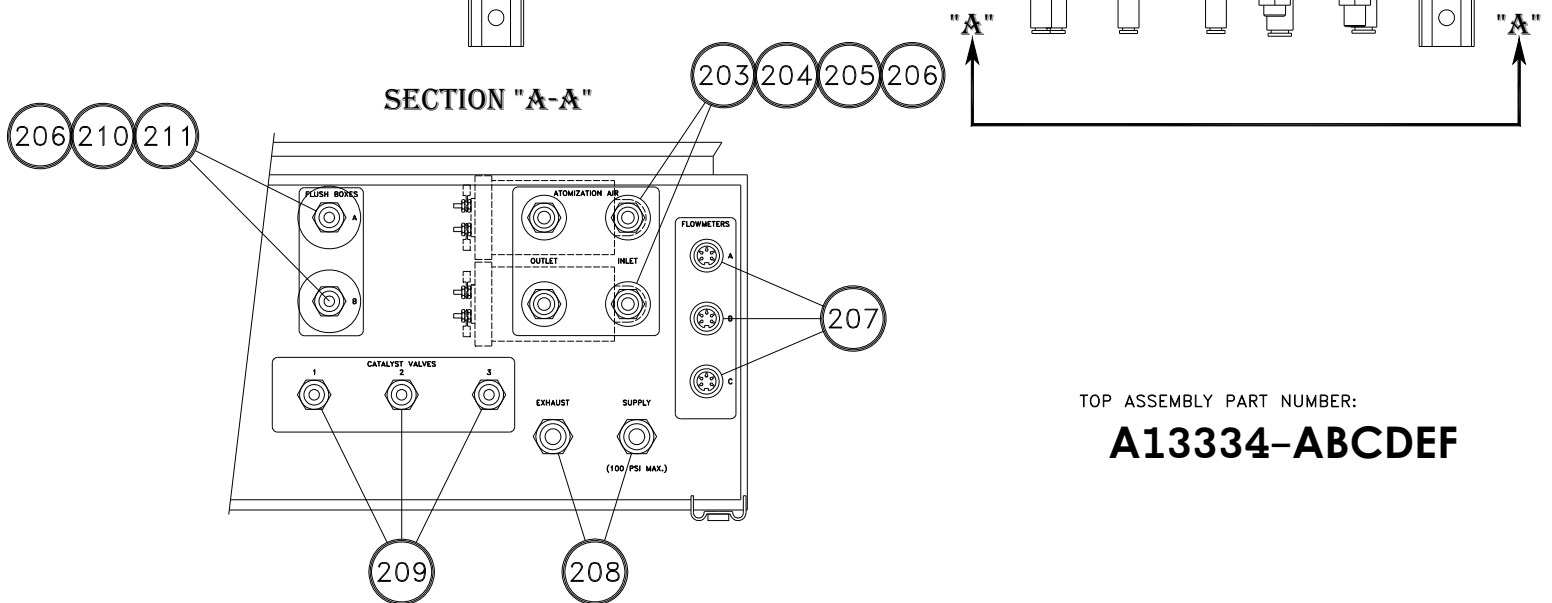

TOP ASSEMBLY PART NUMBER:  
**A13334-ABCDEF**

RansPulse Control Panel Sheet 2

## TOUCHPANEL ASSEMBLY DETAILS

### TOUCHPANEL SUBASSEMBLY BILL OF MATERIALS

Item	QTY	PART NO.	DESCRIPTION
301	1	A132162-01	TOUCHSCREEN, WINSYSTEMS
302	1	A12356-02	PC BOARD, DIGITAL I/O, PC104 INTERFACE
303	1	A12358-01	PC BOARD, HIGH SPEED COUNTER, PC104
304	4	7714-08C	SCREW, #4-40 x 1/4" L, SLOTTED
305	8	A12362-00	STANDOFF, #4-40, 0.625 L, HEX
306	1	A13333-00	SPECIAL RIBBON CABLE ASSY. FOR RANSPULSE
307	1	A13166-00	RIBBON CABLE ASSY, WINSYSTEMS SERIAL

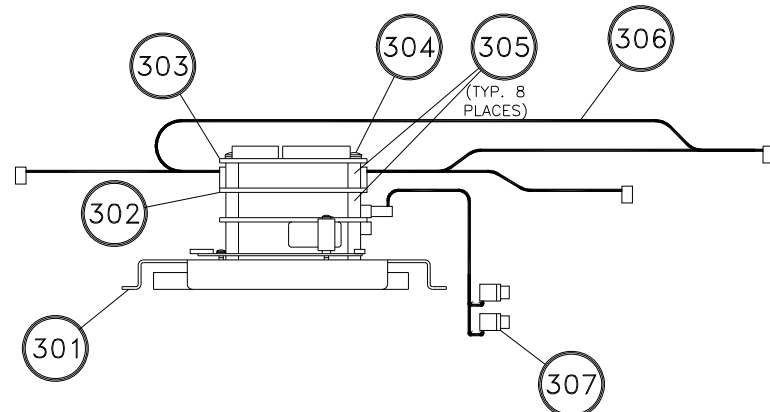

### BACKPANEL ASSY. BILL OF MATERIALS

Item	QTY	PART NO.	DESCRIPTION
320	1	A12424-00	BACK PANEL DETAILS, RANSFLOW
321	1	A12463-00	LABEL, WIRING DIAGRAM, RANSFLOW
322	6	SSF-4034-ZN	SCREW, #10-32, SLOTTED, PAN HEAD, ZINC
323	6	7734-04	LOCKWASHER, #10, SPLIT
324	4	7486-15	WASHER, FLAT, #10, STEEL
325	1	A13226-00	AC LINE FILTER
326	2	SSF-4034-ZN	SCREW, #10-32, SLOTTED
327	2	7734-04	LOCKWASHER, #10, SPLIT
328	8	20827-00	CLIP, CABLE
329	34.5"	TR-SSEM-183	WIRE DUCT, 1" WIDE x 3" HIGH, WHITE
330	34.5"	TR-SSEM-184	WIRE DUCT COVER, 1" WIDE, WHITE
331	34.5"	LSMM0051-00	DOUBLE SIDED TAPE
332	2	7703-44C	SCREW, MACHINE, FLAT HEAD, SS, #8-32
333	2	7734-03	LOCKWASHER, HELICAL SPRING, #8
334	2	7733-06	NUT, HEX, #8-32
335	A1	A12359-00	SOLENOID VALVE, 24VDC
336	1	A2	A3
337	2	A12418-00	SOLENOID VALVE STACK MOUNTING PLATE

### WIRING, TUBING, & ACCESSORIES (Not pictured) (WIRE PER SCHEMATIC A13362-00)

350	30'	76504-10	WIRE, BLK, 18 GA.
351	30'	78210-18	WIRE, BLU W/WHT, 18 GA.
352	6'	3800-03	WIRE, GRN/YEL, 18 GA.
353	30'	6655-13	WIRE, BLU, 22 GA.
354	30'	78210-22	WIRE, BLU W/WHT, 22 GA.
355	60	72591-01	SLEEVE, CABLE
356	10	72591-04	SLEEVE, CABLE
357	12	80148-16	SLEEVE, DOUBLE, CABLE
358	5	80148-18	SLEEVE, DOUBLE, CABLE
359	4'	9704-18	TUBING, 5/32" O.D.
360	4'	9704-03	TUBING, 1/4" O.D.
361	1	41-FTP-1002	FITTING, UNION-T, 5/32" ODT
362	200	A13390-00	LABELS, PRINTER, WIRE

IF ITEM A IN PART NUMBER=1, A1=7, A2=A13359-07, AND A3=7 POS. MANIFOLD BLOCK  
IF ITEM A IN PART NUMBER=2, A1=16, A2=A13359-16, & A3=16 POS. MANIFOLD BLOCK

## BACKPANEL ASSEMBLY DETAILS

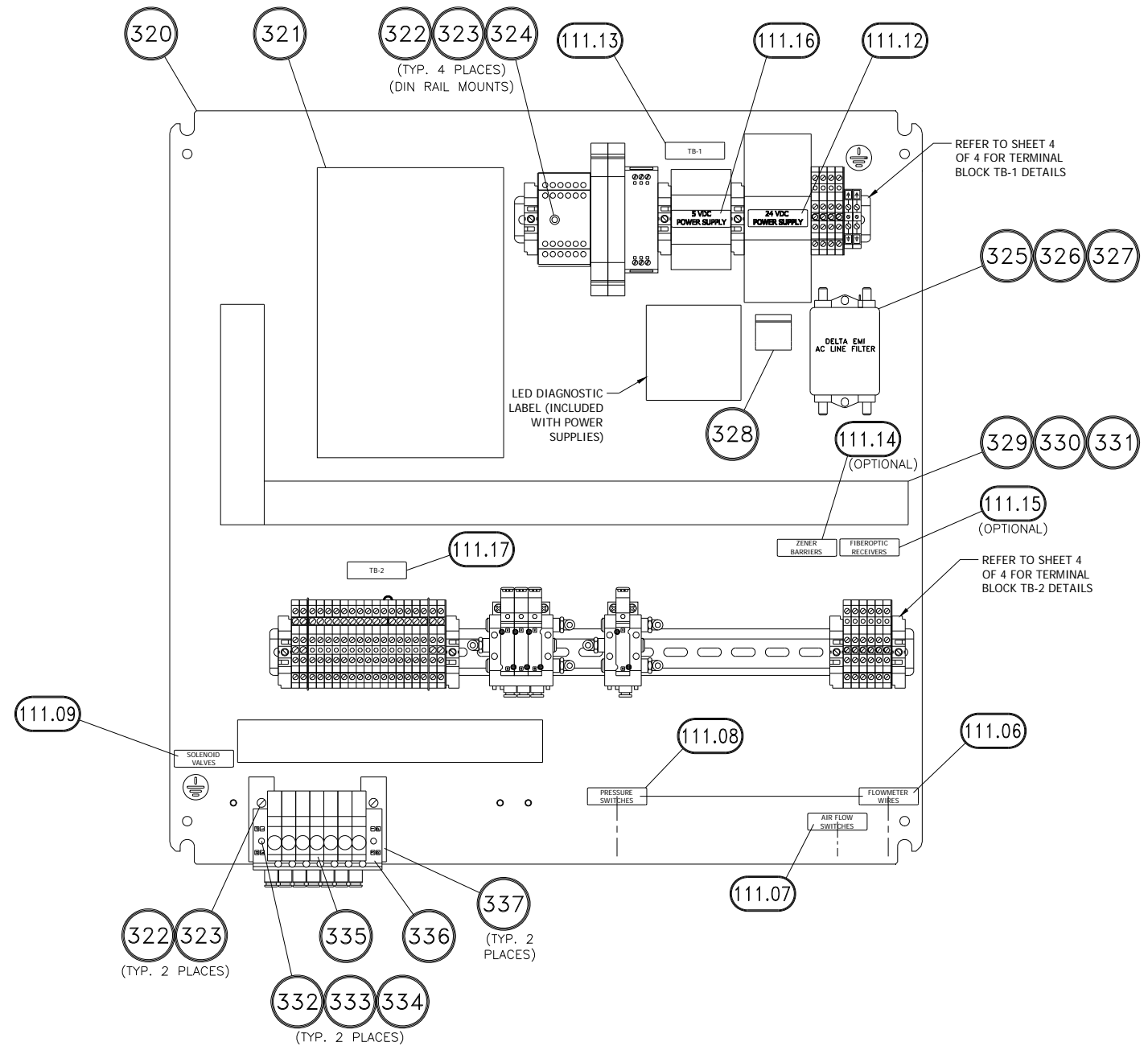

TOP ASSEMBLY PART NUMBER:

**A13334-ABCDEF**

TB-1 ASSEMBLY DETAILS

TB-1 BILL OF MATERIALS

Item	QUANTITIES		PART NO.	DESCRIPTION
	D=0	D=1		
401	10.5"	10.5"	LS0079-00	DIN RAIL
402	2	3	TR-SSEH-382	TERMINAL BLOCK END CLAMP
403	0	1	73837-11	ZENER DIODE BARRIER, HIGH CURRENT
404	0	2	73837-10	2-CHANNEL AC SAFESNAP BARRIER
405	0	1	A12610-00	CONVERTER, 24VDC TO 15VDC
406	1	1	A12417-00	POWER SUPPLY, 5VDC @ 5 AMP
407	1	1	A12416-00	POWER SUPPLY, 24VDC @ 5 AMP
408	4	4	TR-SSEH-497	DOUBLE HIGH TERMINAL BLOCK (6mm)
409	4	4	TR-SSEH-499	VERTICAL INTERCONNECT FOR D.H. TERM. BLOCK
410	4	4	TR-SSEH-385	BLANK LABELS FOR ENTRELEC TERMINAL BLOCKS
411	1	1	TR-SSEH-500	DOUBLE HIGH TERMINAL BLOCK END CAP
412	2	2	TR-SSEH-417	GROUND BLOCK TERMINAL

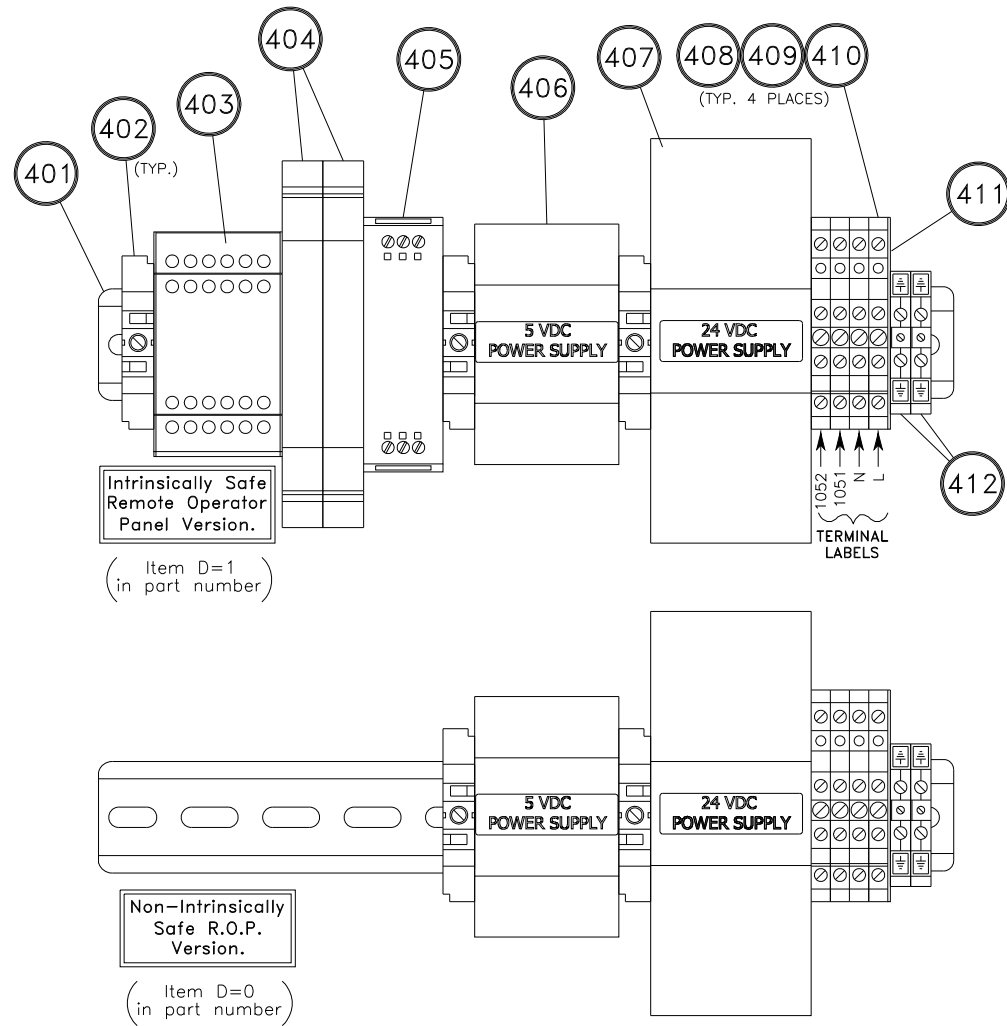

TB-2 ASSEMBLY DETAILS

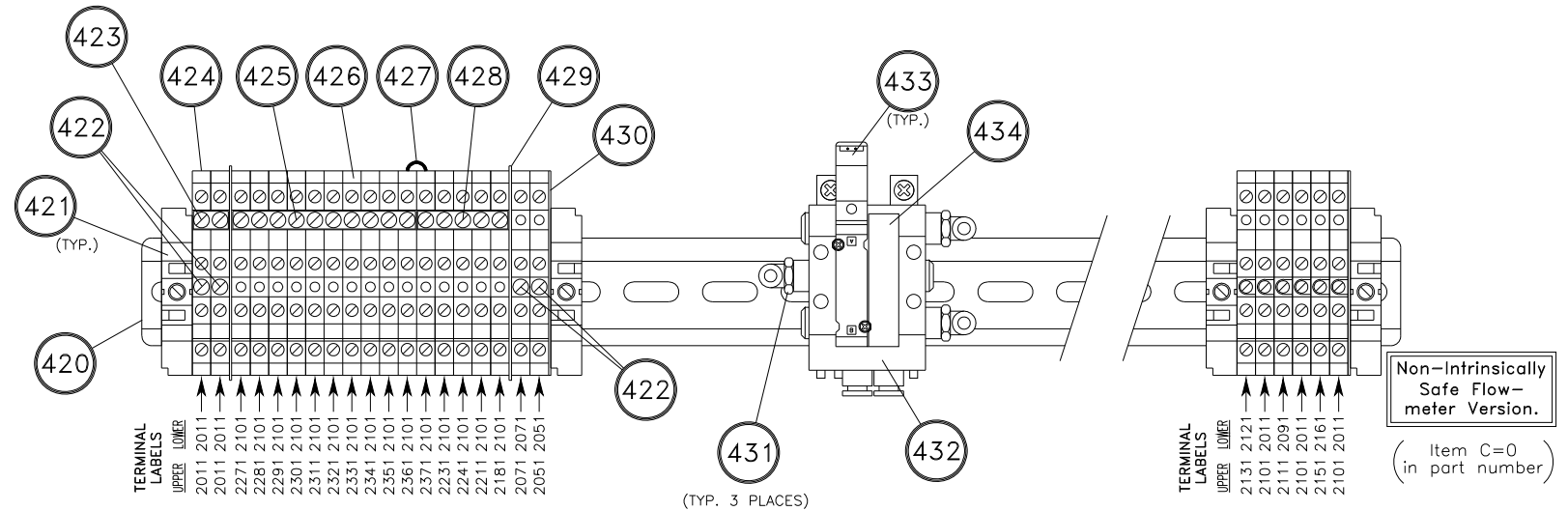

TB-2 BILL OF MATERIALS

Item	QTY	PART NO.	DESCRIPTION
420	19"	LS0079-00	DIN RAIL
421	4	TR-SSEH-382	TERMINAL BLOCK END CLAMP
422	4	TR-SSEH-499	VERTICAL INTERCONNECT FOR D.H. TERM. BLOCK
423	1	TR-SSEH-541	JUMPER ASSEMBLY, 2-POLE
424	C1	TR-SSEH-497	DOUBLE HIGH TERMINAL BLOCK (6mm)
425	1	TR-SSEH-498	10 POSITION JUMPER BAR
426	2	TR-SSEH-385	BLANK LABELS FOR ENTRELEC TERMINAL BLOCKS
427	1.5"	6655-13	WIRE, 20 GA, DK. BLUE
428	1	TR-SSEH-501	JUMPER ASSY., 5-POLE
429	2	TR-SSEH-538	DOUBLE HIGH TERMINAL BLOCK SEP. END SECT.
430	C2	TR-SSEH-500	DOUBLE HIGH TERMINAL BLOCK END CAP
431	3	SSP-6427	FITTING, ELBOW, 1/4" ODT x 1/8" NPT(M)
432	AB1	A13358-02	2-POSITION SOLENOID VALVE MANIFOLD
	AB2	A13358-03	3-POSITION SOLENOID VALVE MANIFOLD
	AB3	A13358-04	4-POSITION SOLENOID VALVE MANIFOLD
433	AB4	A13357-00	DOUBLE ACTING SOLENOID VALVE
434	AB5	A13360-00	BLANKING PLATE, SOLENOID VALVE MANIFOLD
435	BC1	73837-08	ZENER BARRIER, 2-CHANNEL, 24 VDC
436	BC2	A12720-00	FIBEROPTIC RECEIVER MODULE

- C1: IF ITEM C=0 IN PART NUMBER, C1=25, OTHERWISE, C1=19.
- C2: IF ITEM C=0 IN PART NUMBER, C2=2, OTHERWISE, C2=1.
- AB1: IF ITEM A=1 IN PART NUMBER, AB1=1, OTHERWISE AB1=0.
- AB2: IF ITEM A=2 & B=2 IN PART NUMBER, AB2=1, OTHERWISE, AB2=0.
- AB3: IF ITEM A=2 & B=3 IN PART NUMBER, AB3=1, OTHERWISE, AB3=0.
- AB4: IF ITEM A=1 & B=2 IN PART NUMBER, AB4=1.  
IF ITEM A=1 & B=3 IN PART NUMBER, AB4=2.  
IF ITEM A=2 & B=2 IN PART NUMBER, AB4=3.  
IF ITEM A=2 & B=3 IN PART NUMBER, AB4=4.
- AB5: IF ITEM A=1 & B=2 IN PART NUMBER, AB5=1, OTHERWISE, AB5=0.
- BC1: IF ITEM B=2 & C=0 IN PART NUMBER, BC1=0,  
IF ITEM B=2 & C=1 IN PART NUMBER, BC1=2,  
IF ITEM B=2 & C=2 IN PART NUMBER, BC1=0,  
IF ITEM B=3 & C=0 IN PART NUMBER, BC1=0,  
IF ITEM B=3 & C=1 IN PART NUMBER, BC1=3,  
IF ITEM B=3 & C=2 IN PART NUMBER, BC1=0.
- BC2: IF ITEM B=2 & C=0 IN PART NUMBER, BC1=0,  
IF ITEM B=2 & C=1 IN PART NUMBER, BC1=0,  
IF ITEM B=2 & C=2 IN PART NUMBER, BC1=2,  
IF ITEM B=3 & C=0 IN PART NUMBER, BC1=0,  
IF ITEM B=3 & C=1 IN PART NUMBER, BC1=0,  
IF ITEM B=3 & C=2 IN PART NUMBER, BC1=3.

TOP ASSEMBLY PART NUMBER:  
**A13334-ABCDEF**

# RansPulse Schematics

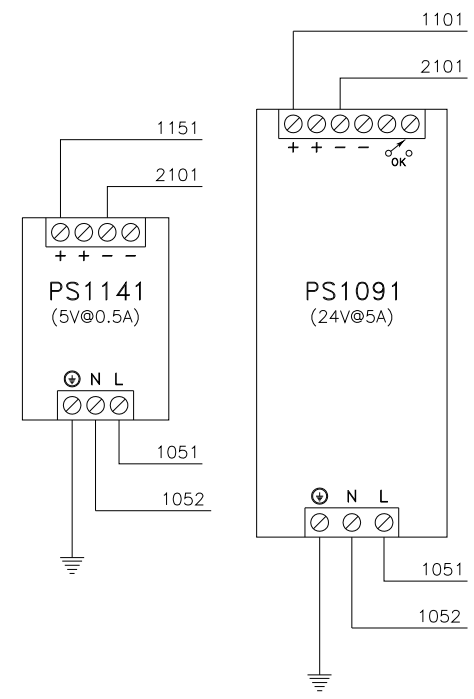
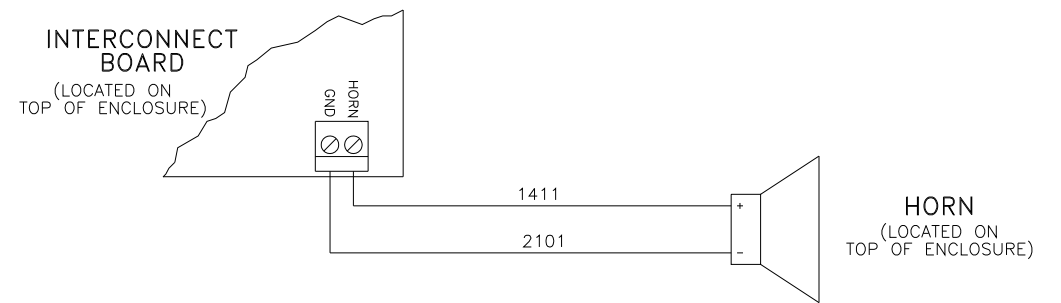
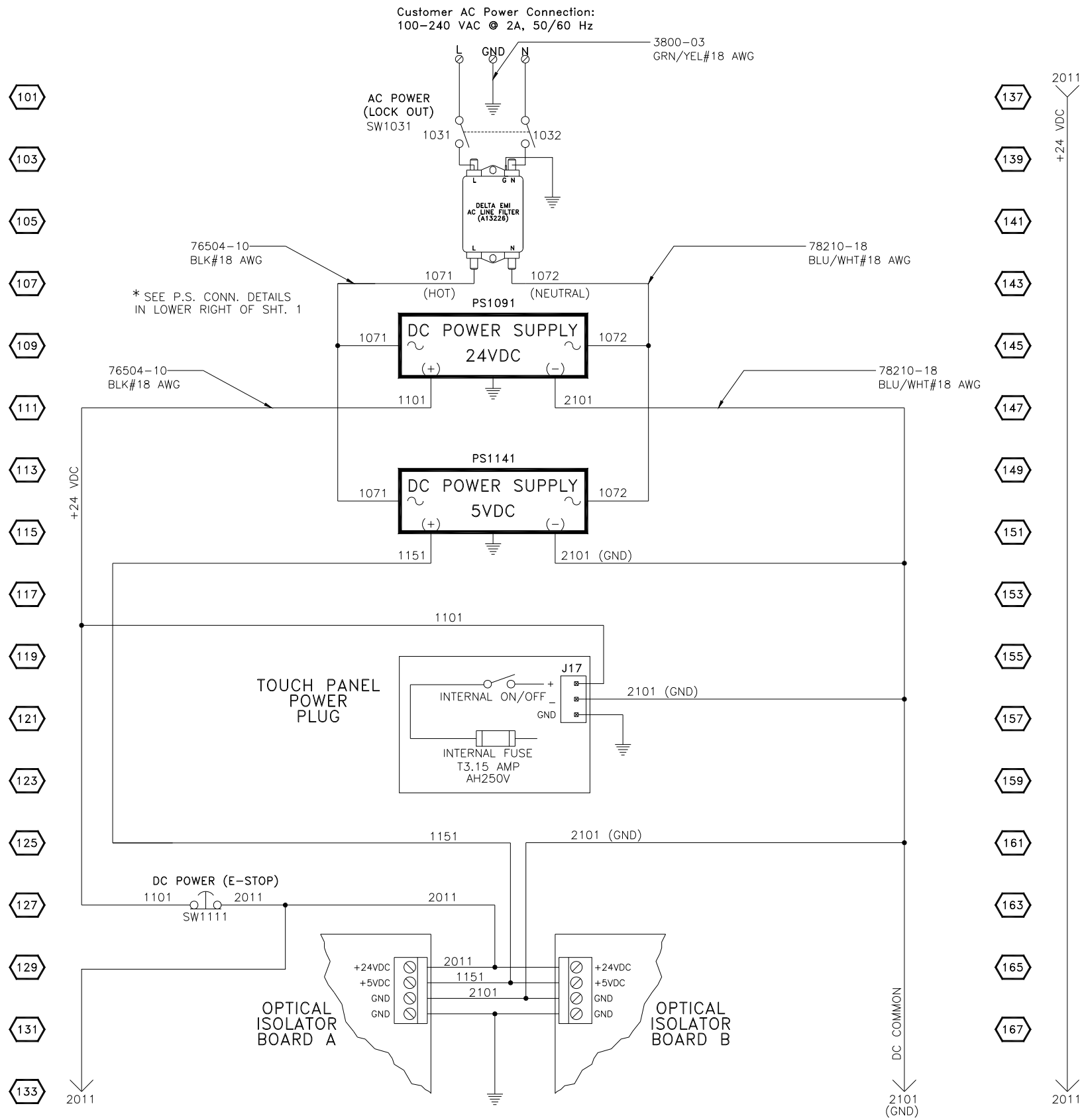

RansPulse Wiring Diagram Sheet 1

NOTE: USE THIS SHEET ONLY IF NON-FIBEROPTIC FLOWMETERS ARE USED!

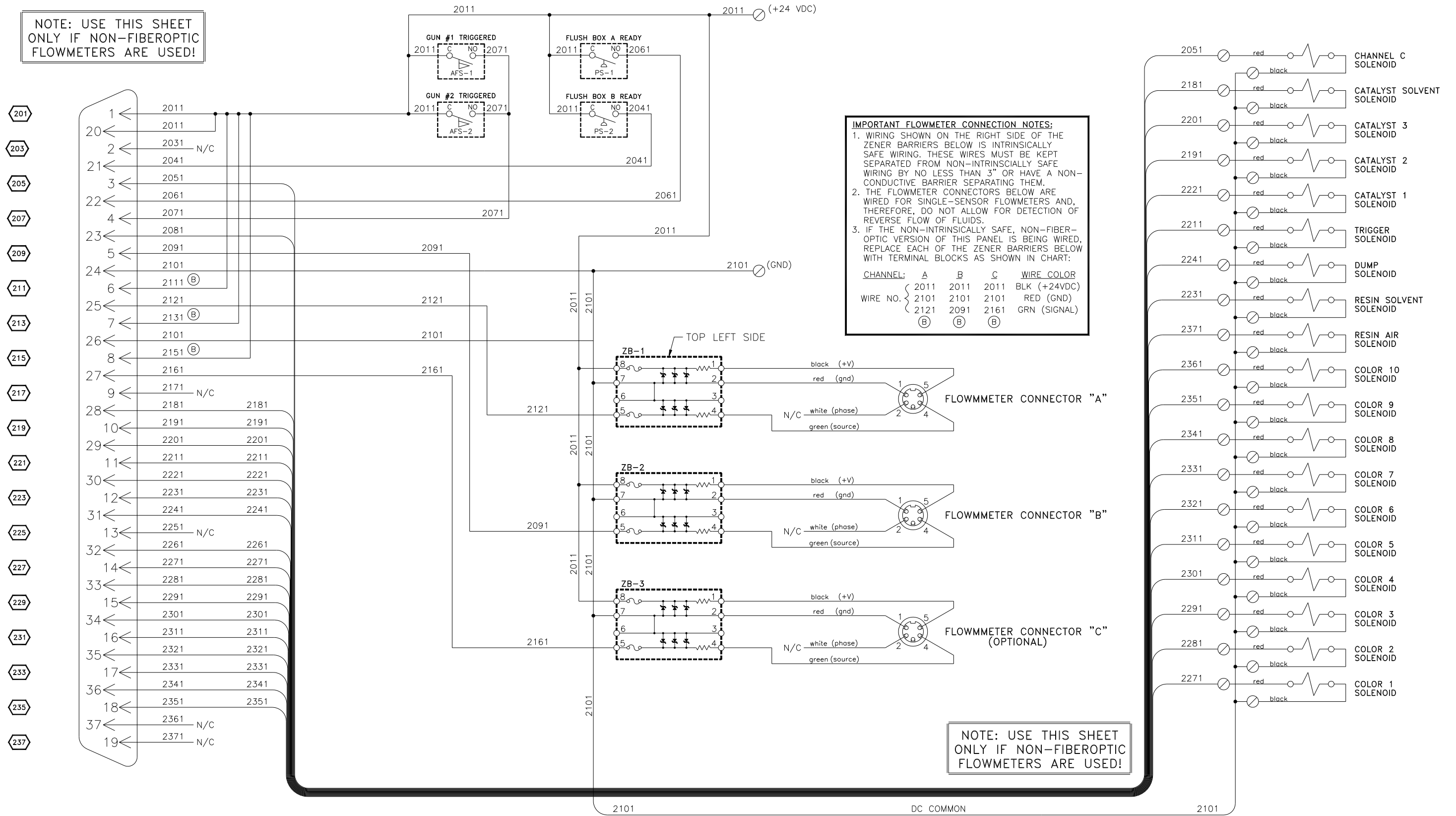

RansPulse Wiring Diagram Sheet 2



NOTE: USE THIS SHEET ONLY IF FIBEROPTIC FLOWMETERS ARE USED!

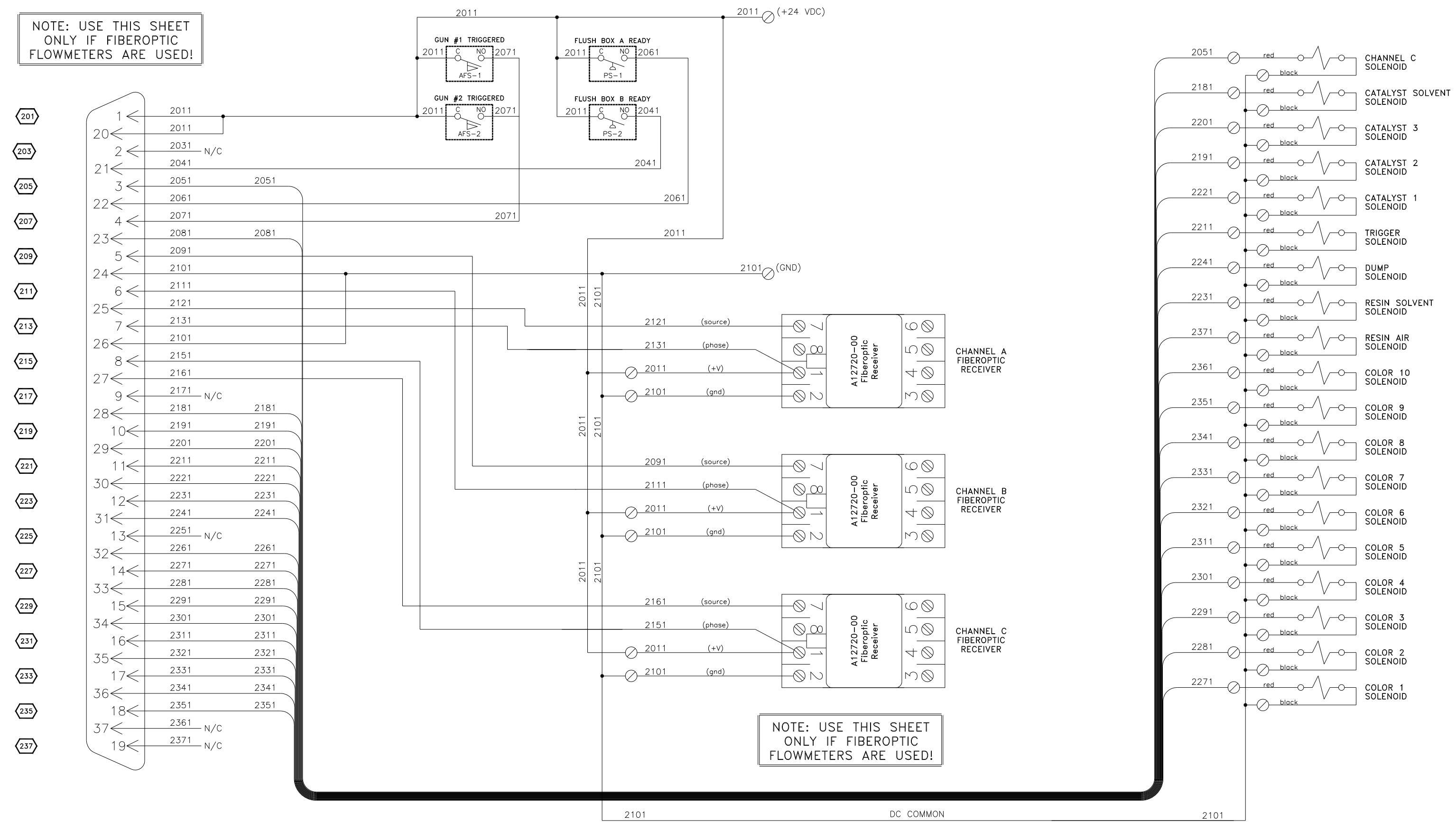

NOTE: USE THIS SHEET ONLY IF FIBEROPTIC FLOWMETERS ARE USED!

RansPulse Wiring Diagram Sheet 3

**NOTE:**  
 WIRING AND ZENERS SHOWN BELOW ARE OPTIONAL  
 AND ONLY REQUIRED IF THE INTRINSICALLY SAFE  
 VERSION OF THE REMOTE OPERATOR PANEL IS  
 ORDERED. REFER TO DRAWING: A13334 FOR DETAILS.

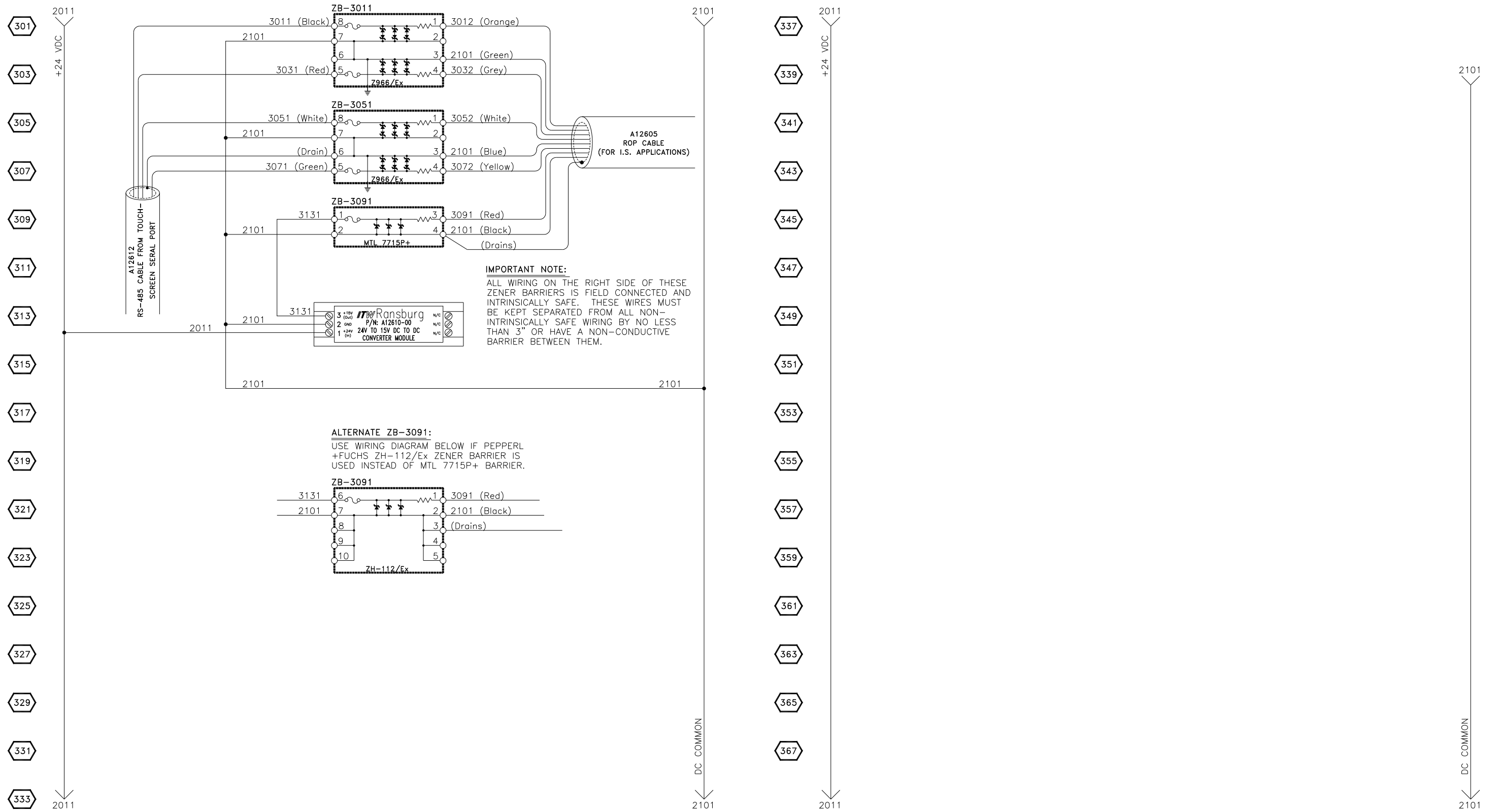

**IMPORTANT NOTE:**  
 ALL WIRING ON THE RIGHT SIDE OF THESE  
 ZENER BARRIERS IS FIELD CONNECTED AND  
 INTRINSICALLY SAFE. THESE WIRES MUST  
 BE KEPT SEPARATED FROM ALL NON-  
 INTRINSICALLY SAFE WIRING BY NO LESS  
 THAN 3" OR HAVE A NON-CONDUCTIVE  
 BARRIER BETWEEN THEM.

**ALTERNATE ZB-3091:**  
 USE WIRING DIAGRAM BELOW IF PEPPERL  
 +FUCHS ZH-112/Ex ZENER BARRIER IS  
 USED INSTEAD OF MTL 7715P+ BARRIER.

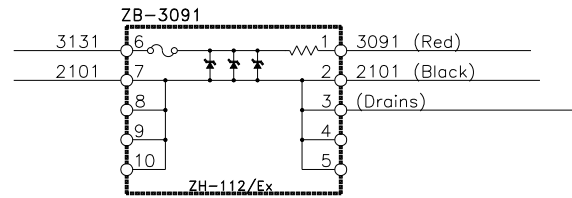

### RansPulse Wiring Diagram Sheet 4

# General Schematics

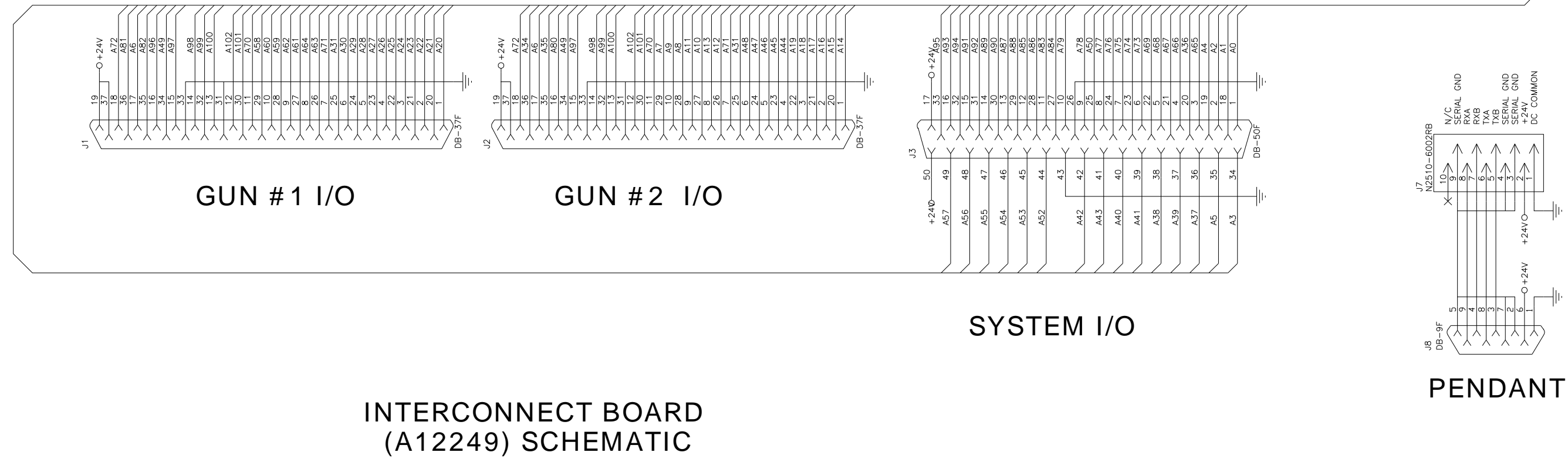

INTERCONNECT BOARD (A12249) SCHEMATIC

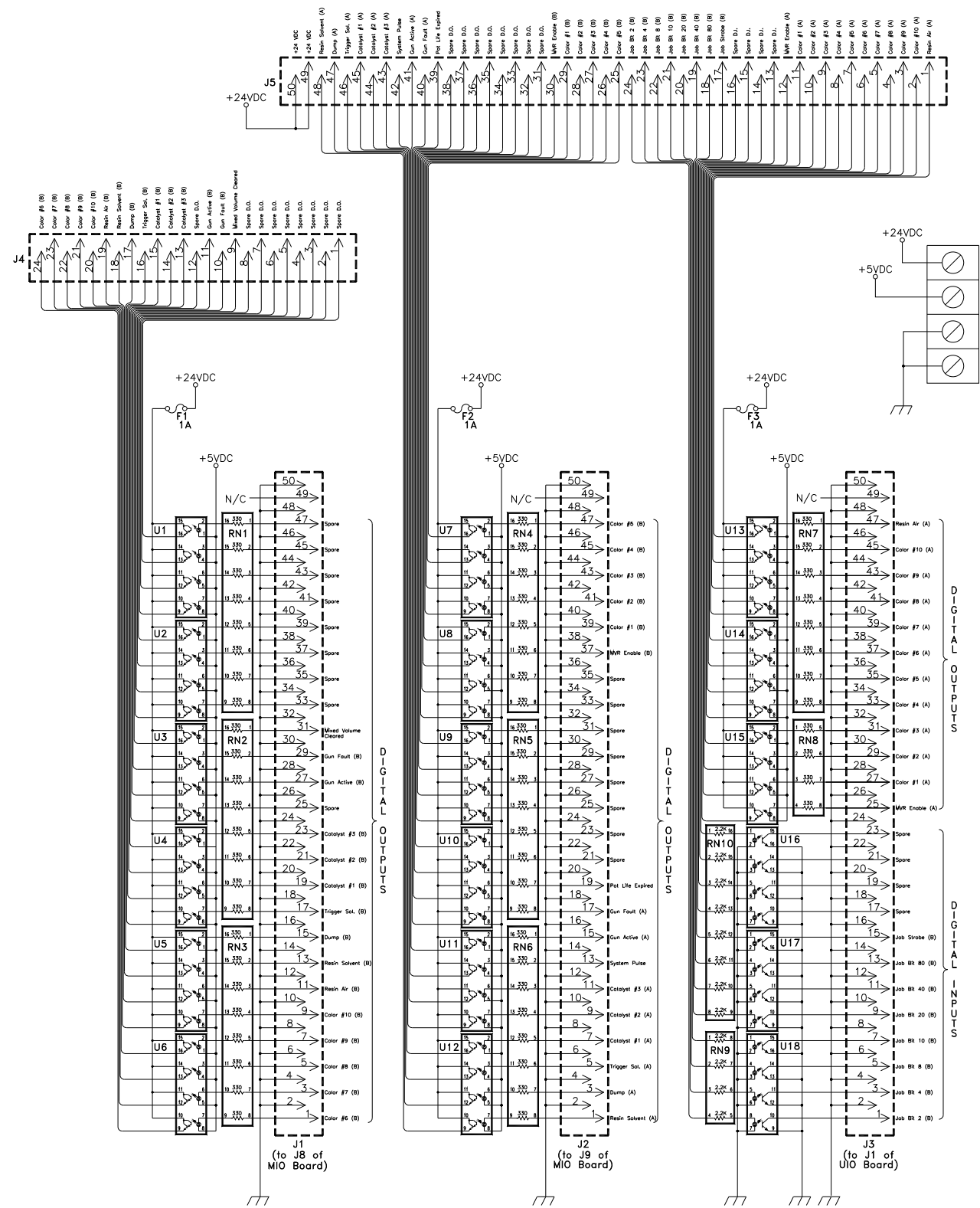

Optical Isolator Board Schematic - A

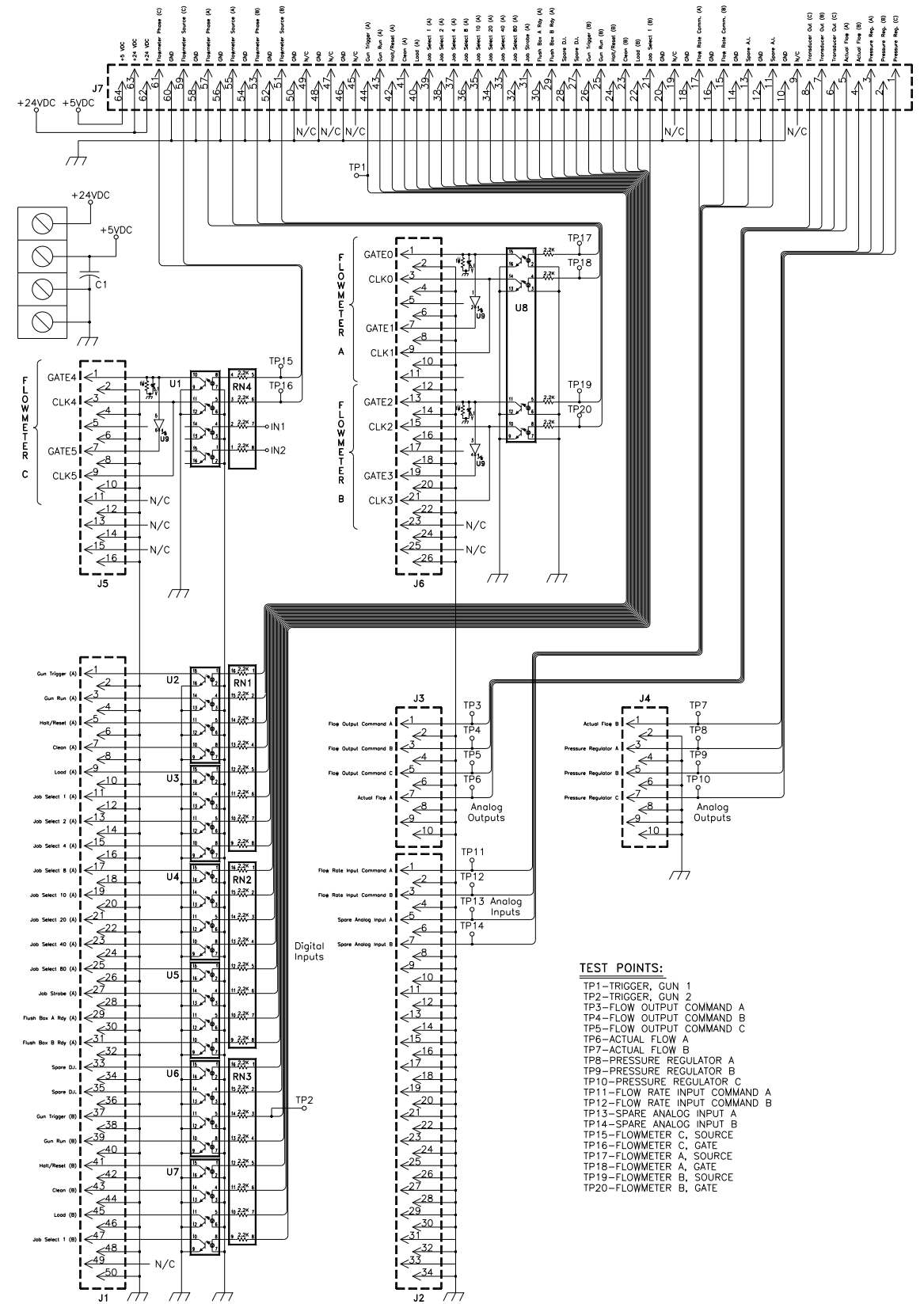

Optical Isolator Board Schematic - B

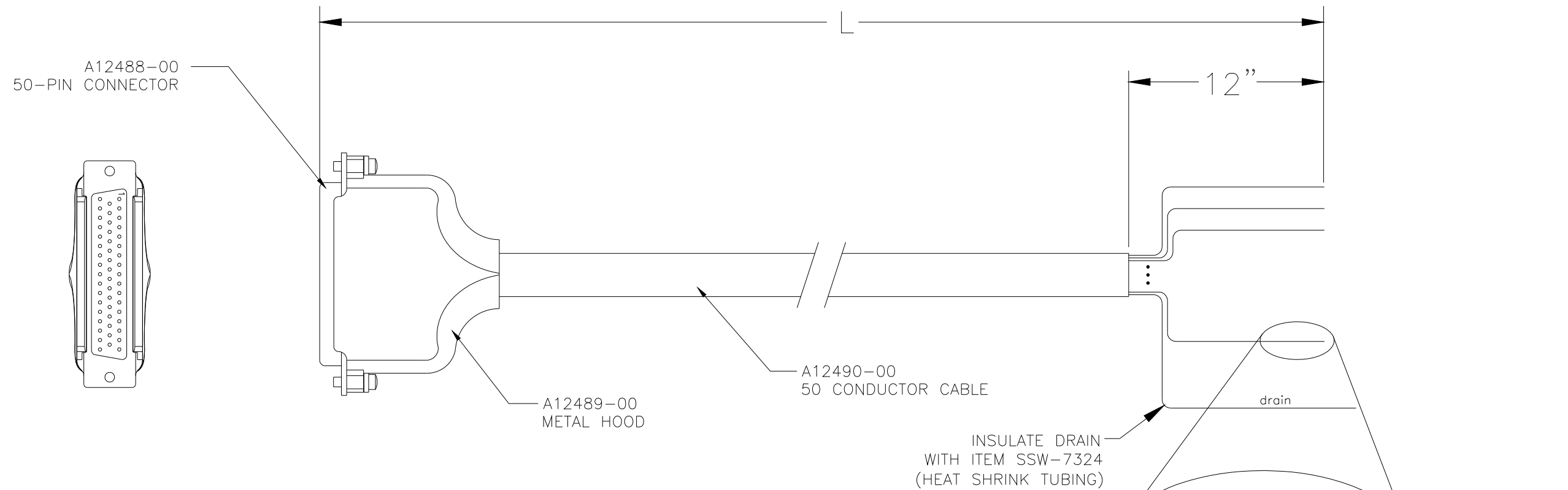

WIRE TABLE

PIN	WIRE COLOR	PIN	WIRE COLOR	PIN	WIRE COLOR
1	BLACK	20	RED/GREEN STRIPE	39	WHITE/BLACK/GREEN
2	WHITE	21	ORANGE/GREEN STRIPE	40	RED/WHITE/GREEN
3	RED	22	BLACK/WHITE/RED	41	GREEN/WHITE/BLUE
4	GREEN	23	WHITE/BLACK/RED	42	ORANGE/RED/GREEN
5	ORANGE	24	RED/BLACK/WHITE	43	BLUE/RED/GREEN
6	BLUE	25	GREEN/BLACK/WHITE	44	BLACK/WHITE/BLUE
7	WHITE/BLACK STRIPE	26	ORANGE/BLACK/WHITE	45	WHITE/BLACK/BLUE
8	RED/BLACK STRIPE	27	BLUE/BLACK/WHITE	46	RED/WHITE/BLUE
9	GREEN/BLACK STRIPE	28	BLACK/RED/GREEN	47	GREEN/ORANGE/RED
10	ORANGE/BLACK STRIPE	29	WHITE/RED/GREEN	48	ORANGE/RED/BLUE
11	BLUE/BLACK STRIPE	30	RED/BLACK/GREEN	49	BLUE/RED/ORANGE
12	BLACK/WHITE STRIPE	31	GREEN/BLACK/ORANGE	50	BLACK/ORANGE/RED
13	RED/WHITE STRIPE	32	ORANGE/BLACK/GREEN		
14	GREEN/WHITE STRIPE	33	BLUE/WHITE/ORANGE		
15	BLUE/WHITE STRIPE	34	BLACK/WHITE/ORANGE		
16	BLACK/RED STRIPE	35	WHITE/RED/ORANGE		
17	WHITE/RED STRIPE	36	ORANGE/WHITE/BLUE		
18	ORANGE/RED STRIPE	37	WHITE/RED/BLUE		
19	BLUE/RED STRIPE	38	BLACK/WHITE/GREEN		

NOTE: CUT DRAIN OFF AT EDGE OF OUTER CABLE JACKET, INSIDE OF HOOD.

STANDARD\* STOCKED LENGTHS

-L	CABLE LENGTH (FT.)
10	10'-0"
25	25'-0"
50	50'-0"
75	75'-0"
100	100'-0"

\*NOTE: OTHER LENGTHS LESS THAN 100' AVAILABLE UPON SPECIAL REQUEST. LENGTHS LONGER THAN 100' ONLY WITH APPROVAL OF R&D.

**50 - Conductor System  
I/O Cable  
Part # A12487**

# RansFlow Spare Parts

Recommended Quantity						
Based on the number of installed units of:						
Item	Part Number	Description	1	2	4	8
Main Control Enclosure:						
	A12768-XX	Cable, Fiber Optic	0	1	1	1
	A12473-00	Stylus, 24" Tether	1	2	2	4
4	13742-01	Air Flow Switch Assembly	1	1	2	4
23	25766-106	Pressure Switch Assembly	1	1	2	4
37	73837-08	Zener Barrier	1	1	2	2
38	78643-00	E/P Transducer, High Speed	1	2	2	4
39	SSM-5504	Air Filter	1	2	2	4
43	A12416-00	Power Supply 24V @ 5A	0	1	1	1
46	A12359-00	Solenoid Valve, 24V, Manifold Mount	2	4	4	8
51	A12417-00	Power Supply 5V @ 5A	0	1	1	1
79	A12356-02	Digital I/O Module, PC 104	1	1	1	2
80	A12357-02	Analog & Digital I/O Module, PC 104	1	1	1	2
81	A12358-01	High Speed Counter Module, PC 104	1	1	1	2
85	A12205-00	Optical Isolator Board A	0	0	1	1
86	A12207-00	Optical Isolator Board B	0	0	1	1
99	77384-00	Switch Operator, Red, Mushroom Hd.	1	1	2	2
100	LSME0004-00	Clip for Switch Operator with Lock	1	1	2	2
101	LSME0006-00	Contact Module, N.C.	1	1	2	2
187	A12720-00	Receiver, Fiber Optic	0	1	1	1
190	A13162-01	Touch Panel, 6.4" Display, PC 104	0	1	1	1

Reference Page # 12 for Item Number(s)

Recommended Quantity						
Based on the number of installed units of:						
Item	Part Number	Description	1	2	4	8
Fluid Panel: (Note: Not all parts below are used on every fluid panel.)						
6	LSMM0056-00	Spiral Mix Element (Low Pressure)	5	10	20	20
	LSMM0056-01	Spiral Mix Element (High Pressure)	5	10	20	20
9	76805-01	ZHM-02 Flowmeter	1	1	1	2
	77214-00	Fiberoptic RF-1 Flowmeter	1	1	1	2
	A13296-00	Piston Flowmeter	1	1	1	2
	A12712-00	Flowmeter	1	1	1	2
12	78014-01	Flushable Mix Block Assembly	0	0	1	1
	78014-02	Non-Flushable Mix Block Assembly	0	0	1	1
	LBAL0016-00	High Pressure Mix Block	0	0	1	1
21	76624-02	Low Flow, Weepless MVR Valve	1	1	2	2
	76624-03	Medium Flow, Weepless MVR Valve	1	1	2	2
	76624-04	High Flow, Weepless MVR Valve	1	1	2	2
	78137-02	Low Flow, Weep Style MVR Valve	1	1	2	2
	78137-03	Medium Flow, Weep Style MVR Valve	1	1	2	2
	78137-04	High Flow, Weep Style MVR Valve	1	1	2	2
28	LSMM0059-01	Calibration Tube	2	2	4	8
29	LS0067	3-Way Ball Valve for Low Pressure	0	0	1	2
	75774-00	3-Way Ball Valve for High Pressure	0	0	1	2
34	75773-00	High Pressure Check Valve Assy.	1	1	2	4
35	76093-00	Needle Valve	0	0	2	2
51	A10610-00	MVR Trigger Valve Kit	0	0	1	2

Reference Page # 6 for Item Number(s)

## RansFlow Spare Parts



# **RansPulse Spare Parts**

Recommended Quantity						
Based on the number of installed units of:						
Item	Part Number	Description	<u>1</u>	<u>2</u>	<u>4</u>	<u>8</u>
Main Control Enclosure:						
	A12768-XX	Cable, Fiber Optic	0	1	1	1
	A12473-00	Stylus, 24" Tether	1	2	2	4
105	77384-00	Switch Operator, Red, Mushroom Hd.	1	1	2	2
203	13742-01	Air Flow Switch Assembly	1	1	2	4
211	25766-106	Pressure Switch Assembly	1	1	2	4
212	LSME0004-00	Clip for Switch Operator with Lock	1	1	2	2
213	LSME0006-00	Contact Module, N.C.	1	1	2	2
214	A12207-01	Optical Isolator Board B	0	0	1	1
217	A12205-01	Optical Isolator Board A	0	0	1	1
301	A13162-01	Touch Panel, 6.4" Display, PC 104	0	1	1	1
302	A12356-02	Digital I/O Module, PC 104	1	1	1	2
303	A12358-01	High Speed Counter Module, PC 104	1	1	1	2
335	A12359-00	Solenoid Valve, 24V, Manifold Mount	2	4	4	8
406	A12417-00	Power Supply 5V @ 5A	0	1	1	1
407	A12416-00	Power Supply 24V @ 5A	0	1	1	1
435	73837-08	Zener Barrier	1	1	2	2
436	A12720-00	Receiver, Fiber Optic	0	1	1	1

Reference Page #'s 25-28 for Item Number(s)

**Product Manual Price: \$50.00 (U.S.)**

**Manufacturing**

1910 North Wayne Street

Angola, Indiana 46703-9100

Telephone: 260-665-8800

Fax: 260-665-8516

**Technical Service - Assistance**

320 Phillips Ave.

Toledo, Ohio 43612-1493

Telephone (toll free): 800-233-3366

Fax: 419-470-2233

**Technical Support Representatives can direct you to the appropriate telephone number for ordering spare parts.**

© 2014 Finishing Brands All rights reserved.

Models and specifications subject to change without notice.