

# RAIS<sup>®</sup> FLEX<sup>®</sup> APPLICATORS

By Ransburg



FOR IN-DIRECT CHARGE  
WATERBASED APPLICATORS



**MODEL: 80445 RXi**

**IMPORTANT:** Before using this equipment, carefully read SAFETY PRECAUTIONS, starting on page 1, and all instructions in this manual. Keep this Service Manual for future reference.

Service Manual Price: \$50.00 (U.S.)





**NOTE:** This manual has been changed from revision **AH-15-02** to revision **AH-15-02.1**. Reasons for this change are noted under "Manual Change Summary" on page 62 of this manual.



	PAGE
<b>SAFETY:</b>	<b>1-5</b>
<a href="#">Safety Precautions</a> .....	1
<a href="#">Hazards / Safegaurds</a> .....	2
<b>ATEX/FM REQUIREMENTS:</b>	<b>6-9</b>
<a href="#">Ransflex RXI - Solvent Base Only</a> .....	7
<b>INTRODUCTION:</b>	<b>10-13</b>
<a href="#">General Description</a> .....	10
<a href="#">Ransflex New Features</a> .....	10
<a href="#">Specifications 80445 Ransflex Indirect Charge Waterbase</a> .....	11
<a href="#">Typical Installation</a> .....	13
<b>INSTALLATION:</b>	<b>14-15</b>
<a href="#">80445 Ransflex Indirect Charge Waterborne Installation</a> .....	14
<a href="#">General Installation Requirements</a> .....	14
<a href="#">Installation</a> .....	15
<b>OPERATION:</b>	<b>16-20</b>
<a href="#">Applicator Operation</a> .....	16
<a href="#">Flushing / Color Change Procedure</a> .....	18
<a href="#">Fluid Nozzle / Air Cap</a> .....	19
<a href="#">New Nozzle Design</a> .....	19
<a href="#">Air Cap / Nozzle Performance</a> .....	20
<b>MAINTENANCE:</b>	<b>21-34</b>
<a href="#">Suitable Solvents for Cleaning Ransflex Applicators</a> .....	21
<a href="#">Routine Schedule</a> .....	22
<a href="#">Troubleshooting Guide</a> .....	34
<b>PARTS IDENTIFICATION:</b>	<b>35-48</b>
<a href="#">Ransflex RXI Indirect Charge Waterbase</a> .....	35
<a href="#">Items for RXI (45KV) Unit</a> .....	39
<a href="#">Handle Components For All Models</a> .....	40
<a href="#">Accessories / Spare Parts Kits</a> .....	47
<a href="#">Recommended Spare Parts</a> .....	48
<b>WARRANTY POLICIES:</b>	<b>49</b>
<a href="#">Limited Warranty</a> .....	49



# SAFETY

## SAFETY PRECAUTIONS

Before operating, maintaining or servicing any Ransburg electrostatic coating system, read and understand all of the technical and safety literature for your Ransburg products. This manual contains information that is important for you to know and understand. This information relates to **USER SAFETY** and **PREVENTING EQUIPMENT PROBLEMS**. To help you recognize this information, we use the following symbols. Please pay particular attention to these sections.

**A WARNING!** states information to alert you to a situation that might cause serious injury if instructions are not followed.

**A CAUTION!** states information that tells how to prevent damage to equipment or how to avoid a situation that might cause minor injury.

**A NOTE** is information relevant to the procedure in progress.

While this manual lists standard specifications and service procedures, some minor deviations may be found between this literature and your equipment. Differences in local codes and plant requirements, material delivery requirements, etc., make such variations inevitable. Compare this manual with your system installation drawings and appropriate Ransburg equipment manuals to reconcile such differences.



Careful study and continued use of this manual will provide a better understanding of the equipment and process, resulting in more efficient operation, longer trouble-free service and faster, easier troubleshooting. If you do not have the manuals and safety literature for your Ransburg system, contact your local Ransburg representative or Ransburg.





### WARNING



- The user **MUST** read and be familiar with the Safety Section in this manual and the Ransburg safety literature therein identified.
- This manual **MUST** be read and thoroughly understood by **ALL** personnel who operate, clean or maintain this equipment! Special care should be taken to ensure that the **WARNINGS** and safety requirements for operating and servicing the equipment are followed. The user should be aware of and adhere to **ALL** local building and fire codes and ordinances as well as **NFPA-33 SAFETY STANDARD, LATEST EDITION**, prior to installing, operating, and/or servicing this equipment.



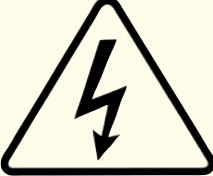

### WARNING

- The hazards shown on the following pages may occur during the normal use of this equipment. Please read the hazard chart beginning on [page 2](#).

<p><b>AREA</b> Tells where hazards may occur.</p>	<p><b>HAZARD</b> Tells what the hazard is.</p>	<p><b>SAFEGUARDS</b> Tells how to avoid the hazard.</p>
<p style="text-align: center;"><b>Spray Area</b></p> <div style="text-align: center;">  </div> <div style="text-align: right; margin-top: 20px;">  </div>	<p><b>Fire Hazard</b></p> <p>Improper or inadequate operation and maintenance procedures will cause a fire hazard.</p> <p>Protection against inadvertent arcing that is capable of causing fire or explosion is lost if any safety interlocks are disabled during operation. Frequent Power Supply or Controller shutdown indicates a problem in the system requiring correction.</p>	<p>Fire extinguishing equipment must be present in the spray area and tested periodically.</p> <p>Spray areas must be kept clean to prevent the accumulation of combustible residues.</p> <p>Smoking must never be allowed in the spray area.</p> <p>The high voltage supplied to the atomizer must be turned off prior to cleaning, flushing or maintenance.</p> <p>When using solvents for cleaning:</p> <ul style="list-style-type: none"> <li>• Those used for equipment flushing should have flash points equal to or higher than those of the coating material.</li> <li>• The flash point of the cleaning solvent shall be at least 15° C (27° F) above the ambient temperature. Otherwise, the cleaning process must be carried out in an area with forced air ventilation. It is the end users responsibility to insure this condition is met.</li> </ul> <p>Spray booth ventilation must be kept at the rates required by NFPA-33, OSHA, country, and local codes. In addition, ventilation must be maintained during cleaning operations using flammable or combustible solvents.</p> <p>Electrostatic arcing must be prevented. Safe sparking distance must be maintained between the parts being coated and the applicator. A distance of 1 inch for every 10KV of output voltage is required at all times.</p> <p>Test only in areas free of combustible material. Testing may require high voltage to be on, but only as instructed.</p> <p>Non-factory replacement parts or unauthorized equipment modifications may cause fire or injury.</p> <p>If used, the key switch bypass is intended for use only during setup operations. Production should never be done with safety interlocks disabled.</p> <p>Never use equipment intended for use in waterborne installations to spray solvent based materials.</p> <p>The paint process and equipment should be set up and operated in accordance with NFPA-33, NEC, OSHA, local, country, and European Health and Safety Norms.</p> <div style="text-align: right; margin-top: 20px;">  </div>

<p><b>AREA</b> Tells where hazards may occur.</p>	<p><b>HAZARD</b> Tells what the hazard is.</p>	<p><b>SAFEGUARDS</b> Tells how to avoid the hazard.</p>
<p><b>Spray Area</b></p> 	<p><b>Explosion Hazard</b></p> <p>Improper or inadequate operation and maintenance procedures will cause a fire hazard.</p> <p>Protection against inadvertent arcing that is capable of causing fire or explosion is lost if any safety interlocks are disabled during operation.</p> <p>Frequent Power Supply or Controller shutdown indicates a problem in the system requiring correction.</p>	<p>Electrostatic arcing must be prevented. Safe sparking distance must be maintained between the parts being coated and the applicator. A distance of 1 inch for every 10KV of output voltage is required at all times.</p> <p>Unless specifically approved for use in hazardous locations, all electrical equipment must be located <b>outside</b> Class I or II, Division 1 or 2 hazardous areas, in accordance with NFPA-33.</p> <p>Test only in areas free of flammable or combustible materials.</p> <p>The current overload sensitivity (if equipped) <b>MUST</b> be set as described in the corresponding section of the equipment manual. Protection against inadvertent arcing that is capable of causing fire or explosion is lost if the current overload sensitivity is not properly set. Frequent power supply shutdown indicates a problem in the system which requires correction.</p> <p>Always turn the control panel power off prior to flushing, cleaning, or working on spray system equipment.</p> <p>Before turning high voltage on, make sure no objects are within the safe sparking distance.</p> <p>Ensure that the control panel is interlocked with the ventilation system and conveyor in accordance with NFPA-33, EN 50176.</p> <p>Have fire extinguishing equipment readily available and tested periodically.</p>
<p><b>General Use and Maintenance</b></p>  	<p>Improper operation or maintenance may create a hazard.</p> <p>Personnel must be properly trained in the use of this equipment.</p>	<p>Personnel must be given training in accordance with the requirements of NFPA-33, EN 60079-0.</p> <p>Instructions and safety precautions must be read and understood prior to using this equipment.</p> <p>Comply with appropriate local, state, and national codes governing ventilation, fire protection, operation maintenance, and housekeeping. Reference OSHA, NFPA-33, EN Norms and your insurance company requirements.</p> 

<p><b>AREA</b> Tells where hazards may occur.</p>	<p><b>HAZARD</b> Tells what the hazard is.</p>	<p><b>SAFEGUARDS</b> Tells how to avoid the hazard.</p>
<p><b>Spray Area / High Voltage Equipment</b></p>  	<p><b>Electrical Discharge</b></p> <p>There is a high voltage device that can induce an electrical charge on ungrounded objects which is capable of igniting coating materials.</p> <p>Inadequate grounding will cause a spark hazard. A spark can ignite many coating materials and cause a fire or explosion.</p>	<p>Parts being sprayed and operators in the spray area must be properly grounded.</p> <p>Parts being sprayed must be supported on conveyors or hangers that are properly grounded. The resistance between the part and earth ground must not exceed 1 meg ohm. (Refer to NFPA-33.)</p> <p>Operators must be grounded. Rubber soled insulating shoes should not be worn. Grounding straps on wrists or legs may be used to assure adequate ground contact.</p> <p>Operators must not be wearing or carrying any ungrounded metal objects.</p> <p>When using an electrostatic handgun, operators must assure contact with the handle of the applicator via conductive gloves or gloves with the palm section cut out.</p> <p>NOTE: REFER TO NFPA-33 OR SPECIFIC COUNTRY SAFETY CODES REGARDING PROPER OPERATOR GROUNDING.</p> <p>All electrically conductive objects in the spray area, with the exception of those objects required by the process to be at high voltage, must be grounded. Grounded conductive flooring must be provided in the spray area.</p> <p>Always turn off the power supply prior to flushing, cleaning, or working on spray system equipment.</p> <p>Unless specifically approved for use in hazardous locations, all electrical equipment must be located <b>outside</b> Class I or II, Division 1 or 2 hazardous areas, in accordance with NFPA-33.</p> 

<p><b>AREA</b> Tells where hazards may occur.</p>	<p><b>HAZARD</b> Tells what the hazard is.</p>	<p><b>SAFEGUARDS</b> Tells how to avoid the hazard.</p>
<p><b>Electrical Equipment</b></p> 	<p><b>Electrical Discharge</b></p> <p>High voltage equipment is utilized in the process. Arcing in the vicinity of flammable or combustible materials may occur. Personnel are exposed to high voltage during operation and maintenance.</p> <p>Protection against inadvertent arcing that may cause a fire or explosion is lost if safety circuits are disabled during operation.</p> <p>Frequent power supply shut-down indicates a problem in the system which requires correction.</p> <p>An electrical arc can ignite coating materials and cause a fire or explosion.</p>	<p>Unless specifically approved for use in hazardous locations, the power supply, control cabinet, and all other electrical equipment must be located outside Class I or II, Division 1 and 2 hazardous areas in accordance with NFPA-33 and EN 50176.</p> <p>Turn the power supply OFF before working on the equipment.</p> <p>Test only in areas free of flammable or combustible material.</p> <p>Testing may require high voltage to be on, but only as instructed.</p> <p>Production should never be done with the safety circuits disabled.</p> <p>Before turning the high voltage on, make sure no objects are within the sparking distance.</p>
<p><b>Toxic Substances</b></p> 	<p>Certain material may be harmful if inhaled, or if there is contact with the skin.</p>	<p>Follow the requirements of the Material Safety Data Sheet supplied by coating material manufacturer.</p> <p>Adequate exhaust must be provided to keep the air free of accumulations of toxic materials.</p> <p>Use a mask or respirator whenever there is a chance of inhaling sprayed materials. The mask must be compatible with the material being sprayed and its concentration. Equipment must be as prescribed by an industrial hygienist or safety expert, and be NIOSH approved.</p>
<p><b>Spray Area</b></p>  	<p><b>Explosion Hazard – Incompatible Materials</b></p> <p>Halogenated hydrocarbon solvents for example: methylene chloride and 1,1,1,-Trichloroethane are not chemically compatible with the aluminum that might be used in many system components. The chemical reaction caused by these solvents reacting with aluminum can become violent and lead to an equipment explosion.</p>	<p>Aluminum is widely used in other spray application equipment - such as material pumps, regulators, triggering valves, etc. Halogenated hydrocarbon solvents must never be used with aluminum equipment during spraying, flushing, or cleaning. Read the label or data sheet for the material you intend to spray. If in doubt as to whether or not a coating or cleaning material is compatible, contact your coating supplier. Any other type of solvent may be used with aluminum equipment.</p> 





# ATEX REQUIREMENTS

## Atex Requirements

This product provides an indirect charge to water based materials that will improve the transfer efficiency over non-electrostatic products. Because it is In-Direct charge, the fluid delivery system may be completely grounded from the source all the way to the applicator. Because this product uses water based materials only, there may be no requirement for an Atex approval. As long as the material being used meets the flammability definition as stated in EN 50 059: 1991\*\*, there is no hazardous area that must be zoned around the applicator. No Atex approval is required. It is the end users responsibility to insure all of these conditions are met.

## \*\*EN 50 059: 1991 Definition of non-flammable spraying material

The material applied by means of electrostatic hand held spraying equipment and which cannot be ignited, when in any mixture with air, by an energy source less than 500 mJ.

# FM REQUIREMENTS

## Requirements

These applicators are FM approved when the product setup is configured to drawings shown on pages 7, 8, and 9. This product is approved for use only with non-flammable water-based materials when the materials meet the FM definition for a waterbased spray material\*. It is the end users' responsibility to insure the material that is sprayed meets this requirement.

\* FM 7260 waterbased spray material - a material that does not sustain burning when tested in accordance with ASTM D 4206.



Label 80523-01

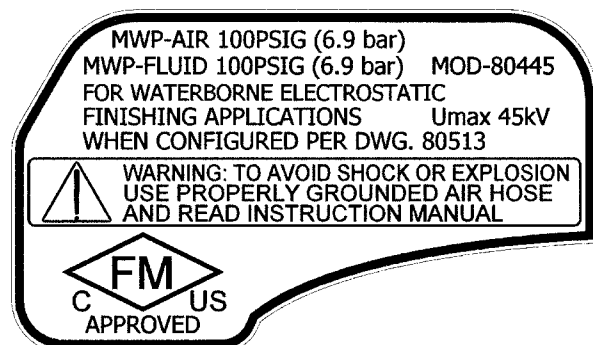

Label 80523-00



## RANSFLEX RXI - SOLVENT BASE ONLY

### 80445 - ABCDEF

Base Model No.	Optional Designations

(Ordering Information Only)



CONFIGURATION DWG. 80513-00  
REV. A



“R” (Air Cap)



“S” (Fluid Nozzle)



“T” (Pressure Reducer)

### ATOMIZATION - TABLE OF “A” DASHES

“A” Dash No.	“A” Description	“R”	“S”	“T”
0	T SERIES 1.2mm	80383-00	80239-12	74963-05
1	T SERIES 1.4mm	80383-00	80239-14	74963-05
2	T SERIES 1.8mm	80383-00	80239-18	74963-05
3	T SERIES 1.0mm	80383-00	80239-10	74963-05
4	T SERIES 0.7mm	80383-00	80239-07	74963-05



80262-01 “U”



80262-00 “U”

### FLUID CONTROL - TABLE OF “B” DASHES

“B” Dash No.	“B” Description	“U”
1	ADJUSTABLE FLUID	80262-00
2	NON-ADJUSTABLE FLUID	80262-01



80211-00 “V”

### TRIGGER - TABLE OF “C” DASHES

“C” Dash No.	“C” Description	“V”
1	2 FINGER TRIGGER	80211-00
2	4 FINGER TRIGGER	80386-00*



“W” → 80269-45

**FLUID INLET - TABLE OF “D” DASHES**

“D” Dash No.	“D” Description	“W”
1	STD FLUID INLET TUBE	80269-45

**FLUID HOSE - TABLE OF “E” DASHES**

“E” Dash No.	“E” Description	“X”
0	NO FLUID HOSE	---
1	FLUID HOSE, 10m	80303-10
2	FLUID HOSE, 15m	80303-15
3	FLUID HOSE, 20m	80303-20
4	FLUID HOSE, 30m	80303-30



**AIR HOSE - TABLE OF “F” DASHES**

“F” Dash No.	“F” Description	“Y”	“Z”
0	NO AIR HOSE, STANDARD	---	80236-00
1	STANDARD AIR HOSE, 10m	79727-10	80236-00
2	STANDARD AIR HOSE, 15m	79727-15	80236-00
3	STANDARD AIR HOSE, 20m	79727-20	80236-00
4	STANDARD AIR HOSE, 30m	79727-30	80236-00
5	NO AIR HOSE, QD	---	80302-00
6	QD AIR HOSE, 10m	79727-11	80302-00
7	QD AIR HOSE, 15m	79727-16	80302-00
8	QD AIR HOSE, 20m	79727-21	80302-00
9	QD AIR HOSE, 30m	79727-31	80302-00



# INTRODUCTION

## GENERAL DESCRIPTION

The **Ransflex** is an air atomizing applicator powered only by a pressurized air source. Pressurized air creates rotation of a turbine generator that powers a cascade. The cascade generates a high voltage DC charge to the electrode creating an electrostatic field between the atomizer and the target.

One of the many features of the Ransflex applicator system is that the electrical energy, which is available from the resistive charging electrode, is limited to the optimum level of safety and efficiency. The system is incapable of releasing sufficient electrical or thermal energy during normal operating conditions to cause ignition of specific hazardous materials in their most easily ignited concentrations in air.

As the applicator electrode approaches ground, applicator circuitry causes the high voltage to approach zero while the current approaches its maximum value. This performance is validated by independent test agencies that give ATEX EN 50 050 approvals of FM 7260 approvals.

This Ransflex model is designed specifically for indirect charge waterbase applications only. The design eliminates the need for isolation equipment normally needed for use with electrostatic waterborne applications.

The water base materials must be classified as non-flammable spray material. This means the mixture with air cannot be ignited by an energy source less than 500 mJ.

## RANSFLEX NEW FEATURES

- Light weight and easy to maneuver.
- Ergonomic handle design to reduce operator fatigue.
- Three phases of turbine protection:
  - Divorced turbine air supply cartridge
  - Sealed nozzle/Atomization passages
  - Strategic turbine location
- DeVilbiss spray technology integration into atomization.
- Simultaneous fan/atom pressure adjustment with compensation valve.



## 80445 RANSFLEX INDIRECT CHARGE WATERBASE

### SPECIFICATIONS

#### Environmental/Physical

<b>Applicator Length:</b>	254mm (10-inches)
<b>Weight: (Without Hose)</b>	600 grams (21.3 oz.)
<b>Hose 79727-XX Lengths (Std):</b>	10m, 15m, 20m, and 30m

#### Electrical

<b>Operating Voltage:</b>	45kV DC (-) maximum
<b>Current Output:</b>	140 microamperes maximum
<b>Paint Resistance:*</b>	Waterbase paint only with grounded source
<b>Part Sprayability:</b>	Determine sprayability of part to be coated using 76652, Test Equipment

(See current "Paint, HV & SCI Test Equipment" service manual TE-98-01)

\* Use Model No. 76652, Test Equipment

#### Mechanical

<b>Fluid Flow Capacity:</b>	1000 ml/minute**
<b>Wetted Parts:</b>	Stainless, polyethylene, nylon, acetal polymer
<b>Operating Pressure (Air Spray)</b>	
<b>Fluid:</b>	(0-6.9 bar) 0-100 psi
<b>Air:</b>	(0-6.9 bar) 0-100 psi
<b>Ambient Temp.:</b>	40°C to 5°C (104°F to 32°F)
<b>Consumption (With Voltage):</b>	438 SLPM (15.4 SCFM) @ 2.8 bar (40 psig) @ Handle Inlet
<b>Sound Level:</b>	92dB (A) @ 2.8 bar (40 psig) Inlet, 1m from applicator

\*\* This reflects the maximum fluid volume the applicator can deliver. The maximum spray volume that can be effectively atomized depends on fluid rheology, spray technology, and finish quality required.

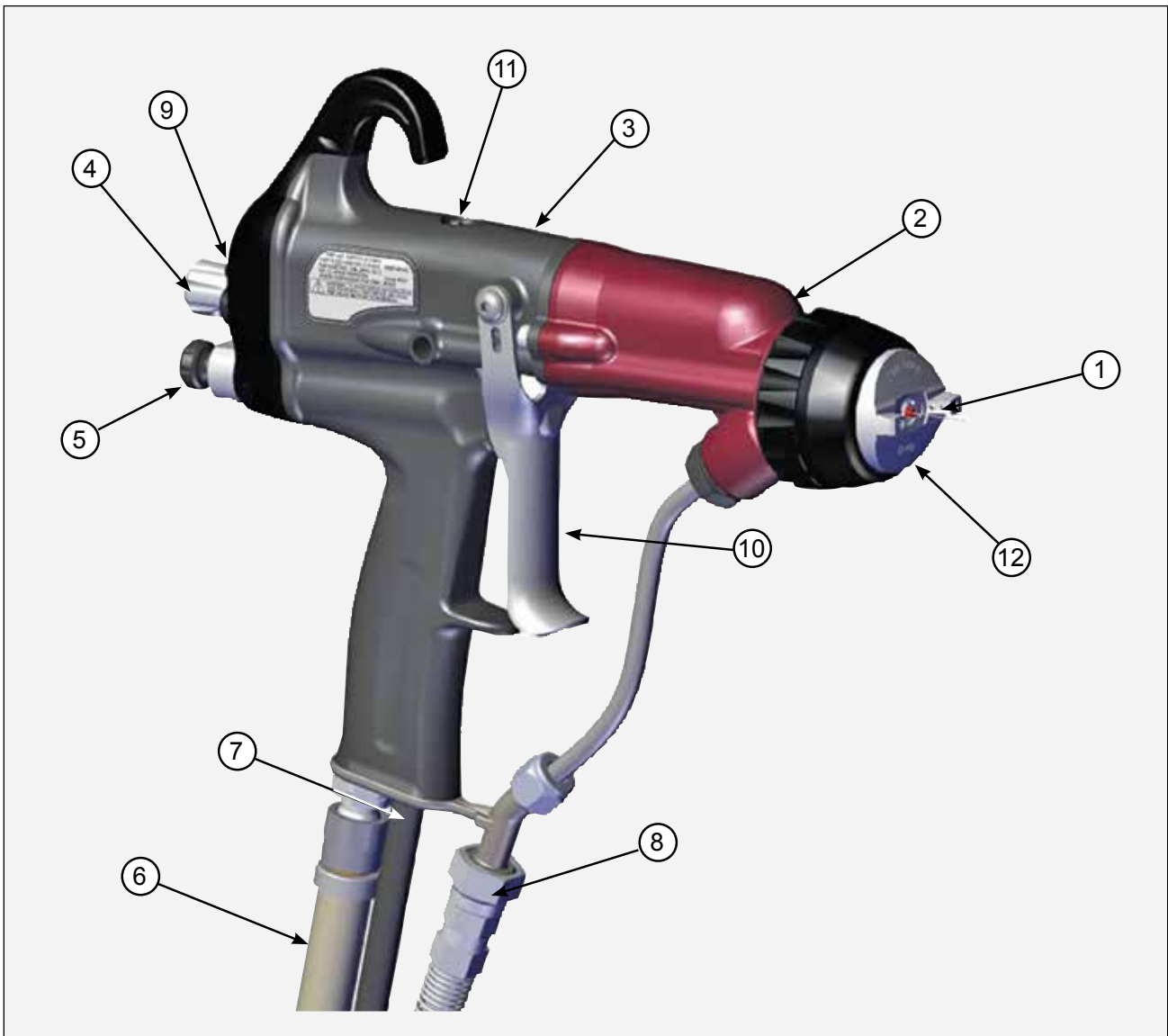

Figure 1: Ransflex Indirect Charge Waterborne Electrostatic Spray Applicator 80445

**RANSFLEX INDIRECT CHARGE WATERBORNE ELECTROSTATIC SPRAY APPLICATOR 80445**

No.	Description	No.	Description
1	Needle/Electrode	7	Exhaust Air Hose
2	Barrel	8	Fluid Hose
3	Handle	9	Voltage On/Off Switch
4	Fan Adjustment	10	Trigger
5	Fluid Adjustment	11	Compensation Valve
6	Air Hose	12	Air Cap with Charging Electrodes / Fluid Nozzle

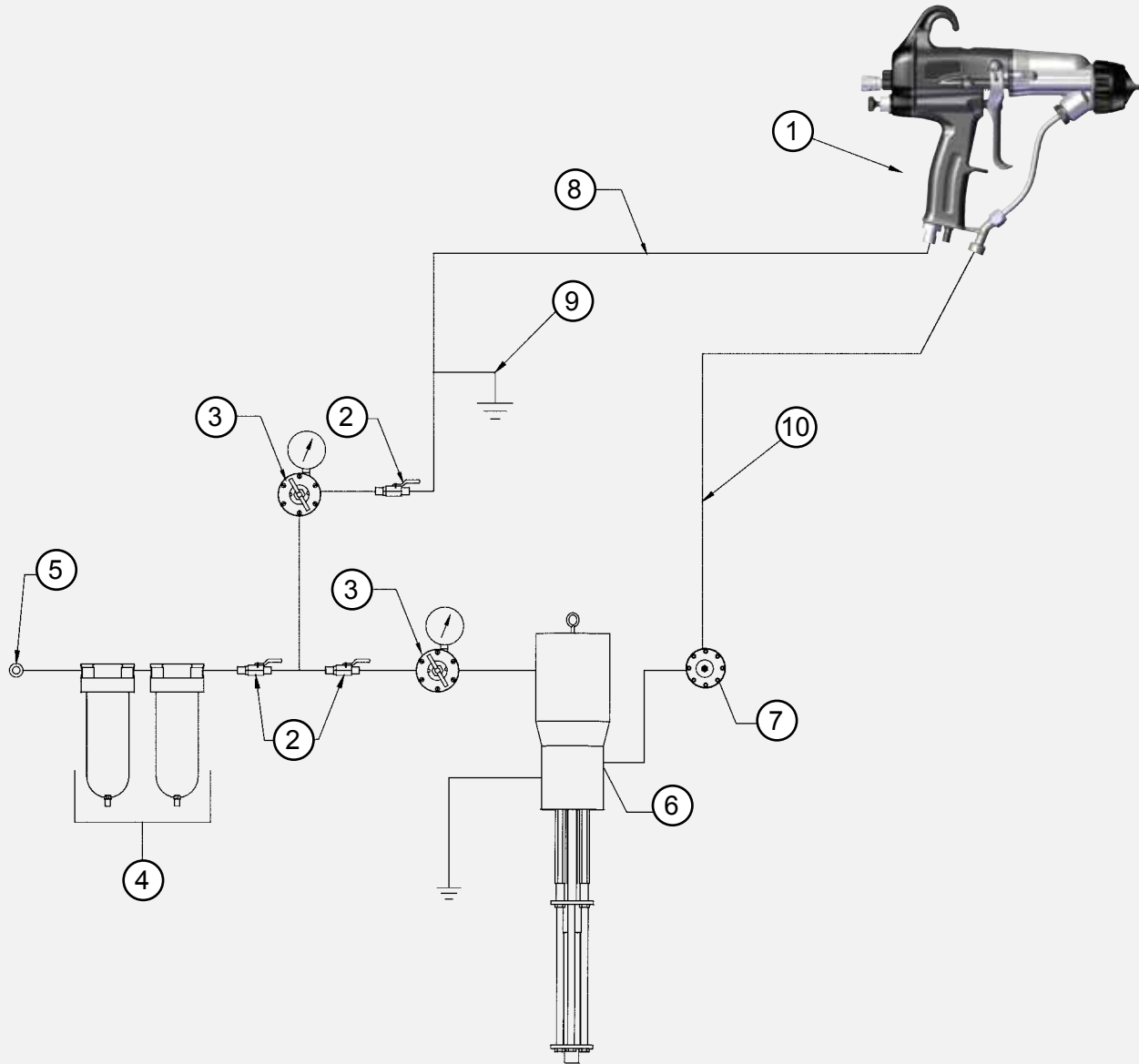

Figure 2: Ransflex Installation for Waterbase Materials

**RANSFLEX INDIRECT CHARGE WATERBASE TYPICAL INSTALLATION**

No.	Description	No.	Description
1	Ransflex	6	Fluid Supply (Grounded)
2	Ball Valve	7	Fluid Regulator
3	Air Regulator with Pressure Gauge	8	Air Hose (79727-XX)
4	Air / Water Separator	9	Air Hose Ground Wire
5	Main Air Supply Line	10	Fluid Line





# INSTALLATION



## Air Hose

### ⚠ WARNING

- For proper safe function of the applicator and operator the 79727-XX Air Hose Assembly must be used (either standard or quick disconnect style).

## Fluid Hose Recommendation

Ransburg recommends using a 80303-XX Fluid Hose Assembly. This assembly is made to specifically fit the fluid fitting size engineered into the applicator. This hose is available from your authorized Ransburg distributor. Available hose lengths are listed in "Accessories" in the "Parts Identification" section of this manual.

### ⚠ CAUTION

- Any user installed fluid hose used must be rated for (100 psig) 6.9 bar working pressure minimum.

## Filters

1. Install an air filter assembly on the outlet of the main air regulator. The filter should be 5 micron with a maximum working pressure of at least 100 psig (6.9 bar). For Class 3 air quality, which is a 5 micron size and has a dew point of -4°F (-20°C), the relative humidity (RH) of the air should be 5%.
2. Ransburg recommends that a fluid filter be installed at the output of the fluid supply (pressure pot, pump, circulating system, etc.). It is the end user's responsibility to install the proper filter that meets their system's requirements.

## 80445 RANSFLEX INDIRECT CHARGE WATERBORNE INSTALLATION

### ⚠ WARNING

- This applicator is for use with non-flammable water base materials only. The material when atomized cannot be ignited by an energy greater than 500mJ. Consult your paint supplier to insure your material meets these requirements.
- Material that will not sustain burning when tested in accordance with ASTM D 4206.

### ⚠ WARNING

- The user **MUST** read and be familiar with the "Safety" section of this manual.
- This hand held device is intended to be used by trained personnel **ONLY**.
- This manual **MUST** be read and thoroughly understood by **ALL** personnel who operate, clean, or maintain this equipment! Special care should be taken to ensure that the warnings and requirements for operating and servicing safely are followed. The user should be aware of and adhere to **ALL** local building and fire codes and ordinances as well as NFPA, OSHA, and all related country safety codes prior to installing, operating, and/or servicing this equipment.
- Personnel **MUST** be **GROUNDING** to prevent a shock or spark during electrostatic operation.
- Install and route the hoses so they are **NOT** exposed to temperatures in excess of 120° F (49° C) and so that all hose bends are **NO LESS** than a 6-inch (15cm) radius. Failure to comply with these parameters could cause equipment malfunction that might create **HAZARDOUS CONDITIONS!**

## GENERAL INSTALLATION REQUIREMENTS

1. Operator must make skin contact with handle of applicator. If gloves are required use either gloves with palm and finger cut out or conductive gloves. See accessory pages for conductive gloves.

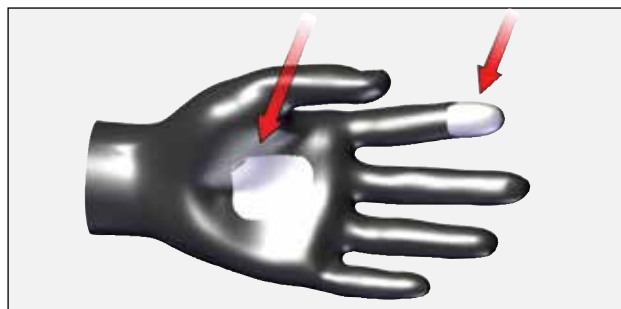



2. All objects inside spray area must be grounded - reference EN 50 176 and/or NFPA-33. Resistance to earth ground must be less than 1 meg Ohm.
3. Liquids must be contained in approved metallic grounded containers.

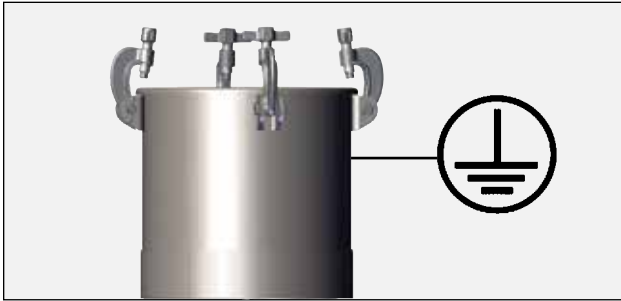

### Interlocks Required

Interlock the solvent supply with the main supply air to the applicator. When solvent is On, main supply air to the applicator is Off. Interlocks are user supplied.

#### **⚠ WARNING**

- The solvent supply must be interlocked with applicator supply air.

### INSTALLATION

1. Ensure there is a true earth ground connection available. Connect the fluid source and air hose ground to this connection.

#### **⚠ WARNING**

- Both the fluid source and the air hose ground must be connected to true earth ground.



2. Turn off power.



3. Connect fluid hose.

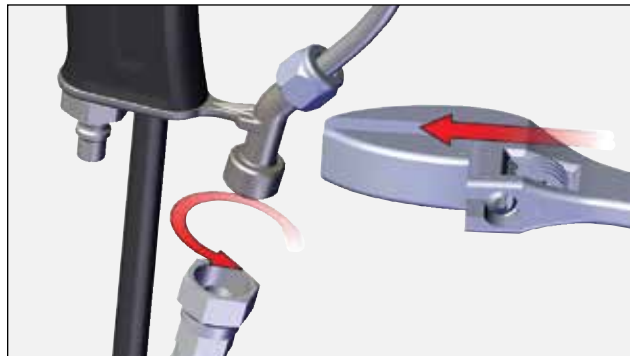

4. Connect air.

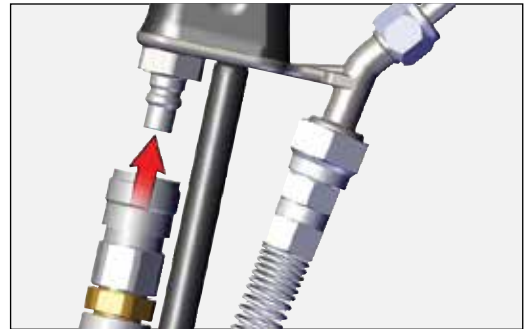

**OR...**



5. Trigger applicator with fluid off. Look for leaks in any connections
6. Activate fluid, check for leaks with solvent flush if required.



# OPERATION

## APPLICATOR OPERATION

1. Set fluid pressure using flow regulator.

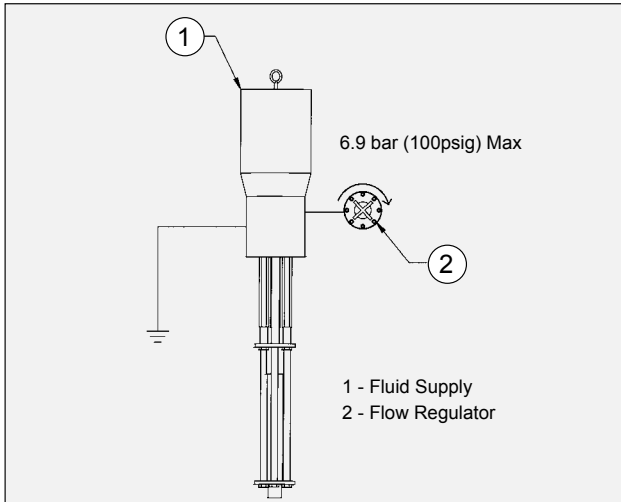

2. Disconnect the air to the applicator.

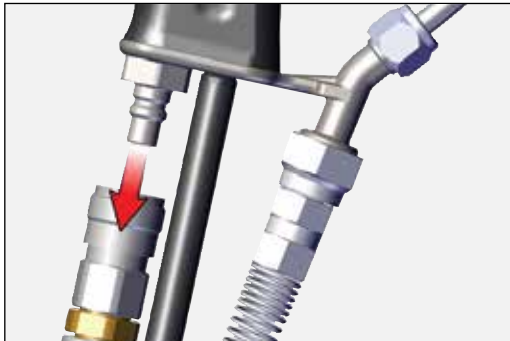

**OR...**



3. Activate trigger to start material stream into **grounded metal bucket or suitable area.**

**⚠ WARNING**

➤ The bucket or area sprayed into must be grounded to true earth ground.

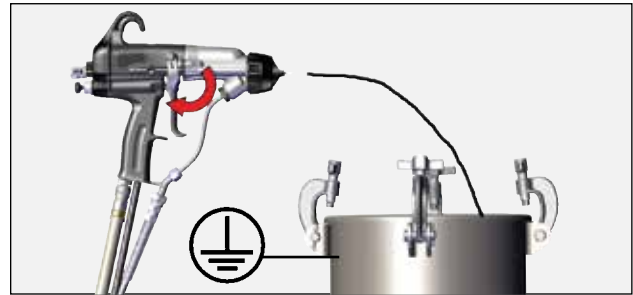

4. Release trigger stop material flow.



5. Re-connect air supply.

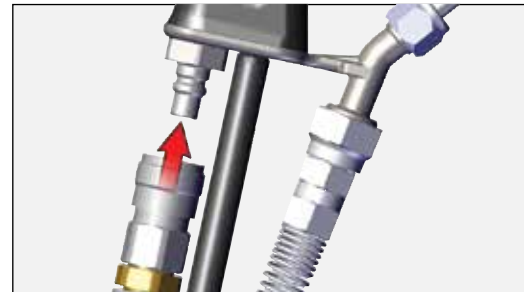

**OR...**

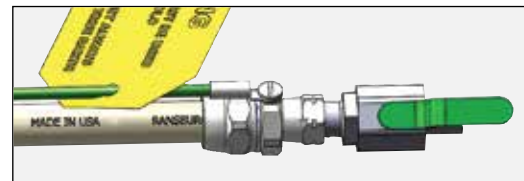

6. Adjust air pressure.
7. Position air cap to achieve pattern direction.
8. Actuate applicator (with voltage off) to spray test pattern.
9. As a guide, the tables below show a pressure at the wall to give 2.7 bar (40 psig) dynamic at the handle of the applicator with different hose lengths.



T-40 AIR CAP 80240-00				
79727-XX Length	Static Pressure at Wall		Dynamic Pressure at Wall	
	bar	psig	bar	psig
30 m	4.5	65	4.3	62
20 m	4.3	62	3.9	57
15 m	4.1	60	3.8	55
10 m	4.0	58	3.7	53

10. Turn on voltage and trigger applicator. Green light should be on.

11. Adjust fluid pressure and air pressure as required to achieve finish.

12. Adjust air cap position as required.

13. Adjust fan pattern as required.



(Horns Horizontal)

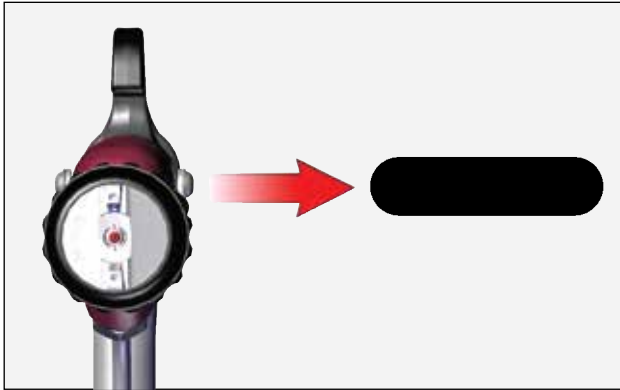

(Horns Vertical)

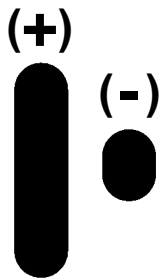

14. Adjust fluid flow.

**NOTE**

➤ It is recommended fluid flow be controlled by the supply regulator. This adjustment should only be used for fine adjustments.

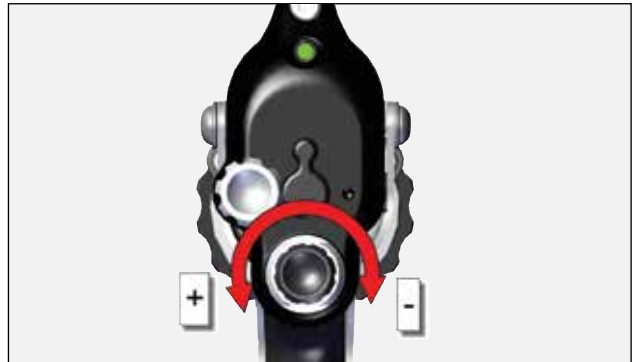

15. Adjust compensation valve with small driver.

**NOTE**

➤ The compensation valve adjustment is used to adjust fan and atomization pressure at the same time when the pressure to run the turbine is higher than the atomization fan pressure desired.



### FLUSHING / COLOR CHANGE PROCEDURE

1. Turn off electrostatics.





**⚠ WARNING**

➤ The solvent supply must be interlocked with the applicator supply air.

2. Disconnect air to applicator.

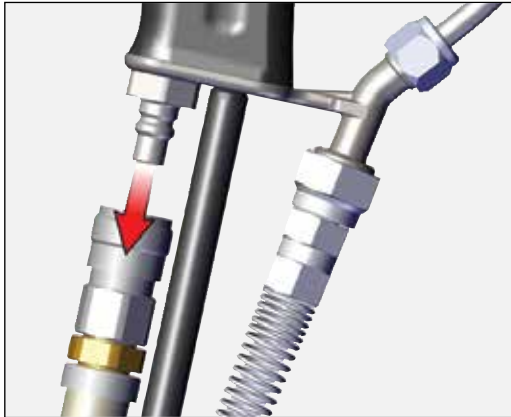

**OR...**

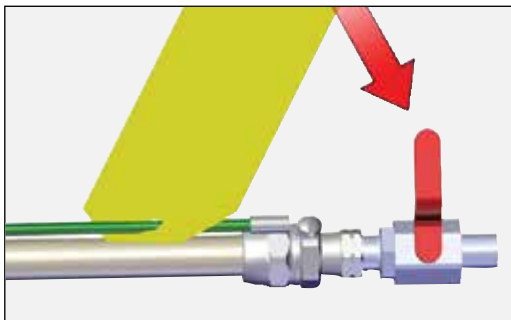

3. Discharge fluid into appropriate earth grounded metal container

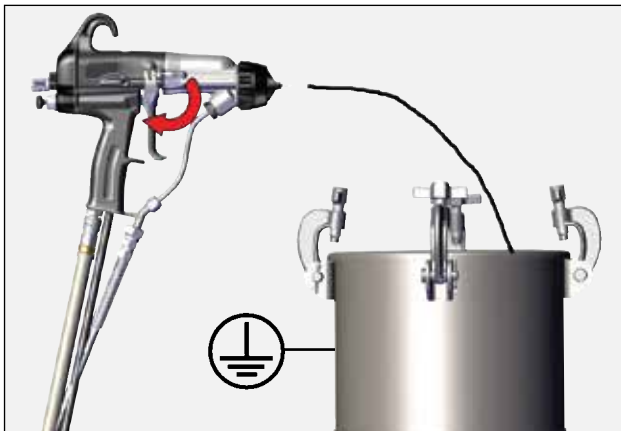

4. Load next color, solvent flush and/or remove applicator from installation as required.

## FLUID NOZZLE / AIR CAP

The fluid nozzle and air cap must be selected according to the application. The following charts show the nozzles and air caps available for the Ransflex.

**⚠ CAUTION**

➤ Nozzles from previous Ransburg design are not compatible with the Ransflex design. Use of these nozzles could cause equipment malfunction and possible damage.

## NEW NOZZLE DESIGN

With the release of the Ransflex applicator a new configuration of nozzles was also released.

- Red nozzles - 1.2 mm I.D.
- Grey nozzles - 1.4 mm I.D.
- Green nozzles - 1.8 mm I.D.
- All other accessory sizes are black

Air cap to be used with nozzle.



Air cap part number







### 80383-00 / 80239-XX T SERIES

Nozzle Part Number	For Use With Air Cap P/N	Color	Nozzle Opening
80239-07	80383-00	Black	0.7 mm
80239-10	80383-00	Black	1.0 mm
80239-12	80383-00	Red	1.2 mm
80239-14	80383-00	Grey	1.4 mm
80239-18	80383-00	Green	1.8 mm

## AIR CAP / NOZZLE PERFORMANCE

### T-40 - 80383-00

Nozzle	Orifice ID (mm/in)	*Fluid Delivery (ml/min)	Spray Type	Pattern Length (mm/in)	Pattern Width (mm/in)	Pressure Reducer
80239-12	1.2/.047	250	LVMP	330/13.0	76/3.0	74963-05 (Black)
80239-14	1.4/.055	250	LVMP	310/12.2	76/3.0	74963-05 (Black)
80239-18	1.8/.070	250	LVMP	292/11.5	76/3.0	74963-05 (Black)

\* Material: Enamel 24 sec. No. 4 Ford Cup @ 23° C (72°F).  
Results are material dependent.

\*\* Patterns are at 200mm (8") target distance.



# MAINTENANCE



## SUITABLE SOLVENTS FOR CLEANING RANSFLEX APPLICATORS

When cleaning the applicator, a suitable solvent for cleaning depends on the part(s) of the applicator to be cleaned and the material that needs to be removed. Ransburg recommends that all exterior cleaning be done with non-polar solvents to prevent a conductive residue on critical components. We also understand that some of these solvents do not always meet the cleaning needs of some materials. **If conductive polar solvents are used to clean the applicator components, all residue must be removed using a non-conductive non-polar solvent (i.e. high flash Naphtha).** If there are any questions as to what solvents are best for cleaning, contact your local Ransburg distributor and/or your paint supplier.

The RansFlex applicator, air hoses and fluid hose, should not be submerged or soaked in solvent. However, the outer surfaces of these items can be wiped with a suitable cleaning solvent.

### ⚠ CAUTION

- All electrical components **cannot** be cleaned or soaked in any solvents.

Please reference Solvent Selection Guide TL-15-01 for detailed information on solvent polarity. (Reference [www.ransburg.com](http://www.ransburg.com))

### ⚠ WARNING

- The user **MUST** read and be familiar with the safety instructions in this manual.
- If compressed air is used in cleaning, **REMEMBER** that high pressure air can be dangerous and should **NEVER** be used against the body. It can blind, deafen, and may even penetrate the skin. If used for cleaning equipment, the user should wear safety glasses.
- Be **SURE** the applicator power is **OFF** and the system is grounded before using solvent to clean **ANY** equipment.
- **DO NOT** operate a faulty applicator!
- When using cleaning solvent, standard health and safety precautions should apply.
- Any solvent used to clean the fluid passages must be discharged into a grounded container. Use of ungrounded or plastic containers may cause fire or explosion.

### ⚠ CAUTION

- Cleaning of the exterior surface of the applicator should be done with non-polar solvents. If cleaning requires the use of polar solvents, the applicator should be wiped down with non-polar solvent prior to going back into use. Using polar solvents will leave a semi-conductive film on the surface of the applicator that will effect efficiency of the applicator and cause damage to the components.





### ⚠ CAUTION

➤ Nozzles from previous Ransburg design are not compatible with the Ransflex design. Use of these nozzles could cause equipment malfunction and possible damage.

### ⚠ WARNING

➤ The flash point of the cleaning solvent shall be at least 15° C (27° F) above the ambient temperature. Otherwise, the cleaning process must be carried out in an area with forced air ventilation. It is the end users responsibility to insure this condition is met.

All repairs should be made on a clean, flat surface. If a vise is used to hold parts during service or repair, DO NOT clamp onto plastic parts and always pad the vise jaws!

The following parts should be thoroughly packed with dielectric grease (LSCH0009-00) leaving **NO** air space or voids when assembling:

- All O-Rings (PTFE o-rings do not need lubrication)
- Needle Shaft Assembly
- Packing Tube
- Cascade and Barrel

### Equipment Required

- Special Multi-Purpose Wrench (80353-00)\*
- Hex Driver (79862-02)\*
- Dielectric Grease (LSCH0009-00)\*
- 10 mm Wrench
- 15 mm Wrench
- Spanner

\* Supplied with applicator

## ROUTINE SCHEDULE

Follow these maintenance steps to extend the life of the applicator and ensure efficient operation:

### Several Times Daily

Inspect the air cap for paint accumulation. Clean as frequently as necessary with a soft bristled brush and a suitable solvent.

### ⚠ CAUTION

➤ **NEVER** remove the fluid nozzle assembly while paint is in the applicator or paint may enter into the air passages. Clogged or restricted air passages will cause poor atomization and/or electrical shorting. Air passages that are clogged with conductive material can lead to excessive current output levels and consequent low operating voltage or long-term electrical damage.

The applicator barrel **MUST** be tilted front down to remove the fluid nozzle. Failure to do so may allow paint to enter the air passages, thereby reducing airflow and damaging the applicator barrel/cascade. Applicators may be flushed in lieu of tilting. However, they must be either flushed or tilted down during nozzle removal!

## Cleaning Flushing

1. Reference page 18 and 19 for flushing procedure. Flushing should be performed at the end of daily use or prior to any maintenance.
2. Applicator exterior cleaning at the end of each shift, wipe the outside of the applicator with a solvent soaked rag pointing the applicator nose down. (Use non-polar solvents)





### Daily (or at start of each shift)

- Verify that ALL solvent safety containers are grounded!
- Check within 6m (20-ft.) of the point of operation (of the applicator) and remove or ground ALL loose or ungrounded objects.
- Inspect work holders for accumulated coating materials (and remove such accumulations).

- Check that atomizer assembly is clean and undamaged.

### NOTE

- Standard electrode is "snap back" spray wire electrode.

- Straighten the applicator electrode if necessary.
- Clean the fluid filter, if used.

### Bi-Yearly

- Check air hose resistance. If resistance is greater than .5 MΩ the hose should be replaced.

### ! WARNING

- It is the end users responsibility to insure the .5 MΩ to ground condition is met.

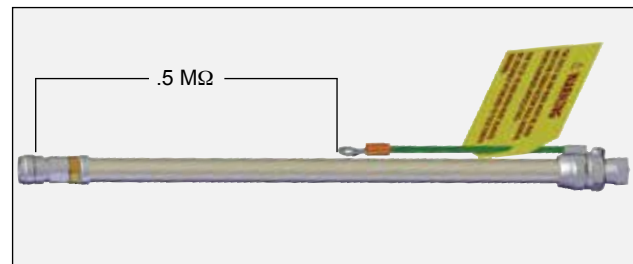

### Air Cap Removal

1. Remove retaining ring and air cap.

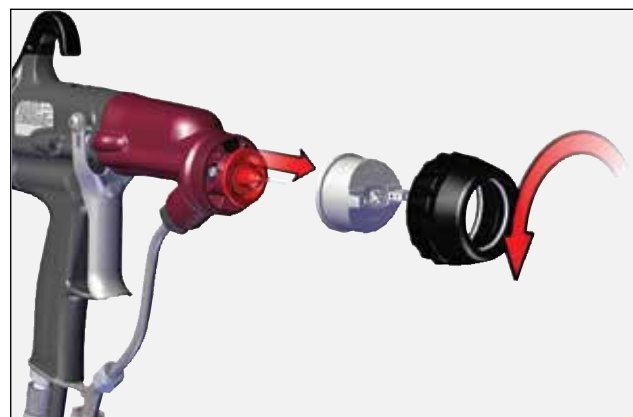



2. Clean and replace as necessary.
3. Install in reverse order.

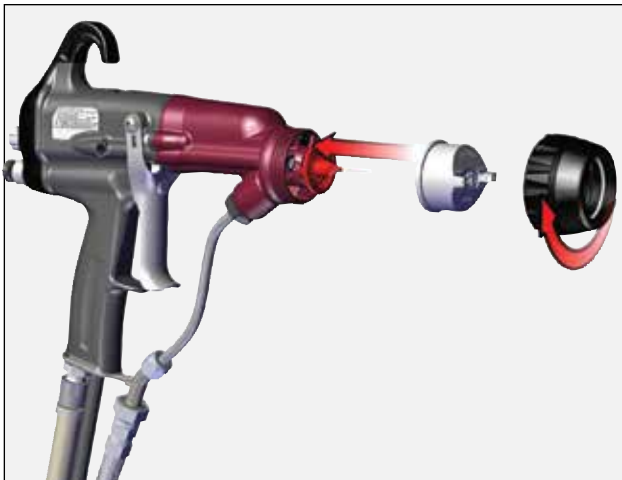

### Fluid Nozzle Removal

#### WARNING

- Prior to removing the fluid nozzle, all pressure from the system must be relieved.

1. Insert 80353-00 wrench onto nozzle flats.

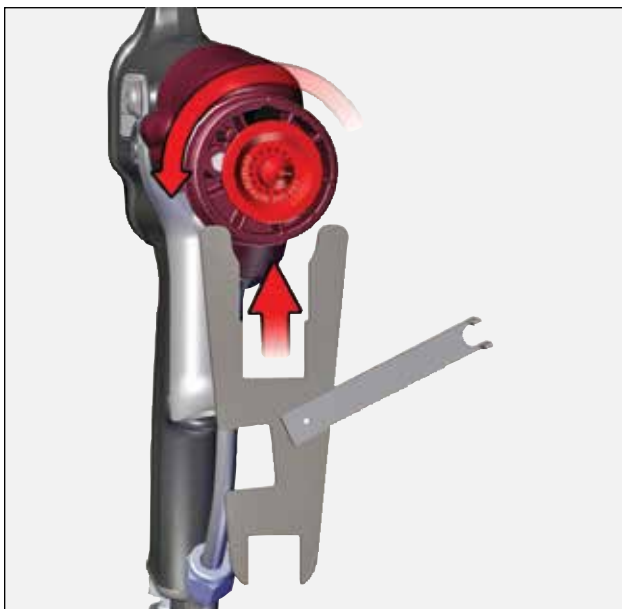

2. O-ring in barrel, replace as required.



3. Install fluid nozzle using 80353-00 wrench. Tighten till nozzle seats on O-ring and then 1/8 additional turn.

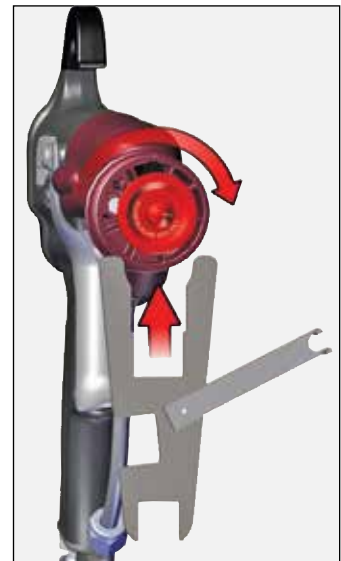

#### NOTE

- Do not over tighten. Fan pattern reduction will be effected

### Barrel Removal

1. Remove trigger.





2. Remove fluid tube.

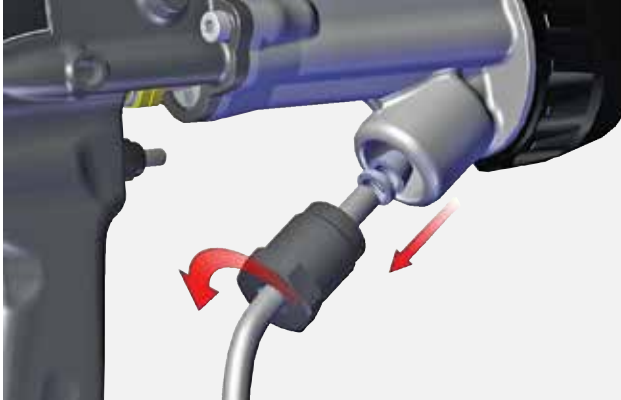

3. Pull barrel away.

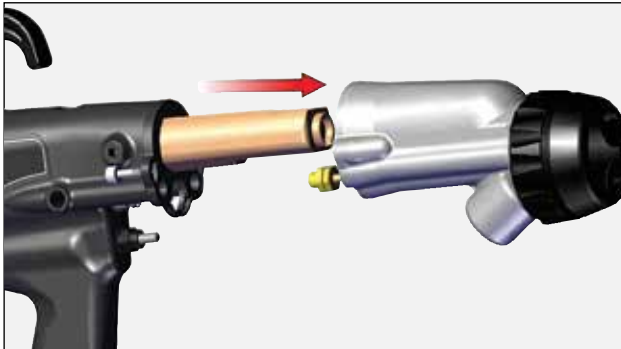

### Remove/Replace Cascade

1. Pull cascade straight out.

**⚠ CAUTION**

- Do not pull with excessive force or twist wires. This could damage cascade connector or wire harness.



2. Carefully disconnect harness by pulling connector on both sides by hand and rocking it side to side to remove.



3. Replace cascade as necessary.

4. Apply LSCH 0009 grease to end of cascade.

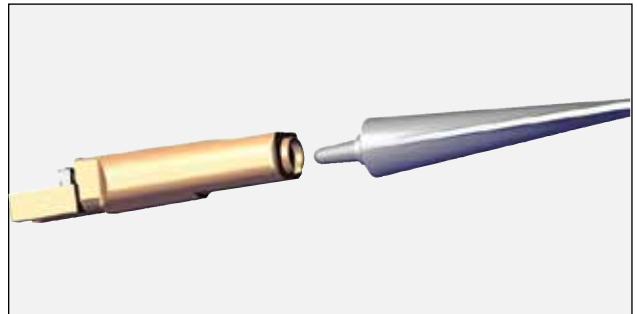

5. Re-connect harness by pushing down to snap.



6. Re-install cascade into handle.



### Packing Removal/Replace

1. Remove barrel from handle.
2. Use 80353 wrench to remove nut.

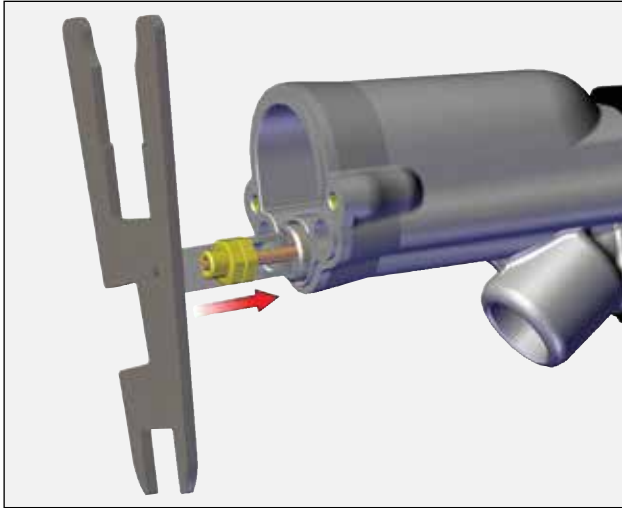

3. Pull straight out of barrel.

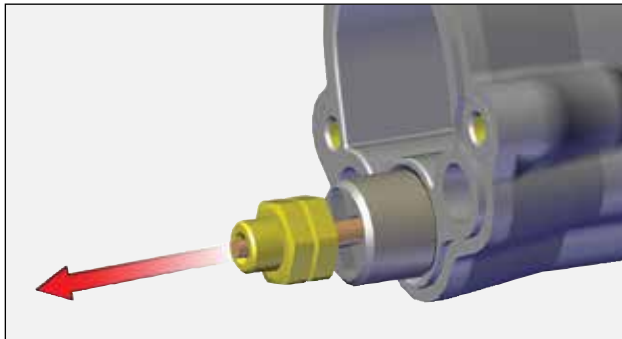

4. Remove jam nuts using 10mm wrench.

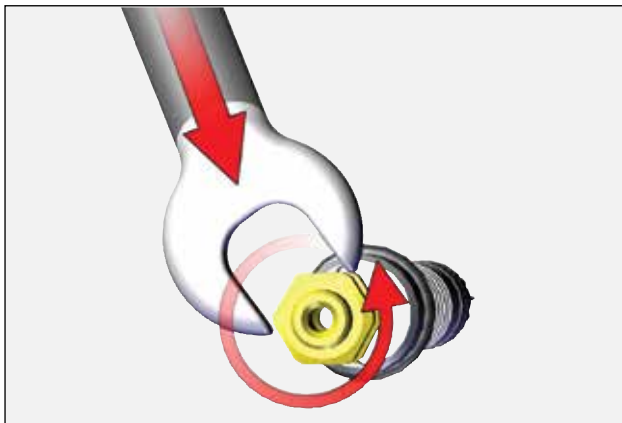

5. Remove all parts, clean with non-polar solvent. Inspect for any discolored areas. Replace parts as required.



6. Prior to installation apply dielectric grease inside packing tube, completely full.

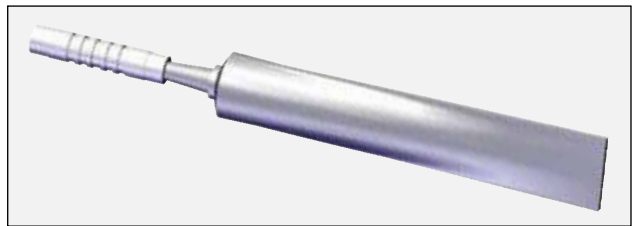

7. Insert parts on front of shaft.

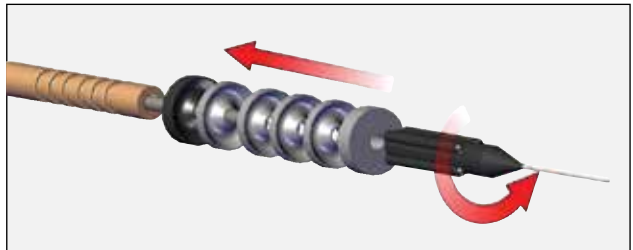

8. Insert packing tube onto shaft. Wipe excess grease over front parts and outside of packing tube.

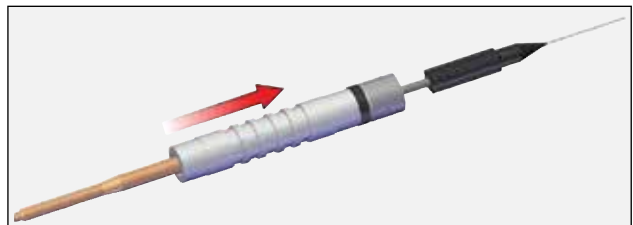

9. Install rear parts.

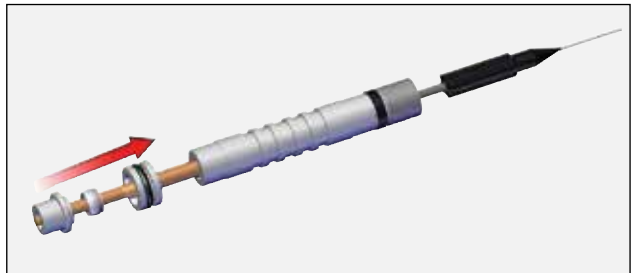





10. Install Bellville washers in sequence shown.

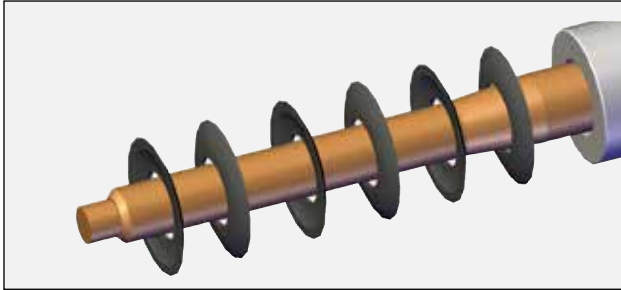

11. Install rear nut. Install jam nuts finger tight.

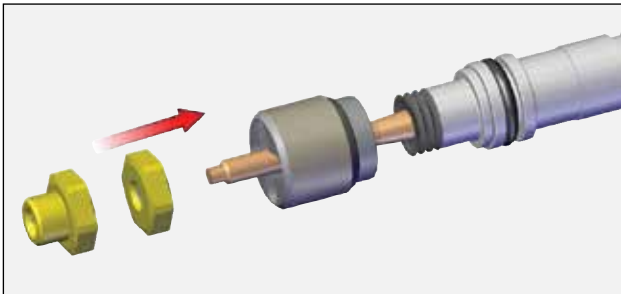

12. Set air before fluid adjustment.

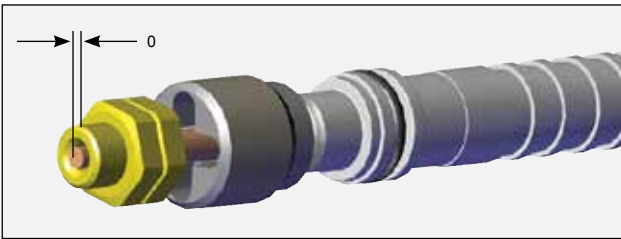

13. Tighten jam nuts.

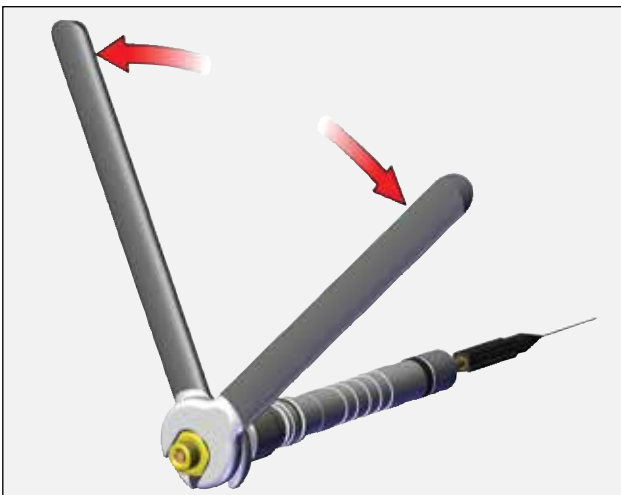

### Re-Install Needle Shaft Into Barrel

1. Install needle shaft into barrel with die-electric grease.

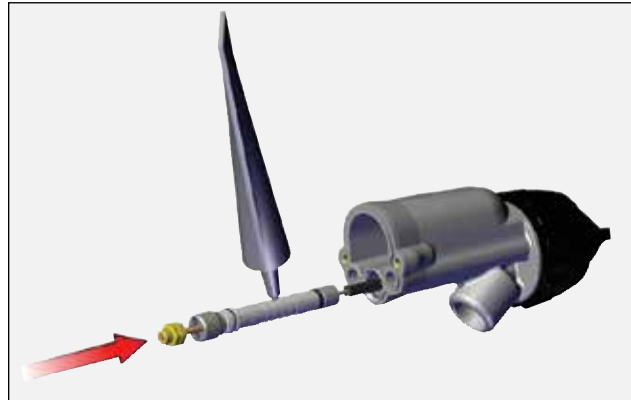

2. Tighten packing using wrench. Pull back and forth on the needle shaft till a slight amount of drag is felt.

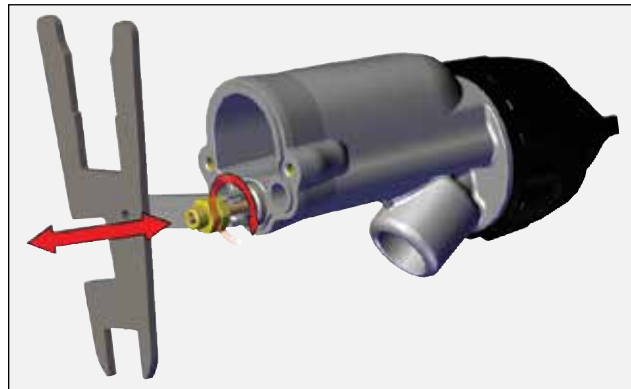

### Re-Install Barrel

1. Install barrel over cascade.

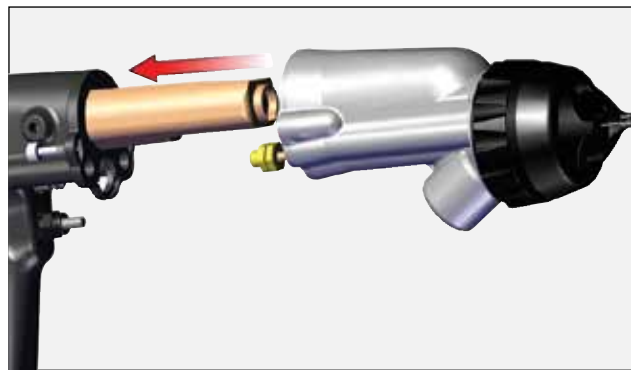



2. Tighten barrel screws.

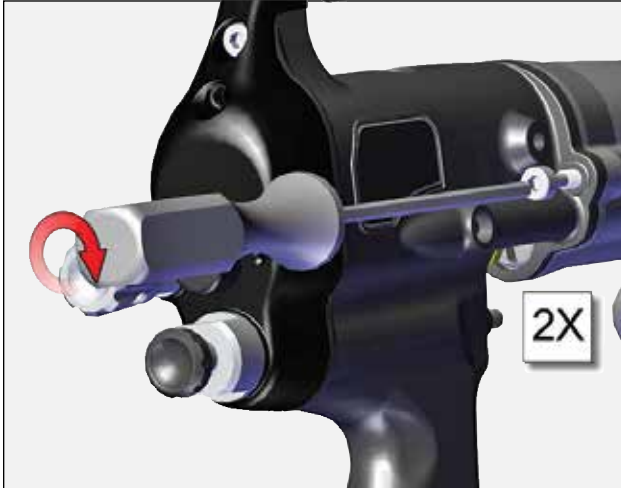

3. Re-install fluid tube.

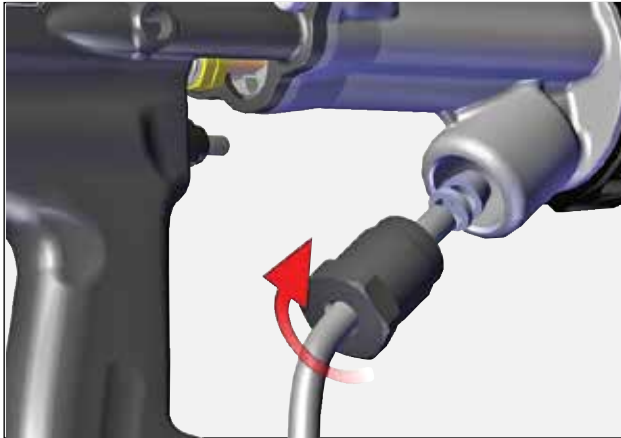

4. Re-install trigger.



### Rear Cover/Motor Module Repair

1. Loosen cover screw with 3mm driver.



2. Remove fan air cartridge with 10mm wrench.

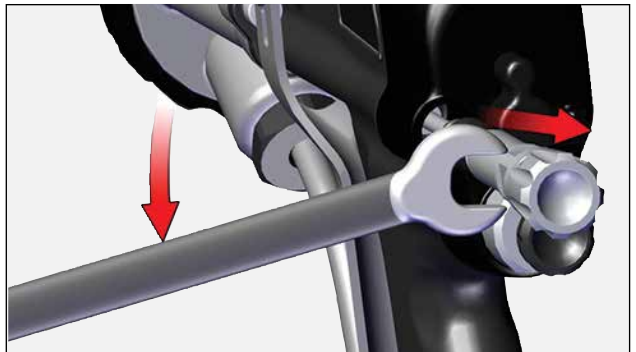

3. Remove rear cover and cartridge with 15mm wrench.



4. Disconnect motor connector from handle wire harness connector.



## Motor Removal

1. Remove light pipe.

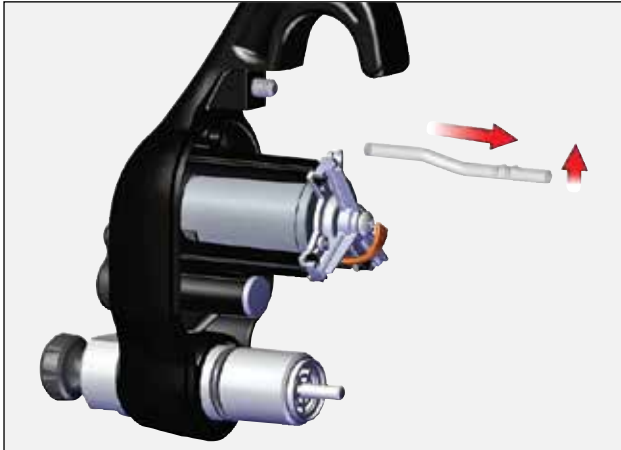

2. Remove screw and retainer.

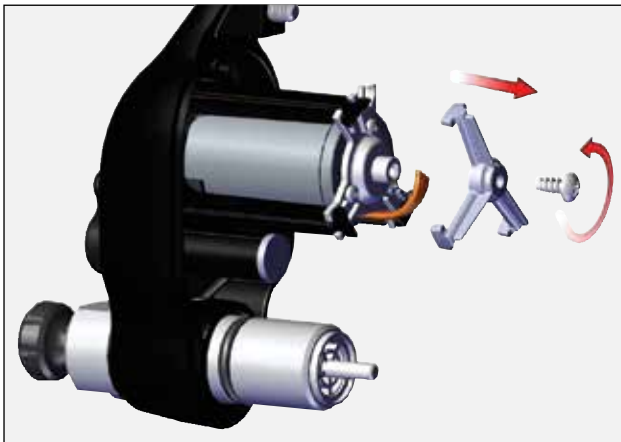

3. Remove motor assembly by pulling out on 3 arms, pull motor out.

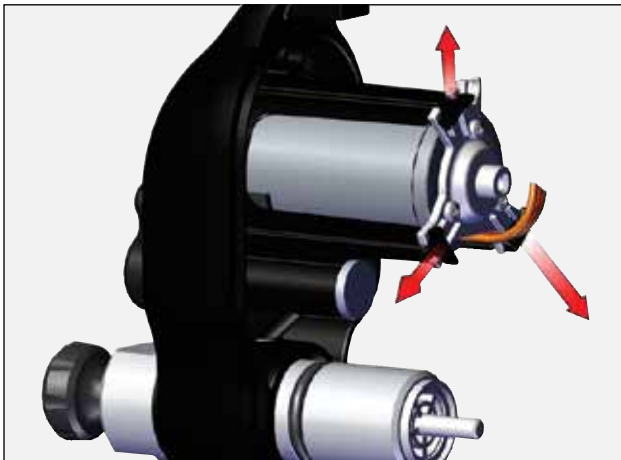

4. Remove porting block.



### NOTE

➤ Block must be pulled out with fingers rocking the part side to side while pulling.

### NOTE

➤ Only remove fluid valve cartridge if parts are being changed.

5. Remove fluid valve cartridge O-ring.

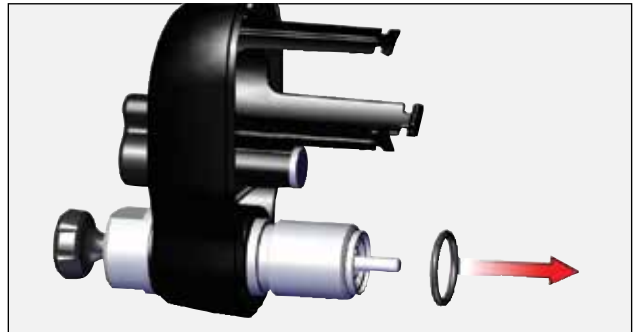

6. Push on edges to remove fluid valve cartridge.

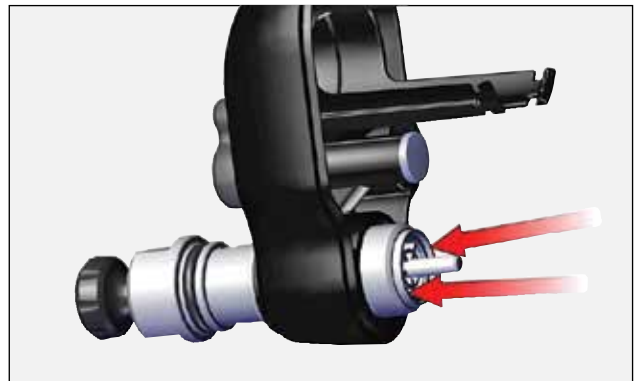





### Re-assembly

1. Install porting block on motor. Align screw heads into porting recess.

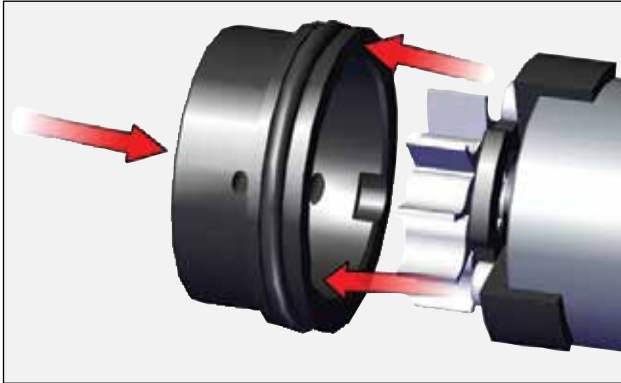

**NOTE**

➤ There is only one way to install the motor.

4. Install screw and retainer.

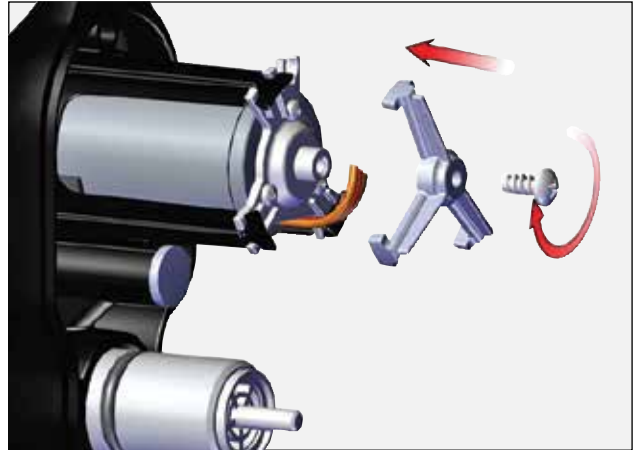

**NOTE**

➤ Only one way to position

2. Align motor slots with 3 tab arms.

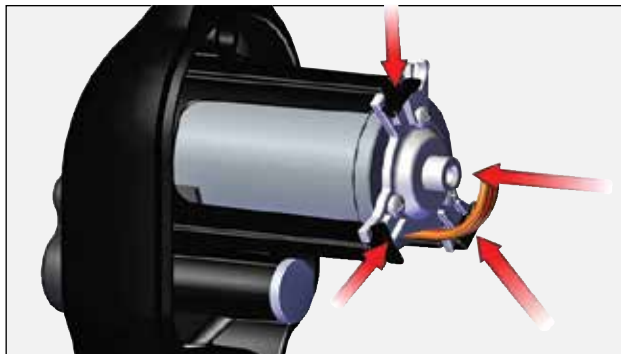

5. Install light pipe.

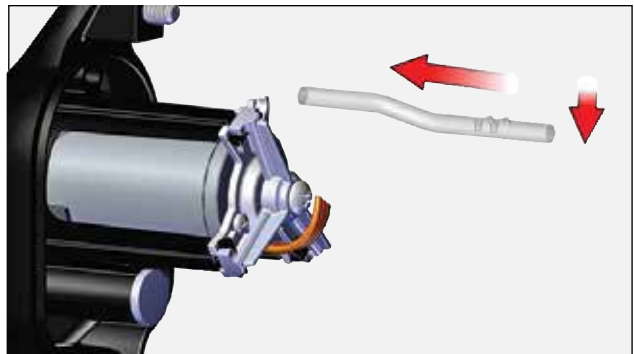

3. Install cartridge then o-ring (if removed).

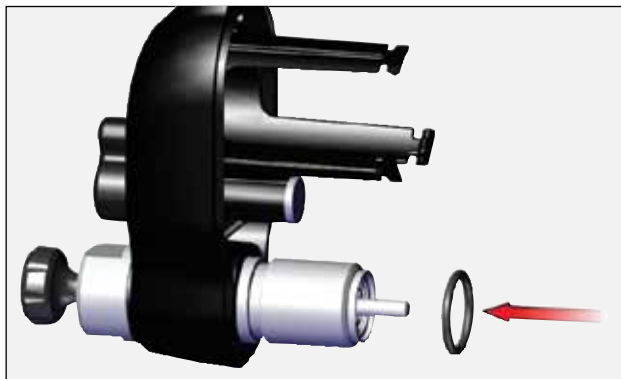

6. Install fluid valve cartridge.

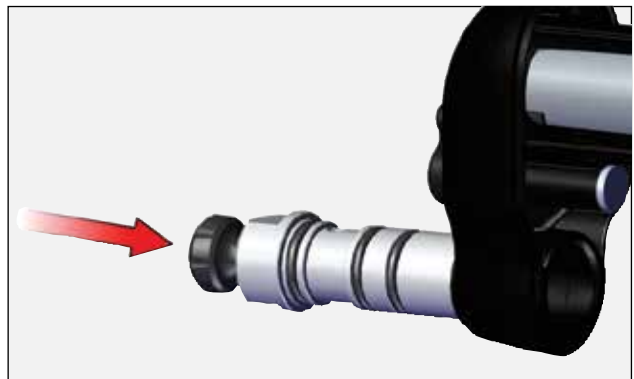



7. Install gasket and re-connect motor connector to handle harness connector.

**NOTE**

➤ This gasket should be replaced each time the rear cover is dis-assembled.

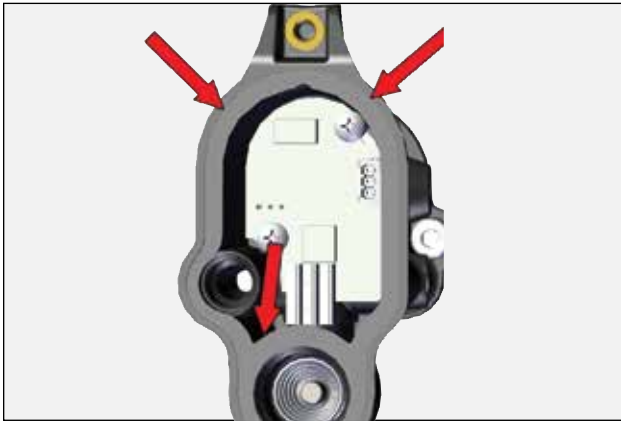

8. Push rear cover assembly into handle and tighten cartridge.

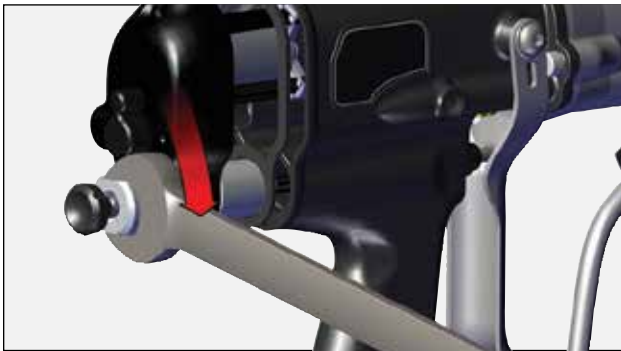

9. Install fan air valve cartridge.



10. Tighten cover screw.



### Air Valve Remove/Replace

1. Remove trigger.
2. Remove rear cover assembly.
3. Remove air valve and spring.

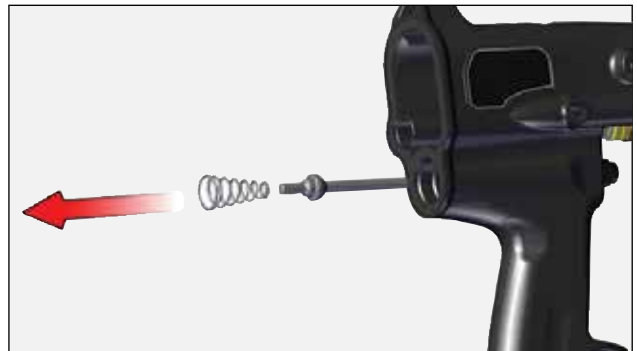

4. Remove air valve packing nut and packing.





5. Insert air valve and spring.



6. Tighten packing nut till light drag is felt on the shaft while moving it back and forth.

7. Install rear cover assembly.

8. Install trigger.

### Fluid Bracket Removal

1. Loosen fluid nut.



2. Remove air fitting.

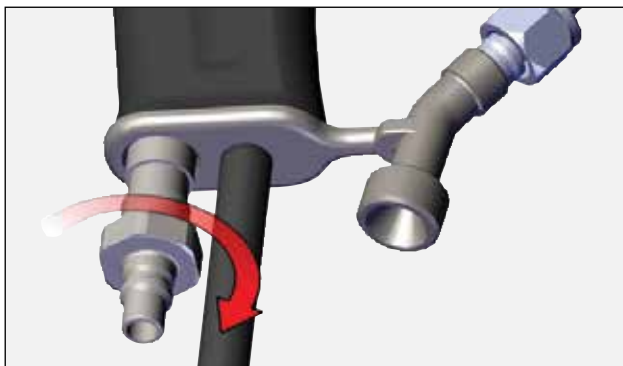

3. Remove bracket, gasket and o-ring.

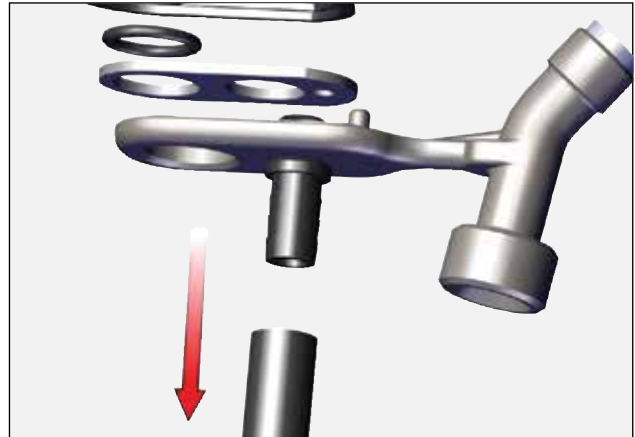

4. Install o-ring, gasket and bracket.

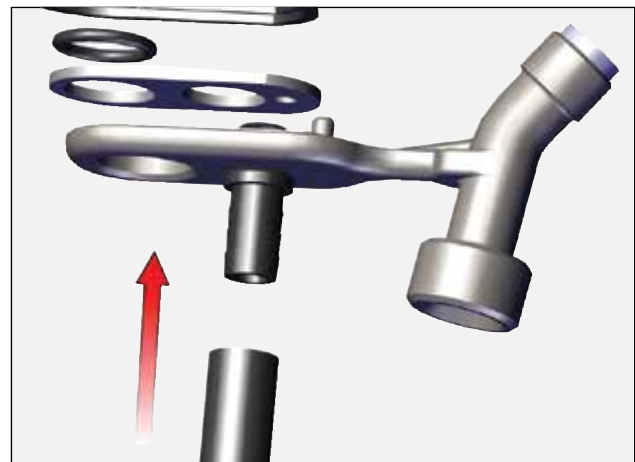

5. Install air fitting.

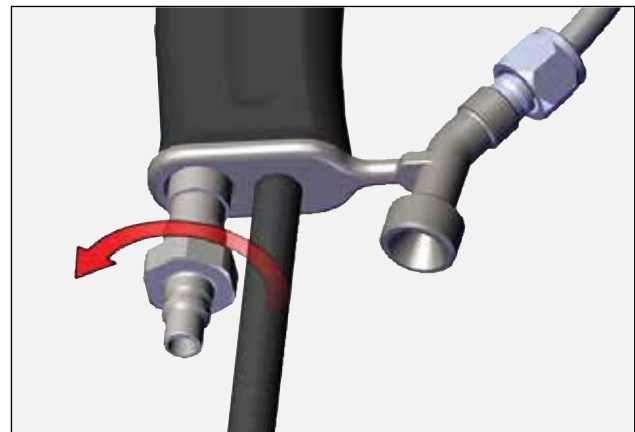



6. Tighten fluid nut.



3. Remove lower fluid nut.



### Gun Wrench Functions 80353-00

1. Adjust packings.

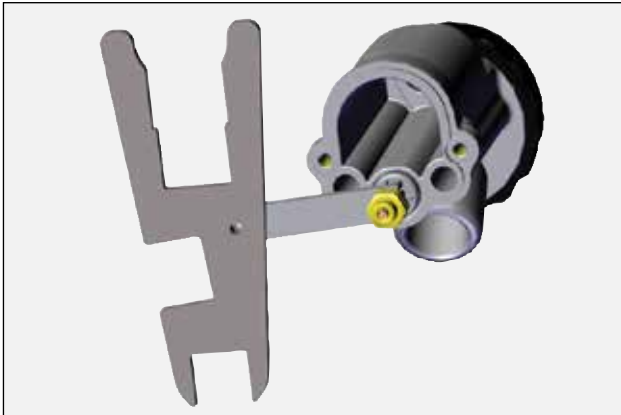

2. Remove nozzles

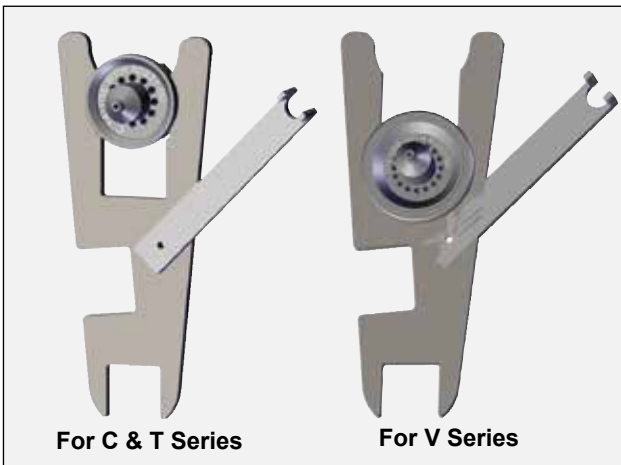

4. Air fitting.

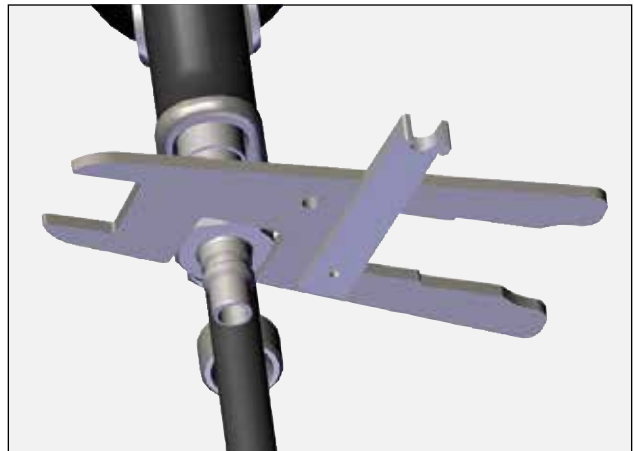

5. Remove rear cartridge.

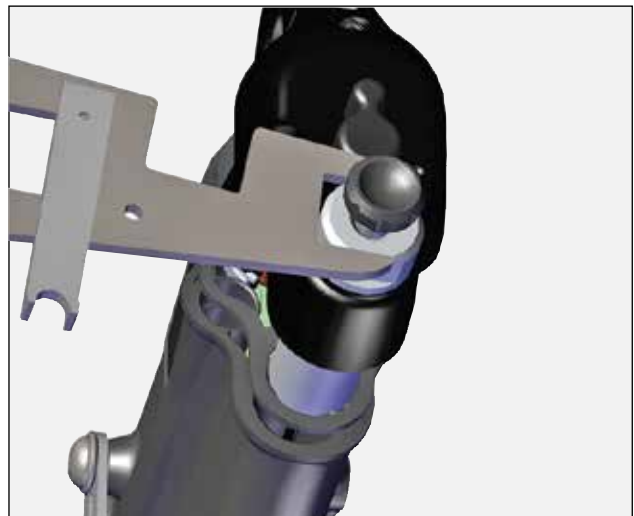



# TROUBLESHOOTING GUIDE



General Problem	Possible Cause	Solution
<b>ELECTRICAL</b>		
<b>No kV</b>	On-Off lever in wrong position	Ensure the On/Off lever is in the On position.
	Low pressure	Ensure 2.8 bar (40 psig) at the applicator handle with applicator triggered.
	No ground connection	Ensure the air hose is properly grounded to the earth ground.
	Cascade not functioning	Ensure cascade is functioning properly, swap parts as required.
	Failed motor function	Ensure motor is properly functioning.
	Too conductive paint	Ensure paint resistance > .1 Meg Ohm
<b>Low kV</b>	Fluid remnants in the air passage	a. Clean air passage with non-polar solvent. b. Ensure fluid nozzle is properly tightened.
	Wrong solvent used for final cleaning process.	Use non-polar solvent for the final cleaning process.
	Add sufficient air pressure at handle	Ensure 2.8 bar (40 psig) at the handle with applicator triggered.
<b>INADEQUATE DELIVERY</b>		
<b>No Fluid Flow</b>	No pressure	Ensure pressure at the fluid line at the applicator.
	Fluid tube may be plugged	Replace or clean.
	Fluid nozzle may be plugged	Replace or clean.
	Electrode not properly assembled	Reassemble tightened to stop.
	Material too viscous	Thin the material to a viscosity that is sprayable
<b>Spray Performance</b>	No adjustment of fan pattern	a. Restrictor missing. Insure restrictor is in place. b. Fluid nozzle tightened too tight. Tighten nozzle till it seats on the barrel o-ring then an additional 1/8 turn
	Poor atomization	Ensure atomization air passages are clear of all foreign particles.
	Fluid in air passages	Ensure fluid nozzle is properly tightened.
	Spits	Ensure air before fluid is properly adjusted.



# PARTS IDENTIFICATION

## RANSFLEX RXI - INDIRECT CHARGE WATERBASE

**80445 - ABCDEF**

Base  
Model No.

Optional  
Designations

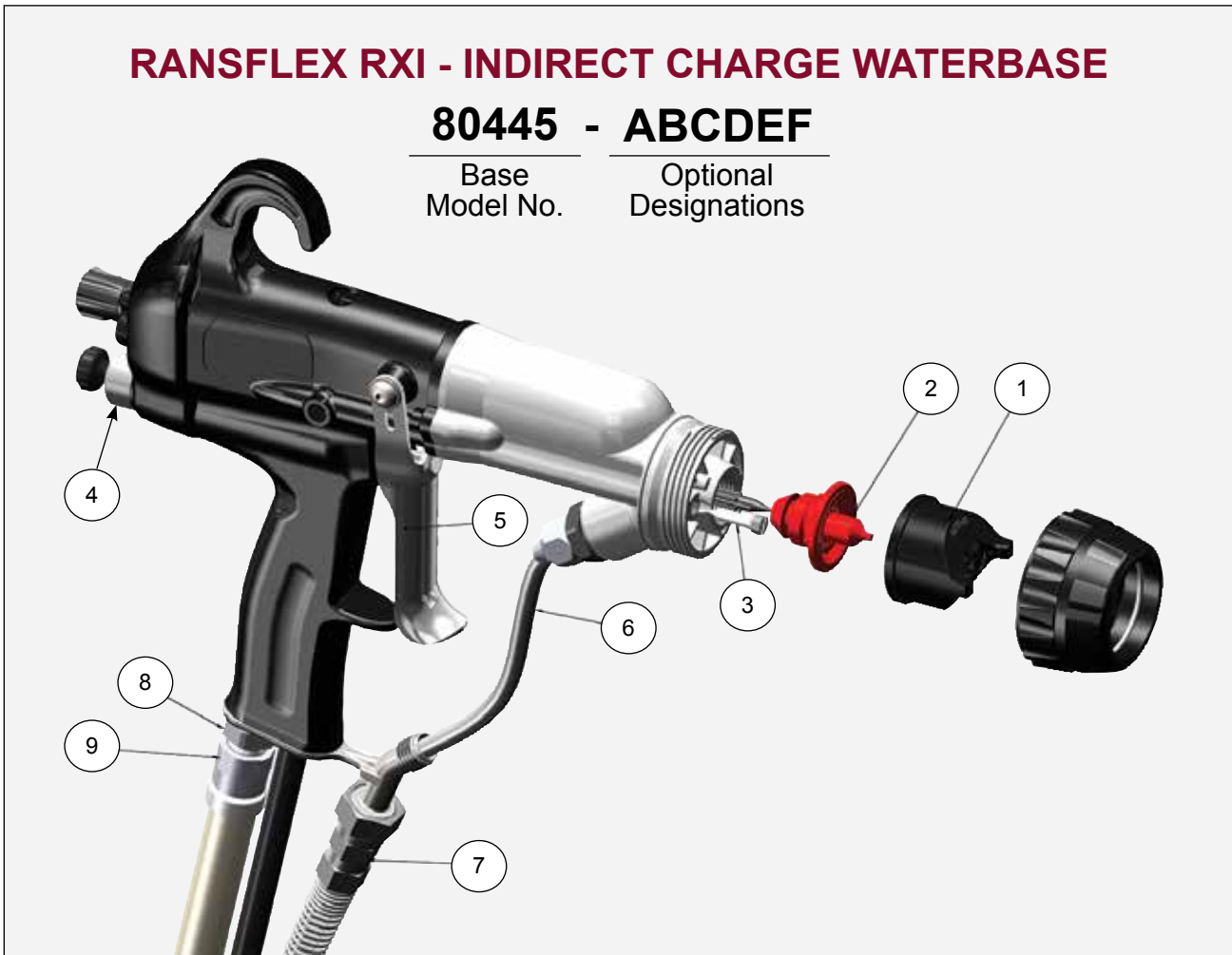

\* **NOTE:** All nozzles available in kits of 3.

### ATOMIZATION - TABLE OF "A" DASHES

"A" Dash No.	"A" Description	"1"	"2"	"3" / Color
0	T SERIES 1.2mm	80383-00	80239-12	74963-05 / BLACK
1	T SERIES 1.4mm	80383-00	80239-14	74963-05 / BLACK
2	T SERIES 1.8mm	80383-00	80239-18	74963-05 / BLACK
3	T SERIES 1.0mm	80383-00	80239-10	74963-05 / BLACK
4	T SERIES 0.7mm	80383-00	80239-07	74963-05 / BLACK

### FLUID CONTROL - TABLE OF "B" DASHES

"B" Dash No.	"B" Description	"4"
1	ADJUSTABLE FLUID	80262-00
2	NON-ADJUSTABLE FLUID	80262-01



**TRIGGER - TABLE OF "C" DASHES**

"C" Dash No.	"C" Description	"5"
1	2 FINGER TRIGGER	80211-00
2	4 FINGER TRIGGER	80386-00*

**FLUID INLET - TABLE OF "D" DASHES**

"D" Dash No.	"D" Description	"6"
1	STD FLUID INLET TUBE	80269-45

**FLUID HOSE - TABLE OF "E" DASHES**

"E" Dash No.	"E" Description	"7"
0	NO FLUID HOSE	---
1	FLUID HOSE, 10m	80303-10
2	FLUID HOSE, 15m	80303-15
3	FLUID HOSE, 20m	80303-20
4	FLUID HOSE, 30m	80303-30

**AIR HOSE - TABLE OF "F" DASHES**

"F" Dash No.	"F" Description	"8"	"9"
0	NO AIR HOSE, STANDARD	80236-00	---
1	STANDARD AIR HOSE, 10m	80236-00	79727-10
2	STANDARD AIR HOSE, 15m	80236-00	79727-15
3	STANDARD AIR HOSE, 20m	80236-00	79727-20
4	STANDARD AIR HOSE, 30m	80236-00	79727-30
5	NO AIR HOSE, QD	80302-00	---
6	QD AIR HOSE, 10m	80302-00	79727-11
7	QD AIR HOSE, 15m	80302-00	79727-16
8	QD AIR HOSE, 20m	80302-00	79727-21
9	QD AIR HOSE, 30m	80302-00	79727-31





**Retaining Ring 80532-00**

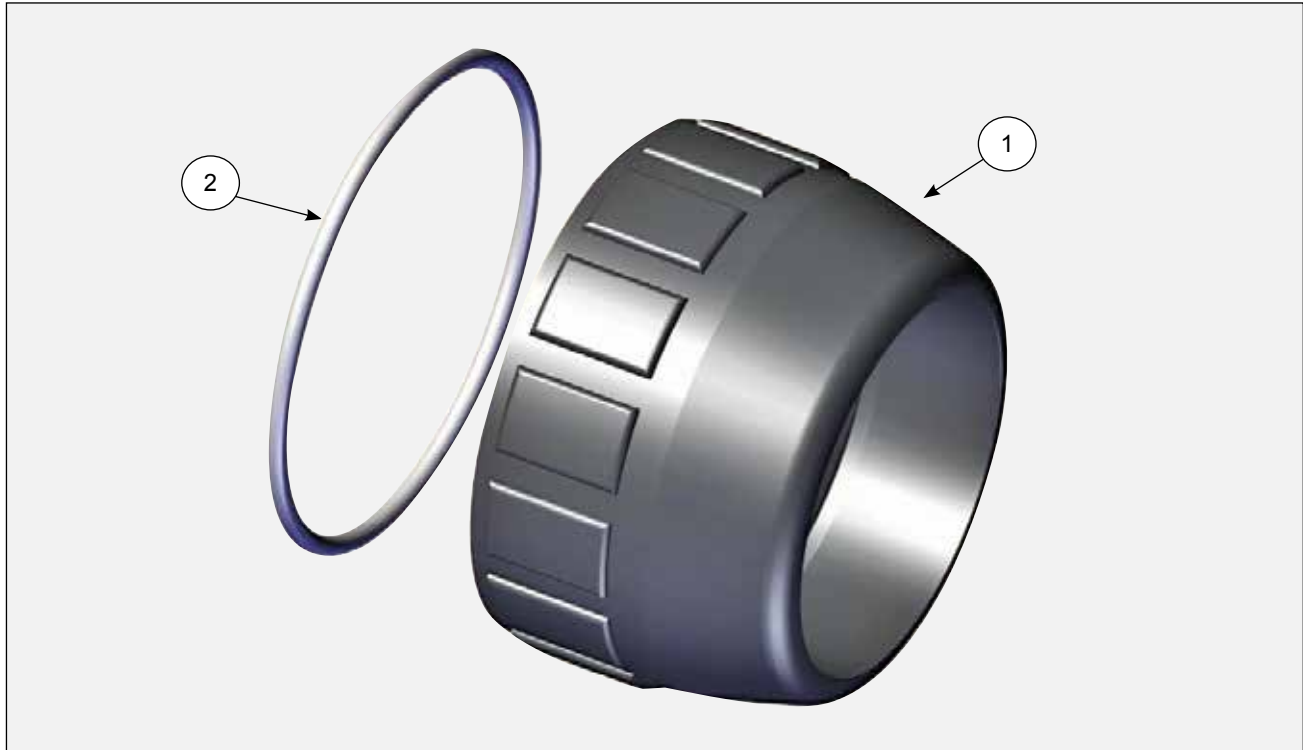

**RETAINING RING 80532-00**

Item No.	Part No.	Description	Qty.
1	80531-00	NUT, RETAINING	1
2	LSOR0005-17	O-RING, ENCAPSULATED	1





**Needle Shaft Assembly 80263-45**

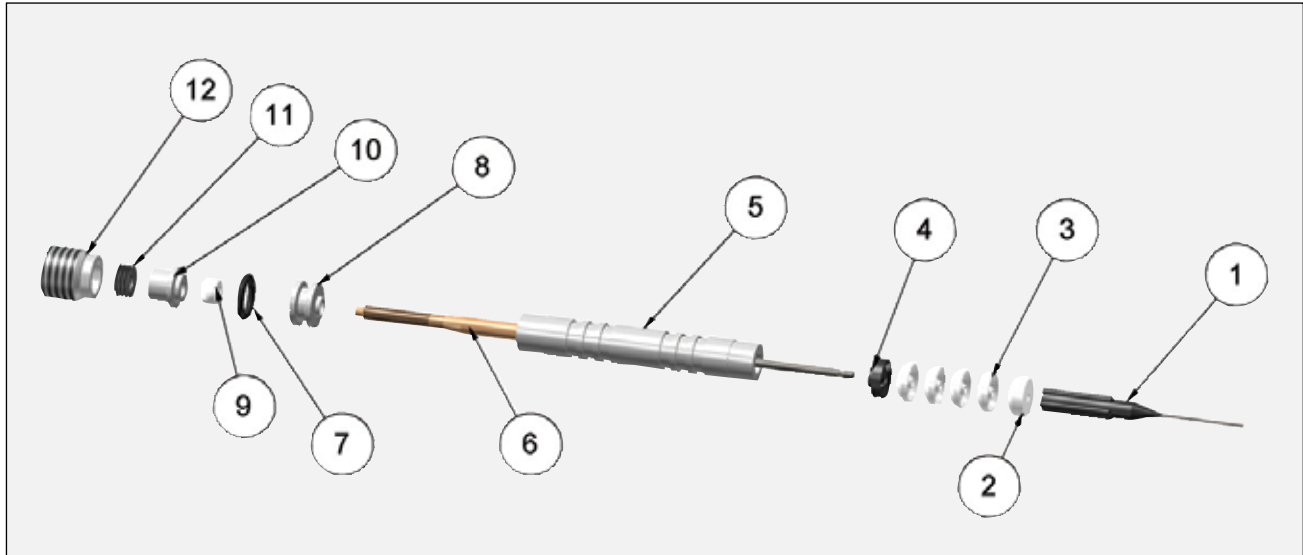

**RXI 45kV NEEDLE SHAFT**

Item No.	Part No.	Description	Qty.
1	70430-01	ASSEMBLY ELECTRODE, HIGH WEAR	1
2	74653-00	ADAPTER, MALE	1
3	14323-00	SEAL, CHEVRON, 3/8 DIA.	4
	14323-00-K4	SEAL, CHEVRON (KIT OF 4)	1
4	18821-00	ADAPTER-FEMALE-CHEVRON	1
5	80257-45	TUBE, PACKING	1
6	80225-45	NEEDLE SHAFT ASSEMBLY	1
7	79001-06	O-RING, SOLVENT PROOF	1
8	78629-00	RETAINER, NEEDLE SEAL, REAR	1
9	10051-05	CUP SEAL, SPRING LOADED	1
10	78630-00	SPACER, SEAL	1
11	17390-04	WASHER, SPRING, BELVILLE	6
	17390-04-K6	WASHER, SPRING, BEVILLE (KIT OF 6)	1
12	78631-00	NUT, PACKING	1



### ITEMS FOR RXI (45KV) UNIT

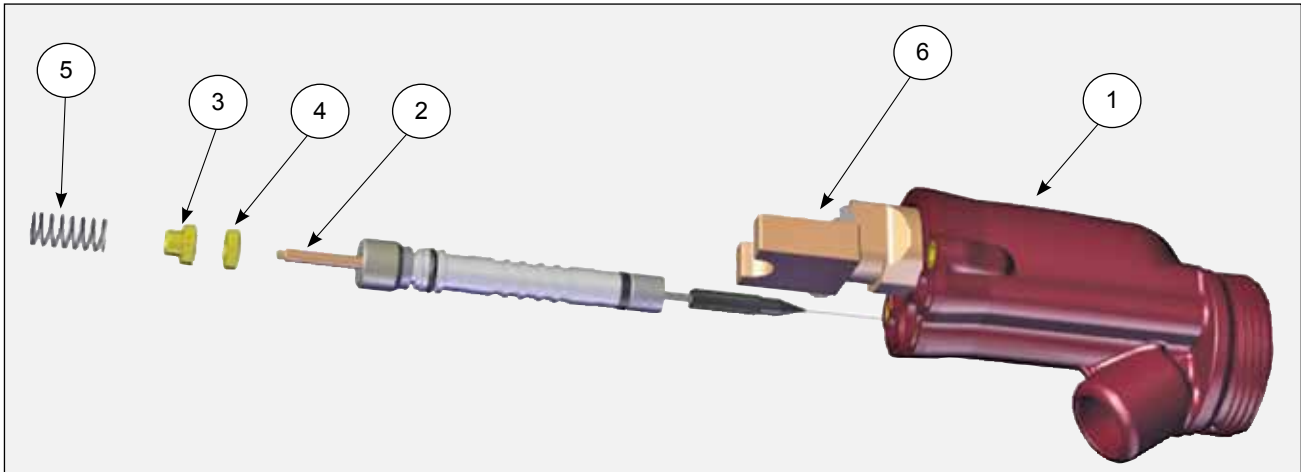

RXI 45kV BARREL			
Item No.	Part No.	Description	Qty.
1	80524-00	ASSEMBLY, BARREL & O-RING	1
2	80263-45	ASSEMBLY, NEEDLE SHAFT	1
3	80242-00	NUT, REAR JAM	1
4	80243-00	NUT, FRONT JAM	1
5	80258-00	SPRING, FLUID RETURN	1
6	80250-45	ASSEMBLY, CASCADE RX (45 kV)	1

#### Barrel and O-Ring P/N 80524-00



RXI 45kV BARREL ONLY			
Item No.	Part No.	Description	Qty.
1	80524-00	BARREL 45Kv (INCLUDES O-RING)	1
2	79001-07	O-RING, SOLVENT PROOF	1



## HANDLE COMPONENTS FOR ALL MODELS



### HANDLE COMPONENTS

Item No.	Part No.	Description	Qty.
1	80375-00	INCLUDES HANDLE (80305-00) AND REAR COVER WITH MOTOR (80378-00) ASSEMBLY (ADJUSTABLE FLUID CONTROL)	1
	80375-01	INCLUDES HANDLE (80305-01) AND REAR COVER WITH MOTOR (80378-00) ASSEMBLY (NON-ADJUSTABLE FLUID CONTROL)	
2	80245-00	GASKET, BARREL	1
3	EMF-201-04	NUT, HEX, NYLON	1
4	EMF-203-04	FERRULE, FRONT 1/4"	2
5	EMF-202-04	FERRULE, BACK 1/4"	2
6	80346-00	NUT, CONNECTOR, HOSE	1
7	80268-00	SCREW, TRIGGER	2
8	80211-00	ASSEMBLY, TRIGGER	1
9	80212-00	BRACKET, FLUID	1
10	80221-00	FITTING, EXHAUST	1
11	80236-00	FITTING, AIR INLET	1
12	80457-00	SEAL, AIR	1
13	80272-00	GASKET, EXHAUST	1
14	79861-00	TUBING, EXHAUST	1



**Handle with Rear Cover with Motor 80375-00/01**

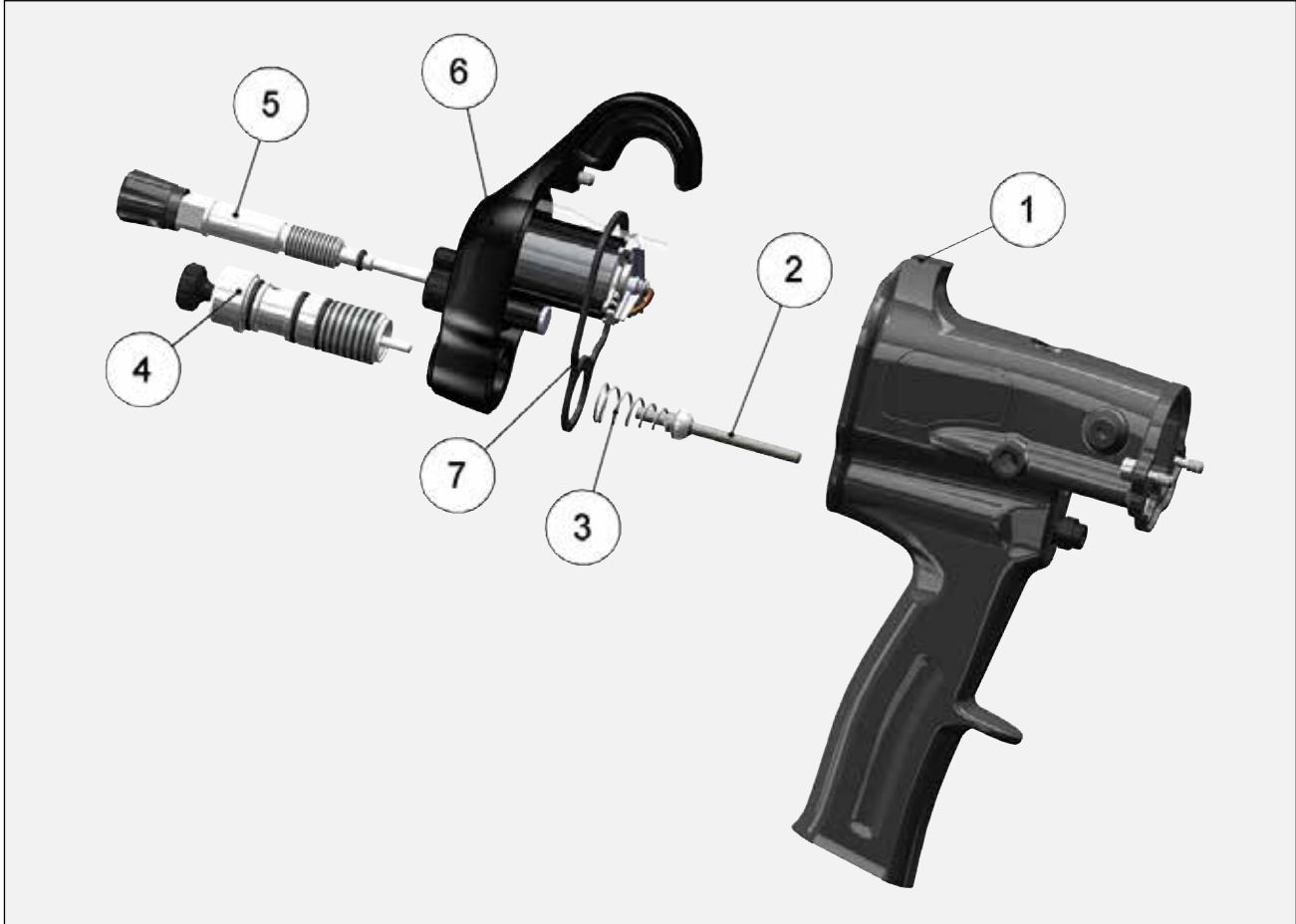

**HANDLE WITH REAR COVER W/MOTOR 80375-00/01**

Item No.	Part No.	Description	Qty.
1	80305-00	ASSEMBLY, HANDLE	1
2	80244-00	ASSEMBLY, VALVE, AIR	1
3	80533-00	SPRING, AIR VALVE	1
4	80262-00	ASSEMBLY, VALVE, ADJUSTABLE FLUID CONTROL	1
	80262-01	ASSEMBLY, VALVE, NON-ADJUSTABLE FLUID CONTROL	1
5	80273-00	ASSEMBLY, VALVE FAN AIR	1
6	80378-00	REAR COVER AND MOTOR ASSEMBLY	1
7	80232-00	GASKET, REAR	1



**Handle Assembly 80305**



**HANDLE ASSEMBLY 80305**

Item No.	Part No.	Description	Qty.
1	80305-00	ASSEMBLY, HANDLE INCLUDES ALL PARTS BELOW, MOTOR CONTROL BOARD AND HARNESSSES	1
2	80274-00	SCREW, BARREL-HANDLE	2
3	80229-00	NUT, RETAINING, AIR VALVE	1
4	10051-05	CUP SEAL, SPRING LOADED	1

**Rear Cartridge Assembly 80262-00 (Adjustable Fluid Control)**

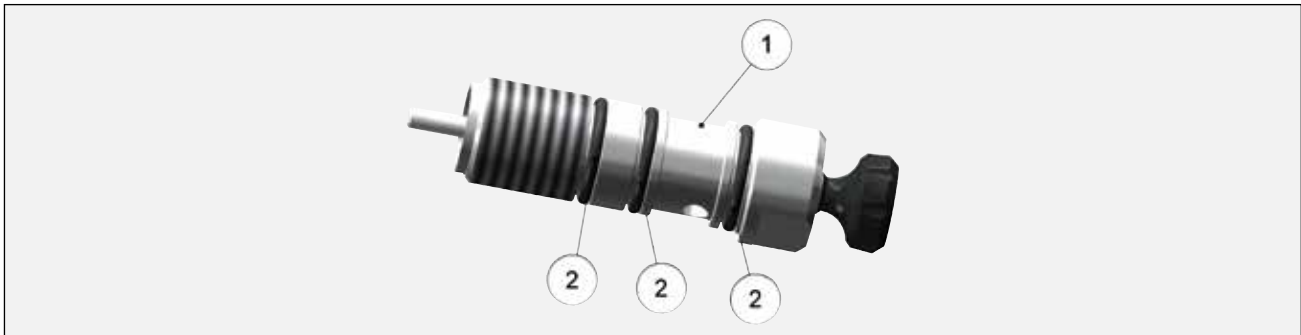

**REAR CARTRIDGE ASSEMBLY 80262-00**

Item No.	Part No.	Description	Qty.
1	80262-00	ASSEMBLY, FLUID CARTRIDGE (INCLUDES ALL PARTS BELOW)	1
2	79001-08	O-RING, SOLVENT PROOF	3



**Rear Cartridge Assembly 80262-01 (Non-Adjustable Fluid Control)**

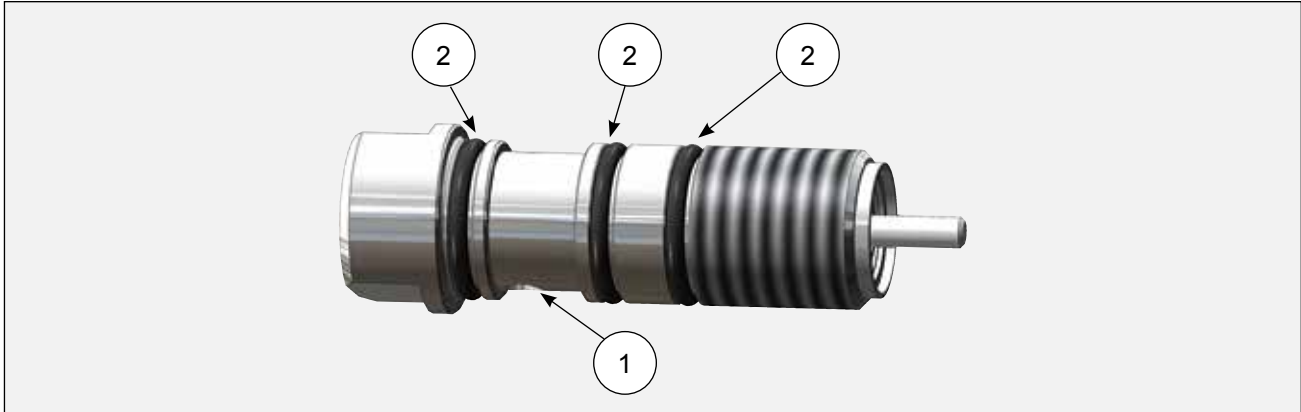

**REAR CARTRIDGE ASSEMBLY 80262-01**

Item No.	Part No.	Description	Qty.
1	80262-01	ASSEMBLY, FLUID CARTRIDGE (NON-ADJUSTABLE)	1
2	79001-08	O-RING, SOLVENT PROOF	3

**80273-00 Fan Air Cartridge**

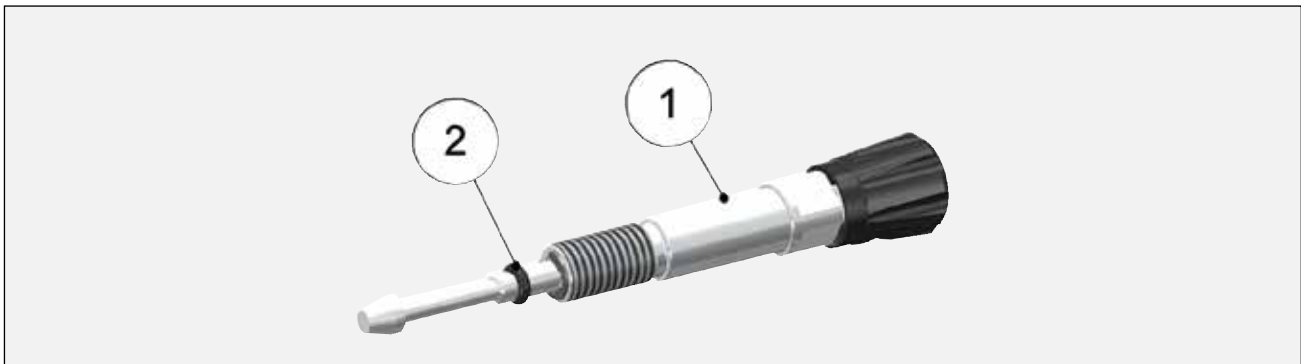

**80273-00 FAN AIR CARTRIDGE**

Item No.	Part No.	Description	Qty.
1	80273-00	ASS'Y., FAN VALVE (INCLUDES ALL PARTS BELOW)	1
2	79001-16	O-RING, SOLVENT PROOF	1



**80378-00 Rear Cover with Motor Assembly**



**80378-00 REAR COVER WITH MOTOR ASSEMBLY**

Item No.	Part No.	Description	Qty.
1	80378-00	COVER, REAR ASSEMBLY (INCLUDES ALL PARTS BELOW)	1
2	80213-00	PIPE, LIGHT	1
3	80255-00	ASSEMBLY, MOTOR	1
4	79775-00	BLOCK, PORTING	1
5	7554-61	O-RING, SOLVENT RESISTANT	1
6	80275-00	SCREW	1
7	80219-00	BRACKET, LOCKING	1



**80255-00 Motor Assembly**

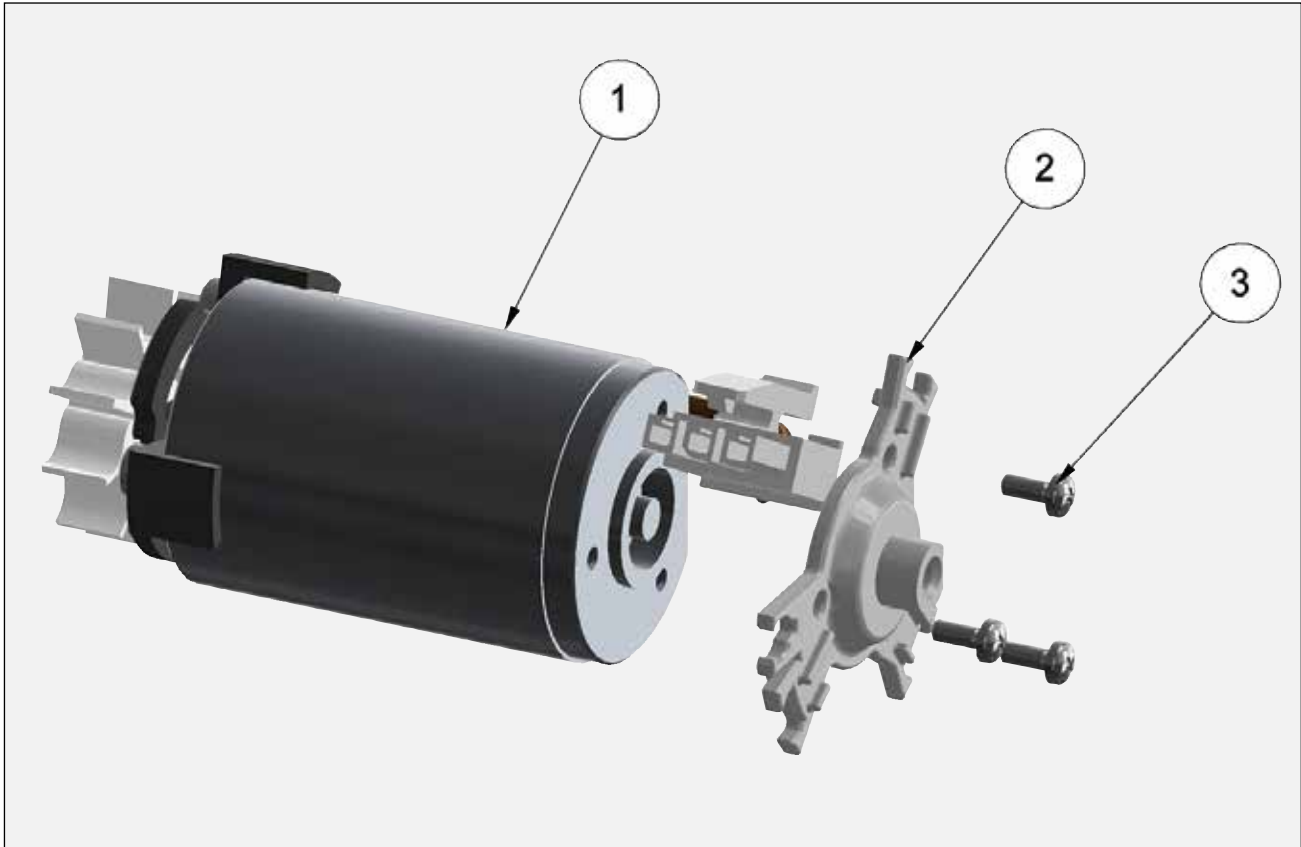

<b>80255-00 MOTOR ASSEMBLY</b>			
<b>Item No.</b>	<b>Part No.</b>	<b>Description</b>	<b>Qty.</b>
1	80255-00	ASSEMBLY, MOTOR (INCLUDES ALL PARTS BELOW)	1
2	80217-00	COVER SUPPORT, MOTOR	1
3	79796-00	SCREW, MOTOR	3





**80254-00 Rear Cover Assembly**

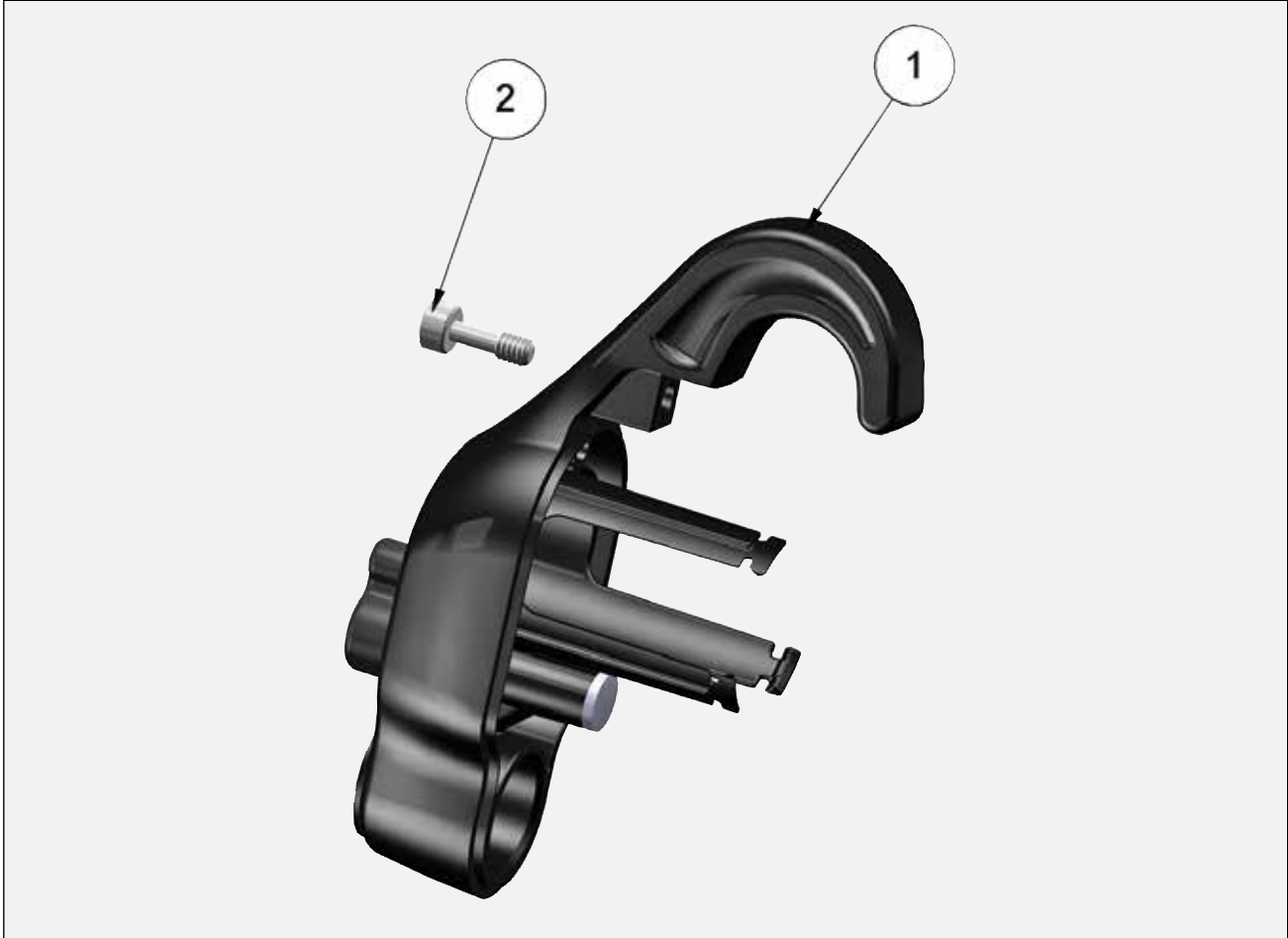

**80254-00 REAR COVER ASSEMBLY**

Item No.	Part No.	Description	Qty.
1	80254-00	COVER, REAR (CONTAINS PARTS BELOW)	1
2	80274-00	M4 X .7 SHCS	1



**ACCESSORIES INCLUDED WITH RX OR RFX**

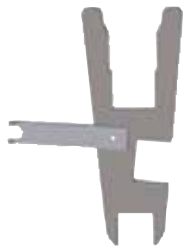

**80353-00 Gun Wrench**



**79862-02 3mm Hex Driver**



**LSCH 0009 Grease**

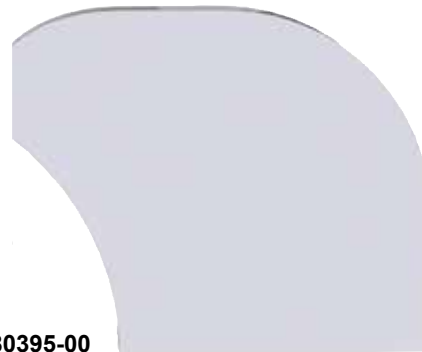

**80395-00**

**SPARE PARTS KITS**

Part #	Description
80548-10	T Series Atomization Kit Contains (1) 80383-00 Air Cap, (2) 80239-10 (1.0 mm) Fluid Nozzle
80548-12	T Series Atomization Kit Contains (1) 80383-00 Air Cap, (2) 80239-12 (1.2 mm) Fluid Nozzle
80548-14	T Series Atomization Kit Contains (1) 80383-00 Air Cap, (2) 80239-14 (1.4 mm) Fluid Nozzle
70430-01-K3	Resistive electrode in kits of 3
80389-00	Gasket kit contains gaskets for Rear Cover/Handle, Handle/Barrel and Handle fluid bracket.
80391-00	All soft parts required to rebuild an applicator
80395-K10	Gun Cover - Kit of 10
80395-K100	Gun Cover - Kit of 100
76633-K5	Conductive Gloves - Kit of 5
76633-K10	Conductive Gloves - Kit of 10

**ACCESSORIES**

Part #	Description
27141-081	Wrap, Spiral
59972-00	Pack of 4 LSCH0009 Grease
76102-00	Applicator Mounting Bracket
76652-01	HV Probe
76652-02	Sprayability and SCI Paint Test Meter
76652-03	Paint Resistivity, Sprayability
76652-04	Deluxe Kit
79727-05	5m Air Hose STD Fitting
79727-06	5m Air Hose OD Fitting



**RECOMMENDED SPARE PARTS**

**RANSFLEX RECOMMENDED SPARE PARTS  
(Quantities Per Applicator)**

Part #	Description	Qty
80239-XX	Nozzle, Fluid T Series (See page 42)	1
80239-XX-K3	Nozzle, Fluid T Series (See page 42) (Kit of 3)	1
80524-00	Assembly, Barrel (RXI Models) (with Front Seal)	1
80250-45	Cascade Assembly (RXI Models)	1
80245-00	Gasket, Barrel	1
80383-00	Air Cap T Series	2
80532-00	Nut, Retaining	1
EMF-201-04	Nut, Hex Nylon	2
EMF-202-04	Ferrule, Back	2
EMF-203-04	Ferrule, Front	2
80268-00	Screw, Trigger Retention	2
80242-00	Nut, Rear, Jam	1
80243-00	Nut, Fluid Jam, Front	1
80255-00	Assembly, Motor	1
80258-00	Spring, Fluid Return	1
70430-01	Electrode	2
70430-01-K3	Kit of 3 Electrodes	1
80232-00	Gasket, Rear	1
80263-45	Shaft Assembly, 2-Piece Needle	1
10051-05	Seal, Air Valve	1
80269-45	Fluid Inlet	1
80272-00	Gasket, Exhaust	1
LSCH0009-00	Dielectric Grease	2
80259-00	Spring, Air Valve	1



# WARRANTY POLICIES

## LIMITED WARRANTY

Ransburg will replace or repair without charge any part and/or equipment that falls within the specified time (see below) because of faulty workmanship or material, provided that the equipment has been used and maintained in accordance with Ransburg's written safety and operating instructions, and has been used under normal operating conditions. Normal wear items are excluded.

### **THE USE OF OTHER THAN RANSBURG APPROVED PARTS, VOID ALL WARRANTIES.**

**SPARE PARTS:** One hundred and eighty (180) days from date of purchase, except for rebuilt parts (any part number ending in "R") for which the warranty period is ninety (90) days.

**EQUIPMENT:** When purchased as a complete unit, (i.e., guns, power supplies, control units, etc.), is one (1) year from date of purchase. **WRAPPING THE APPLICATOR IN PLASTIC, SHRINK-WRAP, ETC., WILL VOID THIS WARRANTY.**

**RANSBURG'S ONLY OBLIGATION UNDER THIS WARRANTY IS TO REPLACE PARTS THAT HAVE FAILED BECAUSE OF FAULTY WORKMANSHIP OR MATERIALS. THERE ARE**

**NO IMPLIED WARRANTIES NOR WARRANTIES OF EITHER MERCHANTABILITY OR FITNESS FOR A PARTICULAR PURPOSE. RANSBURG ASSUMES NO LIABILITY FOR INJURY, DAMAGE TO PROPERTY OR FOR CONSEQUENTIAL DAMAGES FOR LOSS OF GOODWILL OR PRODUCTION OR INCOME, WHICH RESULT FROM USE OR MISUSE OF THE EQUIPMENT BY PURCHASER OR OTHERS.**

### **EXCLUSIONS:**

If, in Ransburg's opinion the warranty item in question, or other items damaged by this part was improperly installed, operated or maintained, Ransburg will assume no responsibility for repair or replacement of the item or items. The purchaser, therefore will assume all responsibility for any cost of repair or replacement and service related costs if applicable.



---

# MANUAL CHANGE SUMMARY

---



Supersedes Service Manual **AH-15-02** with the following changes:

1. Add 2 new nozzels to T SERIES Table — **Page 20**.
2. Insert new copy for cleaning solvents with cautions and warning — **Page 21**.

## **Manufacturing**

1910 North Wayne Street  
Angola, Indiana 46703-9100  
Telephone: 260-665-8800  
Fax: 260-665-8516

## **Technical Service — Assistance**

320 Philips Ave.  
Toledo, Ohio 43612-1493  
Telephone (toll free): 800-233-3366  
Fax: 419-470-2233

**Technical Support Representative will direct you to the appropriate telephone number for ordering Spare Parts.**

Form No. AH-15-02.1  
Litho in U.S.A.  
02/16

© 2016 Carlisle Fluid Technologies, dba Finishing Brands  
All rights reserved. Models and specifications subject to change without notice.

