

EVOLVER SE ROBOTIC ATOMIZERS

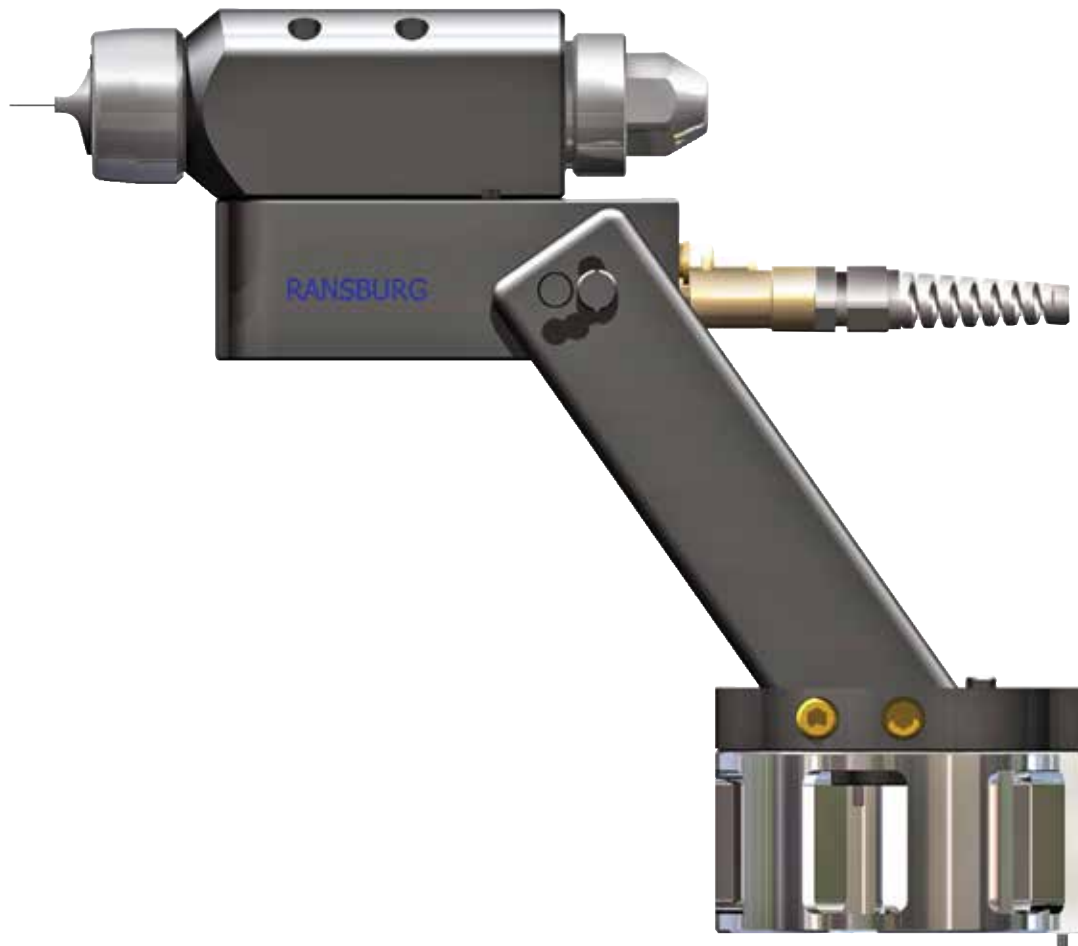

MODEL: A13901-XXXXXXXX

IMPORTANT: Before using this equipment, carefully read SAFETY PRECAUTIONS, starting on page 1, and all instructions in this manual. Keep this Service Manual for future reference.

Service Manual Price: \$50.00 (U.S.)

CONTENTS

	PAGE
SAFETY:	1-5
SAFETY PRECAUTIONS	1
HAZARDS / SAFEGUARDS	2-5
INTRODUCTION:	6-10
SPECIFICATIONS	6
FEATURES.....	7
EVOLVER SE APPLICATOR MODEL IDENTIFICATION.....	8-10
INSTALLATION:	11-15
GENERAL INFORMATION	11-13
POWER SUPPLY CONNECTIONS	14-15
OPERATION:	16-18
GENERAL GUIDELINES	16-17
EVOLVER SE GUN CONTROLS - FLUID VALVE / TRIGGER	17
EVOLVER SE GUN CONTROLS - AIR	17-18
LVMP	18
EVOLVER SE GUN CONTROLS - MECHANICALLY TIMED TRIGGER.....	18
MAINTENANCE:	19-26
ROUTINE MAINTENANCE SCHEDULE	19-20
APPLICATOR CLEANING.....	21-26
SERVICE:	27-64
PROPER TOOLS	28
SPRAY HEAD ASSEMBLY	29
SPRAY HEAD DISASSEMBLY.....	30-42
SPRAY HEAD REASSEMBLY.....	43-57
SPRAY HEAD ASSEMBLY - INSTALLATION.....	58
GUN HEAD IDENTIFICATION	59
TOOL CENTER POINT DRAWINGS.....	60-64
PARTS IDENTIFICATION:	65-80
EVOLVER SE COMPLETE ASSEMBLY	65
EVOLVER SE MODEL IDENTIFICATION.....	66-68
EVOLVER SE PARTS LIST.....	69
SPRAY HEAD ASSEMBLY	70-72
DUMP MANIFOLD PARTS IDENTIFICATION	73
HIGH VOLTAGE CABLE SELECTION PARTS IDENTIFICATION.....	74
RECOMMENDED SPARE PARTS.....	75-76

(Continued On Next Page)

CONTENTS (Cont.)

	PAGE
PARTS IDENTIFICATION (Cont.)	65-80
REPAIR KITS	77
LUBRICANTS AND SEALERS.....	77
80202 TRANS-TECH KIT	78
80374 EVOLVER BARE SPRAY HEAD ASSEMBLY	78
SPRAY APPLICATOR COVERS	79
TEST AIR CAPS AND GAUGE ASSEMBLY.....	79
TROUBLESHOOTING GUIDE	80
WARRANTY POLICIES:	81
LIMITED WARRANTY	81

SAFETY

SAFETY PRECAUTIONS

Before operating, maintaining or servicing any Ransburg electrostatic coating system, read and understand all of the technical and safety literature for your Ransburg products. This manual contains information that is important for you to know and understand. This information relates to USER SAFETY and PREVENTING EQUIPMENT PROBLEMS. To help you recognize this information, we use the following symbols. Please pay particular attention to these sections.

A WARNING! states information to alert you to a situation that might cause serious injury if instructions are not followed.

A CAUTION! states information that tells how to prevent damage to equipment or how to avoid a situation that might cause minor injury.

A NOTE is information relevant to the procedure in progress.

While this manual lists standard specifications and service procedures, some minor deviations may be found between this literature and your equipment. Differences in local codes and plant requirements, material delivery requirements, etc., make such variations inevitable. Compare this manual with your system installation drawings and appropriate Ransburg equipment manuals to reconcile such differences.

Careful study and continued use of this manual will provide a better understanding of the equipment and process, resulting in more efficient operation, longer trouble-free service and faster, easier troubleshooting. If you do not have the manuals and safety literature for your Ransburg system, contact your local Ransburg representative or Ransburg.



WARNING

- The user **MUST** read and be familiar with the Safety Section in this manual and the Ransburg safety literature therein identified.
- This equipment is intended to be used by trained personnel **ONLY**.
- This manual **MUST** be read and thoroughly understood by **ALL** personnel who operate, clean or maintain this equipment! Special care should be taken to ensure that the **WARNINGS** and safety requirements for operating and servicing the equipment are followed. The user should be aware of and adhere to ALL local building and fire codes and ordinances as well as **NFPA-33 AND EN 50176 SAFETY STANDARDS, LATEST EDITION, or applicable country safety standards**, prior to installing, operating, and/or servicing this equipment.

WARNING

- The hazards shown on the following pages may occur during the normal use of this equipment. Please read the hazard chart beginning on page 2.

<p>AREA Tells where hazards may occur.</p>	<p>HAZARD Tells what the hazard is.</p>	<p>SAFEGUARDS Tells how to avoid the hazard.</p>
<p>Spray Area</p> 	<p>Fire Hazard</p> <p>Improper or inadequate operation and maintenance procedures will cause a fire hazard.</p> <p>Protection against inadvertent arcing that is capable of causing fire or explosion is lost if any safety interlocks are disabled during operation. Frequent Power Supply or Controller shutdown indicates a problem in the system requiring correction.</p>	<p>Fire extinguishing equipment must be present in the spray area and tested periodically.</p> <p>Spray areas must be kept clean to prevent the accumulation of combustible residues.</p> <p>Smoking must never be allowed in the spray area.</p> <p>The high voltage supplied to the atomizer must be turned off prior to cleaning, flushing or maintenance.</p> <p>When using solvents for cleaning:</p> <ul style="list-style-type: none"> • Those used for equipment flushing should have flash points equal to or higher than those of the coating material. • Those solvents used for general cleaning must have a flash point at minimum of 15°C (27°F) greater than the ambient temperature. It is the end user's responsibility to insure this condition is met. <p>Spray booth ventilation must be kept at the rates required by NFPA-33, OSHA, country, and local codes. In addition, ventilation must be maintained during cleaning operations using flammable or combustible solvents.</p> <p>Electrostatic arcing must be prevented. Safe sparking distance must be maintained between the parts being coated and the applicator. A distance of 1 inch for every 10KV of output voltage is required at all times.</p> <p>Test only in areas free of combustible material. Testing may require high voltage to be on, but only as instructed.</p> <p>Non-factory replacement parts or unauthorized equipment modifications may cause fire or injury. If used, the key switch bypass is intended for use only during setup operations. Production should never be done with safety interlocks disabled.</p> <p>Never use equipment intended for use in waterborne installations to spray solvent based materials.</p> <p>The paint process and equipment should be set up and operated in accordance with NFPA-33, NEC, OSHA, local, country, and European Health and Safety Norms.</p>

<p>AREA Tells where hazards may occur.</p>	<p>HAZARD Tells what the hazard is.</p>	<p>SAFEGUARDS Tells how to avoid the hazard.</p>
<p>Spray Area</p> 	<p>Explosion Hazard</p> <p>Improper or inadequate operation and maintenance procedures will cause a fire hazard.</p> <p>Protection against inadvertent arcing that is capable of causing fire or explosion is lost if any safety interlocks are disabled during operation.</p> <p>Frequent Power Supply or Controller shutdown indicates a problem in the system requiring correction.</p>	<p>Electrostatic arcing must be prevented. Safe sparking distance must be maintained between the parts being coated and the applicator. A distance of 1 inch for every 10KV of output voltage is required at all times.</p> <p>Unless specifically approved for use in hazardous locations, all electrical equipment must be located outside Class I or II, Division 1 or 2 hazardous areas, in accordance with NFPA-33.</p> <p>Test only in areas free of flammable or combustible materials.</p> <p>The current overload sensitivity (if equipped) MUST be set as described in the corresponding section of the equipment manual. Protection against inadvertent arcing that is capable of causing fire or explosion is lost if the current overload sensitivity is not properly set. Frequent power supply shutdown indicates a problem in the system which requires correction.</p> <p>Always turn the control panel power off prior to flushing, cleaning, or working on spray system equipment.</p> <p>Before turning high voltage on, make sure no objects are within the safe sparking distance.</p> <p>Ensure that the control panel is interlocked with the ventilation system and conveyor in accordance with NFPA-33, EN 50176.</p> <p>Have fire extinguishing equipment readily available and tested periodically.</p>
<p>General Use and Maintenance</p> 	<p>Improper operation or maintenance may create a hazard.</p> <p>Personnel must be properly trained in the use of this equipment.</p>	<p>Personnel must be given training in accordance with the requirements of NFPA-33, EN 60079-0.</p> <p>Instructions and safety precautions must be read and understood prior to using this equipment.</p> <p>Comply with appropriate local, state, and national codes governing ventilation, fire protection, operation maintenance, and housekeeping. Reference OSHA, NFPA-33, EN Norms and your insurance company requirements.</p>

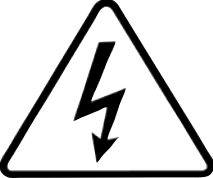
<p>AREA Tells where hazards may occur.</p>	<p>HAZARD Tells what the hazard is.</p>	<p>SAFEGUARDS Tells how to avoid the hazard.</p>
<p>Spray Area / High Voltage Equipment</p> 	<p>Electrical Discharge</p> <p>There is a high voltage device that can induce an electrical charge on ungrounded objects which is capable of igniting coating materials.</p> <p>Inadequate grounding will cause a spark hazard. A spark can ignite many coating materials and cause a fire or explosion.</p>	<p>Parts being sprayed and operators in the spray area must be properly grounded.</p> <p>Parts being sprayed must be supported on conveyors or hangers that are properly grounded. The resistance between the part and earth ground must not exceed 1 meg ohm. (Refer to NFPA-33.)</p> <p>Operators must be grounded. Rubber soled insulating shoes should not be worn. Grounding straps on wrists or legs may be used to assure adequate ground contact.</p> <p>Operators must not be wearing or carrying any ungrounded metal objects.</p> <p>When using an electrostatic handgun, operators must assure contact with the handle of the applicator via conductive gloves or gloves with the palm section cut out.</p> <p>NOTE: REFER TO NFPA-33 OR SPECIFIC COUNTRY SAFETY CODES REGARDING PROPER OPERATOR GROUNDING.</p> <p>All electrically conductive objects in the spray area, with the exception of those objects required by the process to be at high voltage, must be grounded. Grounded conductive flooring must be provided in the spray area.</p> <p>Always turn off the power supply prior to flushing, cleaning, or working on spray system equipment.</p> <p>Unless specifically approved for use in hazardous locations, all electrical equipment must be located outside Class I or II, Division 1 or 2 hazardous areas, in accordance with NFPA-33.</p> <p>Avoid installing an applicator into a fluid system where the solvent supply is ungrounded.</p> <p>Do not touch the applicator electrode while it is energized.</p>

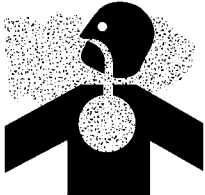
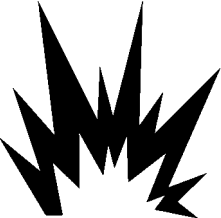
<p>AREA Tells where hazards may occur.</p>	<p>HAZARD Tells what the hazard is.</p>	<p>SAFEGUARDS Tells how to avoid the hazard.</p>
<p>Electrical Equipment</p> 	<p>Electrical Discharge</p> <p>High voltage equipment is utilized in the process. Arcing in the vicinity of flammable or combustible materials may occur. Personnel are exposed to high voltage during operation and maintenance.</p> <p>Protection against inadvertent arcing that may cause a fire or explosion is lost if safety circuits are disabled during operation.</p> <p>Frequent power supply shut-down indicates a problem in the system which requires correction.</p> <p>An electrical arc can ignite coating materials and cause a fire or explosion.</p>	<p>Unless specifically approved for use in hazardous locations, the power supply, control cabinet, and all other electrical equipment must be located outside Class I or II, Division 1 and 2 hazardous areas in accordance with NFPA-33 and EN 50176.</p> <p>Turn the power supply OFF before working on the equipment.</p> <p>Test only in areas free of flammable or combustible material.</p> <p>Testing may require high voltage to be on, but only as instructed.</p> <p>Production should never be done with the safety circuits disabled.</p> <p>Before turning the high voltage on, make sure no objects are within the sparking distance.</p>
<p>Toxic Substances</p> 	<p>Chemical Hazard</p> <p>Certain materials may be harmful if inhaled, or if there is contact with the skin.</p>	<p>Follow the requirements of the Safety Data Sheet supplied by coating material manufacturer.</p> <p>Adequate exhaust must be provided to keep the air free of accumulations of toxic materials.</p> <p>Use a mask or respirator whenever there is a chance of inhaling sprayed materials. The mask must be compatible with the material being sprayed and its concentration. Equipment must be as prescribed by an industrial hygienist or safety expert, and be NIOSH approved.</p>
<p>Spray Area</p> 	<p>Explosion Hazard — Incompatible Materials</p> <p>Halogenated hydrocarbon solvents for example: methylene chloride and 1,1,1,-Trichloroethane are not chemically compatible with the aluminum that might be used in many system components. The chemical reaction caused by these solvents reacting with aluminum can become violent and lead to an equipment explosion.</p>	<p>Spray applicators require that aluminum inlet fittings be replaced with stainless steel.</p> <p>Aluminum is widely used in other spray application equipment - such as material pumps, regulators, triggering valves, etc. Halogenated hydrocarbon solvents must never be used with aluminum equipment during spraying, flushing, or cleaning. Read the label or data sheet for the material you intend to spray. If in doubt as to whether or not a coating or cleaning material is compatible, contact your coating supplier. Any other type of solvent may be used with aluminum equipment.</p>

INTRODUCTION

The Evolver SE is an automatic robot mounted spray applicator capable of spraying solvent borne or waterborne coatings electrostatically or non-electrostatically. It incorporates a unique 1/3 turn quick disconnect spray head. The spray head and valve manifold contain fluid and air passages. All fluid passages contain stainless steel and/or plastic fittings, compatible with halogenated hydrocarbon solvents.

SPECIFICATIONS

Environmental/Physical

Robot / Mounting Compatibility:

All non-hollow and hollow wrist robots, Paint Mate, reciprocator and stationary stands.

Operating Voltage:

85 kV maximum with 9060 or Voltage Master power supply.

Operating Temperature Range:

55°F (12.8 °C) to 131°F (55°C)

Weight:

SE with gun, manifold and bracket = 3.35 lbs (1.52 kg) max.
SE with gun, manifold, dump block and bracket = 3.60 lbs (1.64 kg) max.

Length:

Dependent on configuration
(see configuration drawings)

Paint Flow Rate:

Variable to 500 cc/min.
(Depending on viscosity and configuration)

Trigger Response Time:

150 msec. OPEN
220 msec. CLOSED

Operating Air Pressures:

Atomizing Air: 100 psig max. (6.9 bar)
Fan Air: 100 psig max. (6.9 bar)
Trigger Air: 70 psig min. - 100 psig max. (4.8 - 6.9 bar)
Dump Pilot: 70 psig min. - 100 psig max. (4.8 - 6.9 bar)
Operating Fluid Pressure: 100 psig max. (6.9 bar)

Tubing Requirements:

Atomizing Air: 5/16" (8mm) OD Nylon
Fan Air: 5/16" (8mm) OD Nylon
Trigger Air: 5/32" (4mm) OD Nylon
Dump Pilot: 5/32" (4mm) OD Nylon
Fluid (PTFE): 5/16" (8mm) non-shielded
Fluid (optional): 3/8" OD shielded (for waterborne or highly conductive materials)
Dump (PTFE): 5/16" (8mm)

Robot Wrist Movement:

Axis 6 limit to 430°

FEATURES

The features of the Evolver SE applicator includes:

- Quick disconnect spray head.
- High quality Ransburg air cap and fluid nozzle.
- Dual start, dual pitch air cap retaining ring.
- Bleed or non-bleed option.
- Internal fan and atomization air control valve, with a mechanically timed trigger sequence.
- Adaptable to any robot mounting configuration.
- Adjustable angle spray head.
- Dump valve version available.



Evolver SE With Dump Valve



Evolver SE With "Dead Head" or Recirculation Manifold



EVOLVER SE - APPLICATOR MODEL IDENTIFICATION

When ordering, use A13901-AABCDEFGG as indicated by Tables AA, B, C, D, E, F and G.
Eight (8) digits must follow the basic part number. For Example:

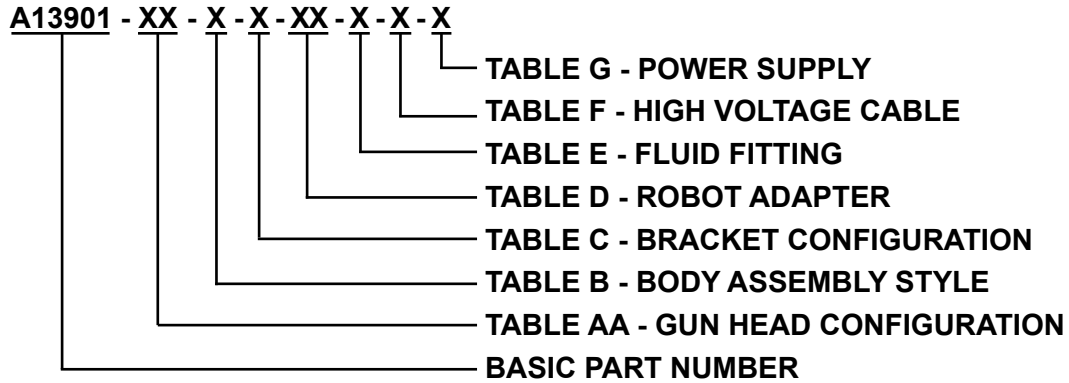

TABLE AA - GUN HEAD CONFIGURATION		
Dash #	“C”	Description
00	---	NONE
01	A13856-01	CONVENTIONAL/NON-BLEED SPRAY GUN HEAD (.055” TIP, 1.4MM)
03	A13856-03	CONVENTIONAL BLEED SPRAY GUN HEAD (.055” TIP, 1.4MM)
21	A13856-21	TRANS-TECH/BLEED SPRAY GUN HEAD (.055” TIP, 1.4MM)
22	A13856-22	TRANS-TECH/NON-BLEED SPRAY GUN HEAD (.055” TIP, 1.4MM)

TABLE B - BODY ASSEMBLY STYLE				
Dash #	“A”	“B”	“E”	Description
0	---	---	---	NONE
1	A13867-01	1	1	NON-RECIRCULATING BODY ASSEMBLY
2	A13868-02	2	1	RECIRCULATING BODY ASSEMBLY
3	A13873-00	1	2	NON-RECIRCULATING BODY ASSEMBLY WITH DUMP VALVE BLOCK

TABLE C - BRACKET CONFIGURATION			
Dash #	Bracket Ass’y “M”	Robot Adapter	Description
0	---	---	NO BRACKET
1	A12552-01	NONE	PAINT MATE ROBOT
2	A12553-01	TABLE D ITEM “D”	HOLLOW WRIST ROBOT
3	A12554-01	NONE	STATIONARY OR POLE MOUNT

TABLE D - ROBOT ADAPTER			
Dash #	Description	“B”	Notes
00	ADAPTER NOT INCLUDED	N/A	
01	FANUC P145/P155	78983-00	STANDARD LENGTH WITH WINDOWS
02	ABB 5400, 5002	79107-00	STANDARD LENGTH WITH WINDOWS
03	FANUC P200/P250	79131-00	STANDARD LENGTH WITH WINDOWS
04	KAWASAKI KE610L	A10847-00	STANDARD LENGTH WITH WINDOWS
05	MOTOMAN PX2850	A10848-00	STANDARD LENGTH WITH WINDOWS
06	MOTOMAN PX2900	A10849-00	STANDARD LENGTH WITH WINDOWS
07	B&M LZ2000	A10851-00	STANDARD LENGTH WITH WINDOWS
08	ABB 5400 ENHANCED WRIST	A12036-00	STANDARD LENGTH WITH WINDOWS
09	MOTOMAN EPX2050	A13697-00	STANDARD LENGTH WITH WINDOWS
10	FANUC P200-P250	A13733-00	EXTENDED LENGTH WITH 1 WINDOW
11	KAWASAKI KE610L	A13734-00	EXTENDED LENGTH WITH 1 WINDOW
12	ABB 5400 ENHANCED WRIST	A13735-00	EXTENDED LENGTH WITH 1 WINDOW
13	MOTOMAN EXP2050	A13736-00	EXTENDED LENGTH WITH 1 WINDOW
14	MOTOMAN EPX2900	A13765-00	STANDARD LENGTH WITH WINDOWS

TABLE E - FLUID FITTING TYPE		
Dash #	“J”	Description
0	---	---
1	LSFI0022-05	FITTING 8M OR 5/16 O.D. TUBE
2	A12543-00	FITTING 3/8 O.D. TUBE (HIGH CONDUCTIVE MATERIAL)

TABLE F - HIGH VOLTAGE CABLE						
Dash #	“P”	Description	“R”	“S”	“V”	“X”
0	---	---	---	---	---	---
1	A10560-25D	25 FT LONG (7.6 METERS)	-421	-621	-121	-321
2	A10560-50D	50 FT LONG (15.2 METERS)	-431	-631	-131	-331
3	A10560-75D	75 FT LONG (22.8 METERS)	-441	-641	-141	-341

TABLE G - POWER SUPPLY						
App.	“Q”	Pneumatic Module	Remote Manifold	Description	“I”	“U”
0	---	---	---	---	0	0
1	80100-211	---	---	9060 POWER SUPPLY - DOMESTIC – 110/120 VOLT- INTERNAL CASCADE	1	1
2	80100-213	---	---	9060 POWER SUPPLY - CHINA – 220/240 VOLT- INTERNAL CASCADE	1	1
3	80146-“R”	80112-00	76791-12	9060 POWER SUPPLY- DOMESTIC – OIL FILLED EXTERNAL CASCADE- PNEUMATIC MODULE	0	0
4	80146-“S”	80112-00	76791-12	9060 POWER SUPPLY- CHINA- OIL FILLED EXTERNAL CASCADE- PNEUMATIC MODULE	0	0
5	80146-“R”	NONE	---	9060 POWER SUPPLY ONLY DOMESTIC – OIL FILLED EXTERNAL CASCADE	0	0
6	80146-“S”	NONE	---	9060 POWER SUPPLY ONLY – CHINA OIL FILLED EXTERNAL CASCADE	0	0
7	80146-“V”	NONE	---	9060 POWER SUPPLY- US 10” RACK OIL FILLED CASCADE	0	0
8	80146-“X”	NONE	---	9060 POWER SUPPLY- CHINA 10” RACK OIL FILLED CASCADE	0	0

INSTALLATION

This information is intended ONLY to indicate the general installation parameters of this product and, where applicable, its working relationship to other Ransburg system components in typical use.

Each installation is unique and should be directed by an authorized Ransburg representative or conducted using the Ransburg installation drawings provided for your particular installation.

High Voltage Cable and Tubing (Installation)

1. Connect the high voltage cable to the body assembly by first adding a small amount of dielectric grease (NOT petroleum jelly) to the banana plug end. Fully insert cable until it bottoms out in the plug receptacle. Once fully inserted, place the red collet lock behind the collet to secure the cable in place. Gently pull the cable to ensure it is locked securely.
2. Insert the 5/16" (8mm) or optional 3/8" PTFE paint line into the compression fitting and tighten securely. Use two wrenches to prevent fitting from turning. Gently pull on the tubing to ensure it is secure.
3. Install the 5/16" (8mm) fan and atomization air tubing into the collet style fittings. Make sure to push the tubing past the o-ring. Gently pull on the tubing to ensure it is secure.

4. Install the 5/32" (4mm) trigger pilot tubing into the collet style fitting. Make sure to push the tubing past the o-ring. Gently pull on the tubing to ensure it is secure.
5. If equipped with dump valve: Install the 5/16" (8mm) dump line (PTFE) into the compression fitting on the dump block body. Use two wrenches to prevent fitting from turning. Gently pull on the tubing to ensure it is secure. Install the 5/32" (4mm) dump pilot tubing into the collet style fitting. Make sure to push the tubing past the o-ring. Gently pull on the tubing to ensure it is secure.

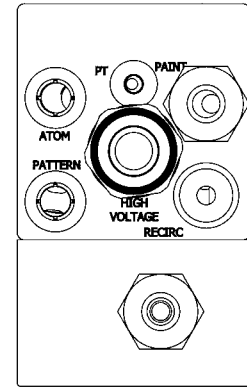
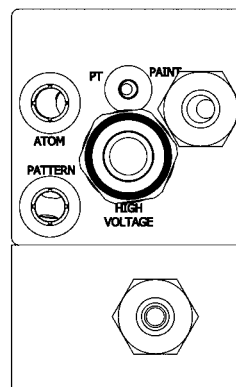

Recirculation version has additional fluid port for return line

High Voltage Cable and Tubing (Removal)

**Ensure high voltage is turned OFF and pressure in ALL air and fluid lines are at ZERO.

1. High voltage cable: Remove red retaining clip. Push down on the collet and then pull cable straight out.
2. Air tubing (all): Push down on collet and pull straight out.
3. Fluid tubing (all): Use two wrenches to prevent the fitting from turning. Loosen nut and ferrule and remove by hand.



Changing Gun Head Angle

1. To change the angle of the gun head, the shoulder screws need to be removed.
2. Align the threaded holes to the gun head angle position desired.
3. Install shoulder screws and tighten to a final torque of 15 lbs-in (1.69 Nm).

Paint Mate Robot

1. Typical tubing bundle management consists of wrapping entire bundle with spiral wrap.
2. Start at approximately 18 inches or 457mm behind the applicator.
3. Wrap every 2-3 ft. (.6 -.9m).
4. Route tubing through the center arm open area.
5. Secure a strain relief (surgical tubing) from the main support arm and attach to the tubing.
6. Allow at least 2-3 ft. (.6 -.9m) of slack in tubing at the applicator.
7. Tubing on wrist rotation should be held to a maximum rotation of 430°.
8. Cycle program slowly to check for any pinch or catch points.

Non-Hollow Wrist / Hollow Wrist Conversion

Conversion from a non-hollow wrist robot configuration to a hollow wrist robot can be easily done by removing the screws indicated in the above drawing and simply lifting out the center piece.



Wrist Configuration Conversion

Ransburg REA-III / Evolver SE Conversion Bracket

With the optional conversion bracket (see below), the Evolver SE can be a direct replacement for the Ransburg REA-III gun.



Evolver SE to 80120 Power Supply Connections

The drawing below shows the connections between the Evolver SE and the 80120 power supply.

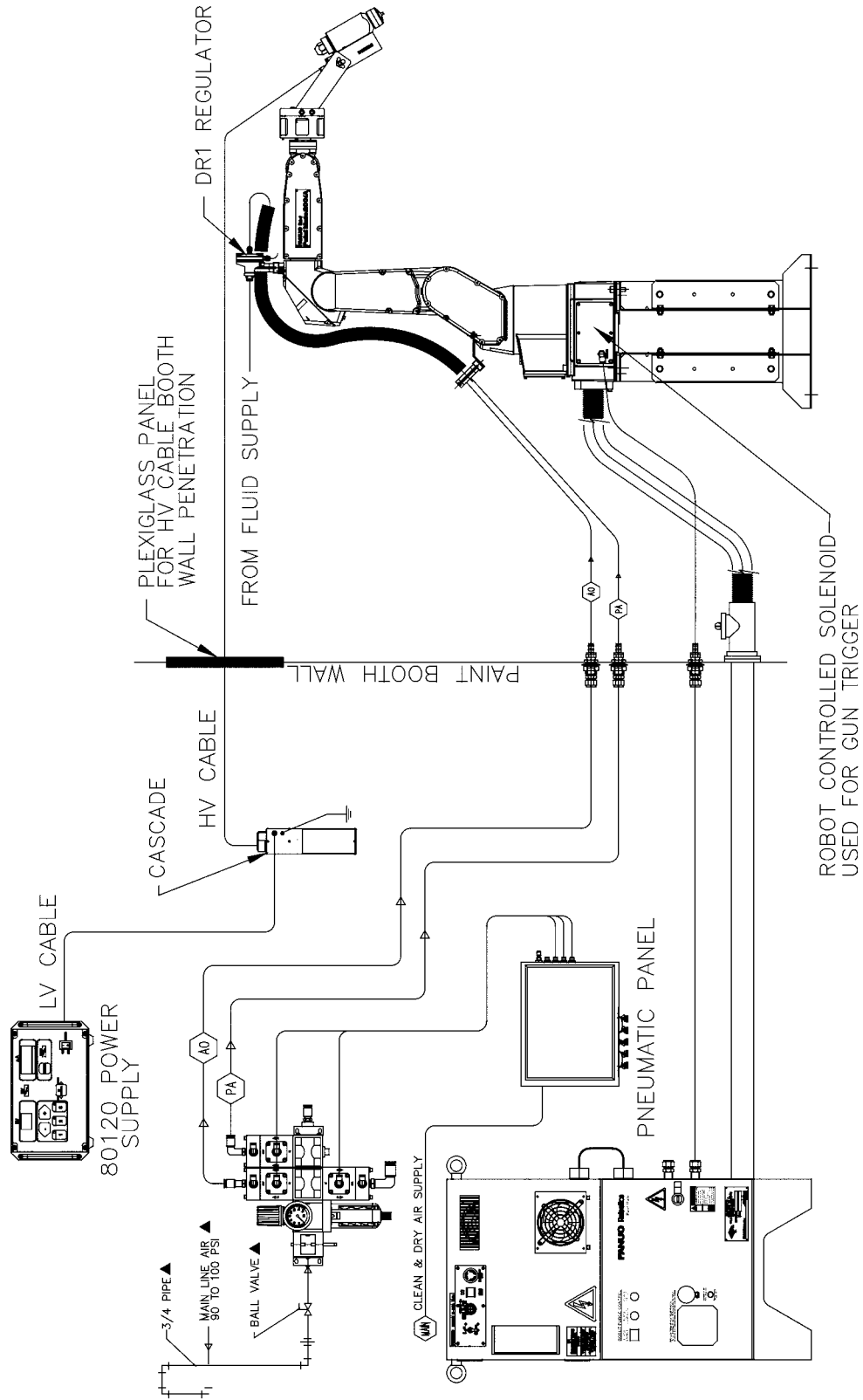

Evolver SE to 80100 Power Supply Connections

The drawing below shows the connections between the Evolver SE and the 80100 power supply.

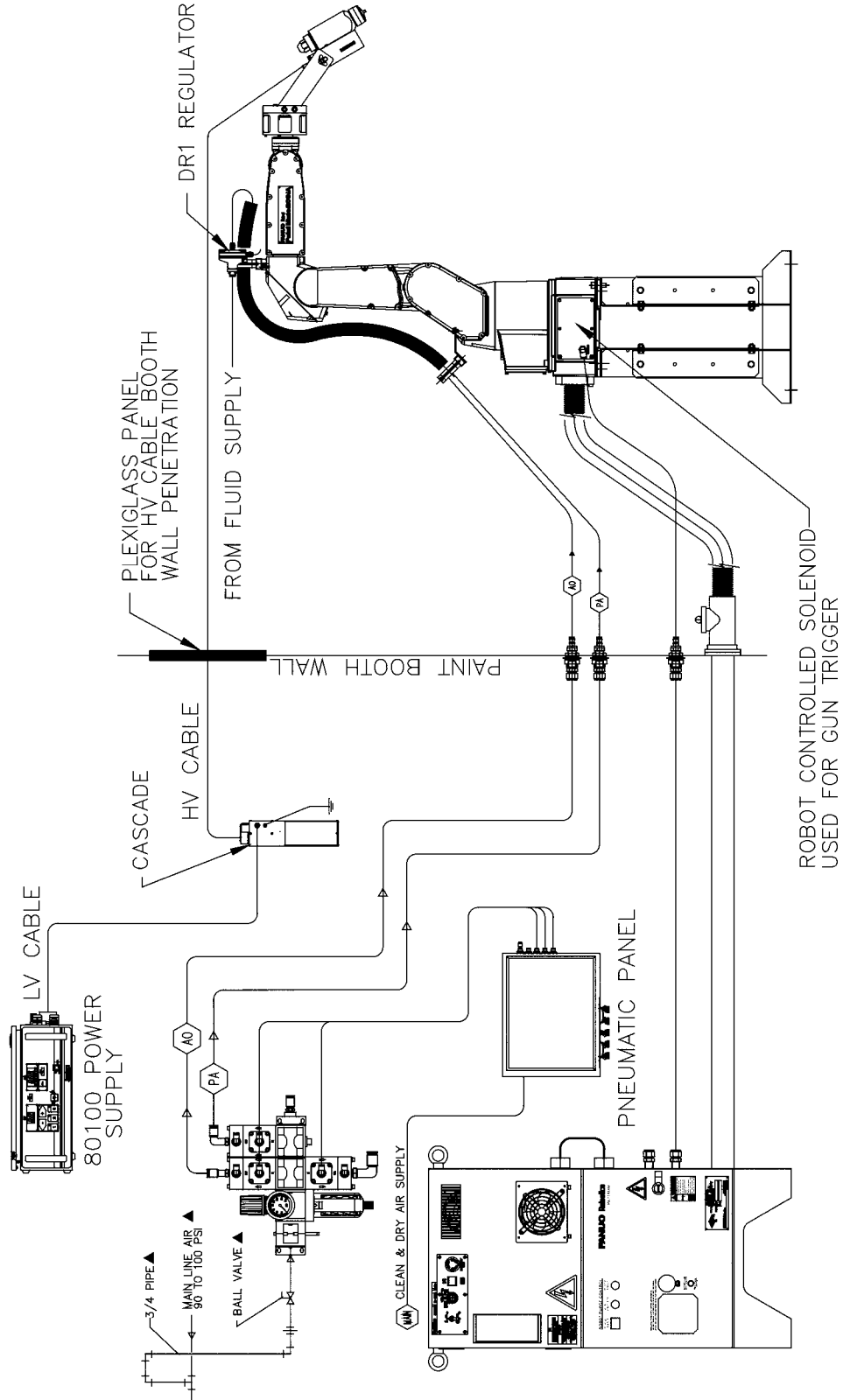

OPERATION

⚠ WARNING

- Operators must be fully trained in safe operation of electrostatic equipment. Operators must read all instructions and safety precautions prior to using this equipment (see NFPA-33, EN 50176).
- Electrical discharge of a high electrical capacitance fluid/paint system can cause fire or explosion with some materials. If arcing occurs when a specific coating material is used, turn the system OFF and verify that the fluid is non-flammable. In these conditions, the system is capable of releasing sufficient electrical and thermal energy to cause ignition of specific hazardous materials in the air.



As with any spray finishing system, operation of the Evolver SE involves properly setting the operating parameters to obtain the best finish quality for the coating material being sprayed while maintaining correct operation and reliability of the equipment used. Adjustments to operating parameters, which cover spraying, cleaning, and ON/OFF control, include the following:

- Coating Materials
- Fluid Flow Rate Control
- Fluid Valve / Trigger Control
- Atomization Air (paint atomization control)
- Fan Air (pattern control)
- Electrostatic Voltage
- Target Distance

GENERAL GUIDELINES

Paint Viscosity: The applicator is capable of atomizing paint of most any desired viscosity, however it is recommended to keep the material viscosity as low as possible. This allows spraying at lower fan and atomization air pressures which result in less overspray and higher transfer efficiency.

⚠ WARNING

- Most paints and solvents are toxic to a certain degree and flammable or combustible. Use them only in a well ventilated atmosphere. Use protective equipment as required in the Material Safety Data Sheet (MSDS) supplied with the substance.

Fluid Flow Rate

Fluid flow is adjusted through the robot PLC by varying the pilot pressure to an exterior fluid regulator. Fluid pressures from the circulating system may exceed the maximum fluid pressure rating of the Evolver SE applicator. Because of these high fluid pressures, a manual step-down fluid regulator must be used.

Target Distance

The distance between the applicator tip and the article being painted should be 10-14 inches (254-356mm) when using high voltage. Excessive distance will reduce transfer efficiency and cause wrap back (paint particles being deposited on the applicator body or the robot arm). At close distances the voltage at the tip of the applicator will be reduced, which decreases the charging effect of the applicator.

 **WARNING**

► If target distance is less than 8 inches (203mm), an arc could occur.

Electrostatic Voltage

Under no load conditions, the maximum voltage limit for the Evolver SE applicator is 85 kV. Some painting operations may require different voltage settings to obtain optimum transfer efficiencies. If Faraday cage areas (narrow or recessed areas) are predominant on the item being painted, a lower voltage setting would aid in coating these areas. When not spraying, it is recommended to set back voltage 30-40 kV or OFF between target parts. Sometimes, depending on the target carrier spacing, higher setback voltages may be required.

EVOLVER SE GUN CONTROLS

(Fluid Valve / Trigger)

Trigger and Dump

The fluid valves in the Evolver SE are actuated by an air signal. The air pressure must exceed 70 psi (4.8 bar) to assure proper actuation of the valve. Applying air to the valve actuator turns on the fluid flow for the valve.

The paint trigger valve controls the paint flow to the applicator. When actuated, paint flows through the valve to the fluid tube and into the spray head.

The dump valve controls the paint flow through the dump line. When actuated, paint flow is directed to the dump return line. This provides a method of rapidly removing paint from the incoming line for cleaning and/or color change. Normally the dump valve is not actuated at the same time as the paint valve since the paint valve is intended to cause the fluid to flow to the applicator head at the set input pressure.

EVOLVER SE GUN CONTROLS (Air)

Atomization (A) / Fan Air (F)

The atomization and fan air are turned on by the trigger line and are controlled by an internal air valve located in the applicator head. During normal operation with the applicator triggered off, there is a slight bleed of air through the atomization port. This helps keep the passage clean.

Atomizing Air

Adjustments are made through the robot PLC or a manually adjustable air regulator. The lowest air pressure required to break up the paint should be used. Lower atomizing air pressures result in less overspray and increased transfer efficiency.

Fan Air

Adjusting the fan air increases or decreases the size of the spray pattern. Increasing pressure increases pattern size. Pattern adjustment should be made to suit the size and shape of the object being painted. This adjustment is made through the robot PLC or a manually adjustable air regulator.

LVMP

LVMP (TransTech) is available standard on the Evolver 500 Series. LVMP operates on Lower Volume Medium Pressures. LVMP has higher transfer efficiency compared to standard air spray without electrostatics. With electrostatics, comparable efficiency is higher.

EVOLVER SE GUN CONTROLS

(Mechanically Timed Trigger)

The mechanically timed trigger of the Evolver SE ensures that the atomization and fan air are ON before paint flows out of the applicator (see diagram below). This helps prevent the gun from spitting paint from lack of atomization or fan air.

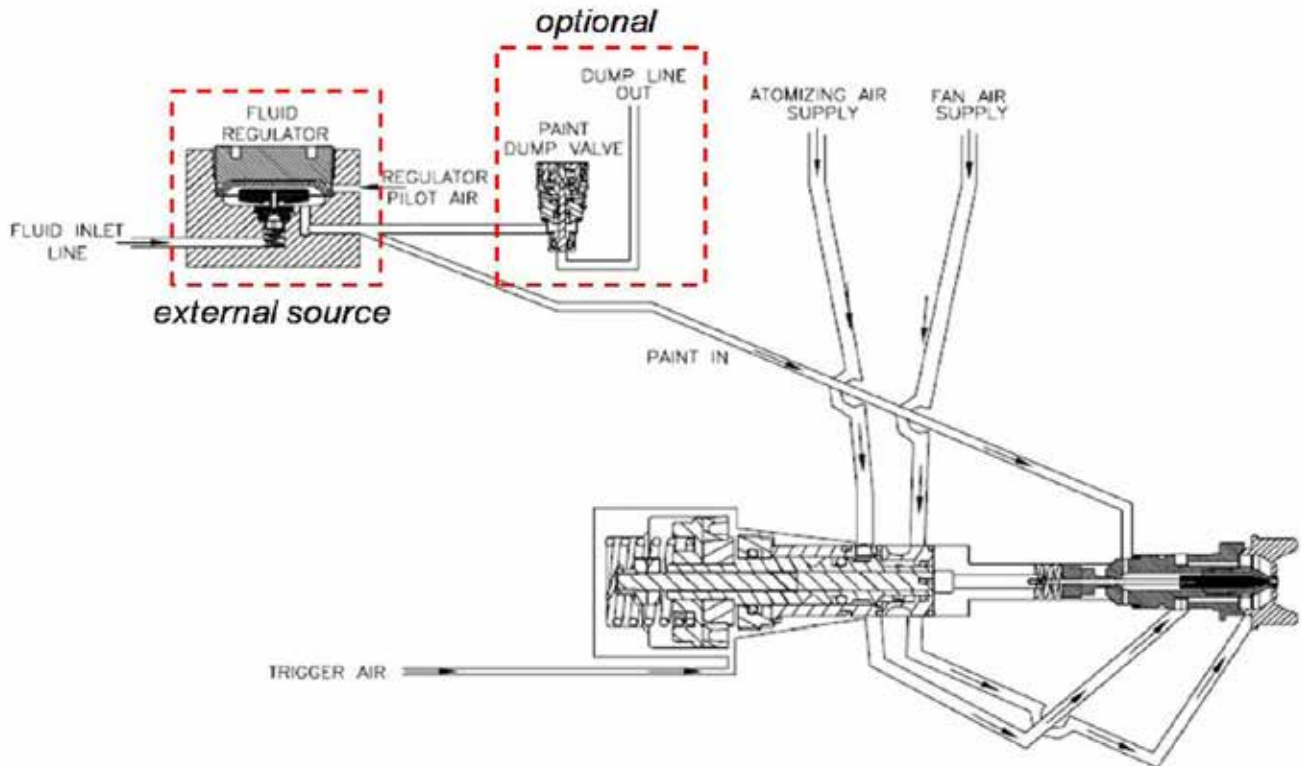

MAINTENANCE

Good maintenance is essential to safe and productive operation. Schedules should be established by the user, based on the following general information and observations of the initial production requirements.

The Ransburg maintenance and safety information should be made available to each operator.

Normal fire protection measures are necessary, including proper storage of paints and solvents and the proper disposal of waste. Ready access to appropriate fire extinguishing equipment is required. For details, consult the appropriate NFPA safety information, your local fire codes, local painting equipment standards, OSHA requirements, as well as your insurance carrier's information.

!
WARNING

- Unexpected robot movement can be hazardous. Do not adjust or repair the spray applicator when the robot is operating or waiting to start. The robot must be locked out and tagged out per OSHA.
- Do not adjust or repair the spray applicator when the power supply is ON. Turn OFF the power supply and follow OSHA lockout / tagout procedures.
- Those used for equipment flushing should have flash points equal to or higher than those of the coating material.
- Those solvents used for cleaning must have a flash point at minimum of 5°C (9°F) greater than the ambient temperature. It is the end users responsibility to insure this condition is met.
- Never remove spray applicator head from assembly while it is under pressure.



ROUTINE MAINTENANCE SCHEDULE

Follow these maintenance steps to extend the life of the applicator and ensure efficient operation:

Several Times Daily

Step 1

Inspect the fluid nozzle and electrode wire for paint accumulation. Clean as frequently as necessary. (See "Procedures" in the "Maintenance" section.)

(Continued On Next Page)

ROUTINE MAINTENANCE SCHEDULE (Cont.)

Daily (or at Shift Start)

Step 1

Inspect work holders for accumulated coating materials (remove such accumulations if present). Using a Meg Ohm meter, measure the resistance of the work holder to ground (should be less than 1 Mega Ohm), at 250V or 500V.



Step 2

Check that the nozzle assembly is clean and undamaged.

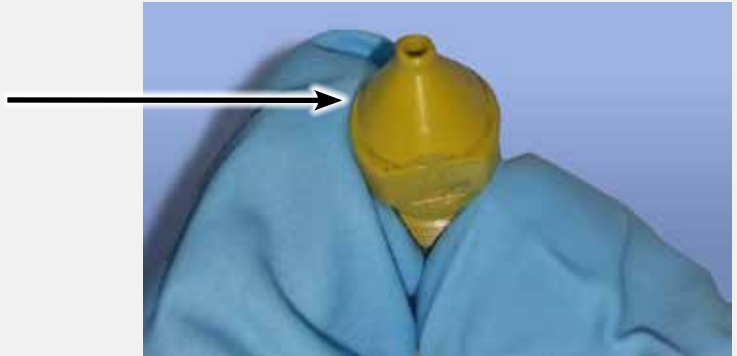

Shut Down (or at Shift End)

Step 1

Flush the lines and allow the solvent to remain in the lines. (See “Procedures” in the “Maintenance” section.)

Step 2

Wipe the applicator and robot wrist with a cloth and a suitable, clean non-polar solvent.

Weekly

Step 1

Check the entire system for damage, leaks and paint accumulation.

Step 2

Clean the atomizer assembly.

APPLICATOR CLEANING

Step 1

Flush the paint supply line and the applicator paint passages using a solvent which is compatible with the material being sprayed. Continue to flush until all traces of paint are gone.

Step 2

Turn off the solvent supply, actuate paint push out air at the color changer and trigger the applicator. Allow all of the fluid to drain from the spray applicator fluid passages.

Step 3

Clean the exterior surfaces of the spray applicator with a solvent soaked rag.

Step 4

Remove end cap. Removing the end cap releases tension on all internal spray head components. Remove needle spring and valve spring, which are loose after removing the piston cap.

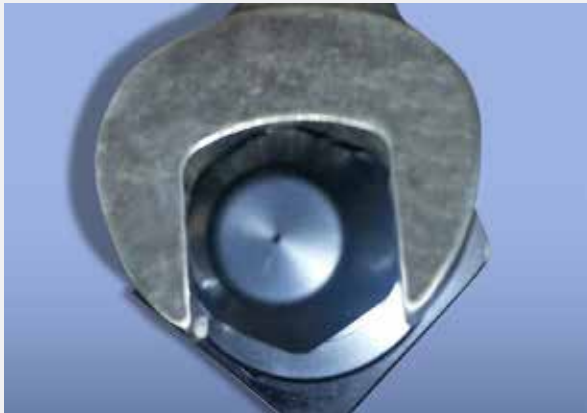

Remove end cap.

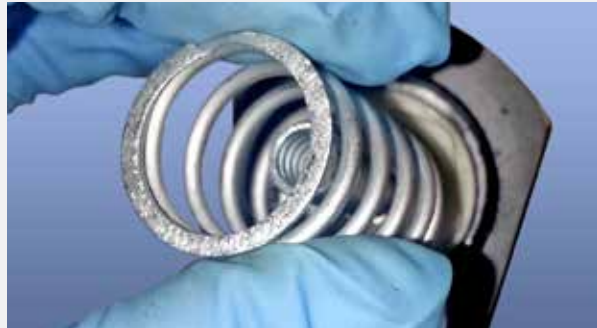

Remove needle spring.



Remove needle spring.



Remove end cap.



Remove valve spring.

(Continued On Next Page)

APPLICATOR CLEANING (Cont.)

Step 5

Remove the air cap retainer and air cap. Soak in a solvent if necessary. If paint remains in the air cap holes, clean with a toothpick or similar soft wood object. Air caps are best cleaned in an ultrasonic cleaner.

! CAUTION

► Never attempt to clean the air cap holes with a wire or other metal object. Doing so may damage the air cap, resulting in distortion of the spray pattern.

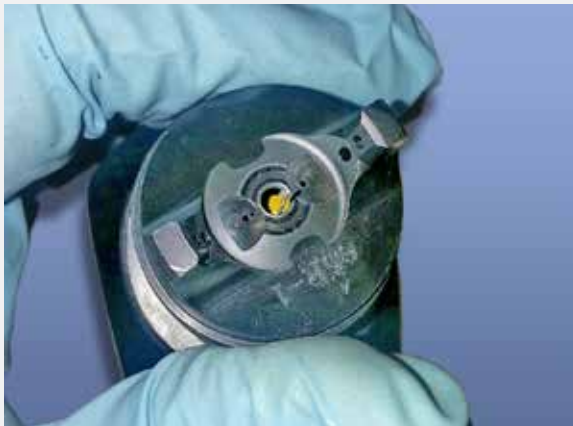

Step 6

Remove the air cap locator and fluid tip. Clean using a solvent.



(Continued On Next Page)

APPLICATOR CLEANING (Cont.)

Step 7

Tightly grip the needle and unscrew counter-clockwise to remove the electrode. A short piece of H-2339 tubing (1/4" OD x 0.175" ID) pressed over the electrode will assist in unscrewing the assembly. If required, use needle nose pliers with masking or duct tape. Carefully clean with a solvent. Replace any parts that show signs of wear or damage.



Step 8

Remove fluid nozzle by unscrewing counter-clockwise. Inspect o-ring and all passages for build-up or damage. Clean or replace as necessary. Lubricate and reinsert o-ring into applicator barrel and reinstall fluid nozzle. Torque fluid nozzle to 25 lbs-in (2.82 Nm).

NOTE

- There should be a small gap between the fluid nozzle and the applicator barrel after tightening.

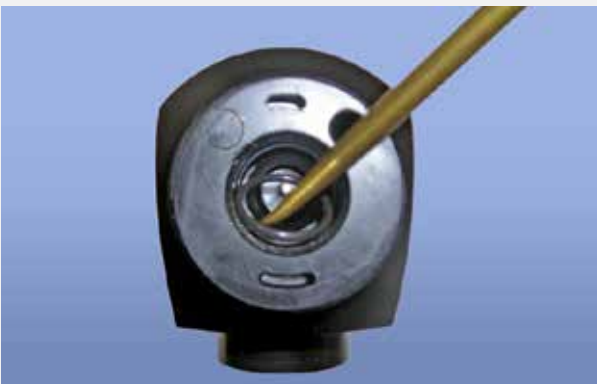

(Continued On Next Page)

APPLICATOR CLEANING (Cont.)

Step 9

After cleaning, insert the front needle back into the spray head assembly. Apply low strength (purple) thread locker, to the threads of the tip assembly before reassembly.



Step 10

Install the electrode.

NOTE

➤ The electrode should always be installed and tightened before installing the fluid tip and valve springs.



Step 11

Screw fluid tip back into place. Hand tighten first, then with a small wrench, tighten an additional 30°.

CAUTION

➤ After tightening the fluid tip, always check to see if the proper gap of 1/16" (1.59mm) between the needle nuts and air valve stem occur, before installing the needle and valve springs back into the head.



(Continued On Next Page)

APPLICATOR CLEANING (Cont.)

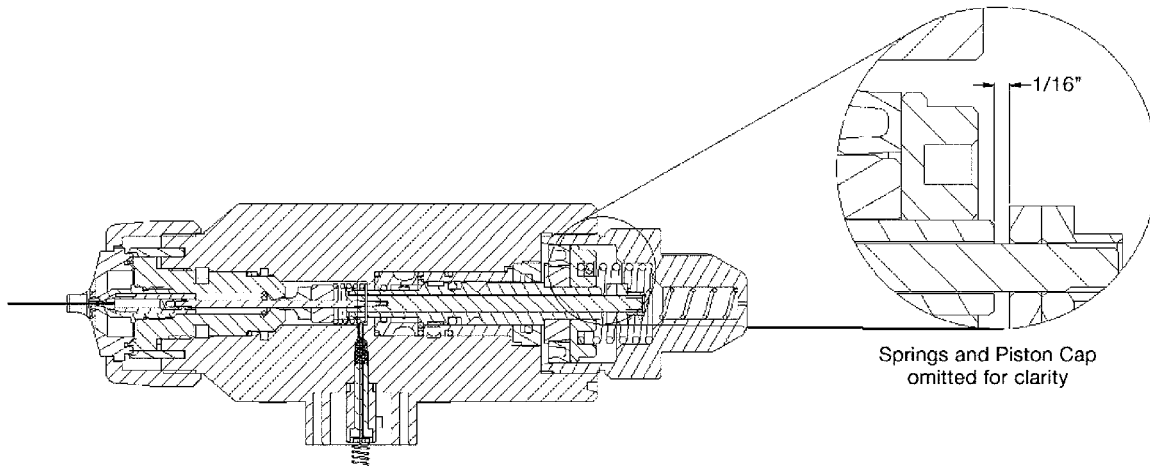

Step 12

Replace air cap locator, air cap, and air cap retainer .

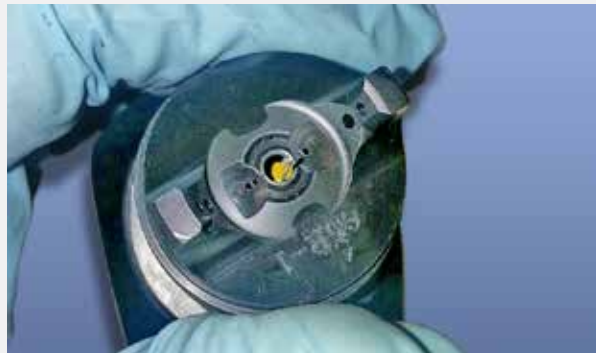

APPLICATOR CLEANING (Cont.)**Step 13**

Apply a thin film of petroleum jelly to valve and needle springs. Install the springs back into the end cap and the spray head assembly.

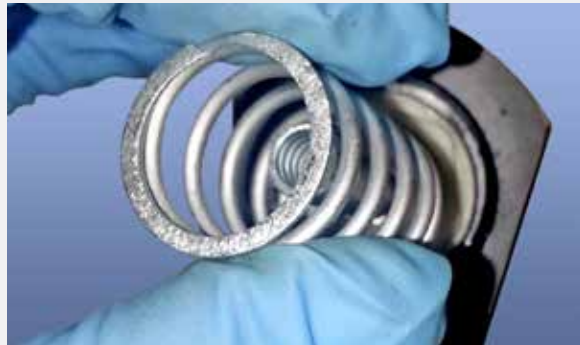
**Step 14**

Screw end cap back on. Reassembly complete!



SERVICE

! WARNING

➤ Unexpected robot movement can be hazardous. Do not adjust or repair the spray applicator when the robot is operating or waiting to start. The robot must be locked out and tagged out per OSHA prior to removing the applicator from the robot manifold assembly.

Before performing any work on the spray applicator, always flush the fluid passages and blow dry with push-out air, and wipe the spray applicator clean. Refer to “Gun Cleaning / Service” in the “Maintenance” section, for instructions on how to properly clean the spray applicator. Depressurize all fluid and air pressures before removing the applicator from its manifold. Always work in a clear, clean space to minimize part loss and damage.

! WARNING

➤ Eye protection should be worn while servicing gun.

! CAUTION

➤ As the spray head is removed from the valve manifold assembly, a certain amount of residual fluid may be present. Care must be taken not to allow the fluid to drain into the high voltage terminal rings or air passages.

NOTE

➤ Disassemble spray head only enough to remove and replace defective parts. For instance, if only replacing the front electrode it is not necessary to remove the fluid nozzle.

NOTE

➤ To prevent damage, always lubricate the o-rings located on the underside of the spray head.

PROPER TOOLS



Wrenches / Special Tools

3/8" drive, in./lbs. torque wrench standard hex key set combination wrenches(1/4", 15/16", 11/32", 9/16", 1-1/8", 2-3/8"), seal carrier tool, socket for seal carrier tool.



Screwdrivers

Flat head screwdrivers and torque screwdrivers.



Miscellaneous

Sealants, lubricants and insulators.

SPRAY HEAD ASSEMBLY (Removal)

Step 1

Remove four screws as shown.



SPRAY HEAD DISASSEMBLY

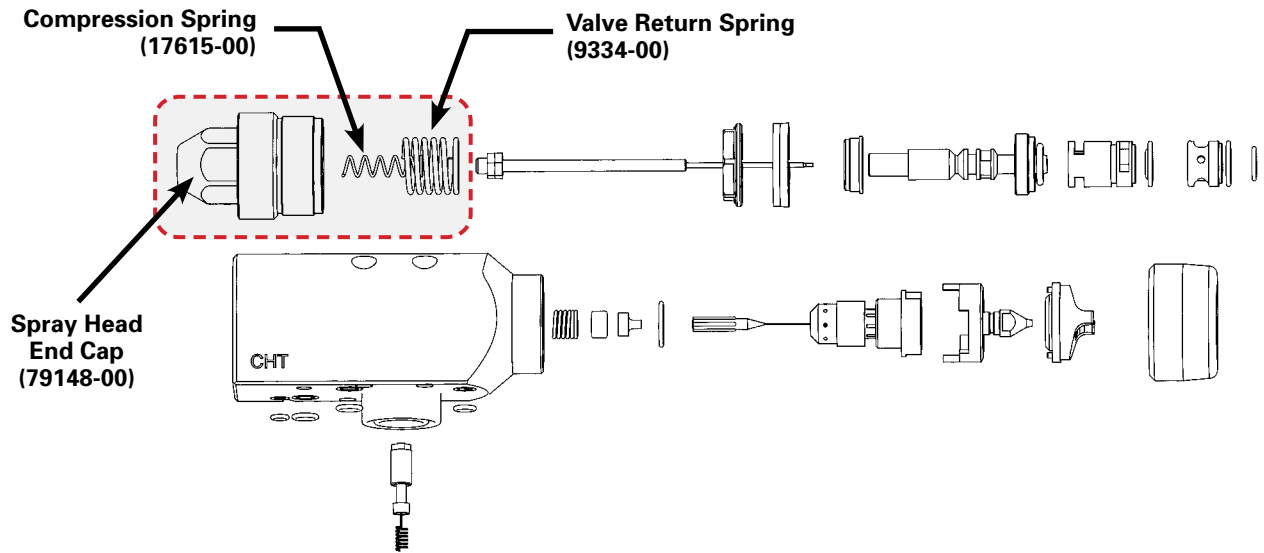

Step 1

Remove spring tension on the electrode / fluid tip by removing the piston end cap.

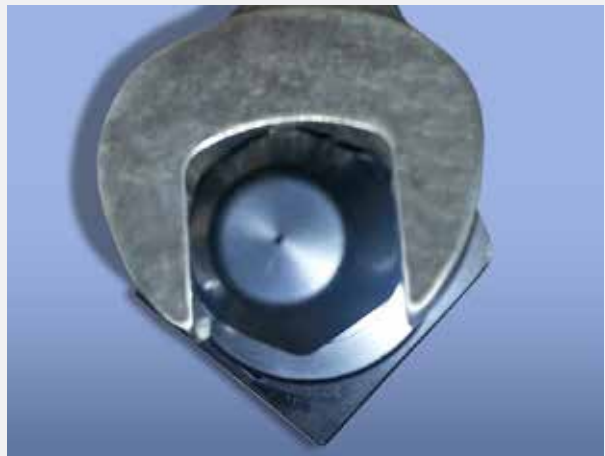

Step 2

Remove the piston and needle return springs.

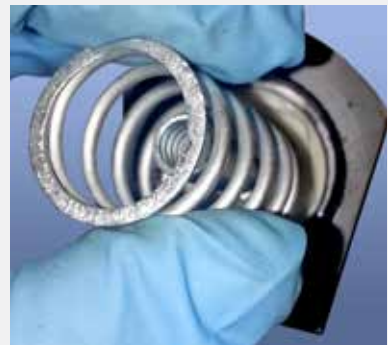

SPRAY HEAD DISASSEMBLY (Cont.)

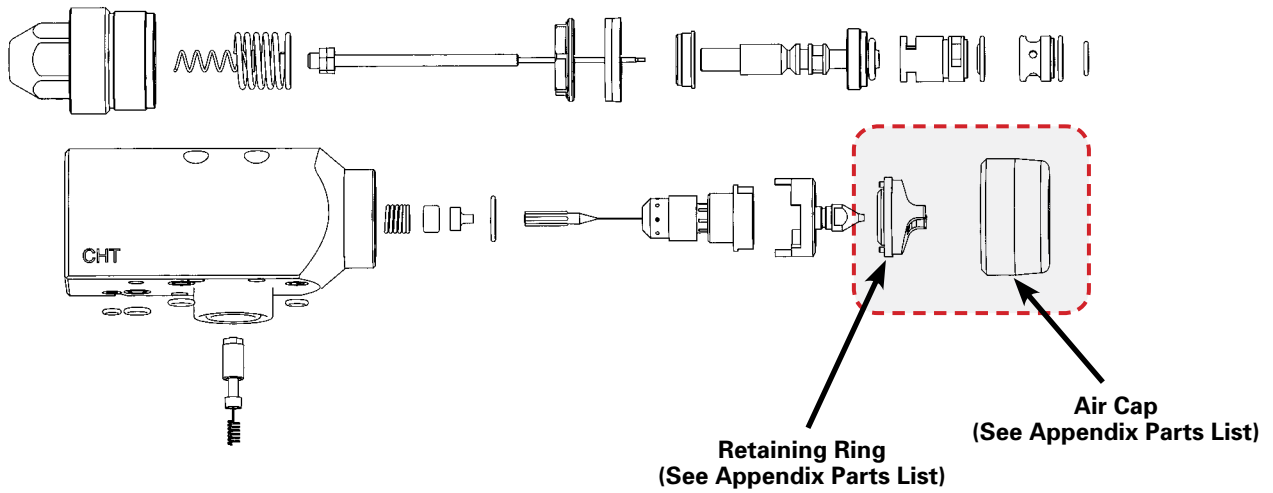

Step 3

Loosen and remove the air cap retaining ring.

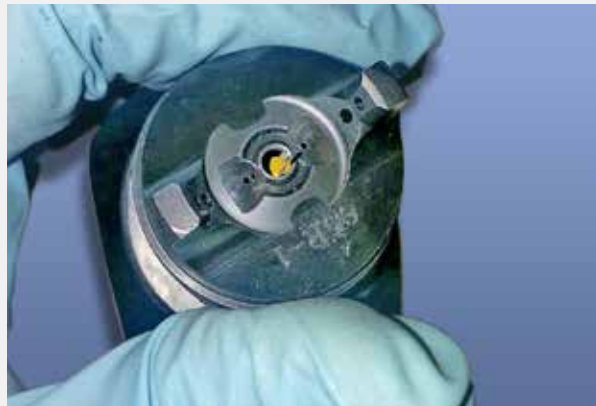

Step 4

Remove and inspect the air cap:

- Wear.
- Material build-up.
- Cracks or damage.

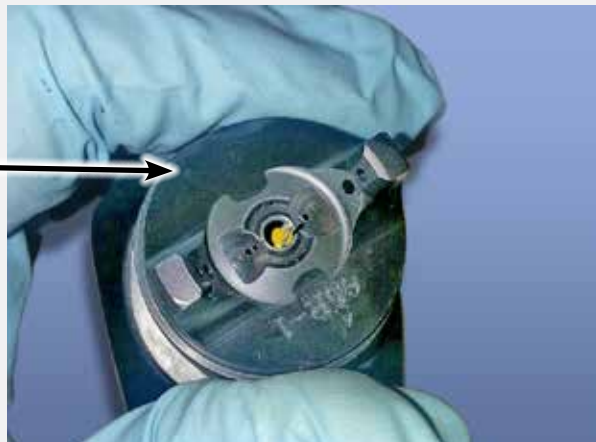

SPRAY HEAD DISASSEMBLY (Cont.)

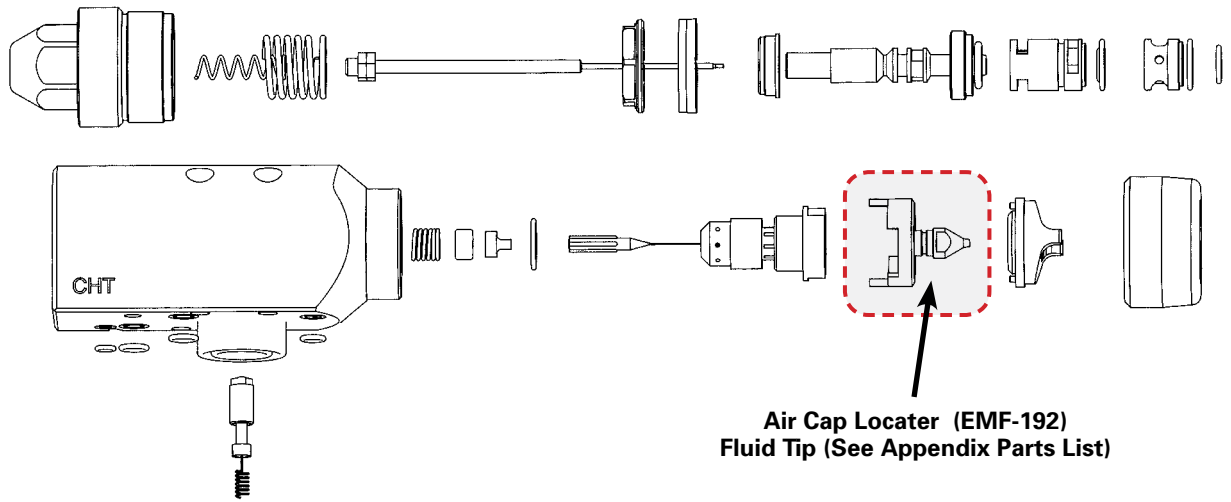

Step 5

Remove the air cap locator.



Step 6

Remove and inspect the fluid tip.



SPRAY HEAD DISASSEMBLY (Cont.)

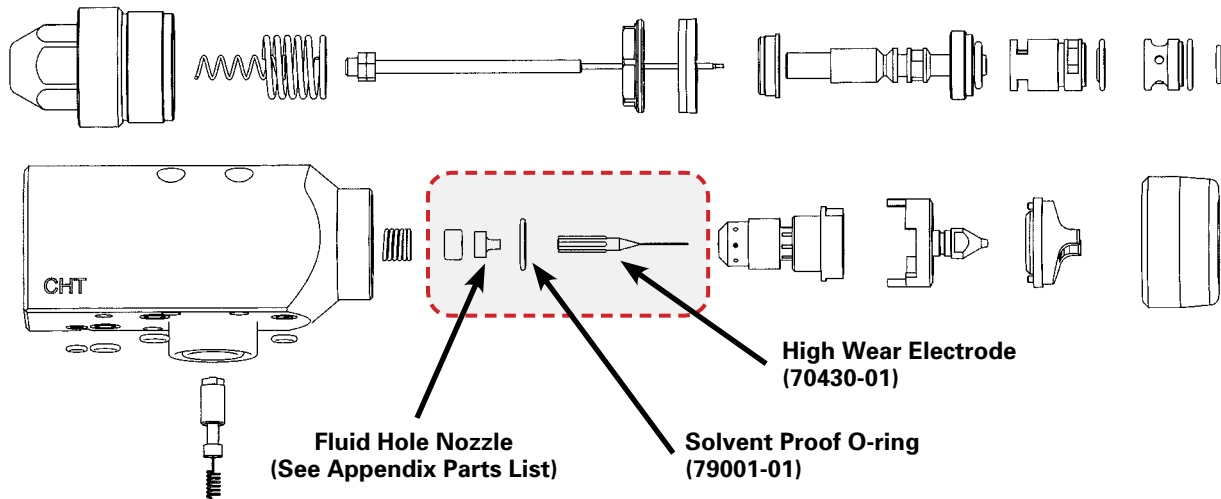

Step 7

Remove the electrode:

- Turn counter-clockwise.
- Use H-2339 tubing (1/4" OD x 0.175 ID) if necessary.
- Inspect tapered surface for damage.
- Wire should be straight and roughly 1/2" long.



Step 8

Remove and inspect the fluid nozzle.



SPRAY HEAD DISASSEMBLY (Cont.)

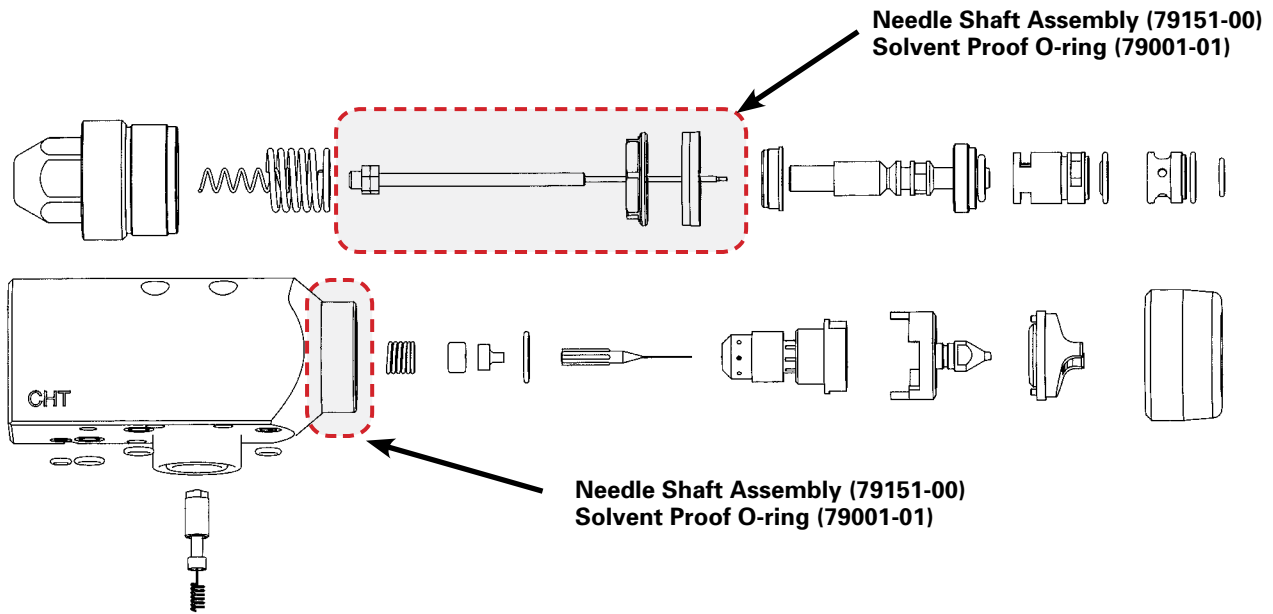

Step 9

Remove the o-ring from the spray head if it does not come out with the nozzle.

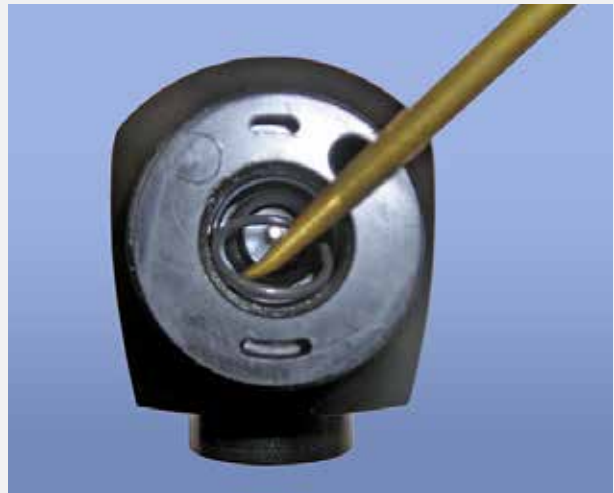

Step 10

Remove the rear needle assembly.



SPRAY HEAD DISASSEMBLY (Cont.)

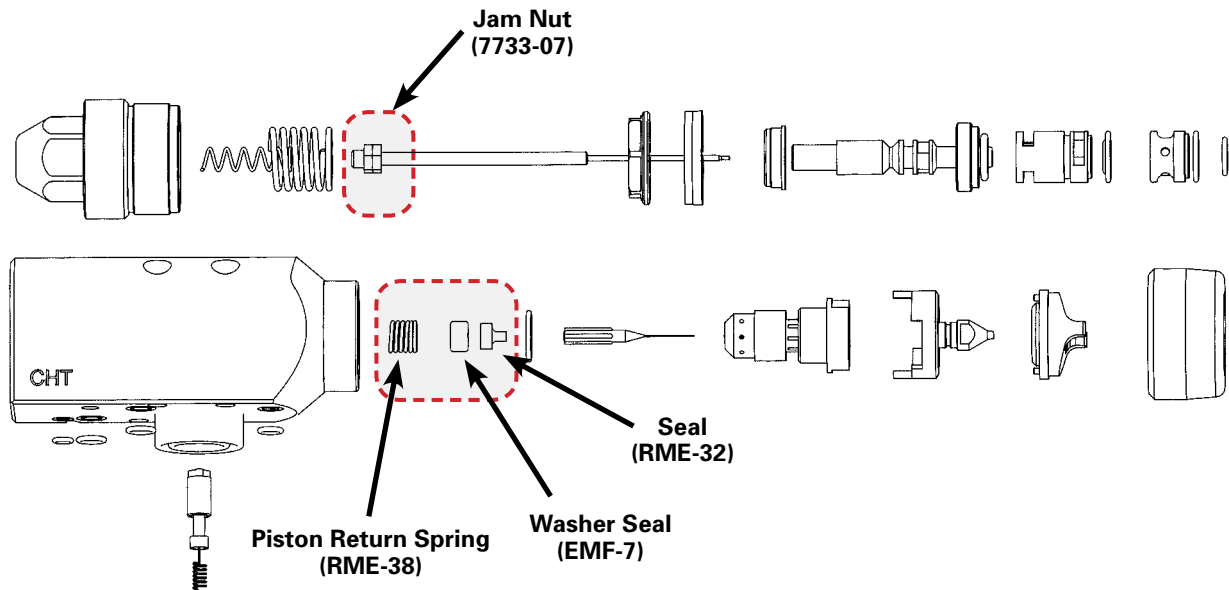

Step 11

The fluid seal, seal washer, and seal spring can now be removed from the front of the gun.



Step 12

Use two 3/8" wrenches to loosen the air valve adjustment nut and jam nut.

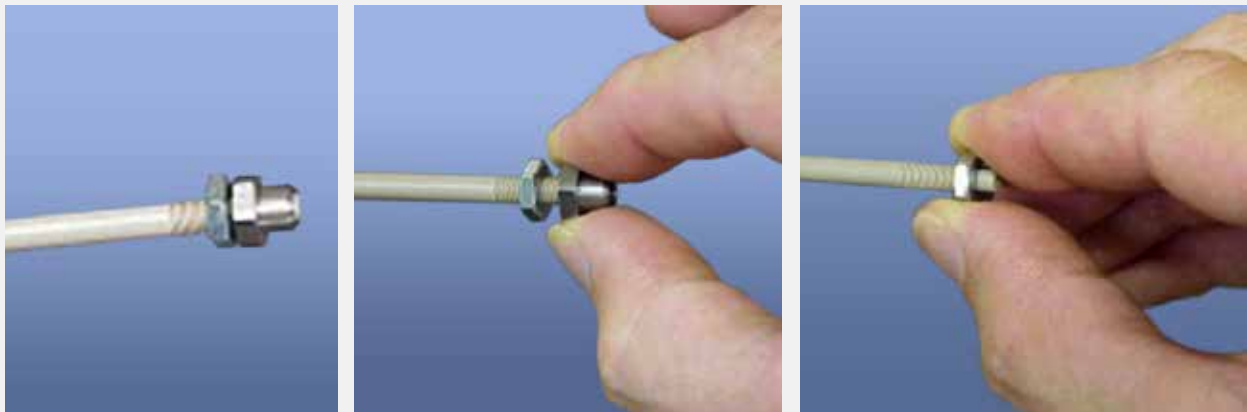

SPRAY HEAD DISASSEMBLY (Cont.)

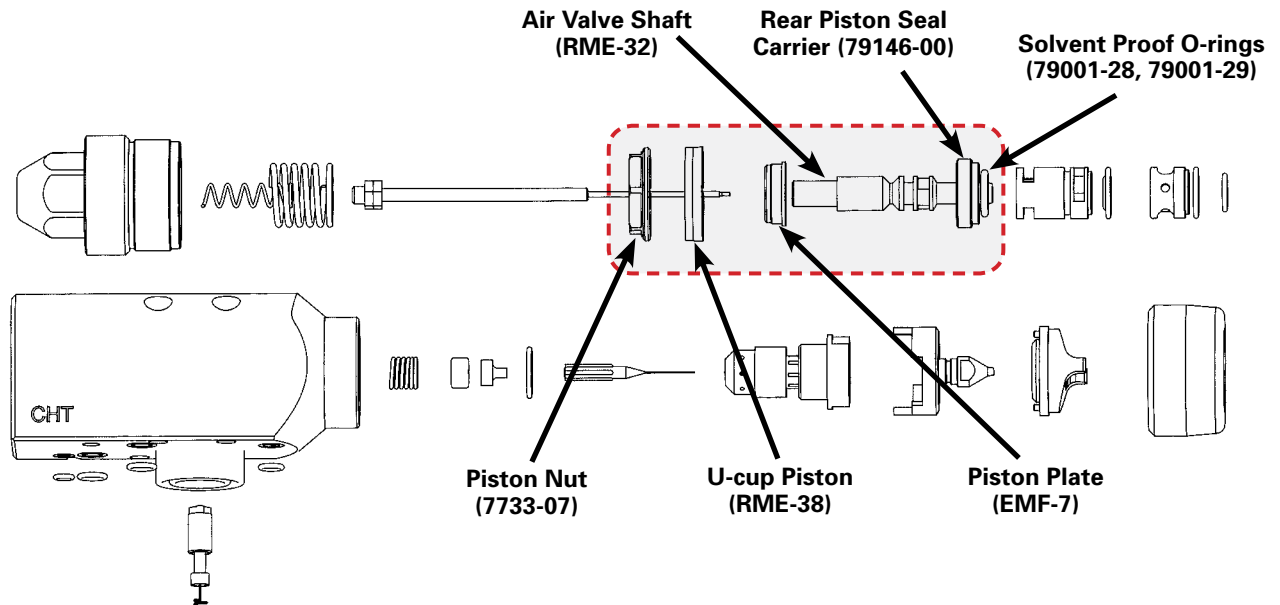

Step 13

Slide the piston assembly out of the body (use pliers if necessary).

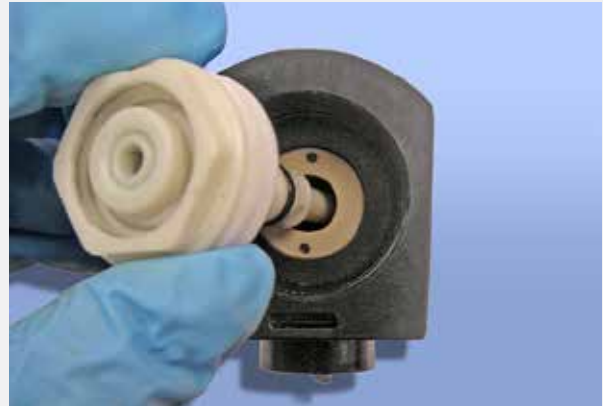
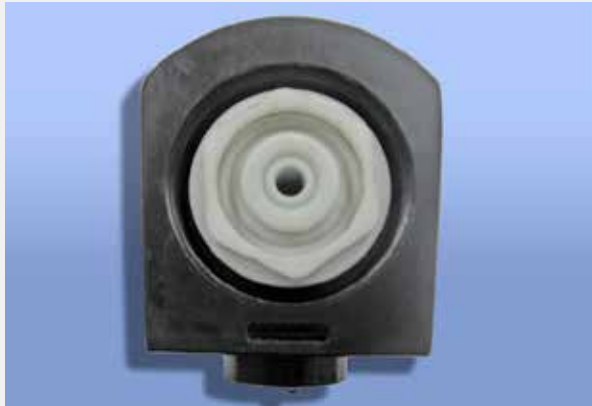

Step 14

Remove the piston nut.



SPRAY HEAD DISASSEMBLY (Cont.)

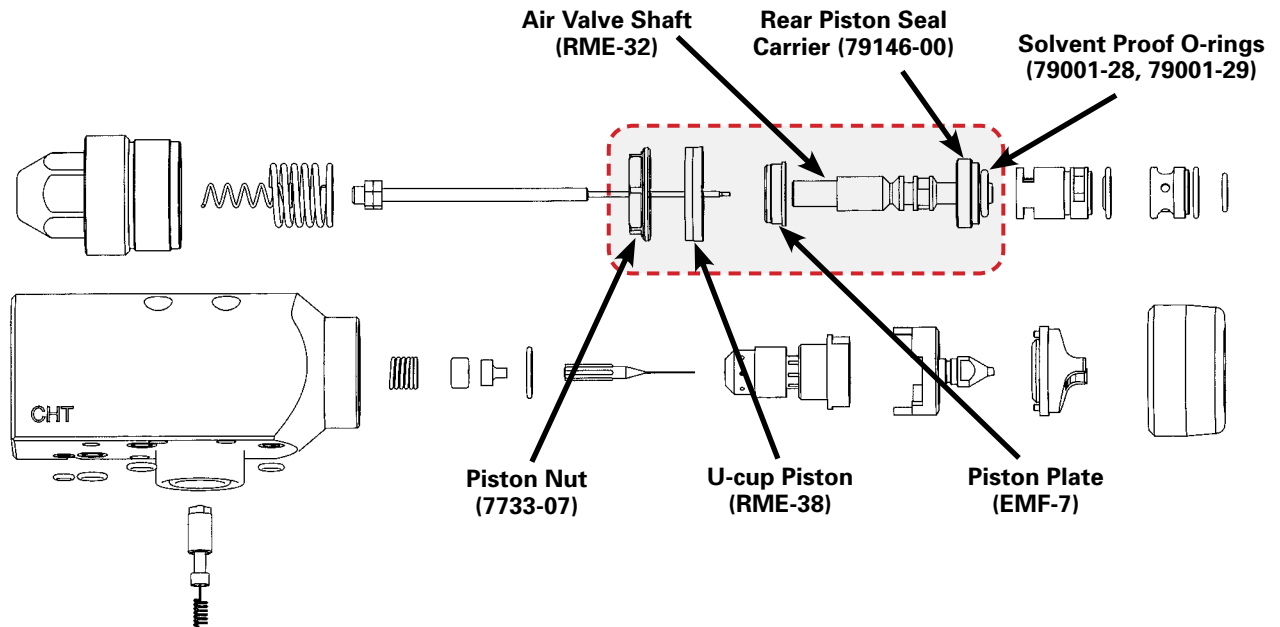

Step 15

Remove the piston u-cup from the piston plate.



Step 16

Remove the o-ring from the air shaft.



SPRAY HEAD DISASSEMBLY (Cont.)

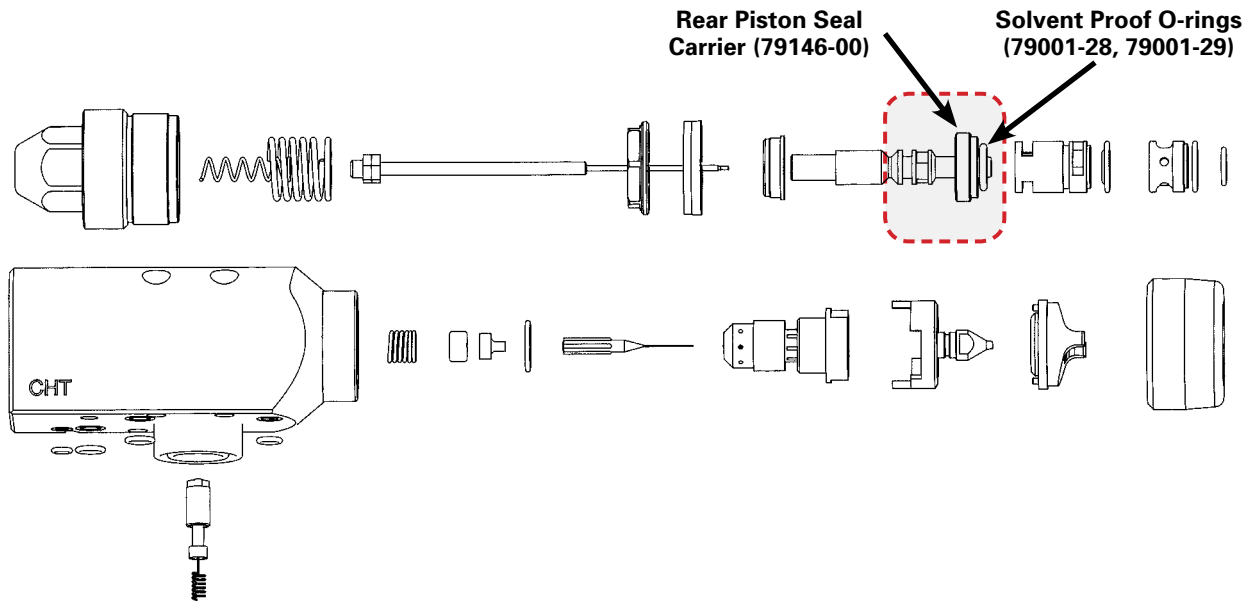

Step 17

Using the seal carrier tool, remove the seal retainer from the spray head.

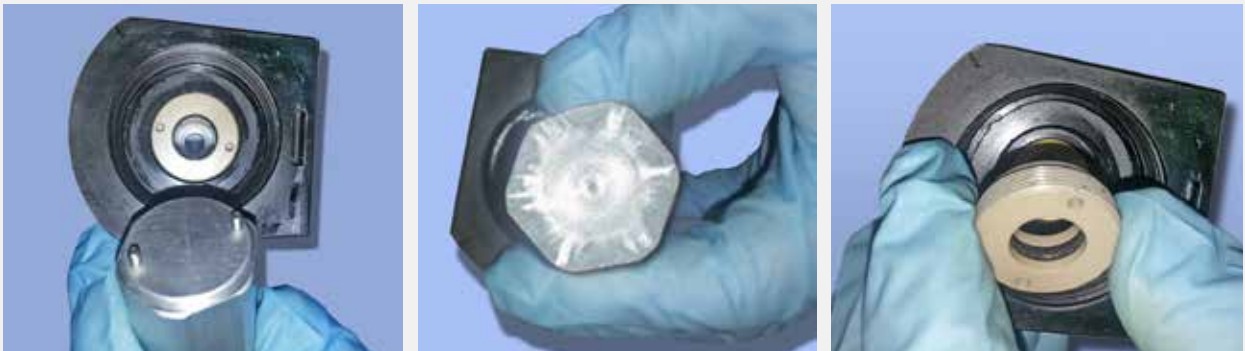

Step 18

Remove the o-ring from the seal retainer.

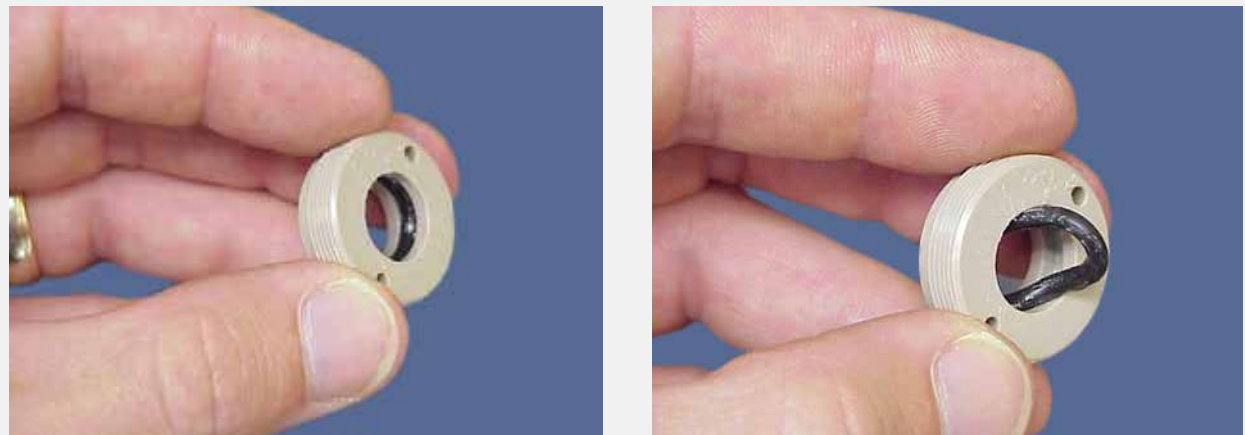

SPRAY HEAD DISASSEMBLY (Cont.)

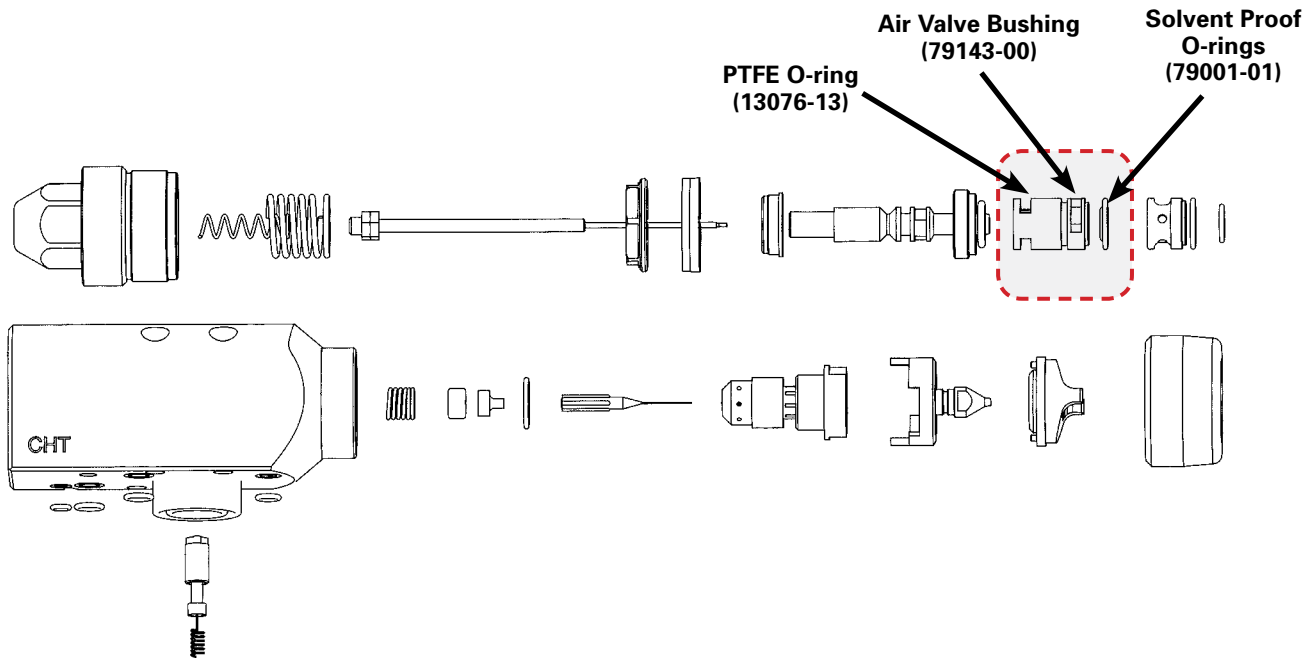

Step 19

Slide the bushing out of the spray head. It may require hooking and pulling the bushing out using an Allen wrench or similar object.



Step 20

Remove the two o-rings from the bushing.



SPRAY HEAD DISASSEMBLY (Cont.)

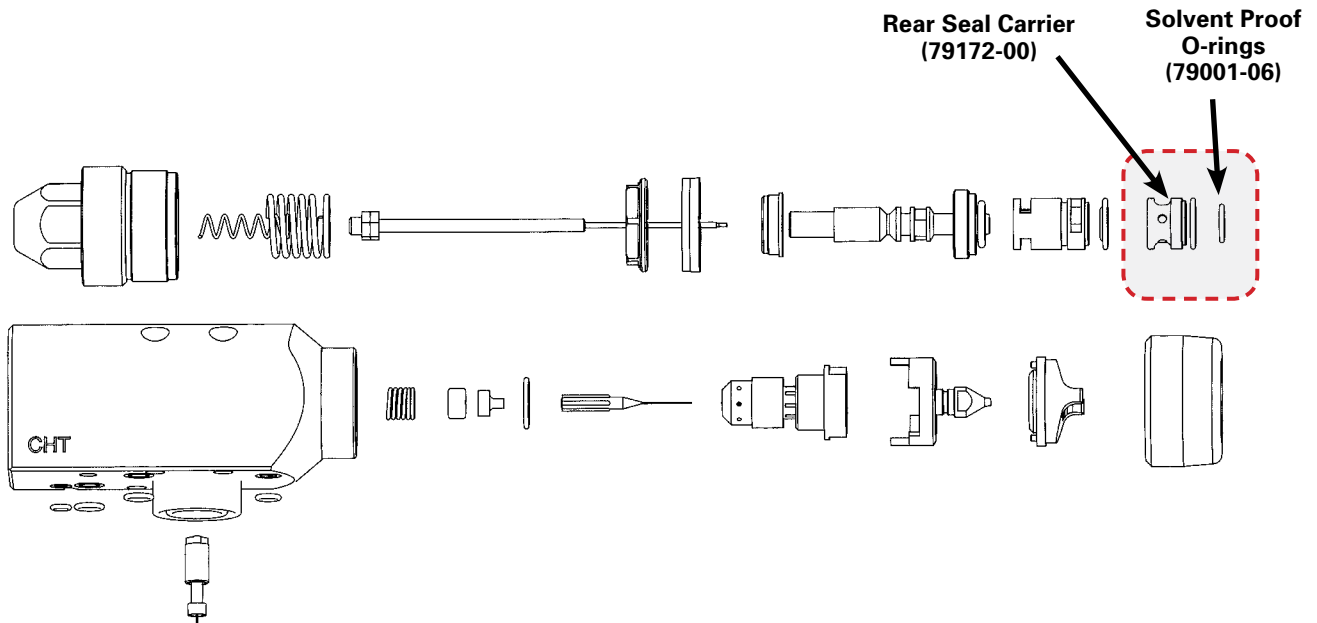

Step 21

Slide the seal carrier out of the spray head.

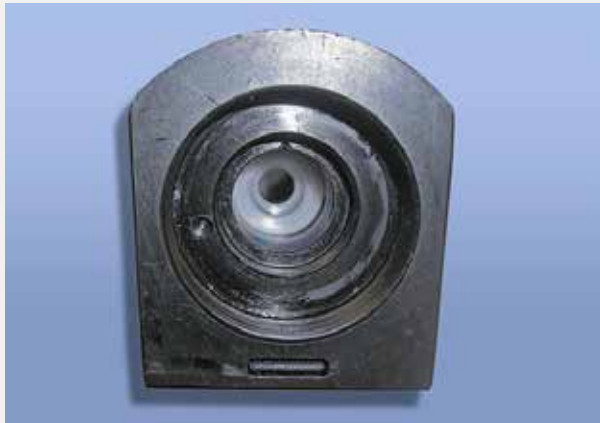

Step 22

Slide the seal carrier out of the spray head.



SPRAY HEAD DISASSEMBLY (Cont.)

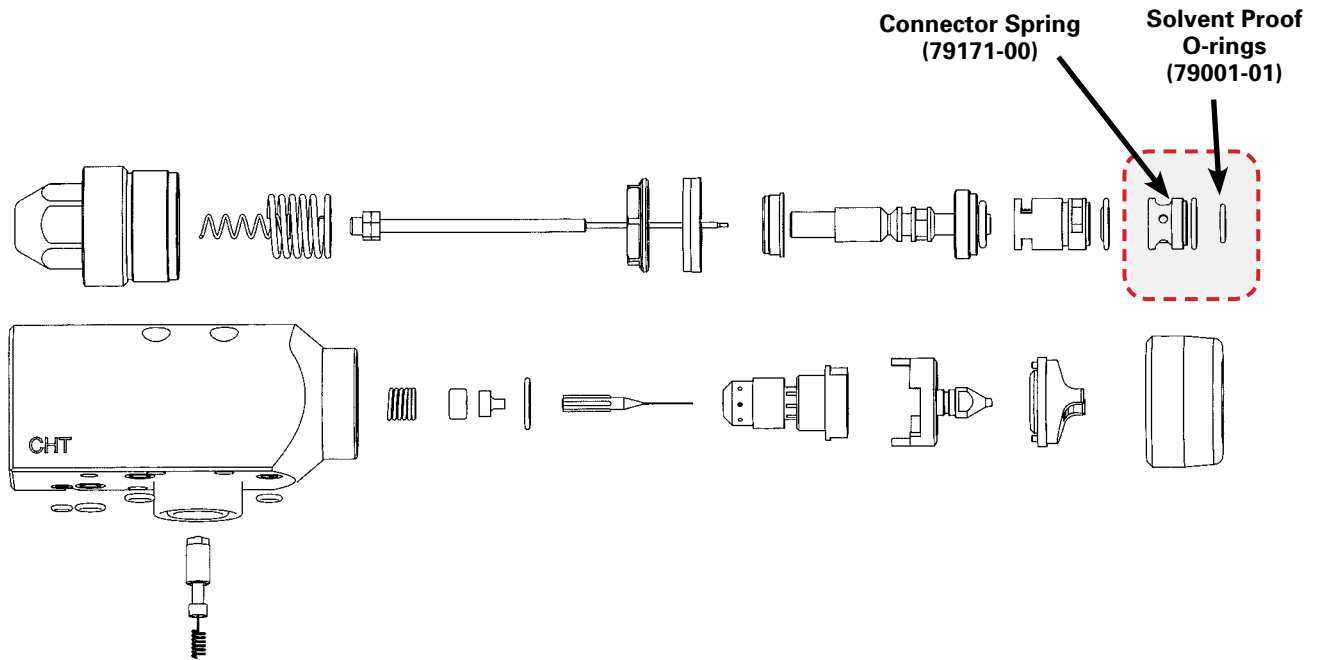

Step 23

Remove the o-ring from the spray head.



Step 24

Remove the high voltage contact spring from the spray head.



SPRAY HEAD DISASSEMBLY (Cont.)

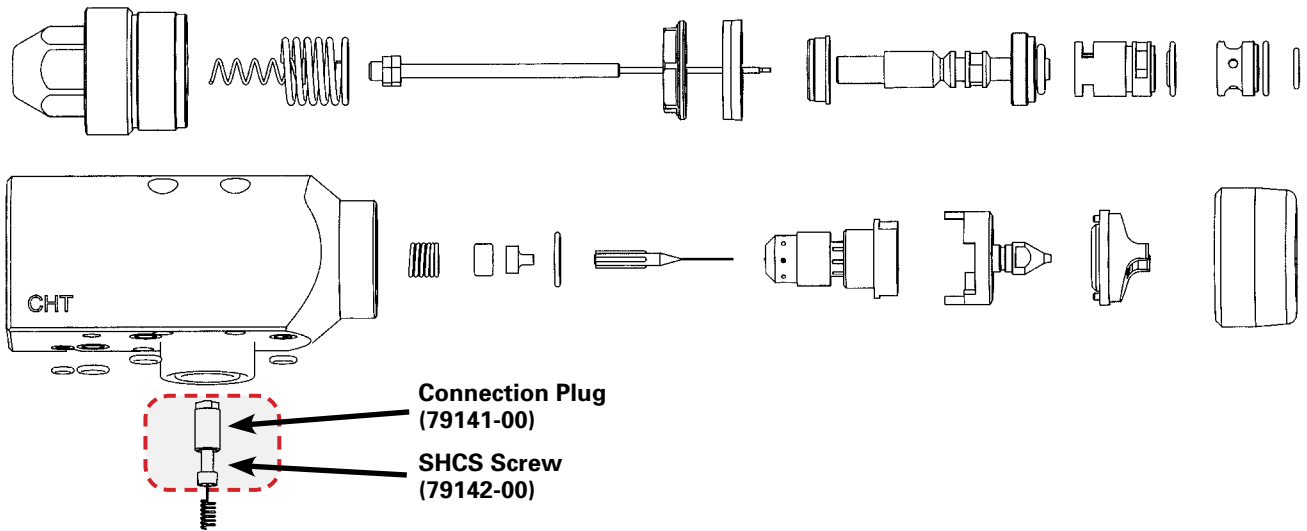

Step 25

Remove the socket head cap screw holding the connection plug.

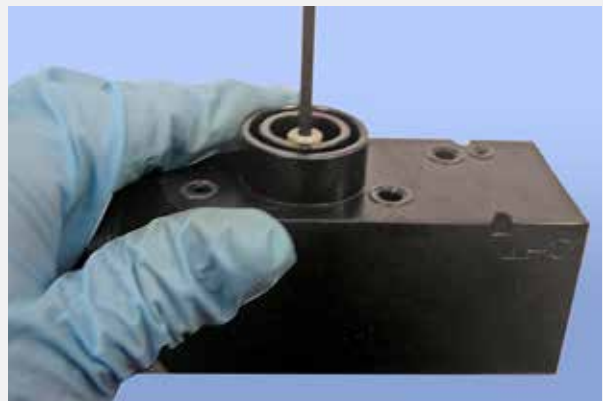

Step 26

Remove the connection plug from the spray head.



SPRAY HEAD REASSEMBLY

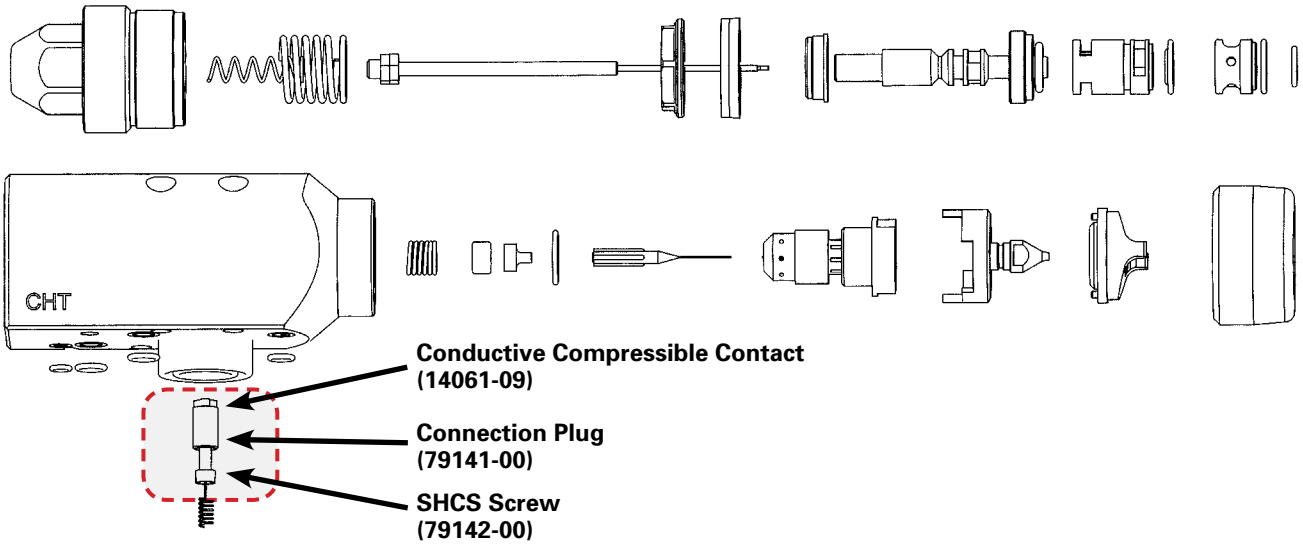

Step 1

If present, skip step1 cut .820 length of SSW-1125 and insert into hole. Form to ID of gun head while clearing central hole.



Step 2

Install the conductive sponge (if removed) and the connection plug into the spray head.



Step 3

Install and tighten the socket head cap screw:
 • Torque the screw to 5 lbs.-in. (0.56 Nm).

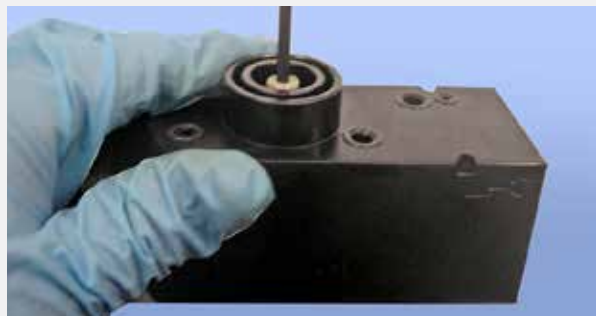

SPRAY HEAD REASSEMBLY (Cont.)

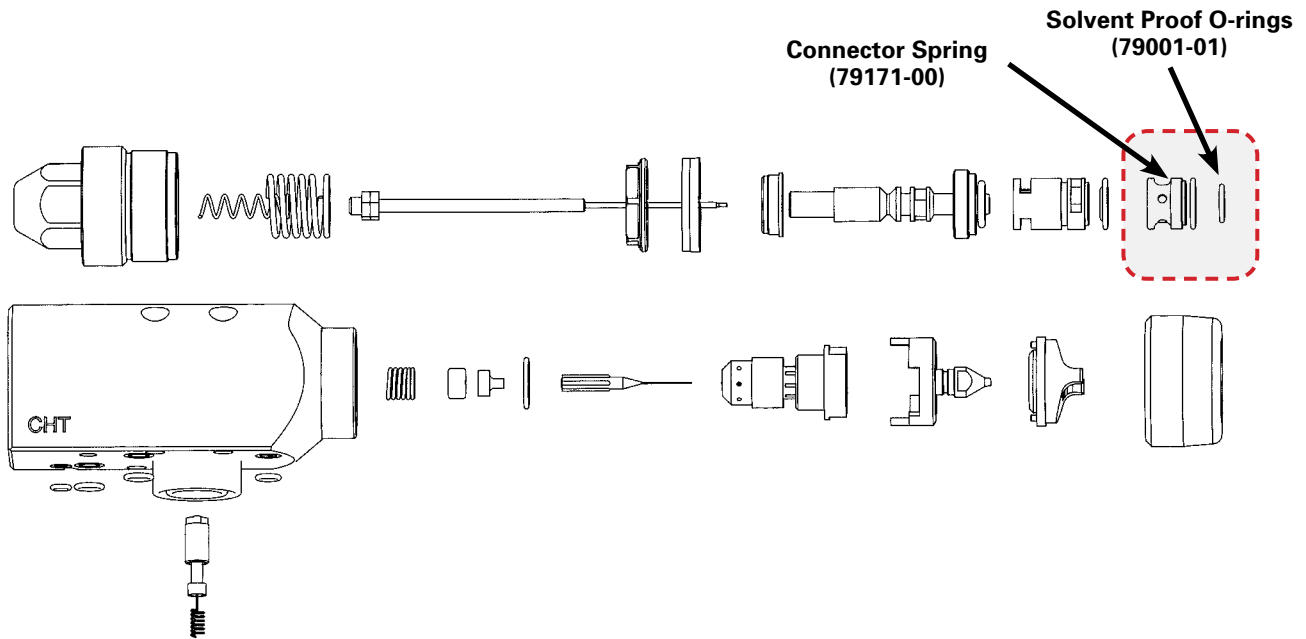

Step 4

Insert the high voltage contact spring into the spray head.

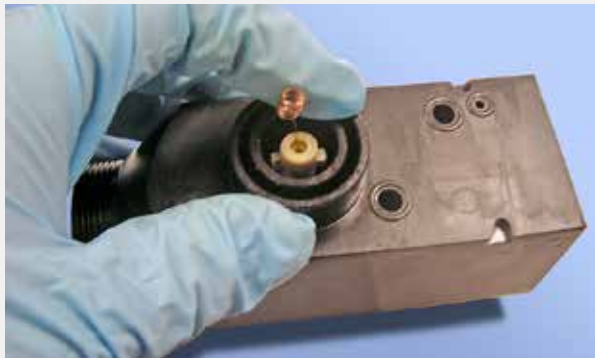

Step 5

Install the o-ring into the spray head:

- Push all of the way to the bottom.
- Apply a thin layer of petroleum jelly to the o-ring.



SPRAY HEAD REASSEMBLY (Cont.)

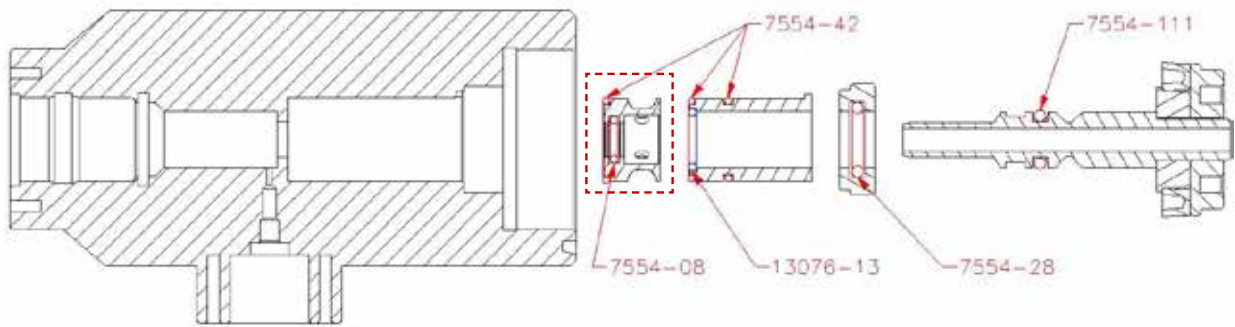

Step 6

Install the o-ring into the seal carrier:

- Apply a thin layer of petroleum jelly to the o-ring.



Step 7

Install the seal carrier into the spray head:

- Push all of the way to the bottom.



SPRAY HEAD REASSEMBLY (Cont.)

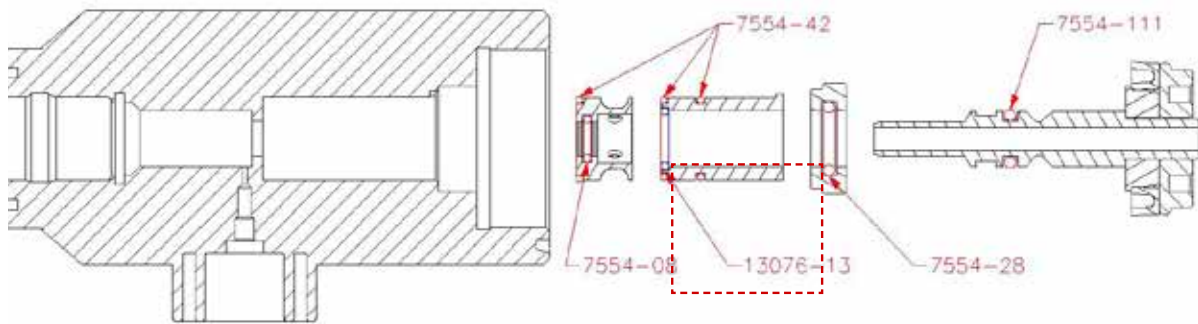

Step 8

Install the o-ring into the spray head:

- Push all of the way to the bottom.
- Apply a thin layer of petroleum jelly to the o-ring.



Step 9

Install the two o-rings onto the bushing:

- White PTFE o-ring (shuts OFF the fan air).
- O-ring (keeps fan and atomization air separated).
- Apply a thin layer of petroleum jelly to the o-ring.



SPRAY HEAD REASSEMBLY (Cont.)

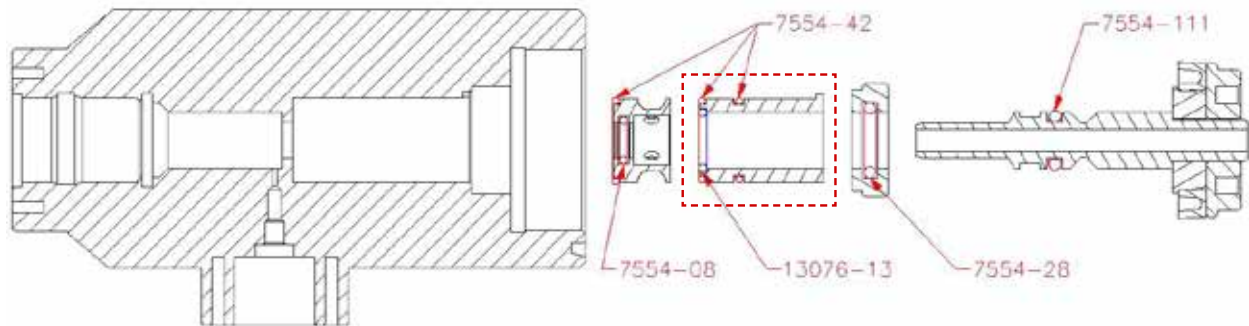

Step 10

Install the bushing into the spray head.



Step 11

Ensure that the alignment pin is in the correct position.



SPRAY HEAD REASSEMBLY (Cont.)

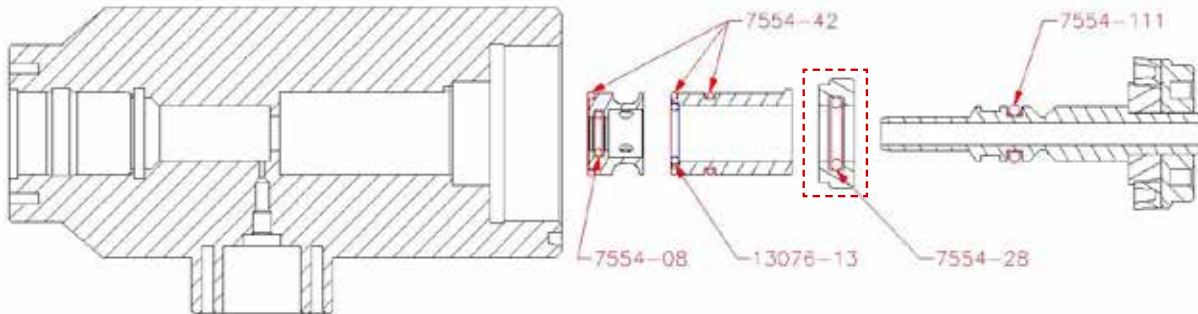

Step 12

Install the o-ring into the seal retainer. This o-ring separates cylinder air and atomization air. Apply a thin layer of petroleum jelly to the o-ring.

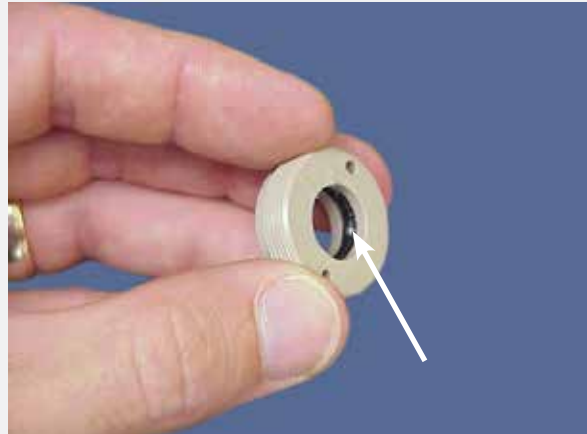
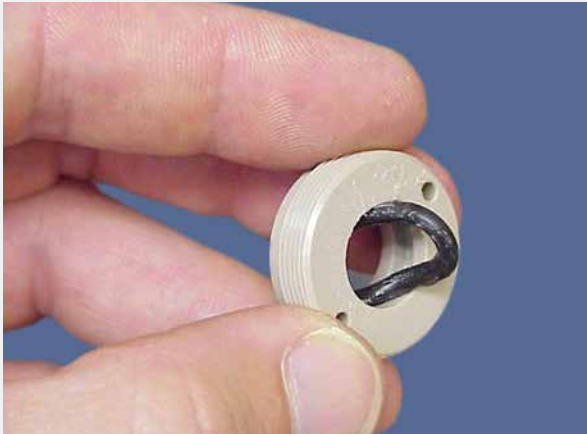

Step 13

Using the seal carrier tool, install the seal retainer into the spray head:

- Torque to 30-35 lbs.-in. (3.4-4.0 Nm) If not properly torqued, the atomization and fan air may equalize resulting in lack of fan control.

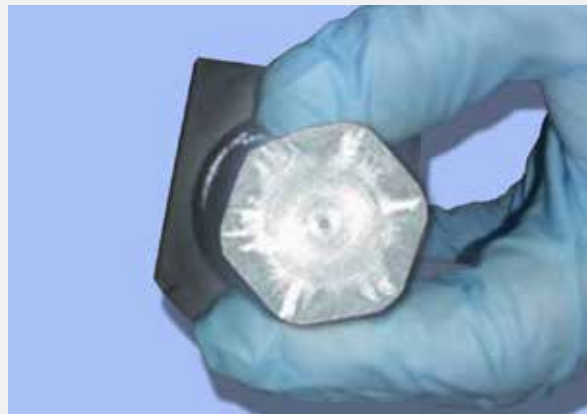
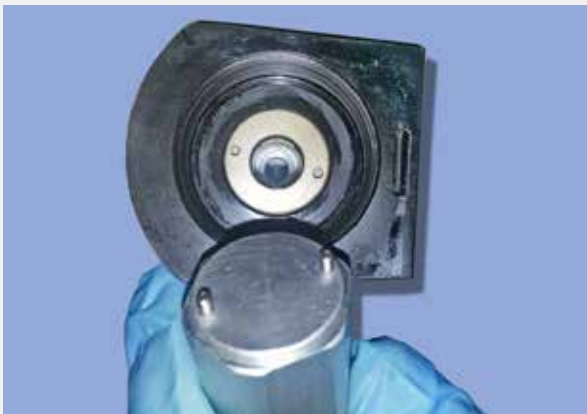

SPRAY HEAD REASSEMBLY (Cont.)

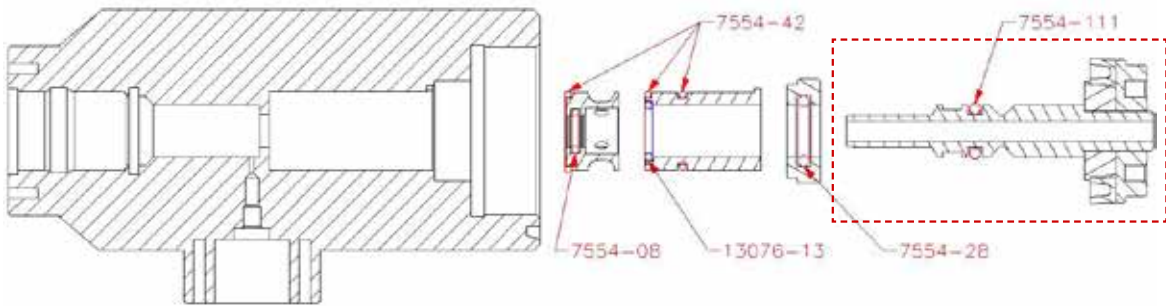

Step 14

Install the o-ring onto the air valve shaft. This o-ring separates fan and atomization air. Apply a thin layer of petroleum jelly to the o-ring.

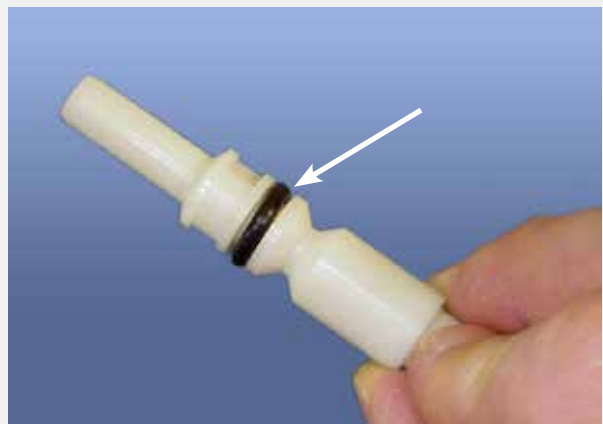

Step 15

Insert the piston plate into the piston u-cup:

- Will leak trigger air out the vent hole in the rear cap if bad.



SPRAY HEAD REASSEMBLY (Cont.)

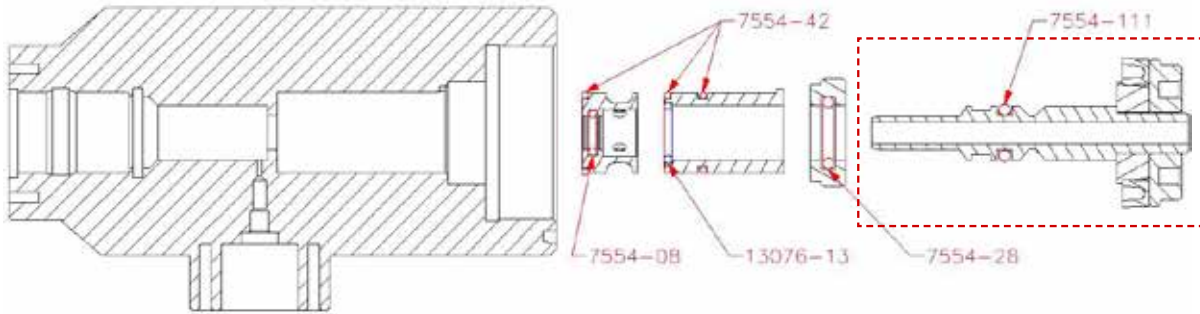

Step 16

Install the piston nut.



Step 17

Slide the piston assembly into the spray head.

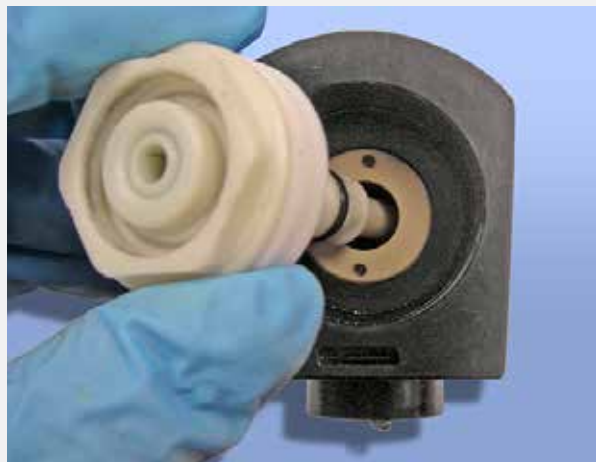

SPRAY HEAD REASSEMBLY (Cont.)

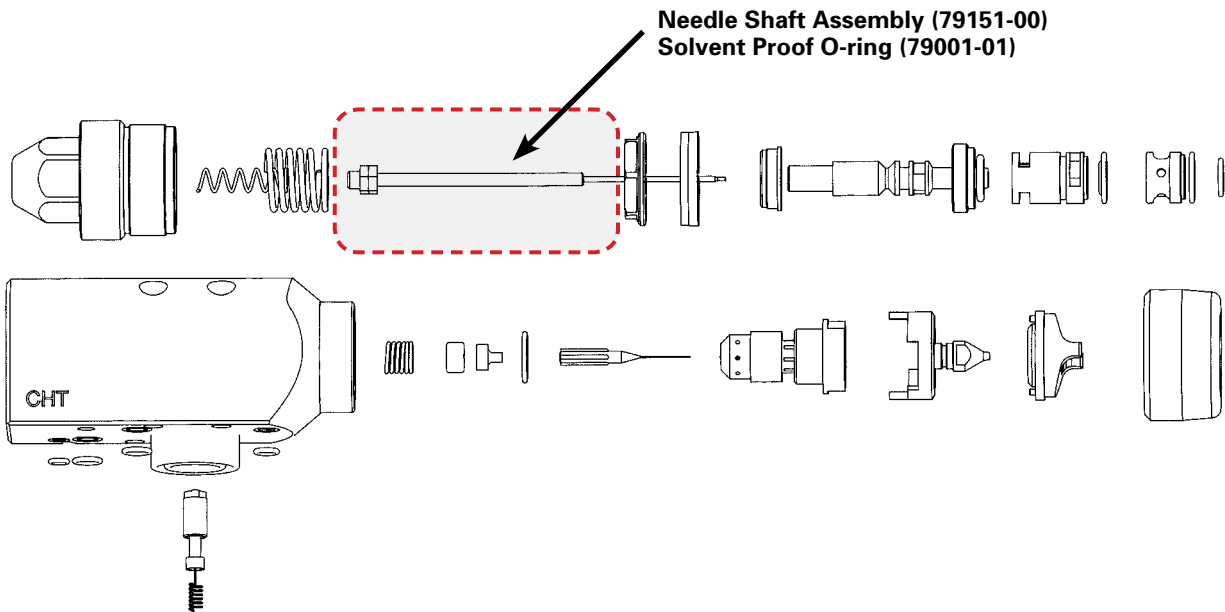

Step 18

Loosely install the air valve adjustment nut and jam nut onto the needle shaft:

- The air valve adjustment nut should be approximately flush with the end of the needle shaft.



Step 19

Install the rear needle assembly into the spray head.



SPRAY HEAD REASSEMBLY (Cont.)

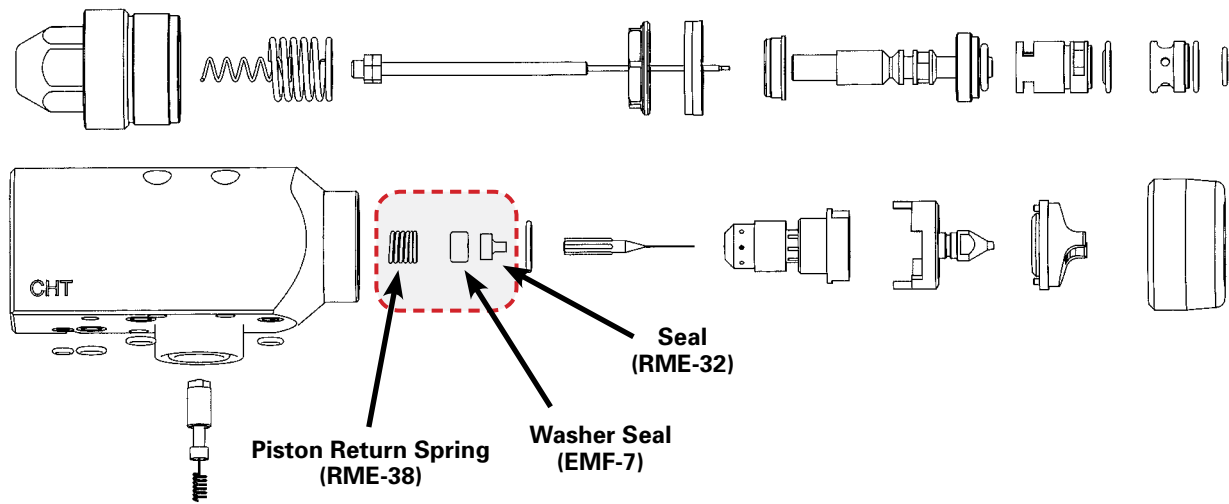

Step 20

Install the spring, seal washer, and fluid seal onto the needle shaft.



Step 21

Install the o-ring into the spray head. Push the o-ring all the way to the shoulder.

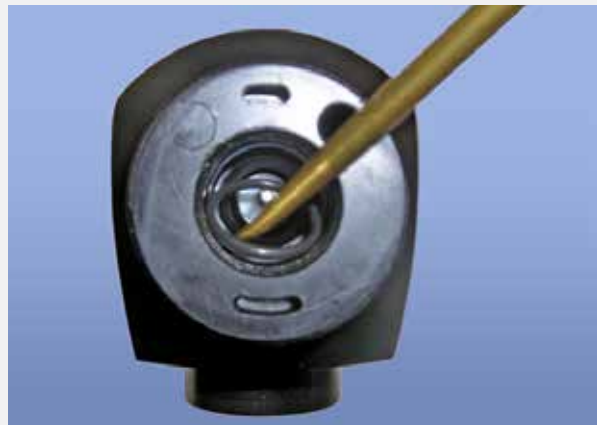

SPRAY HEAD REASSEMBLY (Cont.)

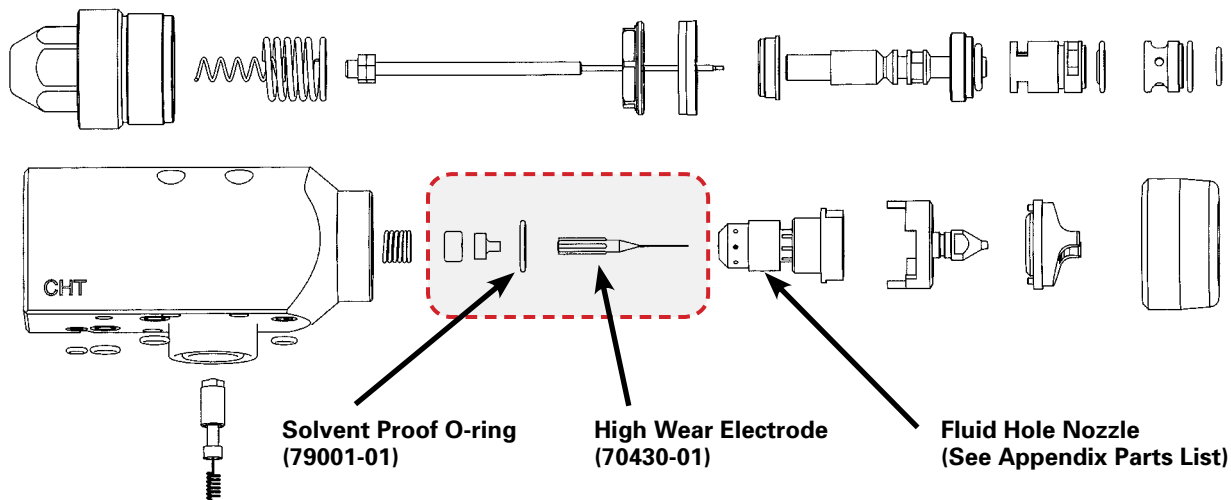

Step 22

Install the fluid nozzle:

- Torque fluid nozzle to 23-25 lbs.-in. (2.6-2.8 Nm).
- Apply a thin layer of petroleum jelly to the o-ring and threads on the fluid nozzle assembly.



Step 23

Install the electrode:

- Use low strength thread lock.



SPRAY HEAD REASSEMBLY (Cont.)

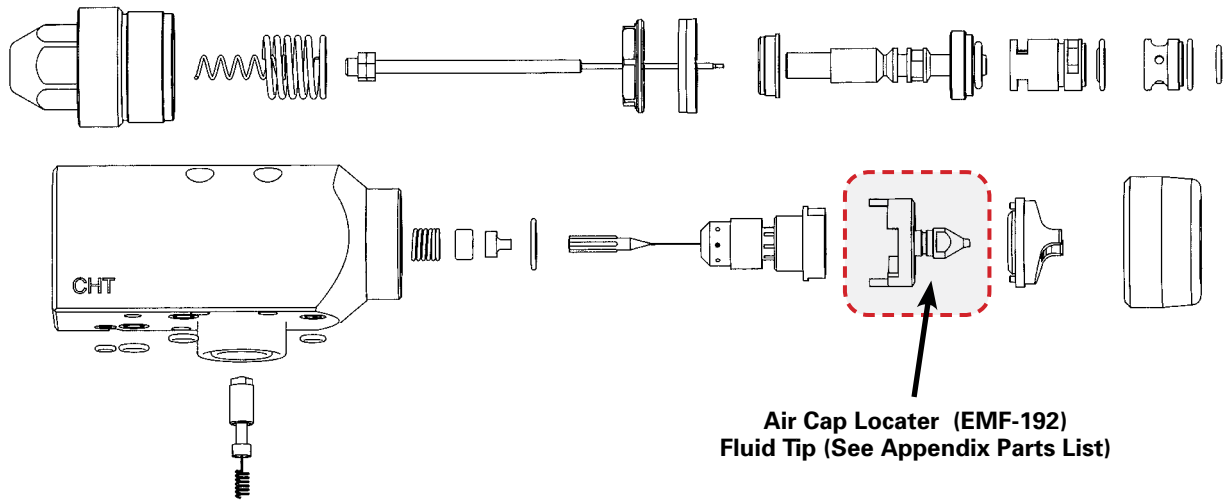

Step 24

Install the fluid tip (hand tight plus 30°).



Step 25

Install the air cap locating ring.



SPRAY HEAD REASSEMBLY (Cont.)

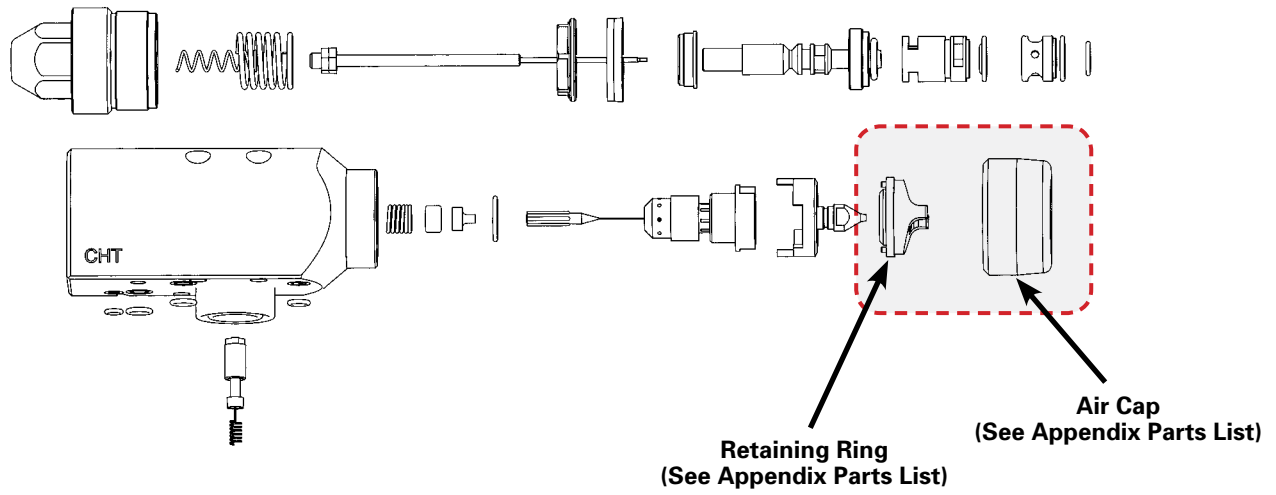

Step 26

Install the air cap and the air cap retaining ring.

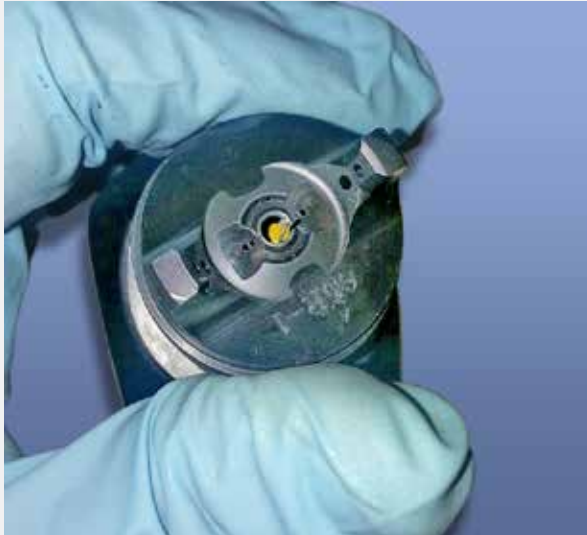

SPRAY HEAD REASSEMBLY (Cont.)

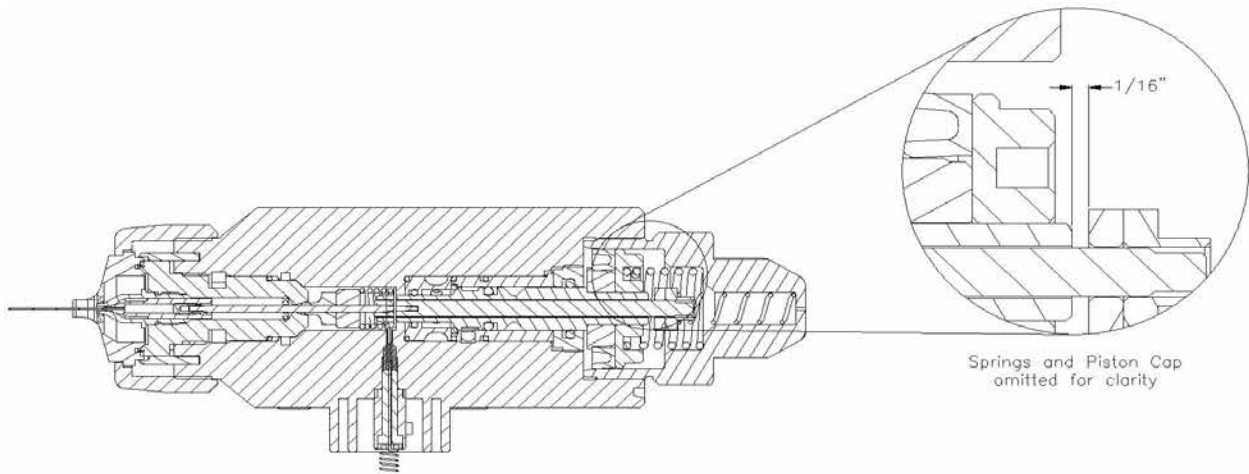

Step 27

With the electrode seated in the fluid tip, measure the distance between the jam nut and the piston assembly.

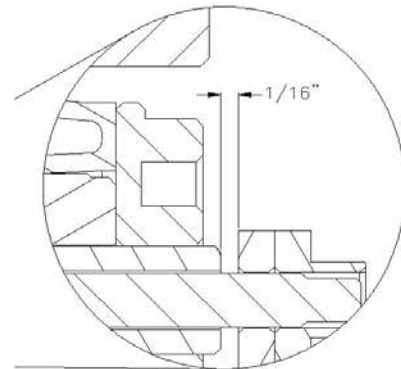

Springs and Piston Cap omitted for clarity

Step 28

Tighten the air valve adjustment nut to the jam nut when 1/16" is measured.

Re-check measurement.

This adjustment ensures that atomization and fan air are ON before the fluid needle is engaged.

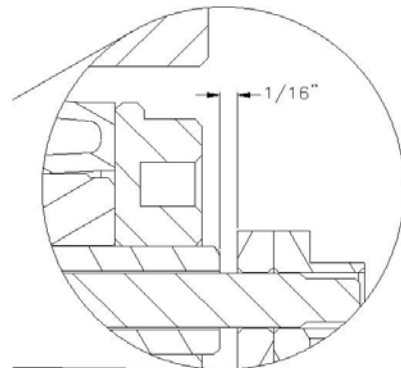

Springs and Piston Cap omitted for clarity

SPRAY HEAD REASSEMBLY (Cont.)

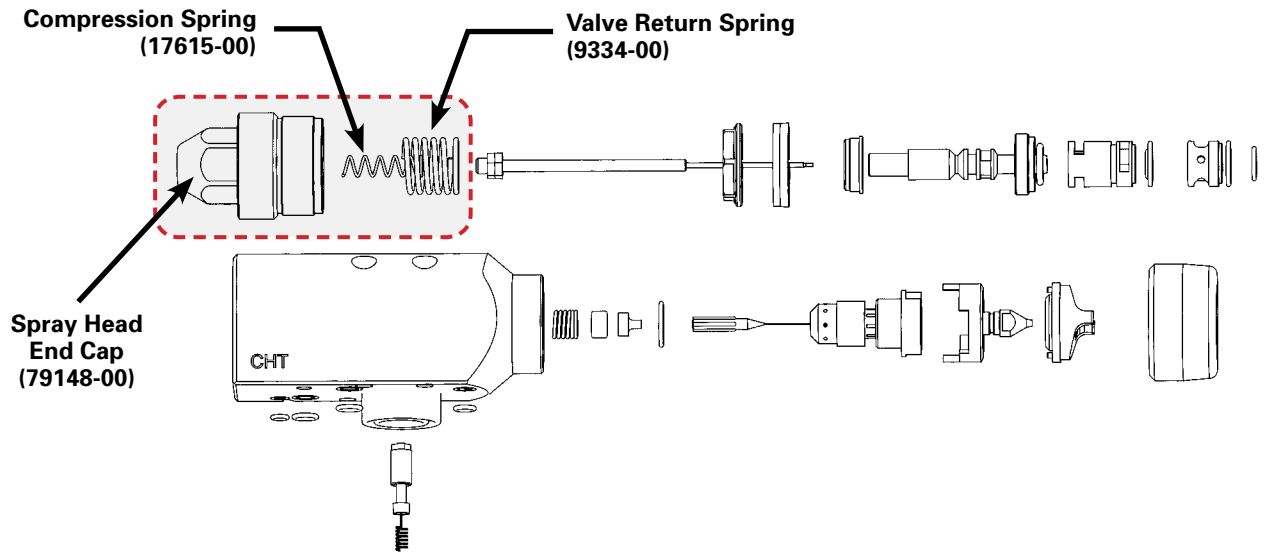

Step 29

Install the piston and needle return springs.



Step 30

Apply a thin layer of petroleum jelly to the piston cap threads. Install the piston cap.

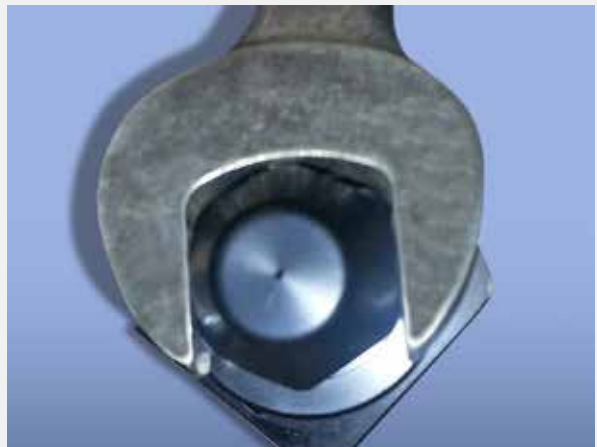

SPRAY HEAD ASSEMBLY (Installation)

Step 1

Apply dielectric grease into the labyrinth of the spray head.

Apply a thin layer dielectric grease onto the o-rings before installing the spray head.

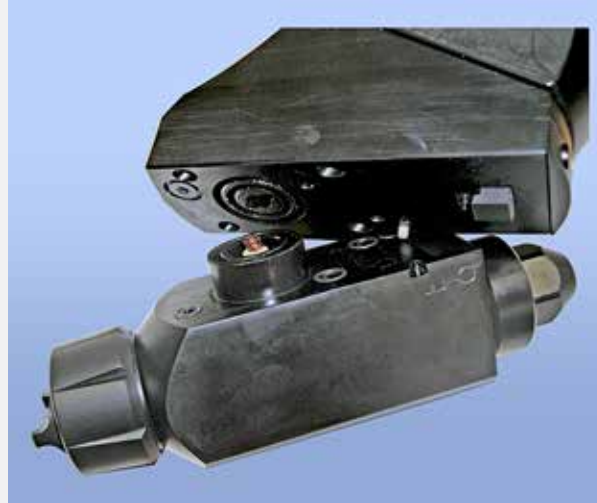

GUN HEAD IDENTIFICATION

All gun heads carrying the letters “CHT” are designed to be used with any atomization technology available for the Evolver, Conventional, HVLP, or Trans-Tech. Only gun heads marked “CHT” are capable of this change. See **figure below** for clarity.

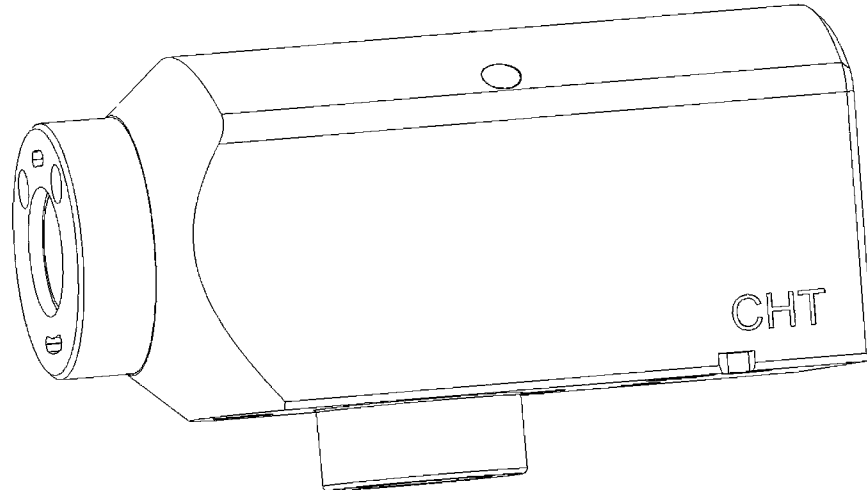

CHT Identification

TOOL CENTER POINT DRAWINGS

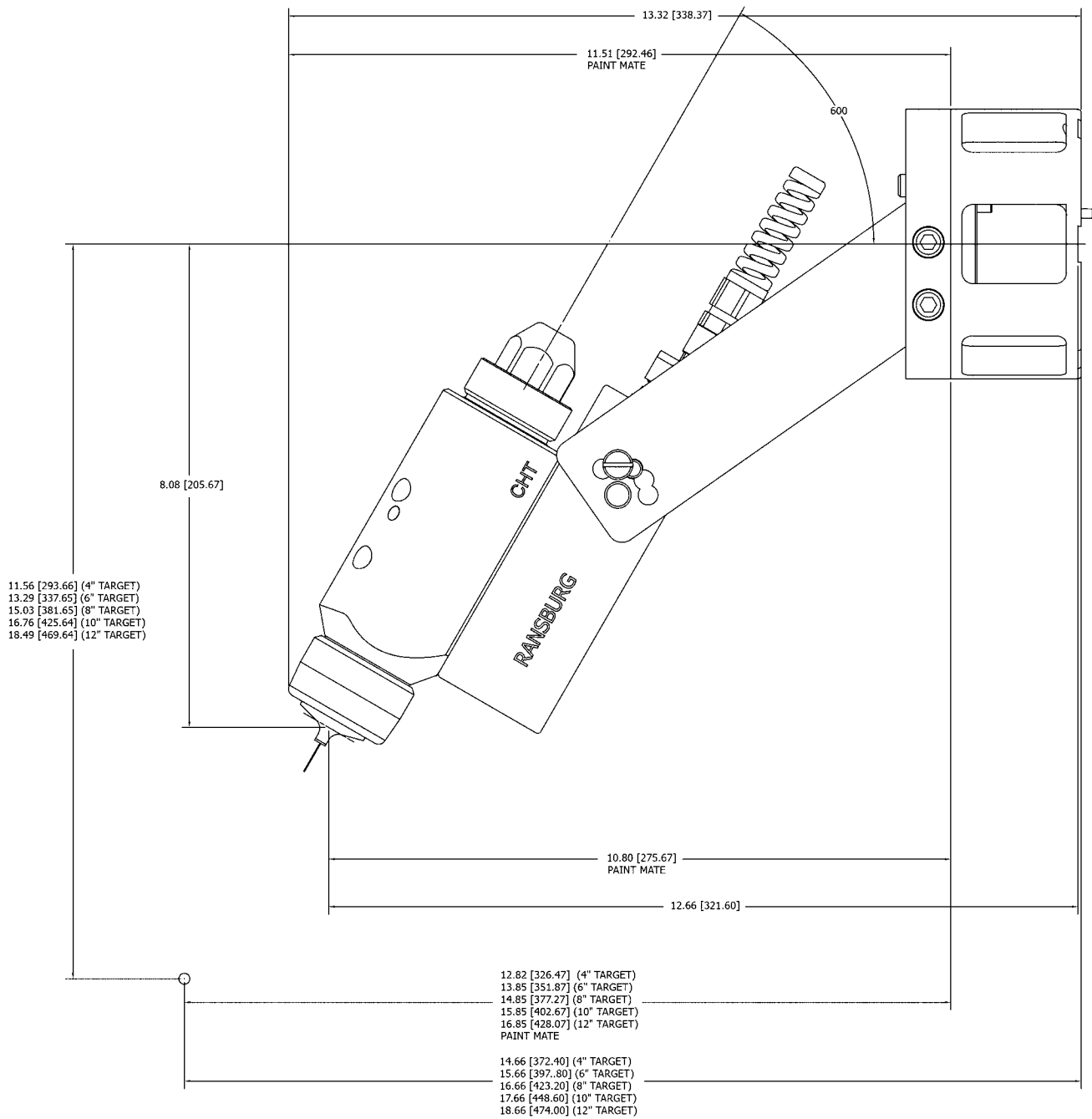

TOOL CENTER POINT DRAWINGS (Cont.)

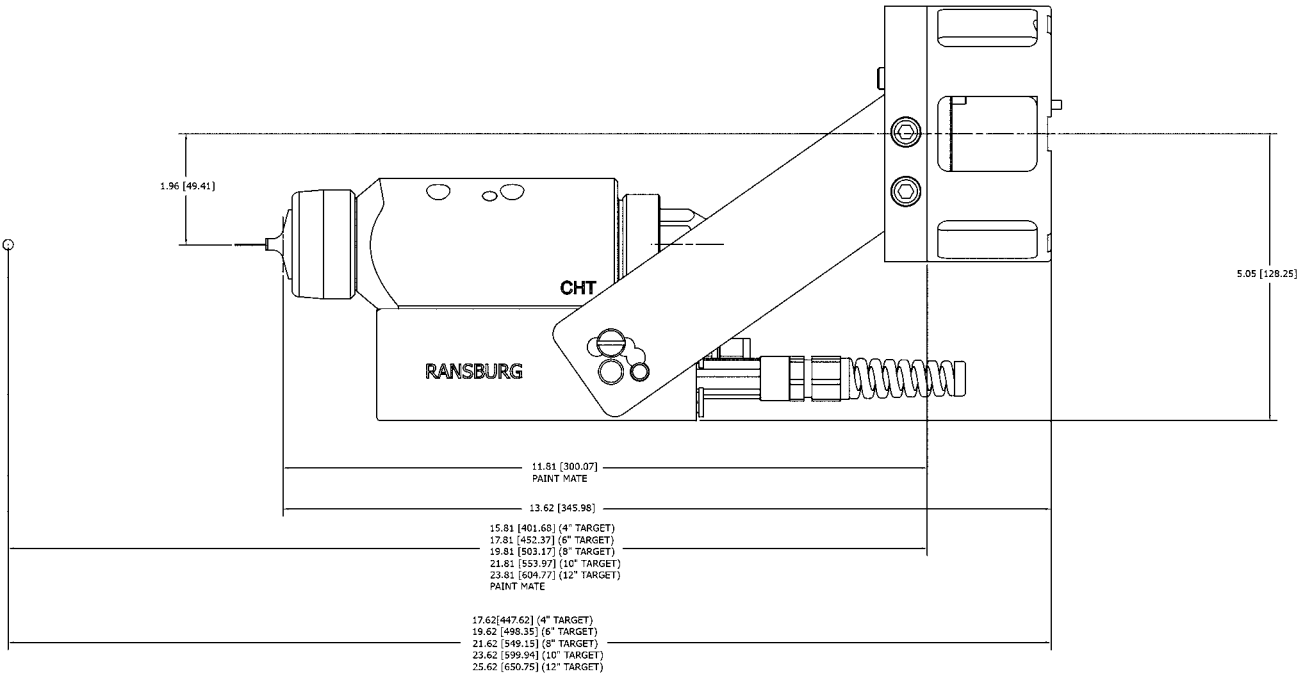

TOOL CENTER POINT DRAWINGS (Cont.)

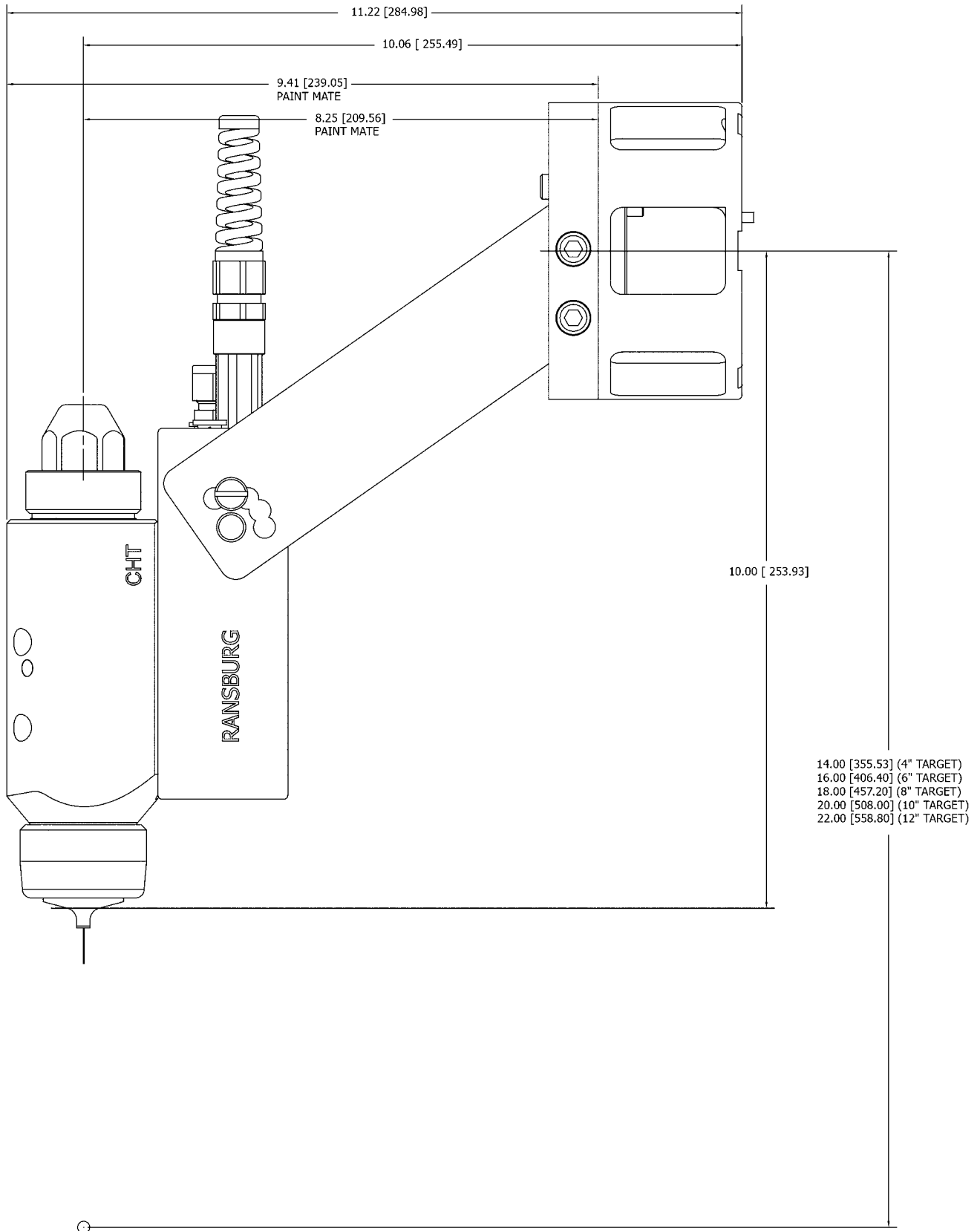

TOOL CENTER POINT DRAWINGS (Cont.)

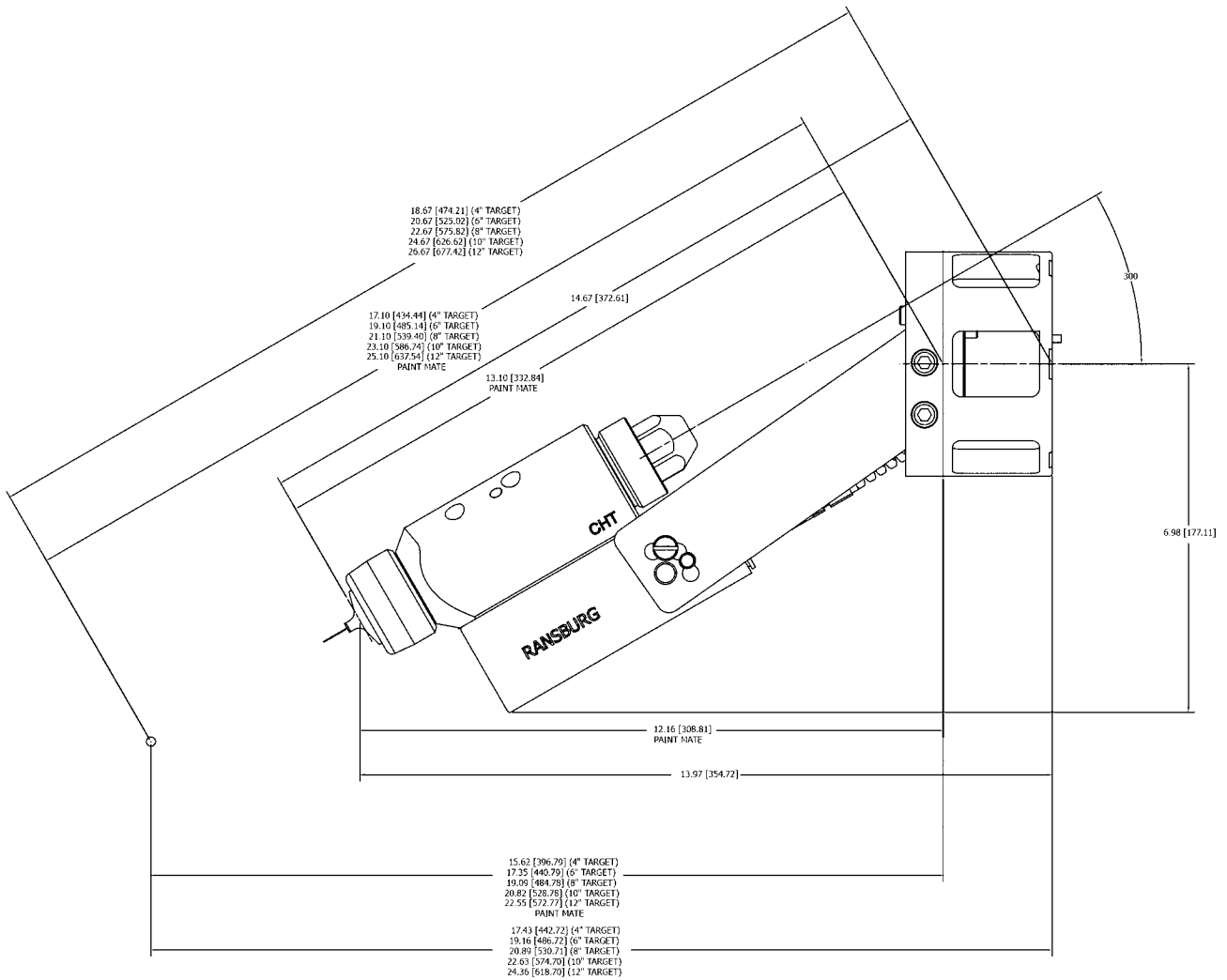

TOOL CENTER POINT DRAWINGS (Cont.)

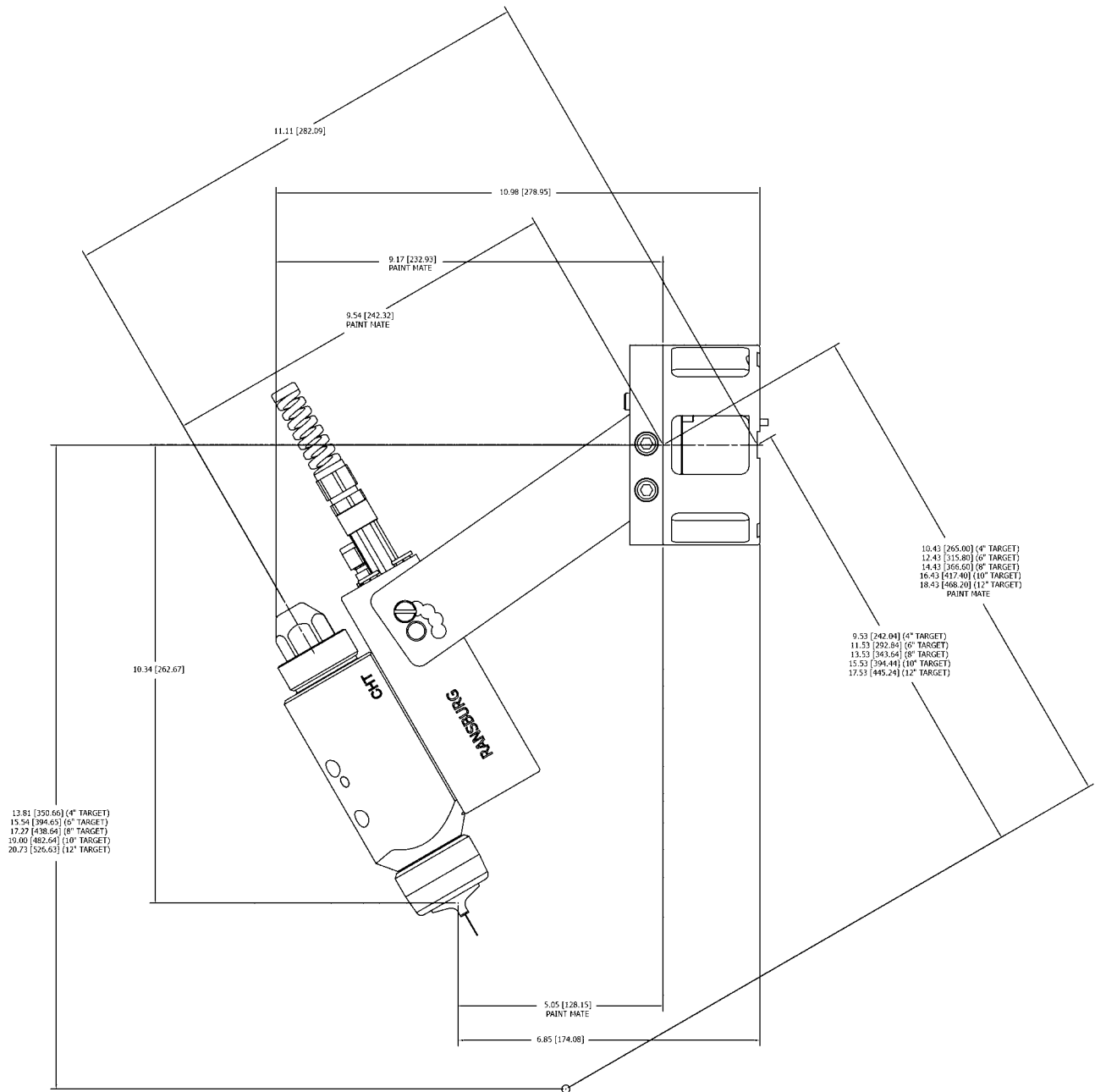

PARTS IDENTIFICATION

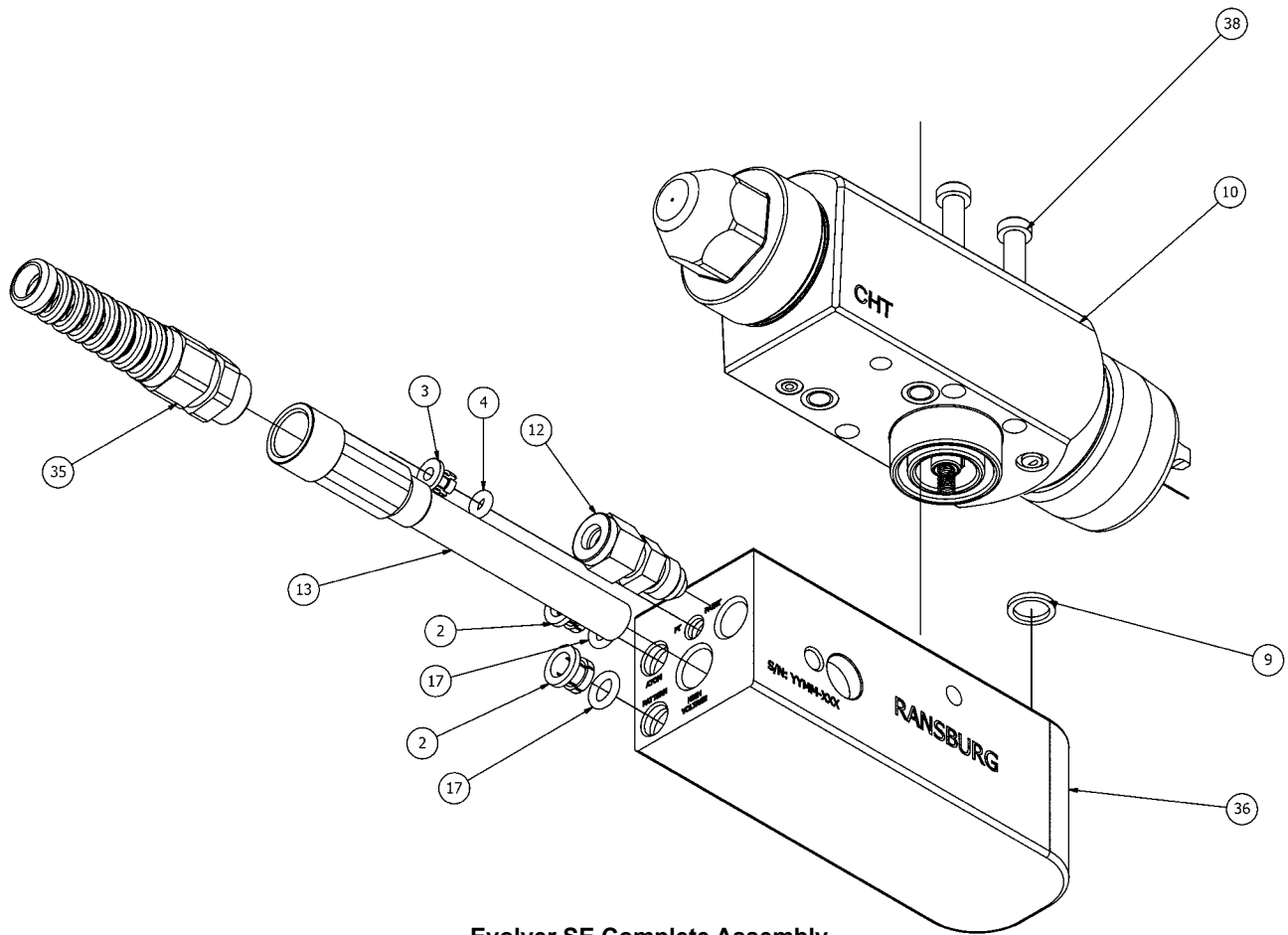

Evolver SE Complete Assembly

EVOLVER SE COMPLETE ASSEMBLY PARTS LIST			
Item	Qty.	Part No.	Description
17	2	tsk2111	O-RING, SOLVENT PROOF
2	2	77762-04	COLLET, 8 MM
3	1	77516-04	COLLET, 4 MM
4	1	79001-30	O-RING, SOLVENT PROOF SQUARE CUT RING (KALREZ)
9	1	A10612-00	
10	1	A12630	HEAD ASS'Y, EVOLVER SE
12	1	LSFI0022-05	FITTING
13	1	80080-00	TUBE, HIGH VOLTAGE W/STRAIN RELIEF
35	1	80079-00	STRAIN RELIEF, M16 X 1.5
36	1	A13867	BODY ASSEMBLY
38	4	LSFA0004-48CB	SCREW, FILLISTER HEAD (1/4-20 X 1.50) BLACK

EVOLVER SE MODEL IDENTIFICATION

When ordering, use A13901-AABCDEFGG as indicated by Tables AA, B, C, D, E, F and G.
Eight (8) digits must follow the basic part number.

For Example:

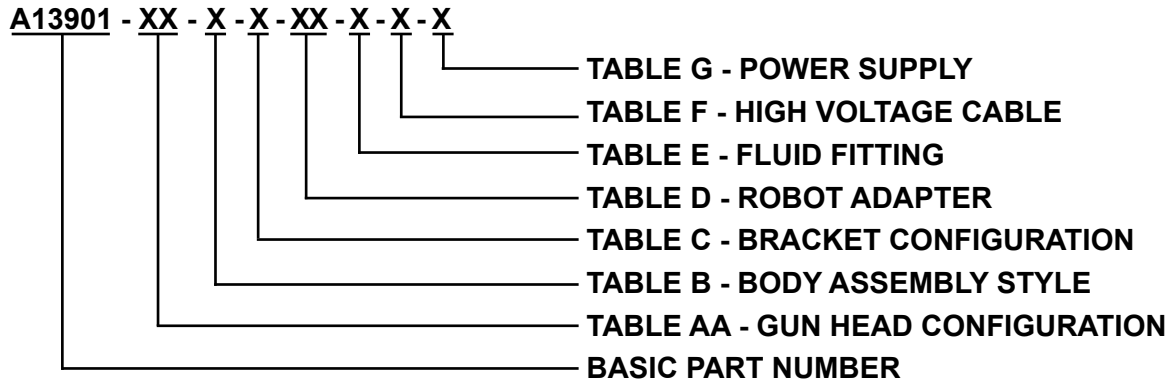

TABLE AA - GUN HEAD CONFIGURATION		
Dash #	“C”	Description
00	---	NONE
01	A13856-01	CONVENTIONAL/NON-BLEED SPRAY GUN HEAD (.055” TIP, 1.4MM)
03	A13856-03	CONVENTIONAL BLEED SPRAY GUN HEAD (.055” TIP, 1.4MM)
21	A13856-21	TRANS-TECH/BLEED SPRAY GUN HEAD (.055” TIP, 1.4MM)
22	A13856-22	TRANS-TECH/NON-BLEED SPRAY GUN HEAD (.055” TIP, 1.4MM)

TABLE B - BODY ASSEMBLY STYLE				
Dash #	“A”	“B”	“E”	Description
0	---	---	---	NONE
1	A13867-00	1	1	NON-RECIRCULATING BODY ASSEMBLY
2	A13868-00	2	1	RECIRCULATING BODY ASSEMBLY
3	A13873-00	1	2	NON-RECIRCULATING BODY ASSEMBLY WITH DUMP VALVE BLOCK

TABLE C - BRACKET CONFIGURATION			
Dash #	Bracket Ass’y “M”	Robot Adapter	Description
0	---	---	NO BRACKET
1	A12552-01	NONE	PAINT MATE ROBOT
2	A12553-01	TABLE D ITEM “D”	HOLLOW WRIST ROBOT
3	A12554-01	NONE	STATIONARY OR POLE MOUNT

TABLE D - ROBOT ADAPTER			
Dash #	Description	“B”	Notes
00	ADAPTER NOT INCLUDED	N/A	
01	FANUC P145/P155	78983-00	STANDARD LENGTH WITH WINDOWS
02	ABB 5400, 5002	79107-00	STANDARD LENGTH WITH WINDOWS
03	FANUC P200/P250	79131-00	STANDARD LENGTH WITH WINDOWS
04	KAWASAKI KE610L	A10847-00	STANDARD LENGTH WITH WINDOWS
05	MOTOMAN PX2850	A10848-00	STANDARD LENGTH WITH WINDOWS
06	MOTOMAN PX2900	A10849-00	STANDARD LENGTH WITH WINDOWS
07	B&M LZ2000	A10851-00	STANDARD LENGTH WITH WINDOWS
08	ABB 5400 ENHANCED WRIST	A12036-00	STANDARD LENGTH WITH WINDOWS
09	MOTOMAN EPX2050	A13697-00	STANDARD LENGTH WITH WINDOWS
10	FANUC P200-P250	A13733-00	EXTENDED LENGTH WITH 1 WINDOW
11	KAWASAKI KE610L	A13734-00	EXTENDED LENGTH WITH 1 WINDOW
12	ABB 5400 ENHANCED WRIST	A13735-00	EXTENDED LENGTH WITH 1 WINDOW
13	MOTOMAN EPX2050	A13736-00	EXTENDED LENGTH WITH 1 WINDOW
14	MOTOMAN EPX2900	A13765-00	EXTENDED LENGTH WITH 1 WINDOW

TABLE E - FLUID FITTING TYPE		
Dash #	“J”	Description
0	---	---
1	LSFI0022-05	FITTING 8M OR 5/16 O.D. TUBE
2	A12543-00	FITTING 3/8 O.D. TUBE (HIGH CONDUCTIVE MATERIAL)

TABLE F - HIGH VOLTAGE CABLE						
Dash #	“P”	Description	“R”	“S”	“V”	“X”
0	---	---	---	---	---	---
1	A10560-25D	25 FT LONG (7.6 METERS)	-421	-621	-121	-321
2	A10560-50D	50 FT LONG (15.2 METERS)	-431	-631	-131	-331
3	A10560-75D	75 FT LONG (22.8 METERS)	-441	-641	-141	-341

TABLE G - POWER SUPPLY						
App.	“Q”	Pneumatic Module	Remote Manifold	Description	“I”	“U”
0	---	---	---	---	0	0
1	80100-211	---	---	9060 POWER SUPPLY - DOMESTIC – 110/120 VOLT– INTERNAL CASCADE	1	1
2	80100-213	---	---	9060 POWER SUPPLY - CHINA – 220/240 VOLT– INTERNAL CASCADE	1	1
3	80146-“R”	80112-00	76791-12	9060 POWER SUPPLY– DOMESTIC – OIL FILLED EXTERNAL CASCADE– PNEUMATIC MODULE	0	0
4	80146-“S”	80112-00	76791-12	9060 POWER SUPPLY– CHINA- OIL FILLED EXTERNAL CASCADE– PNEUMATIC MODULE	0	0
5	80146-“R”	NONE	---	9060 POWER SUPPLY ONLY DOMESTIC – OIL FILLED EXTERNAL CASCADE	0	0
6	80146-“S”	NONE	---	9060 POWER SUPPLY ONLY – CHINA OIL FILLED EXTERNAL CASCADE	0	0
7	80146-“V”	NONE	---	9060 POWER SUPPLY– US 10” RACK OIL FILLED CASCADE	0	0
8	80146-“X”	NONE	---	9060 POWER SUPPLY– CHINA 10” RACK OIL FILLED CASCADE	0	0

EVOLVER SE PARTS LIST			
Item	Qty.	Part #	Description
1	1	TABLE B ITEM "A"	BODY ASSEMBLY
2	2	77762-04	COLLET, 8MM
3	TABLE B ITEM "E"	77516-04	COLLET, 4MM
4	TABLE B ITEM "E"	79001-30	O-RING, SOLVENT PROOF
6	1	LSF10004-00	SCREW, NYLON 1/4-20 X 1 1/2 LG
9	1	A10612-00	SQUARE CUT RING
10	1	TABLE AA ITEM "C"	HEAD ASS'Y, EVOLVER SE
11	2	79001-34	O-RING, SOLVENT PROOF
12	TABLE B ITEM "B"	TABLE E ITEM "J"	FITTING, FLUID
13	1	80080-00	HIGH VOLTAGE TUBE
14	---	---	---
15	---	---	---
16	---	---	---
17	---	---	---
18	"U"	TABLE F ITEM "P"	HIGH VOLTAGE CABLE (NOT SHOWN)
19	1	TABLE G ITEM "Q"	POWER SUPPLY WITH/WITHOUT MODULES
20	1	TABLE C ITEM "M"	MOUNTING BRACKET CONFIGURATION
21	1	TABLE D ITEM "D"	ROBOT ADAPTER (NOT SHOWN)
22	1	LSCH0009-00	DIELECTRIC GREASE (0.88 OZ. TUBE)
23	1	80079-00	STRAIN RELIEF, M16 X 1.5
24	"T"	80073-00	STRAIN RELIEF, CABLE GLAND
25	"T"	80074-00	COUPLING, CABLE
26	"T"	7296-00	NUT, CABLE PLUG
27	"T"	8521-06F	SCREW, SET
28	1	AA-15-01	SERVICE MANUAL

SPRAY HEAD ASSEMBLY

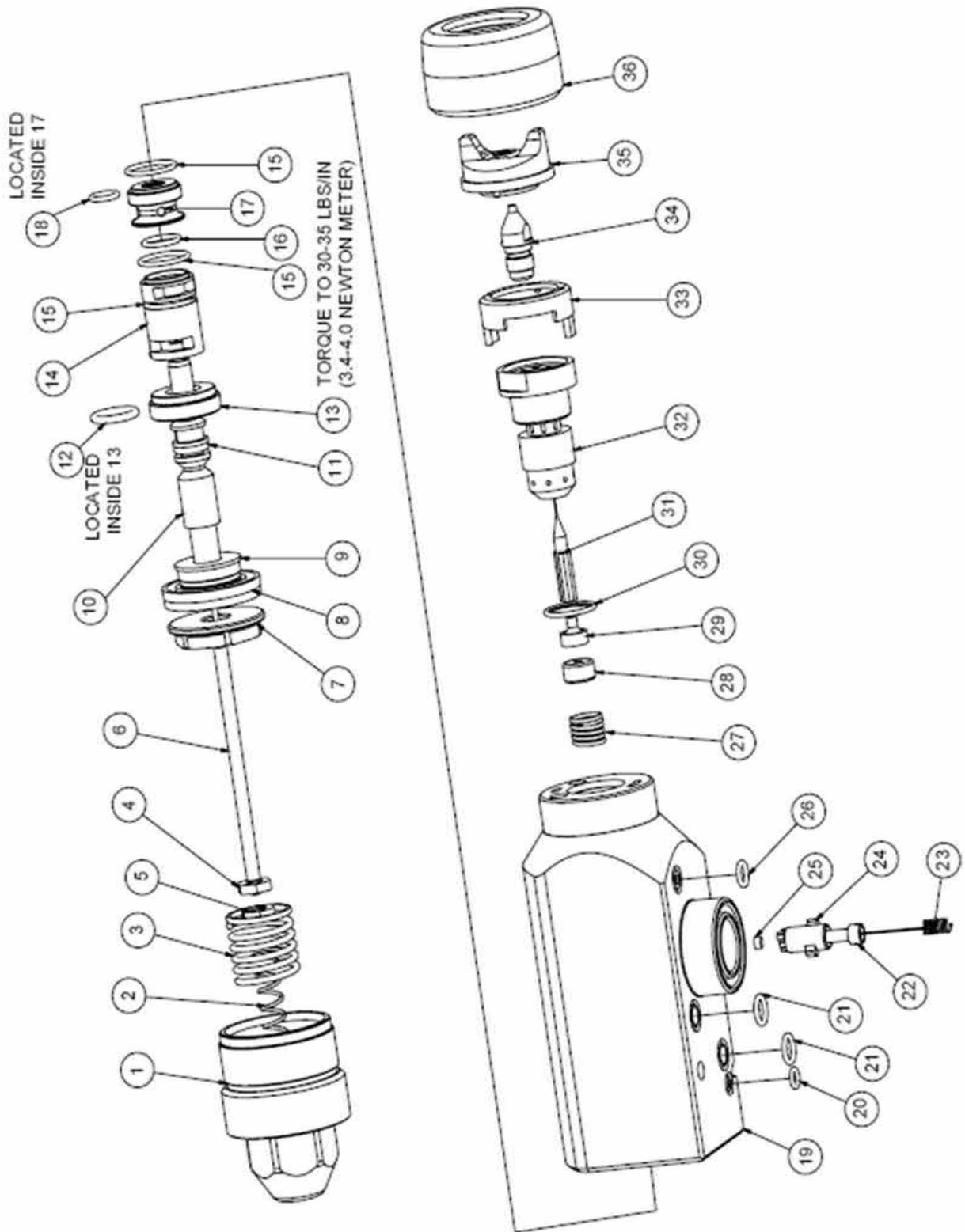

SPRAY HEAD ASSEMBLY PARTS IDENTIFICATION (See Pg 67):
CONVENTIONAL: A12630-01, -03, -85, -75
TRANS-TECH: A12630-21, -22, -43, -44

Item #	Part #	Description	Qty
1	79148-00	End Cap, Spray Head	1
2	17615-00	Spring, Compression	1
3	9334-00	Spring, Valve Return	1
4	7733-07	Nut, Jam	1
5	76199-00	Nut, Adjustment Rear	1
6	79151-00	Assembly, Needle Shaft	1
7	79147-00	Nut, Piston	1
8	7723-06	Piston, U-Cup	1
9	79145-00	Plate, Piston	1
10	79144-00	Shaft, Air Valve	1
11	79001-28	O-Ring, Solvent Proof	1
12	79001-29	O-Ring, Solvent Proof	1
13	79146-00	Seal Carrier, Rear Piston	1
14	79143-00	Bushing, Air Valve (Non-Bleed)	1
	79143-01	Bushing, Air Valve (Bleed)	1
15	79001-01	O-Ring, Solvent Proof	3
16	13076-13	O-Ring PTFE	1
17	79172-00	Carrier, Rear Seal (Non-Bleed)	1
	79172-01	Carrier, Rear Seal (Bleed)	1
18	79001-06	O-Ring, Solvent Proof	1
19	80403-01	Evolver Bare Gun Head Assembly Includes 22, 23, 24, 25, 37	1
20	79001-04	O-Ring, Solvent Proof	1
21	79001-06	O-Ring, Solvent Proof	2
22	79142-00	Screw, SHCS Included in 19	1
23	79171-00	Spring, Connector Included in 19	1
24	80404-00	Plug, Connection Included in 19	1
25	14061-09	Conductive Compressible Contact Included in 19	1
26	79001-05	O-Ring, Solvent Proof	1
27	RME-38	Return Spring, Piston	1
28	EMF-7	Seal, Washer	1
29	RME-32	Seal	1
30	79001-01	O-Ring, Solvent Proof	1
31	70430-01	Electrode, High Wear	1
32	EMF-195	Nozzle, Fluid	1
	80198-00	Nozzle, Fluid (Trans-Tech)	1
33	EMF-192	Locator, Air Cap	1

(Continued On Next Page)

SPRAY HEAD ASSEMBLY PARTS IDENTIFICATION (Cont.): CONVENTIONAL: A12630-01/04, 09/12 TRANS-TECH: A12630-07/08, 15/16			
Item #	Part #	Description	Qty
34	79140-01	Fluid Tip, .042" (1.07mm) Diameter	1
	79140-02	Fluid Tip, .055" (1.40mm) Diameter	1
	79140-03	Fluid Tip, .070" (1.78mm) Diameter	1
	80201-44	Fluid Tip, .055" (1.40mm) Diameter (Trans-Tech)	1
	80201-48	Fluid Tip, .047" (1.20mm) Diameter (Trans-Tech)	1
35	79153-65R-1	Air Cap, Certified 65R-1	1
	79196-98-1	Air Cap, Certified 98-1	1
	79197-63-1	Air Cap, Certified 63-1	1
	80194-00	Air Cap, Certified EV-40 (Trans-Tech)	1
36	79154-00	Ring, Retaining	1
	80199-00	Ring, Retaining (Trans-Tech)	1
37	SSW-1125	Wire Included in 19	1

DUMP MANIFOLD PARTS IDENTIFICATION

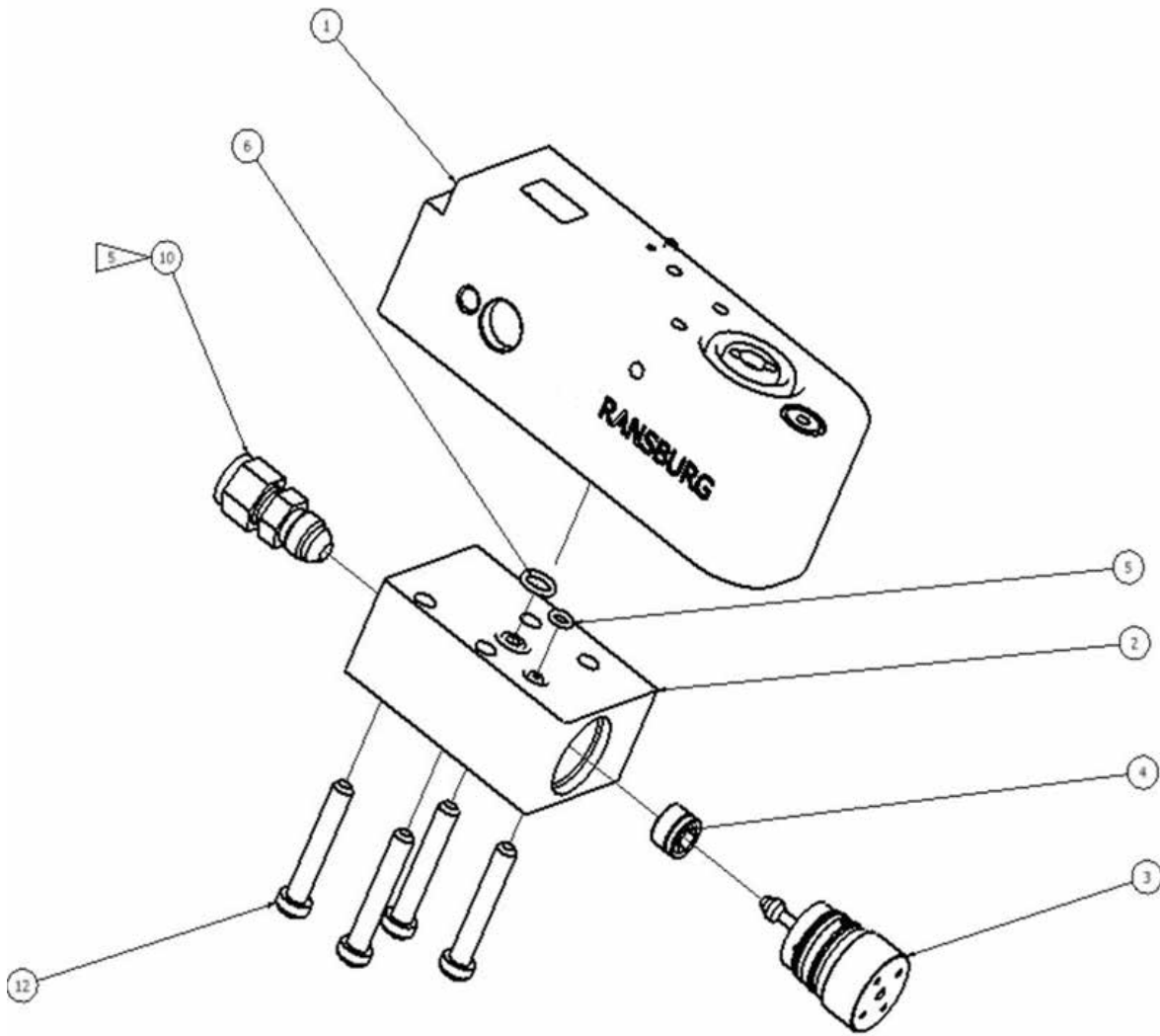

DUMP MANIFOLD PARTS LIST			
Item	Qty.	Part No.	Description
1	1	A13868-00	BODY ASSEMBLY
2	1	A12486-01	DUMP BLOCK
3	1	78949-00	VALVE ASSEMBLY (NON-REPAIRABLE)
4	1	77367-00	VALVE SEAT ASSEMBLY
5	1	79001-04	O-RING, SOLVENT PROOF
6	1	79001-06	O-RING, SOLVENT PROOF
8	1	LSFI0022-05	FITTING 5/16 TUBE TO "AN"
12	4	LSFA0004-48C	SCREW, FILLISTER HEAD (1/4 - 20 X 1.50)

HIGH VOLTAGE CABLE SELECTION PARTS IDENTIFICATION	
Part No.	Length
A10560-05	5 FT +/-3 IN
A10560-10	10 FT +/-3 IN
A10560-16	16 FT +/-3 IN
A10560-20 (standard with gun assembly)	20 FT +/-3 IN
A10560-25	25 FT +/-3 IN
A10560-35	35 FT +/-3 IN
A10560-50	50 FT +/-3 IN
A10560-75	75 FT +/-3 IN

RECOMMENDED SPARE PARTS		
Part #	Description	Qty.
Select Option Below Fluid Tip		
79140-01	Fluid Tip .042" Orifice (1.07mm)	1-2
79140-02	Fluid Tip .055" Orifice (1.40mm)	1-2
79140-03	Fluid Tip .070" Orifice (1.78mm)	1-2
79140-04	Fluid Tip .027" Orifice (0.71mm)	1-2
79140-05	Fluid Tip .047" Orifice (1.20mm)	1-2
80201-44	Fluid Tip .055" Orifice (1.40mm) Trans-Tech	1-2
80201-48	Fluid Tip .047" Orifice (1.20mm) Trans-Tech	1-2
Select Option Below Gun Head Complete		
79138-01	Spray Gun Head- Conventional/ Non-Bleed	0-1
79138-04	Spray Gun Head- Conventional Bleed	0-1
79138-07	Spray Gun Head- Trans-Tech/ Non-Bleed	0-1
79138-08	Spray Gun Head- Trans-Tech Bleed	0-1
Select Option Below Air Cap		
79153-65R-1	Air Cap	1-2
79196-98-1	Air Cap	1-2
79197-63-1	Air Cap	1-2
80194-00	Air Cap (Trans-Tech)	1-2
Select Option Below Bushing		
79143-00	Bushing, Air Valve (non bleed type)	0-1
79143-01	Bushing, Air Valve (bleed type)	0-1
Select Option Below Fluid Nozzle		
EMF-195	Fluid Nozzle (8 hole High Flow)	0-1
80198-00	Fluid Nozzle (Trans-Tech)	0-1
Select Option Below Electrode		
70430-01	Electrode (High Wear)	1-2
A11218-00	Electrode (non-electrostatic)	1-2
A10824-00	Red Locking Clip	1-2
EMF-203-05	Front Ferrule, 3/8" OD Tubing	0-2
EMF-202-05	Back Ferrule, 3/8" OD Tubing	0-2
77762-04	Collet, 8mm	0-1
77516-04	Collet, 6mm	0-1
77762-02	Collet, 10mm	0-1
80356-00	Block, Locking	2
A12524	Nut, Fitting (3/8 tube)	0-1
A12523	Fitting (3.8 tube to AN)	1-2
79171-00	Spring, Connector	2
79144-00	Shaft, Valve Piston	0-1

(Continued On Next Page)

RECOMMENDED SPARE PARTS (Cont.)		
Part #	Description	Qty.
79141-00	Connector Plug	0-1
EMF-192	Locater, Air Cap	0-1
79154-00	Retaining Ring, Tapered	1
79149-00	Screw, Retaining	2-4
79174-00	Screw, Nylon	2-4
79142-00	Screw	1
A12511-00	Screw, modified	1-2
SSF-3130	Screw	0-2
76566-24C	Screw	1-3
A10612-00	Square Cut Ring	2-4
13076-13	O-ring, PTFE	1
79001-01	O-ring, Solvent Proof	1-2
79001-04	O-ring, Solvent Proof	1-2
79001-05	O-ring, Solvent Proof	1-2
79001-06	O-ring, Solvent Proof	1-2
79001-28	O-ring, Solvent Proof	1-2
79001-29	O-ring, Solvent Proof	1-2
79001-30	O-ring, Solvent Proof	1-2
79001-31	O-Ring, Solvent Proof	2
79146-00	Seal, Rear Piston	0-1
7723-06	Piston, U Cup	0-1
EMF-7	Seal, Washer	1
78949-00	Microvalve (for dump valve version)	1

REPAIR KITS						
Part #	Description	Number of Applicators				Notes
		1-2	3-4	5-6	7-8	
A10410	Spray Head Mounting Sea O-Ring Kit	1	2	3	4	Includes: 1 ea. - 79001-04 O-Ring (Solvent Proof) 2 ea. - 79001-06 O-Ring (Solvent Proof) 1 ea. - 79001-05 O-Ring (Solvent Proof)
A10411	Spray Head Repair Kit	1	2	3	4	Includes: 1 ea. - 79151-00 Needle Shaft 1 ea. - 7723-06 Piston, U-Cup 1 ea. - 79001-28 O-Ring (Solvent Proof) 1 ea. - 79001-29 O-Ring (Solvent Proof) 3 ea. - 79001-01 O-Ring (Solvent Proof) 1 ea. - 13076-13 O-Ring PTFE 1 ea. - 79001-06 O-Ring (Solvent Proof) 1 ea. - RME-38 Spring 1 ea. - RME-32 Seal 1 ea. - 79001-01 O-Ring (Solvent Proof) 1 ea. - 79001-04 O-Ring (Solvent Proof) 2 ea. - 79001-06 O-Ring (Solvent Proof) 1 ea. - 79001-05 O-Ring (Solvent Proof) 2 ea. - 14061-09 Conductive Foam 1 ea. - 79171-00 Contact Spring

LUBRICANTS AND SEALERS	
Part #	Description
A11545-00	Petroleum Jelly Lubricant for all O-Rings
7969-03	Thread Sealant (Blue), Adhesive 24077
7969-10	Thread Sealant (White), Adhesive 59231, PTFE Paste
7969-05	Thread Sealant (Purple), Adhesive 22221
LSCH0009-00	Dielectric Grease (.88oz tube)

A 9060 or Voltage Master Control Unit

(See current 9060 or Voltage Master service manual supplied with the control unit for service information).

80202 TRANS-TECH KIT		
Part No.	Description	Qty.
80194	EV-40 AIR CAP	1
80198	NOZZLE, FLUID, MARKED WITH TT ON ONE FLAT	1
80199	RING, RETAINING	1
"A"	TIP, FLUID	1

80202 TRANS-TECH KIT		
Assembly No.	Description	"A"
80202-44	1.4MM (.055") DIA. TIP	80201-44
80202-48	1.2MM (.047") DIA. TIP	80201-48

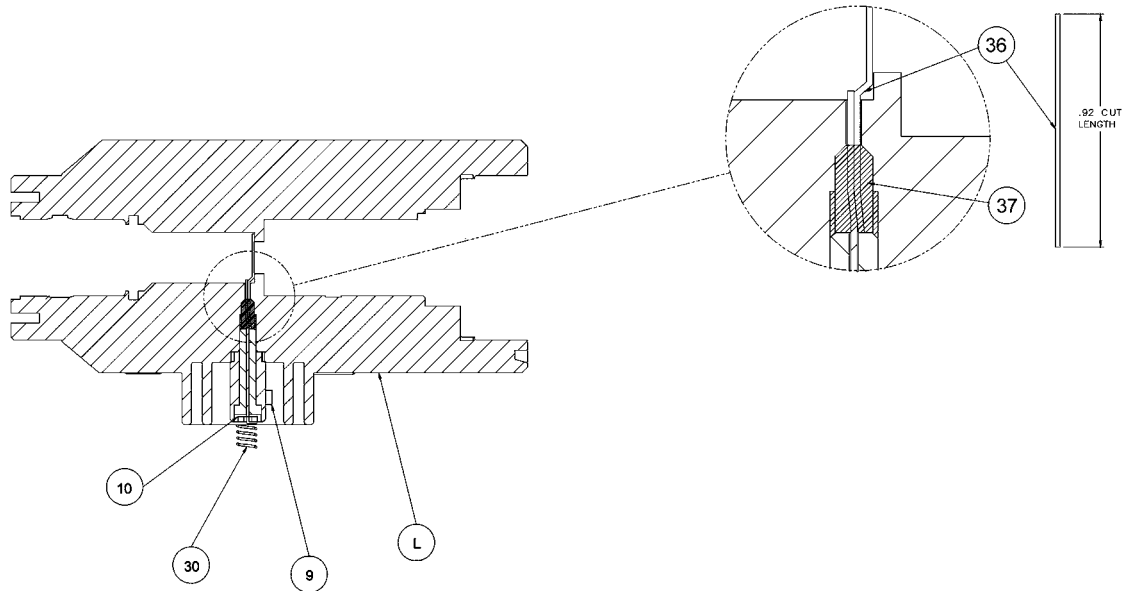

Figure 36: 80374 Evolver Bare Spray Head Assembly

80403 EVOLVER BARE SPRAY HEAD ASSEMBLY			
Item #	Part #	Description	Qty
9	80404-00	CONNECTION PLUG	1
10	79142-00	SCREW, SHCS 8-32 X .75 LG. FIBER GLASS	1
30	79171-00	SPRING CONNECTOR	1
36	SSW-1125	WIRE	1
37	14061-09	PLUG, CONDUCTIVE COMPRESSIBLE CONTACT	2
L	80402-00	HEAD, MACHINED ROBOT GUN (BLACK)	1

75777-XX SPRAY APPLICATOR COVERS	
Part #	Description
75777-01	Single Head Spray Applicator
75777-02	Dual Head Spray Applicator
75777-03	Robot Wrist Flange

74035-XX TEST AIR CAPS AND GAUGE ASSEMBLY	
Part #	Description
74035-21	#65R-1 Test Cap
74035-22	#98-1 Test Cap
74035-23	#63-1 Test Cap
74035-30	#EV-40 Test Cap

The 74035, Test Air Cap and Gauge Assembly, is designed for use with a Test Station or while the applicator is connected to the robot or reciprocator. The test air cap is comprised of two air pressure gauges, pressure gauge stand, special 74061-XX air caps, and all required tubing and fittings.

The air cap has two tapped holes for small barbed tube fittings. The fittings are located so that the gauges connected to them will measure the actual cap pressure of the atomization and pattern air.

Using this test cap will assure uniform atomization and pattern quality, regardless of air supply tube lengths from one applicator to another.

73896-01 Electrode and Air Cap Protector

This is a plastic cylinder that fits over the air cap retainer. The protector keeps the electrode and other spray head parts from being damaged during booth cleaning and at other times when the spray applicator is not in use.

TROUBLESHOOTING GUIDE

General Problem	Possible Cause	Solution
Fluid Does Not Turn On	Insufficient trigger pilot air.	Increase to 70 psi 5 bar minimum.
	Trigger air tube possibly left disconnected.	Reconnect tubing
	Trigger air tube is pinched or broken	Check tubing for kinks or damage.
	Piston seal within applicator spray head is not in place or there is an extremely tight fit between the seal and the cylinder wall.	Make sure that the seal is in the proper position and / or lubricate with a small amount of petroleum jelly.
	Piston u-cup is bad.	Replace if damaged (trigger air will leak out of rear cap).
No fluid flow	Clogged fluid nozzle.	Remove, inspect and clean fluid nozzle.
	Plugged fluid inlet.	Flush clean.
	No trigger pilot air.	Check trigger air pilot (70 psi 5 bar min.)
Continuous fluid flow	Trigger pilot air is not shutting off.	Remove trigger pilot air.
	Weak or damaged needle spring.	Replace needle spring.
	Fluid seal is worn or damaged.	Replace fluid seal.
Lack of fan air control	Improperly torqued seal retainer.	Torque to 30-35 lbs.-in.
	PTFE o-ring on bushing is damaged.	Replace PTFE o-ring (this shuts off the fan air).
	O-ring on bushing is damaged.	Replace o-ring (keeps fan and atomization air separated).
Low or no high voltage	High current draw.	Paint resistivity must be > 0.1 M Ohms.
	Loss of high voltage connection between power supply and manifold.	Check HV cable connection to manifold. Apply dielectric grease to cable end and reconnect.
	Contact spring damaged.	Replace contact spring.
	Conductive sponge damaged / removed.	Replace conductive sponge.
	Applicator grounding out.	Clean atomizer externally with non-polar solvent., check for internal fluid leaks or internal arcing.
	Power supply is damaged (refer to specific power supply manual for troubleshooting).	

WARRANTY POLICIES

LIMITED WARRANTY

Ransburg will replace or repair without charge any part and/or equipment that falls within the specified time (see below) because of faulty workmanship or material, provided that the equipment has been used and maintained in accordance with Ransburg's written safety and operating instructions, and has been used under normal operating conditions. Normal wear items are excluded.

THE USE OF OTHER THAN RANSBURG APPROVED PARTS, VOID ALL WARRANTIES.

SPARE PARTS:

One hundred and eighty (180) days from date of purchase, except for rebuilt parts (any part number ending in "R") for which the warranty period is ninety (90) days.

EQUIPMENT:

When purchased as a complete unit, (i.e., guns, power supplies, control units, etc.), is one (1) year from date of purchase. **WRAPPING THE APPLICATOR IN PLASTIC, SHRINK-WRAP, ETC., WILL VOID THIS WARRANTY.**

RANSBURG'S ONLY OBLIGATION UNDER THIS WARRANTY IS TO REPLACE PARTS THAT HAVE FAILED BECAUSE OF FAULTY WORKMANSHIP OR MATERIALS. THERE ARE NO IMPLIED WARRANTIES NOR WARRANTIES OF EITHER MERCHANT ABILITY OR FITNESS FOR A PARTICULAR PURPOSE. RANSBURG ASSUMES NO LIABILITY FOR INJURY, DAMAGE TO PROPERTY OR FOR CONSEQUENTIAL DAMAGES FOR LOSS OF GOODWILL OR PRODUCTION OR INCOME, WHICH RESULT FROM USE OR MISUSE OF THE EQUIPMENT BY PURCHASER OR OTHERS.

EXCLUSIONS:

If, in Ransburg's opinion the warranty item in question, or other items damaged by this part was improperly installed, operated or maintained, Ransburg will assume no responsibility for repair or replacement of the item or items. The purchaser, therefore will assume all responsibility for any cost of repair or replacement and service related costs if applicable.

Manufacturing

1910 North Wayne Street
Angola, Indiana 46703-9100
Telephone: 260-665-8800
Fax: 260-665-8516

Technical Service — Assistance

320 Phillips Ave.
Toledo, Ohio 43612-1493
Telephone (toll free): 800-233-3366
Fax: 419-470-2233

Technical Support Representative will direct you to the appropriate telephone number for ordering Spare Parts.

Form No. AA-15-01
Litho in U.S.A.
12/16

© 2016 Carlisle Fluid Technologies, dba Finishing Brands
All rights reserved. Models and specifications subject to change without notice.

