



For additional information or copies of your service manual, please visit us online at:

[binks.com/en/library](https://binks.com/en/library)

Or use this QR code with your mobile device:

## **DR-1 FLUID REGULATOR**



Obey local or municipal regulations for product recycling and disposal.

## 02 CONTENTS

<b>03 SAFETY</b>	<b>3-10</b>
03.1 SAFETY PRECAUTIONS AND HAZARDS.....	3
03.2 ADDITIONAL SAFETY INFORMATION .....	10
<b>04 INTRODUCTION</b>	<b>11-12</b>
FEATURES.....	11
SPECIFICATIONS .....	11
DR-1 FLOW VS SIGNAL PRESSURE .....	12
<b>05 OPERATION</b>	<b>13</b>
OPERATION .....	13
<b>06 MAINTENANCE</b>	<b>15-18</b>
TOOLS REQUIRED.....	15
PRELIMINARY PROCEDURES .....	15
DISASSEMBLY PROCEDURES .....	15
REGULATOR CORSS-SECTIONAL VIEW.....	16
ASSEMBLY PROCEDURES.....	17
TEST PROCEDURES .....	18
PREVENTATIVE MAINTENANCE.....	18
<b>07 TROUBLESHOOTING</b>	<b>19-20</b>
TROUBLESHOOTING GUIDE .....	19
<b>08 PARTS IDENTIFICATION</b>	<b>21-23</b>
REGULATOR CROSS-SECTIONAL VIEW.....	21
DR-1 FLUID REGULATOR PARTS LIST .....	22
RECOMMENDED SPARE PARTS LIST .....	23
SERVICE KITS .....	23
<b>09 MANUAL REVISIONS</b>	<b>25</b>
<b>10 WARRANTY POLICY</b>	<b>27</b>

This page intentionally left blank.

## 03 SAFETY

### 03.1 SAFETY PRECAUTIONS

Before the operation, maintenance, or servicing of this Binks system; fully read and understand all technical and safety literature for your product. This manual contains information that is important for you to know and understand.

#### **This information relates to USER SAFETY and the PREVENTION OF EQUIPMENT PROBLEMS.**

To help you understand this information, we use recognizable ANSI Z535 and ISO warning boxes and symbols throughout this manual. Please obey these safety sections.

#### **⚠ DANGER**

**DANGER!** Indicates a hazardous situation that, if not avoided, will result in death or severe injury.

#### **⚠ WARNING**

**WARNING!** Indicates a hazardous situation that, if not avoided, could result in death or severe injury.

#### **⚠ CAUTION**

**Caution!** Indicates a hazardous situation that, if not avoided, could result in minor or moderate injury, or equipment damage.

#### **NOTICE**

**Notice:** Indicates information considered important but not hazard related.

#### **SAFETY**

**Safety:** Indicates a type of safety instruction, or a separate panel on a safety placard, where specific safety-related instructions or procedures are described.

Careful study and continued use of this manual will provide a better understanding of the equipment functions and procedures.

This understanding will result in improved operation, efficiency, and longer, trouble-free service with faster and easier troubleshooting. If you need the necessary safety literature for your specific system, contact your local Binks representative or Binks directly.

#### **NOTICE**

This manual lists standard specifications and service procedures. Differences can occur between this literature and your equipment.

Differences in local or municipal codes, manufacturer or plant requirements, material delivery requirements, and more can make variations unpreventable. To find these differences, compare this manual to your system installation drawings and other applicable Binks equipment manuals.

#### **⚠ WARNING**

The user **MUST** read and be familiar with the Safety Section in this manual and the safety literature therein identified.

Only trained personnel can operate this equipment.



All personnel who operate, clean, or maintain this equipment **MUST** fully read and understand this manual! To operate and service the equipment, follow all **WARNINGS** and safety requirements.



The user must be aware of and adhere to **ALL** local building and fire codes and ordinances, as well as **NFPA 33 AND EN 16985 SAFETY STANDARDS, LATEST EDITION**, or applicable country safety standards, before the installation, operation, or servicing of this equipment.





#### **⚠ WARNING**

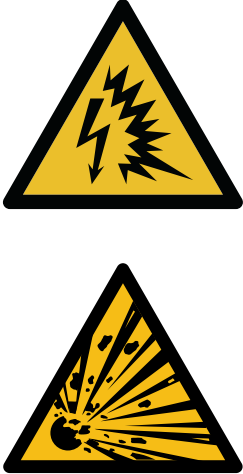

The hazards shown on the pages that follow can occur during the normal use of this Binks equipment, but not all listed hazards will be applicable to your product model or equipment.





**Repairs may only be performed by personnel authorized by Binks.**

<p><b>AREAS</b> Indicate possible hazard occurrences.</p>	<p><b>HAZARDS</b> Indicate possible hazards.</p>	<p><b>SAFEGUARDS</b> Prevention of possible hazards.</p>
<p><b>Spray Areas</b></p>  	<p><b>Fire Hazards</b></p> <p>Improper or unsatisfactory operation and maintenance procedures will cause a fire hazard.</p> <p>If the safety interlocks are disabled during operation, protection against accidental arcing is shut off and can cause a fire or explosion.</p> <p>Frequent Power Supply or Controller shutdown identifies a problem in the system. For this occurrence, a correction will be necessary</p>	<p>Fire extinguishing equipment must be present in the spray area. Periodically run a test to make sure the equipment stays usable.</p> <p>Keep spray areas clean to prevent the build-up of combustible residues.</p> <p>Do not smoke in the spray area.</p> <p>The high voltage supplied to the atomizer must be turned off before the equipment is cleaned, flushed or maintained.</p> <p>Spray booth ventilation must be kept at the rates as set by NFPA-33, OSHA, country, local, and municipal codes.</p> <p>If flammable or combustible solvents are used to clean the equipment, ventilate the area.</p> <p>Prevent electrostatic arcing. Maintain spark-safe work distance between the parts that get coated and the applicator. A span of one inch for every 10KV of the output voltage is necessary.</p> <p>Do an equipment test only in areas free of combustible material. The test may necessitate the high voltage to be on, but only as instructed.</p> <p>Non-factory replacement parts or unauthorized equipment modifications can cause a fire or injury.</p> <p>The key switch bypass is used only during setup operation.</p> <p>Do no production work with disabled safety interlocks.</p> <p>Set up and operate the paint procedure and equipment under NFPA-33, NEC, OSHA, local, municipal, country, and European Health and Safety Norms.</p>

<p><b>AREAS</b> Indicate possible hazard occurrences.</p>	<p><b>HAZARDS</b> Indicate possible hazards.</p>	<p><b>SAFEGUARDS</b> Prevention of possible hazards.</p>
<p><b>Spray Areas</b></p> 	<p><b>Explosion Hazard</b></p> <p>Improper or unsatisfactory operation and maintenance procedures will cause a fire or explosion hazard.</p> <p>If the safety interlocks are disabled during operation, protection against accidental arcing is shut off and can cause a fire or explosion.</p> <p>Frequent Power Supply or Controller shutdown identifies a problem in the system. For this occurrence, a correction will be necessary.</p>	<p>Prevent electrostatic arcing. Maintain spark-safe work distance between the parts that get coated and the applicator. A span of one inch for every 10KV of output voltage is necessary.</p> <p>Unless specifically approved for use in hazardous locations, put all electrical equipment outside of Class I or II, Division 1 or 2 hazardous areas in accordance with NFPA-33, or outside of Zone 2 or Zone 22 in accordance with EN standards.</p> <p>If equipped, set the current overload sensitivity as described in the related section of the equipment manual. If incorrectly set, the current overload sensitivity for protection against accidental arcing is turned off and can cause a fire or explosion.</p> <p>Frequent power supply shutdown indicates a problem in the system, which requires correction.</p> <p>Always turn off the control panel power before the system is flushed, cleaned, or servicing the spray system equipment. Make sure no objects are within the spark-safe work distance before the high voltage is turned on.</p> <p>The control panel must interlock with the ventilation system and conveyor in accordance with NFPA-33, EN 50176.</p> <p>Fire extinguishing equipment must be present in the spray area. Periodically run a test to make sure the equipment stays usable. Do an equipment test only in areas free of combustible material.</p>
<p><b>General Use and Maintenance</b></p> 	<p>Improper or unsatisfactory operation and maintenance procedures will cause a fire hazard.</p> <p>Personnel must be correctly trained in the operation and maintenance of this equipment.</p>	<p>Train all personnel in accordance with the requirements of NFPA-33, EN 60079-0.</p> <p>Before equipment operation, personnel must read and understand these instructions and safety precautions.</p> <p>Obey appropriate local, municipal, state, and national codes governing ventilation, fire protection, operation maintenance, and housekeeping.</p> <p>Reference OSHA, NFPA-33, EN Norms, and your insurance company requirements.</p>

<p><b>AREAS</b> Indicate possible hazard occurrences.</p>	<p><b>HAZARDS</b> Indicate possible hazards.</p>	<p><b>SAFEGUARDS</b> Prevention of possible hazards.</p>
<p><b>Spray Area High Voltage Equipment</b></p>    	<p><b>Electrical Discharge</b></p> <p>This equipment contains a high-voltage device that can cause an electrostatic induction on ungrounded objects. This electrical charge is capable of igniting coating materials.</p> <p>Insufficient ground will cause a spark hazard. A spark can ignite many coating materials and cause a fire or explosion.</p>	<p>Operators in the spray area and the parts to be sprayed must be sufficiently grounded.</p> <p>All conductive objects inside the spray area must be grounded.</p> <p>Hold the parts that get sprayed on conveyors or hangers that are correctly grounded. The resistance between the parts and the earth-ground must not be more than 1 MΩ. Refer to: NFPA-33.</p> <p>Before the equipment is operated, ground all operators. They cannot wear rubber-soled insulated shoes. Wear ground straps on wrists or legs for sufficient ground contact.</p> <p>Operators must not wear or carry ungrounded metal objects.</p> <p>When used, operators must make complete contact with the applicator handle and electrostatic gun. Use conductive gloves or gloves with the palm section cut out.</p> <p>Operators must wear grounded footwear.</p> <p><b>NOTE: REFER TO NFPA-33 OR SPECIFIC COUNTRY SAFETY CODES FOR GUIDANCE TO CORRECTLY GROUND THE OPERATOR.</b></p> <p>Except for objects needed for the high-voltage process, all electrically conductive objects in the spray area are to be grounded. Supply a grounded conductive floor in the spray area.</p> <p>Always turn off the applicator voltage before the system is flushed, cleaned, or when servicing the spray system equipment.</p> <p>Unless specifically approved for use in hazardous locations, put all electrical equipment outside of Class I or II, Division 1 or 2 hazardous areas in accordance with NFPA-33, or outside of Zone 2 or Zone 22 in accordance with EN standards.</p> <p>Do not install an applicator into a fluid system if the solvent supply is ungrounded.</p> <p>Do not touch an energized applicator electrode.</p>

<p><b>AREAS</b> Indicate possible hazard occurrences.</p>	<p><b>HAZARDS</b> Indicate possible hazards.</p>	<p><b>SAFEGUARDS</b> Prevention of possible hazards.</p>
<p><b>Spray Areas</b></p> 	<p><b>Toxic Fluid or Fumes</b></p> <p>Toxic fluids or fumes can cause severe injury or death if splashed in the eyes or on the skin, or if inhaled or swallowed.</p>	<p>Read the Safety Data Sheet (SDS) for instructions to know and understand how to handle the specific hazards of the fluids used, and the effects of long-term exposure.</p> <p>During the spray, clean, or servicing of equipment, or when in the work area, keep the work area fully ventilated.</p> <p>Always wear personal protective equipment (PPE) when in the work area or during equipment operation. Refer to the Personal Protective Equipment warnings in this manual.</p> <p>Store hazardous fluid in approved containers and refer to local, municipal, state, and national codes governing the disposal of hazardous fluids.</p>
<p><b>Spray Area and Equipment Use</b></p> 	<p>High-pressure fluid sprayed from the gun, hose fittings, or ruptured/damaged components can pierce the skin.</p> <p>While this injury can appear as cut skin, this is a severe injury that can result in the amputation of the affected area.</p>	<p>Do not point or operate the spray gun at the body part of a person.</p> <p>Do not put your hand or fingers over the gun fluid nozzle or fittings in the hose or Proportioner.</p> <p>Do not try to stop or deflect leaks with your hand, glove, body, or shop rag.</p> <p>Do not “blowback” fluid, as the equipment is not an air spray system.</p> <p>Relieve pressure in the supply hoses, Proportioner, and QuickHeat™ hose before the equipment is inspected, cleaned, or serviced.</p> <p>Use the lowest possible pressure to recirculate, purge, or troubleshoot the equipment.</p> <p>Examine the hoses, couplings, and fittings every day. Service or immediately replace parts that leak, are worn, or are damaged. Replace high-pressure hose sections. They cannot be recoupled or serviced.</p>

<p><b>AREAS</b> Indicate possible hazard occurrences.</p>	<p><b>HAZARDS</b> Indicate possible hazards.</p>	<p><b>SAFEGUARDS</b> Prevention of possible hazards.</p>
<p><b>Equipment and Fluids</b></p> 	<p><b>Skin and Clothing Burns</b></p> <p>Equipment surfaces and fluids can become very hot during operation.</p>	<p>Do not touch hot fluid or equipment during operation.</p> <p>Do not let clothing touch the equipment during operation or immediately after the equipment is stopped.</p> <p>Let the equipment fully cool before the examination or servicing of the component.</p>
<p><b>Pressurized Aluminum Parts</b></p>    	<p>The use of certain solvents and chemicals can cause equipment damage and severe personal injury.</p>	<p>Do not use 1,1,1-trichloroethane, methylene chloride or other halogenated hydrocarbon solvents or fluids that contain such solvents.</p> <p>These solvents can cause a severe chemical reaction and equipment rupture that results in equipment and property damage, serious bodily injury, or death.</p>

<p><b>AREAS</b> Indicate possible hazard occurrences.</p>	<p><b>HAZARDS</b> Indicate possible hazards.</p>	<p><b>SAFEGUARDS</b> Prevention of possible hazards.</p>
<p><b>Spray Areas</b></p> 	<p><b>Do Not Touch</b></p> <p>The effect of paint flow rates and formulations on the quality of atomization can cause the turbines to rotate at high speeds.</p>	<p>Do not use a rag or gloved hand against the bell edge to stop or slow down a bell during rotation.</p> <p>Do not try to clean the bell edge during rotation.</p>

**⚠ CAUTION**

Only operate the equipment after you have read this section.

**03.2 ADDITIONAL SAFETY INFORMATION**

Observe all local or municipal safety measures and wear approved protective equipment when servicing this equipment. Clean all spilled chemicals and materials and do all work in a clean and organized environment to prevent personal injury and equipment damage.

**⚠ DANGER**

To prevent injury or electrocution while the system is under power, do not contact, disconnect, or manipulate electrical connections or devices. The main disconnect on the right side of the controller can be locked out. Follow the proper Lockout–Tagout (LOTO) procedures for internal controller electrical work.

Only qualified electrical personnel can perform the work if diagnosis and troubleshooting are not possible during working conditions.

**⚠ WARNING**

To prevent possible chemical spillage when personnel are not on site, air and fluid supplies for the equipment must be disabled when the equipment idles for an extended period, such as an end-of-day shutdown.

**NOTICE**

During the initial commission of the equipment and at periodic times throughout equipment life, visually examine all fluid fittings for leaks.

Periodically, it is necessary to visually examine all pieces of this equipment for signs of noticeable degradation due to chemicals or other conditions in the equipment's environment.

**SAFETY**

Obey local or municipal regulations that require installed fire suppression for equipment operation.

If the operation of this equipment, sensors, switches, or other ancillary equipment occurs in the presence of flammable gases and vapors, connect this equipment through intrinsic-safe or Zener barriers. Classify them as a 'simple apparatus' or approve them for use in these areas.

## FEATURES: MODEL 74151

- Two independently controlled flow pressure ranges.
- High flow range port for higher fluid deliveries.
- Low flow range for more precise control over lower fluid deliveries.
- Interchangeable low flow ratios (1:1, 1:2, 1:3, 1:4, 1:6, 1:8, 1:10) for precise control.
- Stainless steel and coated wetted parts for decreased color change time.

Specifications - 74151	
Environmental / Physical	Description
Height	1-7/8-Inch (48mm)
Height W/Fittings	2-1/8-Inch (54mm)
Diameter	2-3/4-Inch (70mm)
Diameter W/Fittings	3-3/8-Inch (86mm)
Mechanical	Description
Air Pressure	Variable by Control (Manual or Automatic) 100 PSI (7 bar max.)
Fluid Input	300 PSIG (20.7 bar max.) (10 PSI minimum above output pressure)
Fluid Output	Variable by ratio.
Pneumatic / Fluid Connections	Description
Air Pilot	#10-32 Thread (Low & High)
Fluid In	1/4-Inch NPSM Thread
Fluid Out	1/8-Inch NPSM 3/16 IN OD Tubing, use (70589-04) 1/4-Inch OD Tubing, use (70589-05) 3/8-Inch OD Tubing, use (70589-10) 6mm OD Tubing, use (70589-06) 8mm OD Tubing, use (70589-11) 3/8-Inch NPSM Hose Connection, use (70589-12)
Volume of Paint Held Within Regulator	5cc

### DR-1 FLOW VS SIGNAL PRESSURE

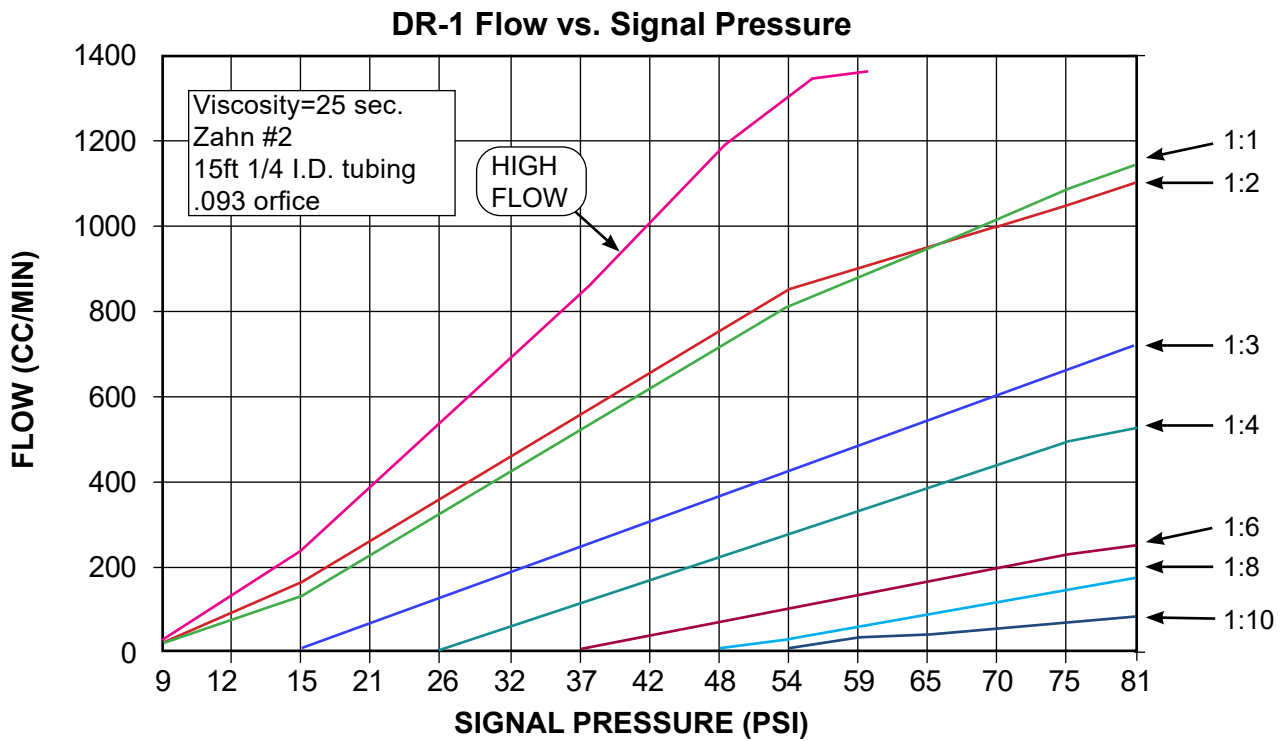
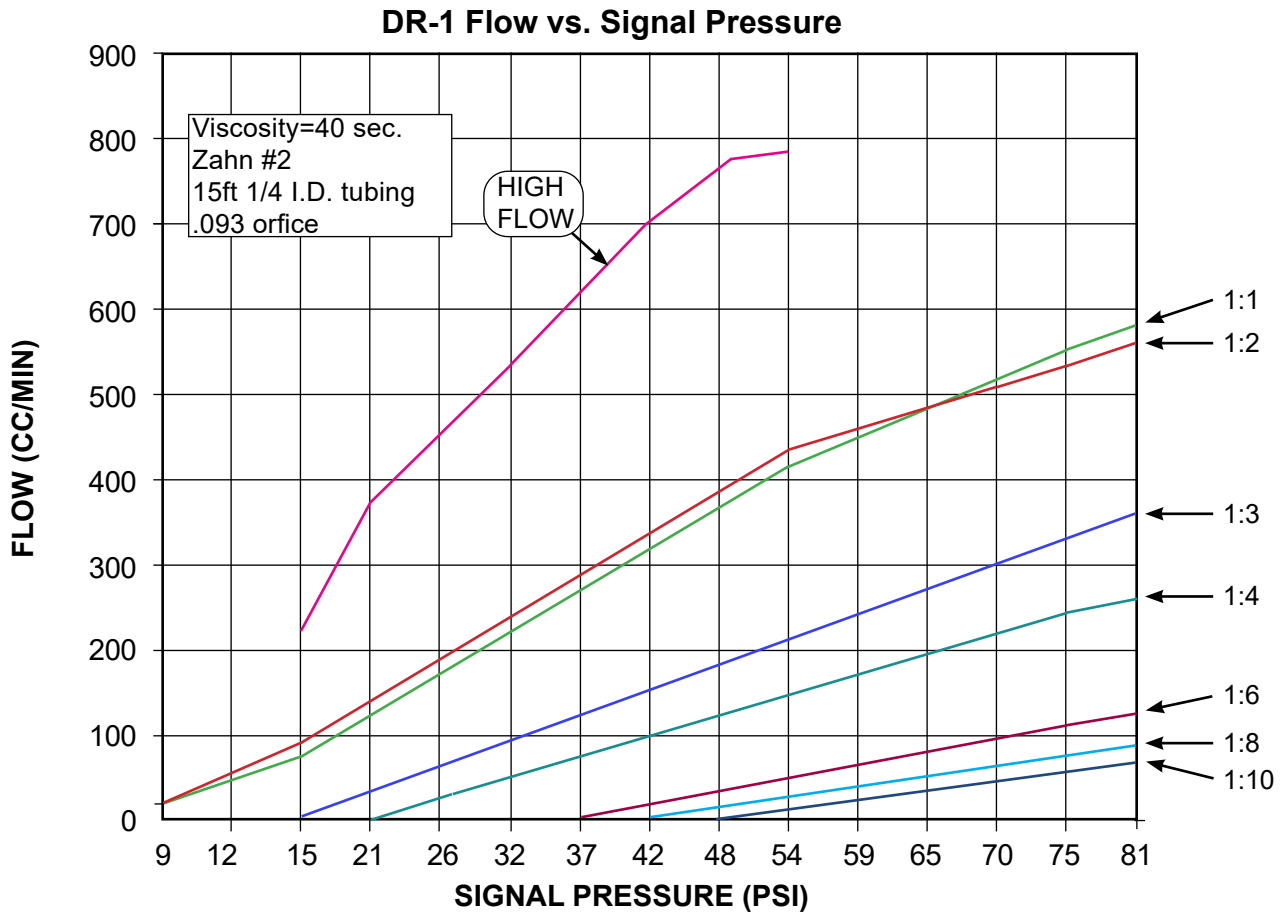

## OPERATION

The DR-1 Regulator is designed to provide remote control fluid regulation for automatic coating applications.

The regulator features two independently controllable flow pressure ranges from the fluid output port. The high flow range port accommodates higher fluid deliveries and minimal color change times. The lower flow ranges provide precise fluid delivery control. There are seven lower range models available (1:1, 1:2, 1:3, 1:4, 1:6, 1:8, and 1:10) which can be selected based on the required fluid flow rate.

Separate pilot signals modulate each of the regulator's two diaphragms to control the amount of paint being delivered from the regulator to the spray applicator.

Because of the regulator's dual range capabilities, it provides the user flexibility for selecting either the high flow range or the low flow range. Different coating material viscosities and quick color change requirements may necessitate the use of both ranges. If color change time is not a factor or if material viscosity remains relatively constant, either port may be used depending on flow rate requirements. All regulators, regardless of ratio designation, have the high flow port.

The low flow (i.e. 1:2, 1:4, etc.) port provides a lower, more precise flow response curve. Fluid output, as a result, is less likely to be affected by pilot signal errors. An increase in the ratio (i.e. from 1:2 to 1:4) provides a lower slope in the flow/air signal pressure curve, but a more precise response curve. This same increase in ratio however, will reduce flow capacity and should be considered when selecting the proper regulator ratio.

The following factors must then be considered when selecting the regulator ratio required for proper fluid control:

- Fluid tubing inside diameter (ID) and length
- Fluid feed tube inside diameter (ID) and length
- Fluid viscosity
- Fluid input pressures

Preliminary testing will determine which regulator ratio should be used. If conditions change after installation which require a different low flow ratio, this regulator can be easily altered by replacing the existing ratio spacer ring and upper retainer with the desired ratio (ratio designation is etched on the side of the spacer ring).

### WARNING

**NEVER** wrap the applicator, associated valves and tubing, and supporting hardware in plastic to keep it clean. A surface charge may build up on the plastic surface and discharge to the nearest grounded object. Efficiency of the applicator will also be reduced and damage or failure of the applicator components may occur. **WRAPPING THESE COMPONENTS IN PLASTIC WILL VOID WARRANTY.**

This page intentionally left blank.

## MAINTENANCE

### TOOLS REQUIRED

- 3/8", 7/16", 7/8", and 15/16" Open-End Wrenches
- 5/32" Allen Head Wrench
- Adjustable Wrench
- Screwdriver
- Repair Kit, 73913-00 or 73913-01

### PRELIMINARY PROCEDURES

Prior to removing the regulator for service or repair, perform the following:

1. If possible, flush the regulator with suitable cleaning solvent.
2. Turn the fluid and air "OFF" to the regulator and disconnect the air and fluid lines from the regulator.
3. Remove the regulator for service.

### DISASSEMBLY PROCEDURES (Refer to Figure 1)

#### NOTICE

Unless replacing Item 1 (cap) and/or Item 2 (spacer ring), it is **NOT** necessary to remove Item 18 (air fitting) and Item 15 (gasket).

Item 11 (regulating needle and seat) is a matching set with matching serial numbers. Care must be taken to not use needles and seats with non-matching serial numbers as fluid leakage may occur. If either component needs to be replaced, a new matched set must be used.

1. Remove Item 4 (8 screws) holding the regulator assembly together with the 5/32" Allen wrench.
2. Remove Item 1 (cap), Item 9 (upper diaphragm), Item 2 (spacer ring), and Item 3 (lower housing assembly). This will leave the diaphragm assembly Item 5 (upper diaphragm retainer), Item 14 (center diaphragm), Item 7 (center diaphragm retainer), Item 17 (bleed spacer), Item 8 (lower diaphragm), Item 10 (o-ring), and Item 6 (lower diaphragm retainer) held together by Item 16 (screw).

#### ⚠ CAUTION

When separating parts it may be necessary to use a small screwdriver. Care should be taken to **NOT** damage the components. Damage of these parts may cause leakage.

3. With a screwdriver, remove Item 16 (screw) from the diaphragm assembly.
4. Separate Item 6 (lower diaphragm retainer), Item 10 (o-ring), Item 8 (lower diaphragm), Item 17 (bleed spacer), Item 14 (center diaphragm), and Item 5 (upper diaphragm retainer).
5. With the 7/8" and the 15/16" open-end wrenches, remove Item 13 (retaining plug), Item 12 (spring,) and Item 11 (regulating needle) from Item 3 (lower housing).
6. Remove Item 11 (regulating seat) and Item 10 (o-ring) from the lower housing assembly.
7. Clean all metal parts with suitable cleaning solvent. DO NOT use solvent on the diaphragms or o-rings.

#### ⚠ CAUTION

Care **MUST** be taken while cleaning the coated parts of the regulator to prevent scratching.

PARTS IDENTIFICATION

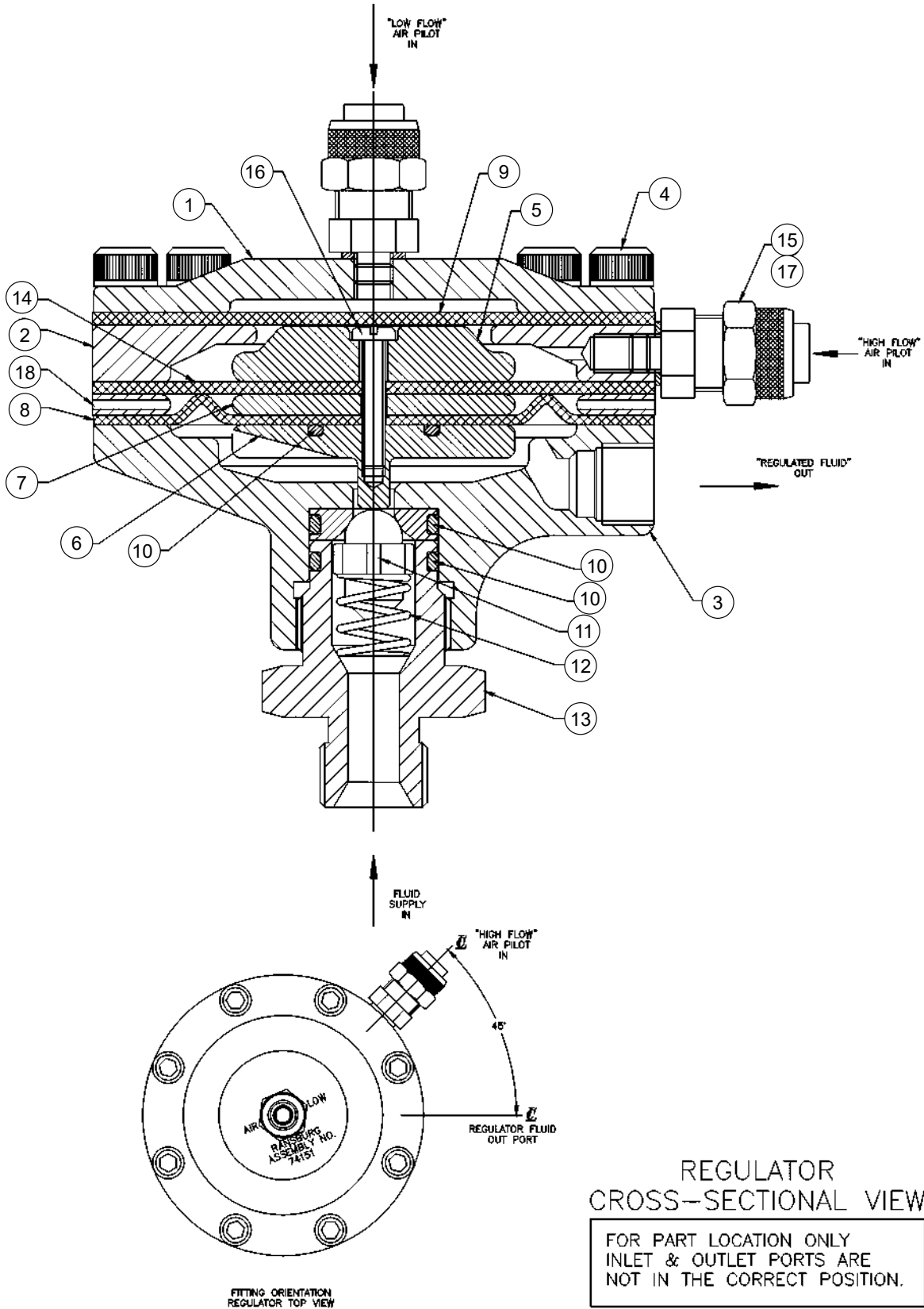

Figure 1: Regulator Cross-Sectional View

## ASSEMBLY PROCEDURES

(Refer to Figure 1)

1. Inspect Item 11 (regulating needle and seat) for damage. If either of these items are damaged or the mating surfaces are scratched, both items should be replaced as a matching set.
2. Discard the following items and replace them with the new item from the 73913-00 or 73913-01 repair kit:
  - Item 16: Screw
  - Item 10: O-Ring
  - Item 9: Upper Diaphragm
  - Item 14: Center Diaphragm
  - Item 8: Lower Diaphragm
3. Place Item 10 (o-ring) in the slot on Item 6 (lower diaphragm retainer).
4. Place Item 8 (lower diaphragm) on Item 6 (lower diaphragm retainer) with the side of the diaphragm contacting the retainers (o-ring side).
5. Stack the following parts on Item 8 (lower diaphragm), in the following order:
  - Item 7: (Center Diaphragm Retainer)
  - Item 18: (Bleed Spacer)
  - Item 14: (Center Diaphragm)
  - Item 5: (Upper Diaphragm Retainer)
  - Item 16: (Screw)
6. Ensure that clearance holes in Items 8 and 14 (diaphragms) and Item 17 (bleed spacer) are aligned properly and tighten Item 16 (screw). Use adhesive 222 on screw threads. Set the diaphragm assembly aside.
7. Place Item 3 (lower housing) on table with bottom threaded opening facing "UP".
8. Insert Item 10 (o-ring) onto Item 11 (regulating seat) and then insert the assembly into Item 3 (lower housing). The beveled side of the regulating seat must be "UP".

9. Place Item 11 (regulating needle) into Item 3 (lower housing) with the ball end against Item 11 (regulating seat).
10. Place Item 10 (o-ring) on Item 13 (retaining plug).

### NOTICE

Apply a small amount of non-silicone lubricant to Item 10 (o-ring) prior to assembly.

11. Place Item 12 (spring) into Item 3 (lower housing) over Item 11 (regulating needle) and thread Item 13

### ⚠ CAUTION

Verify regulator seat and needle have matching serial numbers.

(retaining plug) into Item 3 (lower housing). Tighten Item 13 (retaining plug) to 25-30 lbs•ft, ensuring that Item 11 (regulating needle) and Item 12 (spring) remain in the center of Item 3 (lower housing).

12. Place Item 3 (lower housing) on table with bowl facing "UP" and place diaphragm assembly (from step 4) into bowl of Item 3 (lower housing), with pin of Item 6 (lower diaphragm retainer) facing "DOWN". Rotate the diaphragm assembly so that the slot on Item 6 (lower retainer) is 180° to the outlet port of Item 3 (lower housing) for cleaner flushing of the regulator assembly.
13. Place Item 2 (spacer ring) on the top of Item 14 (center diaphragm) with largest opening facing "DOWN". Rotate Item 2 (spacer ring), without rotating the diaphragm assembly, so that the air pilot port of Item 2 (spacer ring) is 45° to the outlet port of Item 3 (lower housing) and all the clearance holes are aligned (see Figure 1).
14. Place Item 9 (upper diaphragm) on Item 2 (spacer ring) and align holes.
15. Place Item 1 (cap) on Item 9 (upper diaphragm). Align holes and insert Item 4 (8 screws).

### ⚠ CAUTION

DO NOT scratch the coating.

16. Tighten opposing screws alternately to 10 lbs•in, ensuring uniform sealing of the diaphragms. Then follow by tightening each screw in a circle pattern to 20 lbs•in.
17. If Item 15 (air fittings) were removed from either Item 2 (spacer ring) or Item 1 (cap), screw them along with Item 18 (gasket) back onto these items.

### **⚠ CAUTION**

**DO NOT** overtighten the air fittings. Overtightening the fittings may cause the stem of the fitting to snap off.

## **TEST PROCEDURES**

### **(Refer to Figure 1)**

After repair is complete, test the regulator in the following manner:

1. Set air and fluid regulators to zero and attach air and fluid lines to the regulator.
2. Gradually increase air pressure to the regulator to 80 psi, visually checking for leaks. Tighten Item 4 (screws) if leakage occurs.
3. Set air regulator to zero. Gradually increase fluid pressure to 80 psi, visually checking for leakage. Clean or replace Item 11 (needle and seat) if leakage at outlet port.

## **NOTICE**

If water or solvent is used for testing, it is normal for minor leakage to occur at the fluid output port, due to the low viscosities of these fluids.

4. Gradually increase air pressure on either of the air lines and visually observe a gradual increase in fluid flow. If regulator does not perform satisfactorily, inspect components for damage and replace where required.

## **PREVENTIVE MAINTENANCE**

1. Rebuild with 73913, Repair Kit, and 74160-00, needle and seat, at 6 months minimum, 12 months maximum.
2. Re-torque eight (8) screws at the following intervals:
  - 2 days after rebuild
  - Immediately before installation
  - 6 month intervals

## TROUBLESHOOTING GUIDE

General Problem	Possible Cause	Solution
<b>No Fluid Flow</b>	Plugged fluid inlet	Flush clean.
	Item 11 stuck (Regulating needle and Seat)	Remove and clean or replace.
	No pilot air	Check pilot air signal.
	Ruptured Item 9 (Upper Diaphragm)	Rebuild regulator,
	Ruptured item 14 (Center Diaphragm)	Rebuild regulator.
<b>Fluid Will Not Shut Off</b>	Dirt in Item 11 (Regulating Needle / Seat)	Remove and clean or replace. (Must be replaced as a set, see "Maintenance" section.)
	Pilot air not shut off	Check signal air supply.
	Borken Item 12 (Spring)	Replace Item 12. (Spring)
<b>Paint Leakage</b>	Item 4 loose (Screws)	Tighten per "Assembly Procedure" in the "Maintenance section.
	Ruptured Item 8 (Lower Diaphragm)	Rebuild regulator.
	Item 13 loose (Retaining Plug)	Tighten. torque to 25-30 lbsft (See "Maintenance" section).
	Loose fluid fitting	Tighten.
	Item 10 pinched (O-ring)	Replace Item 10 (O-ring).
<b>Air Leakage</b>	Loose air fitting	Tighten.
	Item 4 loose (Screws)	Tighten.
	Ruptured Item 9 (Upper Diaphragm)	Rebuild regulator.
	Ruptured item 14 (Center Diaphragm)	Rebuild regulator.
<b>Low Fluid Flow</b>	Incorrect regulator ratio	Refer to "Operations" section for correct sizing information.
	Fluid supply pressure too low	Increase fluid supply preesure. (Do not exceed 100 pisp) (See "Specifications" in the "Introduction" section).
	Air pilot too low	Check air pilot signal.

(Continued On Next Page)

## TROUBLESHOOTING GUIDE

General Problem	Possible Cause	Solution
<b>Inconsistent Fluid Flow</b>	Item 8 stretched from excessive air pilot signal (Lower Diaphragm)	Rebuild regulator.
	Ruptured Item 9 (Upper Diaphragm)	Rebuild regulator.
	Ruptured Item 14 (Center Diaphragm)	Rebuild regulator.
	Inconsistent air pilot	Check pilot air supply.
	Inconsistent fluid supply pressure	Check fluid supply.
<b>High Fluid Flow</b>	Incorrect regulator ratio	Refer to "Operations" section for correct sizing information.
	Fluid supply pressure too high	Lower fluid supply pressure.

PARTS IDENTIFICATION

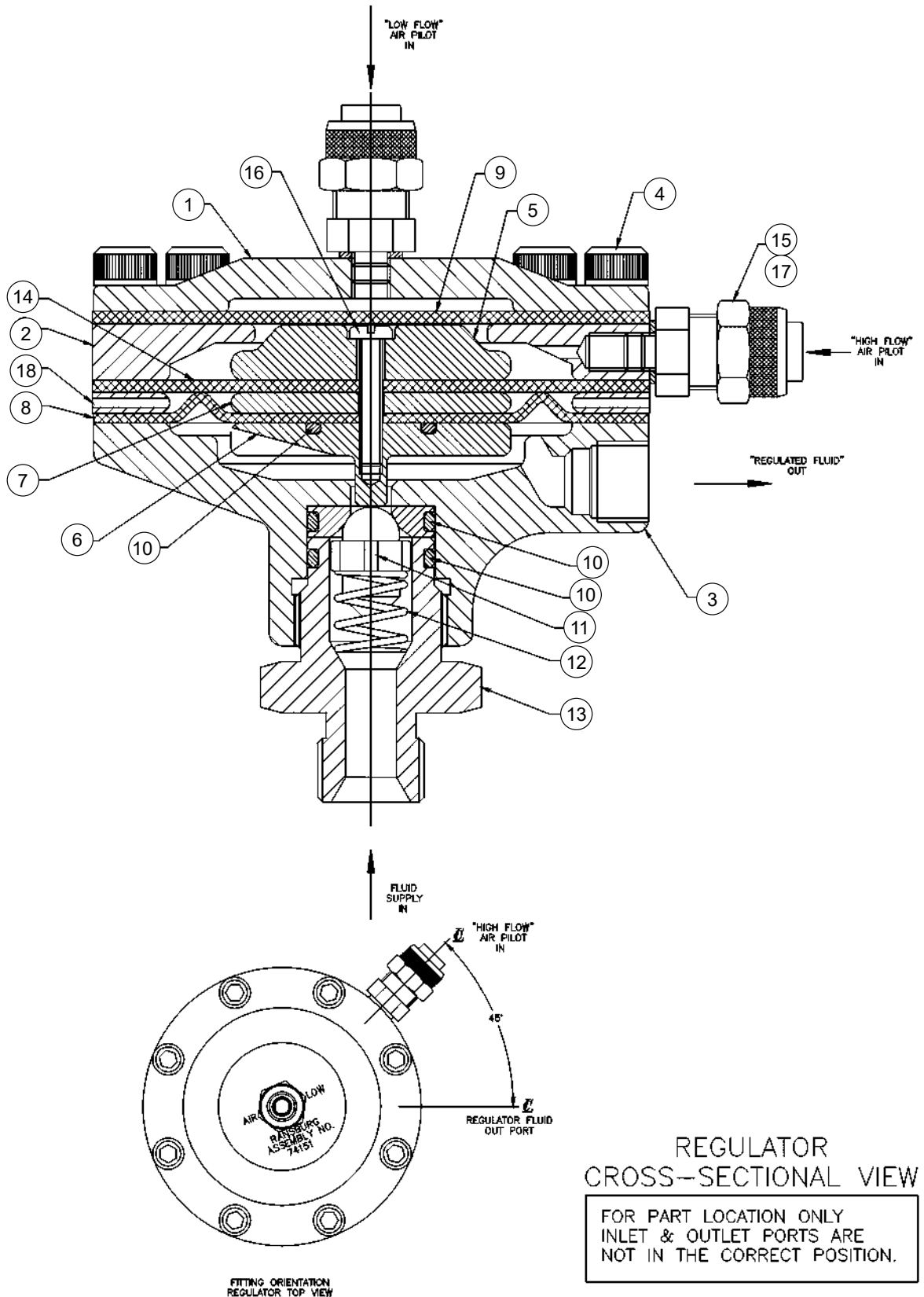

REGULATOR  
CROSS-SECTIONAL VIEW

FOR PART LOCATION ONLY  
INLET & OUTLET PORTS ARE  
NOT IN THE CORRECT POSITION.

Figure 2: Regulator Cross-Sectional View

### DR-1 FLUID REGULATOR - PARTS LIST (Figure's 1 & 2)

Item #	Description	Part #	Qty
	<b>DR-1 Regulator Assembly</b>	<b>Select Options Below</b>	
	Ratio 1:1	74151-11	
	Ratio 1:2	74151-01	
	Ratio 1:3	74151-06	
	Ratio 1:4	74151-02	
	Ratio 1:6	74151-03	
	Ratio 1:8	74151-04	
	Ratio 1:10	74151-05	
1	Cap	74152-00	1
2	<b>Spacer Ring, For:</b>	<b>Select Options Below</b>	1
	Ratio 1:1	74153-11	
	Ratio 1:2	74153-01	
	Ratio 1:3	74153-06	
	Ratio 1:4	74153-02	
	Ratio 1:6	74153-03	
	Ratio 1:8	74153-04	
	Ratio 1:10	74153-05	
3	Lower Housing	74154	1
4	Screw, Socket Head Cap	8212-28F	8
5	<b>Upper Diaphragm Retainer, For:</b>	<b>Select Options Below</b>	1
	Ratio 1:1	74155-00	
	Ratio 1:2	75374-01	
	Ratio 1:3	75374-06	
	Ratio 1:4	75374-02	
	Ratio 1:6	75374-03	
	Ratio 1:8	74155-00	
	Ratio 1:10	74155-01	
6	Diaphragm Retainer, Lower	74156-00	1
7	Diaphragm Retainer, Center	74231-00	1
8*	Diaphragm, Lower	74273-00	1
9*	Diaphragm, Upper	74157-03	1
10*	<b>O-Ring</b>	<b>Select Options Below</b>	3
	.489" ID x .070" c/s, Solvent Resistant	7554-11	
	.489" ID x .070" c/s, Solvent Proof	79001-08 (Optional)	
11	Needle & Seat, Regulating	74160-00	1
12	Spring	74161-00	1
13	Retaining Plug	74162-00	1
14*	Diaphragm, Center	74157-04	1
15	Fitting, Air	7892-12	2

\* Parts contained in Repair Kit

(Continued On Next Page)

### DR-1 FLUID REGULATOR - PARTS LIST (Figure's 1 & 2) (Cont.)

Item #	Description	Part #	Qty
16*	Screw, Pan Head	74183-20C	1
17	Gasket	72135-00	2
18	Bleed Spacer	74232-00	1
20	<b>Paint Fitting (not included), For:</b>	<b>Select Options Below</b>	
	3/16" OD Tubing	70589-04	
	1/4" OD Tubing	70589-05	
	3/8" OD Tubing	70589-10	
	6mm OD Tubing	70589-06	
	8mm OD Tubing	70589-11	
	3/8" NPSM Hose Connection	70589-12	

\* Parts contained in Repair Kit

### RECOMMENDED SPARE PARTS

Part #	Description	Qty
74156-00	Diaphragm Retainer, Lower	1
74160-00	Needle and Seat, Regulating	1
74161-00	Spring	1

### SERVICE KITS

Part #	Description
73913-00	Repair Kit, W/Solvent Resistant O-Rings
73913-01	Repair Kit, W/Solvent Proof O-Rings

This page intentionally left blank.

**MANUAL CHANGE SUMMARY**

Date	Description	Version
03/2025	Rebranded to Binks.	R2

This page intentionally left blank.

## WARRANTY POLICY

This product is covered by Binks' materials and workmanship limited warranty.

The use of parts or accessories from sources other than Binks will void all warranties. Failure to follow reasonable maintenance guidance provided can invalidate the warranty.

For specific warranty information, please contact Binks.

---

For technical assistance or to locate an authorized distributor, contact one of our international sales and customer support locations listed below.

REGION	BINKS CONTACT
Americas	Tel: 1-800-445-3988
Europe, Africa, Middle East	Tel: +4401202571111
India	marketingroa@binks.com
China	Tel: +862133730108
Korea	Tel: +82313663303
Japan	Tel: +81457856421
Australia	Tel: +61085257555

## WARRANTY PAGE



# Binks

Binks is a global leader in innovative finishing technologies.  
Binks reserves the right to modify equipment specifications without prior notice.  
Binks®, DeVilbiss® and Ransburg® are registered trademarks of Binks US, LLC.