

---

## DR-1™ PLASTIC FLUID REGULATOR

---

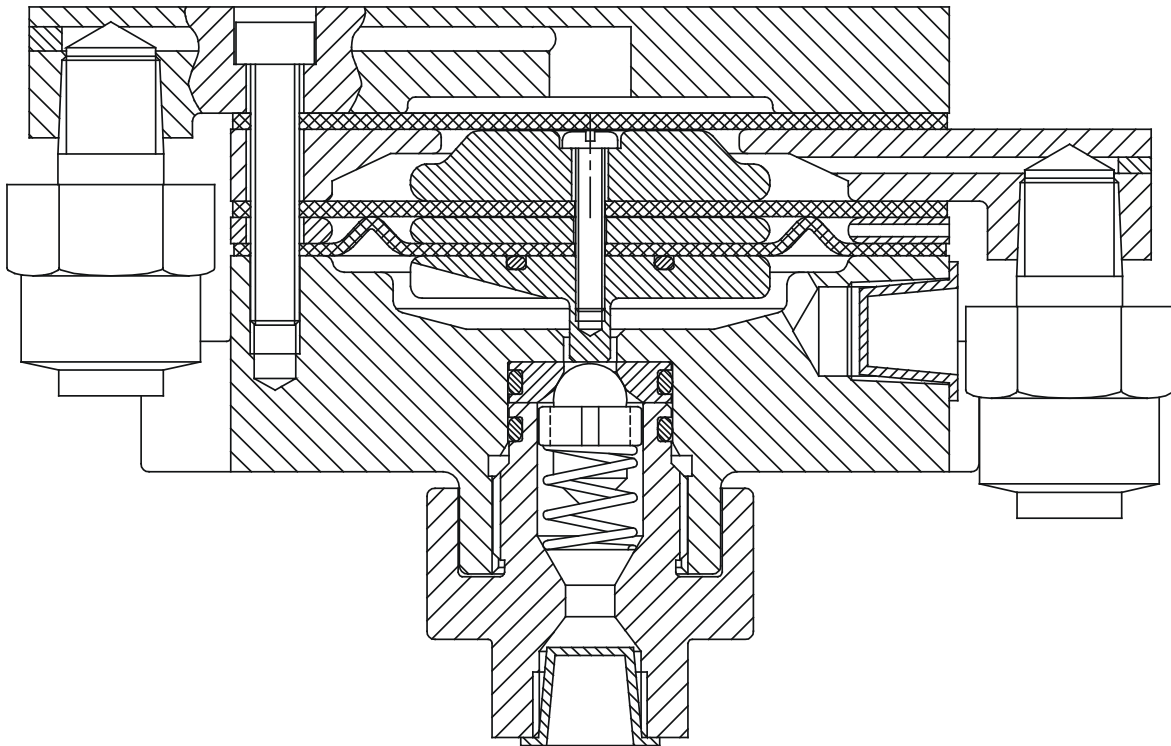

**MODEL: LREG5001**

---

**IMPORTANT:** Before using this equipment, carefully read **SAFETY PRECAUTIONS**, starting on page 1, and all instructions in this manual. Keep this Service Manual for future reference.

Service Manual Price: \$20.00 (U.S.)

**NOTE:** This manual has been changed from revision **LN-9221-00.6** to revision **LN-9221-00.7**. Reasons for this change are noted under “Manual Change Summary” inside the back cover of this manual.

---

# CONTENTS

---

	<b>PAGE</b>
<b>SAFETY:</b>	<b>1-5</b>
SAFETY PRECAUTIONS .....	1
HAZARDS / SAFEGUARDS .....	2-5
<b>INTRODUCTION:</b>	<b>6-12</b>
FEATURES .....	6
SPECIFICATIONS .....	6
DR-1 FLOW VS. SIGNAL PRESSURE .....	7
<b>OPERATION:</b>	<b>8</b>
OPERATION .....	8
<b>MAINTENANCE:</b>	<b>9-13</b>
TOOLS REQUIRED .....	9
PRELIMINARY PROCEDURES .....	9
DISASSEMBLY PROCEDURES .....	9
REGULATOR CROSS-SECTIONAL VIEW .....	10
ASSEMBLY PROCEDURES .....	11
TEST PROCEDURES .....	12
PREVENTIVE MAINTENANCE .....	12
TROUBLESHOOTING GUIDE .....	13
<b>PARTS IDENTIFICATION:</b>	<b>14-16</b>
REGULATOR CROSS-SECTIONAL VIEW / PARTS LIST .....	14-15
RECOMMENDED SPARE PARTS .....	16
SERVICE KITS.....	16
<b>WARRANTY POLICIES:</b>	<b>17</b>
LIMITED WARRANTY .....	17

# SAFETY

## SAFETY PRECAUTIONS

Before operating, maintaining or servicing any Ransburg electrostatic coating system, read and understand all of the technical and safety literature for your Ransburg products. This manual contains information that is important for you to know and understand. This information relates to USER SAFETY and PREVENTING EQUIPMENT PROBLEMS. To help you recognize this information, we use the following symbols. Please pay particular attention to these sections.

**A WARNING!** states information to alert you to a situation that might cause serious injury if instructions are not followed.

**A CAUTION!** states information that tells how to prevent damage to equipment or how to avoid a situation that might cause minor injury.

**A NOTE** is information relevant to the procedure in progress.

While this manual lists standard specifications and service procedures, some minor deviations may be found between this literature and your equipment. Differences in local codes and plant requirements, material delivery requirements, etc., make such variations inevitable. Compare this manual with your system installation drawings and appropriate Ransburg equipment manuals to reconcile such differences.

Careful study and continued use of this manual will provide a better understanding of the equipment and process, resulting in more efficient operation, longer trouble-free service and faster, easier troubleshooting. If you do not have the manuals and safety literature for your Ransburg system, contact your local Ransburg representative or Ransburg.



### WARNING



- The user **MUST** read and be familiar with the Safety Section in this manual and the Ransburg safety literature therein identified.
- This manual **MUST** be read and thoroughly understood by **ALL** personnel who operate, clean or maintain this equipment! Special care should be taken to ensure that the **WARNINGS** and safety requirements for operating and servicing the equipment are followed. The user should be aware of and adhere to **ALL** local building and fire codes and ordinances as well as **NFPA-33 SAFETY STANDARD, LATEST EDITION**, prior to installing, operating, and/or servicing this equipment.







### WARNING

- The hazards shown on the following pages may occur during the normal use of this equipment. Please read the hazard chart beginning on page 2.

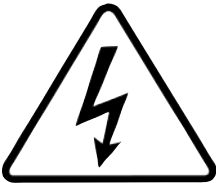
<p><b>AREA</b> Tells where hazards may occur.</p>	<p><b>HAZARD</b> Tells what the hazard is.</p>	<p><b>SAFEGUARDS</b> Tells how to avoid the hazard.</p>
<p><b>Spray Area</b></p> 	<p>Improper or inadequate operation and maintenance procedures will cause a fire hazard.</p> <p>Protection against inadvertent arcing that is capable of causing fire or explosion is lost if any safety interlocks are disabled during operation. Frequent Power Supply or Controller shutdown indicates a problem in the system requiring correction.</p>	<p>Fire extinguishing equipment must be present in the spray area and tested periodically.</p> <p>Spray areas must be kept clean to prevent the accumulation of combustible residues.</p> <p>Smoking must never be allowed in the spray area.</p> <p>The high voltage supplied to the atomizer must be turned off prior to cleaning, flushing or maintenance.</p> <p>When using solvents for cleaning:</p> <ul style="list-style-type: none"> <li>• Those used for equipment flushing should have flash points equal to or higher than those of the coating material.</li> <li>• Those used for general cleaning must have flash points above 100°F (37.8°C).</li> </ul> <p>Spray booth ventilation must be kept at the rates required by NFPA-33, OSHA, country, and local codes. In addition, ventilation must be maintained during cleaning operations using flammable or combustible solvents.</p> <p>Electrostatic arcing must be prevented. Safe sparking distance must be maintained between the parts being coated and the applicator. A distance of 1 inch for every 10KV of output voltage is required at all times.</p> <p>Test only in areas free of combustible material. Testing may require high voltage to be on, but only as instructed.</p> <p>Non-factory replacement parts or unauthorized equipment modifications may cause fire or injury.</p> <p>If used, the key switch bypass is intended for use only during setup operations. Production should never be done with safety interlocks disabled.</p> <p>Never use equipment intended for use in waterborne installations to spray solvent based materials.</p> <p>The paint process and equipment should be set up and operated in accordance with NFPA-33, NEC, OSHA, local, country, and European Health and Safety Norms.</p>

<p><b>AREA</b> Tells where hazards may occur.</p>	<p><b>HAZARD</b> Tells what the hazard is.</p>	<p><b>SAFEGUARDS</b> Tells how to avoid the hazard.</p>
<p><b>Spray Area</b></p> 	<p><b>Explosion Hazard</b></p> <p>Improper or inadequate operation and maintenance procedures will cause a fire hazard.</p> <p>Protection against inadvertent arcing that is capable of causing fire or explosion is lost if any safety interlocks are disabled during operation.</p> <p>Frequent Power Supply or Controller shutdown indicates a problem in the system requiring correction.</p>	<p>Electrostatic arcing must be prevented. Safe sparking distance must be maintained between the parts being coated and the applicator. A distance of 1 inch for every 10KV of output voltage is required at all times.</p> <p>Unless specifically approved for use in hazardous locations, all electrical equipment must be located <b>outside</b> Class I or II, Division 1 or 2 hazardous areas, in accordance with NFPA-33.</p> <p>Test only in areas free of flammable or combustible materials.</p> <p>The current overload sensitivity (if equipped) <b>MUST</b> be set as described in the corresponding section of the equipment manual. Protection against inadvertent arcing that is capable of causing fire or explosion is lost if the current overload sensitivity is not properly set. Frequent power supply shutdown indicates a problem in the system which requires correction.</p> <p>Always turn the control panel power off prior to flushing, cleaning, or working on spray system equipment.</p> <p>Before turning high voltage on, make sure no objects are within the safe sparking distance.</p> <p>Ensure that the control panel is interlocked with the ventilation system and conveyor in accordance with NFPA-33, EN 50176.</p> <p>Have fire extinguishing equipment readily available and tested periodically.</p>
<p><b>General Use and Maintenance</b></p> 	<p>Improper operation or maintenance may create a hazard.</p> <p>Personnel must be properly trained in the use of this equipment.</p>	<p>Personnel must be given training in accordance with the requirements of NFPA-33, EN 60079-0.</p> <p>Instructions and safety precautions must be read and understood prior to using this equipment.</p> <p>Comply with appropriate local, state, and national codes governing ventilation, fire protection, operation maintenance, and housekeeping. Reference OSHA, NFPA-33, EN Norms and your insurance company requirements.</p>

<p><b>AREA</b> Tells where hazards may occur.</p>	<p><b>HAZARD</b> Tells what the hazard is.</p>	<p><b>SAFEGUARDS</b> Tells how to avoid the hazard.</p>
<p><b>Spray Area / High Voltage Equipment</b></p> 	<p><b>Electrical Discharge</b></p> <p>There is a high voltage device that can induce an electrical charge on ungrounded objects which is capable of igniting coating materials.</p> <p>Inadequate grounding will cause a spark hazard. A spark can ignite many coating materials and cause a fire or explosion.</p>	<p>Parts being sprayed and operators in the spray area must be properly grounded.</p> <p>Parts being sprayed must be supported on conveyors or hangers that are properly grounded. The resistance between the part and earth ground must not exceed 1 meg ohm. (Refer to NFPA-33.)</p> <p>Operators must be grounded. Rubber soled insulating shoes should not be worn. Grounding straps on wrists or legs may be used to assure adequate ground contact.</p> <p>Operators must not be wearing or carrying any ungrounded metal objects.</p> <p>When using an electrostatic handgun, operators must assure contact with the handle of the applicator via conductive gloves or gloves with the palm section cut out.</p> <p><b>NOTE: REFER TO NFPA-33 OR SPECIFIC COUNTRY SAFETY CODES REGARDING PROPER OPERATOR GROUNDING.</b></p> <p>All electrically conductive objects in the spray area, with the exception of those objects required by the process to be at high voltage, must be grounded. Grounded conductive flooring must be provided in the spray area.</p> <p>Always turn off the power supply prior to flushing, cleaning, or working on spray system equipment.</p> <p>Unless specifically approved for use in hazardous locations, all electrical equipment must be located <b>outside</b> Class I or II, Division 1 or 2 hazardous areas, in accordance with NFPA-33.</p>

<b>AREA</b> Tells where hazards may occur.	<b>HAZARD</b> Tells what the hazard is.	<b>SAFEGUARDS</b> Tells how to avoid the hazard.
<b>Electrical Equipment</b> 	<b>Electrical Discharge</b> <p>High voltage equipment is utilized in the process. Arcing in the vicinity of flammable or combustible materials may occur. Personnel are exposed to high voltage during operation and maintenance.</p> <p>Protection against inadvertent arcing that may cause a fire or explosion is lost if safety circuits are disabled during operation.</p> <p>Frequent power supply shut-down indicates a problem in the system which requires correction.</p> <p>An electrical arc can ignite coating materials and cause a fire or explosion.</p>	<p>Unless specifically approved for use in hazardous locations, the power supply, control cabinet, and all other electrical equipment must be located outside Class I or II, Division 1 and 2 hazardous areas in accordance with NFPA-33 and EN 50176.</p> <p>Turn the power supply OFF before working on the equipment.</p> <p>Test only in areas free of flammable or combustible material.</p> <p>Testing may require high voltage to be on, but only as instructed.</p> <p>Production should never be done with the safety circuits disabled.</p> <p>Before turning the high voltage on, make sure no objects are within the sparking distance.</p>
<b>Toxic Substances</b> 	<p>Certain material may be harmful if inhaled, or if there is contact with the skin.</p>	<p>Follow the requirements of the Material Safety Data Sheet supplied by coating material manufacturer.</p> <p>Adequate exhaust must be provided to keep the air free of accumulations of toxic materials.</p> <p>Use a mask or respirator whenever there is a chance of inhaling sprayed materials. The mask must be compatible with the material being sprayed and its concentration. Equipment must be as prescribed by an industrial hygienist or safety expert, and be NIOSH approved.</p>
<b>Spray Area</b> 	<b>Explosion Hazard – Incompatible Materials</b> <p>Halogenated hydrocarbon solvents for example: methylene chloride and 1,1,1,-Trichloroethane are not chemically compatible with the aluminum that might be used in many system components. The chemical reaction caused by these solvents reacting with aluminum can become violent and lead to an equipment explosion.</p>	<p>Aluminum is widely used in other spray application equipment - such as material pumps, regulators, triggering valves, etc. Halogenated hydrocarbon solvents must never be used with aluminum equipment during spraying, flushing, or cleaning. Read the label or data sheet for the material you intend to spray. If in doubt as to whether or not a coating or cleaning material is compatible, contact your coating supplier. Any other type of solvent may be used with aluminum equipment.</p>

# INTRODUCTION

## FEATURES

- Two independently controlled flow pressure ranges.
- High flow range port for higher fluid deliveries.
- Low flow range for more precise control over lower fluid deliveries.
- Interchangeable low flow ratios (1:1, 1:2, 1:3, 1:4, 1:6, 1:8, 1:10) for precise control.
- Plastic and coated wetted parts for decreased color change time.
- Factory Mutual listed in conjunction with the Aerobell 33™.

## SPECIFICATIONS

### Environmental / Physical

<b>Height:</b>	4-1/2-inch (114mm) w/fittings
<b>Diameter:</b>	4-inch (102mm) w/fittings

### Mechanical

<b>Air Pressures:</b>	Variable by Control (Manual or Automatic)
<b>Fluid Input:</b>	100 psi (6.8 bar max.) (10 psi minimum above output pressure)
<b>Fluid Output:</b>	Variable by Ratio

### Pneumatic / Fluid Connections

<b>Air Pilot:</b>	1/8-inch NPT x 1/4-inch Tube (Low and High)
<b>Fluid In:</b>	7/16-20 UNF - 37° Flare 1/4-inch OD Tube, use LSFI0022-04, Fitting 3/8-inch OD Tube, use LSFI0022-07, Fitting
<b>Fluid Out:</b>	1/8-inch NPT 1/4-inch OD Tube, use LSFI0041-01, Fitting 3/8-inch OD Tube, use LSFI0041-02, Fitting

<b>Volume of Paint Held Within Regulator:</b>	5 cc
---	------

## DR-1 FLOW VS SIGNAL PRESSURE

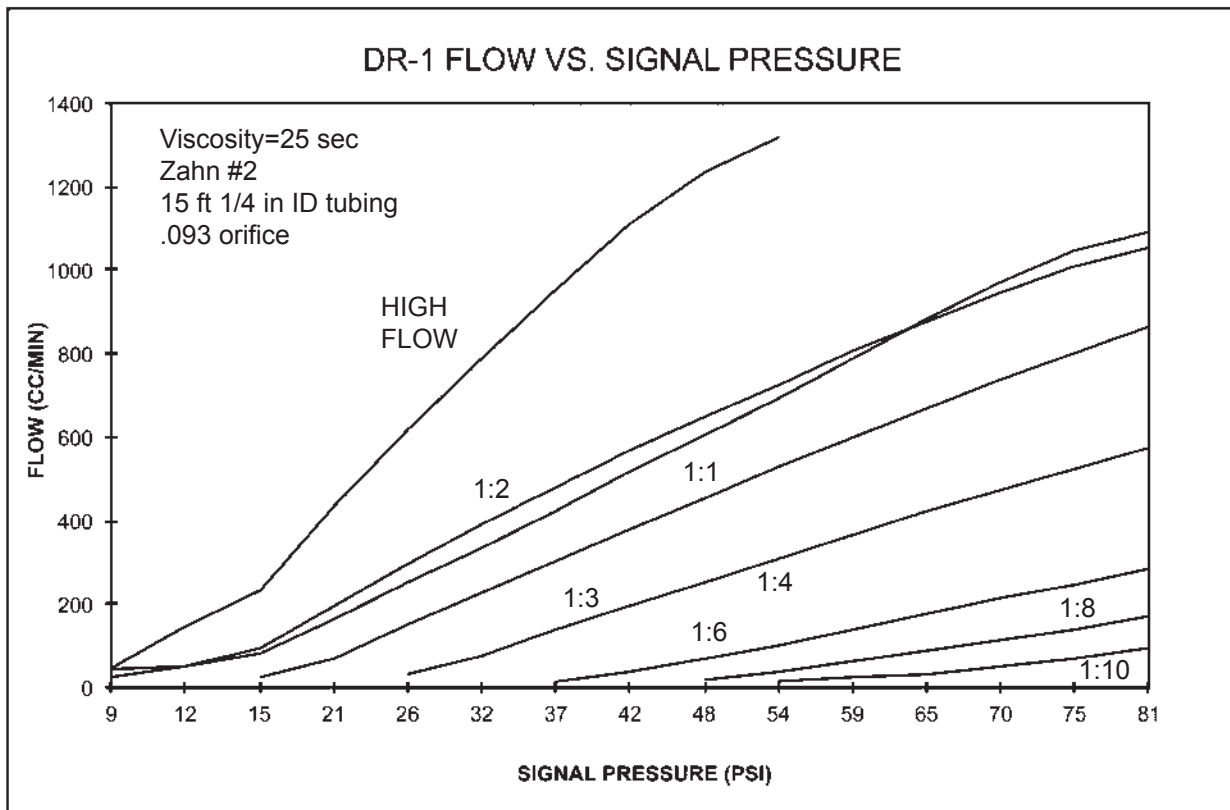
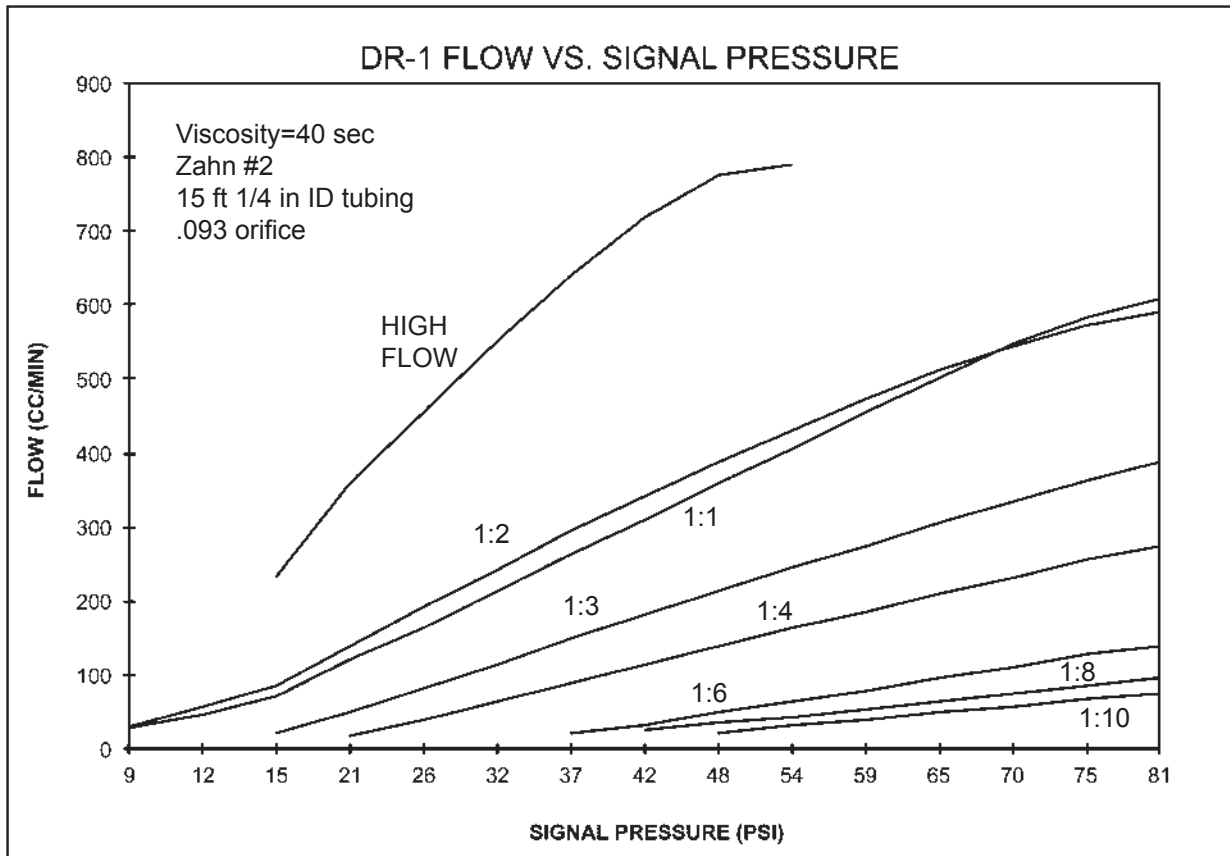

---

## OPERATION

---

The DR-1™ plastic regulator is designed to provide remote control fluid regulation for automatic coating applications.

The regulator features two independently controllable flow pressure ranges from the fluid output port. The high flow range port accommodates higher fluid deliveries and minimal color change times. The lower flow ranges provide precise fluid delivery control. There are seven lower range models available (1:1, 1:2, 1:3, 1:4, 1:6, 1:8, and 1:10) which can be selected based on the required fluid flow rate.

Separate pilot signals modulate each of the regulator's two diaphragms to control the amount of paint being delivered from the regulator to the spray applicator. These pilot signals can be controlled manually or automatically with Ransburg closed loop flow control systems.

Because of the regulator's dual range capabilities, it provides the user flexibility of selecting either the high flow range or the low flow range. Different coating material viscosities and quick color change requirements may necessitate the use of both ranges. If color change time is not a factor or if material viscosity remains relatively constant, either port may be used depending on flow rate requirements. All regulators, regardless of ratio designation, have the high flow port.

The low flow (i.e. 1:2, 1:4, etc.) port provides a lower, more precise flow response curve. Fluid output, as a result, is less likely to be affected by pilot signal errors. An increase in the ratio (i.e. from 1:2 to 1:4) provides a lower slope in the flow/air signal pressure curve, but, more precise response curve. This same increase in ratio, however, will reduce flow capacity and should be considered when selecting the proper regulator ratio.

The following factors must then be considered when selecting the regulator ratio required for proper fluid control:

- Fluid tubing inside diameter (ID) and length
- Fluid feed tube inside diameter (ID) and length
- Fluid viscosity
- Fluid input pressures

Preliminary testing will determine which regulator ratio should be used. If conditions change after installation which require a different low flow ratio, this regulator can be altered easily by replacing the existing ratio spacer ring and upper retainer with the desired ratio (ratio designation is etched on the side of the spacer ring).



### WARNING

► **NEVER** wrap the applicator, associated valves and tubing, and supporting hardware in plastic to keep it clean. A surface charge may build up on the plastic surface and discharge to the nearest grounded object. Efficiency of the applicator will also be reduced and damage or failure of the applicator components may occur. **WRAPPING THESE COMPONENTS IN PLASTIC WILL VOID WARRANTY.**

# MAINTENANCE

## TOOLS REQUIRED

- 3/4" Open End Wrench
- Adjustable Wrench
- Screwdriver
- Repair Kit, 73913-00

## PRELIMINARY PROCEDURES

Prior to removing the regulator for service or repair, perform the following:

1. If possible, flush the regulator with suitable cleaning solvent.
2. Turn the fluid and air "OFF" to the regulator and disconnect the air and fluid lines from the regulator.
3. Remove the regulator for service.

## DISASSEMBLY PROCEDURES (Refer to Figure 1)

### NOTE

- Unless replacing the cap or spacer ring, it is NOT necessary to remove the air fittings.
- The regulating needle and seat are a matched set with matching serial numbers. Care must be taken to not use needles and seats with non-matching serial numbers as fluid leakage may occur. If either component needs to be replaced, a new matched set must be used.

1. Remove Item 4 (8-screws) holding the regulator assembly together with the screwdriver.

2. Remove item 1 (cap), item 9 (diaphragm), spacer ring assembly and the lower housing assembly.

3. With screwdriver, remove Item 16 (screw) from the spacer ring assembly.



### CAUTION

- When separating parts it may be necessary to use a small screwdriver. Care should be taken to NOT damage the plastic components. Damage of these parts may cause leakage.

4. Separate Item 6 (lower diaphragm retainer), Item 10 (o-ring), item 8 (lower diaphragm), Item 17 (bleed spacer), Item 14 (center diaphragm) and, Item 5 (upper diaphragm retainer) from the spacer ring assembly.

5. With the 3/4" open end wrench, remove Item 13 (retaining plug), Item 12 (spring) and, Item 11 (regulating needle) from Item 3 (lower housing).

6. Remove Item 11 (regulating seat) and Item 10 (o-ring) from the lower housing assembly.

7. Clean all metal parts with suitable cleaning solvent. DO NOT use solvent on the diaphragms or o-rings.



### CAUTION

- Care MUST be taken while cleaning the coated parts of the regulator to prevent scratching.

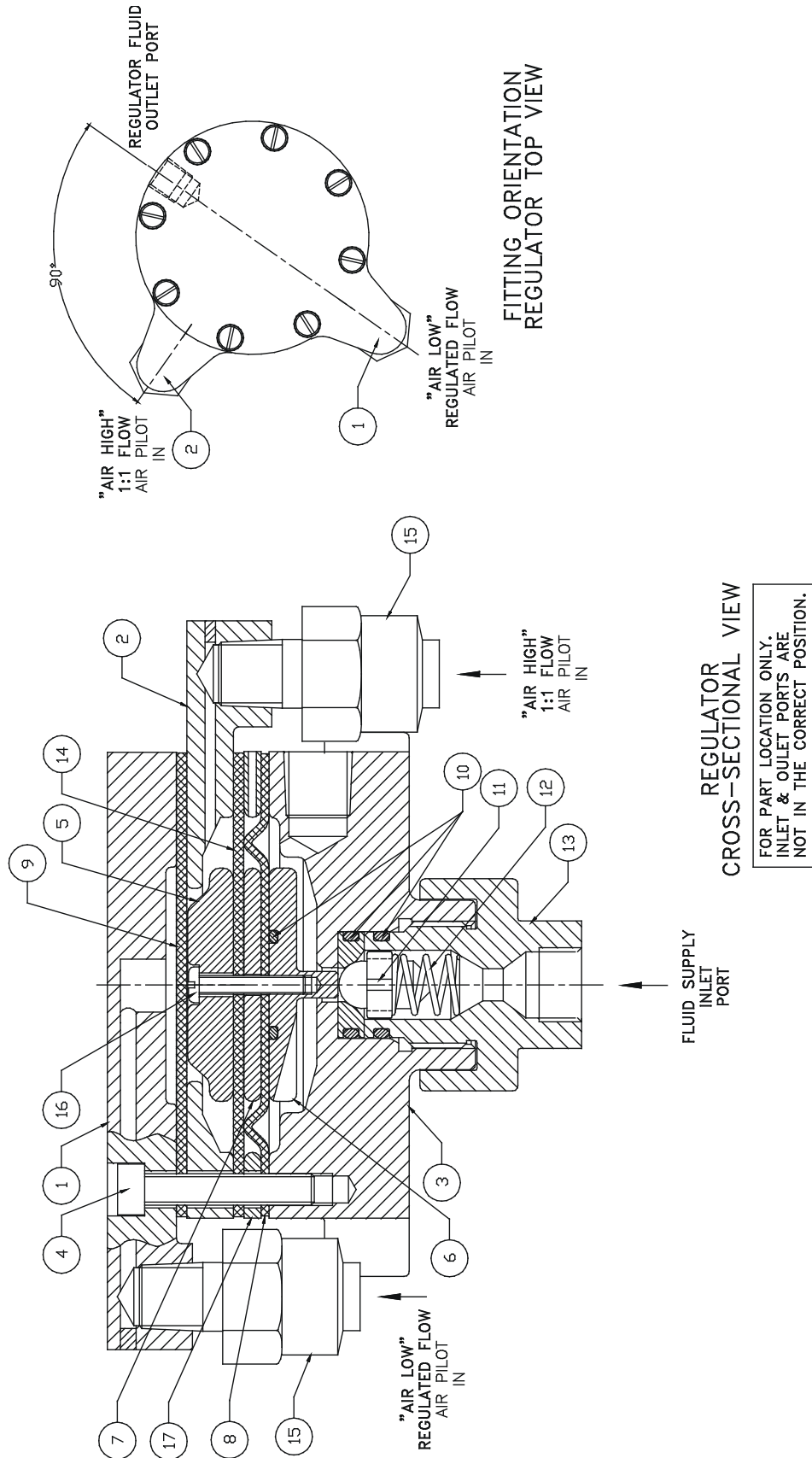

Figure 1: Regulator Cross-Sectional View

## ASSEMBLY PROCEDURES (Refer to Figure 1)

1. Place Item 10 (o-ring) in the slot on Item 6 (lower diaphragm retainer).
2. Place Item 8 (lower diaphragm) on the lower diaphragm retainer with the side of the diaphragm contacting the retainer (o-ring side).
3. Stack the following parts on the lower diaphragm, in the following order:
  - Item 7 (Center Diaphragm Retainer)
  - Item 17 (Bleed Spacer)
  - Item 14 (Center Diaphragm)
  - Item 5 (Upper Diaphragm Retainer)
  - Item 16 (Screw)
4. Ensure that clearance holes in Items 8 and 14 (diaphragms) and Item 17 (bleed spacer) are aligned properly and tighten Item 16 (screw). Use adhesive 222 on screw threads. Set this assembly



aside.

5. Place lower housing on table with bottom threaded opening facing "UP".
6. Insert Item 10 (o-ring) and Item 11 (regulating seat) into the lower housing. The beveled side of the regulating seat must be "UP".

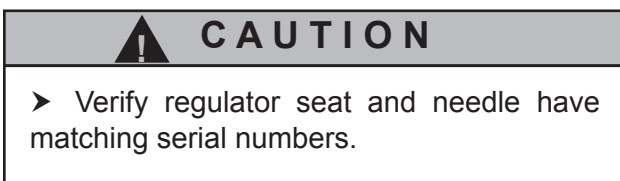

7. Place Item 11 (regulating needle) into lower housing with the ball end against Item 11 (regulating seat).

8. Place Item 10 (o-ring) on Item 13 (retaining plug).

9. Place Item 12 (spring) into lower housing over Item 11 (regulating needle) and thread Item 13 (retaining plug) into lower housing. Tighten Item 13 (retaining plug) ensuring that needle/spring remains in the center of the lower housing.

10. Place lower housing on table with bowl facing "UP" and place diaphragm assembly (from step 4), with pin facing "DOWN". Rotate the diaphragm assembly so that the slot on Item 6 (lower retainer) is 180° to the outlet port on the lower housing for cleaner flushing of paint.

11. Place Item 2 (spacer ring) on the top of the diaphragm assembly with largest opening facing "DOWN". Rotate the spacer ring, without rotating the diaphragm assembly, so that the inlet port of the spacer ring is 90° to the outlet port on the lower housing and all the clearance holes are aligned (see Figure 1).

12. Place Item 9 (diaphragm) on Item 2 (spacer ring) and align holes.

13. Place Item 1 (cap) on diaphragm. Rotate the cap, without rotating the diaphragm assembly, so that the inlet port of the cap is 90° from Item 2 (spacer ring) and 180° from the outlet port on the lower housing. Align holes and insert Item 4 (8-screws).

14. Tighten opposing screws alternately to 8 lbs•in, ensuring uniform sealing of the diaphragms. Then follow by tightening each screw in a circle pattern to 14-16 lbs•in.

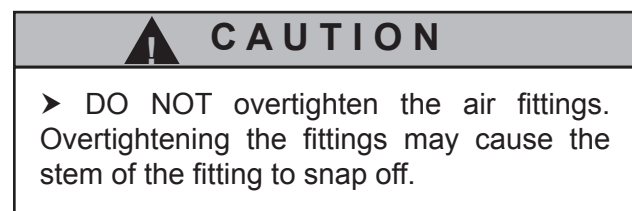

## TEST PROCEDURES (Refer to Figure 1)

After repair is complete, test the regulator in the following manner:

1. Set air and fluid regulators to zero and attach air and fluid lines to the regulator.
2. Gradually increase air pressure to the regulator to 80 psi, visually checking for leaks. Tighten Item 4 (screws) if leakage occurs.
3. Set air regulator to zero. Gradually increase fluid pressure to 80 psi, visually checking for leakage. Clean or replace Item 11 (needle and seat) if leakage at outlet port.

### NOTE

► If water or solvent is used for testing, it is normal for minor leakage to occur at the fluid output port, due to the low viscosities of these fluids.

4. Gradually increase air pressure on either of the air lines and visually observe a gradual increase in fluid flow. If regulator does not perform satisfactorily, inspect components for damage and replace where required.

## PREVENTIVE MAINTENANCE

1. Rebuild with 73913, repair kit, and 74160-00, needle and seat, at 6 months minimum, 12 months maximum.
2. Retorque (8) screws at the following intervals:
  - 2 days after rebuild
  - Immediately before installation
  - 6 month intervals

## NOTES

## TROUBLESHOOTING GUIDE

General Problem	Cause	Solution
<b>No Flow</b>	<ol style="list-style-type: none"> <li>1. Plugged inlet</li> <li>2. Item 11 (Needle and seat) stuck</li> <li>3. No pilot air</li> </ol>	<ol style="list-style-type: none"> <li>1. Flush clean</li> <li>2. Remove and clean or replace</li> <li>3. Check air pilot</li> </ol>
<b>Will Not Shut Off</b>	<ol style="list-style-type: none"> <li>1. Item 11 (Needle and seat) dirty</li> <li>2. Pilot air not shut off</li> </ol>	<ol style="list-style-type: none"> <li>1. Remove and clean or replace</li> <li>2. Check air supply</li> </ol>
<b>Paint Leakage</b>	<ol style="list-style-type: none"> <li>1. Item 4 (screws) loose</li> <li>2. Ruptured Item 8 (lower diaphragm)</li> <li>3. Loose fluid fittings</li> <li>4. Pinched Item 10 (o-ring)</li> </ol>	<ol style="list-style-type: none"> <li>1. Tighten per "Assembly Procedures"</li> <li>2. Rebuild regulator</li> <li>3. Tighten</li> <li>4. Replace</li> </ol>
<b>Air Leakage</b>	<ol style="list-style-type: none"> <li>1. Loose air fitting</li> <li>2. Item 4 (screws) loose</li> <li>3. Ruptured Item 14 (center diaphragm)</li> </ol>	<ol style="list-style-type: none"> <li>1. Tighten</li> <li>2. Tighten per "Assembly Procedure"</li> <li>3. Rebuild regulator</li> </ol>
<b>Inconsistent Flow</b>	<ol style="list-style-type: none"> <li>1. Incorrect regulator ratio used</li> <li>2. Diaphragm stretched from excessive air pressure</li> <li>3. Ruptured Item 9 (upper diaphragm)</li> <li>4. Inconsistent air pilot supply</li> <li>5. Low inlet fluid pressure</li> </ol>	<ol style="list-style-type: none"> <li>1. Refer to "Operation" section for correct sizing information</li> <li>2. Rebuild regulator</li> <li>3. Rebuild regulator</li> <li>4. Check air source</li> <li>5. Inlet pressure must be at least 10 psi above outlet pressure, 100 psi maximum</li> </ol>

# PARTS IDENTIFICATION

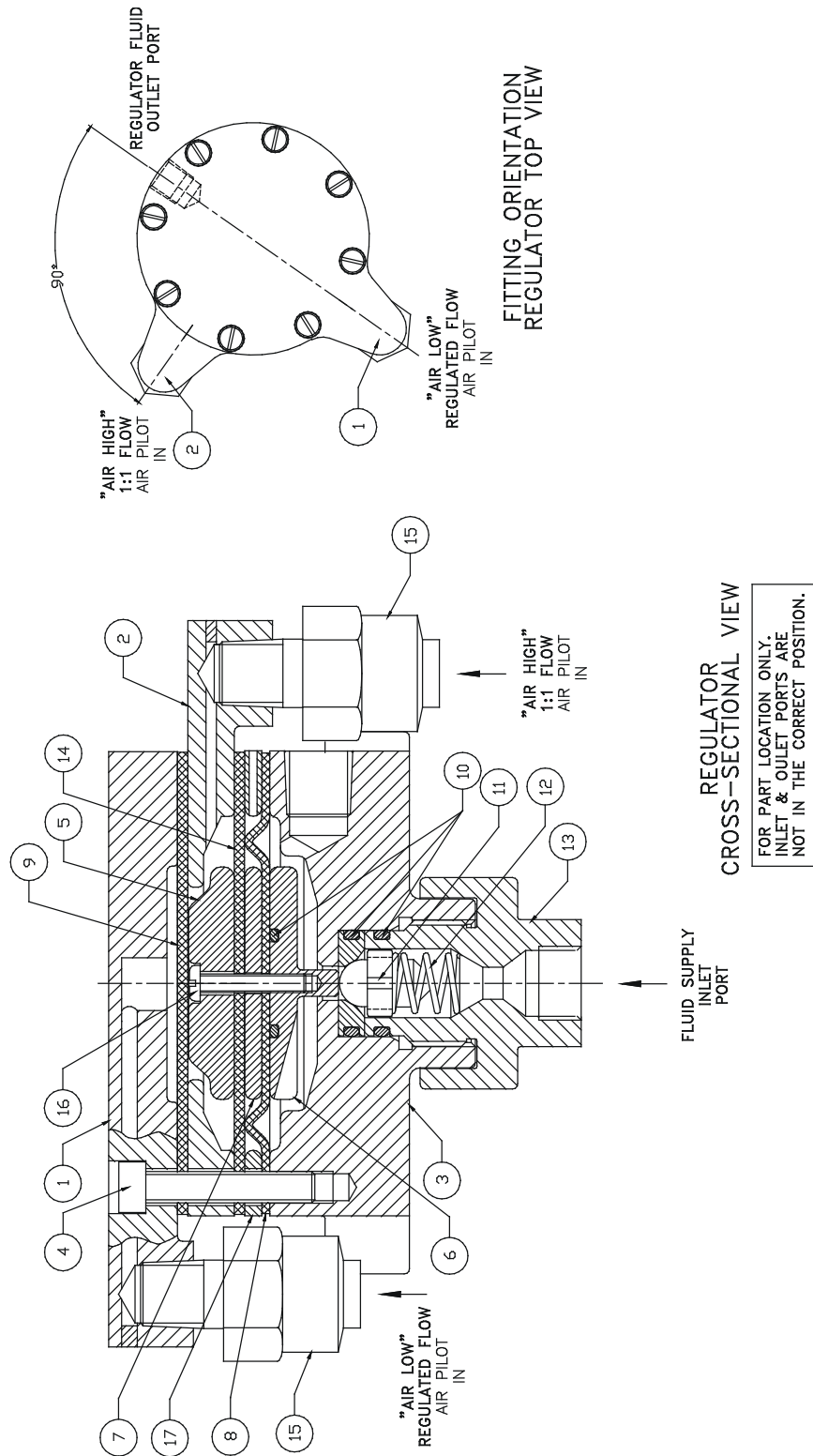

Figure 2: Regulator Cross-Sectional View

**DR-1 PLASTIC FLUID REGULATOR - PARTS LIST**  
**(Figures 1 and 3)**

Item #	Description	Part #	Qty
	<b>DR-1 Regulator Assembly</b> Ratio 1:1 (1/4-inch Tube) Ratio 1:2 (1/4-inch Tube) Ratio 1:3 (1/4-inch Tube) Ratio 1:4 (1/4-inch Tube) Ratio 1:6 (1/4-inch Tube) Ratio 1:8 (1/4-inch Tube) Ratio 1:10 (1/4-inch Tube) Ratio 1:1 (3/8-inch Tube) Ratio 1:2 (3/8-inch Tube) Ratio 1:3 (3/8-inch Tube) Ratio 1:4 (3/8-inch Tube) Ratio 1:6 (3/8-inch Tube) Ratio 1:8 (3/8-inch Tube) Ratio 1:10 (3/8-inch Tube)	<b>Select Options Below</b> LREG5001-01 LREG5001-02 LREG5001-03 LREG5001-04 LREG5001-06 LREG5001-08 LREG5001-10 LREG5001-11 LREG5001-12 LREG5001-13 LREG5001-14 LREG5001-16 LREG5001-18 LREG5001-20	
1	Cap	LREG0004-01	1
2	<b>Spacer Ring, For:</b> Ratio 1:1 Ratio 1:2 Ratio 1:3 Ratio 1:4 Ratio 1:6 Ratio 1:8 Ratio 1:10	<b>Select Options Below</b> LREG0003-01 LREG0003-02 LREG0003-03 LREG0003-04 LREG0003-06 LREG0003-08 LREG0003-10	1
3	Lower Housing	LREG0001	1
4	Screw, Slotted	LSFA0015-00	8
5	<b>Upper Diaphragm Retainer, For:</b> Ratio 1:1 Ratio 1:2 Ratio 1:3 Ratio 1:4 Ratio 1:6 Ratio 1:8 Ratio 1:10	<b>Select Options Below</b> 74155-00 75374-01 75374-06 75374-02 75374-03 74155-00 74155-01	1
6	Diaphragm Retainer, Lower	74156-00	1
7	Diaphragm Retainer, Center	74231-00	1
8*	Diaphragm, Lower	74273-00	1
9*	Diaphragm, Upper	74157-03	1
10*	<b>O-Ring</b> .489" ID x .070" C/S, Solvent Resistant .489" ID x .070" C/S, Solvent Proof	<b>Select Options Below</b> 7554-11 79001-08	3
11	Needle and Seat, Regulating	74160-00	1
12	Spring	74161-00	1
13	<b>Retaining Plug</b> For 1/4-inch Tube (Use with LSF10022-04 Fitting) For 3/8-inch Tube (Use with LSF10022-07 Fitting)	<b>Select Options Below</b> LREG0005-00 LREG0005-01	1
14*	Diaphragm, Center	74157-04	1

\* Parts contained in Repair Kit  
(Continued On Next Page)

<b>DR-1 PLASTIC FLUID REGULATOR - PARTS LIST (Cont.) (Figures 1 and 3)</b>			
<b>Item #</b>	<b>Description</b>	<b>Part #</b>	<b>Qty</b>
15	Fitting, Air	LSFI0013-03	2
16*	Screw, Pan Head	74183-20C	1
17	Bleed Spacer	LREG0002	1
20	<b>Paint Fitting (not included), For:</b> 1/4" OD Tubing 3/8" OD Tubing	<b>Select Options Below</b> LSFI0041-01 LSFI0041-02	

\* Parts contained in Repair Kit

<b>RECOMMENDED SPARE PARTS</b>		
<b>Description</b>	<b>Part #</b>	<b>Qty</b>
Diaphragm Retainer, Lower	74156-00	1
Needle and Seat, Regulating	74160-00	1
Spring	74161-00	1

<b>SERVICE KITS</b>	
<b>Description</b>	<b>Part #</b>
Repair Kit, W/Solvent Resistant O-Rings	73913-00
Repair Kit, W/Solvent Proof O-Rings	73913-01

---

# WARRANTY POLICIES

---

## LIMITED WARRANTY

Ransburg will replace or repair without charge any part and/or equipment that falls within the specified time (see below) because of faulty workmanship or material, provided that the equipment has been used and maintained in accordance with Ransburg's written safety and operating instructions, and has been used under normal operating conditions. Normal wear items are excluded.

### **THE USE OF OTHER THAN RANSBURG APPROVED PARTS, VOID ALL WARRANTIES.**

**SPARE PARTS:** One hundred and eighty (180) days from date of purchase, except for rebuilt parts (any part number ending in "R") for which the warranty period is ninety (90) days.

**EQUIPMENT:** When purchased as a complete unit, (i.e., guns, power supplies, control units, etc.), is one (1) year from date of purchase. **WRAPPING THE APPLICATOR, ASSOCIATED VALVES AND TUBING, AND SUPPORTING HARDWARE IN PLASTIC, SHRINK-WRAP, OR ANY OTHER NON-APPROVED COVERING, WILL VOID THIS WARRANTY.**

**RANSBURG'S ONLY OBLIGATION UNDER THIS WARRANTY IS TO REPLACE PARTS THAT HAVE FAILED BECAUSE OF FAULTY WORKMANSHIP OR MATERIALS. THERE ARE NO IMPLIED WARRANTIES NOR WARRANTIES OF EITHER MERCHANTABILITY OR FITNESS FOR A PARTICULAR PURPOSE. RANSBURG ASSUMES NO LIABILITY FOR INJURY, DAMAGE TO PROPERTY OR FOR CONSEQUENTIAL DAMAGES FOR LOSS OF GOODWILL OR PRODUCTION OR INCOME, WHICH RESULT FROM USE OR MISUSE OF THE EQUIPMENT BY PURCHASER OR OTHERS.**

**EXCLUSIONS:** If, in Ransburg's opinion the warranty item in question, or other items damaged by this part was improperly installed, operated or maintained, Ransburg will assume no responsibility for repair or replacement of the item or items. The purchaser, therefore will assume all responsibility for any cost of repair or replacement and service related costs if applicable.

---

# MANUAL CHANGE SUMMARY

---

This manual was published to replace Service Manual **LN-9221-00.6**, DR-1 Plastic Fluid Regulator, to make the following changes:

1. Change logo.

**Service Manual Price: \$20.00 (U.S.)**

---

**Manufacturing**

1910 North Wayne Street  
Angola, Indiana 46703-9100  
Telephone: 260/665-8800  
Fax: 260/665-8516

**Technical/Service Assistance**

Telephone: 800/233-3366  
Fax: 419/470-2071  
[www.ransburg.com](http://www.ransburg.com)

**Technical Support Representative will direct you to the appropriate telephone number for ordering Spare Parts.**

