

---

## DR-1™ PLASTIC FLUID REGULATOR

---

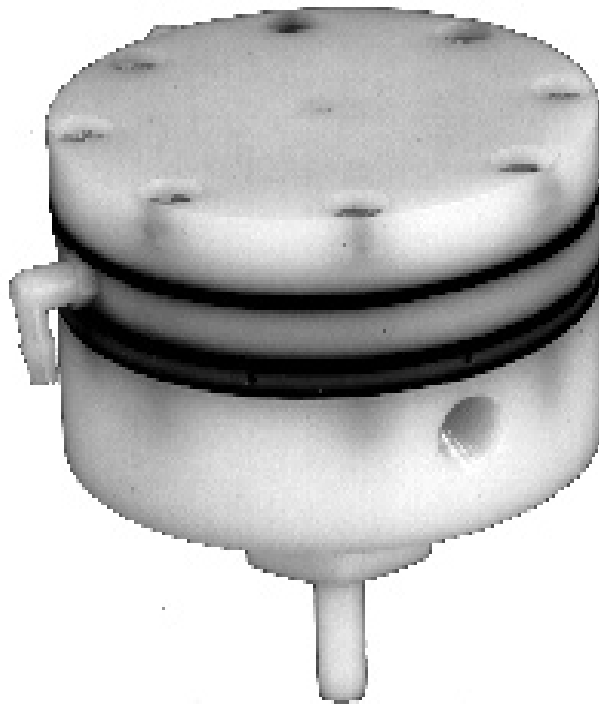

**MODEL: 75902**

---

**IMPORTANT:** Before using this equipment, carefully read **SAFETY PRECAUTIONS**, starting on page 1, and all instructions in this manual. Keep this Service Bulletin for future reference.

NOTE: This manual has been changed from revision LN-9228-00.2 to revision LN-9228-00.3. Reasons for this change are noted under "Manual Change Summary" inside the back cover of this manual.

---

## CONTENTS

---

	PAGE
<b>SAFETY:</b>	1-4
SAFETY PRECAUTIONS.....	1
HAZARDS / SAFEGUARDS.....	2-4
<b>INTRODUCTION:</b>	5-6
FEATURES.....	5
SPECIFICATIONS.....	5
DR-1 FLOW VS. SIGNAL PRESSURE.....	6
<b>OPERATION:</b>	7-8
OPERATION.....	7
<b>MAINTENANCE:</b>	9-14
TOOLS REQUIRED.....	9
PRELIMINARY PROCEDURES.....	9
DISASSEMBLY PROCEDURES.....	9
REGULATOR EXPLODED VIEW.....	10
ASSEMBLY PROCEDURES.....	11
FITTING ALIGNMENT.....	12
TEST PROCEDURES.....	12
PREVENTIVE MAINTENANCE.....	12
TROUBLESHOOTING GUIDE.....	13
<b>PARTS IDENTIFICATION:</b>	15-16
REGULATOR CROSS-SECTIONAL VIEW.....	15
DR-1 PLASTIC FLUID REGULATOR PARTS LIST / RECOMMENDED SPARE PARTS.....	16
<b>WARRANTY POLICIES:</b>	17
WARRANTY FOR THE DR-1 PLASTIC FLUID REGULATOR.....	17

# SAFETY

## SAFETY PRECAUTIONS

Before operating, maintaining or servicing any Ransburg electrostatic coating system, read and understand all of the technical and safety literature for your Ransburg products. This manual contains information that is important for you to know and understand. This information relates to **USER SAFETY** and **PREVENTING EQUIPMENT PROBLEMS**. To help you recognize this information, we use the following symbols. Please pay particular attention to these sections.

A **WARNING!** states information to alert you to a situation that might cause serious injury if instructions are not followed.

A **CAUTION!** states information that tells how to prevent damage to equipment or how to avoid a situation that might cause minor injury.

A **NOTE** is information relevant to the procedure in progress.

While this manual lists standard specifications and service procedures, some minor deviations may be found between this literature and your equipment. Differences in local codes and plant requirements, material delivery requirements, etc., make such variations inevitable. Compare this manual with your system installation drawings and appropriate Ransburg equipment manuals to reconcile such differences.

Careful study and continued use of this manual will provide a better understanding of the equipment and process, resulting in more efficient operation, longer trouble-free service and faster, easier troubleshooting. If you do not have the manuals and safety literature for your Ransburg system, contact your local Ransburg representative or Ransburg.



### WARNING

> The user **MUST** read and be familiar with the Safety Section in this manual and the Ransburg safety literature therein identified.



> This manual **MUST** be read and thoroughly understood by **ALL** personnel who operate, clean or maintain this equipment! Special care should be taken to ensure that the **WARNINGS** and safety requirements for operating and servicing the equipment are followed. The user should be aware of and adhere to **ALL** local building and fire codes and ordinances as well as **NFPA-33 SAFETY STANDARD**, prior to installing, operating, and/or servicing this equipment.



### WARNING

> The hazards shown on the following page may occur during the normal use of this equipment. Please read the hazard chart beginning on page 2.

<p>AREA</p> <p>Tells where hazards may occur.</p>	<p>HAZARD</p> <p>Tells what the hazard is.</p>	<p>SAFEGUARDS</p> <p>Tells how to avoid the hazard.</p>
<p>Spray Area</p> 	<p>Fire Hazard</p> <p>Improper or inadequate operation and maintenance procedures will cause a fire hazard.</p> <p>Protection against inadvertent arcing that is capable of causing fire or explosion is lost if any safety interlocks are disabled during operation. Frequent power supply shutdown indicates a problem in the system requiring correction.</p>	<p>Fire extinguishing equipment must be present in the spray area and tested periodically.</p> <p>Spray areas must be kept clean to prevent the accumulation of combustible residues.</p> <p>Smoking must never be allowed in the spray area.</p> <p>The high voltage supplied to the atomizer must be turned off prior to cleaning, flushing or maintenance.</p> <p>When using solvents for cleaning:</p> <p>Those used for equipment flushing should have flash points equal to or higher than those of the coating material.</p> <p>Those used for general cleaning must have flash points above 100°F (37.8°C).</p> <p>Spray booth ventilation must be kept at the rates required by NFPA- 33, OSHA, and local codes. In addition, ventilation must be maintained during cleaning operations using flammable or combustible solvents.</p> <p>Electrostatic arcing must be prevented.</p> <p>Test only in areas free of combustible material.</p> <p>Testing may require high voltage to be on, but only as instructed.</p> <p>Non-factory replacement parts or unauthorized equipment modifications may cause fire or injury.</p> <p>If used, the key switch bypass is intended for use only during set-up operations. Production should never be done with safety interlocks disabled.</p> <p>Never use equipment intended for use in waterborne installations to spray solvent based materials.</p> <p>The paint process and equipment should be set up and operated in accordance with NFPA-33, NEC, and OSHA requirements.</p>

AREA Tells where hazards may occur.	HAZARD Tells what the hazard is.	SAFEGUARDS Tells how to avoid the hazard.
General Use and Maintenance  	Improper operation or maintenance may create a hazard.  Personnel must be properly trained in the use of this equipment.	Personnel must be given training in accordance with the requirements of NFPA-33.  Instructions and safety precautions must be read and understood prior to using this equipment.  Comply with appropriate local, state, and national codes governing ventilation, fire protection, operation maintenance, and housekeeping. Reference OSHA, NFPA-33, and your insurance company requirements.
Electrical Equipment  	High voltage equipment is utilized. Arcing in areas of flammable or combustible materials may occur. Personnel are exposed to high voltage during operation and maintenance.  Protection against inadvertent arcing that may cause a fire or explosion is lost if safety circuits are disabled during operation.  Frequent power supply shut-down indicates a problem in the system which requires correction.  An electrical arc can ignite coating materials and cause a fire or explosion.	The power supply, optional remove control cabinet, and all other electrical equipment must be located outside Class I or II, Division 1 and 2 hazardous areas. Refer to NFPA-33.  Turn the power supply OFF before working on the equipment.  Test only in areas free of flammable or combustible material.  Testing may require high voltage to be on, but only as instructed.  Production should never be done with the safety circuits disabled.  Before turning the high voltage on, make sure no objects are within the sparking distance.
Explosion Hazard / Incompatible Materials  	Halogenated hydrocarbon solvents for example: methylene chloride and 1,1,1,-Trichloroethane are not chemically compatible with the aluminum that might be used in many system components. The chemical reaction caused by these solvents reacting with aluminum can become violent and lead to an equipment explosion.	Aluminum is widely used in other spray application equipment - such as material pumps, regulators, triggering valves, etc. Halogenated hydrocarbon solvents must never be used with aluminum equipment during spraying, flushing, or cleaning. Read the label or data sheet for the material you intend to spray. If in doubt as to whether or not a coating or cleaning material is compatible, contact your material supplier. Any other type of solvent may be used with aluminum equipment.

<b>AREA</b> Tells where hazards may occur.	<b>HAZARD</b> Tells what the hazard is.	<b>SAFEGUARDS</b> Tells how to avoid the hazard.
<p>Toxic Substances</p> 	<p>Certain material may be harmful if inhaled, or if there is contact with the skin.</p>	<p>Follow the requirements of the Material Safety Data Sheet supplied by coating material manufacturer.</p> <p>Adequate exhaust must be provided to keep the air free of accumulations of toxic materials.</p> <p>Use a mask or respirator whenever there is a chance of inhaling sprayed materials. The mask must be compatible with the material being sprayed and its concentration. Equipment must be as prescribed by an industrial hygienist or safety expert, and be NIOSH approved.</p>

# INTRODUCTION

## FEATURES

- Two independently controlled flow pressure ranges.
- High flow range port for higher fluid deliveries.
- Low flow range for more precise control over lower fluid deliveries.
- Interchangeable low flow ratios (1:1, 1:2, 1:3, 1:4, 1:6, 1:8, 1:10) for precise control.
- Plastic and coated wetted parts for decreased color change time.
- Factory Mutual listed in conjunction with the Aerobell 33™.

## SPECIFICATIONS

### Environmental / Physical

Height w/fittings:	Model B: 3-inches
Diameter:	3-3/4-inches w/fittings

### Mechanical

Air Pressures:	Variable by Control (Manual or Automatic)
Fluid Input:	100 psi (6.8 bar max.) (10 psi minimum above output pressure)
Fluid Output:	Variable by Ratio

### Pneumatic / Fluid Connections

Air Pilot:	10-32 x 3/16-inch OD Tube (Low & High)
Fluid In:	Model A: 1/4-inch OD Tube
Tube,	Model B: 1/4-inch OD Nut & Ferrule
Fluid Out:	1/8-inch NPT
Volume of Paint Held Within Regulator:	5 cc



## DR-1 FLOW VS SIGNAL PRESSURE

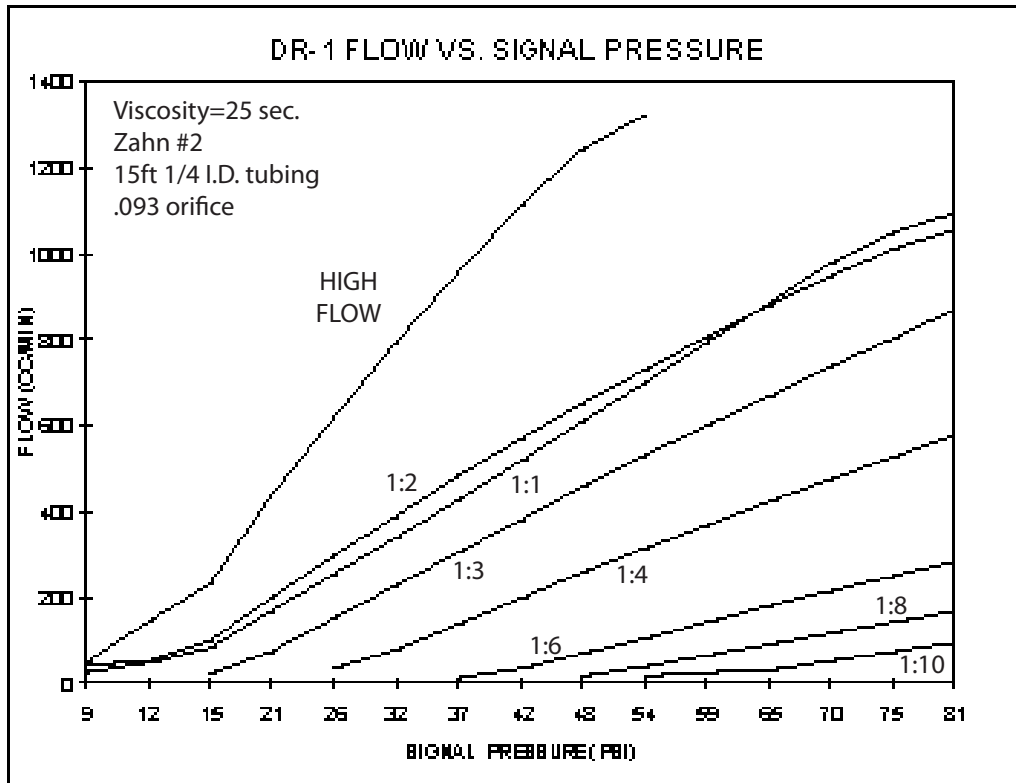
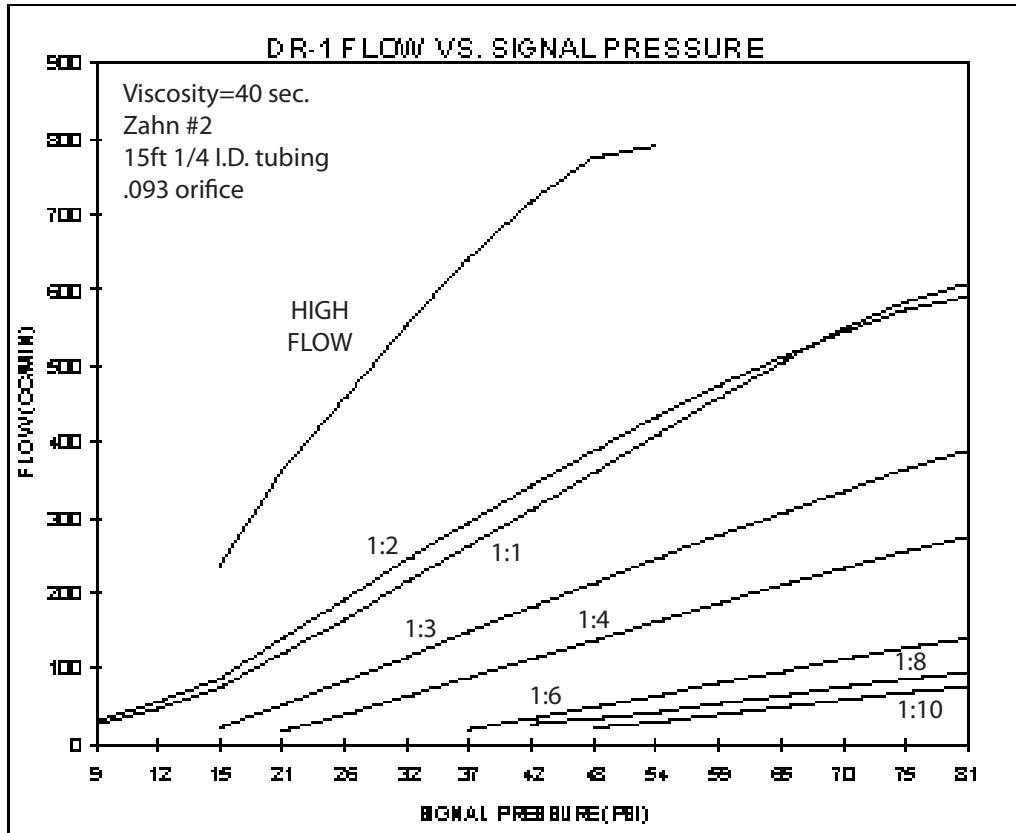

---

## OPERATION

---

The DR-1™ Plastic Regulator is designed to provide remote control fluid regulation for automatic coating applications.

The regulator features two independently controllable flow pressure ranges from the fluid output port. The high flow range port accommodates higher fluid deliveries and minimal color change times. The lower flow ranges provide precise fluid delivery control. There are seven lower range models available (1:1, 1:2, 1:3, 1:4, 1:6, 1:8, and 1:10) which can be selected based on the required fluid flow rate.

Separate pilot signals modulate each of the regulator's two diaphragms to control the amount of paint being delivered from the regulator to the spray applicator. These pilot signals can be controlled manually or automatically with the AdaptaFlow™ 5000, closed loop flow control system.

Because of the regulator's dual range capabilities, it provides the user flexibility of selecting either the high flow range or the low flow range. Different coating material viscosities and quick color change requirements may necessitate the use of both ranges. If color change time is not a factor or if material viscosity remains relatively constant, either port may be used depending on flow rate requirements. All regulators, regardless of ratio designation, have the high flow port.

The low flow (i.e. 1:2, 1:4, etc.) port provides a lower, more precise flow response curve. Fluid output, as a result, is less likely to be affected by pilot signal errors. An increase in the ratio (i.e. from 1:2 to 1:4) provides a lower slope in the flow/air signal pressure curve, but, more precise response curve. This same increase in ratio, however, will reduce flow capacity and should be considered when selecting the proper regulator ratio.

The following factors must then be considered when selecting the regulator ratio required for proper fluid control:

- Fluid tubing inside diameter (ID) and length
- Fluid feed tube inside diameter (ID) and length
- Fluid viscosity
- Fluid input pressures

Preliminary testing will determine which regulator ratio should be used. If conditions change after installation which require a different low flow ratio, this regulator can be altered easily by replacing the existing ratio spacer ring and upper retainer with the desired ratio (ratio designation is etched on the side of the spacer ring).

### NOTES

## MAINTENANCE

### TOOLS REQUIRED

- 3/4-inch Open End Wrench
- Adjustable Wrench
- Screwdriver
- Repair Kit, 73913-01

### PRELIMINARY PROCEDURES

Prior to removing the regulator for service or repair, perform the following:

1. If possible, flush the regulator with suitable cleaning solvent.
2. Turn the fluid and air "OFF" to the regulator and disconnect the air and fluid lines from the regulator.
3. Remove the regulator for service.

### DISASSEMBLY PROCEDURES

(Refer to Figure 1)

#### NOTE

- > Unless replacing the cap or spacer ring, it is NOT necessary to remove the air fittings.
- > The regulating needle and seat are a matched set with matching serial numbers. Care must be taken to not use needles and seats with non-matching serial numbers as fluid leakage may occur. If either component needs to be replaced, a new matched set must be used.

1. Remove Item 4 (8-screws) holding the regulator assembly together with the screwdriver.
2. Remove Item 1 (cap), Item 9 (diaphragm), spacer ring assembly and the lower housing assembly.



#### CAUTION

- > When separating parts it may be necessary to use a small screwdriver. Care should be taken to NOT damage the plastic components. Damage of these parts may cause leakage.

3. With screwdriver, remove Item 15 (screw) from the spacer ring assembly.
4. Separate Item 6 (lower diaphragm retainer), Item 10 (o-ring), Item 8 (lower diaphragm), Item 16 (bleed spacer), Item 14 (center diaphragm) and Item 5 (upper diaphragm retainer) from the spacer ring assembly.
5. With the 3/4-inch open-end wrench, remove Item 13 (retaining plug), Item 12 (spring) and Item 11 (regulating needle) from Item 3 (lower housing).
6. Remove Item 11 (regulating seat) and Item 10 (o-ring) from the lower housing assembly.
7. Clean all metal parts with suitable cleaning solvent. DO NOT use solvent on the diaphragms or o-rings.



#### CAUTION

- > Care MUST be taken while cleaning the coated parts of the regulator to prevent scratching.

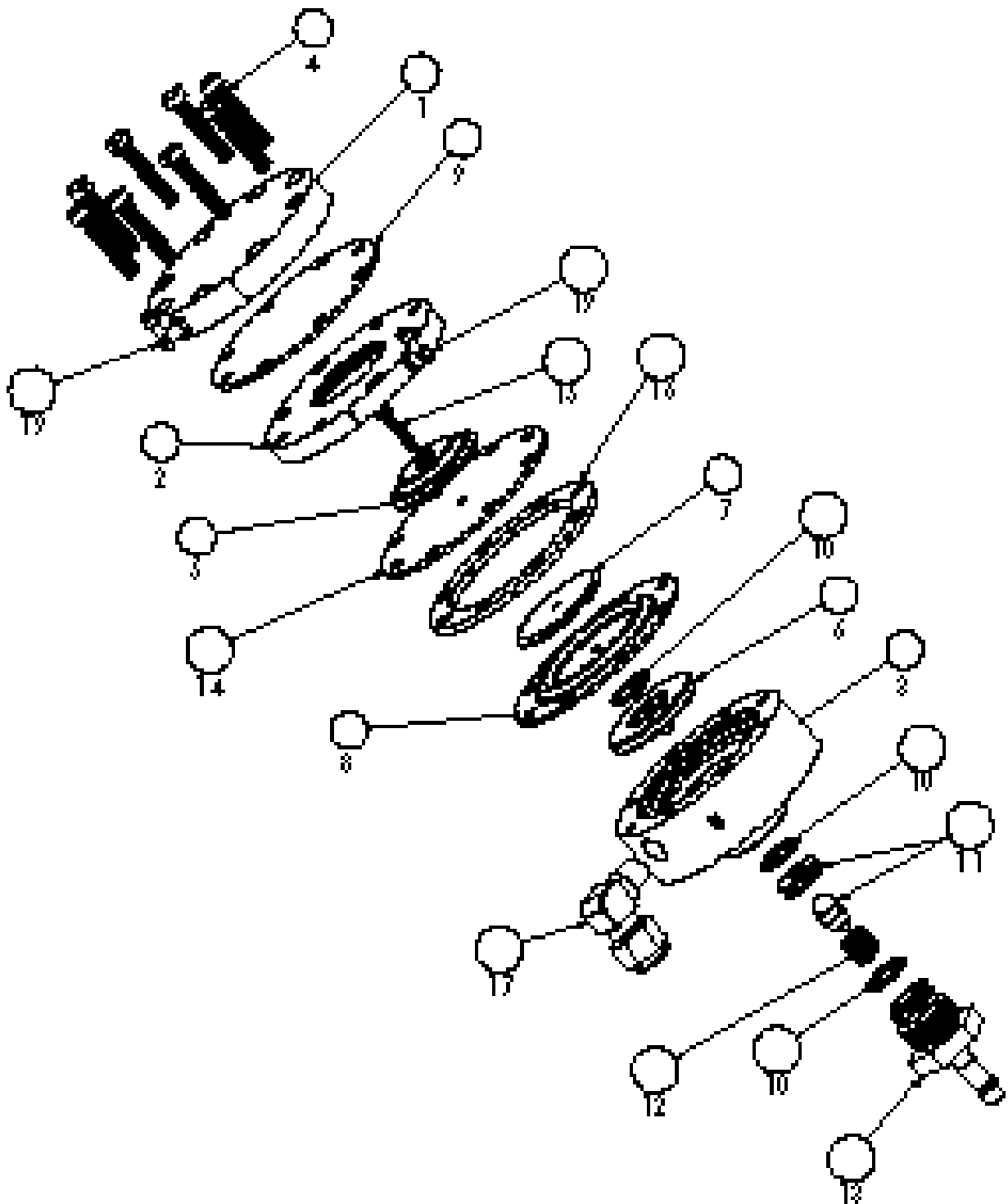

Figure 1: Regulator Exploded View

## ASSEMBLY PROCEDURES

(Refer to Figure 1)

1. Place Item 10 (o-ring) in the slot on Item 6 (lower diaphragm retainer).
2. Place Item 8 (lower diaphragm) on the lower diaphragm retainer with the side of the diaphragm contacting the retainer (o-ring side).
3. Stack the following parts on the lower diaphragm, in the following order:
  - Item 7 - Center Diaphragm Retainer
  - Item 16 - Bleed Spacer
  - Item 14 - Center Diaphragm
  - Item 5 - Upper Diaphragm Retainer
  - Item 15 - Screw
4. Ensure that clearance holes in Items 8 and 14 (diaphragms) and Item 16 (bleed spacer) are aligned properly and tighten Item 15 (screw). Use Loctite 222 on screw threads. Set this assembly aside.



5. Place lower housing on table with bottom threaded opening facing "UP".
6. Insert Item 10 (o-ring) and Item 11 (regulating seat) into the lower housing. The beveled side of the regulating seat must be "UP".

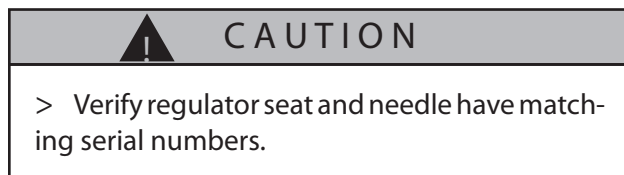

7. Place Item 11 (regulating needle) into lower housing with the ball end against Item 11 (regulating seat).

8. Place Item 10 (o-ring) on Item 13 (retaining plug).

9. Place Item 12 (spring) into lower housing over Item 11 (regulating needle) and thread Item 13 (retaining plug) into lower housing. Tighten Item 13 (retaining plug) ensuring that needle/spring remains in the center of the lower housing.

10. Place lower housing on table with bowl facing "UP" and place diaphragm assembly (from step 4), with pin facing "DOWN". Rotate the diaphragm assembly so that the slot on Item 6 (lower retainer) is 180° to the outlet port on the lower housing for cleaner flushing of paint.

11. Place Item 2 (spacer ring) on the top of the diaphragm assembly with largest opening facing "DOWN". Rotate the spacer ring, without rotating the diaphragm assembly, so that the alignment mark in the spacer ring is directly over the correct letter stamped on Item 3 (lower housing). (See Figure 2 for correct fitting alignment based on your applicator.)

12. Place Item 9 (diaphragm) on Item 2 (spacer ring) and align holes.

13. Place Item 1 (cap) on diaphragm. Rotate the cap, without rotating the diaphragm assembly, so that the alignment mark is in line with the mark on Item 2 (spacer ring) (see Figure 2).

14. Tighten opposing screws alternately to 8 lbs•in ensuring uniform sealing of the diaphragms. Then follow by tightening each screw in a circle pattern to 14-16 lbs•in.

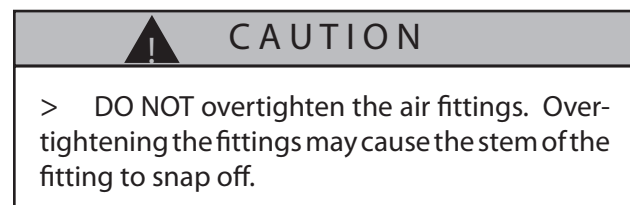

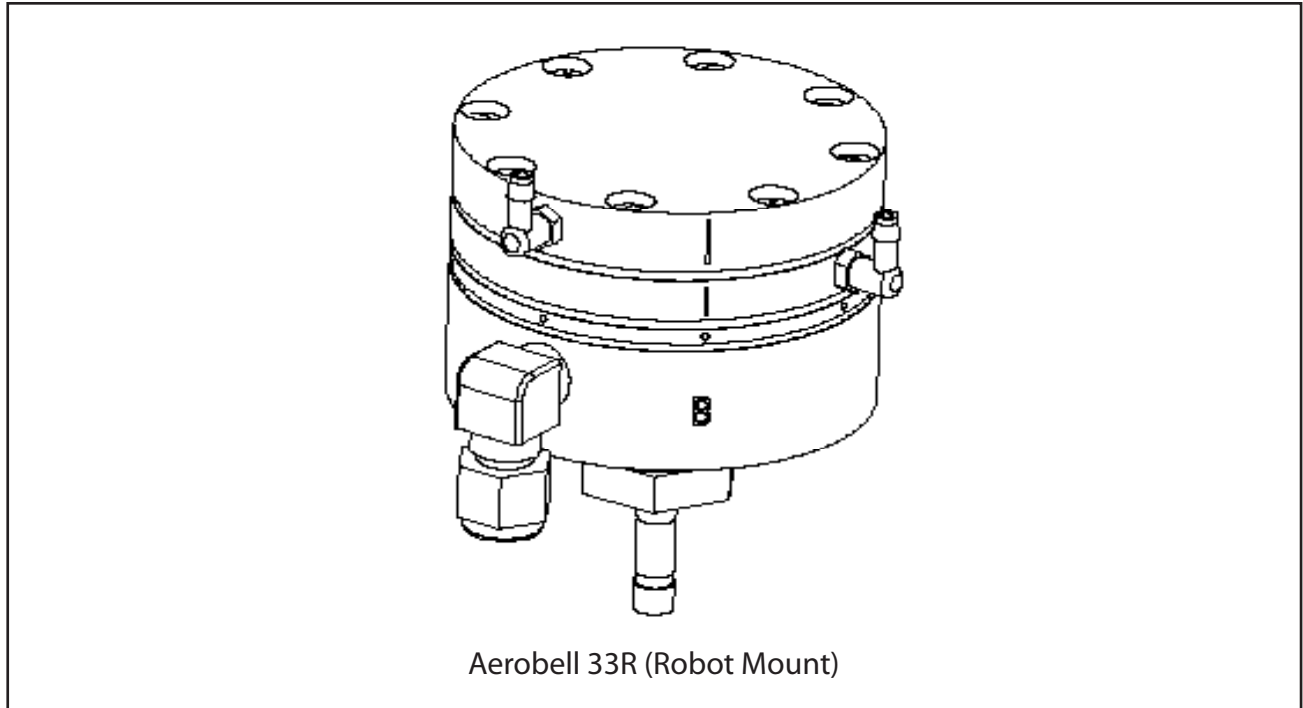

Figure 2: Fitting Alignment

## TEST PROCEDURES

(Refer to Figure 1)

After repair is complete, test the regulator in the following manner:

1. Set air and fluid regulators to zero and attach air and fluid lines to the regulator.
2. Gradually increase air pressure to the regulator to 80 psi, visually checking for leaks. Tighten Item 4 (screws) if leakage occurs.
3. Set air regulator to zero. Gradually increase fluid pressure to 80 psi, visually checking for leakage. Clean or replace Item 11 (needle and seat) if leakage at outlet port.

### NOTE

> If water or solvent is used for testing, it is normal for minor leakage to occur at the fluid output port, due to the low viscosities of these fluids.

4. Gradually increase air pressure on either of the air lines and visually observe a gradual increase in fluid flow. If regulator does not perform satisfactorily, inspect components for damage and replace where required.

## PREVENTIVE MAINTENANCE

1. Rebuild with 73913-01, repair kit, and 74160-00, needle and seat, at 6 months minimum, 12 months maximum.
2. Retorque eight (8) screws at the following intervals:
  - 2 days after rebuild
  - Immediately before installation
  - 6 month intervals

## TROUBLESHOOTING GUIDE

General Problem	Cause	Solution
No Flow	<ol style="list-style-type: none"> <li>1. Plugged inlet</li> <li>2. Item 11 (needle and seat) stuck</li> <li>3. No pilot air</li> </ol>	<ol style="list-style-type: none"> <li>1. Flush clean</li> <li>2. Remove and clean or replace</li> <li>3. Check air pilot</li> </ol>
Will Not Shut Off	<ol style="list-style-type: none"> <li>1. Item 11 (needle and seat) dirty</li> <li>2. Pilot air not shut off</li> </ol>	<ol style="list-style-type: none"> <li>1. Remove and clean or replace</li> <li>2. Check air supply</li> </ol>
Paint Leakage	<ol style="list-style-type: none"> <li>1. Item 4 (screws) loose</li> <li>2. Ruptured Item 8 (lower diaphragm)</li> <li>3. Loose fluid fittings</li> <li>4. Pinched Item 10 (o-ring)</li> </ol>	<ol style="list-style-type: none"> <li>1. Tighten per "Assembly Procedures"</li> <li>2. Rebuild regulator</li> <li>3. Tighten</li> <li>4. Replace</li> </ol>
Air Leakage	<ol style="list-style-type: none"> <li>1. Loose air fitting</li> <li>2. Item 4 (screws) loose</li> <li>3. Ruptured Item 14 (center diaphragm)</li> </ol>	<ol style="list-style-type: none"> <li>1. Tighten</li> <li>2. Tighten per "Assembly Procedure"</li> <li>3. Rebuild regulator</li> </ol>
Inconsistent Flow	<ol style="list-style-type: none"> <li>1. Incorrect regulator ratio used</li> <li>2. Diaphragm stretched from excessive air pressure</li> <li>3. Ruptured Item 9 (upper diaphragm)</li> <li>4. Inconsistent air pilot supply</li> <li>5. Low inlet fluid pressure</li> </ol>	<ol style="list-style-type: none"> <li>1. Refer to "Operation" section for correct sizing information</li> <li>2. Rebuild regulator</li> <li>3. Rebuild regulator</li> <li>4. Check air source</li> <li>5. Inlet pressure must be at least 10 psi above outlet pressure, 100 psi maximum</li> </ol>



### NOTES

# PARTS IDENTIFICATION

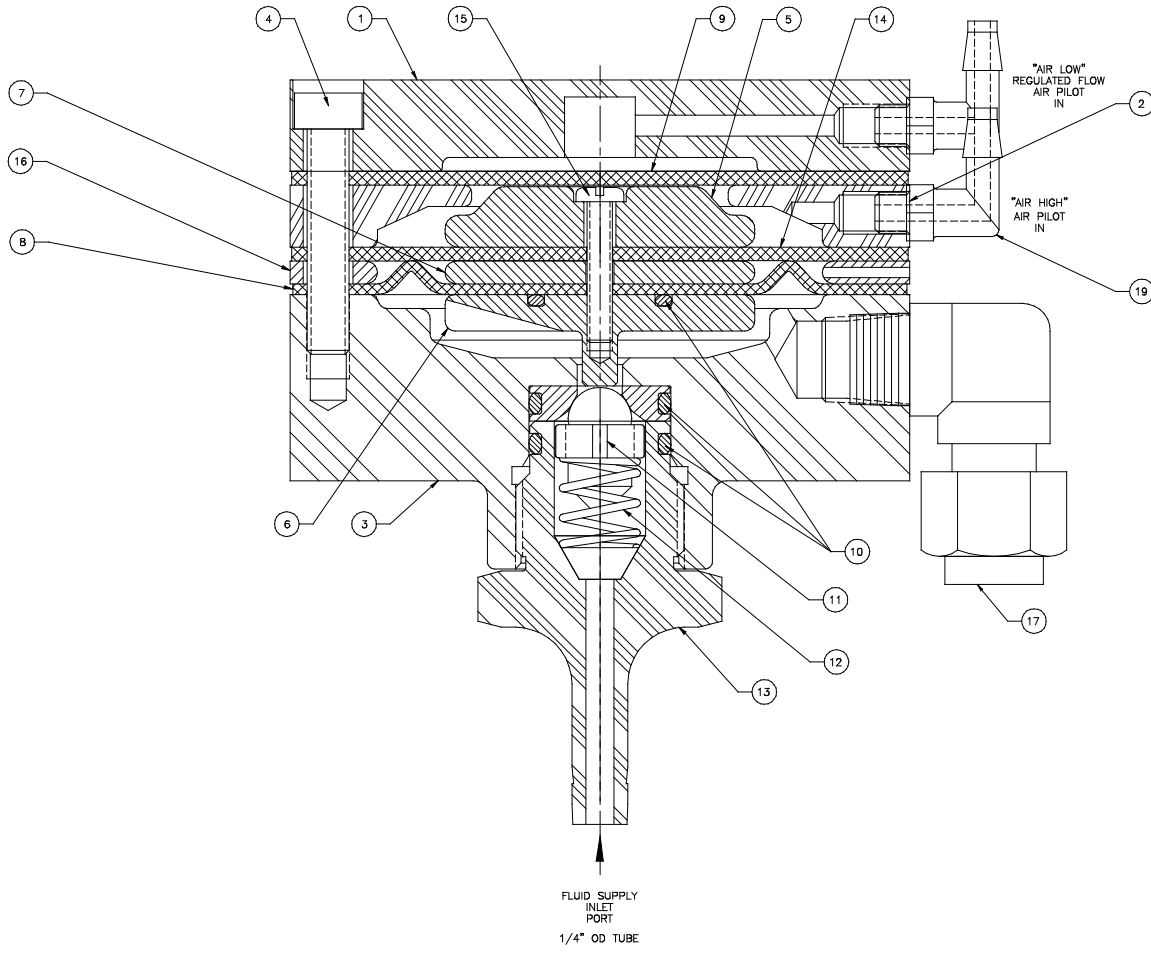

REGULATOR  
CROSS-SECTIONAL VIEW

FOR PART LOCATION ONLY.  
INLET & OUTLET PORTS ARE  
NOT IN THE CORRECT POSITION.

Figure 3: Regulator Cross-Sectional View

DR-1 PLASTIC FLUID REGULATOR - PARTS LIST (Figures 1 & 3)			
Item #	Part #	Description	Qty
Select Options Below		DR-1 Regulator Assembly***	
	75902-01	Ratio 1:1	
	75902-02	Ratio 1:2	
	75902-03	Ratio 1:3	
	75902-04	Ratio 1:4	
	75902-06	Ratio 1:6	
	75902-08	Ratio 1:8	
	75902-10	Ratio 1:10	
1	75881	Cap	1
Select Options Below		Spacer Ring, For:	
2	75880-01	Ratio 1:1	1
	75880-02	Ratio 1:2	1
	75880-03	Ratio 1:3	1
	75880-04	Ratio 1:4	1
	75880-06	Ratio 1:6	1
	75880-08	Ratio 1:8	1
	75880-10	Ratio 1:10	1
3	75879	Lower Housing	1
4**	LSFA0015-00	Screw, Slotted	8
Select Options Below		Upper Diaphragm Retainer, For:	
5	74155-00	Ratio 1:1	1
	75374-01	Ratio 1:2	1
	75374-06	Ratio 1:3	1
	75374-02	Ratio 1:4	1
	75374-03	Ratio 1:6	1
	74155-00	Ratio 1:8	1
	74155-01	Ratio 1:10	1
6**	74156-00	Diaphragm Retainer, Lower	1
7	74231-00	Diaphragm Retainer, Center	1
8*	74273-00	Diaphragm, Lower	1
9*	74157-03	Diaphragm, Upper	1
10*	SSG-8172	O-Ring	3
11**	74160-00	Needle and Seat, Regulating	1
12**	74161-00	Spring	1
13	75920	Retaining Plug, Aerobell 33R (Robot Mount)	1
14*	74157-04	Diaphragm, Center	1
15*	74183-20C	Screw, Pan Head	1
16	LREG0002	Bleed Spacer	1
17	LSFI0041-01	Elbow, 1/4" OD Tube x 1/8" NPT, Special Regulator Outlet	1
19**	75950-01	10-32 Right Angle Barb Fitting	2
20**	73913-01	Repair Kit	

\* Parts contained in Repair Kit

\*\* Recommended Spare Parts

\*\*\* Complete Regulator Part Number is 75902-XXA for Aerobell 33A (Fixed Mount) or 75902-XXB for Aerobell 33R (Robot Mount)

---

## WARRANTY POLICIES

---

### WARRANTY FOR THE DR-1 PLASTIC FLUID REGULATOR

The Ransburg DR-1 Plastic Fluid Regulator is warranted to be free of defects in workmanship and material. The terms of this warranty, except as hereinafter provided, extend from one year from the date of first installation. This excludes equipment failures which are the result of misapplication, misuse, incorrect maintenance, or normal wear. If, after inspection by Ransburg a defect is confirmed, we will at our option repair, replace or issue credit, minus allowance for usage received.

#### This Warranty Does NOT Cover:

1. Labor or incidental costs occasioned by removal, replacement or repair of the regulator by an unauthorized entity.
2. Regulators inspected and determined by Ransburg not to have been installed and maintained in accordance with Ransburg service manual for the DR-1 Plastic Fluid Regulator (75902) (latest edition).
3. Cost of repair/replacement and return transportation from Ransburg of merchandise determined not to be defective.

There is no other express warranty, implied warranties, including those of merchantability and fitness for a particular purpose are limited to one year from purchase and to the extent permitted by law any and all implied warranties are excluded. This is the exclusive remedy, and liability for consequential or incidental damages under any and all warranties are excluded to the extent exclusion is permitted by law. Some states do not allow limitations on how long an implied warranty lasts, or the limitation or exclusion of consequential or incidental damages, so the above limitation or exclusion may not apply to you.

This warranty gives you specific legal rights, and you may also have other rights which vary from state to state.

In the event of malfunction, first ensure that the equipment is the correct equipment to do the job required, is properly installed and adjusted, and is correctly maintained and operated. Then, if a claim is made that Ransburg equipment or a part thereof does not operate properly, contact your Ransburg distributor through which the equipment was purchased or your Ransburg representative.

---

# MANUAL CHANGE SUMMARY

This manual was published to replace Service Manual LN-9228-00.2 DR-1 Plastic Fluid Regulator, to make the following changes:

1. Change logo.

Manufacturing  
1910 North Wayne Street  
Angola, Indiana 46703-9100  
Telephone: 260/665-8800  
Fax: 260/665-8516

Technical/Service Assistance  
Automotive Assembly and Tier I  
Industrial Systems  
Ransburg Guns  
[www.ransburg.com](http://www.ransburg.com)

Telephone: 800/ 626-3565 Fax: 419/ 470-2040  
Telephone: 800/ 233-3366 Fax: 419/ 470-2071  
Telephone: 800/ 233-3366 Fax: 419/ 470-2071

Technical Support Representative will direct you to the appropriate telephone number for ordering Spare Parts.