

# **AEROBELL™ & AEROBELL PLUS™**

## **Rotary Atomizers**

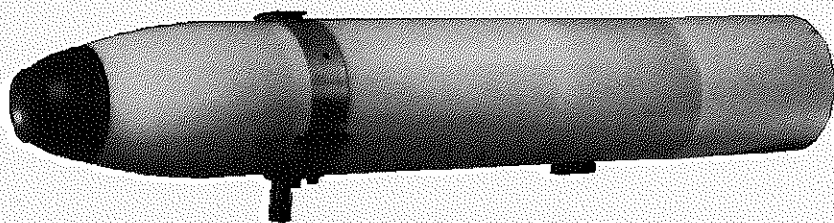

**AEROBELL PLUS™**

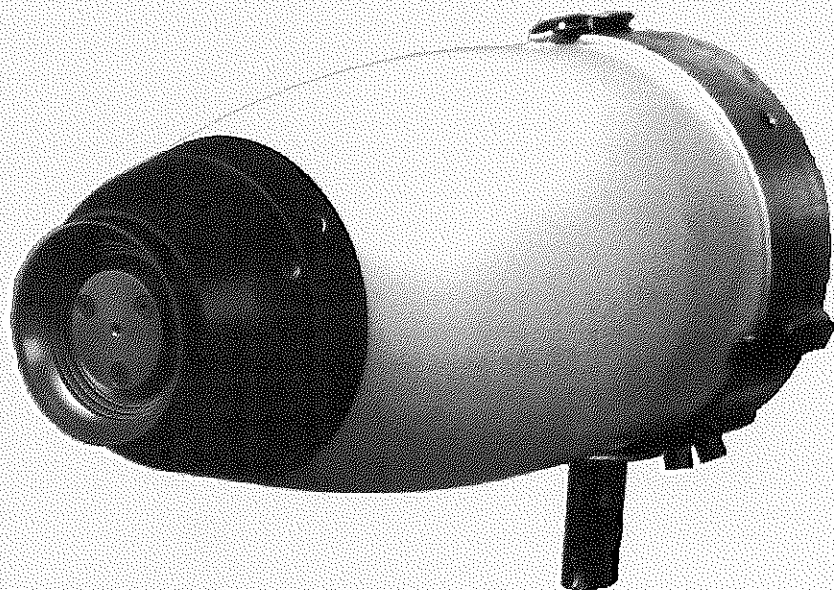

**AEROBELL™**

**IMPORTANT:** Before Operating this equipment, read all **SAFETY PRECAUTIONS** and all **Instructions** carefully.

U.S.A. AND FOREIGN PATENTS PENDING

# SAFETY PRECAUTIONS

This manual contains important information that ALL users should know and understand BEFORE using the equipment.

This information relates to USER SAFETY and PREVENTING EQUIPMENT PROBLEMS.

To help you recognize this information, we use the following terms to draw your attention to certain equipment labels and portions of this manual. Please pay special attention to any label or information that is highlighted by one of these terms:

## WARNING

Important information to alert you to a situation that might cause serious injury if instructions are not followed.

## CAUTION



Important information that tells how to prevent damage to equipment, or how to avoid a situation that might cause minor injury.



## Note

Information that you should pay special attention to.

## WARNING

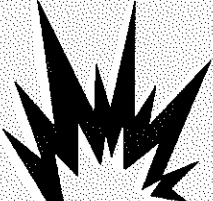
The following hazards may occur during the normal use of this equipment. Please read the following chart.

<b>AREA</b> Tells where hazards may occur.	<b>HAZARD</b> Tells what the hazard is.	<b>SAFEGUARDS</b> Tells how to avoid the hazard.
<b>Spray Area-High Voltage Equipment</b>  	This is a high voltage ungrounded device that can produce electrical arcs capable of igniting coating materials.	Parts being sprayed must be supported on conveyors or hangers and be grounded. The resistance between the part and ground must not exceed 1 megohm.  A safe distance must be maintained between the parts being coated and the atomizer bell. A distance of at least 1 inch for each 10 KV of power supply output voltage is required at all times.  Parts must be supported so that they will not swing and reduce the clearance specified above.  All electrically conductive objects in the spray area, with the exception of those objects required by the process to be at high voltage, must be grounded.  Unless specifically approved for use in hazardous locations, the power supply and other electrical equipment must not be used in Class I, Division 1 or 2 locations.
<b>Personnel Safety — Electrical Hazard</b>  	The high voltage equipment used in this application creates a hazard for personnel. The high voltage can cause injury, and a spark from the equipment to a person is capable of igniting coating material.	High voltage equipment must be isolated from personnel. Booths, fencing, railings or other means must be placed around the equipment and maintained to assure safe isolation of the process. The high voltage equipment must be deenergized prior to allowing personnel to enter the spray area.
<b>Explosion Hazard — Incompatible Materials</b>  	Halogenated hydrocarbon solvents for example: methylene chloride and 1,1,1,- Trichloroethane are not chemically compatible with the aluminum that might be used in many system components. The chemical reaction caused by these solvents reacting with aluminum can become violent and lead to an equipment explosion.	Aluminum is widely used in other spray application equipment — such as material pumps, regulators, triggering valves, etc. Halogenated hydrocarbon solvents must never be used with aluminum equipment during spraying, flushing, or cleaning. Read the label or data sheet for the material you intend to spray. If in doubt as to whether or not a coating or cleaning material is compatible — contact your material supplier. Any other type of solvent may be used with aluminum equipment.

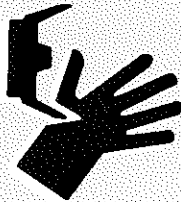
<b>AREA</b> Tells where hazards may occur.	<b>HAZARD</b> Tells what the hazard is.	<b>SAFEGUARDS</b> Tells how to avoid the hazard.				
<p style="text-align: center;"><b>Spray Area- Fire Hazard</b></p> 	<p>Improper or inadequate operations and maintenance procedures will cause a fire hazard.</p>	<p>Spray areas must be kept clean to prevent the accumulation of combustible residues.</p> <p>The high voltage supplied to the atomizer must be turned off prior to cleaning or maintenance.</p> <p>When using solvents for cleaning:</p> <ul style="list-style-type: none"> <li>• Those used for equipment flushing or purging must have flash points equal to or higher than those of the coating material.</li> <li>• Those used for equipment wipe-down or general cleaning must be nonflammable (flash point higher than 100°F/37.8°C) and also non-polar. Examples are:</li> </ul> <table style="width: 100%; border: none;"> <tr> <td style="text-align: center;">Amyl Acetate</td> <td style="text-align: center;">High Flash Naptha</td> </tr> <tr> <td style="text-align: center;">Methyl Amyl Acetate</td> <td style="text-align: center;">Mineral Spirits</td> </tr> </table> <p>Spray booth ventilation must be kept at the rates required by OSHA or local codes. In addition, ventilation must be maintained during cleaning operations using flammable or combustible solvents.</p>	Amyl Acetate	High Flash Naptha	Methyl Amyl Acetate	Mineral Spirits
Amyl Acetate	High Flash Naptha					
Methyl Amyl Acetate	Mineral Spirits					
<p style="text-align: center;"><b>Personnel Safety — Toxic Substances</b></p> 	<p>Certain materials may be harmful if inhaled, or if there is contact with the skin.</p>	<p>Read the labels or material safety data sheet for your coating material.</p> <p>If required, personal protection equipment must be suitable (NIOSH approved) for both the type and amount of toxic material to which the worker may be exposed.</p>				
<p style="text-align: center;"><b>Personnel Safety — Mechanical Hazards</b></p> 	<p>The atomizer rotates at speeds up to 60,000 RPM. At these speeds, the edge of the bell can easily cut into skin. Loose articles can also be caught by the rotating bell.</p>	<p>Personnel must stay clear of the bell whenever it is rotating.</p> <p>Before touching the bell, the turbine air must be shut off.</p> <p>If the bell has been rotating, allow at least three minutes for it to come to a complete stop before touching it. If the air brake feature is utilized, the bell can be stopped in a shorter period.</p>				
<p style="text-align: center;"><b>General Use and Maintenance</b></p>	<p>Personnel must be properly trained in the use of this equipment. Improper operation or maintenance can cause hazardous conditions.</p>	<p>Personnel must be given training in accordance with the requirements of NFPA-33, Chapter 15.</p> <p>Instructions and safety precautions must be read and understood prior to using this equipment.</p> <p>Comply with appropriate local, state, and national codes governing ventilation, fire protection, operation, maintenance, and housekeeping. OSHA reference is Section 1910.107. Also refer to NFPA-33 and your insurance company requirements.</p>				

## TABLE OF CONTENTS

<b>Description</b>	1	<b>Figures:</b>	
<b>Specifications</b>	1	Figure 1	AEROBELL™ & AEROBELL PLUS™ Rotary Atomizers 1
Air Filter Requirements	3		
Recommended Air Filtration	3		
<b>Installation</b>	4	Figure 2	AEROBELL™ Air System Recommendations 3
Air Filter Installation	4	Figure 3	Simplified AEROBELL™ Installation (Less PulseTrack Speed Monitor/Control) 5
Air & Fluid Connections	4		
Bearing Air	8		
Shaping Air	8	Figure 4	Simplified AEROBELL™ Installation (With PulseTrack Speed Monitor/Control) 5
Brake Air	8		
High Voltage	8		
AEROBELL™ & AEROBELL PLUS™ System Interlock Suggestions	8	Figure 5	AEROBELL™ & AEROBELL PLUS™ -- Air/Fluid Connections 6
<b>Operation</b>	9	Figure 6	RPM-415 One Valve Assembly (Trigger) 6
Turbine Speed	9		
Bearing Air	9	Figure 7	RPM-416 Two Valve Assembly (Trigger & Dump) 7
Brake Air	9		
Electrostatic Voltage	9		
Shaping Air	9	Figure 8	RPM-408 Two Valve Assembly (Trigger & Solvent) 7
Target Distance	9		
Materials Conductivity	10		
<b>Preventive Maintenance</b>	10	Figure 9	RPM-409 Three Valve Assembly (Trigger, Dump & Solvent) 7
Cleaning Procedures	10		
Vibration Noise	11	Figure 10	Atomizer Bell Removal 11
Air Filters — Element Replacement	11		
Felt Muffler	11	Figure 11	Wrench Placement 11
<b>Disassembly Procedures</b>	11	Figure 12	RPM-4 & 5 Shaping Air Cap/Ring Disassembly 12
Atomizer Bell Removal	11		
RPM-4 Shaping Cap/RPM-5 Shaping Air Ring Disassembly	12	Figure 13	AEROBELL™ Removal 12
Atomizer Bell Reassembly	12		
Quick Change AEROBELL™ Rotary Atomizer Removal	12	Figure 14	Quick Change AEROBELL™ Disassembly 12
Quick Change AEROBELL™ Rotary Atomizer Disassembly	12	Figure 15	AEROBELL™ Reassembly 13
AEROBELL™ Turbine Disassembly & Repair	13	Figure 16a	Exploded View Quick Change Rotary Atomizer 14
Quick Change AEROBELL™ Rotary Atomizer Reassembly	13	Figure 16b	Exploded View Quick Change Rotary Atomizer 14
<b>Warranty Policies</b>	19	Figure 17	AEROBELL PLUS™ Rear Shroud Assembly 16
<b>Worldwide Sales &amp; Service Listing</b>	20	Figure 18	AEROBELL PLUS™ Support Bracket & Tube Assembly 16
<b>Charts:</b>		Figure 19	AEROBELL PLUS™ Bearing Interlock Sub-assembly 16
Chart 1	AEROBELL™ & AEROBELL PLUS™ Models 2	Figure 20	RANS-PAK™ 100 Power Supply 17
Chart 2	Model Identification 2		
Chart 3	AEROBELL™ & AEROBELL PLUS™ Models Optional & Replacement Items 2		
Chart 4	AEROBELL™ & AEROBELL PLUS™ Models Fluid Tube Flow Rates 2		
Chart 5	Turbine Air Pressure -- RPM--SCFM 3		
Chart 6	AEROBELL™ & AEROBELL PLUS™ Models Recommended Air Filtration 3		
Chart 7	Braking Time (at 90 PSI Brake Air Pressure) 9		
Chart 8	Air Filters Replacement Elements 11		
Chart 9	Prepackaged Repair Kits 15		

# AEROBELL™ & AEROBELL PLUS™

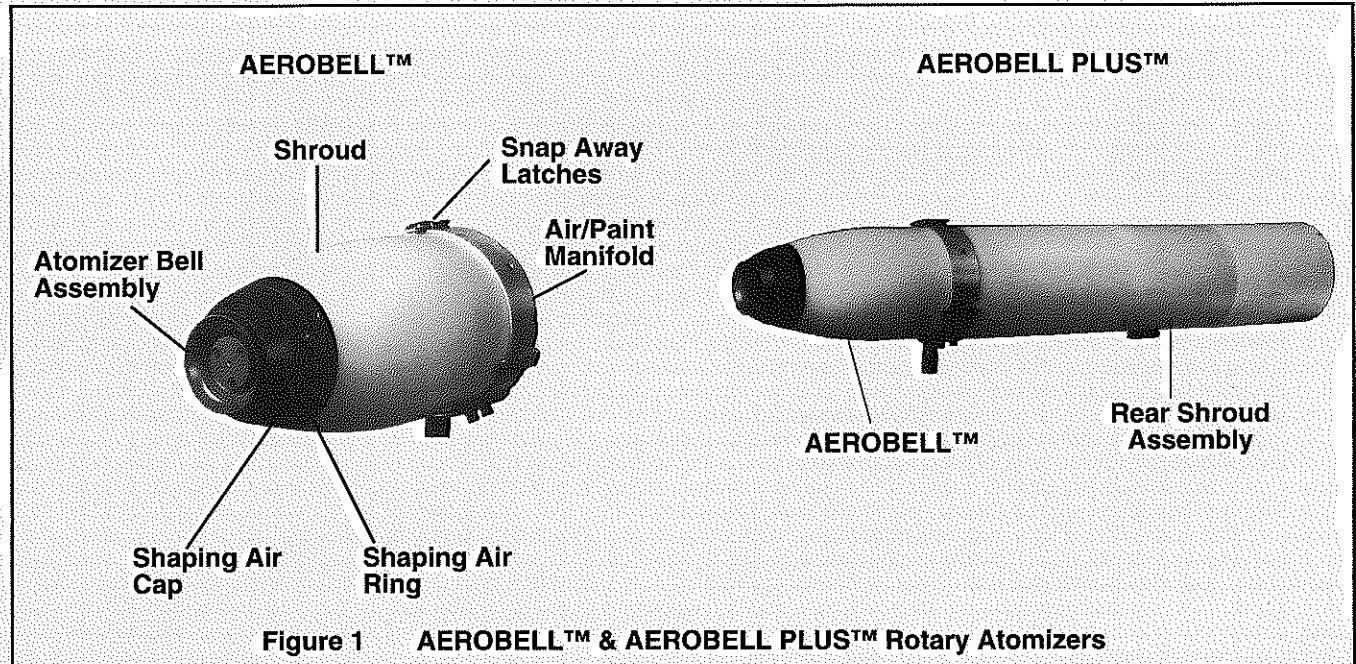

Figure 1 AEROBELL™ & AEROBELL PLUS™ Rotary Atomizers

## DESCRIPTION

The DeVilbiss Ransburg AEROBELL™ and AEROBELL PLUS™ are high speed bell type atomizers for electrostatic application of conventional and high solids coating materials. They are available in several combinations—see Chart 1 page 2. Contact your DeVilbiss Ransburg representative for assistance in atomizer bell selection.

The AEROBELL™ turbine assembly incorporates precision air type bearings for extended turbine life.

The AEROBELL PLUS™ turbine assembly is essentially the same as the AEROBELL™ with the addition of Rans-Pak 100™ technology. The Rans-Pak 100™ technology locates the cascade circuits near the atomizer assembly thus eliminating long high voltage cables.

### Features Include:

- Self cleaning bell
- Fast color change due to center feed fluid delivery and integral air brake
- Snap away latches for fast replacement of the rotary atomizer assembly
- Sleek configuration to facilitate cleaning of the exterior
- Shaping air annulus at bell edge for optimum pattern control
- Turbine air exhausts behind bell edge keeping paint and solvent contamination out of atomizer interior and back of bell clean
- Braking air capability
- Field repairable turbine assembly after the warranty period
- Magnetic pickup capability for speed readout

## SPECIFICATIONS

Turbine Speed	10,000-60,000 RPM (Max.)	
Turbine Type	Impulse	
<b>Weights</b>		
Aerobell™ Model	10.55 Lbs.	(4.79 kg)
Aerobell Plus™ Model	21.0 Lbs.	(9.54 kg)
Quick Change Only	7.0 Lbs.	(3.18 kg)
<b>Aerobell™ Length</b>	10 In.	(25.4 cm)
	(Approx. 11 in. with fittings)	
<b>Aerobell Plus™ Length</b>	30.75 In.	(78.1 cm)
<b>Diameter</b>	5.25 In.	(13.33 cm)
<b>*Air Pressures/ Air Consumptions</b>	<b>PSI</b>	<b>SCFM</b>
Turbine Air	45 Max.	18.0 (See Chart 5 on Page 3.)
Bearing Air	80 Nominal, 2-3 @ 80PSI 60 Min., 100 Max.	
Shaping Air	100 Max. 30 @ 100 PSI	
Brake Air	100 Nominal —	
Fluid Flow (Max.)	1000 CC's/Max. (60% Solids Paint, 30 Seconds Zahn # 3, with restrictive Orifice Removed)	
Fluid Pressure	150 PSI Max.	
Atomization Pattern	15 In. Min., 48 In. Max.	
Rotary Atomizer Change Time (Quick Change)	20 Sec. Approx.	
Bell Change Time	40 sec. Approx.	
Bell Cleaning Time	2-3 Sec. Approx.	
Speed Readout Pickup	Magnetic	
Warranty	See Page 19	

\*See "Air Filtration Requirements" on Page 3.





# AEROBELL™ & AEROBELL PLUS™

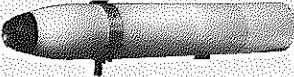

**Chart 1**  
**AEROBELL™ & AEROBELL™ PLUS Models**

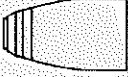
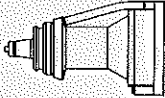
	
<b>Complete Standard Models</b>	<b>AEROBELL™ PLUS</b>
RPM-5062-PSC RPM-5062-PSP RPM-5062-PSE	RPM-5062-PRC RPM-5062-PRP RPM-5062-PRE
RPM-5093-PSC RPM-5093-PSP RPM-5093-PSE	RPM-5093-PRC RPM-5093-PRP RPM-5093-PRE
RPM-5125-PSC RPM-5125-PSP RPM-5125-PSE	RPM-5125-PRC RPM-5125-PRP RPM-5125-PRE

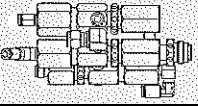
**Chart 3**  
**AEROBELL™ & AEROBELL™ PLUS Models Optional & Replacement Items**

		
<b>AEROBELL™ Quick Change Part No.</b>	<b>AEROBELL™ Air Bearing Turbine Model Number</b>	<b>Fluid Tube ID Size &amp; Part No.</b>
RPM-5062-PNC RPM-5062-PNP RPM-5062-PNE	RPM-406	0.062" (1/16") RPM-441
RPM-5093-PNC RPM-5093-PNP RPM-5093-PNE		0.093" (3/32") RPM-440
RPM-5125-PNC RPM-5125-PNP RPM-5125-PNE		0.125" (1/8") RPM-439
		
<b>Fluid Valve Combinations</b>		<b>External Fluid Regulators</b>
RPM-415 1 Valve Assembly (Trigger)		HGS 200 - 1000 cc/minute 24 Seconds, #4 Ford
RPM-416 2 Valve Assembly (Trigger/Dump)		HGS (Low Flow) 100 - 300 cc/minute 24 Seconds, #4 Ford
RPM-408 2 Valve Assembly (Trigger/Solvent)		DR-1 50 - 1400 cc/minute 25 Seconds, #2 Zahn
RPM-409 3 Valve Assembly (Trigger/Dump/Solvent)		

**Chart 2**  
**MODEL IDENTIFICATION**

**RPM-5XXX-XXX**

**Product Identification**

**Fluid Tube Size**  
0.093, 0.062, or 0.125"

**Shroud Type**  
P = RPM-3 Polyethylene

**Manifold Type**  
S = Standard Manifold (RPM-425)  
R = Aerobell Plus Manifold (LA0002)  
N = No Manifold

**Atomizer Bell Type**

C = RPM-449 Two Piece, Round Edge, Aluminum. (Includes RPM-4 Shaping Air Cap and RPM-5 Shaping Air Ring)

E = RPM-457 Two Piece, Sharp Serrated Edge, Hard Coat Anodized, Teflon Coated Step Bell. (Includes RPM-4 Shaping Air Cap and RPM-5 Shaping Air Ring)

P = RPM-452 One Piece, Sharp Serrated Edge, 30 MM, Hard Coat Anodized, Teflon Coated. (Includes RPM-79 Shaping Air Cap and RPM-80 Shaping Air Ring)

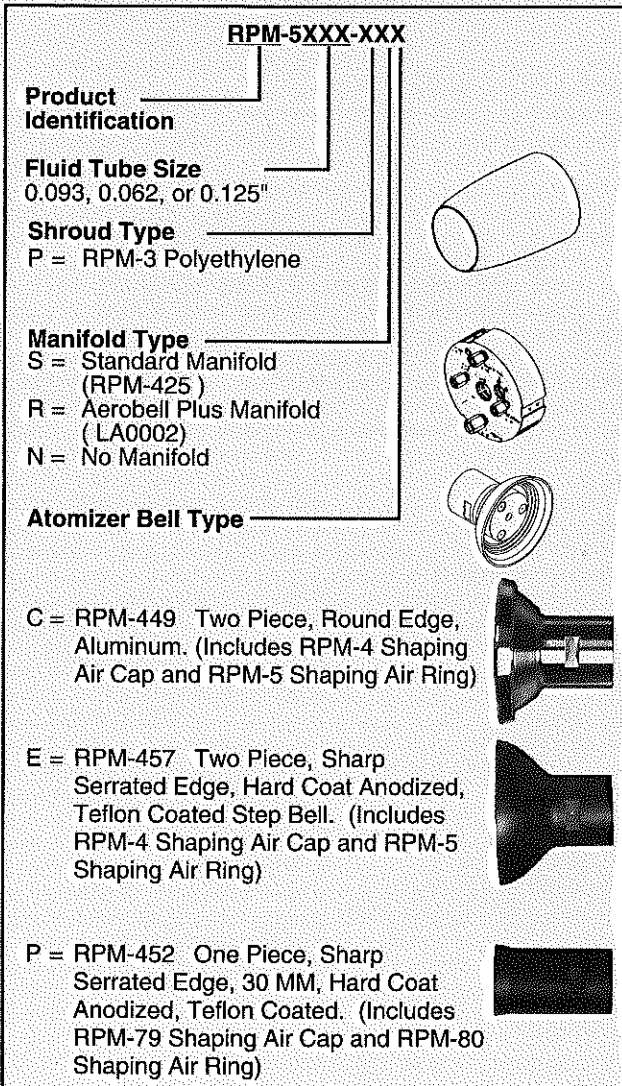

**Chart 4** **AEROBELL™ & AEROBELL™ PLUS Models Fluid Tube Flow Rates**

	
<b>Fluid Tube ID Size &amp; Part No.</b>	<b>Typical Flow Rates</b>
0.062" (1/16") RPM-441	250-800 CC/Min. (Viscosity 10-20 Sec. #4 Ford @ 30 PSI) Light Range Materials
0.093" (3/32") RPM-440	200-400 CC/Min. (Viscosity 25-35 Sec. #4 Ford @ 30 PSI) Medium Range Materials
0.125" (1/8") RPM-439	250-650 CC/Min. (Viscosity 30-50 Sec. #4 Heavy Range Materials)

# AEROBELL™ & AEROBELL PLUS™

## AIR FILTRATION REQUIREMENTS

**CAUTION**

Air must be properly filtered to assure extended turbine life and to prevent contamination of the paint job. Air which is not adequately filtered will foul the turbine air bearings and cause turbine failure. The correct type of filters must be used in an AEROBELL™ system. The filter elements must be replaced on a regular schedule to assure clean air.

It is the user's responsibility to insure clean air at all times. Turbine failure resulting from contaminated air will not be covered under warranty. The following **pre-filter** and **bearing air filter(s)** (See Chart 6) are recommended for use in AEROBELL™ systems. See Chart 6 if other filters are incorporated in the system -- the

filters to be used **must** have filtering capacities equal to or greater than those shown in Chart 6.

**Chart 5**  
Turbine Air Pressure — RPM — SCFM

PSI	RPM (unloaded)	SCFM
45	60,000 (MAX.)	18.0
40	56,000	15.8
35	52,600	14.2
30	48,300	13.0
25	43,400	11.4
20	37,700	9.7
15	31,000	7.9
10	23,000	6.1
5	13,000	3.9

**Chart 6** AEROBELL™ & AEROBELL PLUS™ Models Recommended Air Filtration

DeVilbiss Ransburg Filter Model No.	Description/ Specifications	Replacement Air Element Part No.
<b>HAF-515</b> (Used in systems with "Poor Air Quality")	Pre-filter, removes coarse amounts of oil, moisture & dirt. Used upstream of RPM-417 pre-filter.	HAF-5 Element, One
<b>RPM-417</b> (Depending upon SCFM required per AEROBELL™, one RPM-417 can be used with up to three AEROBELLS)	Pre-filter, coalescing type, 136 SCFM, 98.5% efficiency particulate removal .3 to .6 micron, max. aerosol passed 1.0 micron, max. solid passed .4 micron.	RPM-32 Elements, Carton of 4
<b>RPM-418</b> (One RPM-418 used per AEROBELL™)	Bearing air filter, coalescing type, 19 SCFM, 99.995% efficiency particulate removal .3 to .6 micron, max. aerosol passed .6 micron, max. solid passed .2 micron.	RPM-33 Elements, Carton of 8

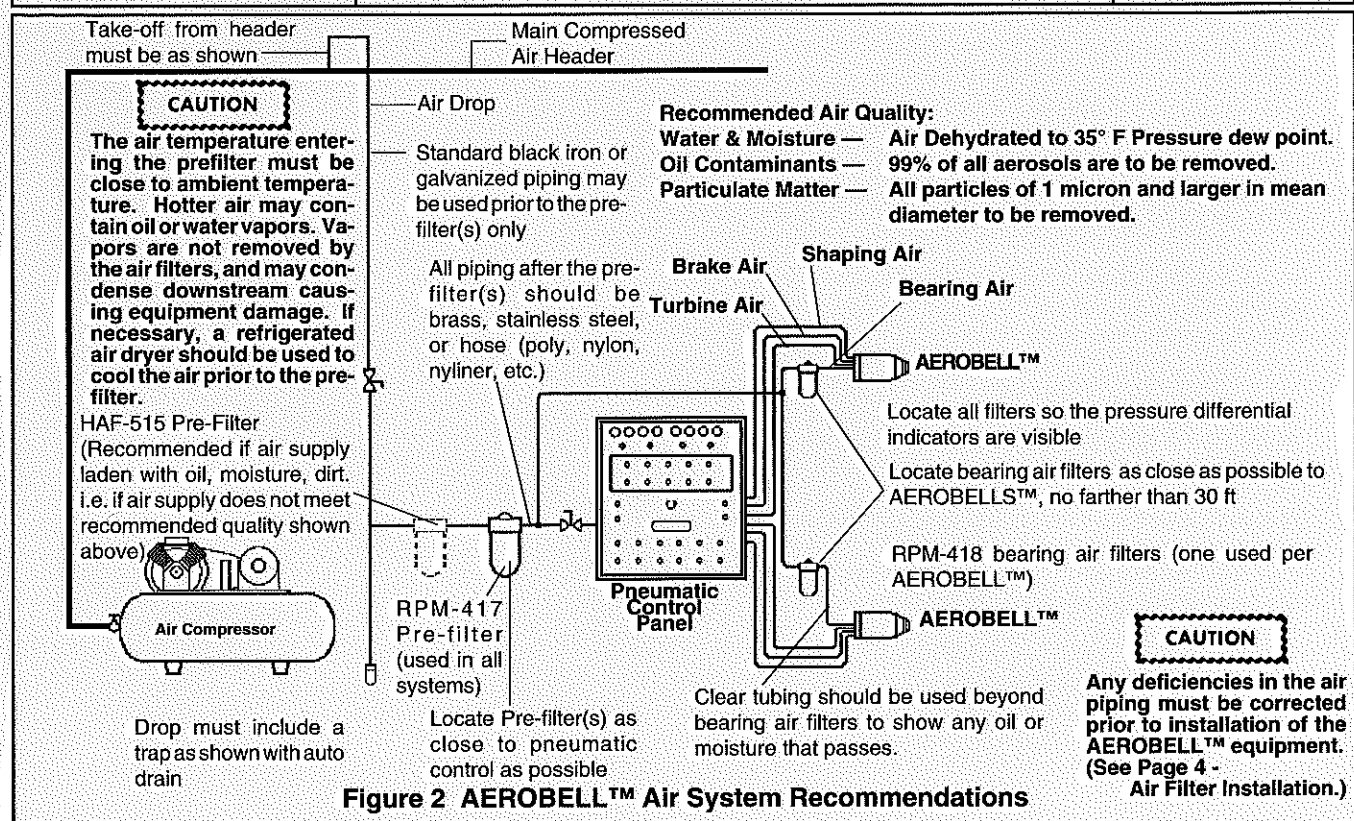

**Figure 2 AEROBELL™ Air System Recommendations**

**INSTALLATION****WARNING**

**Risk of arcing/fire hazard. The AEROBELL™ & AEROBELL™ PLUS must be located a safe distance from the object to be sprayed, as well as all other grounded objects. The safe distance is at least 1 inch per 10 KV of electrostatic voltage. Example: if the AEROBELL™ is used with 100 KV applied voltage, it must be at least 10 inches from the object to prevent arcing.**

The AEROBELL™ & AEROBELL™ PLUS shipping container includes the basic atomizer assembly with bell and manifold. Also required with the system are 2 (or more) RPM-419 wrenches (ordered separately). The RPM-419 wrenches are used to remove the shaping air cap and air ring, and the bell (wrenches not required during installation as the cap, ring and bell are mounted in place). The optional CCV color change valve assemblies are ordered and shipped separately.

Mount the AEROBELL™ or AEROBELL™ PLUS **securely** to a stationary or reciprocating fixture with the 3/4" dia. stud provided.

**Air Filter Installation**—The following guidelines **must** be observed when installing air filters for the AEROBELL™ or AEROBELL™ PLUS system: See Figure 2 for additional information.

- a). Use only recommended **pre-filters** and **bearing air filters** as shown in Chart 6. Additional system air filtration (i.e. refrigerated air dryer) may also be used if desired.
- b). Use one **bearing air filter** per AEROBELL™ or AEROBELL™ PLUS.
- c). Mount the **bearing air filter** as close as possible to the AEROBELL™ or AEROBELL™ PLUS (**do not mount** further than 30 ft. away).
- d). Where possible the **pre-filter** (s) and **bearing air filter** (s) should be mounted where they can be easily seen, so the user will see when maintenance is required.
- e). Standard black iron or galvanized piping may be used **prior** to the HAF-515 or RPM-417 pre-filters only. All piping after the pre-filter should be brass, stainless steel, aluminum, or hose (poly, nylon, nyloner, etc.).
- f). Do **not** use teflon tape, pipe dope, or other thread sealant downstream of the **bearing air filter**. Loose flakes of teflon tape or other sealant can break loose and plug the very fine air holes in the turbine bearings.

- g). Use clear see-through air tubing between the **bearing air filter** and bearing air fitting to clearly indicate to the user if oil or moisture contamination is getting past the filter.
- h). If air heaters are used in the system (to eliminate excessively humid conditions), and the heated air will exceed 120°F, the heaters must be located after all filters to prevent damage to the filter media.

**Air & Fluid Connections****WARNING**

**Arcing/fire hazard exists if ungrounded metal connections (air or fluid) are used in the spray area. Use plastic non-conductive connections, or insure metal connections are at ground potential.**

See Figure 5 for rear views of the AEROBELL™ & AEROBELL™ PLUS manifolds. Refer to this figure for proper location of connections.

Refer to Figures 6, 7, 8 and 9 for the optional color valve assemblies. Refer to the color valve assembly arrangement appropriate for the system.



# AEROBELL™ & AEROBELL PLUS™

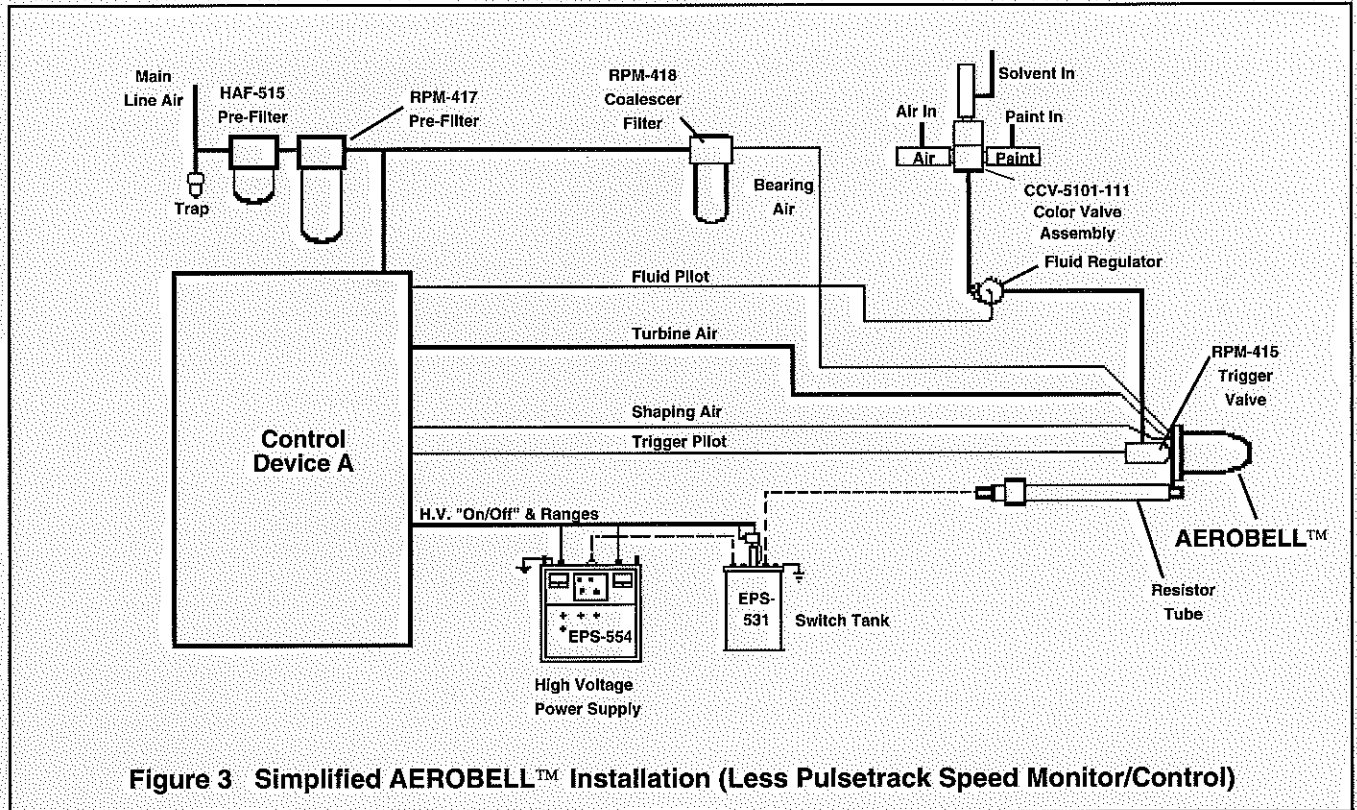

Figure 3 Simplified AEROBELL™ Installation (Less Pulstrack Speed Monitor/Control)

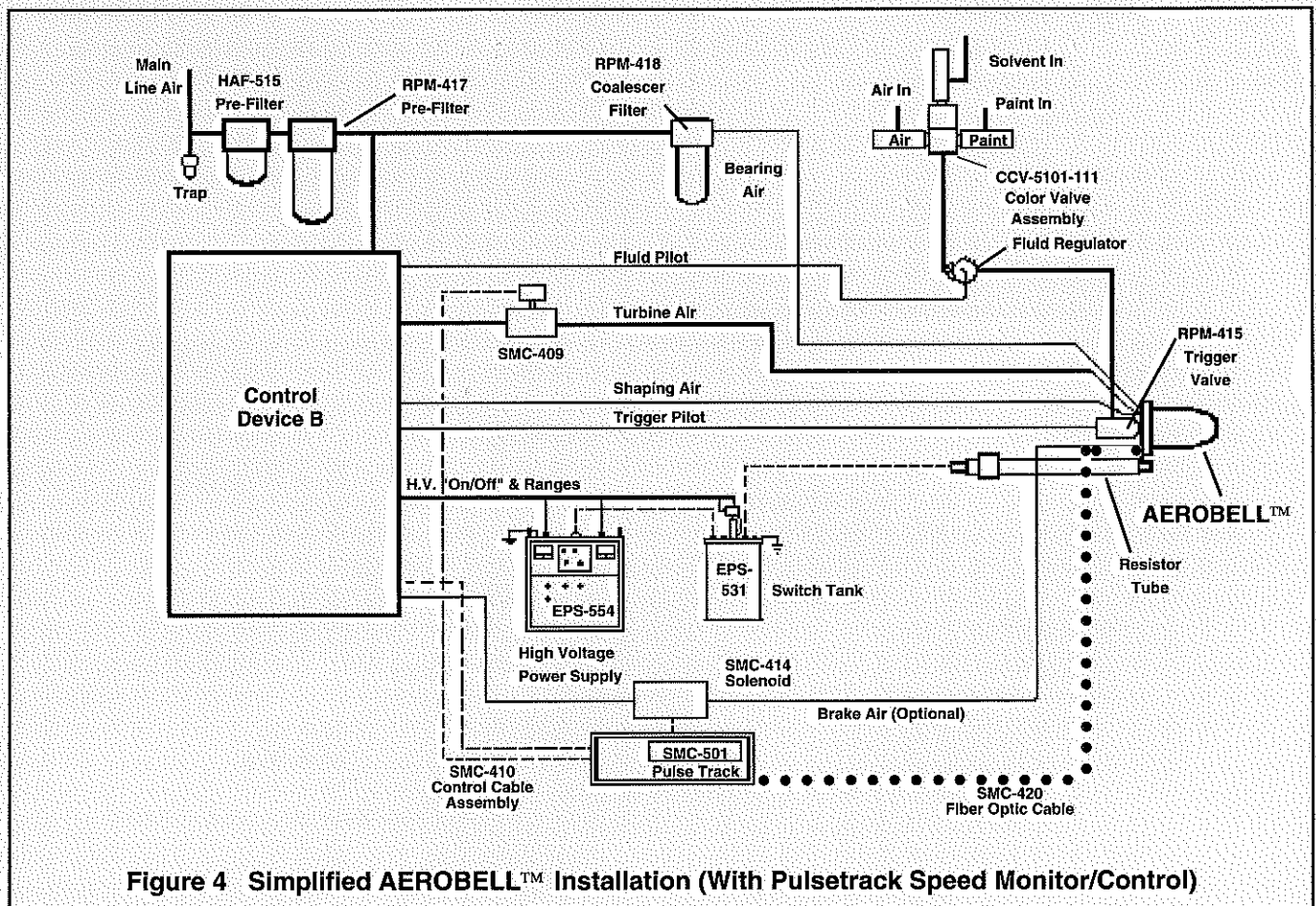
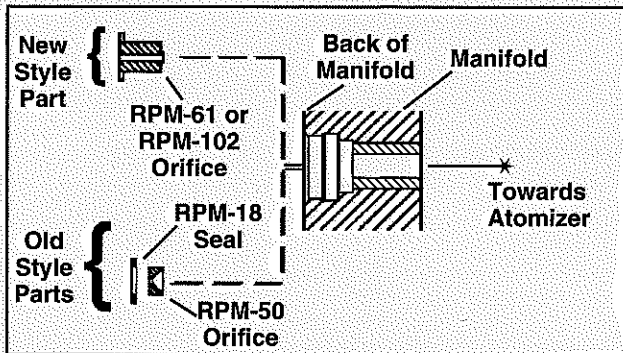
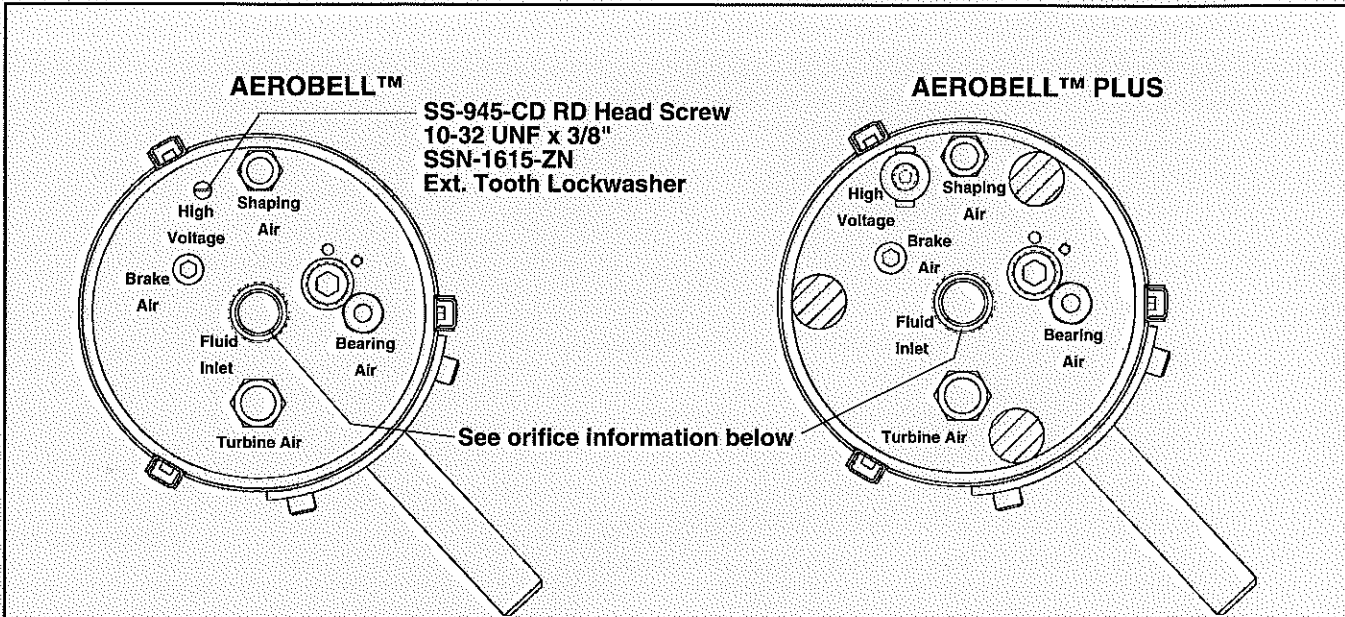

Figure 4 Simplified AEROBELL™ Installation (With Pulstrack Speed Monitor/Control)

# AEROBELL™ & AEROBELL PLUS™



The old AEROBELL™ Assembly parts numbers (i.e., RPM-501, -502) included an RPM-50 orifice (0.032" ID). This was used with RPM-18 seal in conjunction with RPM-416, -408, -409, -426, and -427 valve assemblies. The new AEROBELL™ Assemblies include RPM-61 orifice (0.032" ID.) When using RPM-61, the RPM-18 seal is not used. When using RPM-415, one valve assembly, do not use the RPM-61-orifice. RPM-61 orifice is supplied with AEROBELL™. RPM-102 orifice (.045" I.D.) provides less restriction than RPM-61. RPM-102 is optional and must be ordered separately.

**Connector Information:**

- Bearing Air - SSP-6079, Straight Connector, 1/4" O.D. Tube x 1/4 NPT Th'd
- Turbine Air - SSP-6071, Straight Connector, 1/2" O.D. Tube x 3/8 NPT Th'd
- Shaping Air - SSP-6066, Straight Connector, 3/8" O.D. Tube x 1/4 NPT Th'd
- Brake Air - SSP-6066, Straight Connector, 3/8" O.D. Tube x 1/4 NPT Th'd
- Fluid Intet - RPM-415 Valve Ass'y, RPM-416 2 Valve Ass'y, RPM-408 2 Valve Ass'y or RPM-409 3 Valve Ass'y is required for unit operation. (Not shown. Shipped and sold separately.)

**Figure 5 AEROBELL™ & AEROBELL™ PLUS Manifolds — Air/Fluid Connections**

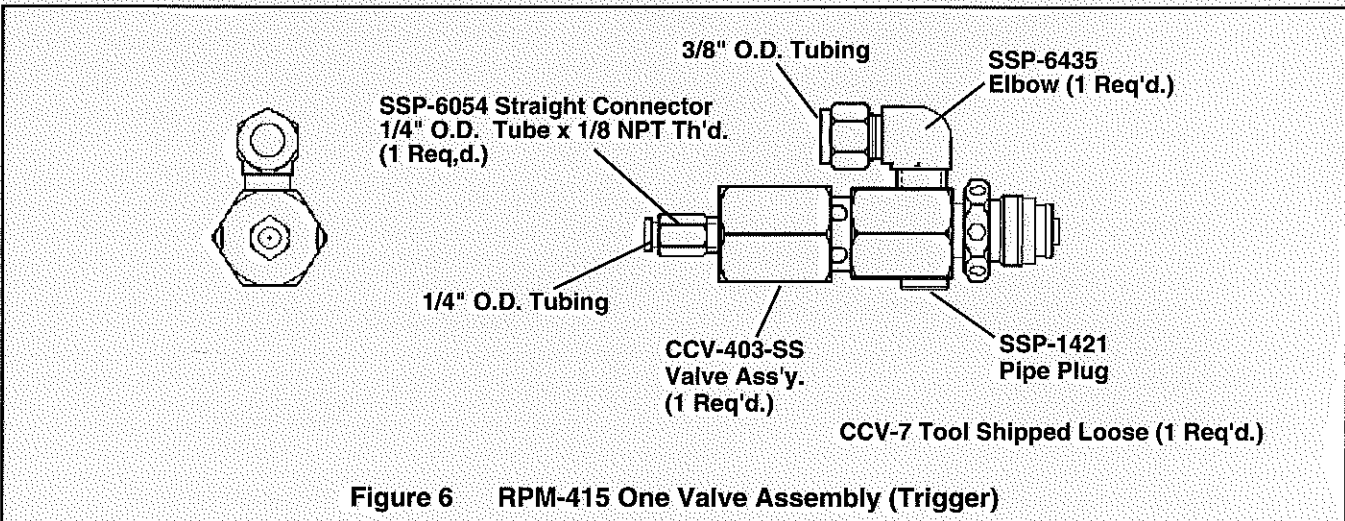

**Figure 6 RPM-415 One Valve Assembly (Trigger)**

# AEROBELL™ & AEROBELL PLUS™

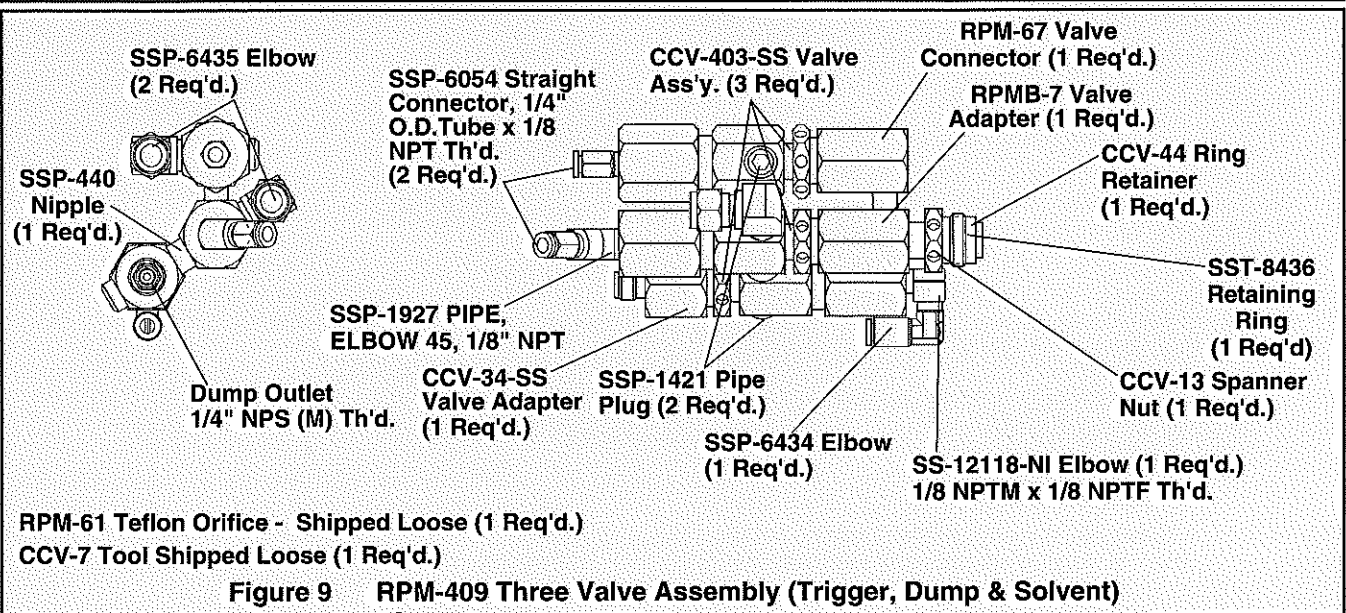
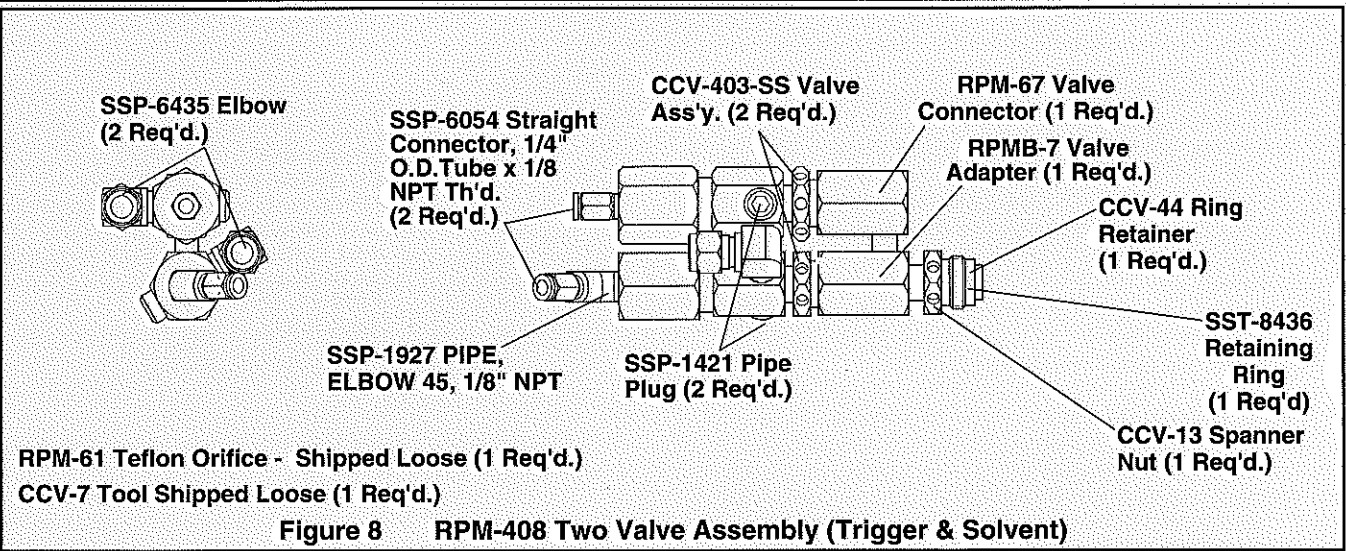
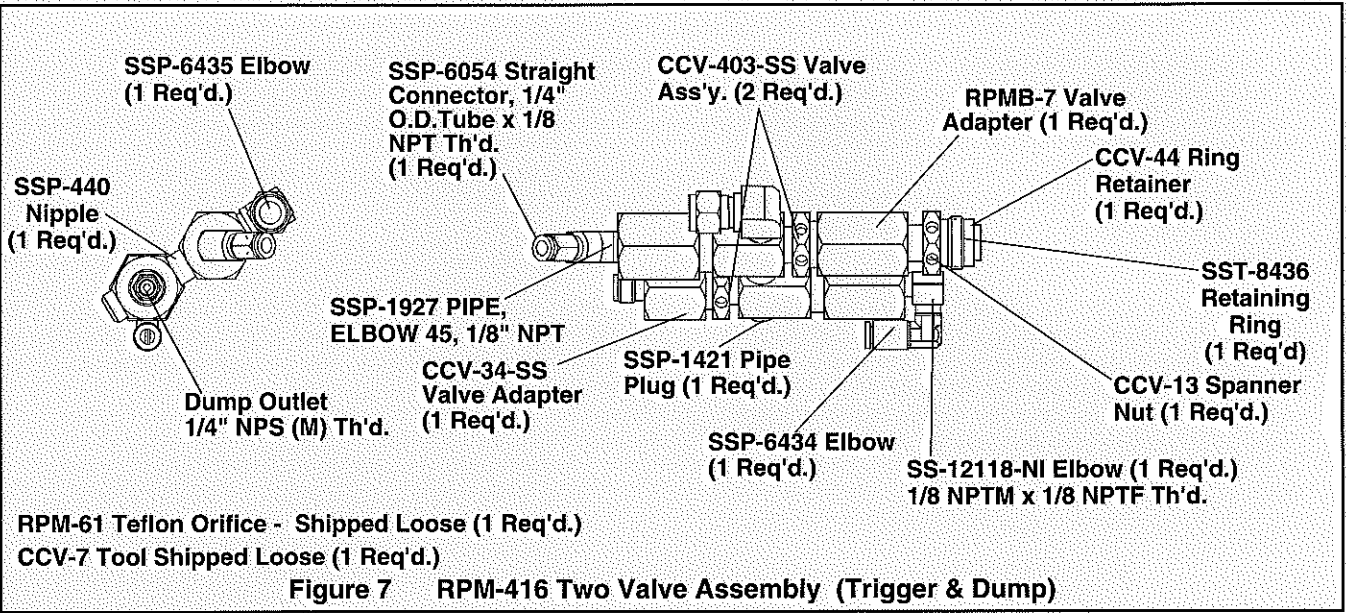

**AEROBELL™ & AEROBELL PLUS™**

Install color valve assembly into rear of manifold as follows:

- a) If RPM-415 one valve assembly is used, screw the spanner nut of the valve into the inlet of the manifold (hand tight).
- b) If RPM-416, -408, or -409 valve assemblies are used, install RPM-61 orifice into manifold (See Figure 5.)
- c) It is recommended to leave the valve assembly hand tight until all air/fluid connections are made to the rear of the manifold and to the valves before tightening the spanner nut, in case the valve assembly must be rotated for clearance purposes. After all connections are made, tighten spanner nut with CCV-7 spanner tool (132-156 in. lbs. torque—do not over tighten, seal damage may occur). (Spanner tool provided with each valve assembly.)

**CAUTION**

**Do not use teflon tape or pipe dope on any air fittings beyond the final air filter for BEARING AIR. The tape or dope may break free and cause plugging of the turbine air bearings, and result in turbine failure.**

**Bearing Air**—Using 1/4" O.D. x 1/16" wall tubing (clear see-through), connect a properly filtered air source to the "BEARING AIR" fitting on the manifold. It is recommended to use clear (see through) tubing for bearing air so that any contamination that gets past the final bearing air filter will be apparent. See Figure 3. Also refer to the above Caution.

Under the "Operation" section which follows, there is a Caution regarding bearing damage if the turbine is run while bearing air is off. Since the turbine must not be operated without first turning on bearing air, it is required to provide some means of assuring the presence of bearing air before turning the turbine "On". One method is by interlocking the turbine drive air to the bearing air (i.e. with an air piloted valve).

**CAUTION**

**Provisions should also be made to assure bearing air remains on during the coast down period when turbine air is turned off. (See "Specifications" on page 1.)**

**Shaping Air**—Using 3/8" O.D. x 1/16" wall tubing, connect shaping air source to the "SHAPING AIR" fitting on the manifold. See Figure 3.

**Brake Air**—Using 3/8" O.D. x 1/16" wall tubing, connect brake air source to the "BRAKE AIR" fitting on the manifold. See Figure 5.

**Note**

**The brake air fitting is plugged at the factory. If the brake air feature is not used, do not remove the plug. The plug is used to keep foreign contamination out of the unit, and prevent air leakage.**

**Turbine Air**—Using 1/2" O.D. x 1/16" wall tubing, connect turbine air source to the "TURBINE AIR" fitting on the manifold. See Figure 5.

**Paint/Solvent/Dump Trigger Air**—Using 1/4" x 1/16" wall tubing, connect to piston end of color valves as appropriate. See Figures 6 thru 9 as appropriate.

### FLUID CONNECTIONS

The fluid inlet(s) (outlet for dump valve) used on the color valve(s) will accept 3/8" O.D. tubing. See Figure 6 thru 9 as appropriate for hookup information. See note below.

**Note**

If the coating material used is heated, check the max. rated temperature for the fluid tubing to be used. Polyethylene tubing (H-2338 & H-2339) is rated for a max. of 80°F (27°C). Nylon tubing (H-2340 & H-2341) is rated for 200°F (95°C) max.

### HIGH VOLTAGE

Attach high voltage to #10-32 screw located on rear of manifold - Aerobell™ only. See Figure 5. If using an EPS-581 resistor cable assembly or other method of attaching high voltage, the connection may be made at any appropriate location on the manifold or mounting stud hardware. The Aerobell Plus™ uses a banana plug assembly connection at this point.

### AEROBELL™ & AEROBELL™ PLUS SYSTEM INTERLOCK SUGGESTIONS

The following system interlocks are recommended to prevent equipment damage;

- a) Bearing air on at all times. Only way to shut bearing air off is to shut off main air to pneumatic control cabinet. When turbine air is turned off, there is an approx. 2 minute "coast down" period before turbine stops spinning. Provisions should be made to assure the user waits at least 3 minutes before shutting main air off.
- b) Can't spray unless turbine is spinning (with bypass for fluid flow checks).
- c) If bearing air falls below 60 PSI at the turbine, turbine air is shut off and an indicator on the pneumatic control cabinet alerts the user.
- d) The pneumatics must prevent the turbine from exceeding the max. rated speed of 60,000 RPM. A 60 PSI max. turbine air regulator should be used.
- e) For AEROBELLS™ spraying in vertical - facing up position, provide a device to flip atomizer into horizontal plane during color change, flushing, and maintenance to reduce chances of paint or solvent running down into the turbine.

# AEROBELL™ & AEROBELL PLUS™

## OPERATION

### WARNING

Operators must be fully trained in safe operation of electrostatic equipment. Operators must read all instructions and safety precautions prior to using this equipment (Ref. NFPA-33, Ch 15.)

## TURBINE SPEED

The speed of the turbine is determined by the air inlet pressure. See Chart 5 "TURBINE AIR PRESSURE/RPM/SCFM," under Air Filtration Requirements section for more information. The desired speed will depend upon the type of coating material and various application requirements.

### CAUTION

**Excessive speed will cause air turbine damage. Do not exceed the maximum rated speed of 60,000 RPM.**

Turbine speed may be controlled by use of optional Pulsetrack™ speed monitor and control. Contact your DeVilbiss Ransburg representative for more information on this optional equipment.

## BEARING AIR

### CAUTION

**Air bearing air must be on whenever the turbine is operated. If not, severe bearing damage will occur. It is recommended to leave bearing air on at all times. During maintenance or disassembly, turbine air must be off for at least 3 minutes before shutting off bearing air or main line air.**

Bearing damage (and subsequent turbine failure) caused by running the turbine without bearing air will not be covered under DeVilbiss Ransburg warranty.

When turning the turbine on, bearing air must be present. Likewise, bearing air must remain on when the turbine air is turned off until the turbine stops spinning. Never turn off bearing air to cause the turbine to stop spinning. Brake air can be used to slow the turbine (see next section on BRAKE AIR), wait for the turbine to stop spinning before turning bearing air off.

### CAUTION

**Operating the turbine with bearing air pressure below 60 PSI (measured at turbine inlet) may cause bearing damage.**

The nominal bearing air pressure is 80 PSI, 60 PSI minimum, 100 PSI maximum. Under no circumstances should the turbine be operated with less than 60 PSI bearing air pressure.

## BRAKE AIR

Brake air is used to slow the turbine speed. It is advantageous for short color change cycle times, and may be used for stopping the turbine. Use of the brake involves (1) turning off turbine drive air, and then (2) turning the brake air on for a short duration. For example, the air brake will reduce the turbine speed as shown in Chart 7.

### Chart 7

#### Braking Time (at 90 PSI Brake Air Pressure)

To Brake From (RPM)	Seconds (Approx.)
60,000 to 40,000	3.7
60,000 to 20,000	7.5
60,000 to 0	12.9
40,000 to 20,000	4.0
40,000 to 0	9.0

## ELECTROSTATIC VOLTAGE

Depending upon the power supply model used, the maximum output voltage of the power supply can vary. The actual voltage setting will depend upon various coating application requirements. The level of voltage applied to the AEROBELL™ plays an important role with regard to pattern size, efficiency (wrap), penetration into cavity areas, and target distance. The Aerobell Plus™ System has a maximum output of 100 KV.

## SHAPING AIR

Shaping air is used to shape the spray pattern. The lower the pressure, the wider the pattern and conversely, higher pressures result in narrower patterns. Shaping air does not help atomize the material, but does assist in the penetration of atomized particles into cavity areas. Shaping air should be kept at a minimum consistent with coating requirements. Excessive shaping air will cause some atomized particles to blow by the target not allowing full "wrap", or paint particles to bounce back onto the atomizer.

## TARGET DISTANCE

The distance from the AEROBELL™ atomizer to target affects the spray application. For instance, closer distances give a smaller spray pattern and greater efficiency. Increasing the distance will give a larger pattern and possibly reduce efficiency. If the distance is too great, material may "wrap back" on the AEROBELL™. However, coming too close may cause arcing. See Warning below.

### WARNING

**Risk of arcing/fire hazard. The AEROBELL™ must be located a safe distance from the object to be sprayed, as well as all other grounded objects. The safe distance is at least 1 inch per 10 KV of electrostatic voltage. Example: if the AEROBELL™ is used with 100 KV applied voltage, it must be at least 10 inches from the object to prevent arcing.**

**MATERIAL CONDUCTIVITY**

The AEROBELL™ can be used with a full range of conductive coating materials. With coatings having higher conductivity it may be necessary to isolate the material supply tank and hoses from ground. If there is any question as to the suitability of spraying a material with the AEROBELL™, contact your DeVilbiss Ransburg distributor or representative. See Warning below.

**WARNING**

**Electrical discharge can cause fire or explosion. If arcing occurs when a specific coating material is used, turn the system off immediately and notify your coating supplier. Do not restart system until proper adjustments are made to your coating material.**

**PREVENTATIVE MAINTENANCE****WARNING**

**Electrical shock/arcing and fire hazards can exist during maintenance. The high voltage must be turned off before entering the spray area and performing any maintenance procedures. Spray booth exhaust fans(s) should remain on while cleaning the equipment with solvents.**

**Never touch the atomizer bell while it is spinning. The front edge can easily cut into human skin. Make sure the atomizer bell has stopped spinning before attempting to touch it. Wait at least three minutes after turbine drive air is off before touching the bell.**

In addition to the above Warning which relates to potential safety hazards, the following information under **Caution** must be observed to prevent damage to the equipment.

**CAUTION**

1. **Do not immerse the AEROBELL™ turbine in solvent or other liquids. Turbine components will be damaged.**
2. **Bearing air must be on during all cleaning procedures.**
3. **If the AEROBELL™ is sprayed off with a solvent gun for cleaning, the turbine should be turned on, as well as shaping air (high voltage off). Air exhausting from the turbine and shaping air form a curtain around the back edge of the bell, and help prevent solvent from getting into the cavity behind the bell. Do not direct the solvent spray directly at the opening behind the edge of the bell, as this may allow solvent to be forced into the turbine.**

**Cleaning Procedures**

The precise sequence of flushing the system of paint will vary according to the type of color valve arrangement used, and other automatic features built into the system. But follow these basic procedures when cleaning:

1. Verify high voltage is off.
2. With the bearing air and turbine air on, flush paint out of material lines with solvent. Flushing should be done before any break in production. If the AEROBELL™ is mounted vertical-facing up, rotate to horizontal plane before flushing or cleaning.
3. Flushing should be done with the atomizer bell installed. The bell includes a self cleaning feature, and the bell will normally be fully cleaned with flushing. However, if there is any remaining paint build up on any areas of the bell after flushing, the bell should be removed for hand cleaning.
4. Clean the bell by soaking in an appropriate solvent as long as necessary to loosen paint. Use a soft bristle brush dipped in solvent to remove paint. Make sure all signs of paint are removed. See Caution below. Rinse and dry bell.
5. Before re-installing the bell onto the shaft, check the tapered mating surfaces of the turbine shaft and bell for any paint residue. Clean any residue. See Caution below.

**CAUTION**

**Using an atomizer bell with paint build up will cause a bell imbalance. An imbalanced bell may cause bearing damage and turbine failure. Also, any paint residue caught between the tapered surfaces can prevent the bell from seating properly and result in an imbalanced condition.**

6. Clean the exterior of the AEROBELL™ as follows (see Warning first):

**WARNING**

**To reduce the risk of fire or explosion, OSHA and NFPA-33 require that solvents used for exterior cleaning be non-flammable (flash points higher than 100°F/37.8°C). Also, since electrostatic equipment is involved, these solvents should also be non-polar. Examples of non-flammable, non-polar solvents for wipe down are: amyl acetate, methyl amyl acetate, high flash naphtha and mineral spirits.**

- a) If spraying the AEROBELL™ with a solvent cleaning gun, do not direct the spray at the opening behind the atomizer bell. Turbine air and shaping air should be on (High Voltage Off).

# AEROBELL™ & AEROBELL PLUS™

- b). If using a rag to hand wipe the AEROBELL™, turbine air should be off, but leave shaping air on. Be careful not to drip solvent into the opening behind the bell. (See step #1.)
  - c). Do not use conductive solvents such as MEK to clean the AEROBELL™.
7. Do not reuse an atomizer bell that shows signs of damage such as nicks, heavy scratches, dents, or excessive wear.

**Vibration Noise**—If the AEROBELL™ is vibrating or making an unusually loud noise, it usually means there is an imbalance situation. The atomizer bell may have dried paint on it, or the bell may be physically damaged, or there may be paint trapped between the bell and shaft preventing the bell from properly seating. If any of these conditions exist, they **must** be corrected. Excessive imbalance caused by one of these conditions may result in bearing damage and turbine failure. Warranty **does not** cover failure caused by imbalanced loading conditions.

To determine if the bell is dirty or damaged, remove the bell and turn the turbine on. If the noise is eliminated, the bell is the problem. If the noise continues, the turbine may be damaged and should be inspected. Do **not** continue to operate a noisy turbine.

## AIR FILTERS — ELEMENT REPLACEMENT



Introducing air which contains oil, moisture and dirt may cause wear and damage to the bearings. It is the user's responsibility to monitor the quality of air and to replace the filter elements as often as necessary. Turbine failure caused by poor air quality will not be covered under warranty.

**Chart 8**  
Replacement Elements

DeVilbiss Part No.	Qty. Elements Per Carton	Used On
HAF-5	1	HAF-515 Pre-Filter
RPM-32	4	RPM-417 Pre-Filter
RPM-33	8	RPM-418 Bearing Air Filter

DeVilbiss Ransburg designed and installed AEROBELL™ systems include a pre-filter(s) which filters all air to the AEROBELL™, and a final filter for bearing air only. All filters contain elements that must be replaced on a regular basis to assure clean air. RPM-417 and RPM-418 filters also contain an automatic drain and pressure differential indicator.

The pressure differential indicator provides a visual indicator that pops up (becomes more visible) as the filter element becomes plugged.

Replace the filter elements when the visual indicator

becomes visible, don't wait until it pops up fully. As the elements become plugged, their efficiency drops. The frequency of filter element change will depend upon the quality of the plant air. But it is recommended that all elements be replaced at least every 4 to 6 months.

In plants where heavy amounts of oil and moisture vapor are present in the air lines, a refrigerated air dryer may be necessary.

The AEROBELL™ is designed to give dependable service and extended life. One of the most important factors in realizing long life is the quality of air. It is therefore essential for the user to closely monitor the quality of their air and to properly maintain the air filters by replacing the filter elements as often as necessary. (Replace elements at least every 4-6 months or more often.)

## FELT MUFFLER

Replace the felt muffler (RPM-35) once per year.

## DISASSEMBLY PROCEDURES

### ATOMIZER BELL REMOVAL

1. Remove RPM-4 shaping air cap from shroud using RPM-419 wrench turning CCW. See Figure 10. Note the RPM-5 shaping air ring will come off with the RPM-4 shaping air cap.



Figure 10

2. To remove atomizer bell, place RPM-419 wrench over flats of shaft to lock shaft. Unscrew atomizer bell by hand turning CCW. See Figure 11.



Figure 11

3. If the atomizer is tight and can't be removed by hand, use the second RPM-419 wrench to place over the wrench flats of the atomizer bell.
4. Refer to the Preventive Maintenance section for important information about atomizer bell cleanliness. Do not install a dirty or damaged bell onto the AEROBELL™.

#### RPM-4 SHAPING AIR CAP/ RPM-5 SHAPING AIR RING DISASSEMBLY

1. Separate RPM-4 and RPM-5 by using two RPM-419 wrenches. Hold one stationary while turning the other CCW. See Figure 12. Note it is only necessary to separate these parts if replacing one, or for thorough cleaning.

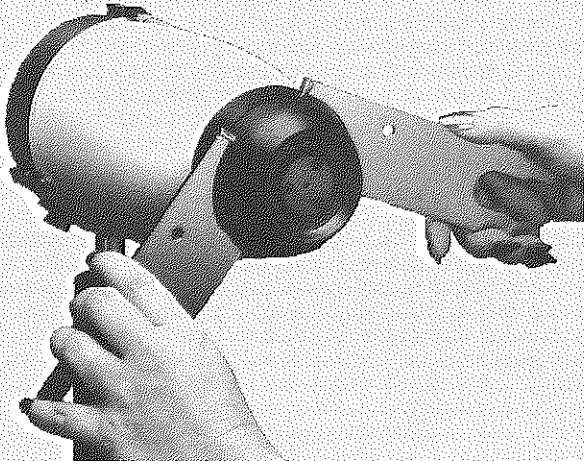

Figure 12

#### ATOMIZER BELL REASSEMBLY

1. Before reassembling the atomizer bell, insure the tapers of the shaft and bell which mate are totally clean, as well as the shaft and bell threads.
2. Place RPM-419 wrench over wrench flats of shaft to lock the shaft. See Figure 11.
3. Screw atomizer bell onto shaft in CW direction. **(Hand tighten only)**. See Figure 11.
4. Reinstall RPM-4 shaping air cap and RPM-5 shaping air ring into shroud. Note when screwing RPM-4 in place, it will become tight after approx. 2 -1/2 turns. At this point, use the RPM-419 wrench to tighten further. The RPM-4 will break free and become loose again and can then be tightened down fully until it bottoms against the shroud.

#### QUICK CHANGE AEROBELL™ REMOVAL

**CAUTION**

Be sure to carefully hold the shroud while unlatching the three latch buttons that secure the Quick Change Assembly into the manifold. The Quick Change Assembly weighs approx. 7 lbs. and may be dropped and damaged if not properly supported.

1. Prior to removing the Quick Change Assembly, flush the paint feed line and bell with solvents. If flushing is not possible and paint is in the atomizer feed tube, place a rag over the bell end of the atomizer and proceed to step 2.
2. Unlatch three draw latches while carefully supporting the shroud. See Figure 13.



Figure 13

3. Pull Quick Change rotary atomizer away from the manifold. **Do not** allow any paint to drip from the manifold into the air ports on the back of the air turbine.

#### QUICK CHANGE AEROBELL ROTARY ATOMIZER DISASSEMBLY

1. Remove RPM-4 shaping air cap, RPM-5 shaping air ring, and atomizer bell from shroud — refer to "Atomizer Bell Removal" in this section.
2. Remove shroud by removing the three latch button assemblies with a 1/16" allen screwdriver. Shroud can then be pulled forward. See Figure 14.

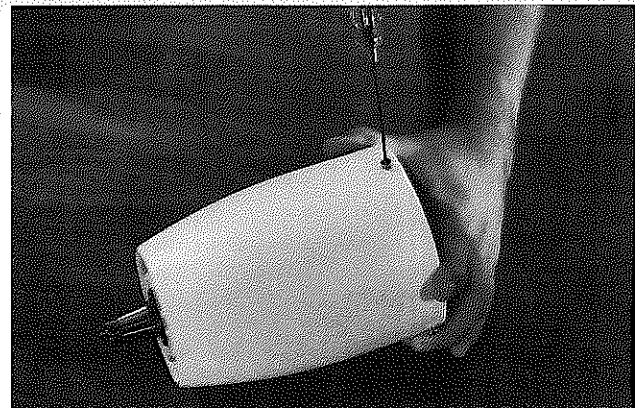

Figure 14



## AEROBELL™ Turbine Disassembly & Repair

**CAUTION**

Disassembly and repair of the turbine during warranty period is not allowed. See "Warranty" on page 19, and refer to SR-70-52-1 for details.

Disassembly and repair of the Turbine is covered in Service Reference SR-70-52-1 (latest issue). When returning the air bearing turbine to DeVilbiss Ransburg for repair, return the Quick Change Assembly atomizer or turbine only.

### QUICK CHANGE AEROBELL™ ROTARY ATOMIZER REASSEMBLY

1. Reassemble the shroud, atomizer bell, shaping air ring and cap onto the Quick Change Assembly by reversing the above instructions.
2. Before installing the Quick Change Assembly back into the manifold, check the condition of the four teflon-coated O-rings located on the four air fittings of the manifold. If any are damaged or missing, replace them (order KK-4459 O-ring Kit). See Figure 15.



**Figure 15**

3. Check the condition of the SSG-8128 Kalrez O-ring located on the fluid inlet on the rear of the turbine. Replace if damaged or missing. Lightly lubricate the SSG-8128 O-Ring with Vaseline.
4. Install the Quick Change Assembly into the manifold. Align properly (it is easiest to align the shaping air fitting which is furthest from the center line). Press the Quick Change Assembly straight forward as much as possible (don't force it on).
5. Latch the three latch button assemblies which will draw the Quick Change Assembly fully into place in the manifold.

# AEROBELL™ & AEROBELL PLUS™

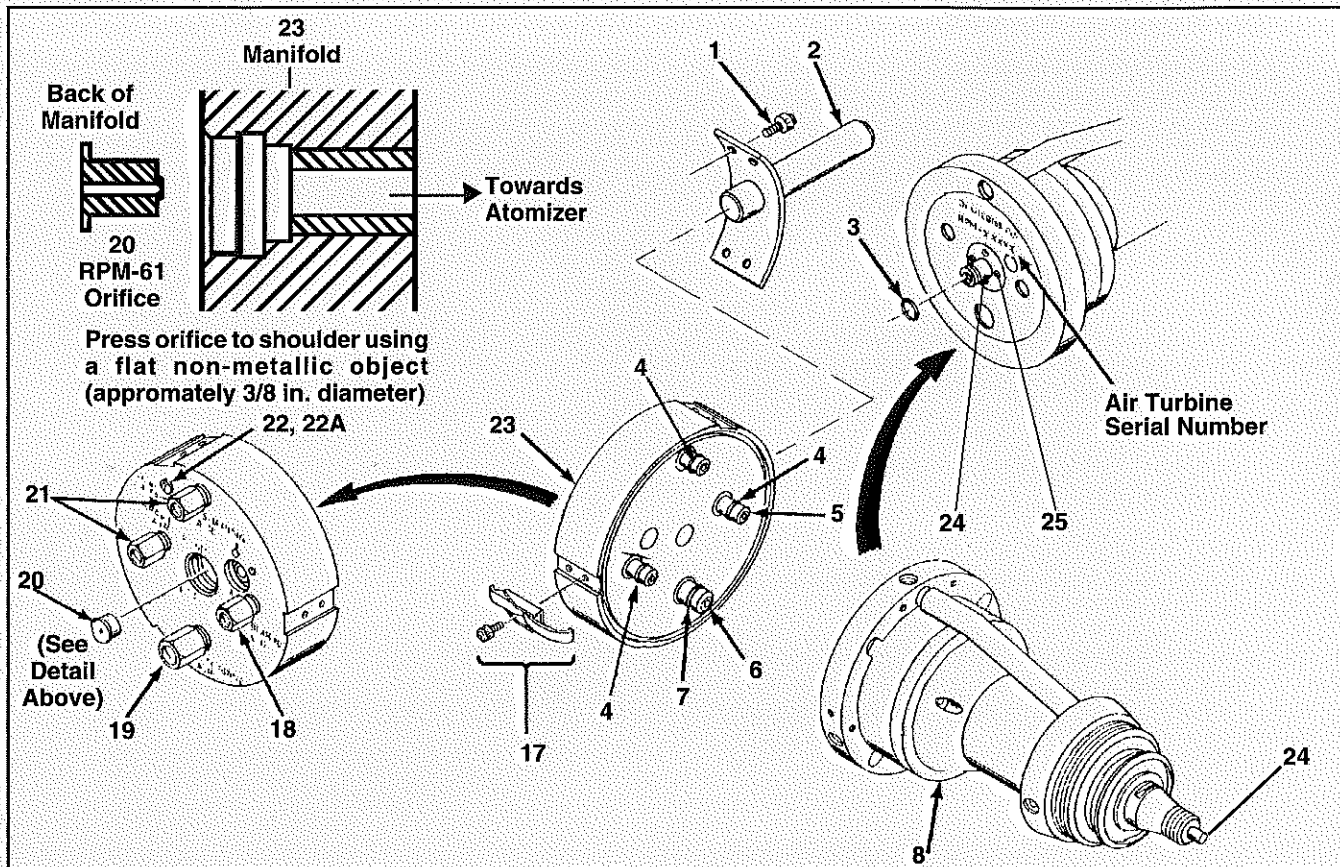

Figure 16 a Exploded View — Quick Change Rotary Atomizer

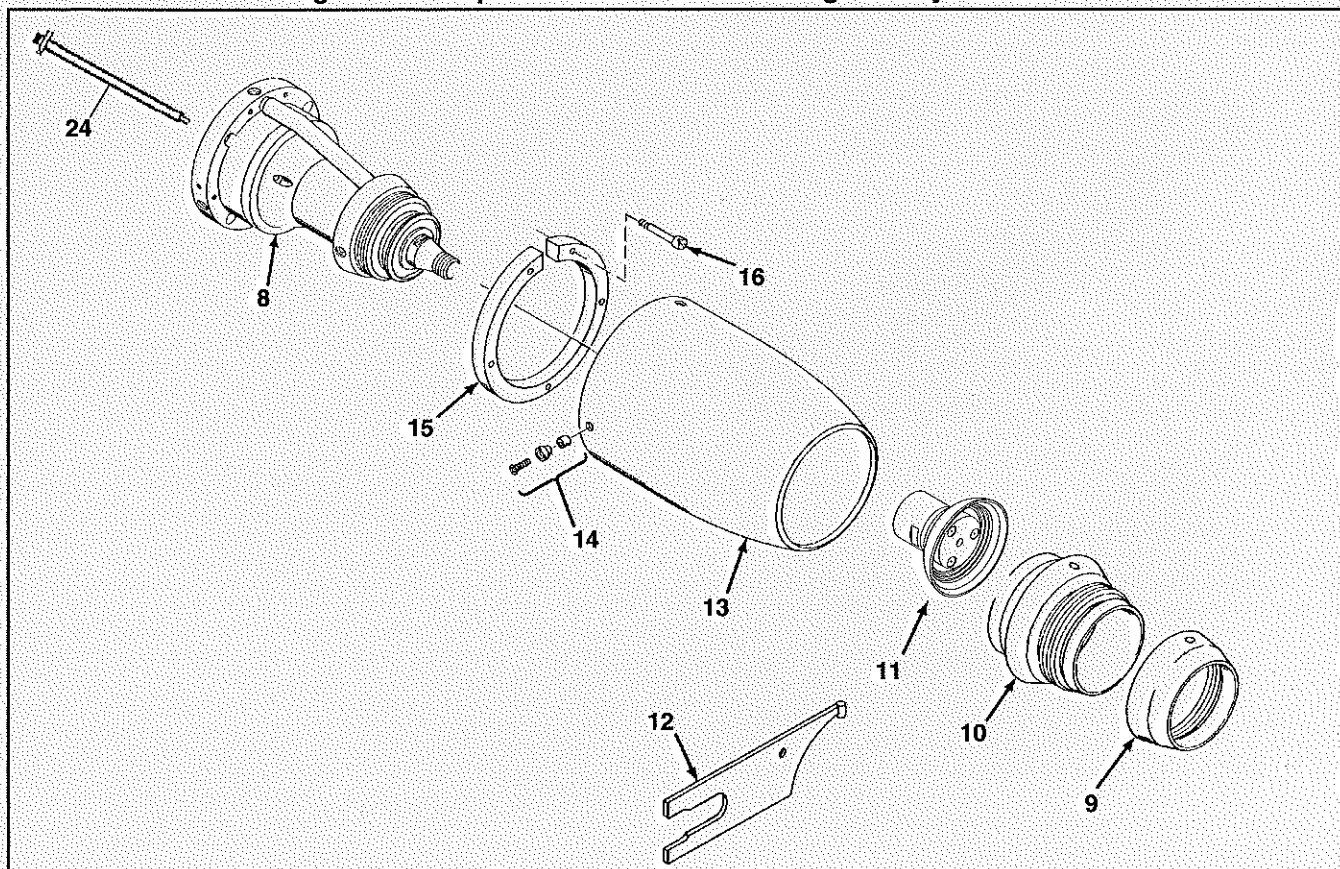

Figure 16 b Exploded View — Quick Change Rotary Atomizer

# AEROBELL™ & AEROBELL PLUS™

**PARTS LIST**

Ref. No.	Replacement Part No.	Description	Qty.
❖ —	—	Quick change rotary atomizer (see Chart 1) (Includes items 3, 8 through 11, 13 through 16, and 24.)	1
1	SS-7936-NI	Screw, Hex Socket, 1/4-20 x 5/8"	4
2	RPM-403	Stud Assembly	1
❖ 3	SSG-8128	"O" Ring, Kalrez®	1
❖ ⊕ 4	—	"O" Ring, teflon coated	3
❖ 5	RPM-12	Fitting, 0.360" diameter	3
❖ 6	RPM-13	Fitting, 0.550" diameter	1
❖ ⊕ 7	—	"O" Ring, teflon coated	1
8	RPM-406	Turbine Assy.	1
9	RPM-5	Shaping air ring (See Chart 2)	1
10	RPM-4	Shaping air cap (See Chart 2)	1
11	—	Atomizer Bell (See Chart 2)	—
12	RPM-419	Wrench	—
❖ 13	RPM-3	Shroud, Polythylene	1
❖ ▲ 13	RPM-66	Shroud, Aluminum	1
14	KK-4460	Latch button repair kit (Includes 3 spacers, latch buttons and hex socket screws)	3
❖ 15	RPM-35	Felt Muffler	1
16	SSF-503	Shoulder screw	5
17	KK-4458	Draw latch repair kit (includes KK-4460)	3
18	SSP-6079	Straight connector, 1/4 tube x 1/4 NPT	1
❖ 19	SSP-6071	Straight connector, 1/2 tube x 3/8 NPT	1
20	RPM-61	Orifice, .032" ID (See Figure 3)	1
21	SSP-6066	Straight connector, 3/8 tube x 1/4 NPT	2
22	SS-945-CD	Screw, round head, #10-32 x 3/8"	1
22A	SSN-1615-ZN	Lockwasher, external tooth	1
23	RPM-425	Manifold assembly (includes items 1, 2, 4 through 7, and 17 through 22A)	1
24	RPM-441	Fluid tube, .062" (1/16") ID	1
	RPM-440	Fluid tube, .093" (3/32") ID	1
	RPM-439	Fluid tube, .125" (1/8") ID	1
25	SSF-3137	Screw, Hex Socket, M3 x 8	4

⊕ KK-4459 Manifold "O" Ring kit includes the necessary quantities of items 4 and 7.

▲ **Two wrenches (or more) required with AEROBELL system. They must be ordered separately.**

® Kalrez is a registered trademark of DuPont.

❖ These parts should be kept on hand for service convenience.

For RPM Color Valve Assemblies — refer to figures 3 through 6 to identify the required service parts.

Note for CCV-403-SS color valve assemblies, there is a repair kit available — KK-4841 Color Valve Repair Kit. Refer to Service Instruction LN 9100-00 (latest edition) for complete service information.

## AEROBELL™ Turbine Maintenance & Repair Items

### Chart 9 Prepackaged Repair Kits

Kit Part No.	Description	
KK-4458	Draw Latch Repair Kit	(includes KK-4460)
KK-4459	O-ring Kit	(manifold & fluid tube)
KK-4460	Latch Button Repair Kit	
KK-4461	Turbine Repair Kit	(for on-site turbine repair)
KK-4462	Rotor Screw Kit	(for on-site turbine repair)
KK-4463	Turbine Screw Kit	(for on-site turbine repair)
KK-4841	Color Valve Repair Kit	
RPM-33	Bearing Air Filter Element Kit	(box of 8)
RPM-32	Pre-filter Element Kit	(box of 4)

## AEROBELL PLUS™ PARTS

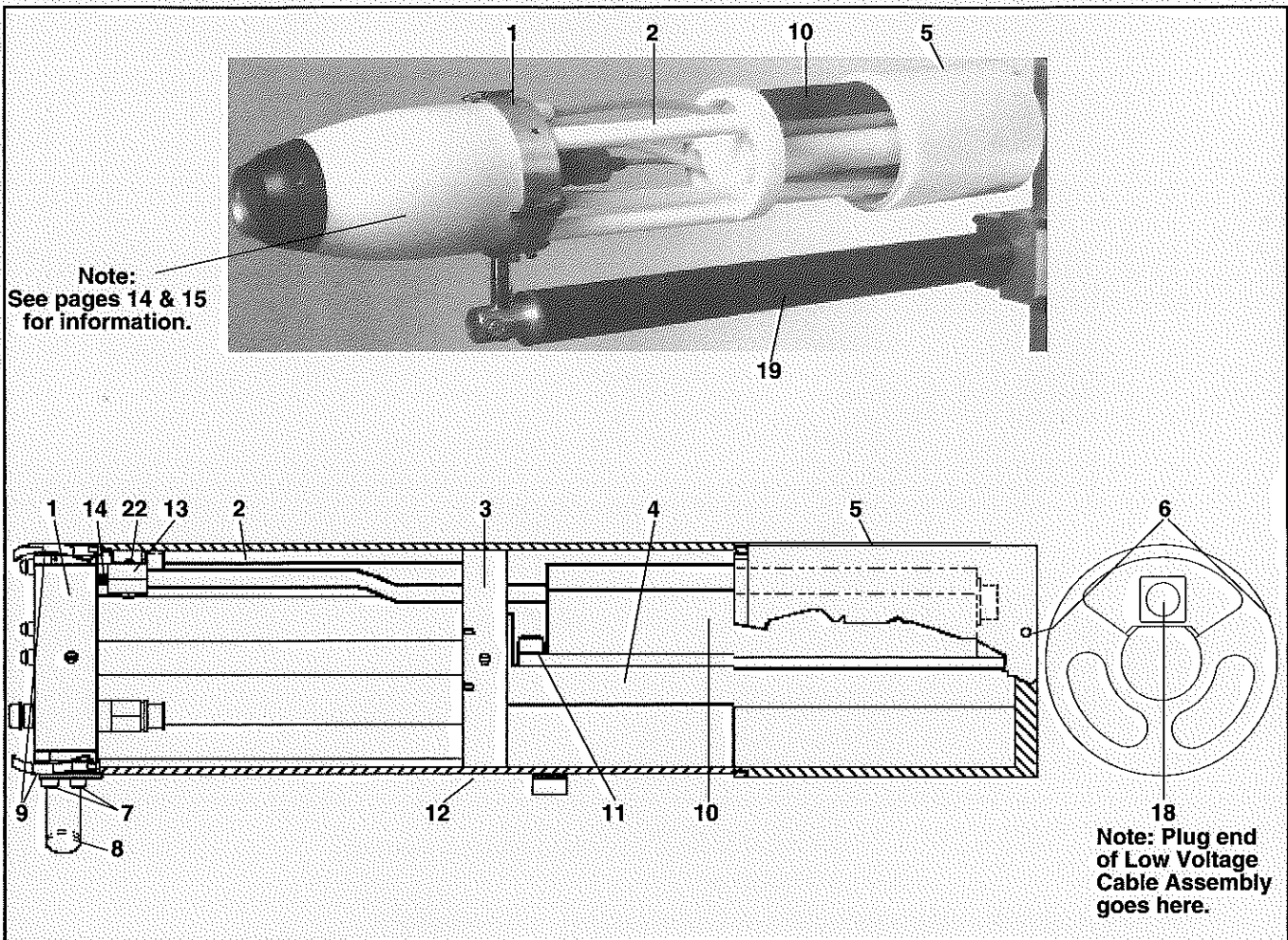

Figure 17 REAR SHROUD ASSEMBLY

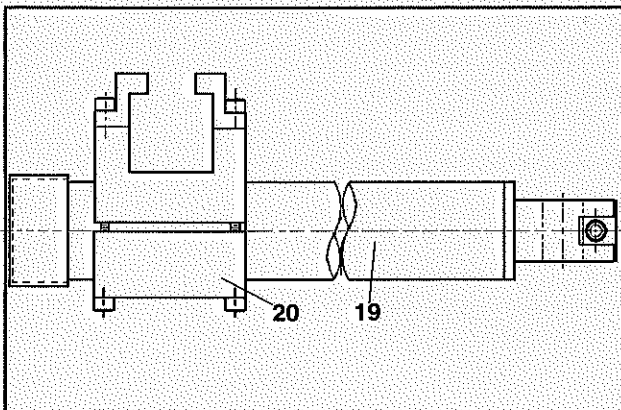

Figure 18 SUPPORT BRACKET & TUBE ASSEMBLY

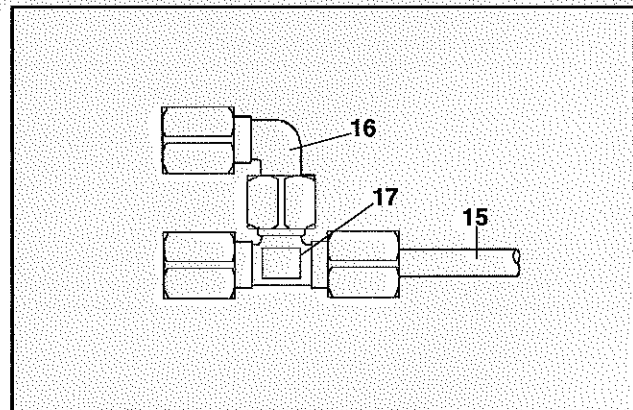
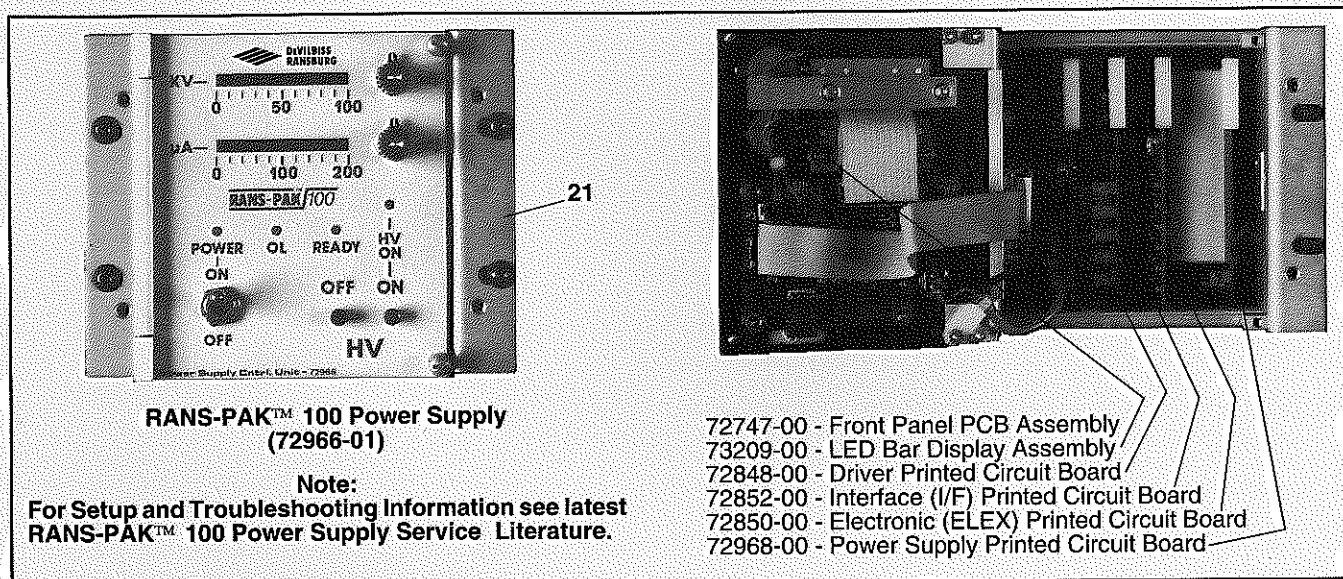

Figure 19 BEARING AIR INTERLOCK SUB-ASSEMBLY (shipped loose)

**AEROBELL PLUS™ PARTS Continued**



**RANS-PAK™ 100 Power Supply  
(72966-01)**

**Note:**  
For Setup and Troubleshooting Information see latest  
RANS-PAK™ 100 Power Supply Service Literature.

- 72747-00 - Front Panel PCB Assembly
- 73209-00 - LED Bar Display Assembly
- 72848-00 - Driver Printed Circuit Board
- 72852-00 - Interface (I/F) Printed Circuit Board
- 72850-00 - Electronic (ELEX) Printed Circuit Board
- 72968-00 - Power Supply Printed Circuit Board

**Figure 20 RANS-PAK™ 100 POWER SUPPLY**

**PARTS LIST**

Ref. No.	Replacement Part No.	Description	Qty.
1	LA0001	Manifold & Insert Assembly	1
2	LD0002	Support Rod	3
3	LD0003	Rear Manifold	1
4	LD0004	High Voltage Cascade Mount	1
5	LD0011	Shroud End Cap	1
6	LD0005	Set Screw	5
7	LS0001	Socket Head Cap Screw (1/4"-20 UNC x 3/8")	4
8	RPM-403	Stud Assembly	1
9	KK-4458	Draw latch repair kit (includes KK-4460)	3
10	74312-00	Cascade Assembly	1
11	LS0002	Socket Head Cap Screw 3/16"-16 UNC x 3/4"	3
12	RPM-424	Shroud & Latch Assembly	1
13	LD0055	Collar	1
14	LD0036	Banana Plug	1
15	H-2339	Polyethylene Tubing 1/4" O.D. x .175" I.D.	6"
16	SSP-6444	Female Elbow 1/4" O.D. x 1/8" NPTF	1
17	SSP-6813	Male Branch Tee 1/4" O.D. x 1/8" NPT	1
18	74313-00	Low Voltage Cable Assembly (Not shown)	1
19	RPM-435-1	Support Clamp & Tube Assembly	1
20	RPM-433	Mounting Bracket Assembly	1
21	72966-01	RANS-PAK™ 100 Power Supply	1
22	21643-411	Screw, #6-32 x 1/4 Pan Head	2

# **AEROBELL™ & AEROBELL PLUS™**



**NOTES:**

## WARRANTY FOR AEROBELL™ ROTARY ATOMIZER

The DeVilbiss Ransburg AEROBELL™ rotary atomizer is warranted to be free of defects in workmanship and material. The terms of this warranty, except as hereinafter provided, extend from one year from the date of first installation. This excludes equipment failures which are the result of misapplication, misuse, incorrect maintenance, or normal wear. If, after inspection by DeVilbiss Ransburg, defect is confirmed, we will at our option repair, replace, or issue credit, minus allowance for usage received.

## SPECIFIC AEROBELL™ AIR TURBINE WARRANTY

The air turbine only is warranted for 15,000 operating hours, or three years from the date of first installation, whichever occurs first. If, after inspection by DeVilbiss Ransburg, defect is confirmed, we will repair or replace the air turbine, free of charge, during the warranty period. The repaired air turbine (or replacement air turbine) will continue to be warranted for the remainder of the initial warranty period (from installation date). The warranty period for the air turbine does not begin again when a repair is completed under warranty. Air turbines repaired by DeVilbiss Ransburg after the warranty period will be warranted for 90 days from the date of shipment from the repair center.

### This Warranty Does NOT Cover:

1. AEROBELL™ or AEROBELL PLUS™ that has become inoperative because of:
  - a. Misuse — Particularly the flooding of the rotor area due to turning on the fluid before the turbine is up to speed.
  - b. Negligence.
  - c. Accidents — Collisions with external objects, fires, or similar occurrences.
  - d. Improper maintenance procedures.
  - e. Attempted customer repair of air turbine during warranty.
  - f. Failure to insure clean air to air bearing and turbine.
  - g. Operating turbine without air bearing air.
  - h. Operating turbine with less than the minimum specified air bearing pressure (60 PSI min., measured at turbine inlet).
  - i. Operating with imbalanced loads (heavy paint buildup on atomizer bell or shaft, or damaged atomizer bell).
  - j. Acts of God, flood, earthquake, or similar occurrence.

- K. AEROBELL™(s) or AEROBELL PLUS™ being operated by control systems not designed by DeVilbiss Ransburg, or when others have modified the DeVilbiss Ransburg control system, unless reviewed and approved in writing by an authorized DeVilbiss Ransburg Technical Representative.

2.

Labor or incidental costs occasioned by removal, replacement or repair of rotary atomizer or air turbine (other than by DeVilbiss Ransburg) unless we have given previous specific written or telegraphic authorization for repair by someone other than DeVilbiss Ransburg.

3.

Rotary atomizers determined by DeVilbiss Ransburg not to have been installed and maintained in accordance with DeVilbiss Ransburg service instruction LN9500-00 (latest edition).

4.

Cost of repair/replacement and return transportation from DeVilbiss Ransburg of merchandise determined not to be defective.

**There is no other express warranty. Implied warranties, including those of merchantability and fitness for a particular purpose are limited to one year from purchase and to the extent permitted by law any and all implied warranties are excluded. This is the exclusive remedy, and liability for consequential or incidental damages under any and all warranties are excluded to the extent exclusion is permitted by law. Some states do not allow limitations on how long an implied warranty lasts, or the limitation or exclusion of consequential or incidental damages, so the above limitation or exclusion may not apply to you.**

This warranty gives you specific legal rights, and you may also have other rights which vary from state to state.

In the event of malfunction, first ensure that the equipment is the correct equipment to do the job required, is properly installed and adjusted, and is correctly maintained and operated. Then, if a claim is made that DeVilbiss Ransburg equipment or a part thereof does not operate properly, contact your DeVilbiss Ransburg distributor through which the equipment was purchased or your DeVilbiss Ransburg representative.

**WORLDWIDE LOCATIONS****USA LOCATIONS****Toledo, Ohio**

DeVilbiss Ransburg Industrial Liquid Systems  
320 Phillips Avenue  
Toledo, Ohio 43612

## Mailing Address:

P.O. Box 913  
Toledo, Ohio 43697-0913  
Telephone: (419) 470-2000  
Fax: (419) 470-2270

**Angola, Indiana**

DeVilbiss Ransburg Industrial Liquid Systems  
1810 North Wayne Street  
Angola, Indiana 46703  
Phone: (219) 665-8800  
Fax: (219) 665-8516

**EUROPEAN LOCATIONS****Bournemouth, England**

DeVilbiss Ransburg Industrial Liquid Systems  
Ringwood Road  
Bournemouth BH 11 9 LH, England  
Tel.: 011-44-202-571111  
Fax: 011-44-202-581940

**Valence, France**

DeVilbiss Ransburg Industrial Liquid Systems  
163 a 171, Avenue des Aureats  
B.P. 1453  
26014 Valence (Cedex), France  
Telephone: 011-33-75-75 27 00  
Fax: 011-33-75-75 27 79

**Dietzenbach, Germany**

DeVilbiss Ransburg Industrial Liquid Systems  
Justus-von-Liebig-Strasse 31  
D-6057 Dietzenbach 1  
West Germany  
Telephone: 49-6074-403-1  
Fax: 49-6074-403-281

**Barcelona, Spain**

DeVilbiss Ransburg Industrial Liquid Systems  
Edificio Torre de Cataluna  
Avenida Roma 2y4  
08014 Barcelona, Spain

**ASIA/PACIFIC LOCATION****Tokyo, Japan**

DeVilbiss Ransburg Industrial Liquid Systems  
Division of Ransburg Industrial Finishing K.K.  
5-3, Higashi-Rokugo, 3-chome  
Ohtaku, Tokyo, 144, Japan  
Telephone: 011-81-33-732-5212  
Fax: 011-81-33-736-2135

**Glen Waverley, Victoria, Australia**

ITW Finishing Systems and Products Group  
P. O. Box 47  
Glen Waverley, Victoria 3150, Australia  
Telephone: 61-3-550-1811  
Fax: 61-3-560-5329

Technical / Service Assistance (800) 233-3366

Models and specifications subject to change without notice.

Printed in U.S.A.

All rights reserved

**DEVILBISS  
RANSBURG**
**INDUSTRIAL LIQUID SYSTEMS**

© 1992 DeVilbiss Ransburg Industrial Liquid Systems