

SERVICE INSTRUCTION

AEROBELL™ MOUNTING HARDWARE

Aerobell Mounting Hardware			
Mounting Assy. #	Description	Type of Application	Figure #
RPM-433	Mounting Bracket Assembly	Aerobell Extended Shroud	1
RPM-434	Support and Tube Assembly	Aerobell W/ARCBAR Power Supply	2
RPM-436	Mounting Bracket and Clamp Assembly	Aerobell W/Charged Gun Mounting Post	3

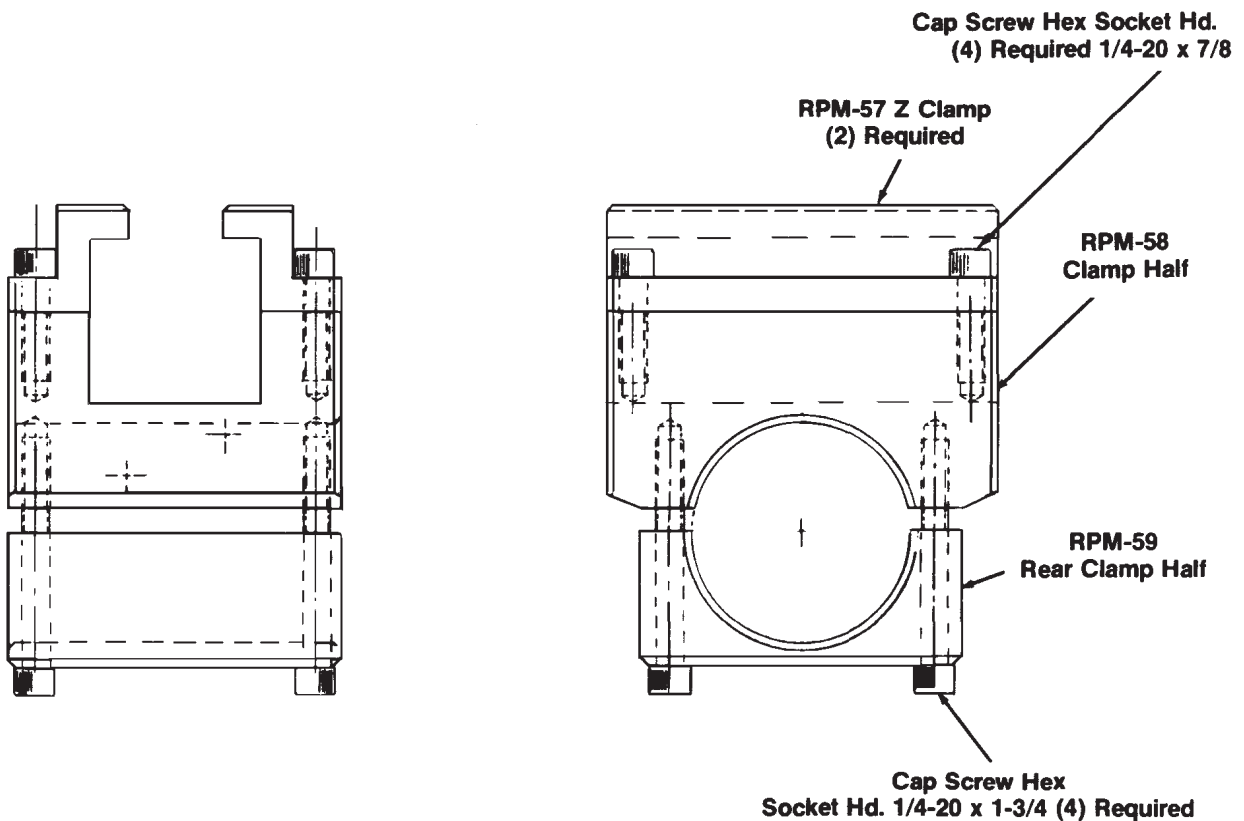

Figure 1: RPM-433 Mounting Bracket Assembly

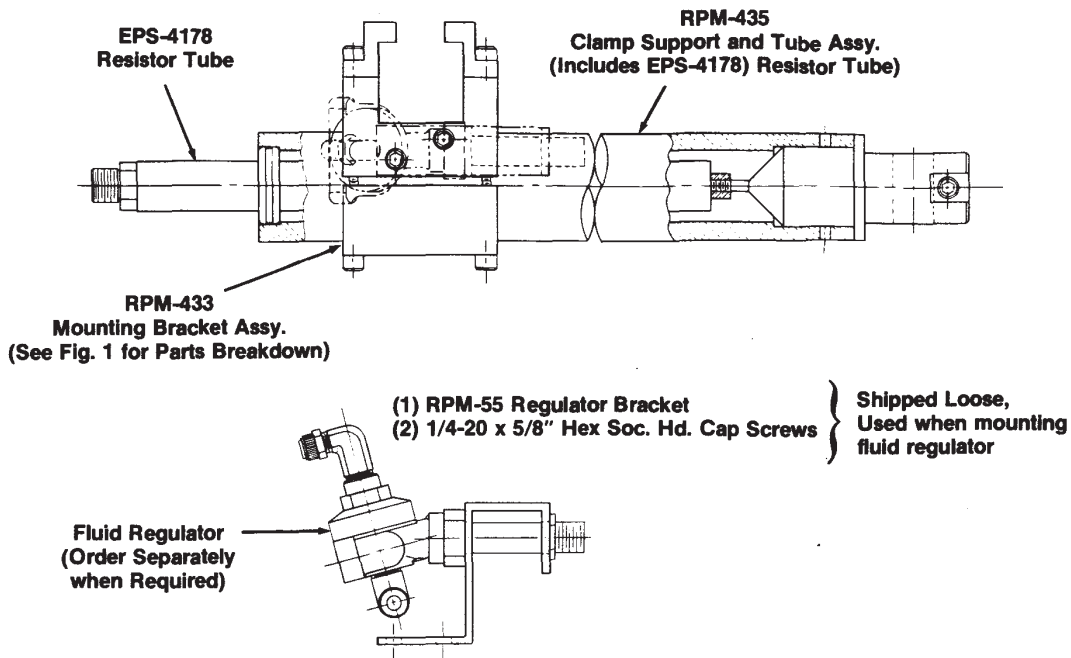

Figure 2: RPM-434 Support and Tube Assembly

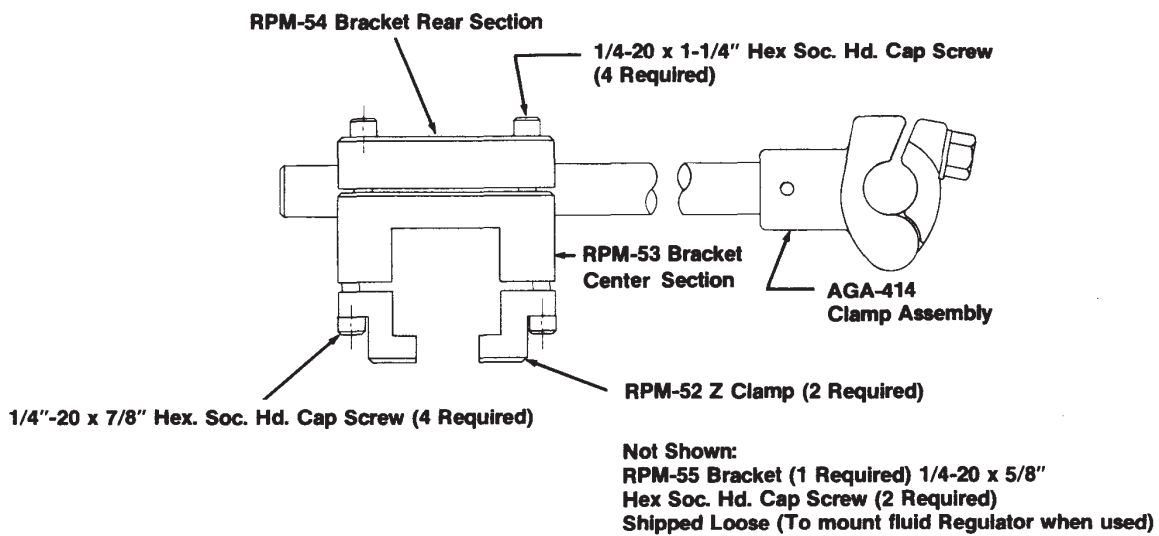

Figure 3: RPM-436 Mounting Bracket and Clamp Assembly

Manufacturing
 1910 North Wayne Street
 Angola, Indiana 46703-9100
 Telephone: 260/665-8800
 Fax: 260/665-8516
 www.ransburg.com

Technical / Service Assistance
 Telephone: 800/ 233-3366

Technical Support Representative will direct you to the appropriate telephone number for ordering Spare Parts.