

9060 HIGH VOLTAGE CONTROLLER for No. 2 Process™ Handgun (HV2 - Air Motor)



MODEL: 80102-31X (Air Motor)
ATEX APPROVED FOR USE WITH 80086-XX

IMPORTANT: Before using this equipment, carefully read **SAFETY PRECAUTIONS**, starting on page 1, and all instructions in this manual. Keep this Service Manual for future reference.



Service Manual Price: \$50.00 (U.S.)

CONTENTS

	PAGE
SAFETY:	1-6
SAFETY PRECAUTIONS	1
HAZARDS / SAFEGUARDS.....	2-5
INTRODUCTION:	7-12
GENERAL DESCRIPTION.....	7
SAFETY FEATURES	7
DISPLAYS	7
SPECIFICATIONS	8
CONTROLLER FEATURES.....	9
OPERATOR INTERFACE.....	10
SWITCHES.....	10
LEDS	10
BUTTONS.....	10-11
CONNECTION INTERFACE.....	11
CONNECTORS.....	11
FUSES.....	11
SPARE FUSES.....	11
SIGNAL INTERFACE.....	12
INSTALLATION:	13-16
GENERAL INFORMATION	13
LOCATION OF THE 9060.....	13
AC INPUT CONNECTIONS	13-14
SAFETY GROUND	14
INPUT VOLTAGE SELECTION	14
HIGH VOLTAGE CABLE.....	14
NO. 2 PROCESS HANDGUN TRIGGER SIGNAL	16
OPERATION:	17-23
START-UP	17
BASIC OPERATIONS.....	17-18
LOCKOUTS	18-19
KV TEST JUMPER	19
SETPOINT OPERATIONS.....	20
FAULT DESCRIPTIONS	20-23

CONTENTS

	PAGE
MAINTENANCE:	24-26
TRUBLESHOOTING GUIDE	24
FAULT TROUBLESHOOTING GUIDE.....	24-26
PARTS IDENTIFICATION:	27-28
HIGH VOLTAGE CONTROLLER MODEL IDENTIFICATION	27
PARTS LIST	28
ACCESSORIES:	29
ACCESSORIES LIST.....	29
WARRANTY POLICIES:	30
LIMITED WARRANTY	30

Ransburg

SAFETY

SAFETY PRECAUTIONS

Before operating, maintaining or servicing any Ransburg electrostatic coating system, read and understand all of the technical and safety literature for your Ransburg products. This manual contains information that is important for you to know and understand. This information relates to **USER SAFETY** and **PREVENTING EQUIPMENT PROBLEMS**. To help you recognize this information, we use the following symbols. Please pay particular attention to these sections.

A WARNING! states information to alert you to a situation that might cause serious injury if instructions are not followed.

A CAUTION! states information that tells how to prevent damage to equipment or how to avoid a situation that might cause minor injury.

A NOTE is information relevant to the procedure in progress.

While this manual lists standard specifications and service procedures, some minor deviations may be found between this literature and your equipment. Differences in local codes and plant requirements, material delivery requirements, etc., make such variations inevitable. Compare this manual with your system installation drawings and appropriate Ransburg equipment manuals to reconcile such differences.

Careful study and continued use of this manual will provide a better understanding of the equipment and process, resulting in more efficient operation, longer trouble-free service and faster, easier troubleshooting. If you do not have the manuals and safety literature for your Ransburg system, contact your local Ransburg representative or Ransburg.



WARNING

► The user **MUST** read and be familiar with the Safety Section in this manual and the Ransburg safety literature therein identified.



► This manual **MUST** be read and thoroughly understood by **ALL** personnel who operate, clean or maintain this equipment! Special care should be taken to ensure that the **WARNINGS** and safety requirements for operating and servicing the equipment are followed. The user should be aware of and adhere to ALL local building and fire codes and ordinances as well as **NFPA-33 SAFETY STANDARD**, prior to installing, operating, and/or servicing this equipment.





WARNING

► The hazards shown on the following page may occur during the normal use of this equipment. Please read the hazard chart beginning on page 2.

AREA Tells where hazards may occur.	HAZARD Tells what the hazard is.	SAFEGUARDS Tells how to avoid the hazard.
<p>Spray Area</p> 	<p>Fire Hazard</p> <p>Improper or inadequate operation and maintenance procedures will cause a fire hazard.</p> <p>Protection against inadvertent arcing that is capable of causing fire or explosion is lost if any safety interlocks are disabled during operation. Frequent Controller shutdown indicates a problem in the system requiring correction.</p>	<p>Fire extinguishing equipment must be present in the spray area and tested periodically.</p> <p>Spray areas must be kept clean to prevent the accumulation of combustible residues.</p> <p>Smoking must never be allowed in the spray area.</p> <p>The high voltage supplied to the atomizer must be turned off prior to cleaning, flushing or maintenance.</p> <p>When using solvents for cleaning:</p> <p>Those used for equipment flushing should have flash points equal to or higher than those of the coating material.</p> <p>Those solvents used for cleaning must have a flash point at minimum of 5°C (9°F) greater than ambient temperature. It is the end users responsibility to ensure this condition is met.</p> <p>Spray booth ventilation must be kept at the rates required by NFPA-33, OSHA, and local codes. In addition, ventilation must be maintained during cleaning operations using flammable or combustible solvents.</p> <p>Electrostatic arcing must be prevented.</p> <p>Test only in areas free of combustible material.</p> <p>Testing may require high voltage to be on, but only as instructed.</p> <p>Non-factory replacement parts or unauthorized equipment modifications may cause fire or injury.</p> <p>If used, the key switch bypass is intended for use only during setup operations. Production should never be done with safety interlocks disabled.</p> <p>Never use equipment intended for use in waterborne installations to spray solvent based materials.</p> <p>The paint process and equipment should be set up and operated in accordance with NFPA-33, NEC, and European Health and Safety Norms.</p>

<p>AREA</p> <p>Tells where hazards may occur.</p>	<p>HAZARD</p> <p>Tells what the hazard is.</p>	<p>SAFEGUARDS</p> <p>Tells how to avoid the hazard.</p>
<p>Spray Area</p> 	<p>Fire and/or explosion.</p>	<p>Electrostatic arcing MUST be prevented.</p> <p>The 78789 control panel, LEPS5001 power supply and all other electrical equipment must be located outside Class I or II, Division 1 or 2 hazardous areas, in accordance with NFPA-33.</p> <p>Test only in areas free of flammable or combustible materials.</p> <p>The current overload sensitivity MUST be set as described in the OVERLOAD ADJUSTMENT Procedures section of this manual. Protection against inadvertent arcing that is capable of causing fire or explosion is lost if the current overload sensitivity is not properly set. Frequent power supply shutdown indicates a problem in the system which requires correction.</p> <p>Always turn the control panel off prior to flushing, cleaning, or working on spray system equipment.</p> <p>Ensure that the control panel is interlocked with the ventilation system and conveyor in accordance with NFPA-33, EN 50176.</p> <p>Have fire extinguishing equipment readily available and tested periodically.</p>
<p>General Use and Maintenance</p> 	<p>Improper operation or maintenance may create a hazard.</p> <p>Personnel must be properly trained in the use of this equipment.</p>	<p>Personnel must be given training in accordance with the requirements of NFPA-33, EN 60079-0.</p> <p>Instructions and safety precautions must be read and understood prior to using this equipment.</p> <p>Comply with appropriate local, state, and national codes governing ventilation, fire protection, operation maintenance, and housekeeping. Reference OSHA, NFPA-33, EN Norms and your insurance company requirements.</p>

AREA Tells where hazards	HAZARD Tells what the hazard is.	SAFEGUARDS Tells how to avoid the hazard.
<p>Electrical Equipment</p> 	<p>High voltage equipment is utilized. Arcing in areas of flammable or combustible materials may occur. Personnel are exposed to high voltage during operation and maintenance.</p> <p>Protection against inadvertent arcing that may cause a fire or explosion is lost if safety circuits are disabled during operation.</p> <p>Frequent power supply shut-down indicates a problem in the system which requires correction.</p> <p>An electrical arc can ignite coating materials and cause a fire or explosion.</p>	<p>The power supply, optional remote control cabinet, and all other electrical equipment must be located outside Class I or II, Division 1 and 2 hazardous areas. Refer to NFPA-33 or EN 50176.</p> <p>Turn the power supply OFF before working on the equipment.</p> <p>Test only in areas free of flammable or combustible material.</p> <p>Testing may require high voltage to be on, but only as instructed.</p> <p>Production should never be done with the safety circuits disabled.</p> <p>Before turning the high voltage on, make sure no objects are within the sparking distance.</p>
<p>Toxic Substances</p> 	<p>Certain material may be harmful if inhaled, or if there is contact with the skin.</p>	<p>Follow the requirements of the Material Safety Data Sheet supplied by coating material manufacturer.</p> <p>Adequate exhaust must be provided to keep the air free of accumulations of toxic materials.</p> <p>Use a mask or respirator whenever there is a chance of inhaling sprayed materials. The mask must be compatible with the material being sprayed and its concentration. Equipment must be as prescribed by an industrial hygienist or safety expert, and be NIOSH approved.</p>

AREA Tells where hazards may occur.	HAZARD Tells what the hazard is.	SAFEGUARDS Tells how to avoid the hazard.
<p>Spray Area / High Voltage Equipment</p> 	<p>There is a high voltage device that can induce an electrical charge on ungrounded objects which is capable of igniting coating materials.</p> <p>Inadequate grounding will cause a spark hazard. A spark can ignite many coating materials and cause a fire or explosion.</p>	<p>Parts being sprayed must be supported on conveyors or hangers and be grounded. The resistance between the part and ground must not exceed 1 megaohm. (Reference NFPA-33 or EN 50176)</p> <p>All electrically conductive objects in the spray area, with the exception of those objects required by the process to be at high voltage, must be grounded.</p> <p>Any person working in the spray area must be grounded.</p> <p>Unless specifically approved for use in hazardous locations, the power supply and other electrical control equipment must not be used in Class 1, Division 1 or 2 locations or Class 1, Zone 0 for European Applications.</p>

NOTES

INTRODUCTION

GENERAL DESCRIPTION

The Ransburg No. 2 Handgun Process

The No. 2 Process™ is an electrical atomization method for applying coatings to objects electrostatically. The No. 2 Process Handgun system applies a high voltage, negative, DC charge to the applicator bell, creating an electrostatic field between the bell and the target object. The target is electrically grounded through its support which may be stationary or moving; or through an electrical connection to a known true earth ground.

A regulated pressure fluid system delivers coating material to the bell when the gun is triggered. There, the fluid travels across the face of the rotating bell and becomes charged. The fluid is electrically atomized at the edge of the bell forming a fine mist which, under the influence of the electrostatic field, is attracted to and deposited on the target object. The forces between the charged particles and the grounded target are sufficient to turn almost all overspray around and deposit it on the side and back surfaces of the target. Thus, a high percentage of the spray is deposited on the target and overspray is controlled.

The 9060 High Voltage Controller

The *Ransburg 9060 High Voltage Controller* (80102-31X) is used to provide high voltage for the No. 2 Process Handgun. It uses a combination of proven high voltage generation technology and microprocessor-based control. It uses a variable voltage output to drive a cascade that amplifies the voltage to a high kV level. It also uses current feedback information to maintain the desired set point. The processor circuitry provides the maximum in applicator transfer efficiency, while maintaining the maximum safety.

The 9060 Controller selection and adjustment of set point values is performed from the controller front panel. The triggering of the HV is initiated by the airflow switch built into the controller which senses airflow triggered by the No. 2 Process Handgun.

SAFETY FEATURES

The Ransburg 9060 High Voltage Controller provides maximized operational safety. The protections include detection of Ground Faults, Cable Faults, Feedback Signal Faults, Overvoltage, and Overcurrent. The microprocessor circuits provide a controlled output load curve, which limits the high voltage output to safe levels while monitoring control and feedback signals for unsafe conditions. Maximum operational safety is obtained when the correct applicator settings are used and when safe distances between the applicator and target are observed and followed. The maximum efficiency of the high voltage controller is based on load.

DISPLAYS

The front panel displays the high voltage set point as well as a reading of gun current output. The gun current is derived from feedback signals between the controller and the cascade.



Figure 1: 9060 High Voltage Controller (HV2)

NOTE

► The 9060 High Voltage Controller is factory supplied with a latch (#E5-1-065-091) that can be opened using the supplied key (#E3-2).

The 9060 High Voltage Controller is available as follows:

9060 Part No.	Used with No. 2 Gun Type	Gun No.
80102-311	Air Motor, Domestic	80086-XX
80102-312	Air Motor, European	80086-XX
80102-313	Air Motor, China	80086-XX

SPECIFICATIONS

Environmental

Operating Temperature: 0°C to +40°C

Storage and Shipping Temperature: -40°C to +85°C

(Allow power supply to go to room temperature before use)

Humidity: 95% Non-Condensing

Physical

Height: 16.5 cm (6.5 inches)

Width: 37.8 cm (14.9 inches)

Depth: 30.7 cm (12.1 inches)

Weight: 10.2 kg (22.5 lbs.)

Electrical

Input Voltage: 100-240 VAC

Frequency: 50 or 60 Hz

Current: 1 A max. RMS

Wattage: 40 watts (max.)

Output Voltage: 20-90kV MAX DC, adjustable in 1kV increments

Ground: Use known good earth ground

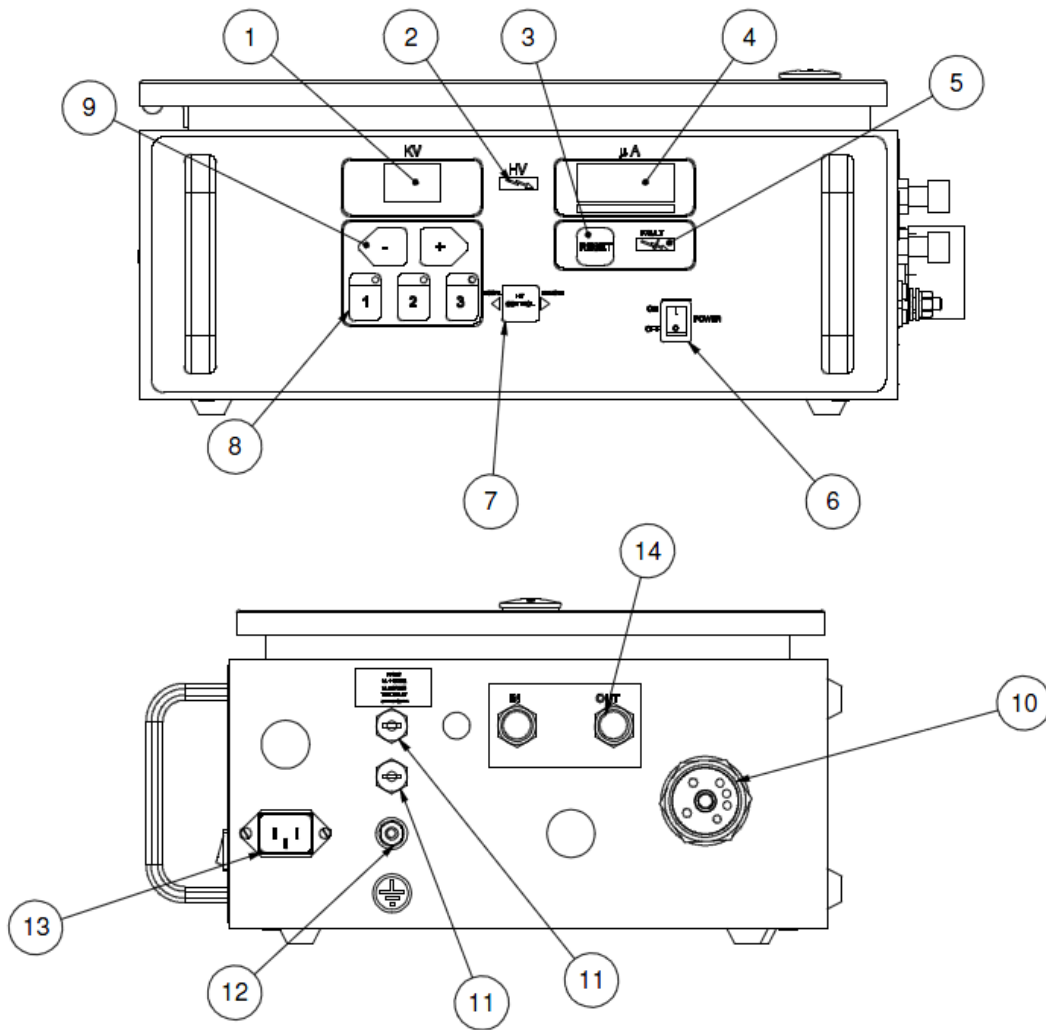

Figure 2: 9060 High Voltage Controller Features

9060 CONTROLLER FEATURES			
No.	Description	No.	Description
1	kV Display	9	kV Setpoint/Adjust Buttons
2	High Voltage On Indicator	10	High Voltage Cable Connector
3	Reset Button	11	Fuses
4	µA Display	12	Ground Lug
5	Fault Indicator	13	AC Inlet Receptacle
6	On-Off Switch	14	Air Flow Switch Hose Connections
7	Local/Remote Mode Indicator		
8	“One Touch” kV Setpoint Buttons		

OPERATOR INTERFACE

The 9060 Controller shown in Figure 3, has a simple operator interface consisting of 7 LEDs (Light Emitting Diodes), one (1) power switch, seven (7) buttons, one (1) current LED bargraph, and two (2) screens containing seven-segment displays.

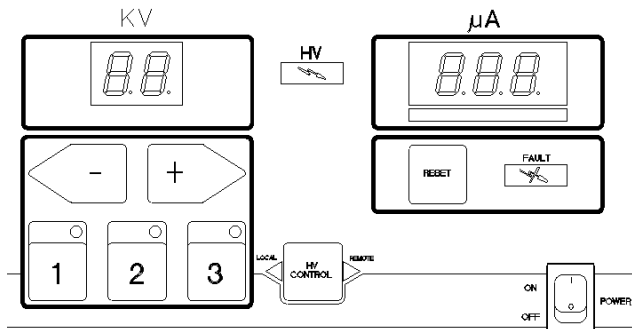

Figure 3: 9060 Operator Interface

SWITCHES

Power Switch

The 9060 Controller contains a single rocker switch for power On/Off selection. When the unit is powered on, the screens should be lit and display the gun display type information and the software version number for a short period of time.

LEDs

High Voltage On Indicator

The red High Voltage On Indicator is lit when a trigger signal has been received by the unit and the high voltage output from the cascade has been enabled.

Fault Indicator

The red Fault Indicator is lit when a fault occurs as determined by the microprocessor. When a fault occurs the light will turn on and the identification code for the fault will be displayed, blinking, on the μA meter display. For more information on the faults and fault ID codes, please refer the Fault Descriptions section in the Operations portion of this manual.

LOCAL Mode LED Indicator

The LOCAL mode LED indicator is a left pointing triangle and is located on the left side the HV control button on the center of the operator interface. This LED is lit when the Controller is used with the No. 2 Process Handgun.

Remote Mode LED Indicator

The remove mode LED indicator should **NOT** be lit for No. 2 Process Handgun units.

Active Preset LED Indicators (3)

The active preset LED indicators are located directly above each of the Preset Buttons. When a preset button is pushed to select the desired preset, in READY mode, the preset LED indicator directly above the button pressed will light up. Only one (1) preset light should be lit at any one time.

BUTTONS

The seven buttons on the operator interface are used to select the KV presets, reset overloads and faults, access other modes and to navigate as well as modify information that is displayed on the two seven-segment display screens (μA and kV).

Preset 1 Button

The Preset 1 Button (on the left below the kV display) is used by itself to select “Voltage Preset 1”. If pressed with the reset button, at the same time, the screen will display the resettable High Voltage ON operating hours for 3 seconds on the display screens.

Preset 2 Button

The Preset 2 Button (in the center below the kV display) is used by itself to select “Voltage Preset 2”. If pressed with the reset button, at the same time, the screen will display the non-resettable High Voltage ON operating hours for 3 seconds on the display screens.

Preset 3 Button

The Preset 3 Button (on the right below the kV display) is used to select “Voltage Preset 3”.

Left (-)/Right (+) Buttons

The left(-)/right(+) buttons are used to modify, decrease and increase respectively, the currently selected preset value. If the button is pressed and released, the preset value is changed by 1 kV at a time. If the button is held for over a 1/2 second, the value will begin changing by 5 kV increments.

Reset Button

The reset button is used to clear fault or overload conditions. This will NOT prevent any other active fault conditions from triggering a new fault.

HV Control Button

This button, shown in the center of Figure 3, is not functional for handgun units.

CONNECTION INTERFACE

The 9060 Controller connection interface shown in Figure 4, provides all of the required connections for setting up a No. 2 Process Handgun painting system. This connection interface consists of one (1) high voltage cable connector, one (1) ground lug connection, one (1) air flow switch connection, two (2) fuses, and one (1) AC inlet receptacle.

CONNECTORS

High Voltage Cable Connector

The high voltage cable connector is the largest connector and is located on the far right of the connection interface. This connector is designed for use with the superflex high voltage cable 20988 that connects with the No. 2 Process Handgun.

Ground Lug Connection

The ground lug connection is located directly below the fuses and has a ground logo sticker directly below it. This lug is provided as an external ground connection point used to ground the 9060 to an earth ground via a ground cable. This ground lug connection can also be used as the ground point for the high

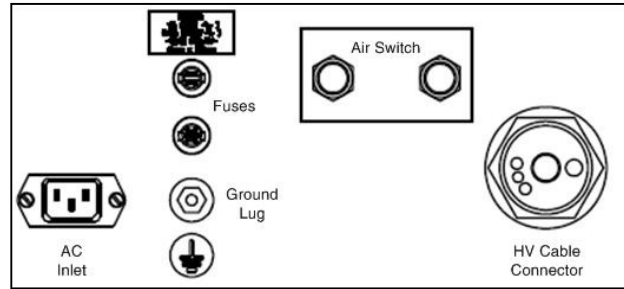

Figure 4: 9060 Connection Interface

voltage cable ground.

Air Flow Switch Connection

The air flow switch connection is installed to provide a pneumatic trigger signal for the No. 2 Process Handgun indicating that the trigger has been actuated. This signal is used to turn on the High Voltage output.

AC Inlet Receptacle

The AC inlet receptacle is a standard IEC C14 Appliance Inlet connector with a maximum rating of 250 VAC. It can handle both 110VAC and 240 VAC inputs at 50 or 60 Hz. The unit is shipped with the appropriate rated AC cord for the particular installation.

FUSES

Fuses

There are two (2) time delay fuses (250V, 1A, 5mm x 20mm) installed in fuse holders on the connection interface. They are located directly above the ground lug connection. They are present to provide a measure of safety against power surges through the AC input. The top fuse holder is connected in series between the HOT line (L) input connection and the Interlock AC line connection terminal 1TB-L2. The bottom fuse holder is connected in series between the neutral AC input connection and the neutral input connection of the AC line power filter.

Spare Fuses

The Controller also comes with two (2) spare fuses (250V, 1A, 5mm x 20mm) mounted in holders, inside the lid of the Controller.

SIGNAL INTERFACE

The 9060 Controller, when configured for use with the No. 2 Process Handgun, requires only one signal input for operation, the trigger signal.

Trigger Signal

The trigger signal input (J3-5) for a No. 2 Process Handgun comes **preconfigured** as a sinking input wired directly to the air flow switch. Please refer to "Installation" section of this service manual for more information.

INSTALLATION

GENERAL INFORMATION

The following section contains general information on the installation of 9060 High Voltage Controller.



WARNING

- ▶ The 9060 Controller **MUST** be located outside of the hazardous area.
- ▶ The User **MUST** read and be familiar with the "Safety" section of this manual.
- ▶ This manual **MUST** be read and thoroughly understood by **ALL** personnel who operate, clean, or maintain this equipment! Special care should be taken to ensure that the warnings and requirements of operating and servicing safely are followed. The user should be aware of and adhere to ALL local building and fire codes and ordinances as well as NFPA-33, OSHA, and all related country safety codes prior to installing, operating, and/or servicing this equipment.
- ▶ Only approved applicators should be used with the 9060 High Voltage Controller.

NOTE

- ▶ As each installation is unique, this information is intended to provide general installation information for the 9060 Controller. Consult your authorized Ransburg distributor for specific directions pertaining to the installation of your equipment.

LOCATION OF THE 9060

Install the Controller in an area **outside the hazardous location** in accordance with federal, state, and local codes. The area should protect the Controller from the possibility of environmental intrusion (such as dust or moisture), have ambient temperatures that do not exceed 40°C, and be as close to the applicator as possible to minimize the length of the high voltage cable.



CAUTION

- ▶ **DO NOT** locate the Controller near or adjacent to heat producing equipment such as ovens, high wattage lamps, etc.

AC INPUT CONNECTIONS

For non-conduit installations, plug the detachable AC line cord into the receptacle on the side of the 9060 Controller. Plug the other end of the line cord into a properly grounded 120 volt AC outlet.

For those installations where it is required to run the AC input wiring in conduit, perform the following:

1. **Ensure the AC line cord is unplugged** and remove the AC inlet receptacle wiring from TB1-N, TB1-L1 and TB1-EARTH GROUND (See Figures 5 and 7).
2. Remove the mounting hardware from the AC inlet receptacle and remove it from the side of Controller.
3. Install the Conduit Adapter Plate (supplied) in the hole where the AC inlet receptacle was removed (see Figure 6).
4. Install the AC input wiring (0.8mm² (18AWG) minimum) through the Conduit

Adapter Plate using conduit and wire to TB1 as follows:

- Hot/Line to TB1-L1
- Neutral/Common to TB1-N
- Ground to TB1-EARTH GROUND

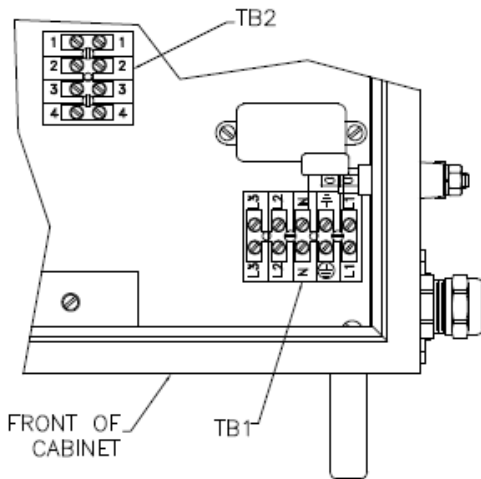

Figure 5: Location of TB1 & TB2 in Controller

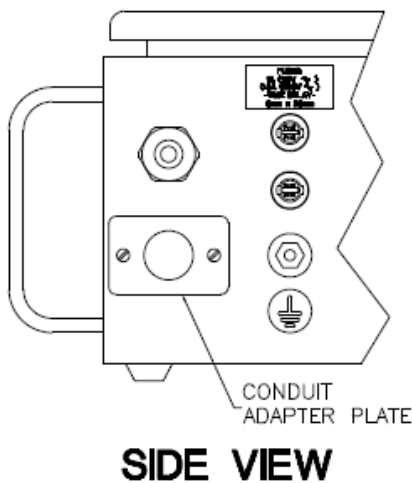

Figure 6: Installation of Conduit Adapter Plate

SAFETY GROUND

Crimp the appropriate connector onto the ground wire assembly and install from the Controller ground stud, located on the side panel, to a true earth ground.

CAUTION

▶ The ground wire assembly **MUST** be connected from the Controller ground stud to a true earth ground.

INPUT VOLTAGE SELECTION

The 9060 Controller accepts universal input voltage between 100 and 240 VAC at 50 or 60 Hz. There is no need to change any switch settings when changing input from 110 to 240 VAC or from 240 to 110 VAC.

NOTE

▶ **All 9060 units** (80102-31X) shipped from the factory for either 110 VAC input or 240 VAC input will have a 72771-06, 1 Amp front panel fuses installed.

HIGH VOLTAGE CABLE

Position the No. 2 Process Handgun in the spray area and route the high voltage cable to the Controller. The cable should be routed so that it is not damaged by foot and vehicle traffic and also so that it is not close to areas of high temperature (129°F+). The operator should have free movement of the applicator and all bend radii of the cable should not be less than 6-inches (15 cm). Connect the high voltage cable to the Controller and tighten the retaining nut and set screw. If during the routing of the high voltage cable it is required to remove it from the No. 2 Handgun, care should be taken when reinstalling so that the high voltage cable is completely engaged.

WARNING

▶ The Controller **MUST** be **OFF** when the No. 2 Handgun is removed or reinstalled.

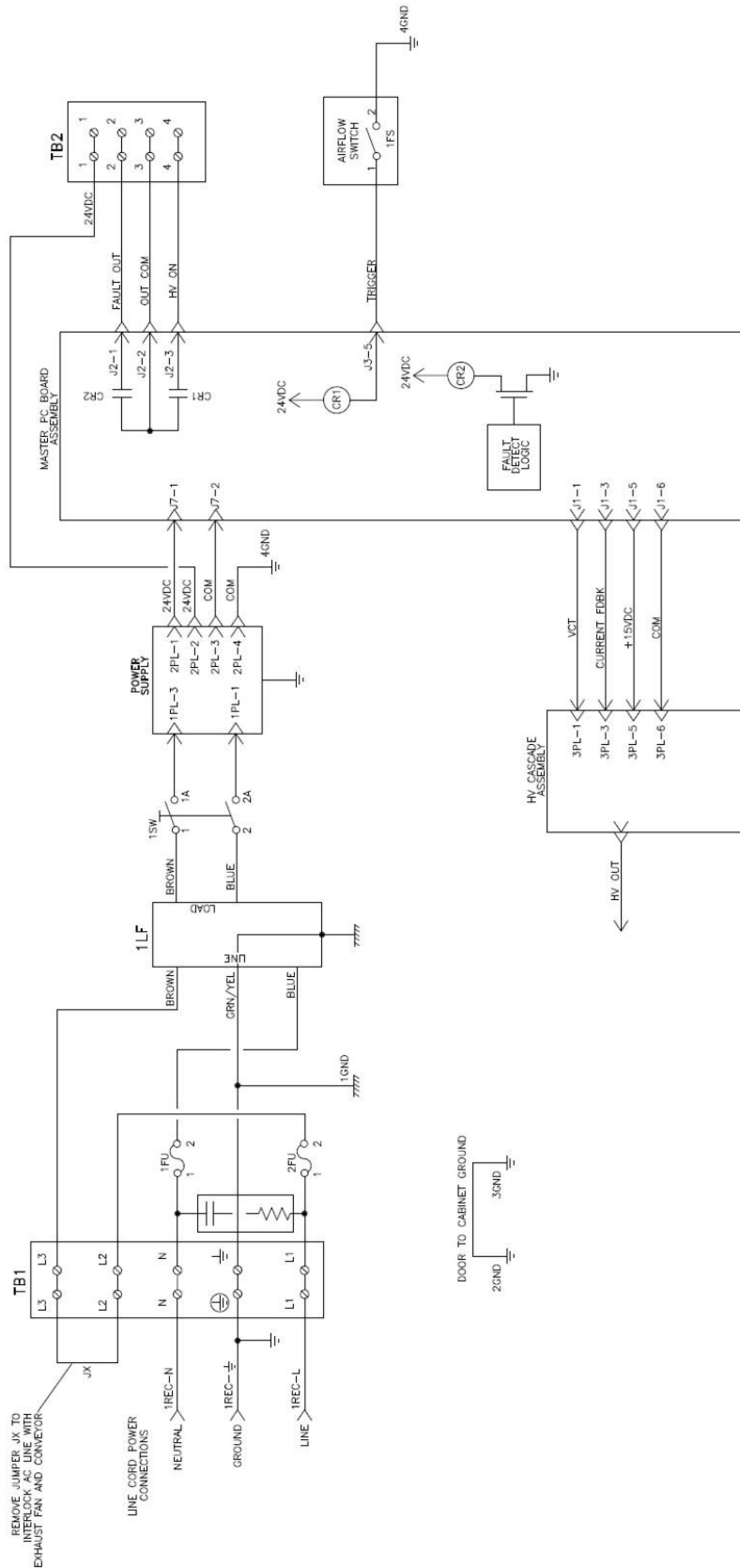

Figure 7: Controller Schematic

NO. 2 PROCESS HAND-GUN TRIGGER SIGNAL

The No. 2 Process Handgun uses a flow switch (13742-02) to provide the trigger signal. The listed flow switch is mounted inside the 9060 Controller chassis via the Air Flow Switch Connector on the side panel. When the No. 2 Process Handgun trigger is pressed and flow starts, the flow switch is activated and triggers the high voltage.

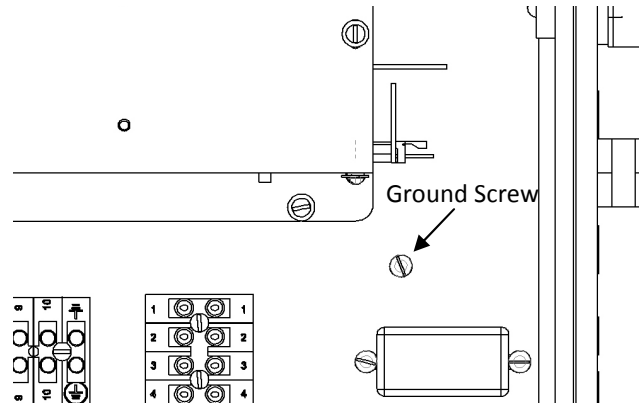

Figure 8: Ground Screw on Base Plate

For reference, when replacing a flow switch, perform the following:

1. **Turn the 9060 Controller off, disconnect it from its AC source, and remove the fuses.**

! WARNING

➤ **ALWAYS** double check that the Controller is **unplugged from its AC outlet** before working with any internal wiring.

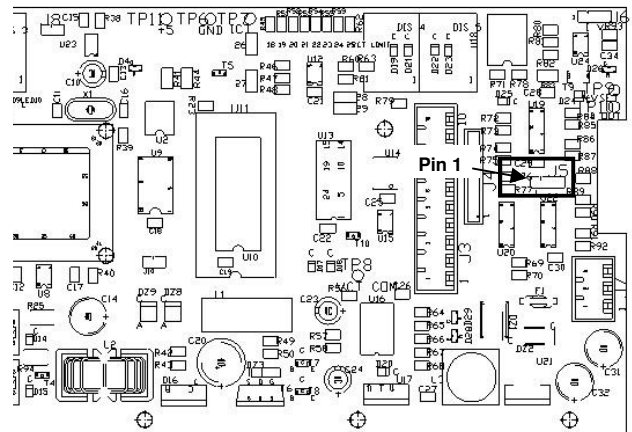

Figure 9: PC Mainboard Jumper J5 Location

2. Open the controller cabinet door.
3. If the flow switch is being used, connect the ground (green) lead from the flow switch to the ground screw on the base plate shown in Figure 8. The trigger signal (blue) lead should be connected to the trigger signal input on the JB-5 plug header that is connected to the PC board.
4. Verify that J5, shown in Figure 9, has the shunt covering pins 1 and 2.
5. Secure the cabinet door, replace the fuses, and reconnect the AC source.

OPERATION

START-UP

After all installation procedures are completed, operation of the applicator may begin. When the ON-OFF switch is turned on, the kV display will show the applicator type the 9060 Controller is configured for and the μA (microamp) display will show the current software revision level as shown in Figure 10. These items are displayed for approximately 10 seconds.

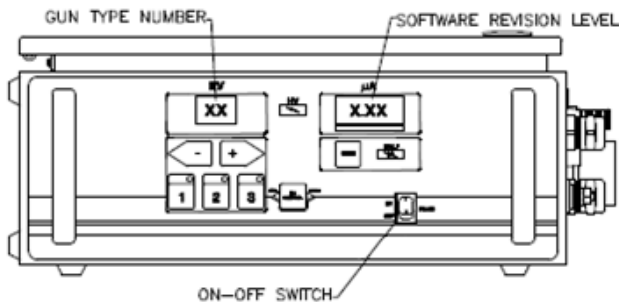

Figure 10: Controller Start-Up Display

The controller comes preconfigured for the No. 2 Process Handgun (Air Motor) from the factory. The following table lists the display value and jumper setting for the unit. This table is a **reference** to verify that the gun configuration jumpers are in their correct positions if unexpected behavior is observed.

START-UP DISPLAY		
Type	Unit (Gun)	Jumpers
90	No. 2 Handgun (Air Motor)	10, 11

After the initial start-up delay, the unit will be configured for the applicator based on the gun type jumper settings and is ready for standard operation.

! WARNING

► **DO NOT** adjust the gun configuration jumpers. If they are incorrect, contact your Ransburg representative.

! WARNING

► **USE ONLY** the gun type configuration for the No. 2 Process Handgun. Using the wrong configuration may allow for operation outside the recommended parameters and values for the applicator and can result in **damage** or **un-safe operation**.

NOTE

► During start-up, the gun trigger should **NOT** be pressed. An active trigger signal will cause a non-resettable **boot fault** (bF) and prevent the unit from being operated. This is designed to prevent unintended firing of the high-voltage immediately after start-up. Please refer to the “Fault Section” of this manual for more information.

BASIC OPERATIONS

The basic operations are general operations that are available.

Triggering

High voltage is actuated by the presence of an active trigger signal. This is normally accomplished by pulling the trigger of the No. 2 Process Handgun to start the flow of air through the applicator. The flow of air activates the air flow switch which sends a trigger signal to the 9060 unit.

The kV setpoint is displayed on the kV display, the actual current draw on the μA display, and the high voltage light illuminates. Under the μA display is a bar graph meter that illuminates according to the actual current draw shown in Figure 11. The green and yellow regions of the bar graphs meter indicate output current is in the optimum range for maximum transfer efficiency. The red region of the bar graph indicates high output current causing decreased

transfer efficiency. If high output, check maintenance of applicator and external equipment of the power supply.

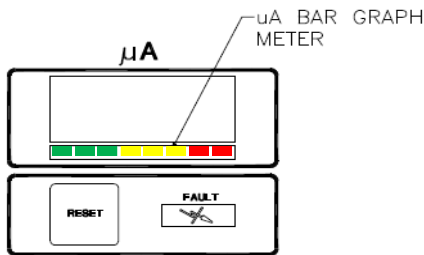

Figure 11: μ A Bar Graph Meter Display

Measuring “High Voltage On” Time

The 9060 High Voltage Controller records the amount of time the high voltage is triggered on up to 99,999 hours. This value is display on the kV and μ A displays of the unit. There are two registers that retain this information, one that may be reset, the other that is permanently retained in memory. The number of hours the unit’s high voltage has been on may be displayed by depressing at the same time the preset 1 and reset buttons (See Figure 12). The display will show hours of use for 3 seconds. This is the resettable register.

To reset this register, press the reset button while the hours are displayed.

To view the non-resettable register, press the preset 2 and reset buttons at the same time. This display will show the hours for 3 seconds.

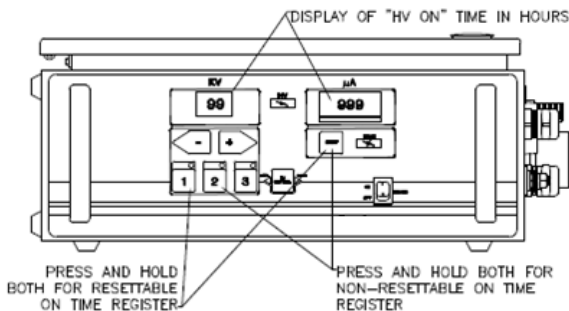

Figure 12: Display “High Voltage On” Time

LOCKOUTS

There are lockouts that may be done at the PC

board (see Figure 13). These lockouts may be used individually or in combination as required. If the jumpers are disconnected, the original functions are re-enabled. After changing any jumpers, the AC power must be cycled for the new setting to take affect.

NOTE

➤ Some lockouts are sealed using sealant to prevent them from being modified for safety reasons. These lockouts should **ONLY** be modified by Ransburg Authorized Representatives.

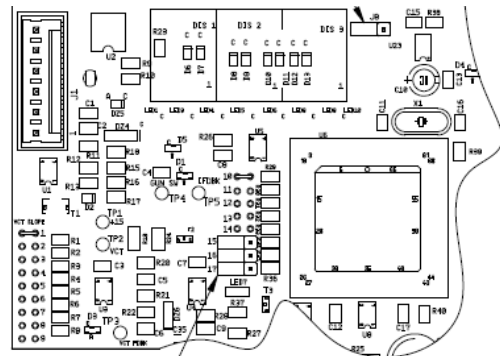

LOCKOUT JUMPER LOCATIONS

Figure 13: Lockout Jumper Location

Front Panel Lockout

This feature locks out any changes to the kV setting from the front panel of the Controller.

1. Set the kV to the desired value using the front panel buttons. This must be set prior to installing the jumper.
2. Turn AC power off and access the interior of the Controller.
3. Place the jumper across the two (2) pins at location 16 on the main PC board (See Figure 14).
4. Close the Controller and turn AC power back on. Pressing the front panel +, -, or setpoint buttons will now have no affect on the kV setting.

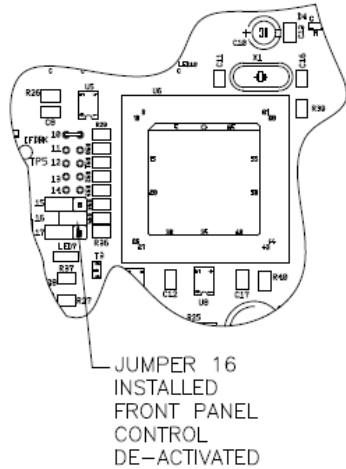

Figure 14: Jumper Location - Front Panel Lockout

Overload

The overload circuit may be activated for applications that require overload indication or notification of high current draws of the applicator. The default overload value is set in the software to the maximum microamp rating minus 10 microamps.

1. Turn AC power off and access the interior of the Controller.
2. Place the jumper across the two (2) pins at location 17 on the main PC board (See Figure 15).
3. Close the Controller and turn AC power back on. An overload fault will now occur if the microamp display exceeds the overload value.

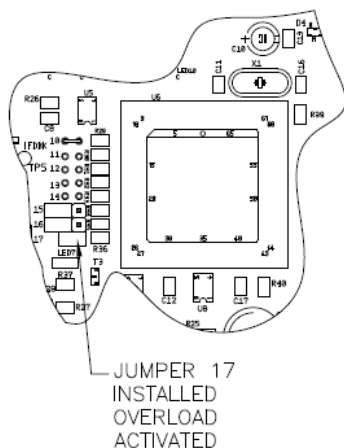

Figure 15: Jumper Location - Overload Activation

KV TEST JUMPER

To assist in testing and troubleshooting, a jumper (J8) has been added to the main PC board. By covering (shorting) both terminals of this jumper, the high voltage of the spray applicator can be activated. Thus, for testing and troubleshooting, high voltage output can be obtained without the need to trigger air through the spray applicator. **After testing, the jumper must be repositioned so that it covers only one terminal (open) or the high voltage will stay on all the time.** See Figure 16 for the location of KV test jumper J8.

! WARNING

► If jumper J8 is left covering (shorting) both terminals, high voltage will be on whenever the AC power is turned on.

NOTE

► Use Ransburg Calibrated Equipment ONLY for testing and troubleshooting. Refer to the “Accessories” section of this manual for part numbers for testing equipment.

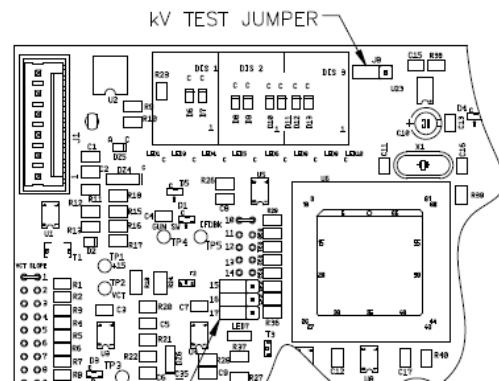

Figure 16: Lockout Jumper Location

SETPOINT OPERATIONS

Voltage Setpoints

The voltage on the 9060 High Voltage Controller is adjustable between 20 kV and full kV DC. There are 3 voltage setpoints (presets); 1, 2, and 3. Each of these setpoints can be individually adjusted between 20 kV and full kV DC. The three (3) factory preset voltages are listed in the following table:

Factory Presets	
Preset	Value
1	Full kV minus 20 kV
2	Full kV minus 10 kV
3	Full kV

NOTE

➤ The full kV DC value is determined by the gun type configuration for the particular applicator that is being used, **NOT** the full KV value of the cascade.

Setting the Setpoint

When the No. 2 Handgun is off, the present setpoint can be changed by pressing the 1, 2, or 3 buttons on the front panel shown in Figure 17. The setpoint that is currently selected will have the LED light in the upper right corner of the button lit.

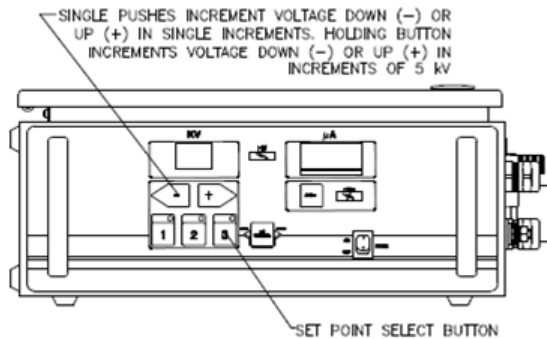

Figure 17: kV Adjust/Setpoint Buttons

Adjusting Presets

To adjust one of the preset setpoints, ensure the No. 2 Handgun is off in LOCAL mode and

select the desired setpoint by pressing the corresponding setpoint button. The setpoint can then be adjusted between 20 kV and full kV using the + and - buttons on the front panel of the 9060 Controller shown in Figure 17. Single pushes of the + or - buttons will increment or decrement the currently selected preset in units of 1. When the + or - buttons are held in for longer than a 1/2 second, the kV display will begin incrementing or decrementing in units of five (5).

Resetting Faults

During operation, various faults can occur based upon the operating conditions or if any problems with the 9060 unit arise. If a fault occurs, to reset a fault, turn off the No. 2 Handgun and press the Reset Button. This will clear the fault status and put the unit back into operation unless a fault condition is still present. Please refer to the "Fault Description" portion of the Operation Section of this Service manual for more information on a specific fault and how to correct it.

NOTE

➤ There is a **5 second fault reset delay timer** that **inhibits** the triggering of high voltage immediately after a fault reset.

FAULT DESCRIPTIONS

For in depth troubleshooting information on the 9060, please refer to the "Fault Troubleshooting" portion of the Maintenance Section of this service manual. If a fault occurs, the Fault Indicator on the front of the Controller will light and a fault code will be displayed on the microamp display. Faults can be reset by pressing the Reset button on the front of the Controller or by using the remote I/O reset signal.

NOTE

➤ **Any** fault code not listed that appear on the screen are a likely indication of a PC board failure due to possible arc damage.

Cable Fault (CF)

This fault will occur if high voltage is active and the microprocessor detects that no current is being supplied to the applicator. This indicates a connection problem from the control unit to the cascade or handgun barrel assembly. Typical causes include a faulty low voltage cable, stuck pins on the plug assembly, or contaminated contacts on the applicator. This may also indicate a faulty barrel assembly for a handgun. This could also indicate a connection problem between the pc board and the high voltage section. Check the wiring harness for loose pins, or replace the high voltage section. For additional information, refer to the Fault Troubleshooting Section.

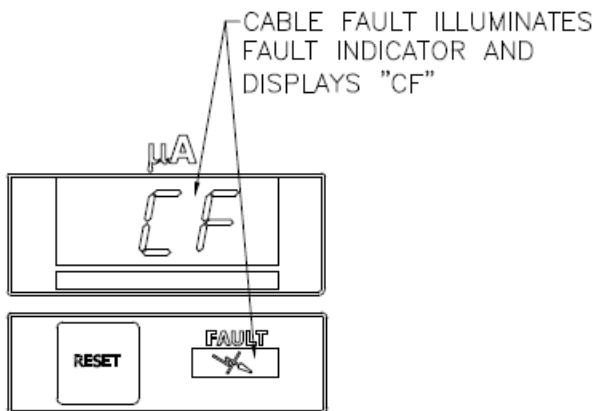

Figure 18: Cable Fault Display

Ground Fault (GF)

If this fault occurs, the fault indicator on the control unit will illuminate, a GF indication will show in the μA display. This fault will occur if the microprocessor detects a loss of ground at the high voltage section. If this fault occurs, reset the fault. This fault can be caused by a broken ground path between the applicator and the control unit and may indicate a faulty cable or plug assembly. It can also be caused by a broken ground path between the high voltage section and the pc board. Check the wiring to the high voltage section. For more information, refer to Fault Troubleshooting Section.

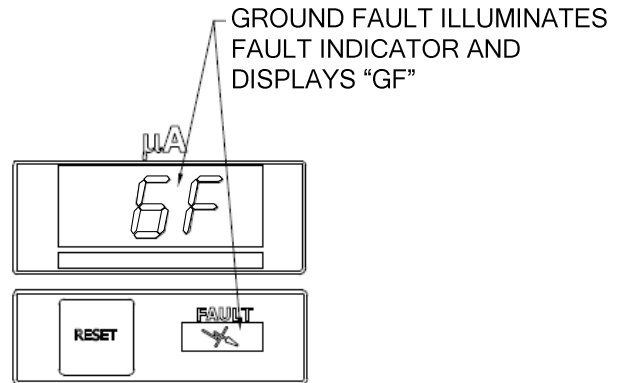

Figure 19: Ground Fault Display

Overload Fault (OL)

This fault will occur if the overload feature is active (see 'Overload Activation' previously in the "Operation" section) and the output current exceeds the overload current value. This can be caused by excessive overspray on the applicator or paint formulation that is too conductive. Clean the applicator, check the paint formulation, or move overload jumper (JP17) to the open position.

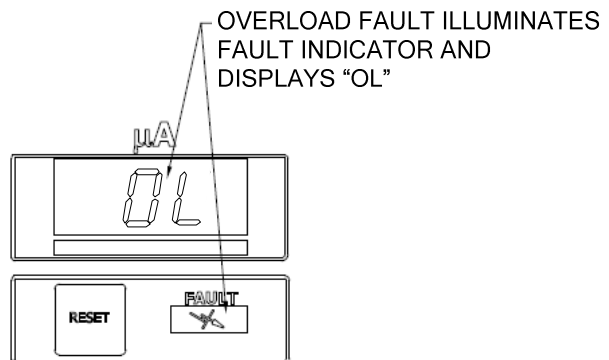

Figure 20: Overload Fault Display

Current Limit Fault (CL)

This fault occurs if the output current exceeds the maximum current by $20\mu A$. This fault can be caused by excessive overspray on the applicator or a paint formulation that is too conductive. It may also be caused by a bad pc board. Clean the applicator, check the paint formulation, or replace the pc board. See Fault Troubleshooting Section for more information.

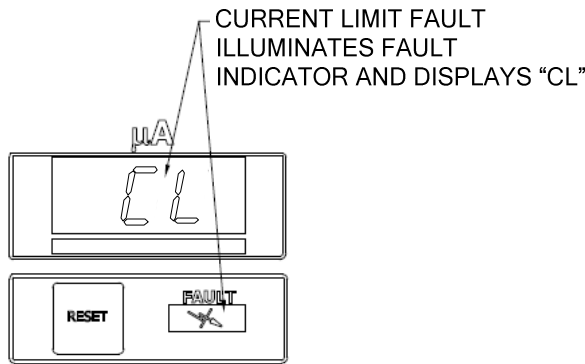

Figure 21: Current Limit Fault Display

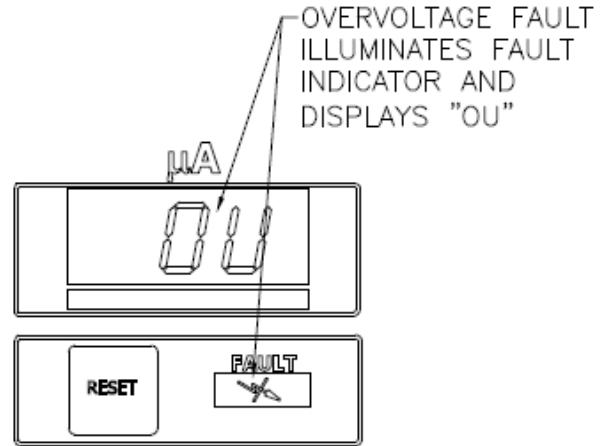

Figure 23: Over Voltage Fault Display

Voltage Cable Fault (UC)

This fault will occur if the microprocessor detects a loss of the voltage feedback signal. This can be caused by a failed high voltage cable, a failed high voltage section, or a failed pc board. Replace the high voltage cable and re-test. If still faulty, replace the high voltage section or pc board and re-test.

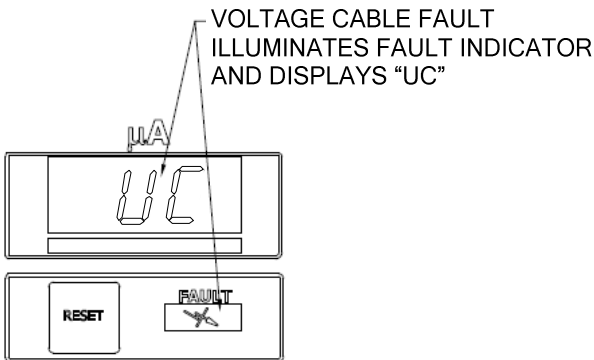

Figure 22: Voltage Cable Fault Display

Feedback Fault (FF)

This fault will occur if the microprocessor detects a loss of the current feedback signal. If this occurs, reset the fault. If this fault occurs repeatedly, refer to the Fault Troubleshooting Section to determine if the problem is with the high voltage section or the main pc board.

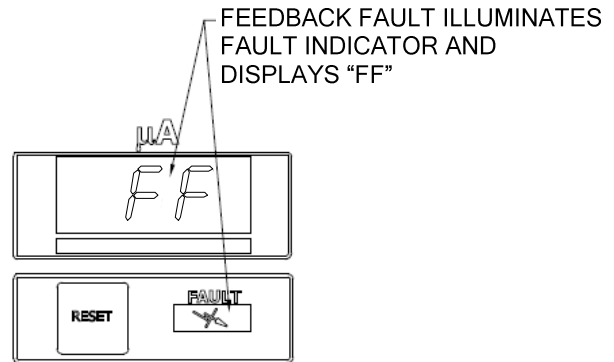

Figure 24: Feedback Fault Display

Over Voltage Fault (OU)

This fault will occur if the microprocessor detects the unit is trying to output voltage above the required for the specific applicator type. If this occurs, reset the Controller. If this fault continues to occur, replace the main PC board.

Boot Fault (bF)

This fault will occur during the start-up sequence if an active trigger signal is present. It is designed to prevent immediate triggering after start-up as the unit should be allowed to enter the "ready" state prior to being triggered. This fault also prevents the high voltage from being fired if the microprocessor resets. For additional information, refer to the Fault Troubleshooting Section.

NOTES

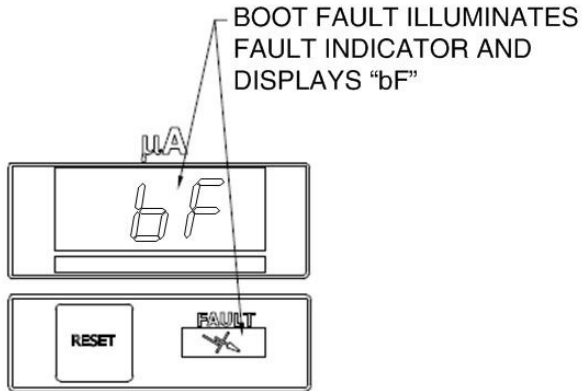

Figure 25: Boot Fault Display

MAINTENANCE

TROUBLESHOOTING GUIDE

General Problem	Possible Cause	Solution
Blank Display	<ol style="list-style-type: none"> 1. No power 2. Blown fuse 	<ol style="list-style-type: none"> 1. Check the power connections and verify they are fully connected and power is available. Power cycle the unit off and back on. 2. Check Fuses and replace if blown using the replacement fuses inside the lid of the unit.

FAULT TROUBLESHOOTING GUIDE

! WARNING

► Before troubleshooting gun and control unit problems, flush the gun with solvent and purge with air. Some of the tests will require high voltage to be applied to the gun, so the gun must be empty of paint and solvent.

Fault	Description	Solution
Cable Fault (CF)	The Cable Fault indicates the control unit does not detect a high voltage section on the end of the cable. The fault typically occurs at a high voltage trigger.	<ol style="list-style-type: none"> 1. Check for loose wiring between the pc board connector and the high voltage section by pulling on each wire. Repair if necessary. Insure both connectors are secure and re-test for CF fault. 2. Replace high voltage section or send unit in for repair. 3. Send unit in for repair.

Fault	Description	Solution
Ground Fault (GF)	The Ground Fault is typically caused by a ground connection problem, and can create a safety hazard. It can occur without high voltage and will not reset.	<ol style="list-style-type: none"> 1. Check for loose wiring between the pc board connector and the high voltage section by pulling on each wire. Repair if necessary. Insure both connectors are secure and re-test for GF fault. 2. Adjust the setpoint to 20kV and turn on the high voltage. A GF fault indicates a faulty pc board - replace. 3. Replace high voltage section or send unit in for repair. 4. Send unit in for repair.
Over-Voltage Fault (OU)	The Over Voltage Fault indicates the output voltage exceeds the design specifications. It typically occurs during a high voltage trigger.	<ol style="list-style-type: none"> 1. Check connections using two finger pull test to ensure they are connected. 2. Replace the pc board. 3. Send unit in form repair.
Over-Load Fault (OL)	The Over Load Fault indicates the current output has exceeded the overload threshold. This fault is only active if jumper 17 is shorted. The overload threshold is <u>normally</u> set at 10 μ A below the maximum output of the applicator.	<ol style="list-style-type: none"> 1. This may indicate the paint conductivity is too high (resistance too low) or the outside of the applicator is contaminated with paint.
Current Limit Fault (CL)	The Current Limit Fault indicates the current output of the gun has exceeded the maximum allowable output current. It typically occurs with the high voltage on.	<ol style="list-style-type: none"> 1. Clean outside of the applicator. 2. Replace barrel or applicator. 3. Send applicator in for repair.
Feedback Fault (FF)	The Feedback Fault indicates there is no current feedback or it is incorrect. It typically occurs with the high voltage on.	<ol style="list-style-type: none"> 1. Securely attach a ground wire to the applicator electrode. 2. Set the high voltage to maximum and place a jumper across the flow switch. 3. The current reading on the control unit should rise up to the maximum current output. If it does not, send the applicator in for repair.

Fault	Description	Solution
Voltage Cable Fault (UC)	The Voltage Feedback Fault indicates the cascade drive signal is not present. It typically occurs when high voltage is triggered.	<ol style="list-style-type: none"> 1. Turn off the voltage controller and remove the high voltage cable from the voltage controller. 2. Turn on the power and place a jumper across the flow switch. If the fault occurs, send the voltage controller in for repair. If no fault occurs, continue. 3. Either the high voltage cable or if using a hand gun, the gun resistor tube has failed.. If available, replace the high voltage cable, or continue to test the resistor tube. 4. To test the resistor tube, remove the resistor tube from the gun and inspect for signs of burning or arcing. Cracks or black marks indicate failure of the resistor tube, indicating the resistor tube must be replaced. Measure the resistance using a tri-meter connected to the black end of the tube and screwdriver in the other end. The measurement must be 150 to 170 Mega ohms. Replace resistor tube if the reading is not correct. 5. Replace high voltage cable or send applicator unit in for repair.
Boot Fault (bF)	The Boot Fault indicates that an active trigger signal was detected during the start-up sequence.	<ol style="list-style-type: none"> 1. Turn off the voltage controller. 2. Ensure that the gun trigger is not pressed. 3. Turn on the voltage controller to verify that a trigger signal is not present and that the unit enters the 'ready' state. 4. Send the voltage controller in for repair or contact technical support.

PARTS IDENTIFICATION

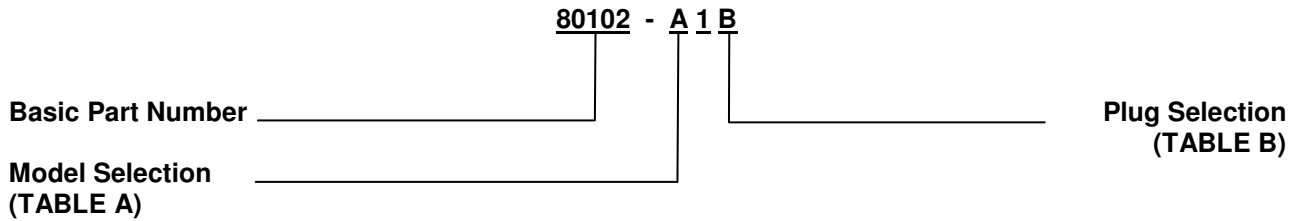

9060 HIGH VOLTAGE CONTROLLER MODEL IDENTIFICATION *

When ordering, use 80102-A1B as indicated by Table A and B. Three digits must follow the basic part number, for example:



* Model number and serial number of the voltage controller is located on the left outside face of the main enclosure.

Table A - Model Selection	
Dash No.	Description
3	No. 2 Process Gun - Air Motor

Table B - Plug Selection	
Dash No.	Description
1	Domestic 
2	European 
3	China 

9060 High Voltage Controller - Parts List	
Part #	Description
13742-02	Air Flow Switch (1.0 - 2.0 SCFM)
72771-06	Fuse (250V, 1A, 5mm x 20mm)
79390-03	9060 High Voltage Controller PC Mainboard
20988-XX	Cable Assembly, Superflex, #2 Air Motor (XX denotes cable length)
79350-01	9060 High Voltage Cascade
76434-01	Switch, Rocker (On-Off Switch)
79428-00	Power Supply, 24V (24VDC Power Supply 1PS)

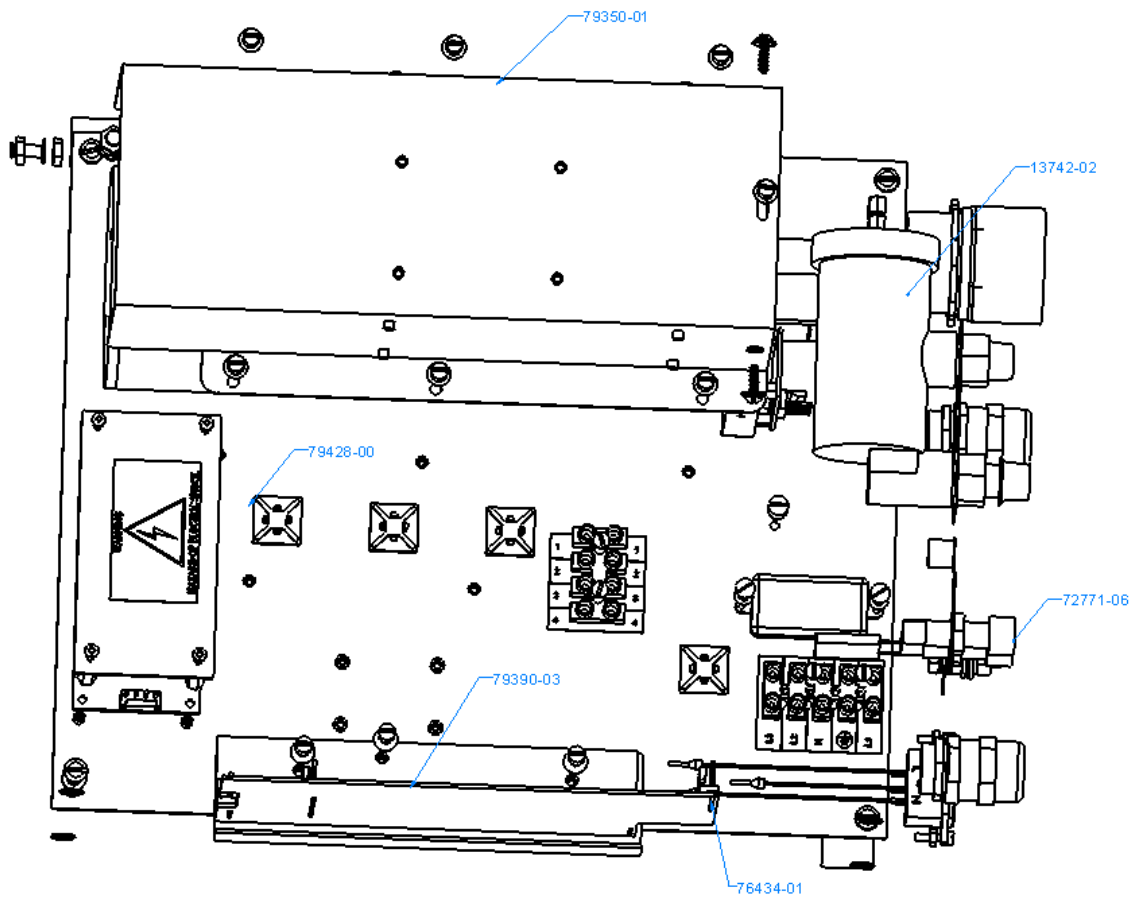

Figure 26: Part Identifications

ACCESSORIES

9060 High Voltage Controller - Accessories List	
Part #	Description
76652-01	HV Probe
76652-02	Meter w/Test Leads
76652-03	Paint Test Probe w/Meter
76652-04	Deluxe Kit (Include HV Probe, Meter w/Test Leads, and Paint Test Probe)

WARRANTY POLICIES

LIMITED WARRANTY

Ransburg will replace or repair without charge any part and/or equipment that falls within the specified time (see below) because of faulty workmanship or material, provided that the equipment has been used and maintained in accordance with Ransburg's written safety and operating instructions, and has been used under normal operating conditions. Normal wear items are excluded.

THE USE OF OTHER THAN RANSBURG APPROVED PARTS, VOID ALL WARRANTIES.

SPARE PARTS: One hundred and eighty (180) days from date of purchase, except for rebuilt parts (any part number ending in "R") for which the warranty period is ninety (90) days.

EQUIPMENT: When purchased as a complete unit, (i.e., guns, power supplies, control units, etc.), is one (1) year from date of purchase.

WRAPPING THE APPLICATOR, ASSOCIATED VALVES AND TUBING, AND SUPPORTING HARDWARE IN PLASTIC, SHRINK-WRAP, OR ANY OTHER NON-APPROVED COVERING, WILL VOID THIS WARRANTY.

RANSBURG'S ONLY OBLIGATION UNDER THIS WARRANTY IS TO REPLACE PARTS THAT HAVE FAILED BECAUSE OF FAULTY WORKMANSHIP OR MATERIALS. THERE ARE NO IMPLIED WARRANTIES NOR WARRANTIES OF EITHER MERCHANTABILITY OR FITNESS FOR A PARTICULAR PURPOSE. RANSBURG ASSUMES NO LIABILITY FOR INJURY, DAMAGE TO PROPERTY OR FOR CONSEQUENTIAL DAMAGES FOR LOSS OF GOODWILL OR PRODUCTION OR INCOME, WHICH RESULT FROM USE OR MISUSE OF THE EQUIPMENT BY PURCHASER OR OTHERS.

EXCLUSIONS:

If, in Ransburg's opinion the warranty item in question, or other items damaged by this part was improperly installed, operated or maintained, Ransburg will assume no responsibility for repair or replacement of the item or items. The purchaser, therefore will assume all responsibility for any cost of repair or replacement and service related costs if applicable.

Manufacturing

1910 North Wayne Street
Angola, Indiana 46703-9100
Telephone: 260-665-8800
Fax: 260-665-8516

Technical Service—Assistance

320 Philips Ave.
Toledo, Ohio 43612-1493
Telephone (toll free): 800-233-3366
Fax: 419-470-2233

Technical Support Representative will direct you to the appropriate telephone number for ordering Spare Parts.