

Operating instructions and spare parts list

OptiSpray AP01-E Application Pump

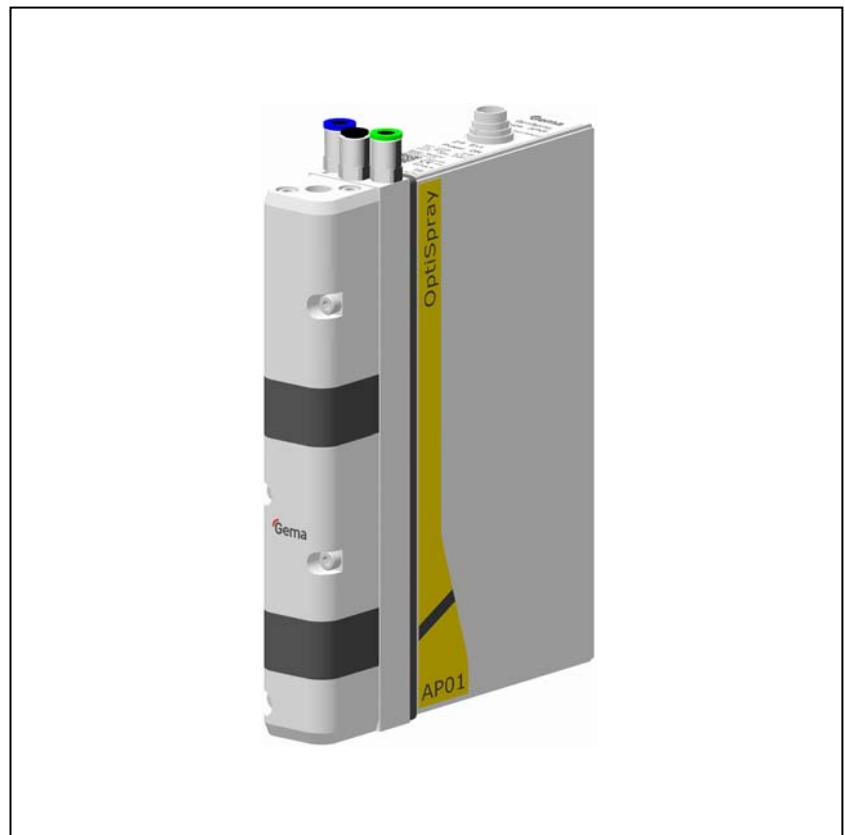

Translation of the original operating instructions

Documentation OptiSpray AP01 Application pump

© Copyright 2016 Gema Switzerland GmbH

All rights reserved.

This publication is protected by copyright. Unauthorized copying is prohibited by law. No part of this publication may be reproduced, photocopied, translated, stored on a retrieval system or transmitted in any form or by any means for any purpose, neither as a whole nor partially, without the express written consent of Gema Switzerland GmbH.

MagicCompact, MagicCylinder, MagicPlus, MagicControl, OptiFlex, OptiControl, OptiGun, OptiSelect, OptiStar and SuperCorona are registered trademarks of Gema Switzerland GmbH.

OptiFlow, OptiCenter, OptiMove, OptiSpeeder, OptiFeed, OptiSpray, OptiSieve, OptiAir, OptiPlus, OptiMaster, MultiTronic, EquiFlow, Precise Charge Control (PCC), Smart Inline Technology (SIT) and Digital Valve Control (DVC) are trademarks of Gema Switzerland GmbH.

All other product names are trademarks or registered trademarks of their respective holders.

Reference is made in this manual to different trademarks or registered trademarks. Such references do not mean that the manufacturers concerned approve of or are bound in any form by this manual. We have endeavored to retain the preferred spelling of the trademarks, and registered trademarks of the copyright holders.

To the best of our knowledge and belief, the information contained in this publication was correct and valid on the date of publication. Gema Switzerland GmbH makes no representations or warranties with respect to the contents or use of this publication, and reserves the right to revise this publication and make changes to its content without prior notice.

For the latest information about Gema products, visit www.gemapowdercoating.com.

For patent information, see www.gemapowdercoating.com/patents or www.gemapowdercoating.us/patents.

Printed in Switzerland

Gema Switzerland GmbH
Mövenstrasse 17
9015 St.Gall
Switzerland

Phone: +41-71-313 83 00

Fax.: +41-71-313 83 83

E-mail: info@gema.eu.com

Table of contents

About this instructions	3
General information	3
Keeping the Manual	3
Safety symbols (pictograms).....	3
Presentation of the contents	4
Figure references in the text	4
Safety	5
Intended use	5
Product specific security regulations	5
Product description	7
Field of application	7
OptiSpray AP01-E Application pump	7
Reasonably foreseeable misuse	8
Design and function	8
Structure.....	8
Powder hoses	9
Spraying air function / diffusers.....	9
Main functions	9
Secondary functions	10
Technical data	11
OptiSpray AP01-E Application pump	11
Powder output (guide values)	11
Electrical data	11
Pneumatic data	11
Dimensions	12
Sound pressure level	12
Rating plate	12
Start-up and operation	13
Preparation for start-up	13
Basic conditions	13
Basic information	13
Set-up.....	14
Connecting the Application pump	14
Connections	15
Pin assignment	15
Start-up	16
Configuration.....	16
Fluidized powder hopper.....	16
Characteristics	16
Conveying direction	16
Powder hose rinsing	16
Maintenance interval monitoring	17

Functional check and operation.....	17
Switching on and off the conveying procedure.....	17
Switching on and off the rinsing procedure	17
Decommissioning	18
Cleaning and maintenance	19
Cleaning the Application pump (color change).....	19
Maintenance of the dense phase pump	20
Daily maintenance	20
Pinch valve diagnostic.....	20
Maintenance schedule.....	20
Wearing parts	20
Replacing the pinch valve hoses and filter elements	21
Required spare parts	21
Required Tools	21
Pump disassembly	21
Replacing the pinch valve hoses.....	22
Replacing the filter elements	23
Replacing the Application pump in an OptiCenter	24
Troubleshooting	25
General information	25
Spare parts list	27
Ordering spare parts.....	27
Spare parts list.....	28
Spare parts	29
Connecting material.....	30
Diffusor (OptiSelect GA03-E)	31
Diffusor (OptiSelect GM03-E).....	32

About this instructions

General information

This operating manual contains all important information you will need to work with the OptiSpray AP01. It will safely guide you through the start-up process and give you references and tips for the optimal use of your new powder coating system.

Information about the functional mode of the individual system components should be referenced in the respective enclosed documents.

Keeping the Manual

Please keep this Manual ready for later use or if there should be any queries.

Safety symbols (pictograms)

The following warnings with their meanings can be found in the Gema operating instructions. The general safety precautions must also be followed as well as the regulations in the relevant operating instructions.

DANGER

Indicates a hazardous situation which, if not avoided, will result in death or serious injury.

WARNING

Indicates a hazardous situation which, if not avoided, could result in death or serious injury.

CAUTION

Indicates a hazardous situation which, if not avoided, could result in minor or moderate injury.

ATTENTION

Indicates a potentially harmful situation. If not avoided, the equipment or something in its surrounding may be damaged.

ENVIRONMENT

Indicates a potentially harmful situation which, if not avoided, may have harmful consequences for the environment.

**NOTE**

<Useful information, tips, etc.>

Presentation of the contents

Figure references in the text

Figure references are used as cross references in the descriptive text.

Example:

"The high voltage (**H**) created in the gun cascade is guided through the center electrode."

Safety

Intended use

- This product is built to the latest specification and conforms to the recognized technical safety regulations and is designed for the normal application of powder coating.
- Any other use is considered non-compliant. The manufacturer shall not be liable for damage resulting from such use; the user bears sole responsibility for such actions. If this product is to be used for other purposes or other substances outside of our guidelines then Gema Switzerland GmbH should be consulted.
- Observance of the operating, service and maintenance instructions specified by the manufacturer is also part of conformity of use. This product should only be used, maintained and started up by trained personnel, who are informed about and are familiar with the possible hazards involved.
- Start-up (i.e. the execution of intended operational tasks) is forbidden until it has been established that this product has been set up and wired according to the guidelines for machinery. The standard "Machine safety" must also be observed.
- Unauthorized modifications to the product exempt the manufacturer from any liability from resulting damage.
- The relevant accident prevention regulations, as well as other generally recognized safety regulations, occupational health and structural regulations are to be observed.
- Furthermore, the country-specific safety regulations also must be observed.

Product specific security regulations

- This product is a constituent part of the equipment and is therefore integrated in the system's safety concept.
- If it is to be used in a manner outside the scope of the safety concept, then corresponding measures must be taken.
- The installation work to be done by the customer must be carried out according to local regulations.
- It must be ensured, that all components are earthed according to the local regulations before start-up.



NOTE

For further security information, see the more detailed Gema safety regulations!

WARNING

Working without operating instructions

Working without operating instructions or with individual pages from the operating instructions may result in damage to property and personal injury if relevant safety information is not observed.

- Before working with the device, organize the required documents and read the section "Safety regulations".
 - Work should only be carried out in accordance with the instructions of the relevant documents.
 - Always work with the complete original document.
-

Product description

Field of application

OptiSpray AP01-E Application pump

The OptiSpray AP01-E Application pump is intended for conveying enamel powder to the powder gun. Any other use is considered non-compliant. The manufacturer shall not be liable for damage resulting from such use; the user bears sole responsibility for such actions.

The OptiSpray AP01-E Application pump operates only in combination with the OptiStar CG12-CP (automatic equipment) or the OptiStar CG11-P Control unit (manual equipment).

The OptiSpray AP01-E application pump will only operate in combination with the OptiGun GA03-E automatic gun or with other Gema models with a suitable diffuser (spraying air adapter). Please contact Gema if you have any further queries.



fig. 1

Reasonably foreseeable misuse

- Use with insufficient compressed air quality
- Input pressure too low

Design and function

Structure

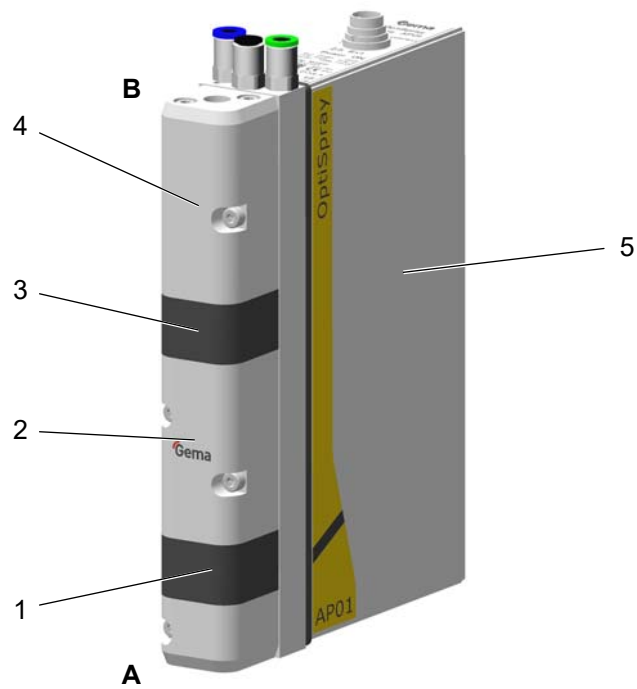

fig. 2: Structure

- | | |
|---|--|
| <p>A Suction side</p> <p>1 Pinch valve housing (suction side)</p> <p>2 Filter element bodies with filter elements (suction side)</p> | <p>B Conveyance side</p> <p>3 Pinch valve housing (transport side)</p> <p>4 Filter element bodies with filter elements (transport side)</p> <p>5 Pneumatic system and electronics</p> |
|---|--|

Powder hoses

Depending the application, different powder hoses are used for the suction and conveying procedure. The corresponding hose connections with nuts with kink protection must be used!

Field of application	Suction side	Conveyance side
In OptiCenter OC03/OC05	Inside diameter 4.5 mm OptiCenter suction tube/hose max. 30 cm	Inside diameter 7 mm
In manual equipment OptiFlex 2 Spray	Inside diameter 4.5 mm, hose length max. 1 m	Inside diameter 7 mm

NOTE

Other hose diameters can also be used for certain applications. Only use other hose diameters with the explicit recommendation of Gema!

On the transport side, a powder hose with conductive strip must be used (electrically conductive)!

Spraying air function / diffusers

The coating guns to be used must be equipped with the appropriate spraying air function or with an appropriate diffuser adapter.

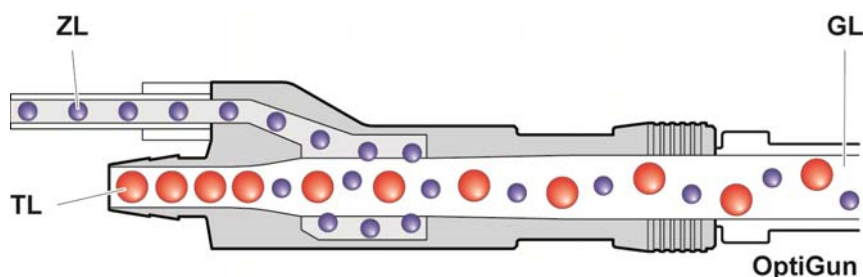

fig. 3: Air streams in the diffuser adapter

GL	Total air	TL	Transport air
ZL	Spraying air	P	Gun

The OptiGun GA02 automatic gun and the OptiSelect GM03 manual gun must also be equipped with an appropriate diffuser adapter.

The diffuser is grounded through the powder transport hose with conductive strips!

Main functions

- Conveying coating powder from or a fluidized container to the powder gun
- Processing signals from the superordinated OptiStar CG12-CP or CG11-P Control unit

Secondary functions

- Powder hose rinsing and cleaning of the filter elements



Technical data

OptiSpray AP01-E Application pump

Powder output (guide values)

OptiSpray AP01-E	
In OptiCenter: Conveying hose till 20 m – internal Ø 7 mm Suction tube/hose till 30 cm – internal Ø 4,5 mm	50-300 g/min
In manual equipment: Conveying hose till 20 m – internal Ø 7 mm Suction hose max. 1 m – internal Ø 4,5 mm	50-300 g/min

Electrical data

OptiSpray AP01-E	
Nominal input voltage	24 VDC
Output	10 VA
Protection type	IP54
Temperature range	15 °C – 40 °C (+59 °F - +104 °F)
Temperature class	T6
Approval	  II 3D

Pneumatic data

OptiSpray AP01-E	
Compressed air main connection	Quick release connection – 8 mm
Input pressure	6 bar
Max. compressed air consumption	approx. 2 Nm ³ /h
Max. water vapor content of the compressed air	1,3 g/m ³
Max. oil vapor content of the compressed air	0,1 mg/m ³

Dimensions

OptiSpray AP01-E	
Height (basic module, without connections)	264 mm
Width	40 mm
Depth	183 mm
Weight (basic module, without connections)	3,1 kg

Sound pressure level

OptiSpray AP01-E	
Normal operation	< 60 dB(A)

The sound pressure level was measured while the unit was in operation; measurements were taken at the most frequent operator positions and at a height of 1.7 m from the ground.

The specified value is applicable only for this product itself and does not take into account external noise sources or cleaning impulses.

The sound pressure level may vary, depending on the product configuration and space constraints.

Rating plate



Start-up and operation

Preparation for start-up

Basic conditions

By the start-up of the OptiSpray AP01-E Application pump, the following basic conditions, which have an influence on the powder transport, must be considered:

- Characteristic of hose layout
- Length and height difference of the suction distance – max. 30 cm
- Length of the conveying distance – 10-25 m
- Powder preparation and powder quality

Basic information

The adherence of the following principles leads to a successful start-up of the Application pump:

- The suction distance is to be kept as short as possible
- Basically, the powder transport with the Application pump works with every powder type, which can be fluidized. If the powder is for example humid or contaminated with other materials, then the conveying can be negatively influenced or does not work at all
- The OptiSpray AP01-E Application pump is not intended for use with enamel powders
- At the suction area, a homogeneous fluidization must be ensured, so that no air ducts (craters) can be formed

Set-up

The application pump can be used either in an OptiCenter OC03/OC05 Powder management center or as a part of the OptiFlex 2 Spray manual equipment.

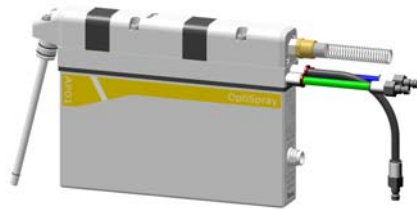

ATTENTION

Surrounding temperature too high

- Install the Application pump only in locations with an ambient temperature of between +15 and +40 °C, i.e. never next to heat sources (such as an enameling furnace) or electromagnetic sources (such as a control cabinet).

Connecting the Application pump

The OptiSpray AP01-E Application pump is supplied ready for use by the manufacturer. Just a few cables and hoses must be connected.

The connection of the OptiSpray AP01-E Application pump takes place according to following instructions:

1. Connect the control signal cable to the connection **2.5**
2. Connect the compressed air supply to the connection **1.1**
3. Connect the transport air to the connection **1.2**
4. Connect the pinch valve air to the connection **1.6**
5. Connect the powder hoses to the Application pump input and output

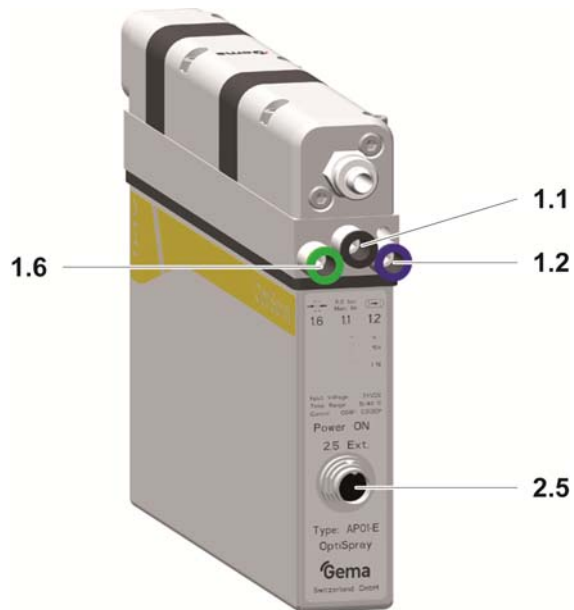

fig. 4: Connections

1.1	Compressed air (Air Supply IN)	1.6	Pinch valve air
1.2	Transport air (Conveying Air IN)	2.5	Ext. Signal

NOTE

The further start-up procedure for the OptiSpray AP01-E Application pump is explicitly described in the OptiStar CG12-CP/CG11-P Gun control unit operating instructions (chapter "Initial start-up" and "Daily start-up")!

Connections

Pin assignment

Control IN socket, 12 pins

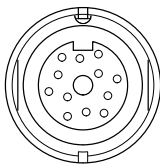

fig. 5:

A-G	Control signal
H	LED
J-M	+24 VDC
	Body - Ground

Start-up

Configuration

The start-up of the Application pump takes place according to following instructions:

1. Connect the compressed air supply to the connection **1.1** (6 bar)
2. Connect the transport air hose to the connection **1.2**
3. Connect the pinch valve air hose to the connection **1.6**
4. Connect the external signals cable to the connection **2.5**
5. Adapt the adjusting parameters for total air and powder output (see also the OptiStar CG12-CP or CG11-P operating instructions)
6. Ensure the fluidization
7. Start the pumping procedure

Fluidized powder hopper

The powder is fluidized in the powder container by fluidizing air forced through a porous plastic plate from below. Thereby, the powder becomes loose and acquires fluid-like characteristics.



NOTE

For a better understanding of the interrelationships in powder coating, it is recommended to read completely the operating instructions of the control unit and the powder gun, so as to be familiar with their functions too!

Characteristics

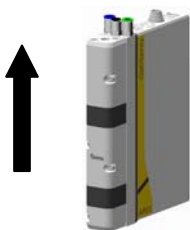

Conveying direction

The Application pump conveying direction is defined by the direction of arrow, that means, the suction side is on the bottom, the transport side on the top (see picture).

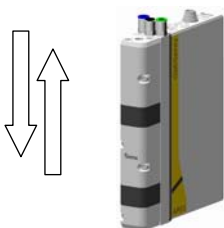

Powder hose rinsing

The powder hose rinsing enables the cleaning of the powder hoses and the filter elements in the Application pump. If color changes take place, rinsing must be done in conveying and in suction direction.

Cleaning programs

The OptiStar Gun control unit features three cleaning programs:

- Powder chamber emptying combined with hose cleaning in both directions
- Cleaning the hose to the gun only
- Cleaning the hose on the suction side only



(For details, see the operating instructions of the corresponding gun control unit)

ATTENTION

Large dust formation possible!

- The conveying hose and the powder gun must be pointed into the booth during the cleaning procedure!

The Ultra sonic sieve can be damaged during cleaning when being used with an OptiCenter.

- Only the original lid (without any sieve insert) must be assembled and closed on the OptiSpeeder!

The pump is to be cleaned as a component of the entire system.

Maintenance interval monitoring

This function is provided by the OptiStar CG12-CP or the CG11-P Control unit.

Functional check and operation



NOTE

During the assembly or the first start-up, it is recommended to carry out the functional check without powder!

Switching on and off the conveying procedure

The conveying procedure is switched on and off by the Control unit (see the corresponding operating manual).

Switching on and off the rinsing procedure

The rinsing procedure is switched on and off by the Control unit (see the corresponding operating manual).

Decommissioning

The Application pump is switched off by the control unit.

The compressed air supply to the Application pump must also be interrupted!

Cleaning and maintenance



NOTE

Regular and conscientious maintenance increases the service life of the OptiSpray AP01-E Application pump and ensures a longer, more constant coating quality!

- The parts to be replaced during maintenance work are available as spare parts. These parts can be found in the corresponding spare parts list!
-

Cleaning the Application pump (color change)

For the preparation of a color change, the pump has to be rinsed.



NOTE

The rinsing procedure can be started and stopped only externally via control unit or plant control.

- The Application pump must be cleaned at least once per shift!
-

Maintenance of the dense phase pump

The OptiSpray AP01-E Application pump is designed in such a way, that only a minimum maintenance is required.

Daily maintenance

Clean the Application pump with a dry cloth and check the connection points of the powder hoses. Replace the powder hoses, if necessary.

Rinse the Application pump by using the rinsing program. Therewith, the filter elements are cleaned and possible, unintended powder deposits in the Application pump and in the powder hoses are avoided.

Pinch valve diagnostic

The pinch valve diagnostic is to be carried out, in order to maintain the coating quality or after the error message **H89** is displayed.

The prerequisites for the diagnostic:

- Exhaust at suction and conveyance side must be present and in operation
- Powder hopper must be empty
- Cleaning program completed



NOTE

The pinch valve diagnostic is to start after the cleaning program has been completed!

- The detailed procedure is explicitly described in the CG12-CP/CG11-P Gun control unit operating instructions!

If the error message **H87/H187** (suction pinch valve) or **H88/H188** (conveying pinch valve) is displayed after the procedure has been completed, the corresponding pinch valve hoses must be replaced – see below.

Maintenance schedule

The following components or modules are subject to a maintenance plan:

- Pinch valves
- Filter elements

The service life of the filter elements and pinch valves depends on the service duration, the powder quality and the quality of the air supply.

Wearing parts

The wearing parts to be replaced during the OptiSpray AP01-E Application pump maintenance are available separately (see spare parts list).

Replacing the pinch valve hoses and filter elements



NOTE

Before dismantling/changing the filter elements, it is necessary to clean the Application pump in both directions by using the rinsing program!

Required spare parts

AP01-E Service set

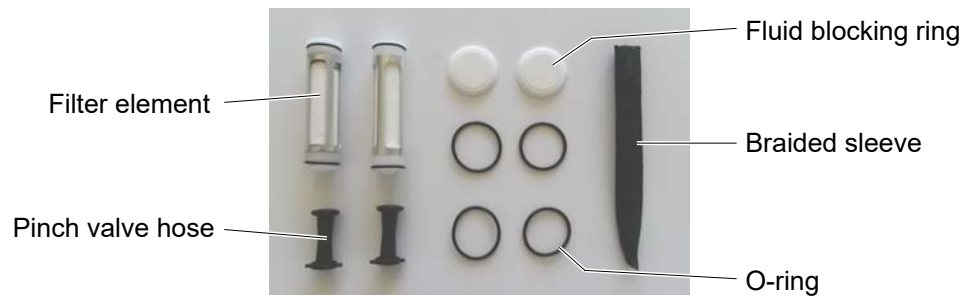

Required Tools



Pump disassembly

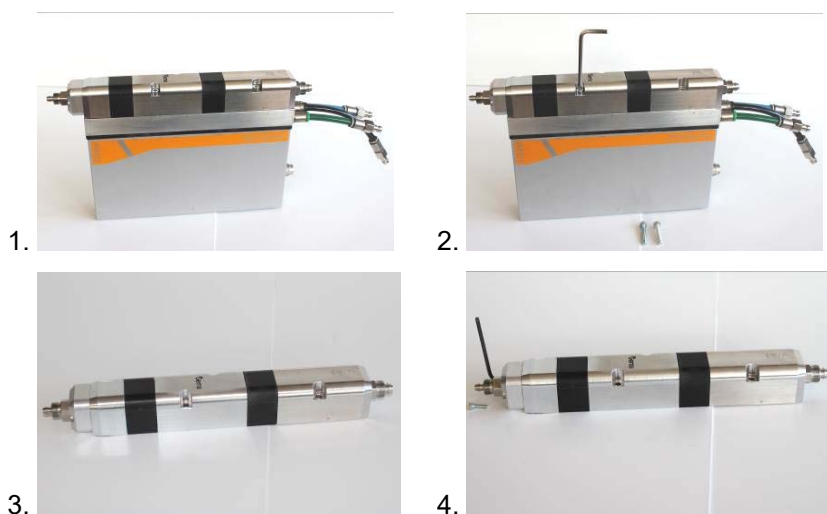

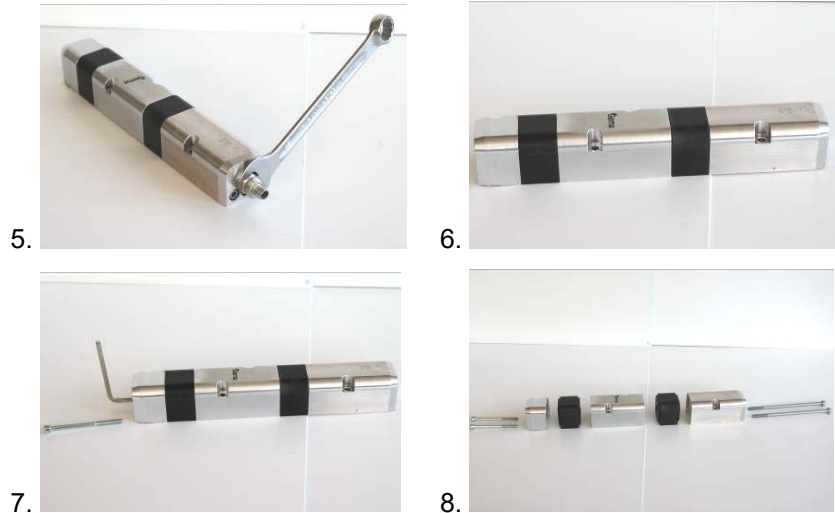

Replacing the pinch valve hoses

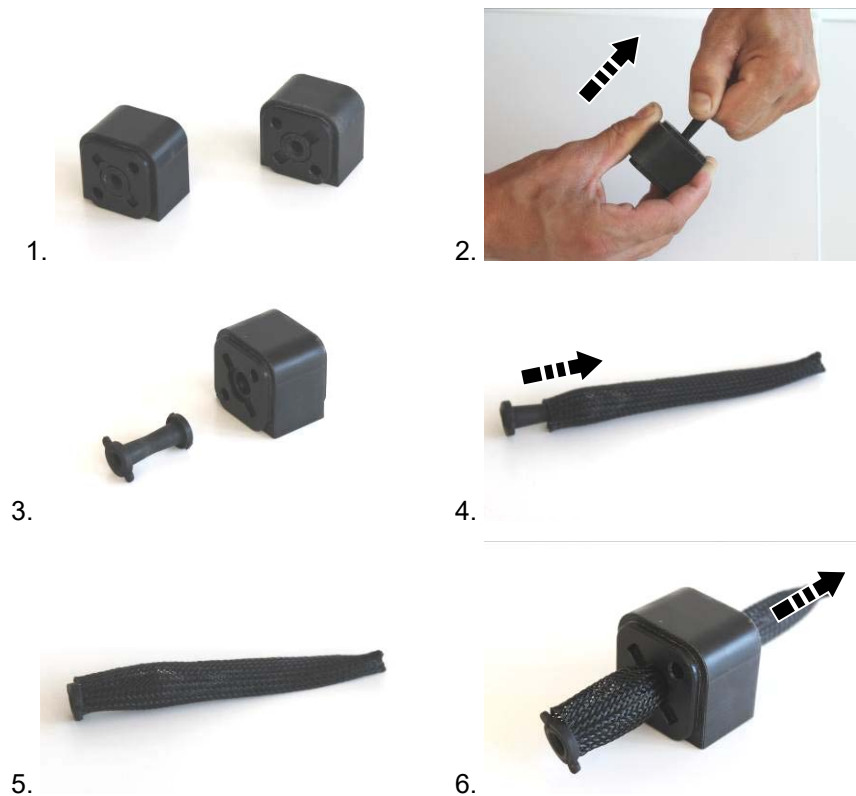

ATTENTION

Incorrect inserted pinch valve hose causes malfunctions

- It is imperative to consider the position of the lens-shaped opening!
- Make sure that the positioning tabs are set correctly!

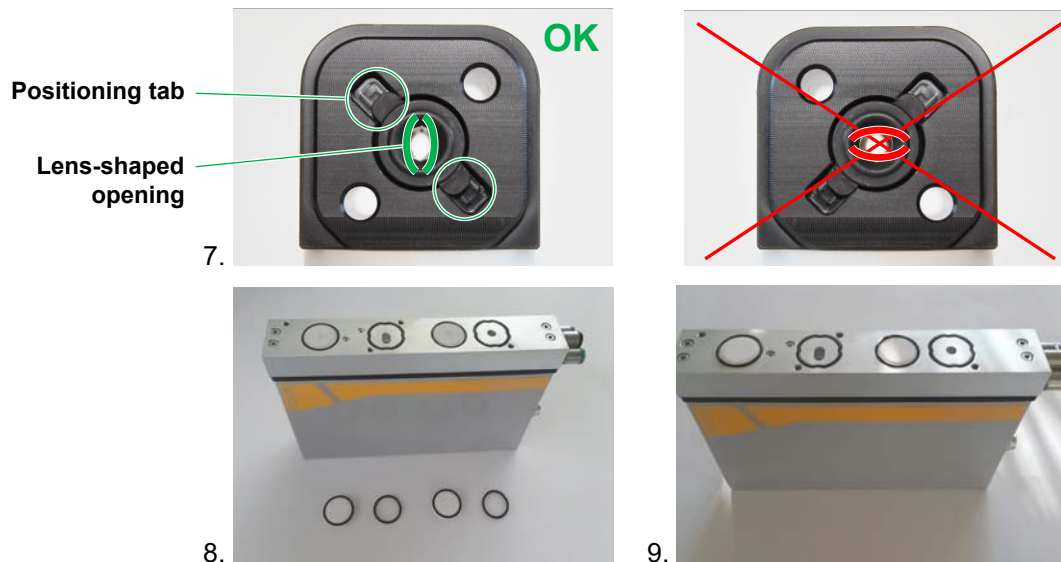

ATTENTION

Broken pinch valve hose may cause the clogging of the fluid blocking plate

- Clean or replace the corresponding fluid blocking plate!

Replacing the filter elements

ATTENTION

Use of non-permissible cleaning agents may cause damage to the plastic pinch valve body

- When cleaning the pinch valve bodies, do not use alcohol, acetone, benzol or other solvents!
- For cleaning, use benzine, light lye or acid or a cleaning agent!

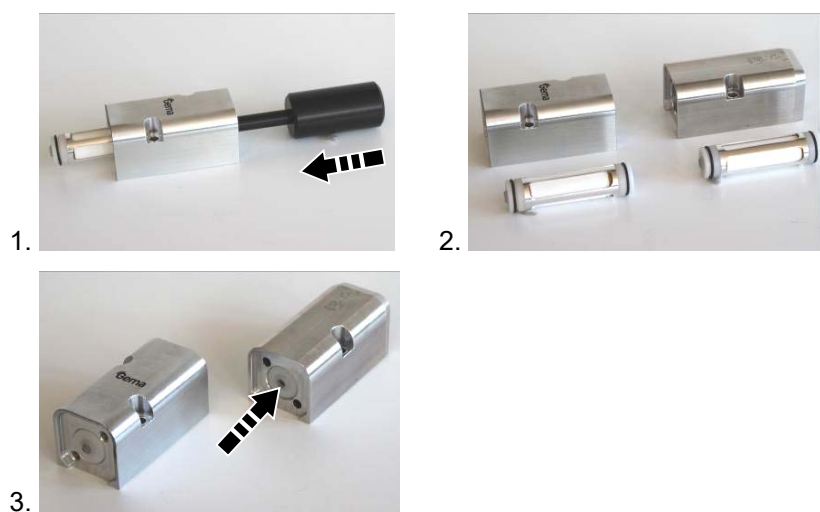

ATTENTION

Incorrectly assembled parts may cause malfunctions or defects

- The assembly takes place in reverse order!
- The tightening torques are to be observed, when assembling!
- The process zone has to be pressed against a planar surface and assembled on it!

WARNING

Tightening torque: 4.4 Nm

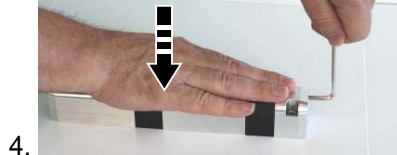

4.



5.



6.



WARNING

Tightening torque: 3.5 Nm

7.

NOTE

The AP01-E Application pump should be operated with powder at least 1/2 hour after replacing the filter elements.

- After the running-in of the filter elements a stable powder output value will be reached.

Replacing the Application pump in an OptiCenter

1. Remove the powder from the system
2. Start the cleaning program, rinse in both directions
3. Depressurize/vent OptiCenter
4. Next steps are described in the corresponding OptiCenters operating manual

Troubleshooting

General information

Fault	Causes	Troubleshooting
Application pump does not convey	No control signal	Check the control cable
	Compressed air supply failed or pressure too low	Check the compressed air source (ensure an air pressure of 7-10 bar), check the pressure gauge of the local pressure regulator
	No transport air present	Check the hose connection of the control unit to the Application pump Check the compressed air supply
	No fluidization in the suction zone	Ensure the fluidization
	Service life of the pinch valve has expired (defective)	Change the pinch valve, check the pneumatic system for defects and replace, if necessary
	Service life of the filter element runs off (clogged)	Replace the filter element
Application pump conveys irregularly or too little powder	Pinholing in the powder container, powder will not be fluidized well	Adjust the fluidization correctly
	Hose backpressure is larger than 1.2 bar	Powder hose is too long or too thin Powder hose is clogged or bend (clean or replace it) Filter elements (filter chamber/pinch valve hose) are clogged (clean or replace them)
	Filter elements tend to clogging	Run the rinsing program, replace the filter elements
	Powder hoses tend to clogging due to sintering	Clean or replace the powder hoses

Fault	Causes	Troubleshooting
	Oil or water in the system	Ensure that oil or water will be separated before entering into the Application pump
	Transport air offset C3 not adapted to powder output	Adapt transport air offset C3 (see operating manual OptiStar CG12-CP or CG11-P, section "Correction values")

Spare parts list

Ordering spare parts

When ordering spare parts for powder coating equipment, please indicate the following specifications:

- Type and serial number of your powder coating equipment
- Order number, quantity and description of each spare part

Example:

- **Typ** OptiSpray AP01,
Serial number 1234 5678
- **Order no.** 203 386, 1 piece, Clamp – Ø 18/15 mm

When ordering cable or hose material, the required length must also be given. The spare part numbers of this bulk stock is always marked with an *.

Wearing parts are always marked with a #.

All dimensions of plastic hoses are specified with the external and internal diameter:

Example:

Ø 8/6 mm, 8 mm outside diameter (o/d) / 6 mm inside diameter (i/d)

ATTENTION

Use of non-original Gema spare parts

When using the spare parts from other manufacturers the explosion protection is no longer guaranteed. If any damage is caused by this use all guarantee claims become invalid!

- Only original Gema spare parts should be used!
-

Spare parts list

	OptiSpray AP01-E Application pump – complete (pos. 1-14)	1013 293
1	Allen cylinder screw – M5x120 mm	1010 369
2	Upper end piece	1010 049
3	Filter element – 3 µm, 10 mm, complete (incl. pos. 3.1)	1013 287#
3.1	O-ring – Ø 16x1.5 mm	205 141#
4	Allen cylinder screw – M5x35 mm	1005 185
5	Filter element body	1010 046
6	Pinch valve hose – DN5	1009 311#
6.1	Braided sleeve – fit-up aid kit for pos. 6 (not shown)	1005 270
7	Allen cylinder screw – M5x65 mm	244 759
8	Lower end piece	1013 289
9	Pinch valve housing	1010 047
11	Fluid blocking ring	1010 354#
12	O-ring – Ø 26x2 mm	246 549#
13	Valves assembly – complete (without pos. 14)	1010 305
14	Body – complete (for pos. 13)	1013 309
15	Nut with kink protection – M16x1-Ø 12 mm	1005 443
16	Elbow connection	1013 313
17	Allen cylinder screw – M5x20 mm	222 950
18	Allen cylinder screw – M4x12 mm	216 275
19	O-ring – Ø 10x2 mm	243 000#
20	Plug	1013 315
21	O-ring – Ø 16x2 mm	1007 794#
22	Suction tube	1013 317
23	O-ring – Ø 6.1 mm	217 115#
24	Hose connection – Ø 11.5/7 mm	1013 297
25	Screw-in nipple – 1/8"-Ø 8 mm	1010 378
26	Connection/plug	200 859
27	O-ring – Ø 8x1 mm	1007 793#
30	Powder hose suction side – Ø 4.5 mm (not shown)	1005 454*
31	Powder hose transport side – Ø 10/7 mm (not shown)	1017 592*
32	Plastic tube – Ø 8/6 mm, blue	103 497*
33	Plastic tube – Ø 8/6 mm, black	103 152*
34	Plastic tube – Ø 8/6 mm, green	103 519*
40	Hose connection – Ø 8.1/4.5 mm	1013 299
41	O-ring – Ø 8x1.5 mm	248 878#
42	Adaptor	1013 295
43	Nut with kink protection – M12x1-Ø 8 mm	201 316
44	Maintenance set – pos. 3 (2x), pos. 6 (2x), pos. 6.1 (1x), pos. 11 (2x), pos. 12 (4x)	1014 351

* Please indicate length

Wearing part

Spare parts

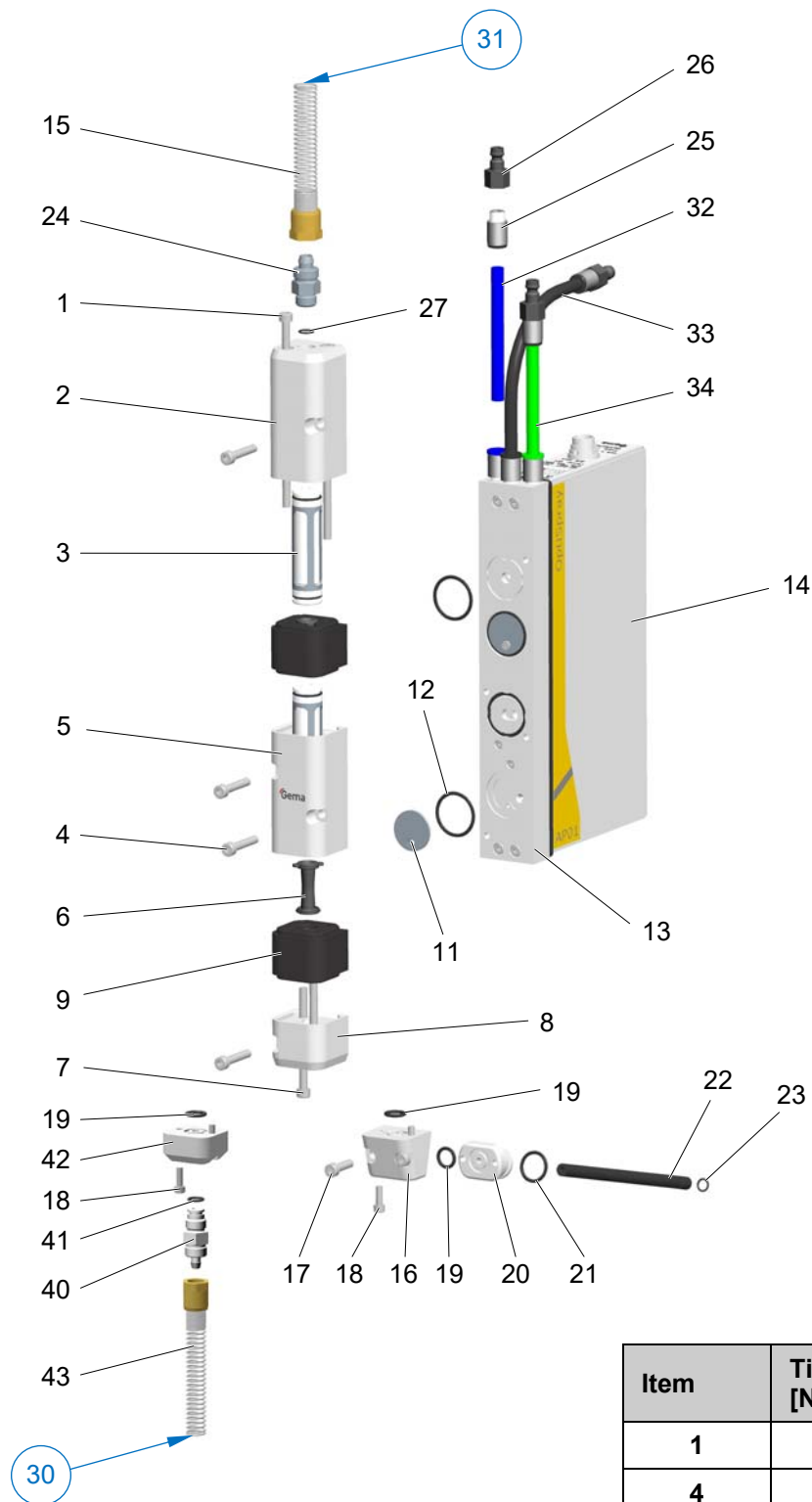

fig. 6: Spare parts

Item	Tightening torque [Nm]
1	4.4 (greased)
4	3.1 (greased)
7	4.4 (greased)
17	3,1
18	0,5

Connecting material

1.1	Plastic tube – Ø 8/6 mm, black	103 152*
1.2	Plastic tube – Ø 8/6 mm, blue	103 497*
1.6	Plastic tube – Ø 8/6 mm, green	103 519*
2.5	Connecting cable – 12 pins, 1.5 m	1000 991
	Connecting cable – 12 pins, 2.2 m	393 398
	Connecting cable – 12 pins, 5 m	1000 975
	Connecting cable – 12 pins, 10 m	1000 976
	Connecting cable – 12 pins, 15 m	1000 977
	Connecting cable – 12 pins, 20 m	1000 978

* Please indicate length

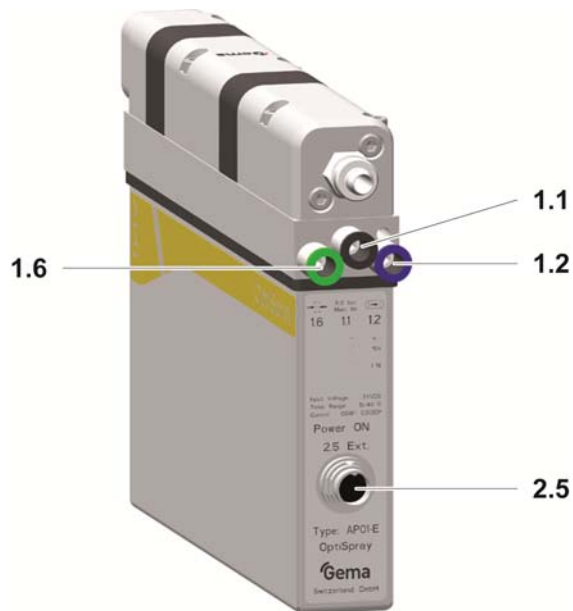

fig. 7: Connecting material

Diffusor (OptiSelect GA03-E)

	Diffusor – complete	1011 630
1	Plug-in connector – Ø 6-Ø 8 mm	254 894
2	Plastic tube – Ø 6/4 mm	103 144*
3	Screw-in nipple – M7-Ø 6 mm	1008 699
4	Connector	1011 625
5	Fluidizing tube	1005 262#
6	O-ring – Ø 13x1,5 mm	1009 943
8	Adaptor piece – complete, incl. pos. 6	1011 626

* Please indicate length

Wearing part

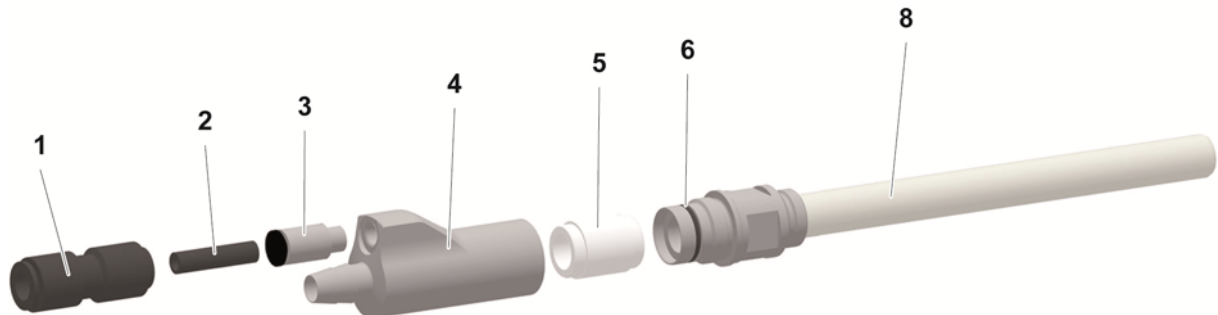

fig. 8: Diffusor (OptiSelect GA03-E)

Diffusor (OptiSelect GM03-E)

	Diffusor – complete	1011 631
1	Plug-in connector – Ø 6-Ø 8 mm	254 894
2	Plastic tube – Ø 6/4 mm	103 144*
3	Screw-in nipple – M7-Ø 6 mm	1008 699
4	Connector	1011 627
5	Fluidizing tube	1005 262#
6	O-ring – Ø 13x1,5 mm	1009 943
7	O-ring – Ø 12x1,5 mm	1000 822
8	Adaptor piece – complete, incl. pos. 6 and 7	1011 626

* Please indicate length

Wearing part

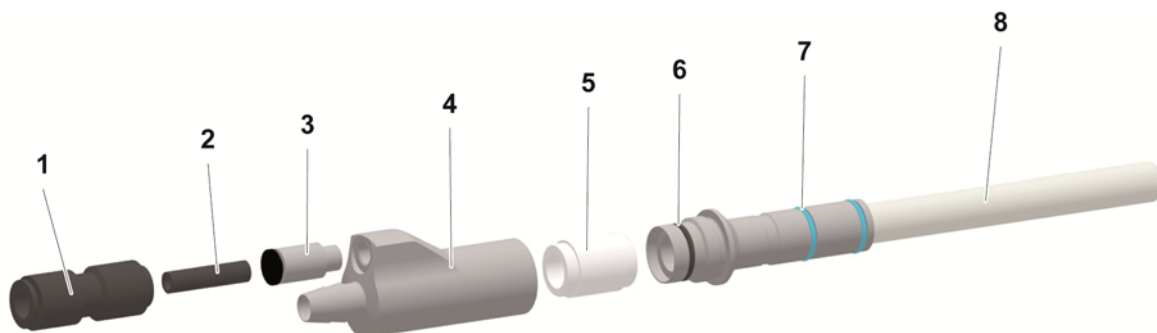

fig. 9: Diffusor (OptiSelect GM03-E)

