

---

Operating instructions and spare parts list

# OptiFlow powder injector (IG02 type)

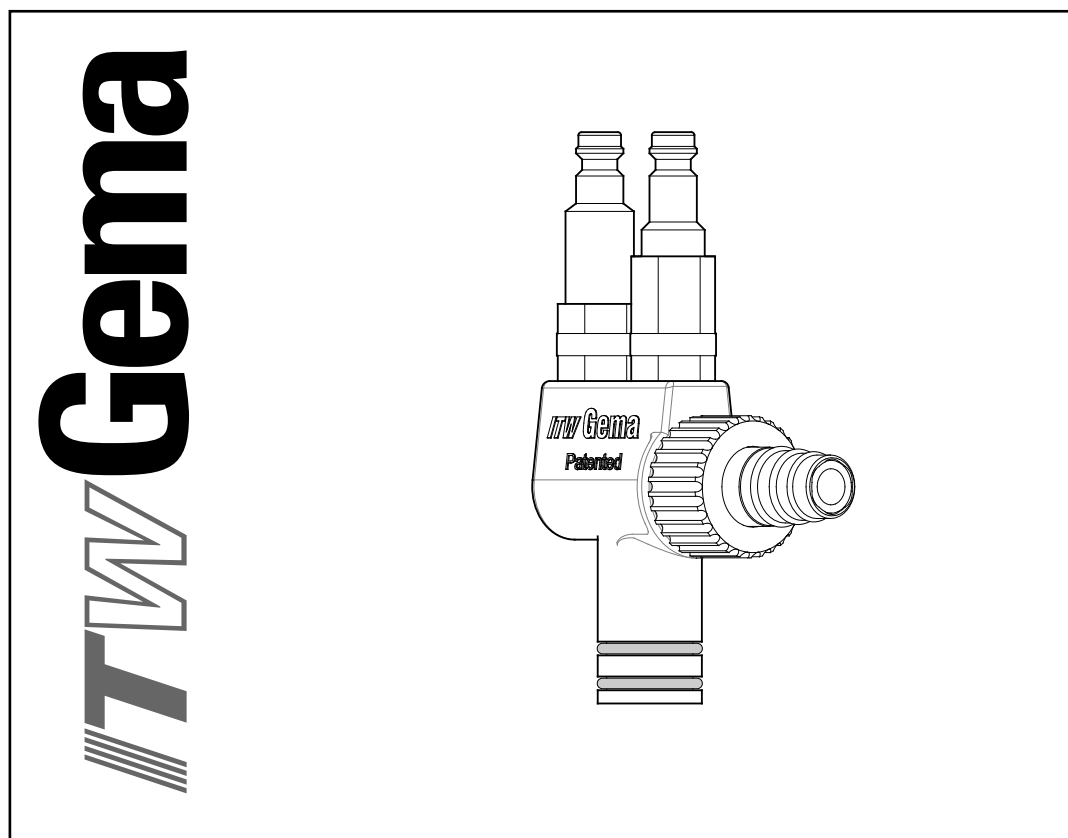

**Documentation OptiFlow powder injector (IG02 type)**

© Copyright 2004 ITW Gema AG

All rights reserved.

This publication is protected by copyright. Unauthorized copying is prohibited by law. No part of this publication may be reproduced, photocopied, translated, stored on a retrieval system or transmitted in any form or by any means for any purpose, neither as a whole nor partially, without the express written consent of ITW Gema AG.

OptiTronic, OptiGun, EasyTronic, EasySelect, EasyFlow and Super-Corona are registered trademarks of ITW Gema AG.

OptiMatic, OptiMove, OptiMaster, OptiPlus, MultiTronic and Gematic are trademarks of ITW Gema AG.

All other product names are trademarks or registered trademarks of their respective holders.

Reference is made in this manual to different trademarks or registered trademarks. Such references do not mean that the manufacturers concerned approve of or are bound in any form by this manual. We have endeavored to retain the preferred spelling of the trademarks, and registered trademarks of the copyright holders.

To the best of our knowledge and belief, the information contained in this publication was correct and valid on the date of issue. ITW Gema AG makes no representations or warranties with respect to the contents or use of this publication, and reserves the right to revise this publication and make changes to its content without prior notice.

**Printed in Switzerland**

ITW Gema AG  
Mövenstrasse 17  
9015 St. Gallen  
Switzerland

Phone: +41-71-313 83 00  
Fax.: +41-71-313 83 83

E-Mail: [info@itwgema.ch](mailto:info@itwgema.ch)  
Homepage: [www.itwgema.ch](http://www.itwgema.ch)

# Table of contents

<b>OptiFlow plug-in injector for organic powders</b>	<b>3</b>
Field of application .....	3
Principle of the injector and influence of supplementary air .....	4
Powder volume setting table for OptiFlow injector.....	5
General conditions for the OptiFlow injector.....	5
Guide values for OptiStar/OptiTronic with OptiFlow injector .....	5
<b>Cleaning and maintenance</b>	<b>7</b>
Injector cleaning .....	7
Cleaning the check valves .....	8
<b>Troubleshooting guide</b>	<b>9</b>
Problem fixing .....	9
<b>Spare parts list</b>	<b>11</b>
Ordering spare parts .....	11
OptiFlow powder injector (IG02 type) - spare parts list.....	12



# OptiFlow plug-in injector for organic powders

---

## Field of application

The OptiFlow injector is used to convey normal organic powders between the powder hopper and the powder gun. The injector is supplied with a Teflon insert sleeve as standard.

The OptiFlow plug-in injector allows fast cleaning and easy handling because it can be detached from the powder hopper without using any tools. All connections are plug-in and not interchangeable (when using in manual equipment).

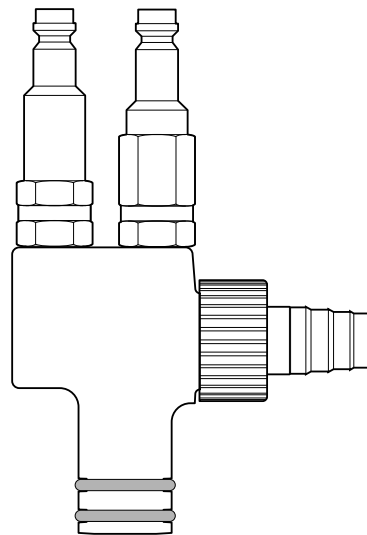

*OptiFlow powder injector (IG02 type) with coded quick-release connections*

## Principle of the injector and influence of supplementary air

If air flows through the nozzle into the cavity, a vacuum is created in the cavity (see figure below). This vacuum causes powder to be drawn up the suction tube and into the cavity. A powder/air mixture is created. The forward air velocity at the nozzle conveys the powder/air mixture through the powder hose to the gun.

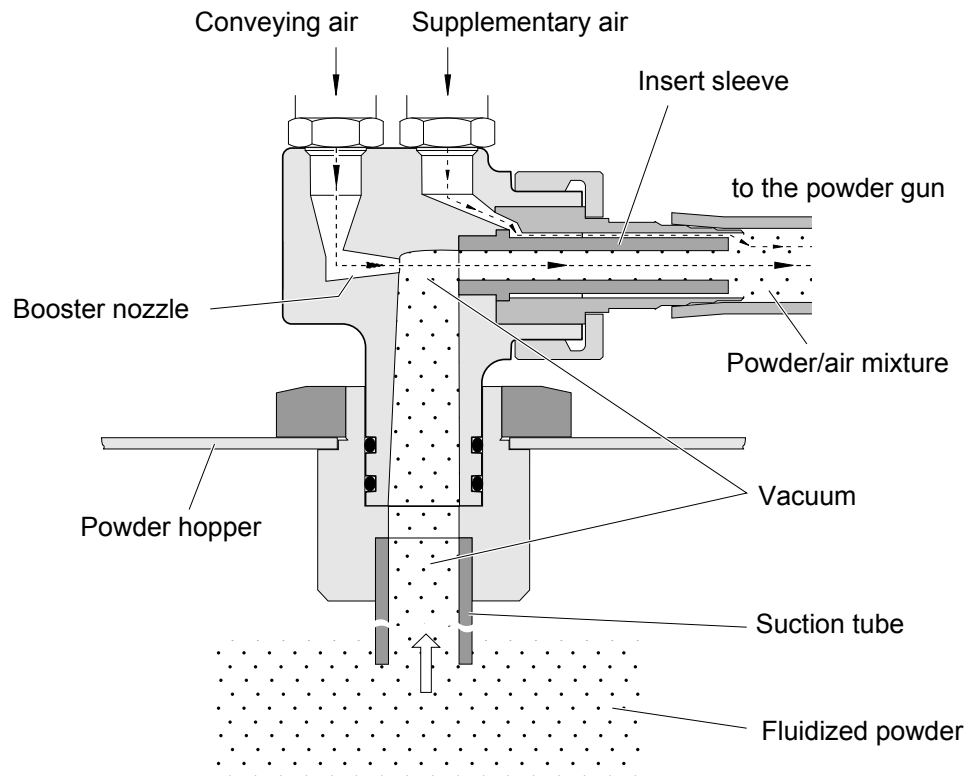

The concentration of the powder/air mixture, and with it, the powder output depends on the conveying air pressure and supplementary air pressure, the quality of the powder, the length of the powder hose, the diameter of the powder hose, the number of coils in the hose, the difference in the height between the gun and injector, and the type of nozzle. The condition of the insert sleeve is of great importance, because wear causes the powder output to sink drastically.

Experience with pneumatic material handling technology shows that pneumatic transport of fine solid matter (powder) in the form of tubing (hose) the transporting medium requires a certain volume of air per unit of time. If a  $\varnothing$  11 mm hose is used, this value is approximately 4 m<sup>3</sup>/h. To decrease the powder output, the vacuum in the cavity has to be reduced. For that purpose, the pressure of the conveying air is also reduced. With the reduction of the conveying air the volume of air in the powder hose sinks to below the optimum value of 4 m<sup>3</sup>/h. The powder transport becomes irregular, so-called "pumping" takes place. In order to prevent this from happening supplementary air is added until the volume of the air in the powder hose is 4-5 m<sup>3</sup>/h once more. This takes place fully automatically with the OptiTronic control unit.

## Powder volume setting table for OptiFlow injector

OptiStar



OptiTronic



In order to set the ideal powder volume on the OptiStar/OptiTronic, it is recommended to select the firmness of the powder cloud or the total air first. As a guide value for different powder hoses, the following values can be assumed:

- Powder hose 1004, internal Ø 11 mm, **4-5 m<sup>3</sup>/h**
- Powder hose 1005, internal Ø 12 mm, **5-6 m<sup>3</sup>/h**

According to the prevailing conditions (powder, powder hose layout, the parts to be coated) a low to lowest total air can also be set with the standard hose 1004 Ø 11 mm.

If a very large powder output is required, it is recommended to select a larger powder hose inside diameter (12 mm i/d).



### Note:

**It should be considered, that by irregular or pumping conveying, normally the total air is set too low!**

## General conditions for the OptiFlow injector

Powder type	Epoxy/Polyester
Powder hose length (m)	10
Powder hose Ø (mm)	11
Input pressure (bar)	5,0
Conveying air nozzle Ø (mm)	1,6
Supplementary air nozzle Ø (mm)	1,4

## Guide values for OptiStar/OptiTronic with OptiFlow injector

All values in these tables are guide values. Differing environmental conditions, wear and different powder types can change the table values.

OptiStar

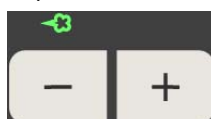

OptiTronic



Total air	Powder output (g/min)			
	4 Nm <sup>3</sup> /h	5 Nm <sup>3</sup> /h	6 Nm <sup>3</sup> /h	
Powder output  (%)	10	30	35	45
20	60	75	90	
30	85	100	120	
40	110	130	150	
50	130	160	175	
60	150	180	210	
70	175	200	235	
80	200	240	270	
90	215	260		
100	235	290		





# Cleaning and maintenance

## Injector cleaning

Cleaning should be done daily before starting work or at color change:

1. Remove the injector from the hopper
2. Pull powder hose off the hose fitting (4)
3. Clean the hose fitting (4) with compressed air which is free of water and oil and check for wear
4. Clean injector body (1) with compressed air which is free of water and oil. Any contamination can be seen through the opening of the powder hopper fitting (2)
5. Reassemble the injector and fit it on the hopper



### Attention:

**If the injector is severely contaminated, it must be dismantled! Remove the check valves (6 and 7) with the correct sized spanner. Clean the parts with compressed air and, if necessary, dissolve sintered deposits with nitro-thinners! Don't use acetone, don't scrape!**

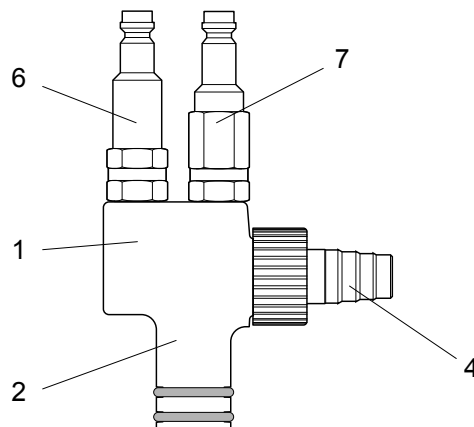

- |   |                          |   |                                 |
|---|--------------------------|---|---------------------------------|
| 1 | Injector body            | 6 | Check valve (conveying air)     |
| 2 | Powder hopper connection | 7 | Check valve (supplementary air) |
| 4 | Powder hose connection   |   |                                 |

## Cleaning the check valves



**Note:**

**Take care by dismantling the check valve, because the ball/spring can easily be lost!**

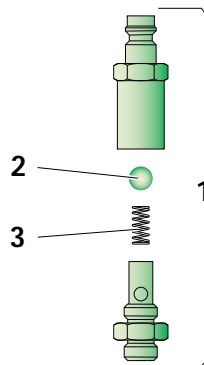

- 1 Check valve
- 2 Ball
- 3 Spring



**Note:**

**Do not immerse the ball in solvent!**

The OptiFlow injector should be cleaned once daily as a minimum! Normally, it is sufficient to clean as described on the previous page.

The injector should be dismantled completely once a week or in the case of heavy contamination (see also the figure in the spare parts list).

# Troubleshooting guide

---

## Problem fixing

The injector could be dirty or clogged, if the powder gun does not spray powder in spite of the control unit being switched on.

<b>Error/cause</b>	<b>Repair</b>
Injector nozzle, check valve, powder hose or powder gun are clogged	Clean corresponding part, if necessary replace
Too little conveying vacuum	Increase the powder volume and/or total air volume on the control unit
Insert sleeve worn or not inserted	Replace or fit the insert nozzle



# Spare parts list

---

## Ordering spare parts

When ordering spare parts for powder coating equipment, please indicate the following specifications:

- Type and serial number of your powder coating equipment
- Order number, quantity and description of each spare part

**Example:**

- **Type** OptiFlow powder injector (IG02 type)  
**Serial number** 1234 5678
- **Order no.** 203 386, 1 piece, Clamp - Ø 18/15 mm

When ordering cable or hose material, the required length must also be given. The spare part numbers of this yard/meter ware is always marked with an \*.

The wear parts are always marked with a #.

All dimensions of plastic hoses are specified with the external and internal diameter:

**Example:**

Ø 8/6 mm, 8 mm outside diameter (o/d) / 6 mm inside diameter (i/d)



---

**WARNING!**

**Only original ITW Gema spare parts should be used, because the hazardous location approval will be preserved that way! The use of spare parts from other manufacturers will invalidate the ITW Gema guarantee conditions!**

---

## OptiFlow powder injector (IG02 type) - spare parts list

	<b>OptiFlow powder injector (complete, pos. 1-9)</b>	<b>391 530</b>
1	Injector body (without pos. 2)	1000 132
2	O-ring - Ø 16x2 mm	231 517#
3	Insert sleeve - Teflon	377 724#
4	Hose connection (complete, incl. pos. 4.1)	387 827
4.1	O-ring - Ø 15x1 mm	266 930#
5	Threaded sleeve	387 819
6	Check valve conveying air (red marking) - complete (incl. pos. 8 and 9)	261 211
7	Check valve supplementary air (black marking) - complete (incl. pos. 8 and 9)	261 203
8	Ball	240 168
9	Spring	240 176
14	Quick release coupling red for conveying air hose - Ø 8/6 mm	261 645
15	Quick release coupling for supplementary air hose - Ø 8/6 mm	261 637
16	Conveying air hose - Ø 8/6 mm (red)	103 500*
17	Supplementary air hose - Ø 8/6 mm (black)	103 756*
18	Quick release coupling for hose - Ø 8/6 mm	203 181
	Powder hose - type 1001, PUR, Ø 16/11 mm (standard for automatic guns)	103 012*#
	Powder hose - type 1004, PVC, Ø 16/11 mm (standard for manual equipment)	103 128*#
	Powder hose - type 1005, PVC, Ø 20/12 mm (for manual equipment)	100 080*#
	Powder hose - type 66, POE, Ø 16/11 mm, with conductive strip (for automatic guns)	105 139*#
	Powder hose - type 74, POE, Ø 15/10 mm, with conductive strip (for automatic guns)	1001 673*#
	Powder hose - type 75, POE, Ø 18/12 mm, with conductive strip (for automatic guns)	1001 674*#

# Wearing part

\* Please indicate length

# OptiFlow powder injector (IG02 type) - spare parts

## Automatic equipment

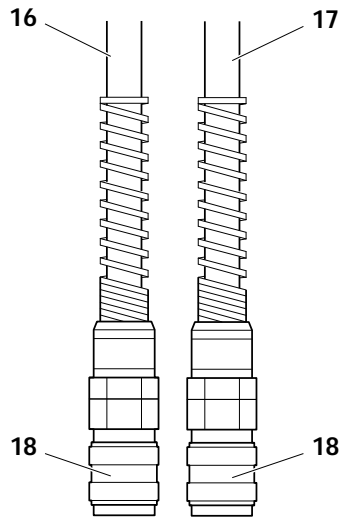

## Manual equipment

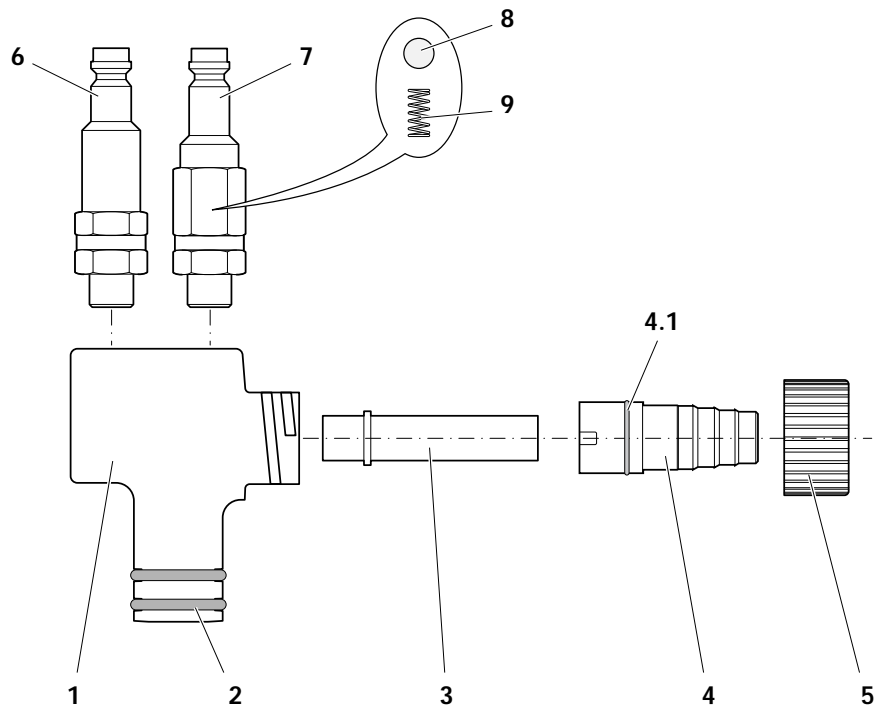
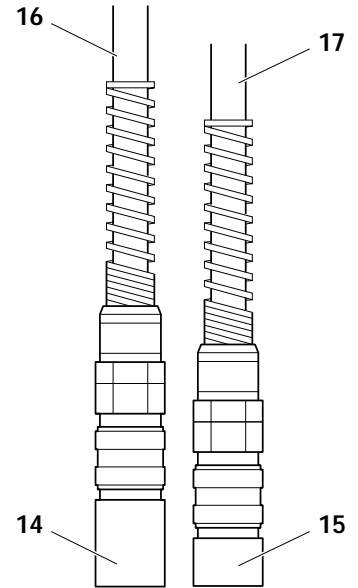

OptiFlow powder injector (IG02 type) - spare parts