

MCV ² COLLET SERIES DUAL PURGE COLOR CHANGER

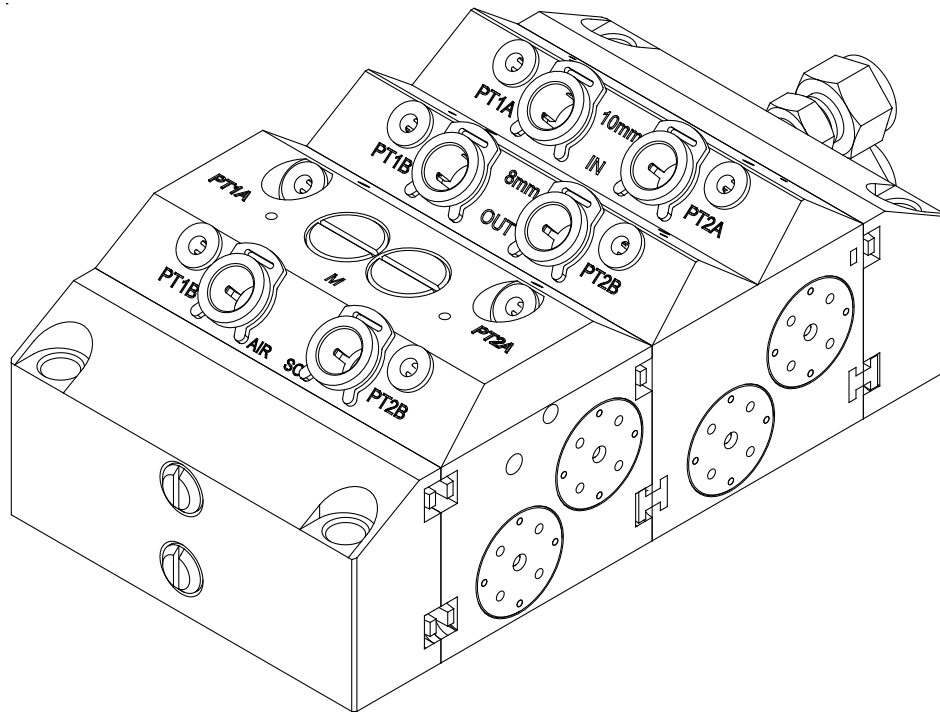

MODELS: A10986-XX - English
A10993-XX - Metric



IMPORTANT: Before using this equipment, carefully read **SAFETY PRECAUTIONS**, starting on page 1, and all instructions in this manual. Keep this Service Manual for future reference.

Service Manual Price: \$30.00 (U.S.)

NOTE: This manual has been changed from **CS-05-01.8** to revision **CS-05-01.9**. Reasons for this change are noted under “Manual Change Summary” on page 29 of this manual.

CONTENTS

	PAGE
SAFETY:	1-5
SAFETY PRECAUTIONS	1
HAZARDS / SAFEGUARDS	2-5
INTRODUCTION:	6-10
DESCRIPTIONS / SPECIFICATIONS	6
A10986-AA PRE-ENGINEERED DUAL PURGE ASSEMBLIES (ENGLISH) / PARTS LIST	7-8
A10986-AA PRE-ENGINEERED DUAL PURGE ASSEMBLIES MODEL IDENTIFICATION (ENGLISH)	8
A10993-XX PRE-ENGINEERED DUAL PURGE ASSEMBLIES (METRIC) / PARTS LIST	9-10
A10993-XX PRE-ENGINEERED DUAL PURGE ASSEMBLIES MODEL IDENTIFICATION (METRIC)	10
INSTALLATION:	11-12
MCV INSTALLATION PROCEDURES	11-12
OPERATION:	13-14
OPERATING INSTRUCTIONS	13
DIMENSIONS - METRIC (FRACTION) AND PROPOSED HOOK-UP FOR 2 COLORS	14
MAINTENANCE:	15-19
GENERAL MAINTENANCE	15-17
REMOVING AND REINSTALLING A VALVE BLOCK FROM A STACK	17
TEST AND CHECKOUT PROCEDURE FOR COLOR CHANGER	18-19
PARTS IDENTIFICATION:	20-52
A10986-AA (ENGLISH) AND A10993-XX (METRIC) DUAL PURGE ASSEMBLIES / PARTS LIST	20-21
A10993-XX DUAL PURGE ASSEMBLY (METRIC) / PARTS LIST	21
A10984 (ENGLISH) AND A10992 (METRIC) DUAL PURGE SOLVENT / AIR ASSEMBLY / PARTS LIST	22-23
A10981 DUAL PURGE CIRCULATING ASSEMBLY (ENGLISH) / PARTS LIST	24
A10991 DUAL PURGE CIRCULATING ASSEMBLY (METRIC) / PARTS LIST	25
78949-00 VALVE AND 77367-00 SEAT REPLACEMENT PARTS	26
77620-00 VALVE PLUG KIT (OPTIONAL)	26
RECOMMENDED SPART PARTS	27
WARRANTY POLICIES:	28
LIMITED WARRANTY	28

SAFETY

SAFETY PRECAUTIONS

Before operating, maintaining or servicing any Ransburg electrostatic coating system, read and understand all of the technical and safety literature for your Ransburg products. This manual contains information that is important for you to know and understand. This information relates to USER SAFETY and PREVENTING EQUIPMENT PROBLEMS. To help you recognize this information, we use the following symbols. Please pay particular attention to these sections.

A WARNING! states information to alert you to a situation that might cause serious injury if instructions are not followed.

A CAUTION! states information that tells how to prevent damage to equipment or how to avoid a situation that might cause minor injury.

A NOTE is information relevant to the procedure in progress.

While this manual lists standard specifications and service procedures, some minor deviations may be found between this literature and your equipment. Differences in local codes and plant requirements, material delivery requirements, etc., make such variations inevitable. Compare this manual with your system installation drawings and appropriate Ransburg equipment manuals to reconcile such differences.

Careful study and continued use of this manual will provide a better understanding of the equipment and process, resulting in more efficient operation, longer trouble-free service and faster, easier troubleshooting. If you do not have the manuals and safety literature for your Ransburg system, contact your local Ransburg representative or Ransburg.



WARNING

- The user **MUST** read and be familiar with the Safety Section in this manual and the Ransburg safety literature therein identified.



- This manual **MUST** be read and thoroughly understood by **ALL** personnel who operate, clean or maintain this equipment! Special care should be taken to ensure that the **WARNINGS** and safety requirements for operating and servicing the equipment are followed. The user should be aware of and adhere to ALL local building and fire codes and ordinances as well as **NFPA-33 SAFETY STANDARD, LATEST EDITION**, prior to installing, operating, and/or servicing this equipment.







WARNING

- The hazards shown on the following pages may occur during the normal use of this equipment. Please read the hazard chart beginning on page 2.

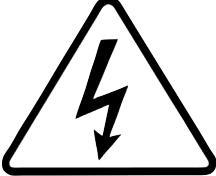
AREA Tells where hazards may occur.	HAZARD Tells what the hazard is.	SAFEGUARDS Tells how to avoid the hazard.
<p>Spray Area</p> 	<p>Fire Hazard</p> <p>Improper or inadequate operation and maintenance procedures will cause a fire hazard.</p> <p>Protection against inadvertent arcing that is capable of causing fire or explosion is lost if any safety interlocks are disabled during operation. Frequent Power Supply or Controller shutdown indicates a problem in the system requiring correction.</p>	<p>Fire extinguishing equipment must be present in the spray area and tested periodically.</p> <p>Spray areas must be kept clean to prevent the accumulation of combustible residues.</p> <p>Smoking must never be allowed in the spray area.</p> <p>The high voltage supplied to the atomizer must be turned off prior to cleaning, flushing or maintenance.</p> <p>When using solvents for cleaning:</p> <ul style="list-style-type: none"> • Those used for equipment flushing should have flash points equal to or higher than those of the coating material. • Those used for general cleaning must have flash points above 100°F (37.8°C). <p>Spray booth ventilation must be kept at the rates required by NFPA-33, OSHA, country, and local codes. In addition, ventilation must be maintained during cleaning operations using flammable or combustible solvents.</p> <p>Electrostatic arcing must be prevented. Safe sparking distance must be maintained between the parts being coated and the applicator. A distance of 1 inch for every 10KV of output voltage is required at all times.</p> <p>Test only in areas free of combustible material. Testing may require high voltage to be on, but only as instructed.</p> <p>Non-factory replacement parts or unauthorized equipment modifications may cause fire or injury.</p> <p>If used, the key switch bypass is intended for use only during setup operations. Production should never be done with safety interlocks disabled.</p> <p>Never use equipment intended for use in waterborne installations to spray solvent based materials.</p> <p>The paint process and equipment should be set up and operated in accordance with NFPA-33, NEC, OSHA, local, country, and European Health and Safety Norms.</p>

<p>AREA Tells where hazards may occur.</p>	<p>HAZARD Tells what the hazard is.</p>	<p>SAFEGUARDS Tells how to avoid the hazard.</p>
<p>Spray Area</p> 	<p>Explosion Hazard</p> <p>Improper or inadequate operation and maintenance procedures will cause a fire hazard.</p> <p>Protection against inadvertent arcing that is capable of causing fire or explosion is lost if any safety interlocks are disabled during operation.</p> <p>Frequent Power Supply or Controller shutdown indicates a problem in the system requiring correction.</p>	<p>Electrostatic arcing must be prevented. Safe sparking distance must be maintained between the parts being coated and the applicator. A distance of 1 inch for every 10KV of output voltage is required at all times.</p> <p>Unless specifically approved for use in hazardous locations, all electrical equipment must be located outside Class I or II, Division 1 or 2 hazardous areas, in accordance with NFPA-33.</p> <p>Test only in areas free of flammable or combustible materials.</p> <p>The current overload sensitivity (if equipped) MUST be set as described in the corresponding section of the equipment manual. Protection against inadvertent arcing that is capable of causing fire or explosion is lost if the current overload sensitivity is not properly set. Frequent power supply shutdown indicates a problem in the system which requires correction.</p> <p>Always turn the control panel power off prior to flushing, cleaning, or working on spray system equipment.</p> <p>Before turning high voltage on, make sure no objects are within the safe sparking distance.</p> <p>Ensure that the control panel is interlocked with the ventilation system and conveyor in accordance with NFPA-33, EN 50176.</p> <p>Have fire extinguishing equipment readily available and tested periodically.</p>
<p>General Use and Maintenance</p> 	<p>Improper operation or maintenance may create a hazard.</p> <p>Personnel must be properly trained in the use of this equipment.</p>	<p>Personnel must be given training in accordance with the requirements of NFPA-33, EN 60079-0.</p> <p>Instructions and safety precautions must be read and understood prior to using this equipment.</p> <p>Comply with appropriate local, state, and national codes governing ventilation, fire protection, operation maintenance, and housekeeping. Reference OSHA, NFPA-33, EN Norms and your insurance company requirements.</p>

<p>AREA Tells where hazards may occur.</p>	<p>HAZARD Tells what the hazard is.</p>	<p>SAFEGUARDS Tells how to avoid the hazard.</p>
<p>Spray Area / High Voltage Equipment</p> 	<p>Electrical Discharge</p> <p>There is a high voltage device that can induce an electrical charge on ungrounded objects which is capable of igniting coating materials.</p> <p>Inadequate grounding will cause a spark hazard. A spark can ignite many coating materials and cause a fire or explosion.</p>	<p>Parts being sprayed and operators in the spray area must be properly grounded.</p> <p>Parts being sprayed must be supported on conveyors or hangers that are properly grounded. The resistance between the part and earth ground must not exceed 1 meg ohm. (Refer to NFPA-33.)</p> <p>Operators must be grounded. Rubber soled insulating shoes should not be worn. Grounding straps on wrists or legs may be used to assure adequate ground contact.</p> <p>Operators must not be wearing or carrying any ungrounded metal objects.</p> <p>When using an electrostatic handgun, operators must assure contact with the handle of the applicator via conductive gloves or gloves with the palm section cut out.</p> <p>NOTE: REFER TO NFPA-33 OR SPECIFIC COUNTRY SAFETY CODES REGARDING PROPER OPERATOR GROUNDING.</p> <p>All electrically conductive objects in the spray area, with the exception of those objects required by the process to be at high voltage, must be grounded. Grounded conductive flooring must be provided in the spray area.</p> <p>Always turn off the power supply prior to flushing, cleaning, or working on spray system equipment.</p> <p>Unless specifically approved for use in hazardous locations, all electrical equipment must be located outside Class I or II, Division 1 or 2 hazardous areas, in accordance with NFPA-33.</p>

<p>AREA Tells where hazards may occur.</p>	<p>HAZARD Tells what the hazard is.</p>	<p>SAFEGUARDS Tells how to avoid the hazard.</p>
<p>Electrical Equipment</p> 	<p>Electrical Discharge</p> <p>High voltage equipment is utilized in the process. Arcing in the vicinity of flammable or combustible materials may occur. Personnel are exposed to high voltage during operation and maintenance.</p> <p>Protection against inadvertent arcing that may cause a fire or explosion is lost if safety circuits are disabled during operation.</p> <p>Frequent power supply shut-down indicates a problem in the system which requires correction.</p> <p>An electrical arc can ignite coating materials and cause a fire or explosion.</p>	<p>Unless specifically approved for use in hazardous locations, the power supply, control cabinet, and all other electrical equipment must be located outside Class I or II, Division 1 and 2 hazardous areas in accordance with NFPA-33 and EN 50176.</p> <p>Turn the power supply OFF before working on the equipment.</p> <p>Test only in areas free of flammable or combustible material.</p> <p>Testing may require high voltage to be on, but only as instructed.</p> <p>Production should never be done with the safety circuits disabled.</p> <p>Before turning the high voltage on, make sure no objects are within the sparking distance.</p>
<p>Toxic Substances</p> 	<p>Certain material may be harmful if inhaled, or if there is contact with the skin.</p>	<p>Follow the requirements of the Material Safety Data Sheet supplied by coating material manufacturer.</p> <p>Adequate exhaust must be provided to keep the air free of accumulations of toxic materials.</p> <p>Use a mask or respirator whenever there is a chance of inhaling sprayed materials. The mask must be compatible with the material being sprayed and its concentration. Equipment must be as prescribed by an industrial hygienist or safety expert, and be NIOSH approved.</p>
<p>Spray Area</p> 	<p>Explosion Hazard – Incompatible Materials</p> <p>Halogenated hydrocarbon solvents for example: methylene chloride and 1,1,1,-Trichloroethane are not chemically compatible with the aluminum that might be used in many system components. The chemical reaction caused by these solvents reacting with aluminum can become violent and lead to an equipment explosion.</p>	<p>Aluminum is widely used in other spray application equipment - such as material pumps, regulators, triggering valves, etc. Halogenated hydrocarbon solvents must never be used with aluminum equipment during spraying, flushing, or cleaning. Read the label or data sheet for the material you intend to spray. If in doubt as to whether or not a coating or cleaning material is compatible, contact your coating supplier. Any other type of solvent may be used with aluminum equipment.</p>

INTRODUCTION

DESCRIPTIONS

The **MCV 2 Collet Series Dual Purge Color Changer** is designed with either English or Metric dual fluid lines to take advantage of the true dual purge capabilities of the applicators; Evolver and RMA-202. The design of these applicators allows the spraying under voltage of one side while the other side is being cleaned with no loss of voltage during the spray. Also, included with this assembly is a solvent/air purge block.

The 78949-00 microvalve was designed to trigger up to 2-million cycles. The fluid and air sections are separated by a weep port to prevent contamination between air and fluid.

SPECIFICATIONS

Electrical / Physical

Operating Pressure:

Fluid 300 psi max. (20.68 bar)

Operating Temperature

Range: 55°F (12.8°C)
130°F (54°C)

Fluid Tube (Metric):

Inlet 10mm ODT
Circulation 8mm ODT
Solvent/Air Purge 10mm ODT
End Plate Outlet 1/4-inch NPSM "AN" Style

Air Tube (Metric):

Actuation 4mm ODT Inlet

Fluid Tube (Fraction):

Inlet 3/8-inch ODT
Circulation 5/16-inch ODT
Solvent/Air Purge 3/8-inch ODT
End Plate Outlet 1/4-inch NPSM "AN" Style

Air Tube (Metric-Fraction):

Actuation 5/32-inch
(4mm) ODT Inlet

Air Actuating

Pressure: 75-120 psi (5.2-8.3 bar)

Maximum Number of Colors: 32

Construction Materials:

Stainless Steel
UHMW

A10986-AA PRE-ENGINEERED DUAL PURGE ASSEMBLIES (ENGLISH)

The following is for “pre-engineered” dual purge assemblies. Please reference “A10986-AA Pre-Engineered Dual Purge Assemblies (English) Parts List” for the changer assembly number.

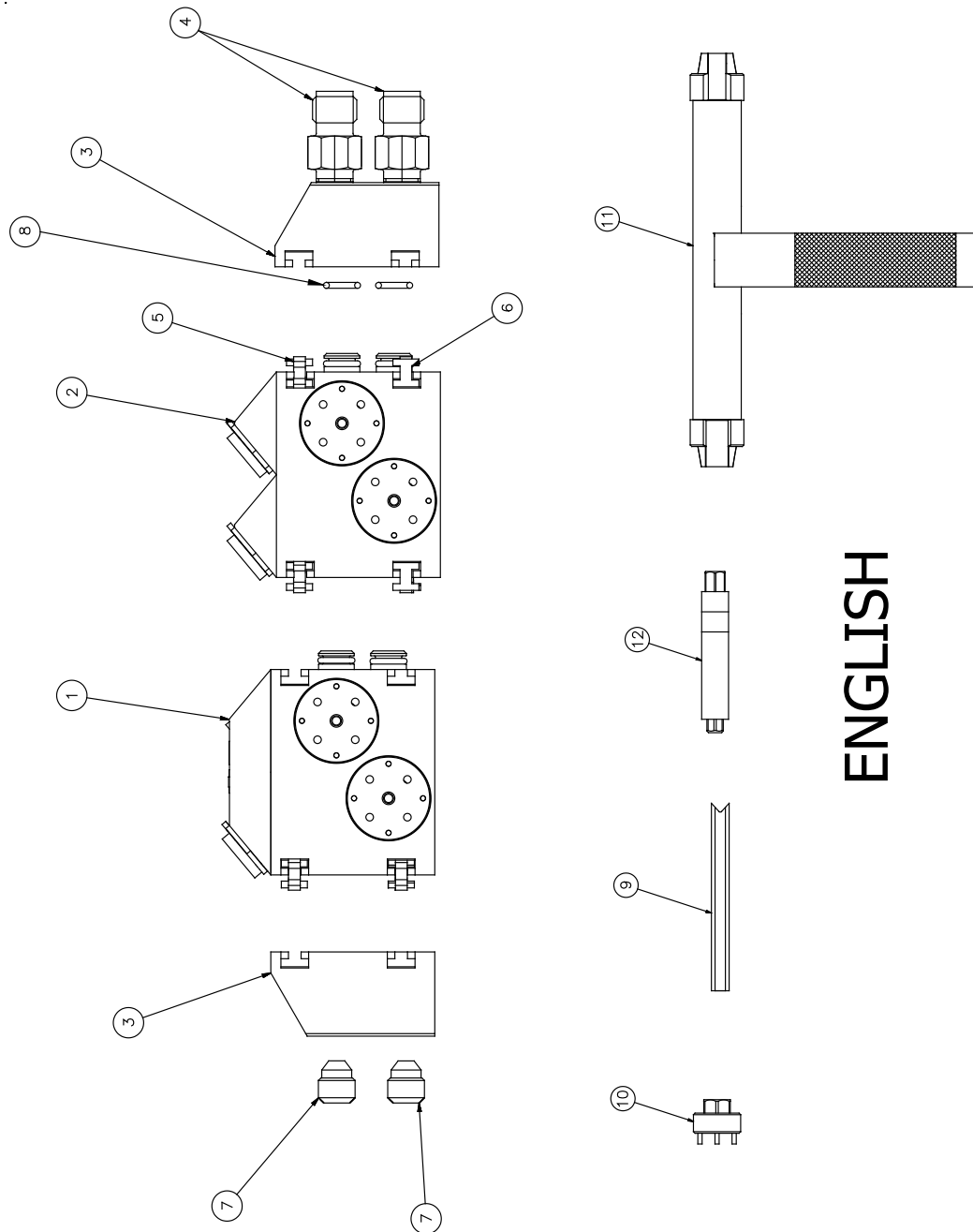

ENGLISH

Figure 1: A10986-AA Pre-Engineered Dual Purge Assemblies (English)

A10986-AA PRE-ENGINEERED DUAL PURGE ASSEMBLIES (ENGLISH) - PARTS LIST (Figure 1)			
Item #	Part #	Description	Qty
1	A10984-00	Assembly, Body Dual Purge Solvent/Air, 3/8"	1
2	A10981-00	Assembly, Body Dual Purge Circulating, 3/8"	See Table AA - "A"
3	A10979-00	Plate, End Dual Purge	2
4	A11568-00	Adapter, 7/16" AN to 1/4" NPSM	2
5	77957-00	Retaining Clip, Color Changer	1
6	A10985-00	Clip, MCV 2 Dual Purge	2
7	A10977-00	Fitting, Outlet	2
8	79001-05	O-Ring	2
9	78078-00	Tool, Retaining Clip Remove	1
10	A10756-00	Tool, Valve Removal	1
11	A10758-00	Tool, Hose Removal	1
12	A10766-00	Tool, Valve Seat Removal	1
13	A11539-00	Plate, End Dual Purge, Fitting End	1

A10986-AA PRE-ENGINEERED DUAL PURGE ASSEMBLIES MODEL IDENTIFICATION (ENGLISH)

When ordering, use A10986-AA as indicated by the Table. "AA" Designates the Number of Color Valves. Example:

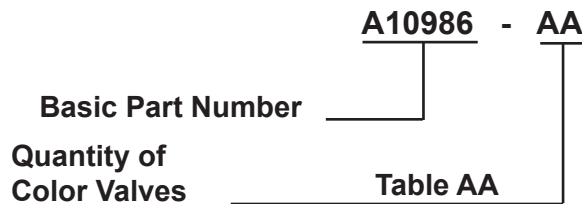
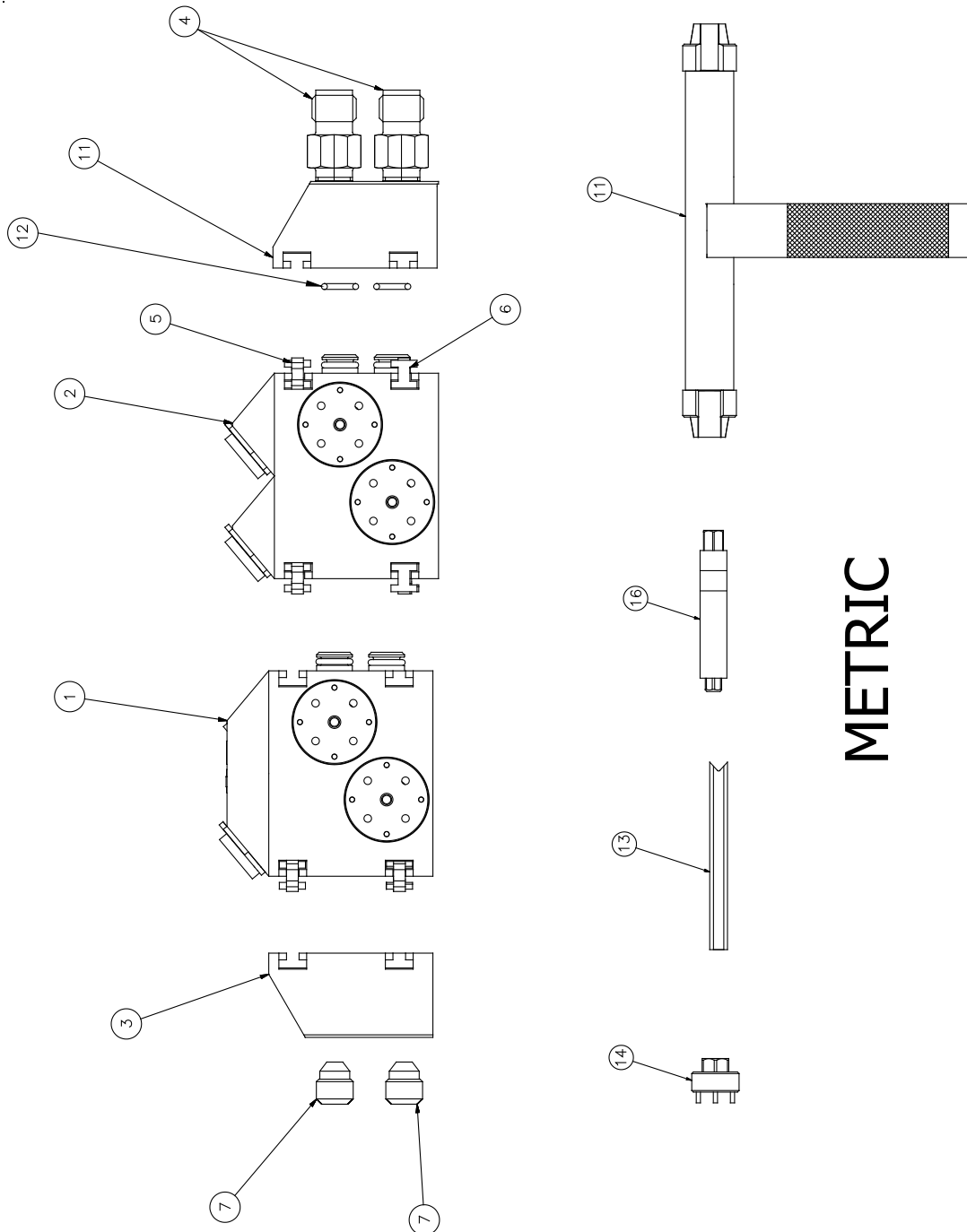

TABLE AA NUMBER OF COLOR VALVES		
Dash No.	Description	"A"
00	0 Color - Color Changer	0
02	2 Color - Color Changer	1
04	4 Color - Color Changer	2
06	6 Color - Color Changer	3
08	8 Color - Color Changer	4
10	10 Color - Color Changer	5
12	12 Color - Color Changer	6
14	14 Color - Color Changer	7
16	16 Color - Color Changer	8
18	18 Color - Color Changer	9
20	20 Color - Color Changer	10
22	22 Color - Color Changer	11
24	24 Color - Color Changer	12
26	26 Color - Color Changer	13
28	28 Color - Color Changer	14
30	30 Color - Color Changer	15
32	32 Color - Color Changer	16

A10993-XX PRE-ENGINEERED DUAL PURGE ASSEMBLIES (METRIC)

The following is for “pre-engineered” dual purge assemblies. Please reference “A10993-XX Pre-Engineered Dual Purge Assemblies (Metric) Parts List” for the changer assembly number.



METRIC

Figure 2: A10993-XX Pre-Engineered Dual Purge Assemblies (Metric)

A10993-XX PRE-ENGINEERED DUAL PURGE ASSEMBLIES (METRIC) - PARTS LIST (Figure 2)			
Item #	Part #	Description	Qty
1	A10992-00	Assembly, Body Dual Purge Solvent/Air 10mm	1
2	A10991-00	Assembly, Body Dual Purge Circulating 10mm	See Table AA - "A"
3	A10979-00	Plate, End Dual Purge	1
4	A11568-00	Adapter, 7/16" AN to 1/4" NPSM	2
5	77957-00	Retaining Clip, Color Changer	1
6	A10985-00	Clip, MCV 2 Dual Purge	2
7	A10977-00	Fitting, Outlet	2
8	A11539-00	Plate, End Dual Purge, Fitting End, Metric	1
9	79001-05	O-Ring	2
10	78078-00	Tool, Retaining Clip Remove	1
11	A10756-00	Tool, Valve Removal	1
12	A10758-00	Tool, Hose Removal	1
13	A10766-00	Tool, Valve Seat Removal	1

A10993-XX PRE-ENGINEERED DUAL PURGE ASSEMBLIES MODEL IDENTIFICATION (Metric)

When ordering, use A10993-AA as indicated by the Table. "AA" Designates the Number of Color Valves. Example:

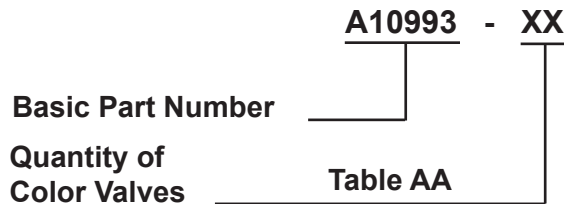

TABLE AA NUMBER OF COLOR VALVES		
Dash No.	Description	"A"
00	0 Color - Color Changer	0
02	2 Color - Color Changer	1
04	4 Color - Color Changer	2
06	6 Color - Color Changer	3
08	8 Color - Color Changer	4
10	10 Color - Color Changer	5
12	12 Color - Color Changer	6
14	14 Color - Color Changer	7
16	16 Color - Color Changer	8
18	18 Color - Color Changer	9
20	20 Color - Color Changer	10
22	22 Color - Color Changer	11
24	24 Color - Color Changer	12
26	26 Color - Color Changer	13
28	28 Color - Color Changer	14
30	30 Color - Color Changer	15
32	32 Color - Color Changer	16

INSTALLATION

MCV INSTALLATION PROCEDURES

Determine Location for Color Changer

The Color Changer should be located as close as possible to the spray device in order to save paint and solvent with a color changer. If possible, use an enclosure to protect the color changer from airborne paints and solvents.

Calculate Footprint of Color Changer (See Figure 3)

To calculate the footprint of the color changer add:

- The dimension of the end plate **A**
- The dimension of the purge assembly **B**
- The dimension(s) of the module(s) used to create the desired number of color valves **C**
- The dimension of the output assembly **D**

Example: To calculate the footprint of a 2-Color MCV Assembly:

1" (End Plate) + 2-7/16" (purge assembly) + 2-7/16" (2-color valve assembly) + 1" (output assembly) = 17-3/4".

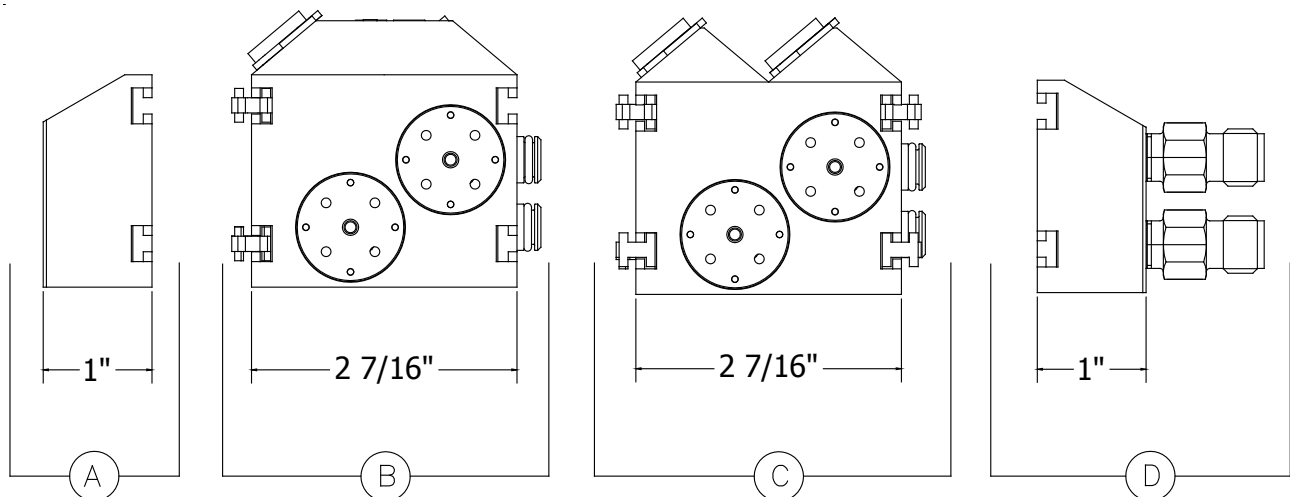

Figure 3: Calculate Footprint

Mounting the Color Changer

The mounting configurations are as follows (reference Figure 4):

- 5/16" clearance holes for flush mounting to the booth wall

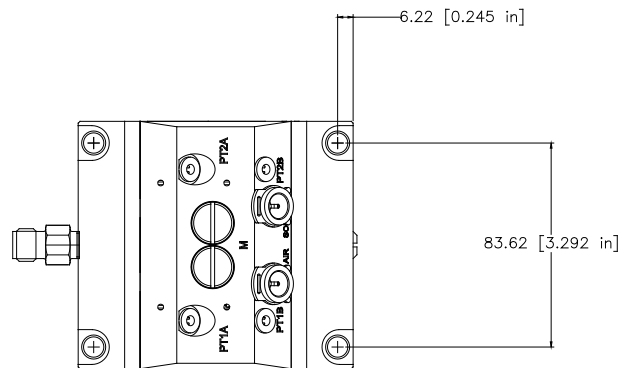

Figure 4: Mounting the Color Changer

Grounding of the Color Changer

For safety, the color changer MUST be grounded. Using a 12-gauge wire, ground the output plate metal mounting screw of the color changer to a true earth ground. Using an ohm meter, check for ground, testing the earth ground to the purge assembly top plate. The resistance should be 10 ohms or less (see Figure 5).

NOTE

- Use metal screws for mounting for grounding purposes.



WARNING

- The color changer MUST be properly grounded. Proper grounding (as described below) will prevent static charge buildup and possible discharge from the color changer.

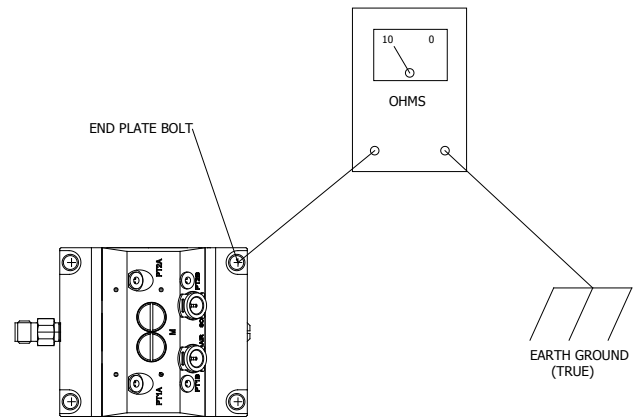

Figure 5: Grounding the Color Changer

OPERATION

OPERATING INSTRUCTIONS

Each slice of the block contains 2 colors, one for each side of the slice. There are two valves on each side which are daisy chained internally. This allows one inbound color line and one outbound color line run from a paint supply to the dual purge stack rather than two lines and two returns for each color. This design uses half the tubing normally needed for the dual purge applications. However, there are two (2) 4mm ODT trigger lines to open the valves to feed line A or line B.

The stack should be mounted as close to the applicator as possible to minimize the waste material left in the tube between the stack and the applicator. An air push may be used to minimize the material waste. However, this requires the applicator to have a regulator on-board to control the fluid pressure and flow to the applicator while air is pushing. Both the Evolver and the RMA-202 have optional on-board fluid regulators available.

The normal function would be to have only one trigger open at a time per side A or B. If more than one trigger is opened per side, material contamination will occur. The exception is the solvent air chop that is required for cleaning the internal porting of the stack.

An example is while Color 1 Trigger A is actuated which would be supplying an applicator, side B is being cleaned from the purge stack to the dump of the applicator. Once cleaning is complete, any color may be loaded into line B.

Figure 6 shows a typical Color Changer Schematics to prevent back flow of material.

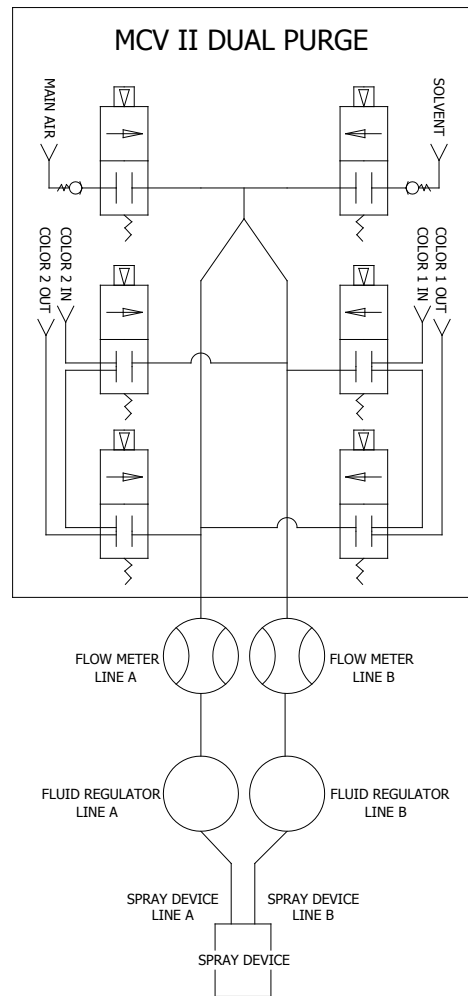

Figure 6: Color Changer Schematics

DIMENSIONS - METRIC (FRACTION) AND PROPOSED HOOK-UP FOR 2 COLORS

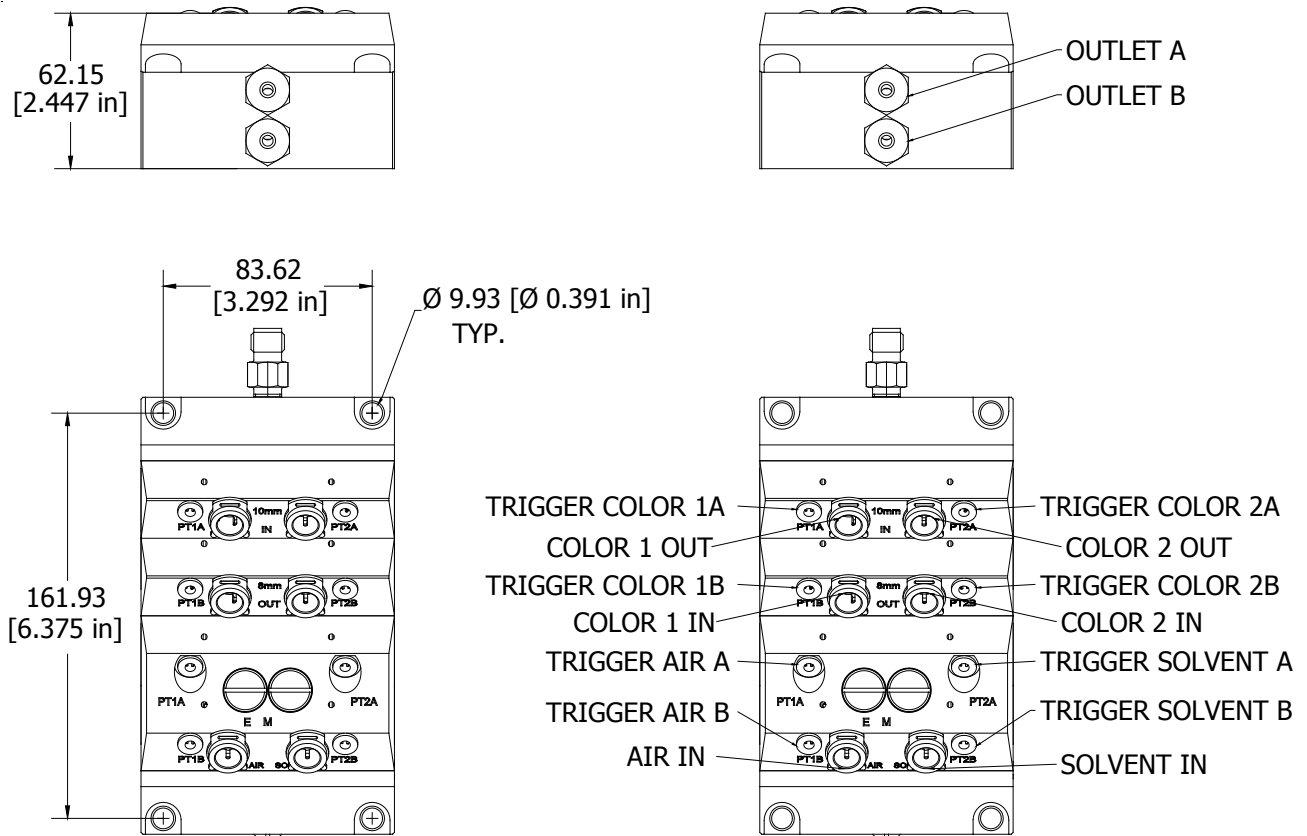

Figure 7: Dimensions-Metric (Fraction) and Proposed Hook-Up

MAINTENANCE

⚠ WARNING

- ▶ Prior to servicing the unit, insure that all fluid pressure is relieved to atmosphere. A solvent purge should be performed if possible.

GENERAL MAINTENANCE

NOTE

- ▶ When replacing or repairing any components in this system, before reassembling, apply a light coat of food grade petroleum jelly to all o-rings.

NOTE

- ▶ This procedure allows valve and/or seat removal without removing the valve slice from the assembly.

Value and Seat Removal

To remove the valve for any reason, insert the (4) prongs from the tool into the holes on the top the Microvalve. Using a 1/2" socket, adjustable wrench or a combination box open end wrench, turn counter-clockwise to remove the valve.

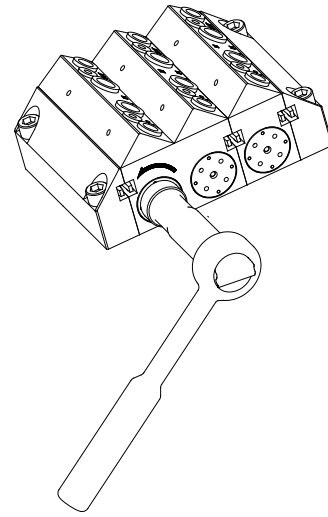

Figure 8: Valve Removal

To remove the seat, insert the seat removal tool into the seat and turn counter-clockwise using a 3/8" socket, adjustable wrench or combination box open end wrench.

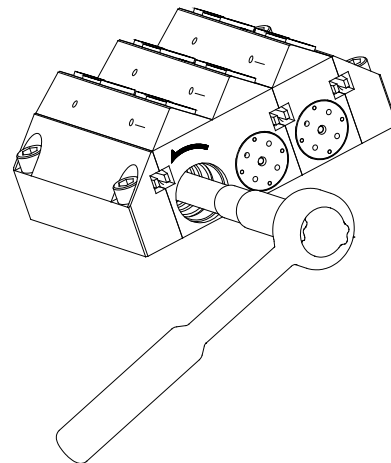

Figure 9: Seat Removal

To reinstall, tighten the valve seat first using the tool by hand. Then using a torque wrench with a 3/8" socket, tighten the seat in place, clockwise in direction to 15-20 lbs•in torque.

CAUTION

- ▶ Not using a torque wrench for seat installation may cause permanent damage to the seal pocket of the valve block.

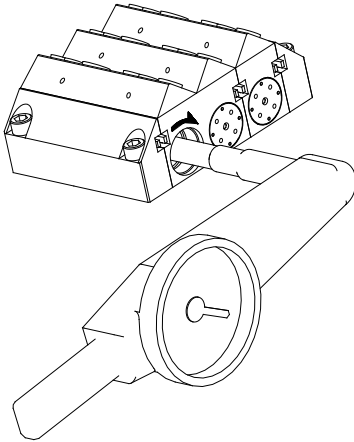

Figure 10: Reinstall Valve and Seat

To install the Microvalve, tighten the valve into the pocket using the provided tool and a 1/2" wrench or socket clockwise until the valve has just about seated. Then using a torque wrench tighten to 15-20 lbs•in.

CAUTION

- ▶ Be careful not to cross thread the parts when reassembling. Could cause permanent damage to block.

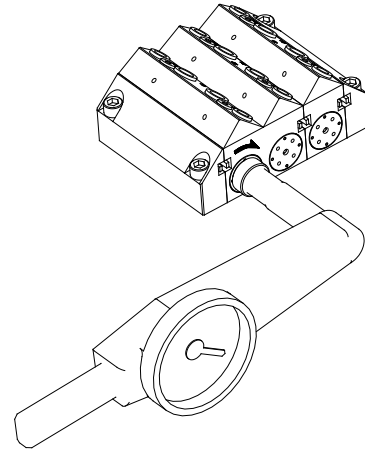

Figure 11: Microvalve Installation

Tube Insertion

Prior to inserting the tube, remove the red clip under the collet. Insert the tube into the stack collet by grasping the tube about 2-4-inches from the chamfered end. Press the tube all the way down in the collet until it cannot be pressed any further, the tube must pass by both o-rings. Each tube must be inserted into its mating collet to the proper depth as shown in the chart below. With the tube inserted, pull the collet up enough to slide the clip under the collet.

Tube OD	Tube Depth
3/8" or 10mm	3/4" or 19.0mm
5/16" or 8mm	11/16" or 17.5mm
5/32" or 4mm	5/8" or 16.0mm

Tube Removal

The 5/32-inch (4mm) trigger line tubes may be removed by hand by pushing on the collet while pulling out the tube. A tool is required to remove both the 5/16-inch (8mm) and 3/8-inch (10mm) tube. To remove the 10mm tube, use the black inserted end of the tool. For the 8mm tube, use the white inserted end. First remove the red clips then press the tool against the collet in the block. With the collet pushed in, pull out the tube that is being removed (see Figure 12).

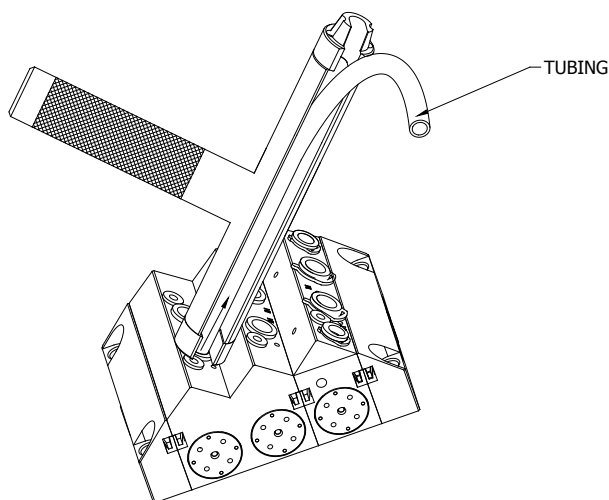

Figure 12: Tube Removal

! WARNING

- Prior to servicing the unit, insure that all fluid pressure is relieved to atmosphere. A solvent purge should be performed if possible.

REMOVING AND REINSTALLING A VALVE BLOCK FROM A STACK

1. Insure all pressure is bled off the system. If possible, flush the block with appropriate solvent.
2. Using the clip removal tool (78078-00), push on the installed locking clip with the "V" cut as shown in Figure 13.
3. Push the upper locking clip out of the locking slots using the removal tool.

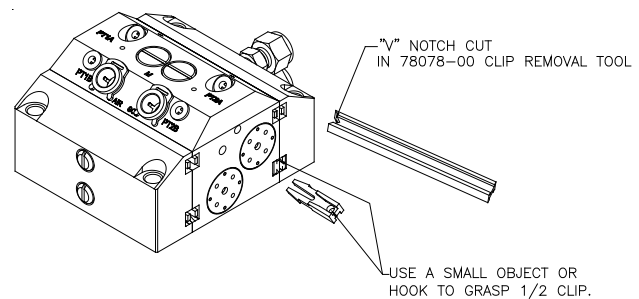

Figure 13: Removing and Reinstalling Valve Block from a Stack

4. Pull out the 1/2-inch clip as shown in Figure 13.
5. Loosen and remove any mounting bolts holding the stack in place.
6. Carefully pull the stack assembly ends apart and remove the valve block.

! WARNING

- Be careful of residual fluid pressure or solvent pressure in the line. Cover the area where the valve slice is being removed to prevent any solvent or paint from spraying out.

7. Replace the valve slice, push the assembly together, and insert the locking clips.

TEST AND CHECKOUT PROCEDURE FOR COLOR CHANGER

Step 1:

1. Connect air line to a regulated air supply.
2. Attach the air line to a ball valve assembled to the outlet of the color changer.
3. Adjust the air supply pressure to 100 psi (6.9 bar).
4. Open the ball valve at the outlet of the color changer.
5. Apply a soap solution on the color changer manifold.
6. Check the manifold assembly's mating surfaces between color blocks for soap bubbles.

NOTE

- If bubbles are observed, dismantle color changer manifold and repair as required.

7. If no bubbles are present, rinse manifold with water and blow dry with air.

Step 2:

1. Attach two (2) regulated air supply hoses, one with a 3-way valve (normally closed) for operating the color valve cylinder on the color changer. (Set the pressure to the 3-way valve at 75 psi (5.8 bar) or more.)

The second hose will be used for supplying 100 psi (6.9 bar) of air to the color inlet port of each color changer valve.

2. Connect the air supply hose with 100 psi (6.9 bar) to color inlet valve. Connect a 2-way ball valve to the matching return port on the color changer manifold.

3. Turn the ball valve installed on the paint circulation fitting to verify recirculation ability.

NOTE

- Ensure valve is closed when completed.

4. Connect the air supply with a 3-way valve (normally closed) to the color valve cylinder.
5. Activate the 3-way valve to operate the color valve.

NOTE

- The piston rod on the top of the color valve assembly should **EXTEND** and air should blow out of the color changer outlet. Check for a crisp and sharp actuation of the color valve air cylinder.

6. Deactivate the 3-way valve and close the color valves.

NOTE

- The piston rod on the top of the color valve assembly should be **RETRACTED**, and the air should have stopped blowing out of the outlet of the color changer.

7. Connect a 1/4-inch (6.4 cm) ID hose 3-feet (91.4cm) long to the outlet of the color changer.

8. Acquire a container of water and fill it with about 4-inches (10.6 cm) of WATER.

Position the hose in the container filled with water.

9. There should be no more than 6 bubbles per minute coming from the outlet of the hose that is submerged.
10. If there are more than 6 bubbles per minute, remove the color valve assembly, replace the valve seat (77367-00) and reinstall color valve assembly. If the new seat does not correct the problem, either the manifold block or color valve assembly is defective.
11. Proceed to the next color valve and repeat Steps 2 thru 11.
12. When all the color valves are checked out, then check the purge valve assembly repeating Steps 2 thru 11.
13. Once all valves are operational, deactivate the 3-way valve, and then disconnect the air lines used for testing from the color changer.

! WARNING

► **ALWAYS** test color changer for conductivity after assembly or repair. Proper conductivity is required to assure entire color changer can be properly grounded when installed.

! WARNING

► **NEVER** wrap the equipment in plastic to keep it clean. A surface charge may build-up on the plastic surface and discharge to the nearest grounded object. Efficiency of the equipment will also be reduced and damage or failure of the equipment's components may occur. **WRAPPING THE EQUIPMENT** in plastic will void warranty.

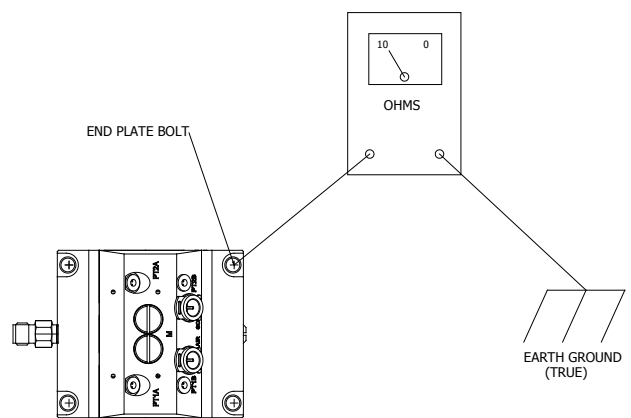

Figure 14: Ground Test

14. With an ohm meter, check for conductivity between the top plate of the purge valve and the output plate on the color changer. There should be 10 ohms or less between the two points (see Figure 14).

PARTS IDENTIFICATION

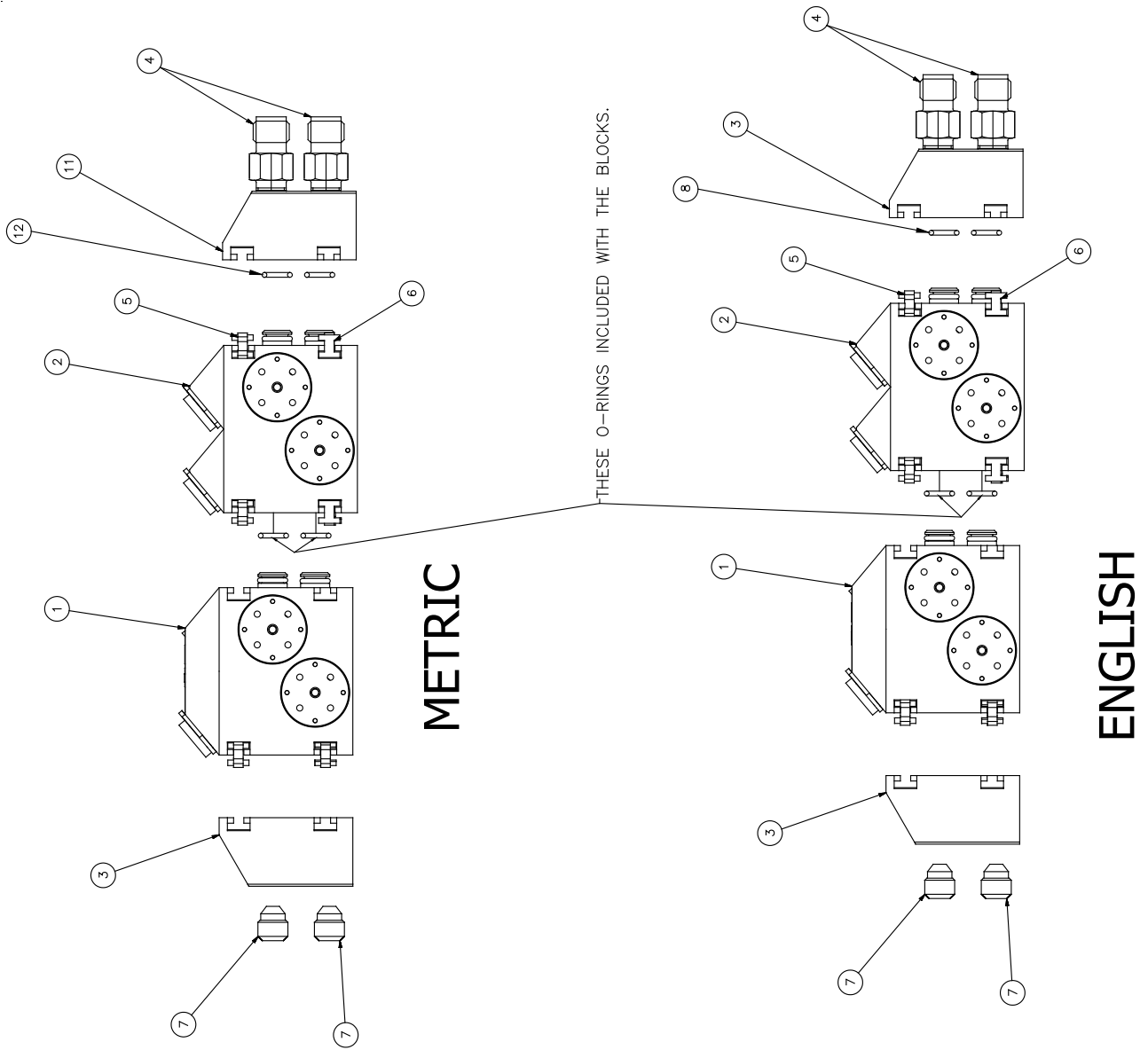

Figure 15: A10986-AA (English) and A10993-XX (Metric) Dual Purge Assemblies

A10986-AA DUAL PURGE ASSEMBLY (ENGLISH) - PARTS LIST (Figure 15)			
Item #	Part #	Description	Qty
1	A10984-00	Assembly, Body Dual Purge Solvent/Air, 3/8"	1
2	A10981-00	Assembly, Body Dual Purge Circulating, 3/8"	See Table AA - "A"
3	A10979-00	Plate, End Dual Purge	2
4	A11568-00	Adapter, 7/16" AN to 1/4" NPSM	2
5	77957-00	Retaining Clip, Color Changer	1
6	A10985-00	Clip, MCV 2 Dual Purge	2
7	A10977-00	Fitting, Outlet	2
8	A11539-00	Plate, End Dual Purge, Fitting End	1
9	79001-05	O-Ring	2

A10993-XX DUAL PURGE ASSEMBLY (METRIC) - PARTS LIST (Figure 15)			
Item #	Part #	Description	Qty
1	A10992-00	Assembly, Body Dual Purge Solvent/Air, 10mm	1
2	A10991-00	Assembly, Body Dual Purge Circulating, 10mm	See Table AA - "A"
3	A10979-00	Plate, End Dual Purge	1
4	A11568-00	Adapter, 7/16" AN to 1/4" NPSM	2
5	77957-00	Retaining Clip, Color Changer	1
6	A10985-00	Clip, MCV 2 Dual Purge	2
7	A10977-00	Fitting, Outlet	2
8	A11539-00	Plate, End Dual Purge, Fitting End, Metric	1
9	79001-05	O-Ring	2

TABLE AA NUMBER OF COLOR VALVES		
Dash No.	Description	"A"
00	0 Color - Color Changer	0
02	2 Color - Color Changer	1
04	4 Color - Color Changer	2
06	6 Color - Color Changer	3
08	8 Color - Color Changer	4
10	10 Color - Color Changer	5
12	12 Color - Color Changer	6
14	14 Color - Color Changer	7
16	16 Color - Color Changer	8
18	18 Color - Color Changer	9
20	20 Color - Color Changer	10
22	22 Color - Color Changer	11
24	24 Color - Color Changer	12
26	26 Color - Color Changer	13
28	28 Color - Color Changer	14
30	30 Color - Color Changer	15
32	32 Color - Color Changer	16

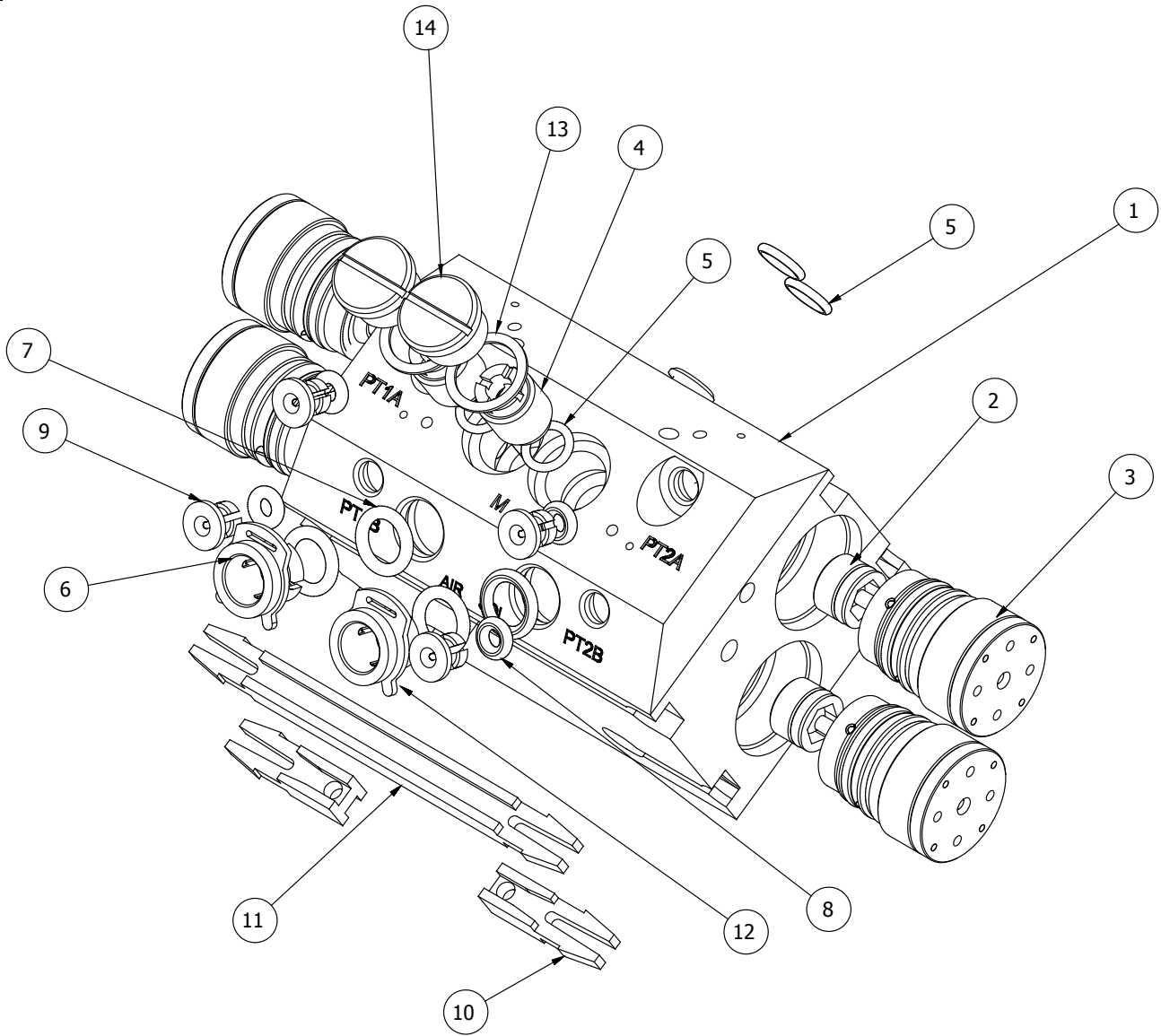

Figure 16: A10984 (English) and A10992 (Metric) Dual Purge Solvent / Air Assembly

**A10984 DUAL PURGE SOLVENT / AIR ASSEMBLY
(ENGLISH) - PARTS LIST (Figure 16)**

Item #	Part #	Description	Qty
1	A10983-00	Assembly, Body Dual Purge Solvent/Air, 3/8"	1
2	77367-00	Assembly, Valve Seat	4
3	78949-00	Assembly, Valve	4
4	78944-00	Assembly, Check Valve	2
5	79001-06	O-Ring, Solvent Proof	4
6	77762-05	Collet, Tube Fitting, 3/8"	2
7	79001-24	O-Ring, Solvent Proof	4
8	79001-30	O-Ring, Solvent Proof	4
9	77516-04	Collet, 5/32"	4
10	A10985-00	Clip, MCV 2 Dual Purge	2
11	77957-00	Retaining Clip, Color Changer	1
12	A10824-00	Red Locking Clip, 3/8" OD Tube	2
13	78947-00	Seal	2
14	78945-00	Plug, Check Valve	2

**A10992 DUAL PURGE SOLVENT / AIR ASSEMBLY
(METRIC) - PARTS LIST (Figure 16)**

Item #	Part #	Description	Qty
1	A10990-00	Assembly, Body Dual Purge Solvent/Air, 10mm	1
2	77367-00	Assembly, Valve Seat	4
3	78949-00	Assembly, Valve	4
4	78944-00	Assembly, Check Valve	2
5	79001-06	O-Ring, Solvent Proof	4
6	77762-02	Collet, Tube Fitting, 10mm	2
7	79001-31	O-Ring, Solvent Proof	4
8	79001-30	O-Ring, Solvent Proof	4
9	77516-04	Collet, 4mm	4
10	A10985-00	Clip, MCV 2 Dual Purge	2
11	77957-00	Retaining Clip, Color Changer	1
12	A10824-00	Red Locking Clip, 10mm OD Tube	2
13	78947-00	Seal	2
14	78945-00	Plug, Check Valve	2

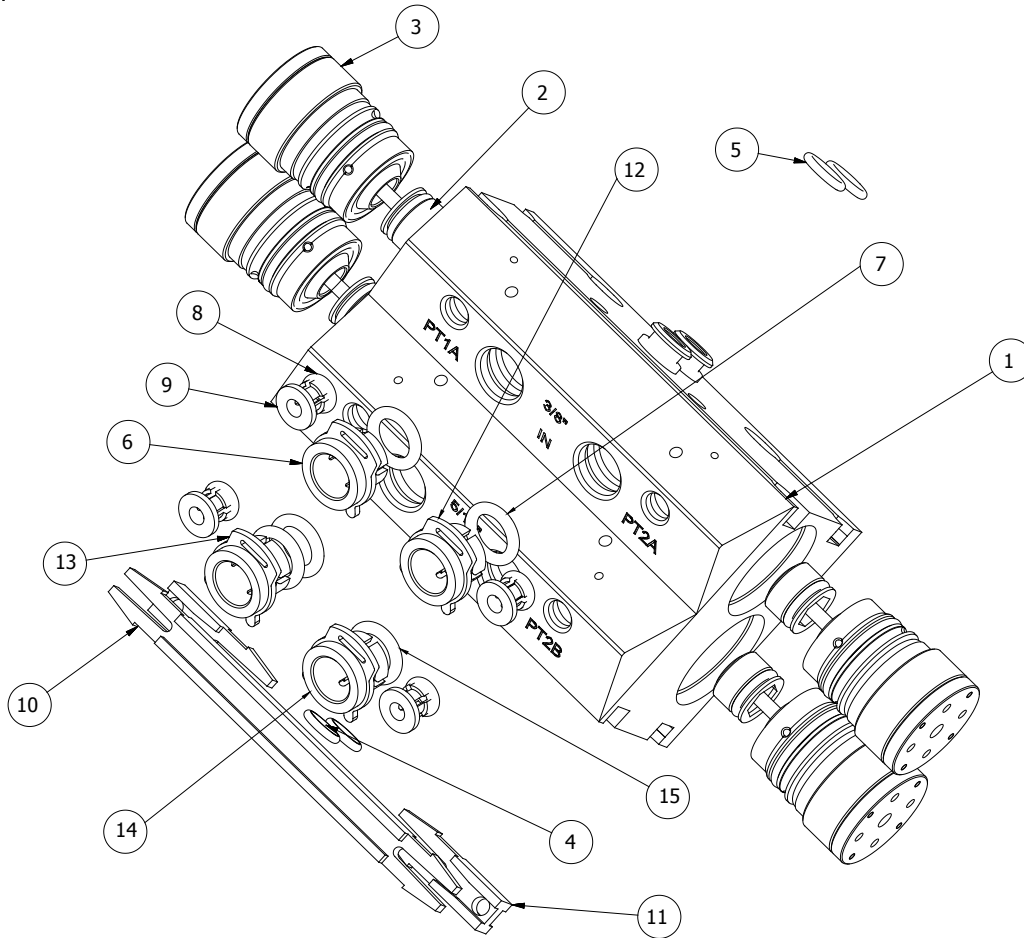

Figure 17: A10981 Dual Purge Circulating Assembly (English)

A10981 DUAL PURGE CIRCULATING ASSEMBLY (ENGLISH) - PARTS LIST (Figure 17)			
Item #	Part #	Description	Qty
1	A10989-00	Assembly, Body Dual Purge Circulating/Air, 3/8"	1
2	77367-00	Assembly, Valve Seat	4
3	78949-00	Assembly, Valve	4
4	79001-05	O-Ring, Solvent Proof	2
5	79001-06	O-Ring, Solvent Proof	2
6	77516-02	Collet, Tube Fitting, 3/8"	2
7	79001-24	O-Ring, Solvent Proof	4
8	79001-30	O-Ring, Solvent Proof	4
9	77516-04	Collet, 5/32"	4
10	77957-00	Retaining Clip, Color Changer	1
11	A10985-00	Clip, MCV 2 Dual Purge	2
12	A10824-00	Red Locking Clip, 3/8" OD Tube	4
13	A10825-00	Red Locking Clip, 1/4" OD Tube	2
14	77762-04	Collet, Tube Fitting, 5/16"	2
15	79001-34	O-Ring, Solvent Proof	4

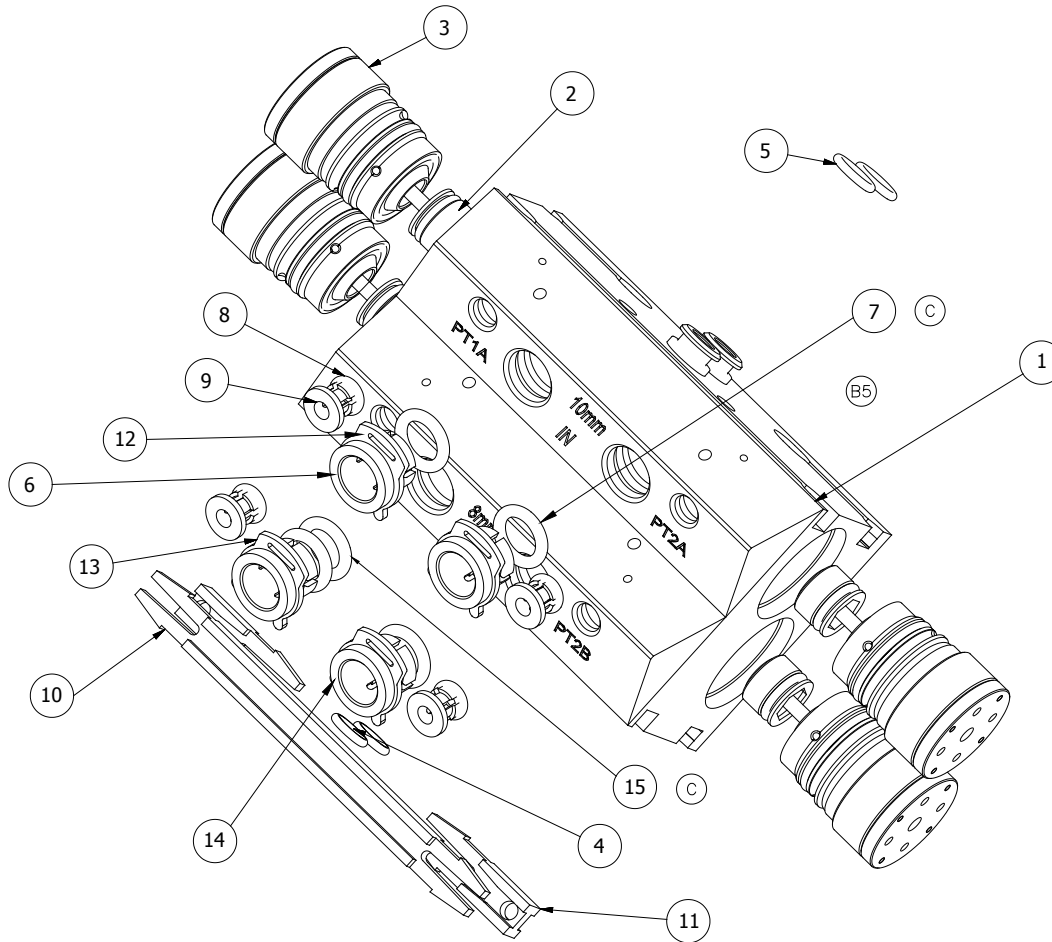

Figure 18: A10991 Dual Purge Circulating Assembly (Metric)

A10991 DUAL PURGE CIRCULATING ASSEMBLY (METRIC) - PARTS LIST (Figure 18)			
Item #	Part #	Description	Qty
1	A10989-00	Assembly, Body Dual Purge Circulating/Air, 10mm	1
2	77367-00	Assembly, Valve Seat	4
3	78949-00	Assembly, Valve	4
4	79001-05	O-Ring, Solvent Proof	2
5	79001-06	O-Ring, Solvent Proof	2
6	77762-02	Collet, Tube Fitting, 10mm	2
7	79001-31	O-Ring, Solvent Proof	4
8	79001-30	O-Ring, Solvent Proof	4
9	77516-04	Collet, 4mm	4
10	77957-00	Retaining Clip, Color Changer	1
11	A10985-00	Clip, MCV 2 Dual Purge	2
12	A10824-00	Red Locking Clip, 10mm OD Tube	4
13	A10825-00	Red Locking Clip, 8mm OD Tube	2
14	77762-04	Collet, Tube Fitting, 8mm	2
15	79001-34	O-Ring, Solvent Proof	4

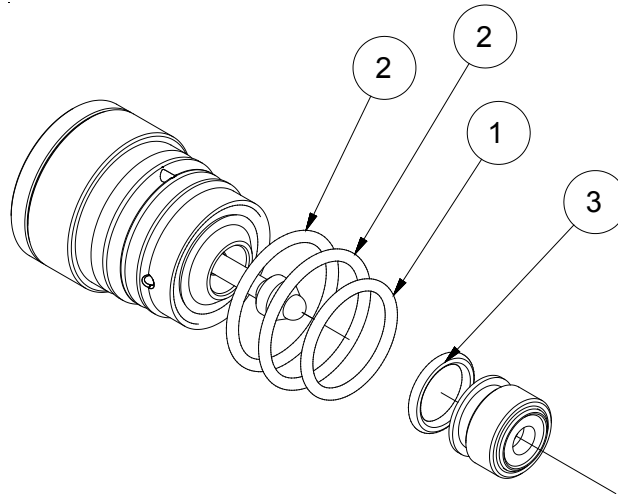

Figure 19a: 78949-00 Valve & 77367-00 Seat Replacement Parts

78949-00 VALVE & 77367-00 SEAT REPLACEMENT PARTS (Figure 19a)			
Item #	Part #	Description	Qty
1	79001-01	O-Ring, Solvent Proof	1
2	79001-02	O-Ring, Solvent Proof	2
3	79001-14	O-Ring, Solvent Proof	1

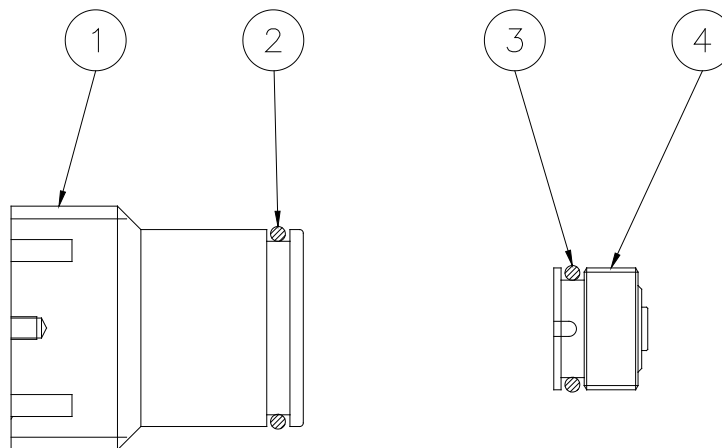

Figure 19b: 77620-00 Valve Plug Kit (Optional)

77620 VALVE PLUG KIT (Optional) (Use in place of Valve & Seat) (Figure 19b)			
Item #	Part #	Description	Qty
1	79244-00	Plug	1
2	79001-19	O-Ring, Solvent Proof	1
3	79001-14	O-Ring, Solvent Proof	1
4	77618-00	Plug, Seat	1

RECOMMENDED SPARE PARTS	
Part #	Description
77957-00	Retaining Clip
A10824-00	Locking Clip
A10825-00	Locking Clip
79001-05	O-Ring, Solvent Proof
79001-06	O-Ring, Solvent Proof

WARRANTY POLICIES

LIMITED WARRANTY

Ransburg will replace or repair without charge any part and/or equipment that fails within the specified time (see below) because of faulty workmanship or material, provided that the equipment has been used and maintained in accordance with Ransburg's written safety and operating instructions, and has been used under normal operating conditions. Normal wear items are excluded.

THE USE OF OTHER THAN RANSBURG APPROVED PARTS VOIDS ALL WARRANTIES.

SPARE PARTS: One hundred and eighty (180) days from date of purchase, except for rebuilt parts (any part number ending in "R") for which the warranty period is ninety (90) days.

EQUIPMENT: When purchased as a complete unit, (examples: guns, power supplies, control units, etc.), is one (1) year from date of purchase. **WRAPPING THE APPLICATOR, ASSOCIATED VALVES AND TUBING, AND SUPPORTING HARDWARE IN PLASTIC, SHRINK-WRAP, OR ANY OTHER NON-APPROVED COVERING, WILL VOID THIS WARRANTY.**

RANSBURG'S ONLY OBLIGATION UNDER THIS WARRANTY IS TO REPLACE PARTS THAT HAVE FAILED BECAUSE OF FAULTY WORKMANSHIP OR MATERIALS. THERE ARE NO IMPLIED WARRANTIES NOR WARRANTIES OF EITHER MERCHANTABILITY OR FITNESS FOR A PARTICULAR PURPOSE. RANSBURG ASSUMES NO LIABILITY FOR INJURY, DAMAGE TO PROPERTY OR FOR CONSEQUENTIAL DAMAGES FOR LOSS OF GOODWILL OR PRODUCTION OR INCOME, WHICH RESULT FROM USE OR MISUSE OF THE EQUIPMENT BY PURCHASER OR OTHERS.

EXCLUSIONS:

If, in Ransburg's opinion the warranty item in question, or other items damaged by this part was improperly installed, operated or maintained, Ransburg will assume no responsibility for repair or replacement of the item or items. The purchaser, therefore will assume all responsibility for any cost of repair or replacement and service related costs if applicable.

MANUAL CHANGE SUMMARY

This manual was published to replace Service Manual **CS-05-01.8, MCV 2 Collet Series Dual Purge Color Changer** to make the following changes:

1. Change logo.

Service Manual Price: \$30.00 (U.S.)

Manufacturing

1910 North Wayne Street
Angola, Indiana 46703-9100
Telephone: 260/665-8800
Fax: 260/665-8516

Technical/Service Assistance

Telephone: 800/ 233-3366
Fax: 419/ 470-2071
www.ransburg.com

Technical Support Representative will direct you to the appropriate telephone number for ordering Spare Parts.