

Gun nozzles for every application

Different extensions, flat spray, round spray and angle nozzles are designed to offer the best results even with difficult applications.

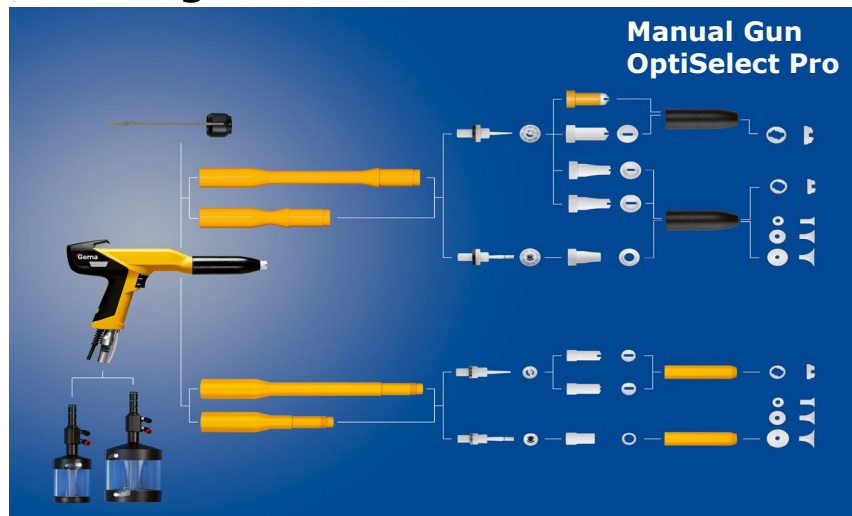

Compliant with **ATEX directive 2014/34/EU**

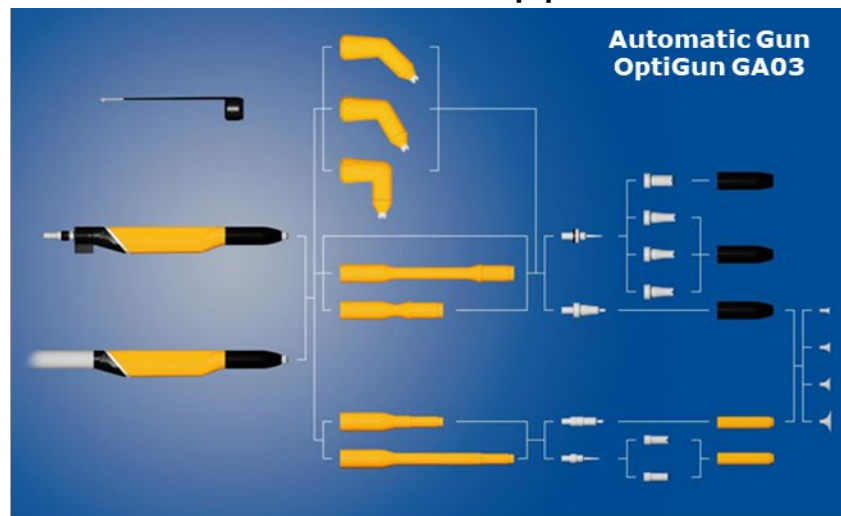

Compliant with **ATEX directive 2014/34/EU**

Highest powder
transfer efficiency

Perfect
powder distribution

Consistent
application quality

Gun nozzle design

- Powder coating requires a perfect combination of nozzle design and high voltage supply to achieve an homogeneous powder cloud.
- The high voltage field plays a very important role ensuring a perfect powder atomization and charging.
- Different object geometries to be coated require different nozzle geometries to ensure that the powder cloud is ideal and at the right speed.

Effect high voltage on powder cloud

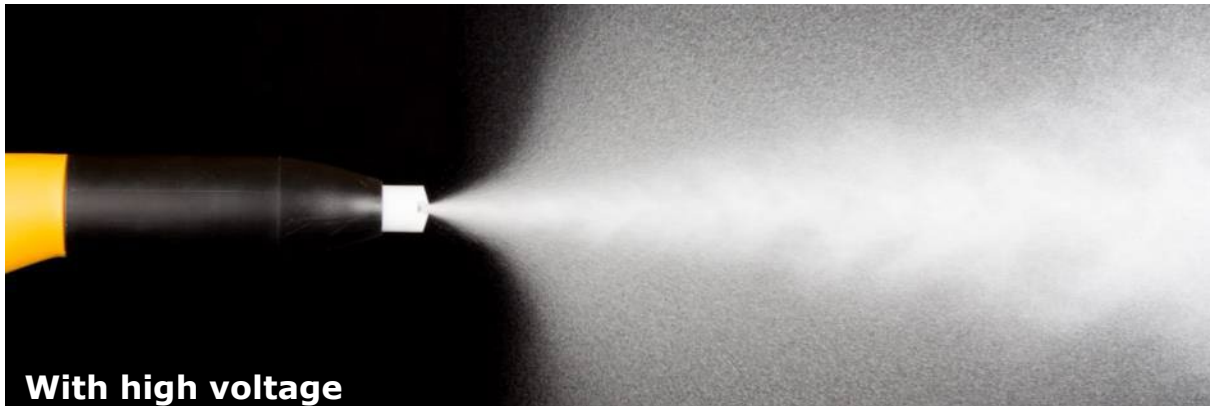
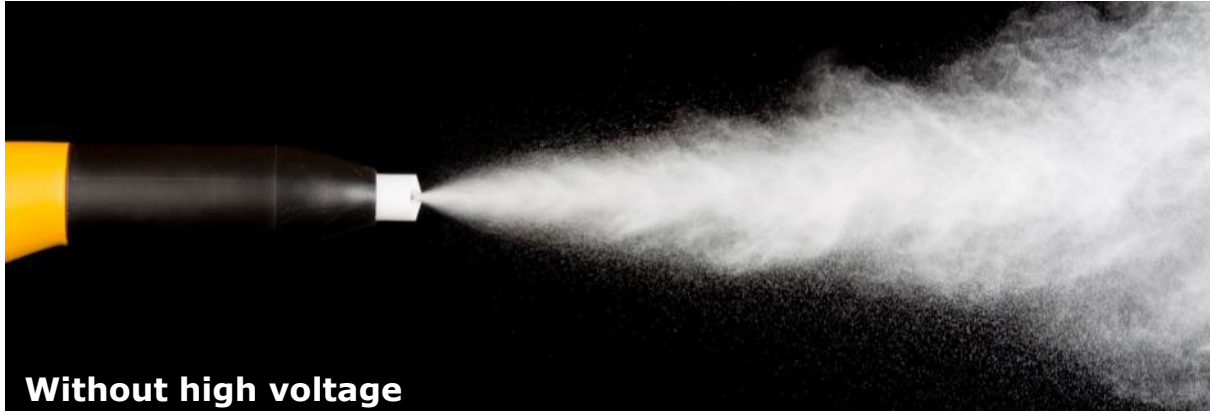

Powder distribution NF27



NF27 Homogeneous powder distribution

Gun nozzles and extensions

- The nozzles and extensions are interchangeable **for manual and automatic guns**, thanks to the compatible and smart gun shaft design.
- All nozzles and extensions are compliant to the **ATEX** directives.
- The use of high quality **non-stick materials** prevents powder accumulations and allows a **high quality color change**.



OptiSelect Pro
Type GM04



OptiGun GA03

Extensions for round and flat jet nozzles

- Manual and automatic guns can be provided with robust and solid nozzle **extensions of 150 and 300 mm length**. These nozzles are interchangeable with the standard nozzles and offer a perfect flexibility of use.
- Smaller and **light-weight extensions** are also available.
 - In manual applications they offer easy and stress-free operation over a long working time.
 - In automatic application, they are ideal for inside coating of narrow areas like in boilers.

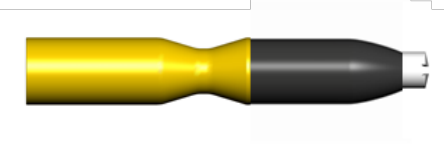

Angle nozzles for special applications

- A wide range of **45°, 60° and 90° angle nozzles** are available for challenging applications.
- The typical area of use are **complex geometries** like profiles, chassis, beam frames and cabinet coating.
- The angle nozzles are also ideal for variety of applications where **fixed guns** are needed.

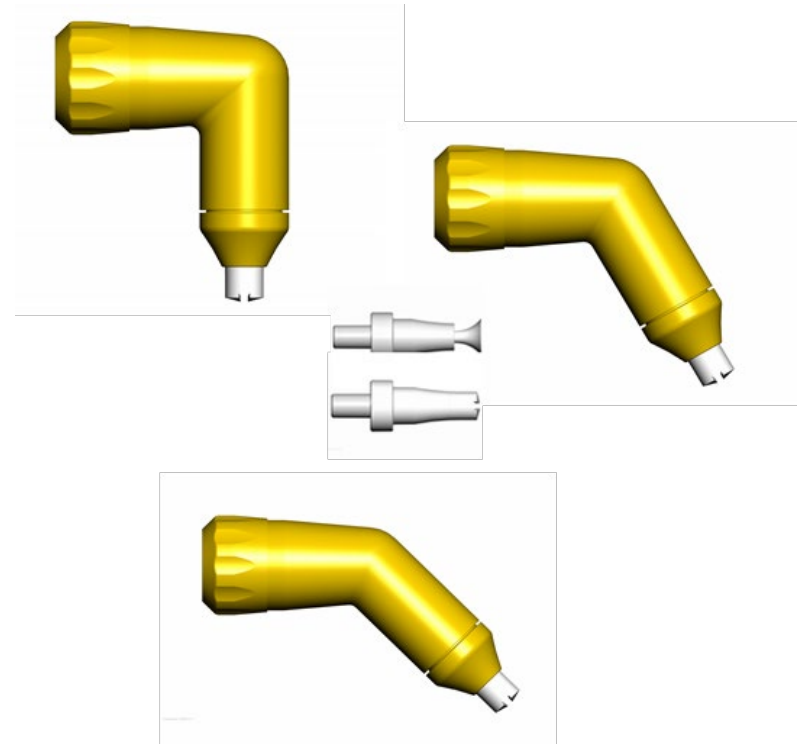

SuperCorona add-on to improve quality

- In a corona gun the high voltage electrode generates a big quantity of air ions
- Only a few air ions really charge the powder particles, the other ions remain free and are attracted by the surface to coat (which is grounded).
- The high accumulation of free ions on the surface to coat can produce an uneven powder layer and the so called "**orange peel effect**" or "**back-ionization**" problems.
- **SuperCorona** discharges the excessive free ions to ground and avoids overcharging of the powder and of the surface to coat.

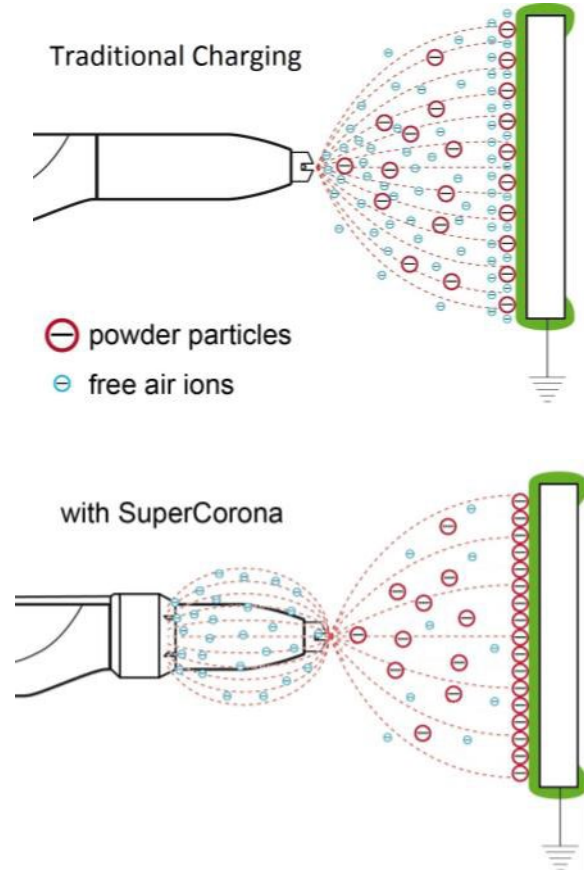

Flat jet nozzle / NF

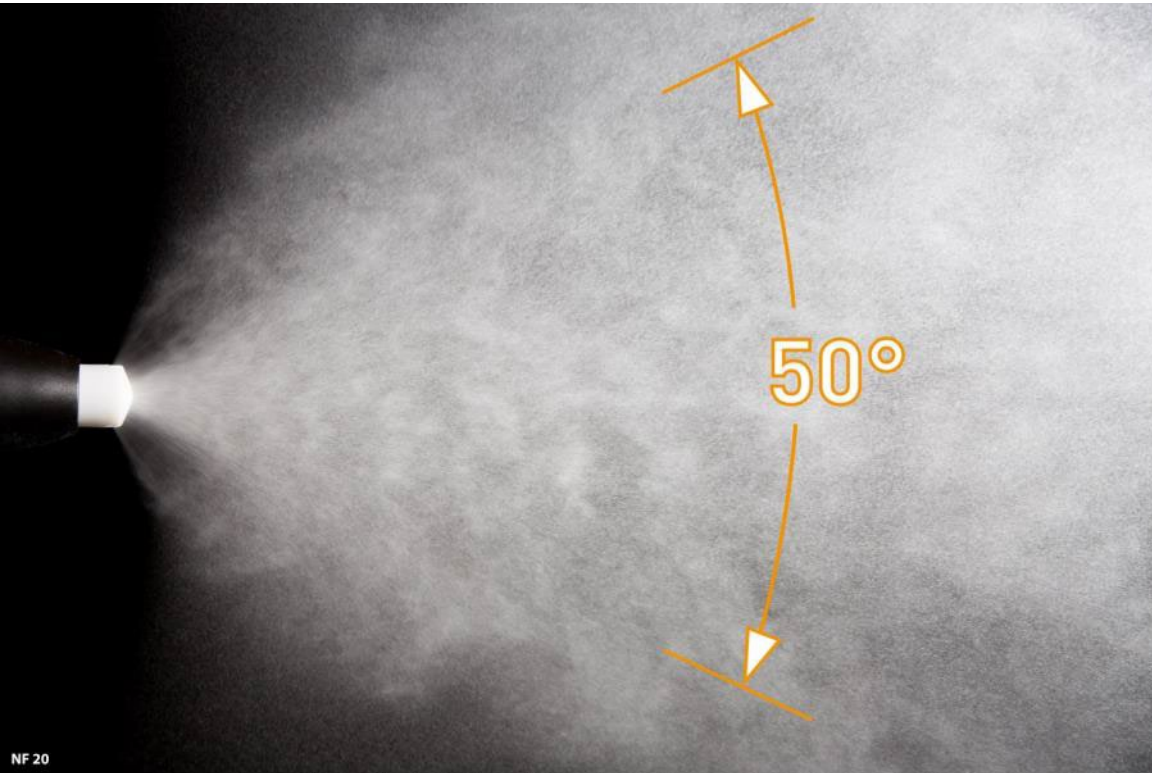

- Flat jet nozzle type **NF20**
- Standard for Gema manual guns
- Ordering references:
 - NF20 complete
(No. 1'010'160)
 - NF20 flat jet nozzle only
(No. 1'010'090)
- Field of application
 - Standard manual nozzle
 - Flat parts
 - Profiles
- Spray angle = 50°
- Velocity = moderate - low
- Target distance = max 250 mm

Flat jet nozzle / NF

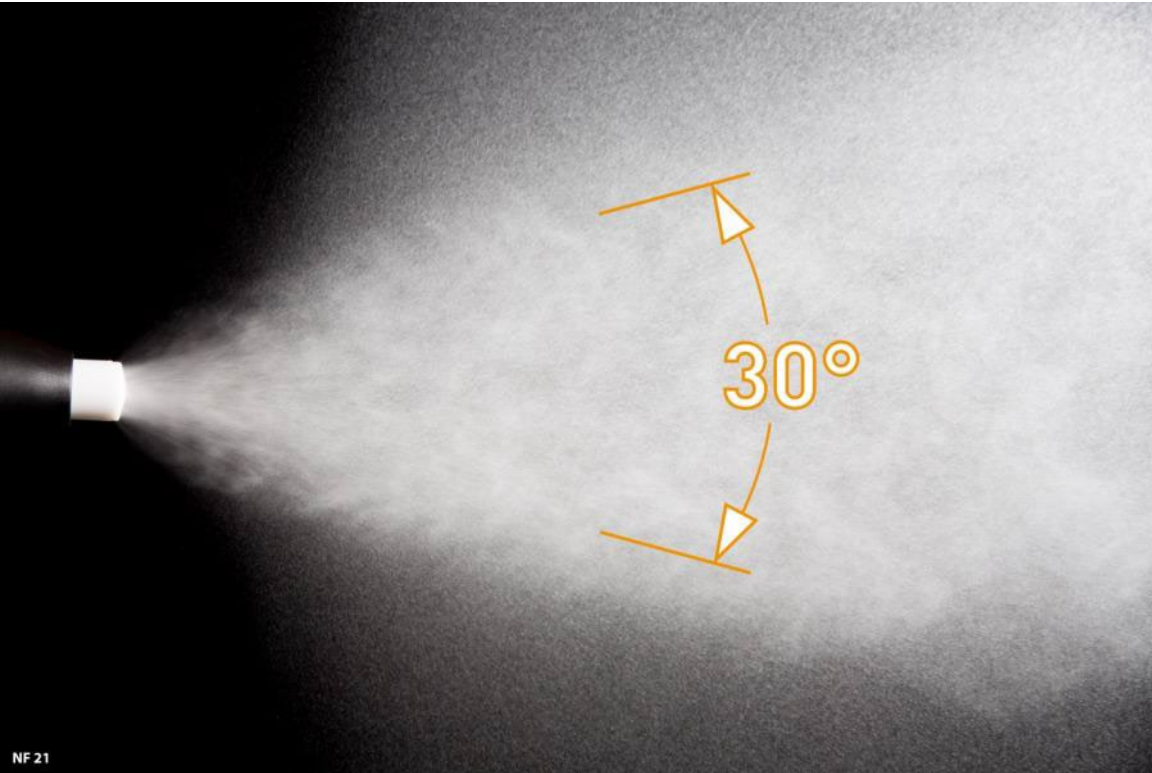

- Flat jet nozzle type **NF21**
- Ordering references:
 - NF21 complete
(No. 1'007'932)
 - NF21 flat jet nozzle only
(No. 1'007'935)
- Field of application
 - Automatic & manual nozzle
 - Complex parts (deep recess)
 - Target spraying
- Spray angle = 30°
- Velocity = high
- Target distance = max 400 mm

Flat jet nozzle / NF

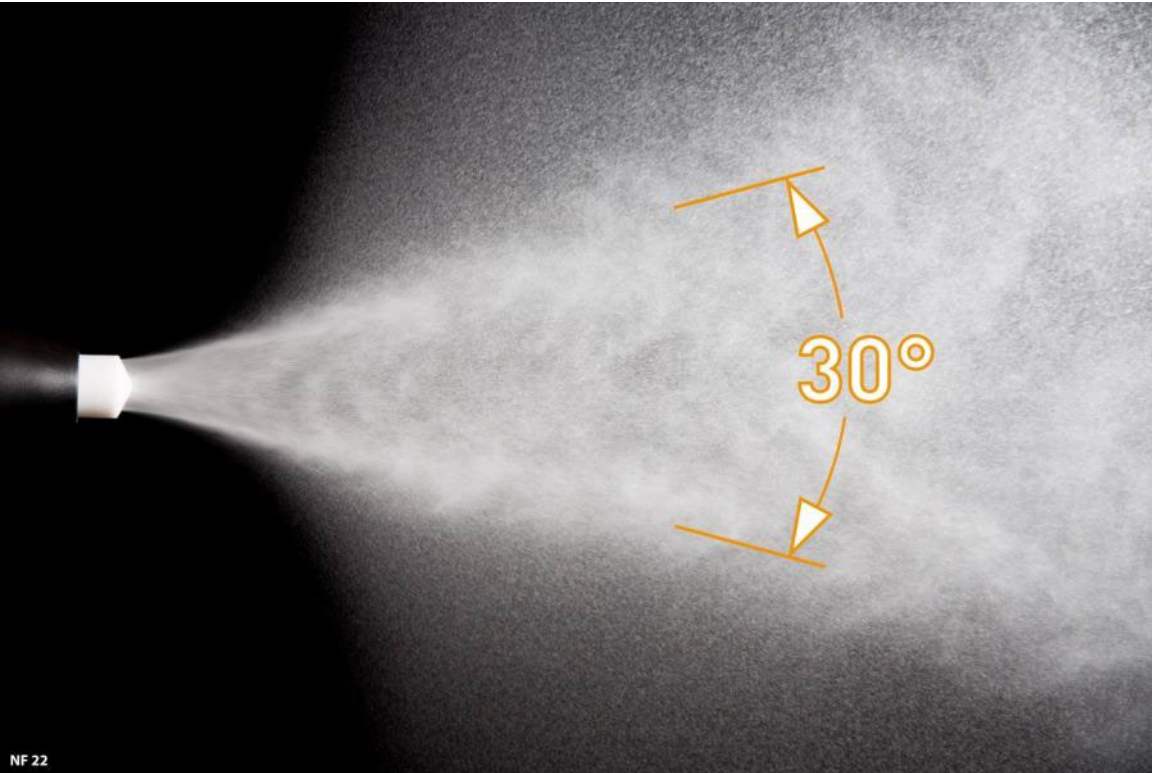

- Flat jet nozzle type **NF22**
- Ordering references:
 - NF22 complete
(No. 1'008'140)
 - NF22 flat jet nozzle only
(No. 1'008'145)
- Field of application
 - Automatic & manual nozzle
 - Complex parts (deep recess)
 - Target spraying
 - Robot applications
- Spray angle = 30°
- Velocity = high
- Target distance = max 450 mm

Flat jet nozzle / NF

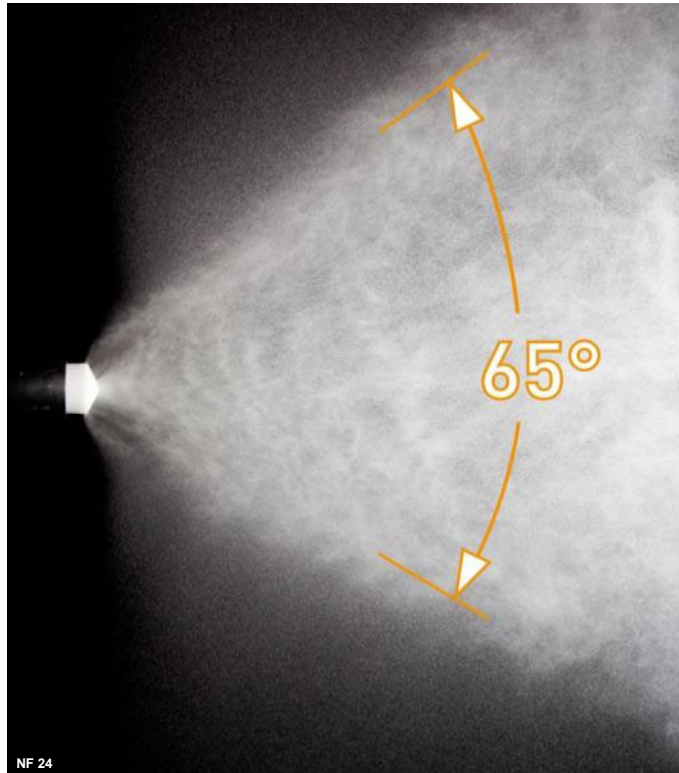

- Flat jet nozzle type **NF24**
- Ordering references:
 - NF24 complete
(No. 1'008'142)
 - NF24 flat jet nozzle only
(No. 1'008'147)
 - Remark: in combination
with threaded sleeve
Gema No. 1'008'326
- Field of application
 - Automatic & manual nozzle
 - Large object
 - Flat parts
 - Complex parts when nozzle
close to the object
- Spray angle = 65°
- Velocity = low
- Target distance = max 200 mm

Flat jet nozzle / NF

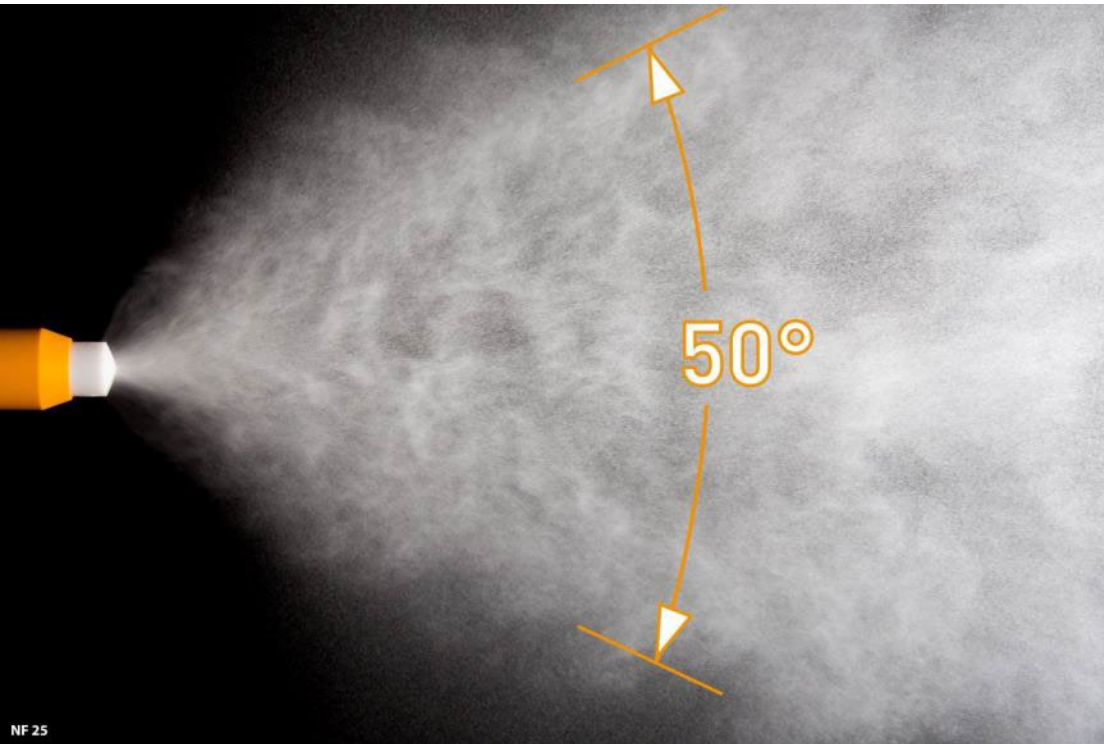

- Flat jet nozzle type **NF25** (mini)
- Ordering references:
 - NF25 complete
(No. 1'007'743)
 - NF25 flat jet nozzle only
(No. 1'007'735)
 - In combination with \varnothing 25 mm reduced diameter extension to penetrate into cavities
- Field of application
 - Powder cloud like NF20
 - Automatic & manual nozzle
 - Flat parts
 - Profiles
- Spray angle = 50°
- Velocity = moderate - low
- Target distance = max 250 mm

Flat jet nozzle / NF

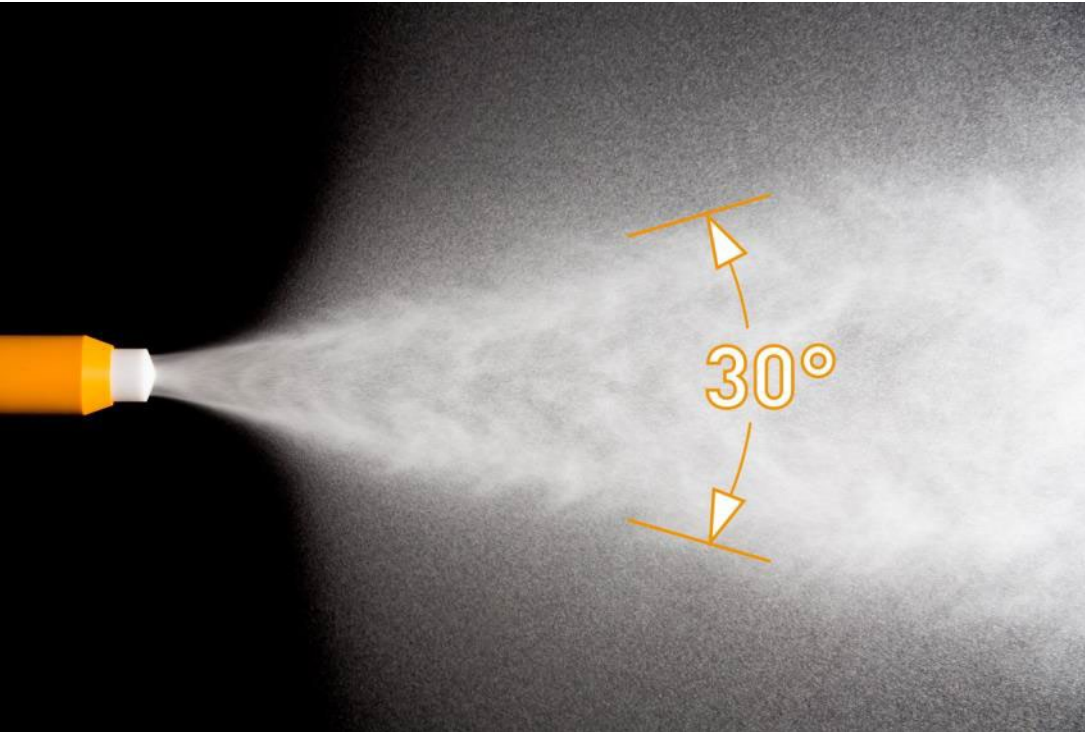

- Flat jet nozzle type **NF26** (mini)
- Ordering references:
 - NF26 complete (No. 1'007'744)
 - NF26 flat jet nozzle only (No. 1'007'742)
 - In combination with Ø 25 mm reduced diameter extension to penetrate into cavities
- Field of application
 - Powder cloud like NF22
 - Automatic & manual nozzle
 - Complex parts (deep recess)
 - Target spraying, Robot applications
- Spray angle = 30°
- Velocity = high
- Target distance = max 450 mm

Flat jet nozzle / NF

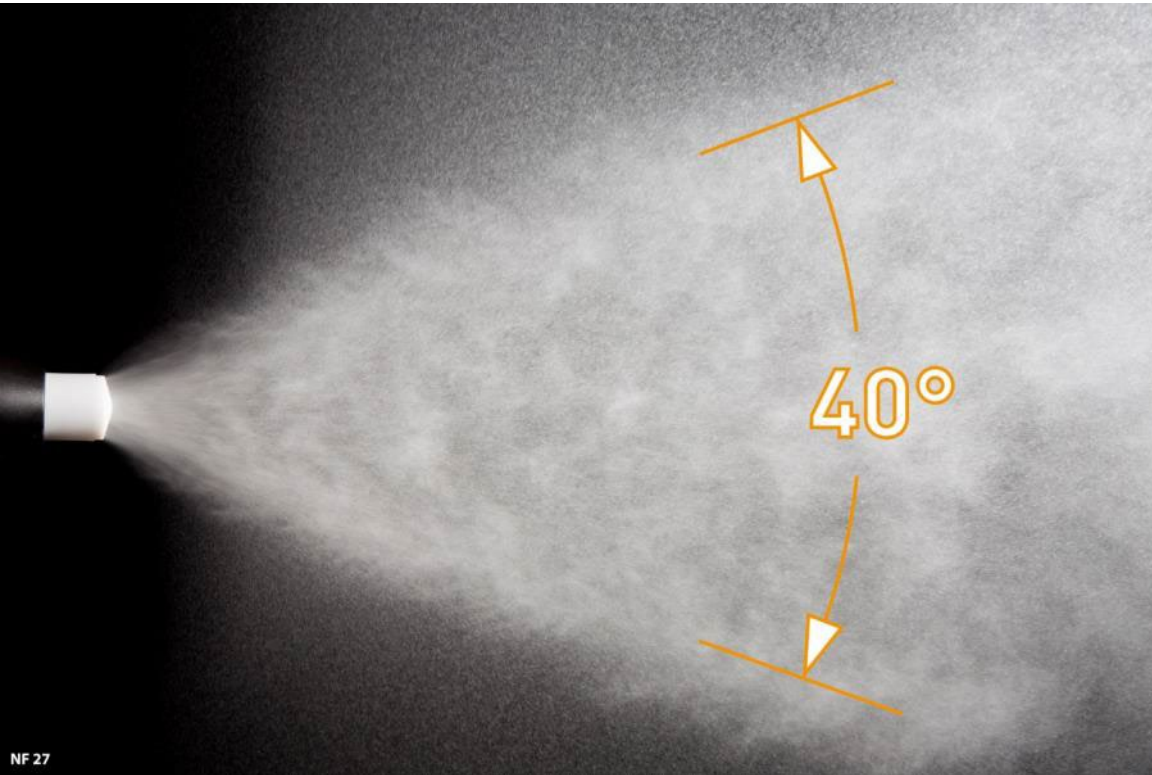

- Flat jet nozzle type **NF27**
- Standard for automatic guns
- Ordering references:
 - NF27 complete (No. 1'010'754)
 - NF27 flat jet nozzle only (No. 1'010'752)
- Field of application
 - Standard automatic nozzle
 - Profiles, complex parts
 - Flat parts
- Spray angle = 40°
- Velocity = high - moderate
- Target distance = max 350 mm
- Remark: Alternative for large flat objects or complex parts, when nozzle close to the object = NF24

Flat jet nozzle / NF

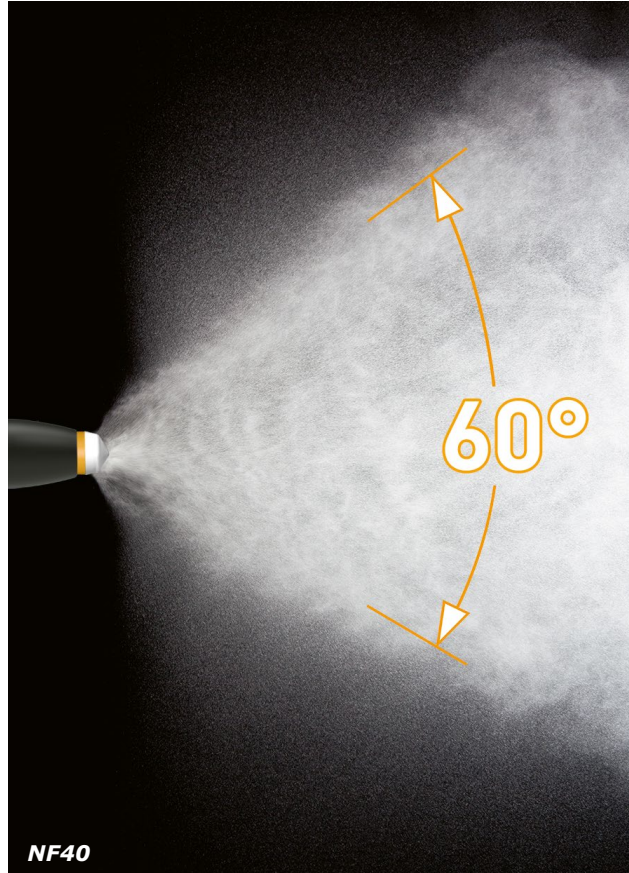

- Flat jet nozzle type **NF40** (PowerBoost)
- Ordering references:
 - NF40 complete (No. 1'018'166)
 - NF40 flat jet nozzle only (No. 1'018'165)
 - Remark: In combination with threaded sleeve Gema No. 1'008'326
- Field of application
 - Manual nozzle
 - Large object
 - Flat parts
 - Complex parts when nozzle close to the object
- Spray angle = 60°
- Velocity = moderate - low
- Target distance = max 250 mm

Round jet nozzle / NS

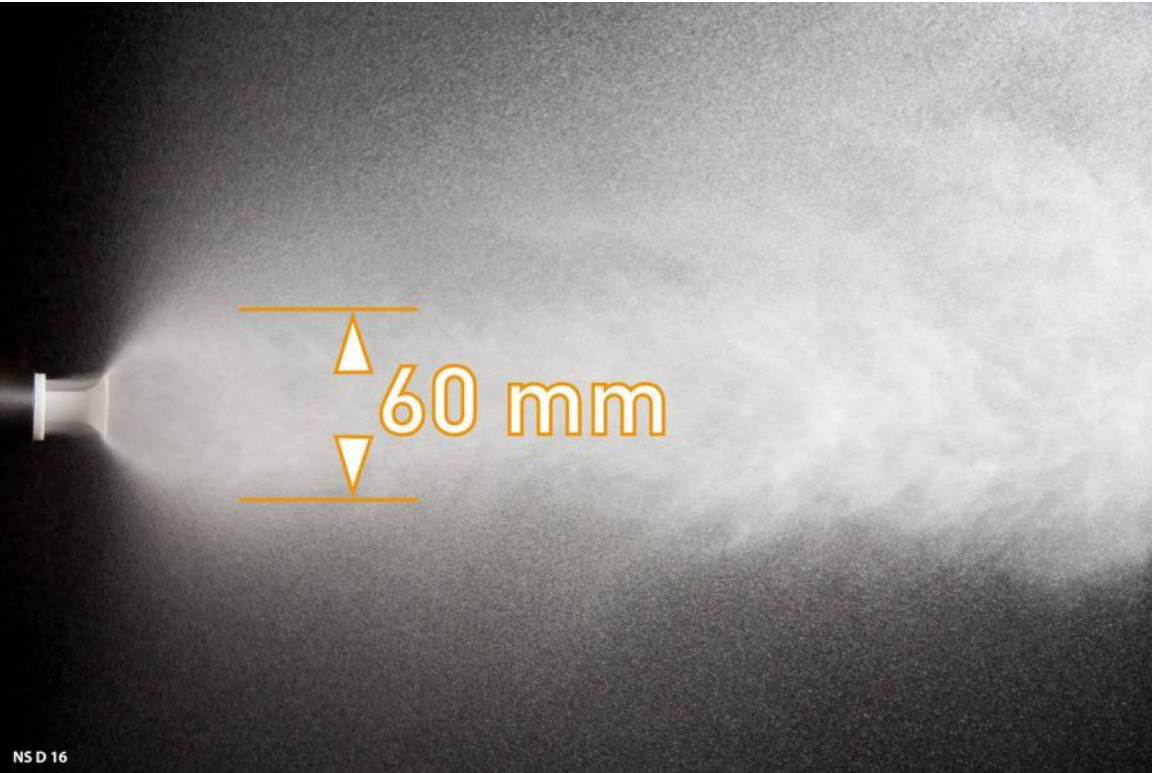

- Round spray nozzle type **NS**
- Ordering references:
 - NS04 (No. 1'008'150), or
 - NS09 mini (No. 1'008'259)
 - Deflector only **Ø16** mm (No. 331'341)
- Field of application
 - Automatic & manual nozzle
 - Flat parts
 - Low speed coating
- Max powder cloud = Ø 60mm
- Velocity = low
- Target distance = max 120 mm

Round jet nozzle / NS

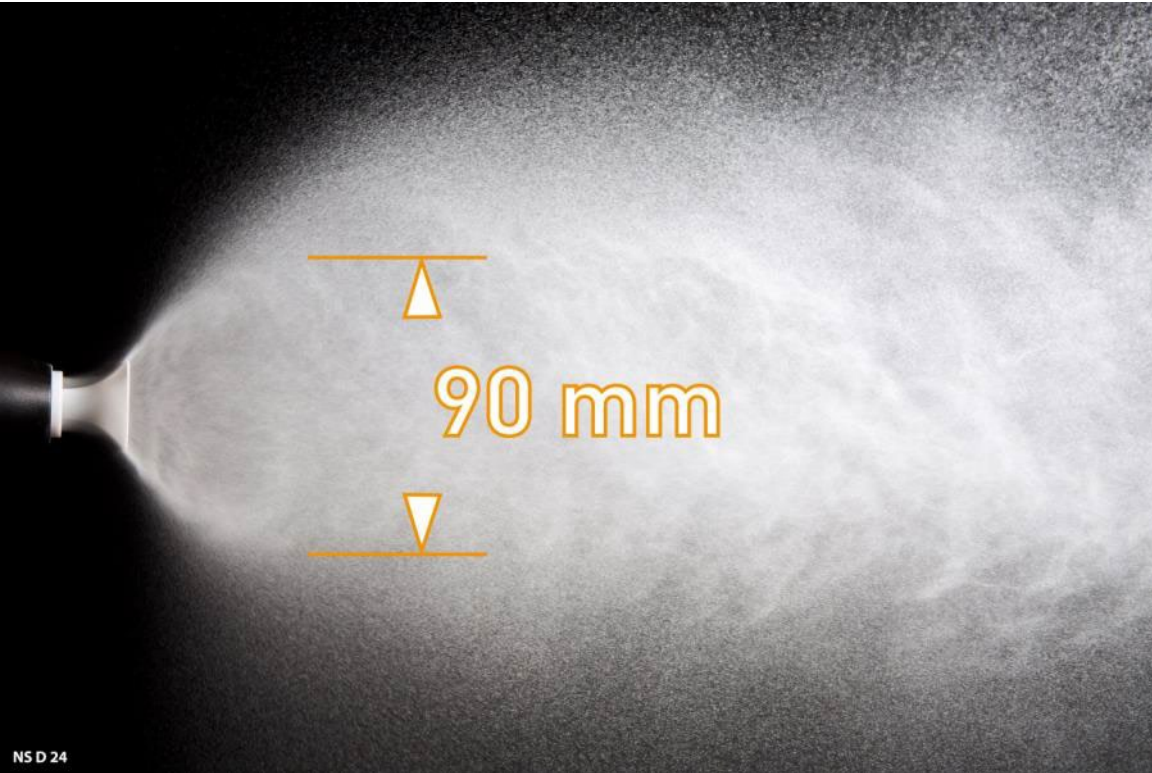

- Round spray nozzle type **NS**
- Ordering references:
 - NS04 (No. 1'008'150), or
 - NS09 mini (No. 1'008'259)
 - Deflector only **Ø24** mm (No. 331'333)
- Field of application
 - Automatic & manual nozzle
 - Flat parts
 - Low speed coating
- Max powder cloud = Ø 90mm
- Velocity = low
- Target distance = max 160 mm

Round jet nozzle / NS

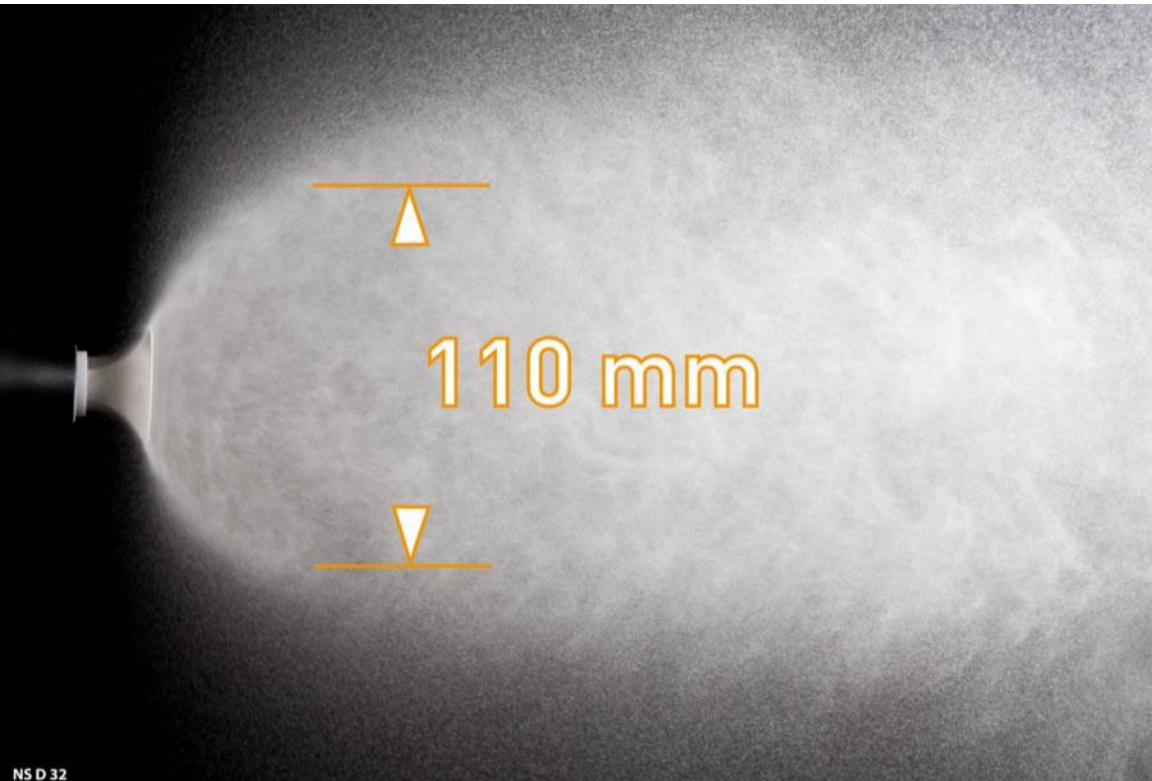

- Round spray nozzle type **NS**
- Ordering references:
 - NS04 (No. 1'008'150)
 - NS09 mini (No. 1'008'259)
 - Deflector only **Ø32** mm (No. 331'325)
- Field of application
 - Automatic & manual nozzle
 - Flat parts
 - Low speed coating
- Max powder cloud = Ø 110 mm
- Velocity = low
- Target distance = max 160 mm

Round jet nozzle / NS

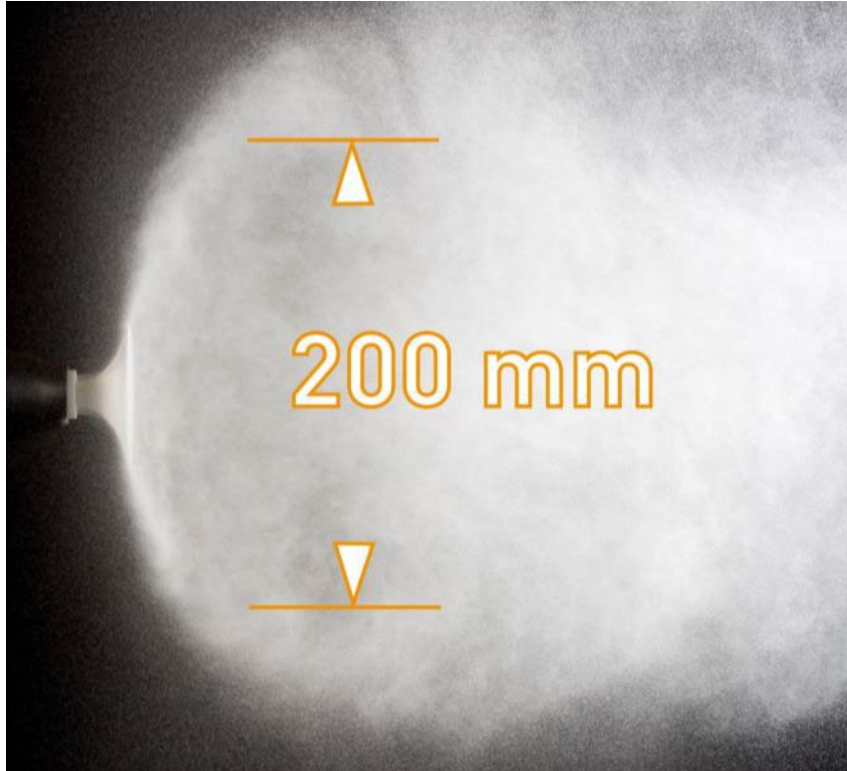

- Round spray nozzle type **NS**
- Ordering references:
 - NS04 (No. 1'008'150)
 - NS09 mini (No. 1'008'259)
 - Deflector only **Ø50** mm (No. 345'822)
- Field of application
 - Automatic & manual nozzle
 - Flat parts
 - Low speed coating
- Max powder cloud = Ø 200 mm
- Velocity = low
- Target distance = max 180 mm

Comparison

NF 20 standard for manual $\alpha = 50^\circ$

NF 27 standard for automatic $\alpha = 40^\circ$

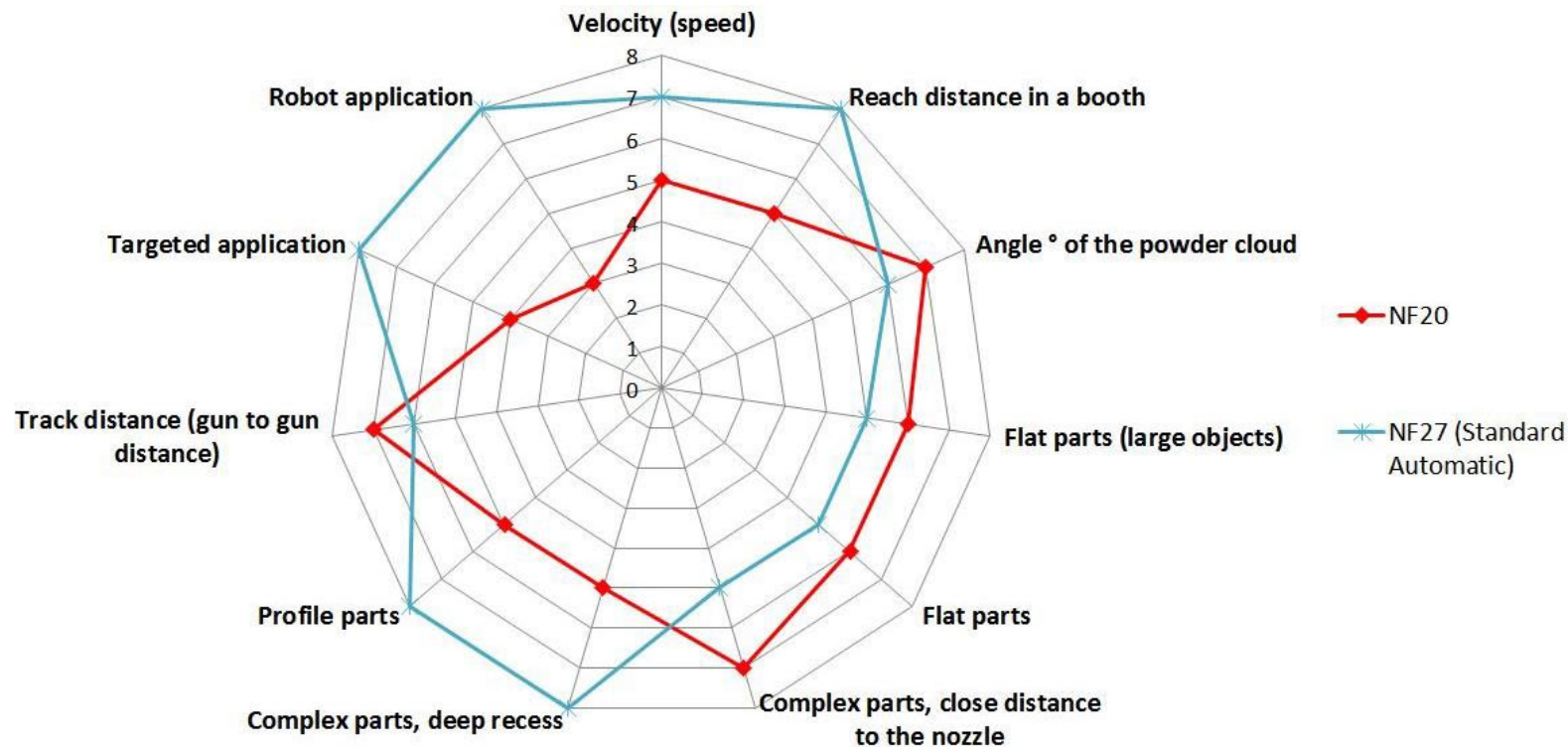

Comparison

NF 21 $\alpha = 30^\circ$
NF 24 $\alpha = 65^\circ$

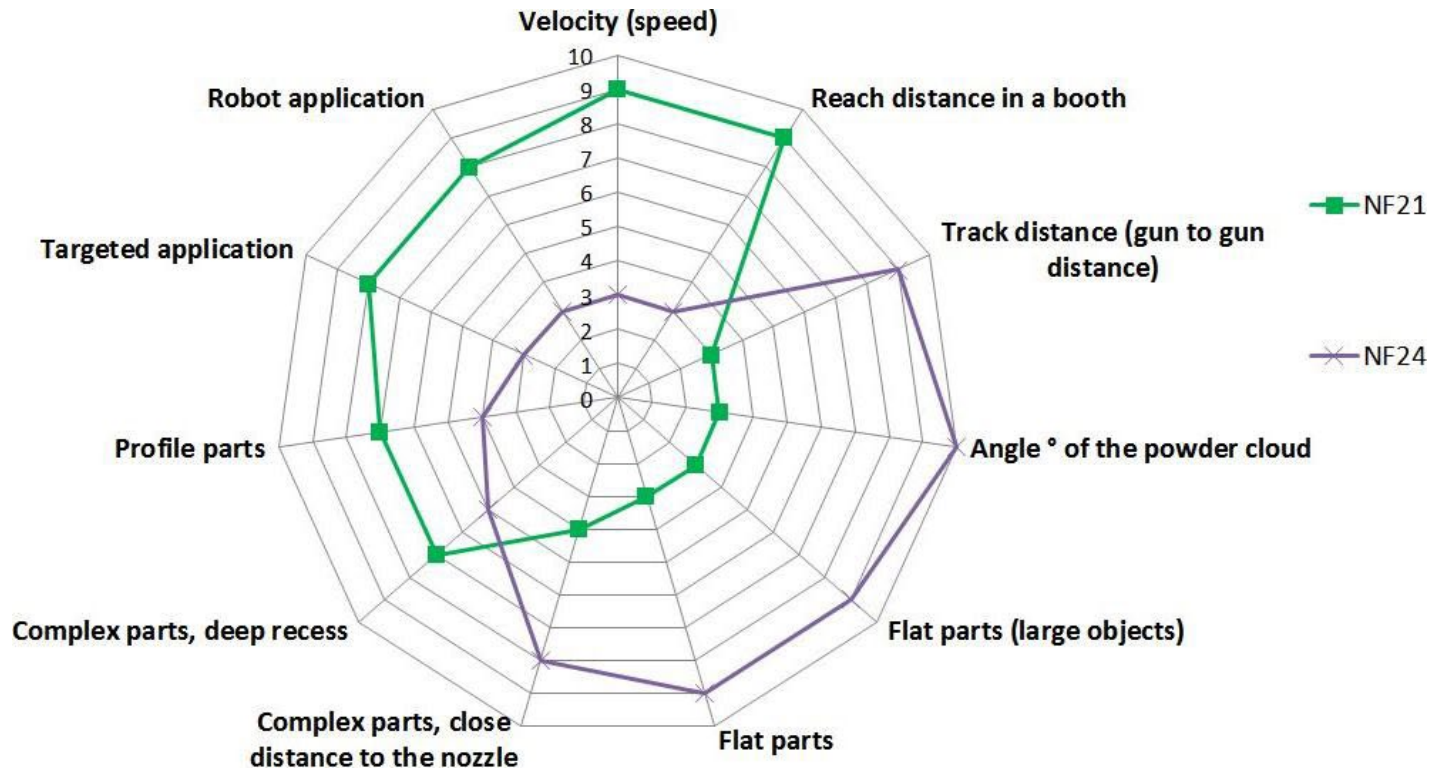

Nozzle Assortment overview

NOZZLE ASSORTMENT for the OptiSelect® Pro [GM04] / OptiSelect® (GM03) and the OptiGun® (GA03)



Nozzle type	NF20	NF21	NF22	NF24	NF25 [mini]	NF26 [mini]	NF27	NF40 PowerBoost®	NS04	NS09 [mini]		
Gema No. with electrode holder	1'010'160	1'007'932	1'008'140	1'008'142	1'007'743	1'007'744	1'010'754	1'018'166	1'008'150	1'008'259		
Gema No. without electrode holder (nozzle only)	1'010'090	1'007'935	1'008'145	1'008'147	1'007'735	1'007'742	1'010'752	1'018'165	1'008'151	1'008'257		
	MultiSpray Adapter further matching accessories								Deflector			
	1'003'634	×	×	×	1'003'634	×	1'003'634	×	331 341	331 333	331 325	345 822
									Ø 16mm	Ø 24 mm	Ø 32 mm	Ø 50mm
Powder cloud												
Gun Typ applicable for	GM03/ GA03 GM04	GM03/ GA03 GM04	GM03/ GA03 GM04	GM03/ GA03 GM04	GM03/ GA03 GM04	GM03/ GA03 GM04	GM03/ GA03 GM04	GM04	GM03/ GA03 GM04	GM03/ GA03 GM04	GM03/ GA03 GM04	GM03/ GA03 GM04
Application	Flat parts, profiles, manual applications	Complex parts deep recess, target spraying	Complex parts deep recess, target spraying, robot applications	Large objects, flat parts, manual applications as well as complex parts, when nozzle close to the object	Flat parts, profiles, manual applications	Complex parts deep recess, target spraying, robot applications	Profiles, complex parts, flat parts	Large objects, flat parts, manual applications as well as complex parts, when nozzle close to the object				
Powder cloud α°/Ø	50°	30°	30°	65°	50°	30°	40°	60°	Ø 60 mm	Ø 90 mm	Ø 110 mm	Ø 200 mm
Performance speed <small>Air setting Ø [4 Nm³/h]</small>	moderate - low	high	high	low	moderate - low	high	high - moderate	moderate - low	low	low	low	low
Reach distance max. <small>automatic application Air settings Ø [4 Nm³/h]</small>	250 mm	400 mm	450 mm	200 mm	250 mm	450 mm	350 mm	250 mm	120 mm	160 mm	160 mm	180 mm
Remark				Only in combination with threaded sleeve Gema Nr. 1'008'326	In combination with extension Ø 25mm, reduced diameter to penetrate into cavities powder cloud like NF20	In combination with extension Ø 25mm, reduced diameter to penetrate into cavities powder cloud like NF22	Limitation: NF27 requires a minimal clearance between object and nozzle	Only in combination with threaded sleeve Gema Nr. 1'008'326			In combination with extension Ø 25mm, reduced diameter to penetrate into cavities	