

---

Operating instructions and spare parts list

# OptiFlex A2 Control system (AS04 type)

**TW**  
**Gema**



**Documentation OptiFlex A2 Control system**

© Copyright 2005 ITW Gema AG

All rights reserved.

This publication is protected by copyright. Unauthorized copying is prohibited by law. No part of this publication may be reproduced, photocopied, translated, stored on a retrieval system or transmitted in any form or by any means for any purpose, neither as a whole nor partially, without the express written consent of ITW Gema AG.

OptiTronic, OptiGun, EasyTronic, EasySelect, OptiFlow and Super-Corona are registered trademarks of ITW Gema AG.

OptiMatic, OptiMove, OptiMaster, OptiPlus, MultiTronic and Gematic are trademarks of ITW Gema AG.

All other product names are trademarks or registered trademarks of their respective holders.

Reference is made in this manual to different trademarks or registered trademarks. Such references do not mean that the manufacturers concerned approve of or are bound in any form by this manual. We have endeavored to retain the preferred spelling of the trademarks, and registered trademarks of the copyright holders.

To the best of our knowledge and belief, the information contained in this publication was correct and valid on the date of issue. ITW Gema AG makes no representations or warranties with respect to the contents or use of this publication, and reserves the right to revise this publication and make changes to its content without prior notice.

**Printed in Switzerland**

ITW Gema AG  
Mövenstrasse 17  
9015 St. Gallen  
Switzerland

Phone: +41-71-313 83 00  
Fax.: +41-71-313 83 83

E-Mail: [info@itwgema.ch](mailto:info@itwgema.ch)  
Homepage: [www.itwgema.ch](http://www.itwgema.ch)

# Table of contents

<b>General safety regulations</b>	<b>3</b>
Safety symbols (pictograms).....	3
Conformity of use.....	3
Technical safety regulations for stationary electrostatic powder spraying equipment .....	4
General information .....	4
Safety conscious working .....	5
Individual safety regulations for the operating firm and/or operating personnel .....	5
Notes on special types of hazard.....	6
Safety requirements for electrostatic powder coating.....	7
A summary of the rules and regulations .....	8
Product specific security measures .....	10
<b>About this manual</b>	<b>11</b>
General information .....	11
<b>Function description</b>	<b>13</b>
Field of application .....	13
Scope of delivery .....	13
OptiFlex A2 Control system - components .....	14
OptiFlex A2 Control system - possible configurations .....	15
Automatic equipment .....	15
Automatic equipment with superordinated control unit.....	15
<b>Technical data</b>	<b>17</b>
OptiFlex A2 Control system .....	17
Electrical data .....	17
Pneumatic data .....	17
Control cabinet dimensions.....	17
ICS cabinet dimensions .....	18
<b>Start-up</b>	<b>19</b>
Setup and assembly .....	19
Assembly notes.....	19
Configuration.....	19
OptiFlex A2 Control system .....	20
OptiFlex A2 Control system with CM-20.....	20
OptiFlex A2 Control system with CM-10 Magic Control .....	21
Procedure for initial start up .....	21
General information .....	21
Power supply.....	21
Compressed air.....	22
<b>Schematic diagrams</b>	<b>23</b>

OptiFlex A2 Control system - pneumatical diagram .....	23
<b>Spare parts list</b>	<b>25</b>
Ordering spare parts.....	25
OptiFlex A2 control cabinet - spare parts list.....	26
OptiFlex A2 control cabinet - spare parts .....	27
OptiFlex A2 - mounting plate.....	28
OptiFlex A2 - mounting plate.....	29

# General safety regulations

This chapter sets out the fundamental safety regulations that must be followed by the user and third parties using the OptiFlex A2 Control system.

These safety regulations must be read and understood before the OptiFlex A2 Control system is used.

---

## Safety symbols (pictograms)

The following warnings with their meanings can be found in the ITW Gema operating instructions. The general safety precautions must also be followed as well as the regulations in the operating instructions.

**DANGER!**

Danger due to live electricity or moving parts. Possible consequences: Death or serious injury

**WARNING!**

Improper use of the equipment could damage the machine or cause it to malfunction. Possible consequences: minor injuries or damage to equipment

**INFORMATION!**

Useful tips and other information



---

## Conformity of use

1. The OptiFlex A2 Control system is built to the latest specification and conforms to the recognized technical safety regulations. It is designed for the normal application of powder coating.
2. Any other use is considered as non-conform. The manufacturer is not responsible for damage resulting from improper use of this equipment; the end-user alone is responsible. If the OptiFlex A2 Control system is to be used for other purposes or other substances outside of our guidelines then ITW Gema AG should be consulted.
3. Observance of the operating, service and maintenance instructions specified by the manufacturer is also part of conformity of use. The OptiFlex A2 Control system should only be used, main-

tained and started up by trained personnel, who are informed about and are familiar with the possible hazards involved.

4. Start-up (i.e. the execution of a particular operation) is forbidden until it has been established that the OptiFlex A2 Control system has been set up and wired according to the guidelines for machinery (98/37 EG). EN 60204-1 (machine safety) must also be observed.
5. Unauthorized modifications to OptiFlex A2 Control system exempts the manufacturer from any liability from resulting damage.
6. The relevant accident prevention regulations, as well as other generally recognized safety regulations, occupational health and structural regulations are to be observed.
7. Furthermore the country-specific safety regulations must be observed.

Explosion protection	Protection type	Temperature class
  0102 II 2 D	IP54	T6 (zone 21) T4 (zone 22)

## Technical safety regulations for stationary electrostatic powder spraying equipment

### General information

The powder spraying equipment from ITW Gema is designed with safety in mind and is built according to the latest technological specifications. This equipment can be dangerous if it is not used for its specified purpose. Consequently it should be noted that there exists a danger to life and limb of the user or third party, a danger of damage to the equipment and other machinery belonging to the user and a hazard to the efficient operation of the equipment.

1. The powder spraying equipment should only be started up and used once the operating instructions have been carefully studied. Improper use of the controlling device can lead to accidents, malfunction or damage to the control itself.
2. Before every start-up check the equipment for operational safety (regular servicing is essential)!
3. Safety regulations BGI 764 and VDE regulations DIN VDE 0147, Part 1, must be observed for safe operation.
4. Safety precautions specified by local legislation must be observed.
5. The plug must be disconnected before the machine is opened for repair.
6. The plug and socket connection between the powder spraying equipment and the mains network should only be taken out when the power is switched off.
7. The connecting cable between the controlling device and the spray gun must be set up so that it cannot be damaged during operation. Safety precautions specified by local legislation must be observed!

8. Only original ITW-Gema spare parts should be used, because the explosion protection will also be preserved that way. Damage caused by other parts is not covered by guarantee.
9. If ITW-Gema powder spraying equipment is used in conjunction with machinery from other manufacturers then their safety regulations must also be taken into account.
10. Before starting work familiarize yourself with all installations and operating elements, as well as with their functions! Familiarization during operation is too late!
11. Caution must be exercised when working with a powder/air mixture! A powder/air mixture in the right concentration is flammable! Smoking is forbidden in the entire plant area!
12. As a general rule for all powder spraying installations, persons with pacemakers should never enter high voltage areas or areas with electromagnetic fields. Persons with pacemakers should not enter areas with powder spraying installations!

**WARNING!**

**We emphasize that the customer himself is responsible for the safe operation of equipment. ITW-Gema is in no way responsible for any resulting damages!**

## Safety conscious working

Each person responsible for the assembly, start-up, operation, service and repair of powder spraying equipment must have read and understood the operating instructions and the "Safety regulations"-chapter. The operator must ensure that the user has had the appropriate training for powder spraying equipment and is aware of the possible sources of danger.

The control devices for the spray guns must only be set up and used in zone 22. Only the spray gun should be used in zone 21.

The powder spraying equipment should only be used by trained and authorized personnel. This applies to modifications to the electrical equipment, which should only be carried out by a specialist.

The operating instructions and the necessary closing down procedures must be followed before any work is carried out concerning the set-up, start-up, operation, modification, operating conditions, mode of operation, servicing, inspection or repairs.

The powder spray equipment can be turned off by using the main switch or failing that, the emergency shut-down. Individual components can be turned off during operation by using the appropriate switches.

## Individual safety regulations for the operating firm and/or operating personnel

1. Any operating method which will negatively influence the technical safety of the powder spraying equipment is to be avoided.
2. The operator should care about no non-authorized personnel works on the powder spraying equipment (e.g. this also includes using the equipment for non-conform work).
3. For dangerous materials, the employer has to provide an operating instructions manual for specifying the dangers arising for hu-

mans and environment by handling dangerous materials, as well as the necessary preventive measures and behavior rules. The operating instructions manual has to be written in an understandable form and in the language of the persons employed, and has to be announced in a suitable place in the working area.

4. The operator is under obligation to check the powder spraying equipment at least once every shift for signs of external damage, defects or changes (including the operating characteristics) which could influence safety and to report them immediately.
5. The operator is obliged to check that the powder spraying equipment is only operated when in satisfactory condition.
6. As far as it is necessary, the operating firm must ensure that the operating personnel wear protective clothing (e.g. facemasks).
7. The operating firm must guarantee cleanliness and an overview of the workplace with suitable instructions and checks in and around the powder spraying equipment.
8. No safety devices should be dismantled or put out of operation. If the dismantling of a safety device for set-up, repair or servicing is necessary, reassembly of the safety devices must take place immediately after the maintenance or repair work is finished. The powder spraying device must be turned off while servicing is carried out. The operator must train and commit the responsible personnel to this.
9. Activities such as checking powder fluidization or checking the high-voltage spray gun etc. must be carried out with the powder spraying equipment switched on.

## **Notes on special types of hazard**

### ***Power***

It is necessary to refer once more to the danger of life from high-voltage current if the shut-down procedures are not observed. High voltage equipment must not be opened - the plug must first be taken out - otherwise there is danger of electric shock.

### ***Powder***

Powder/air mixtures can be ignited by sparks. There must be sufficient ventilation in the powder coating booth. Powder lying on the floor around the powder spraying device is a potentially dangerous source of slipping.

### ***Static charges***

Static charges can have the following consequences: Charges to people, electric shocks, sparking. Charging of objects must be avoided - see "Earthing".

### ***Grounding/Earthing***

All electricity conducting parts and machinery found in the workplace (according to DIN VDE 0745, part 102) must be earthed 1.5 meters either side and 2.5 meters around each booth opening. The earthing resistance must amount to maximally 1 MOhm. The resistance must be tested on a regular basis. The condition of the machinery surroundings as well as the suspension gear must ensure that the machinery remains earthed. If the earthing of the machinery includes the suspension arrangements, then



these must constantly be kept clean in order to guarantee the necessary conductivity. The appropriate measuring devices must be kept ready in the workplace in order to check the earthing.

### ***Compressed air***

When there are longer pauses or stand-still times between working, the powder spraying equipment should be drained of compressed air. There is a danger of injury when pneumatic hoses are damaged and from the uncontrolled release and improper use of compressed air.

### ***Crushing and cutting***

During operation, moving parts may automatically start to move in the operating area. It must be ensured that only instructed and trained personnel go near these parts. The operator should ensure that barriers comply with the local security regulations.

### ***Access under exceptional circumstances***

The operating firm must ensure that local conditions are met when repairs are made to the electronic parts or when the equipment is restarted so that there are additional measures such as barriers to prevent unauthorized access.

### ***Prohibition of unauthorized conversions and modifications to machines***

All unauthorized conversions and modifications to electrostatic spraying equipment are forbidden for safety reasons.

The powder spraying equipment should not be used if damaged, the faulty part must be immediately replaced or repaired. Only original ITW-Gema replacement parts should be used. Damage caused by other parts is not covered by guarantee.

Repairs must only be carried out by specialists or in ITW-Gema workshops. Unauthorized conversions and modifications may lead to injury or damage to machinery. The ITW Gema AG guarantee would no longer be valid.

## **Safety requirements for electrostatic powder coating**

1. This equipment is dangerous if the instructions in this operating manual are not followed.
2. All electrostatic conductive parts, in particular the machinery within 5 meters of the coating equipment, must be earthed.
3. The floor of the coating area must conduct electricity (normal concrete is generally conductive).
4. The operating personnel must wear electricity conducting footwear (e.g. leather soles).
5. The operating personnel should hold the gun with bare hands. If gloves are worn, these must also conduct electricity.
6. The supplied earthing cable (green/yellow) must be connected to the earthing screw of the electrostatic powder spraying hand appliance. The earthing cable must have a good metallic connection with the coating booth, the recovery unit and the conveyor chain and with the suspension arrangement of the objects.

7. The electricity and powder supply to the hand guns must be set up so that they are fully protected against heat and chemical damage.
8. The powder coating device may only be switched on once the booth has been started up. If the booth cuts out then the powder coating device must be switched off.
9. The earthing of all electricity conducting devices (e.g. hooks, conveyor chains) must be checked on a weekly basis. The earthing resistance must amount to maximally 1 MOhm.
10. The control device must be switched off if the hand gun is cleaned or the nozzle is changed.
11. When working with cleaning agents there may be a risk of hazardous fumes. The manufacturers instructions must be observed when using such cleaning agents.
12. The manufacturers instructions and the applicable environmental requirements must be observed when disposing of powder lacquer and cleaning agents.
13. If any part of the spray gun is damaged (broken parts, tears) or missing then it should not be used.
14. For your own safety, only use accessories and attachments listed in the operating instructions. The use of other parts can lead to risk of injury. Only original ITW-Gema replacement parts should be used.
15. Repairs must only be carried out by specialists and under no circumstances should they be carried out in the operating area. The former protection must not be reduced.
16. Conditions leading to dangerous levels of dust concentration in the powder spraying booths or in the powder spraying areas must be avoided. There must be sufficient technical ventilation available, to prevent a dust concentration of more than 50% of the lower explosion limit (UEG) (UEG = max. permissible powder/air concentration). If the UEG is not known then a value of 10 g/m<sup>3</sup> should be used.

## A summary of the rules and regulations

The following is a list of relevant rules and regulations which are to be observed:

### ***Guidelines and regulations, German professional association***

BGV A1	General regulations
BGV A2	Electrical equipment and material
BGI 764	Electrostatic coating
BGR 132	Guidelines for the avoidance of the dangers of ignition due to electrostatic charging (Guideline "Static Electricity")
VDMA 24371	Guidelines for electrostatic coating with synthetic powder <sup>1)</sup> - Part 1 General requirements - Part 2 Examples of use

### Leaflets

ZH 1/310	Leaflet for the use of tools in locations where there is danger of explosion <sup>1)</sup>
----------	--------------------------------------------------------------------------------------------

### EN European standards

RL94/9/EC	The approximation of the laws of the Member States relating to apparatus and safety systems for their intended use in potentially explosive atmospheres
EN 292-1 EN 292-2	Machine safety <sup>2)</sup>
EN 50 014 to EN 50 020, identical: DIN VDE 0170/0171	Electrical equipment for locations where there is danger of explosion <sup>3)</sup>
EN 50 050	Electrical apparatus for potentially explosive atmospheres - Electrostatic hand-held spraying equipment <sup>2)</sup>
EN 50 053, part 2	Requirements for the selection, installation and use of electrostatic spraying equipment for flammable materials - Hand-held electrostatic powder spray guns <sup>2)</sup>
EN 50 177	Stationary electrostatic spraying equipment for flammable coating powder <sup>2)</sup>
PR EN 12981	Coating plants - Spray booths for application of organic powder coating material - Safety requirements
EN 60 529, identical: DIN 40050	IP-Type protection: contact, foreign bodies and water protection for electrical equipment <sup>2)</sup>
EN 60 204 identical: DIN VDE 0113	VDE regulations for the setting up of high-voltage electrical machine tools and processing machines with mains voltages up to 1000 V <sup>3)</sup>

### VDE (Association of German Engineers) Regulations

DIN VDE 0100	Regulations for setting-up high voltage equipment with mains voltages up to 1000 V <sup>4)</sup>
DIN VDE 0105 part 1 part 4	VDE regulations for the operation of high voltage equipment <sup>4)</sup> General regulations Supplementary definitions for stationary electrical spraying equipment
DIN VDE 0147 part 1	Setting up stationary electrostatic spraying equipment <sup>4)</sup>
DIN VDE 0165	Setting up electrical equipment in locations in areas with danger of explosion <sup>4)</sup>

#### \*Sources:

<sup>1)</sup> Carl Heymanns Verlag KG, Luxemburger Strasse 449, 5000 Köln 41, or from the appropriate employers association

<sup>2)</sup> Beuth Verlag GmbH, Burgrafenstrasse 4, 1000 Berlin 30

<sup>3)</sup> General secretariat, Rue Bréderode 2, B-1000 Bruxelles, or the appropriate national committee

<sup>4)</sup> VDE Verlag GmbH, Bismarckstrasse 33, 1000 Berlin 12

---

## Product specific security measures

- The installation work, to be done by the customer, must be carried out according to local regulations
- Before starting up the plant a check must be made that no foreign objects are in the booth or in the ducting (input and exhaust air)
- It must be observed, that all components are grounded according to the local regulations, before start-up

# About this manual

---

## General information

This operating manual contains all the important information which you require for the working with the OptiFlex A2 Control system. It will safely guide you through the start-up process and give you references and tips for the optimal use of your new powder coating system.

Information about the function mode of the individual system components - reciprocators, booths, powder gun controls, powder guns etc. - should be referenced to their corresponding documents.



# Function description

---

## Field of application

The OptiFlex A2 Control system with the ITW-Gema automatic powder guns was especially designed to meet the requirements of serial production in industry, where reliability in automated operation, easy to handle operation and security are the most projecting advantages for the user.

The flexible, modular structure of the OptiFlex A2 is readily adaptable to any modifications in the installation.

---

## Scope of delivery







The scope of delivery depends on the type and the number of installed control units (see therefore chapter "OptiFlex A2 Control system - components").

## OptiFlex A2 Control system - components



**Note:**

These components are assembled according to client's plant specifications. Further information about the components will be found in the corresponding operating manuals!

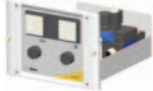
OptiFlex A2 control cabinet	Function
	<ul style="list-style-type: none"> <li>- Equipment main switch</li> <li>- Air supply</li> <li>- Max. 14 places for gun or axle control units per control cabinet</li> <li>- Option: Master control unit for the complete integration of the plant into the production process by CAN bus</li> </ul>
OptiStar CG06 Gun control unit	Function
	<ul style="list-style-type: none"> <li>- OptiStar CG06 standard gun control unit</li> <li>- Max. 250 stored programs possible</li> <li>- DVC (Digital Valve Control)</li> <li>- Option: CAN bus</li> </ul>
OptiMove CR06 Axes control unit	Function
	<ul style="list-style-type: none"> <li>- Axes control unit for ZA04 Reciprocator and XT09 Horizontal axis</li> <li>- Pendulum operating mode or sequence programs</li> <li>- Max. 250 stored programs possible</li> </ul>
Magic Control CM-10 Plant control	Function
	<ul style="list-style-type: none"> <li>- Master control unit</li> <li>- Communication by CAN bus</li> <li>- 12" Touch Screen</li> <li>- Flash Card for programs and parameters</li> </ul>
OptiControl CM-20 Master control unit	Function
	<ul style="list-style-type: none"> <li>- Master control unit</li> <li>- Communication by CAN bus</li> <li>- 5,7" Touch Screen</li> <li>- Flash Card for parameters</li> </ul>
OptiControl CM03 Integrated master control unit	Function
	<ul style="list-style-type: none"> <li>- Interlocking functions</li> <li>- Gap control</li> <li>- Monitoring the powder level in the powder hopper</li> </ul>
OptiAir CA06 Pneumatic-fluidizing unit	Function
	<ul style="list-style-type: none"> <li>- Automatic prefluidization</li> <li>- Airmover control unit</li> <li>- Fluidization in the powder hopper</li> </ul>



LM02 Level sensor	Function
	<ul style="list-style-type: none"> <li>- Level detection in the powder hopper</li> </ul>

## OptiFlex A2 Control system - possible configurations

### Automatic equipment

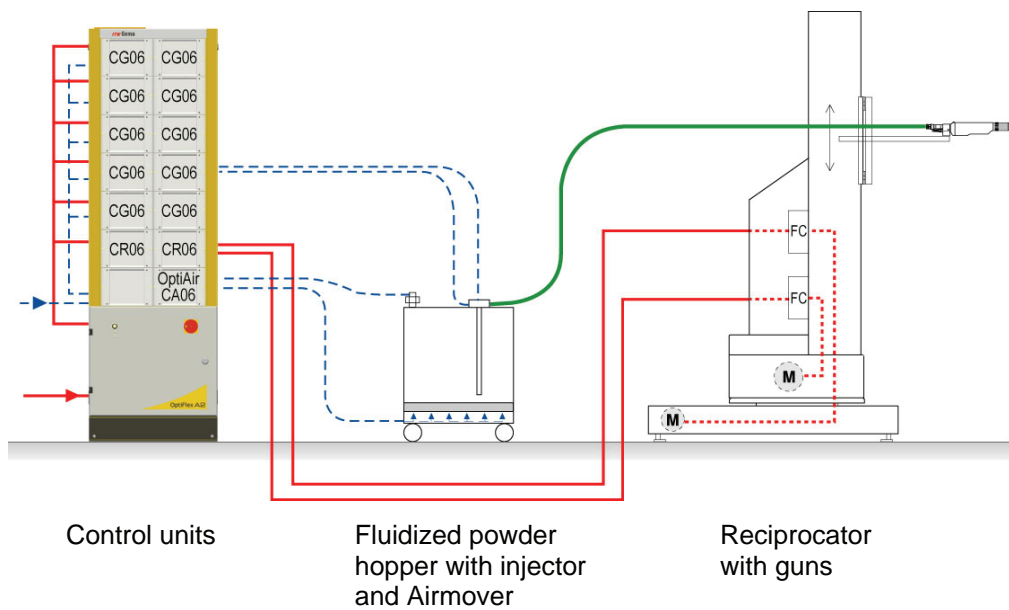

### Automatic equipment with superordinated control unit

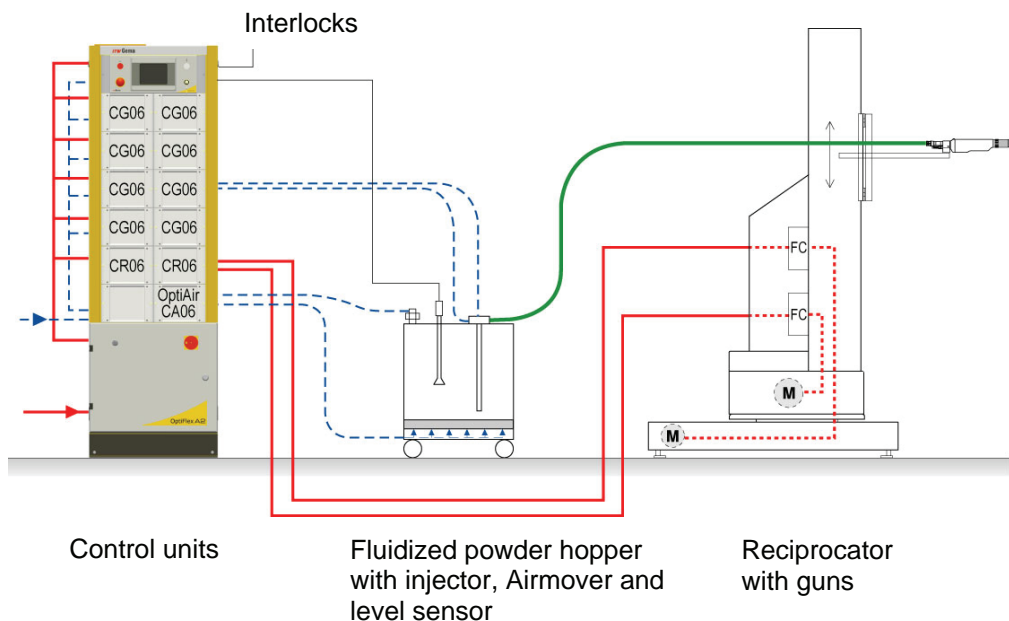



# Technical data

## OptiFlex A2 Control system

### Electrical data

OptiFlex A2 Control system	
Nominal input voltage	100-240 VAC (CG06) 200-240 VAC (CR06)
Operating frequency	50/60 Hz
Input power value	40 VA per gun 1,1 kVA (CR06)
Grounding	Threaded bolt M6
Temperature range (operation)	0-40°C
Protection type (control units)	IP54
Approval	ATEX zone 22

### Pneumatic data

OptiFlex A2 Control system	
Min. input pressure	6 bar / 87 psi
Max. input pressure	10 bar / 145 psi
Max. water vapor content of the compressed air	1,3 g/m <sup>3</sup>
Max. oil vapor content of the compressed air	0,1 mg/m <sup>3</sup>
Total air consumption	without FlowControl - 10,5 m <sup>3</sup> /h by 6,5 bar per gun with FlowControl - 15,5 m <sup>3</sup> /h by 6,5 bar per gun (plus powder hopper air requirement)

### Control cabinet dimensions

OptiFlex A2 Control system	
Width	600 mm
Depth	700 mm
Height	max. 1920 mm

### ICS cabinet dimensions

OptiFlex A2 Control system	
Width	1500 mm
Depth	700 mm
Height	1920 mm



---

**Note:**  
**Further specifications will be found in the corresponding manuals of the components!**

---

# Start-up

---

## Setup and assembly

### Assembly notes

After unpacking and installing the OptiFlex system, the control cabinet is to be fitted to the floor with the supplied steel bolts. The mounting holes are located in the control cabinet base.



The internal connections have already been made at the factory. The control unit connections to the external plant parts must be done at the start-up. The connection possibilities for the individual control units are found in the corresponding operating manuals. **Note:**

**When connecting, pay attention particularly to the length and the radii of the pneumatics hoses!**

---

### Configuration

A maximum of up to 14 control units can be installed. OptiFlex A2 control cabinets can be laterally lined up without gap, and/or be set up at a wall.

Not used openings are covered with blind plates. These are screwed on and can be easily removed, when possible extension of the OptiFlex A2 Control system.

### OptiFlex A2 Control system

Optionally:

- Max. 14 CG06 Gun control units or mixed with:
- CR06 Axes control unit
- CA06 Pneumatic-fluidizing unit

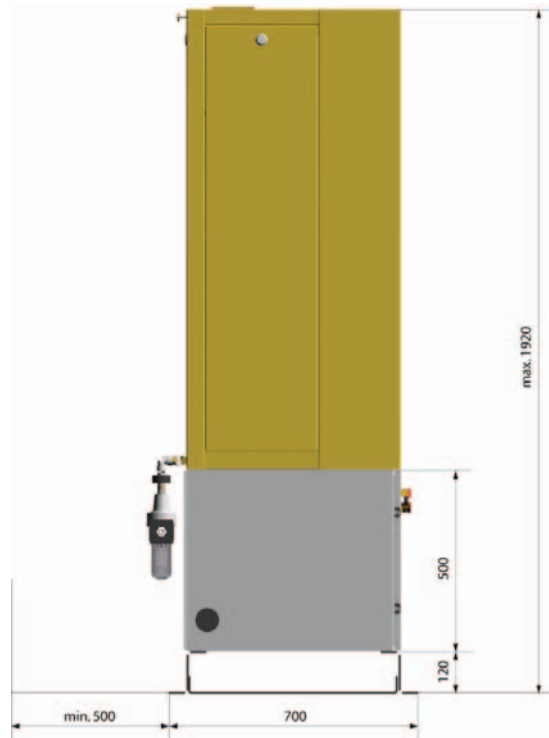

*OptiFlex A2 Control system - assembly*

### OptiFlex A2 Control system with CM-20

OptiControl CM-20 Master control unit

Optionally:

- Max. 14 CG06 Gun control units or mixed with:
- CR06 Axes control unit
- CA06 Pneumatic-fluidizing unit

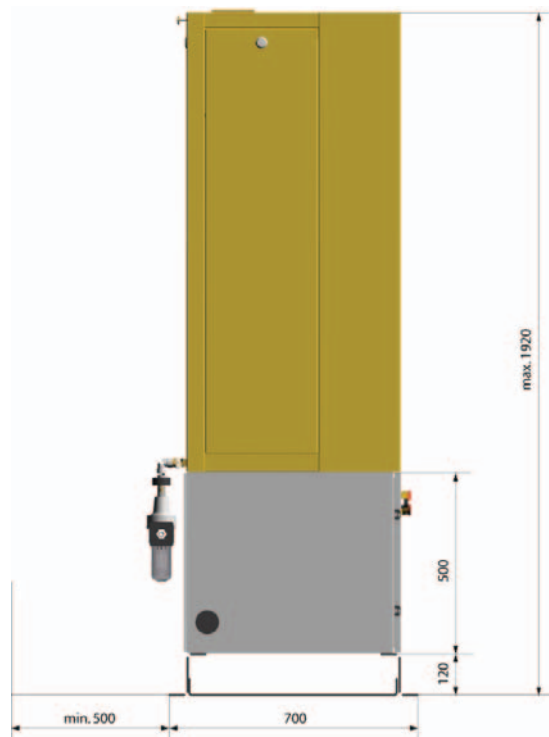

*OptiFlex A2 Control system with CM-20 - assembly*

## OptiFlex A2 Control system with CM-10 Magic Control



*OptiFlex A2 Control system with CM-10 Magic Control*

---

## Procedure for initial start up

### General information

These general information serves to obtain an overview of the possible OptiFlex A2 system combinations.

Detailed information will be found in the corresponding operating manuals!

### Power supply

- The power supply is dependent on the type and the number of control units:  
Stand alone - 1x100-230V / 50/60 Hz  
Full extension - 3x400V+N+PE / 50/60 Hz
- The input power value is system-specific and evident in the provided electrical diagram
- All electrical components are implemented in accordance to IP54 protection type regulations



---

#### Note:

**The OptiFlex A2 powder coating control system may can be switched on only if the booth is in operation!**

**If the booth switches off, the control system must also switch off!**

---

### Compressed air

- The OptiFlex A2 Control system just requires a connection to the main compressed air system
- The compressed air values are evident in the technical data section

### *Air requirement with increased powder output*

The control system offers the possibility to work with increased powder output in sufficiently dimensioned compressed air systems. The pressure regulator is preset by factory to **5.5 bar (80 psi)** with an air flow of **5 m<sup>3</sup>/h (3.25 cfm) per control unit**. If another value is set on the pressure regulator, then the **system parameter 2** on **each OptiStar control unit** needs to be adjusted according to the following instructions:

**Pressure regulator setting - parameter setting:  
CG06 OptiStar Automatic control unit**

⏻ > 5 s

↓

**P2** - +

↓

**0** → **P 55**

↓

**1** → **P 60**

↓

**2** → **P 65**

Conversion bar - psi:

5.5 bar = 80 psi

6.0 bar = 87 psi

6.5 bar = 94 psi

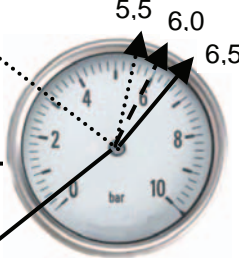

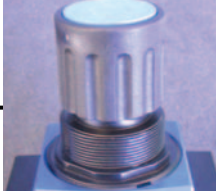



**Note:**

**In order to achieve the largest accuracy, the air pressure is to be set during operation by average compressed air consumption!**



# Schematic diagrams

## OptiFlex A2 Control system - pneumatical diagram

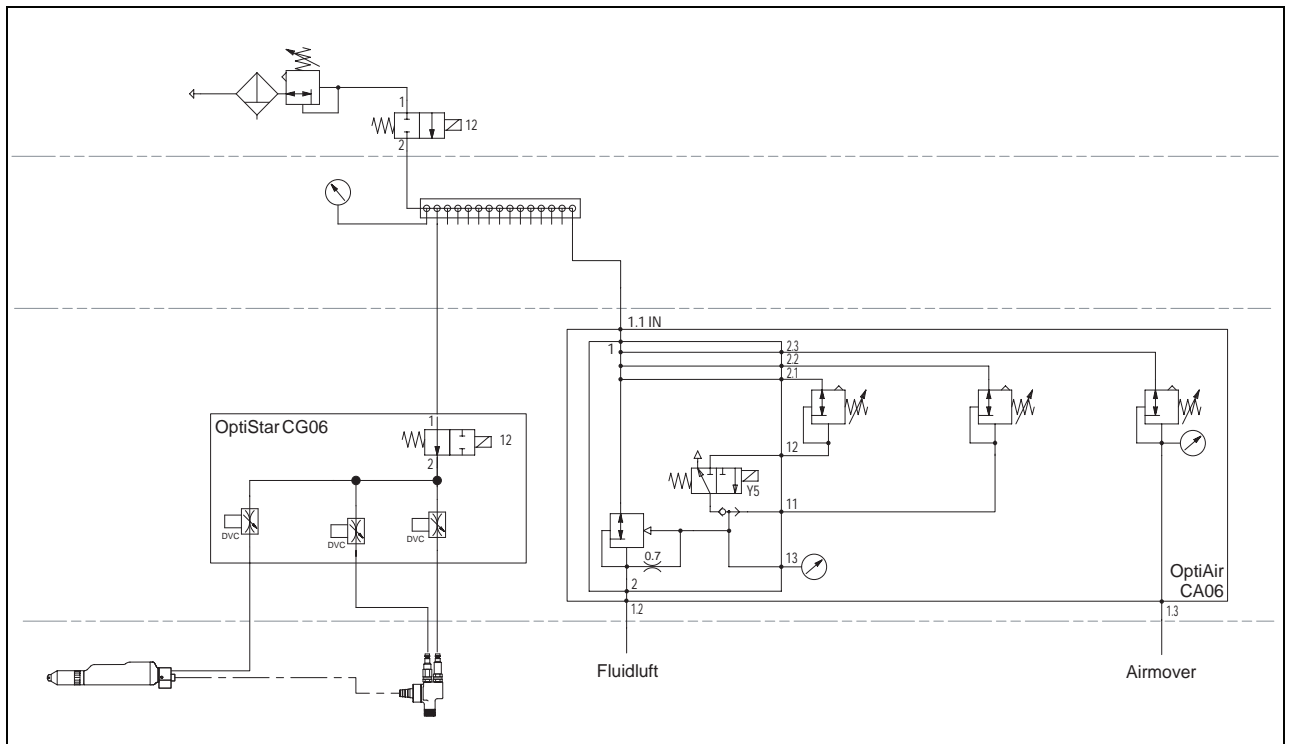

*OptiFlex A2 Control system - pneumatical diagram*



# Spare parts list

---

## Ordering spare parts

When ordering spare parts for powder coating equipment, please indicate the following specifications:

- Type and serial number of your powder coating equipment
- Order number, quantity and description of each spare part

**Example:**

- **Type** OptiFlex A2 Control system,  
**Serial number** 1234 5678
- **Order no.** 203 386, 1 piece, Clamp - Ø 18/15 mm

When ordering cable or hose material, the required length must also be given. The spare part numbers of this yard/meter ware is always marked with an \*.

The wear parts are always marked with a #.

All dimensions of plastic hoses are specified with the external and internal diameter:

**Example:**

Ø 8/6 mm, 8 mm outside diameter (o/d) / 6 mm inside diameter (i/d)



---

**WARNING!**

**Only original ITW-Gema spare parts should be used, because the hazardous location approval will be preserved that way! The use of spare parts from other manufacturers will invalidate the ITW Gema guarantee conditions!**

---

## OptiFlex A2 control cabinet - spare parts list

1	Adaptor nipple - 1/2"a-3/4"a-1/2"i	1002 342
2	Hexagon nut - 3/4"	1002 348
3	T-piece - 1/2"a-1/2"i-1/2"i	223 301
4	Adaptor nipple - 1/4"i-1/2"a	1001 754
5	Push button - 1-10 bar, 1/4"-PG7	233 757
6	Solenoid valve - 1/2", NW 13.5 mm, 230 VAC, incl. valve coil	259 500
	Solenoid valve - 1/2", NW 13.5 mm, 110 VAC, incl. valve coil	1003 234
	Solenoid valve - 1/2", NW 13.5 mm, 24 VDC, incl. valve coil	259 195
7	Valve coil - 230 VAC	1001 158
	Valve coil - 110 VAC	1003 235
8	Double nipple - 1/2"a-1/2"a, divisible	243 582
9	Elbow joint - 1/2"a-1/2"i	223 166
10	Compressed air distributor - 15p, incl. pos. 11	1002 301
11	Plug cap - 3/8"a	266 965
12	Pressure gauge	243 620
13	Connection sleeve - 1/8"i, Ø 8 mm	236 020
14	Plug - Ø 8 mm	238 023
15	Adjusting elbow - Ø 8/8 mm	1001 031
	Pressure regulating unit - complete, pos. 16-24	1003 123
16	Pressure regulator - G1/2"	262 935
17	Double nipple - 1/2"a-1/2"a	243 540
18	Filter separator - G1/2"	262 943
19	Hose connector - Ø 17 mm, 1/2"a	223 069
20	Elbow joint - 1/2"a-1/2"i	223 166
21	Plug cap - 1/4"a	258 695
22	Double nipple - 1/2"a, 150 mm	602 183
23	Elbow joint - 1/2"i, 1/2"i	252 867
24	Double nipple - 1/2"a-1/2"a, divisible	243 582

**Note:**

Further specifications will be found in the corresponding manuals and spare parts list of the components!

## OptiFlex A2 control cabinet - spare parts

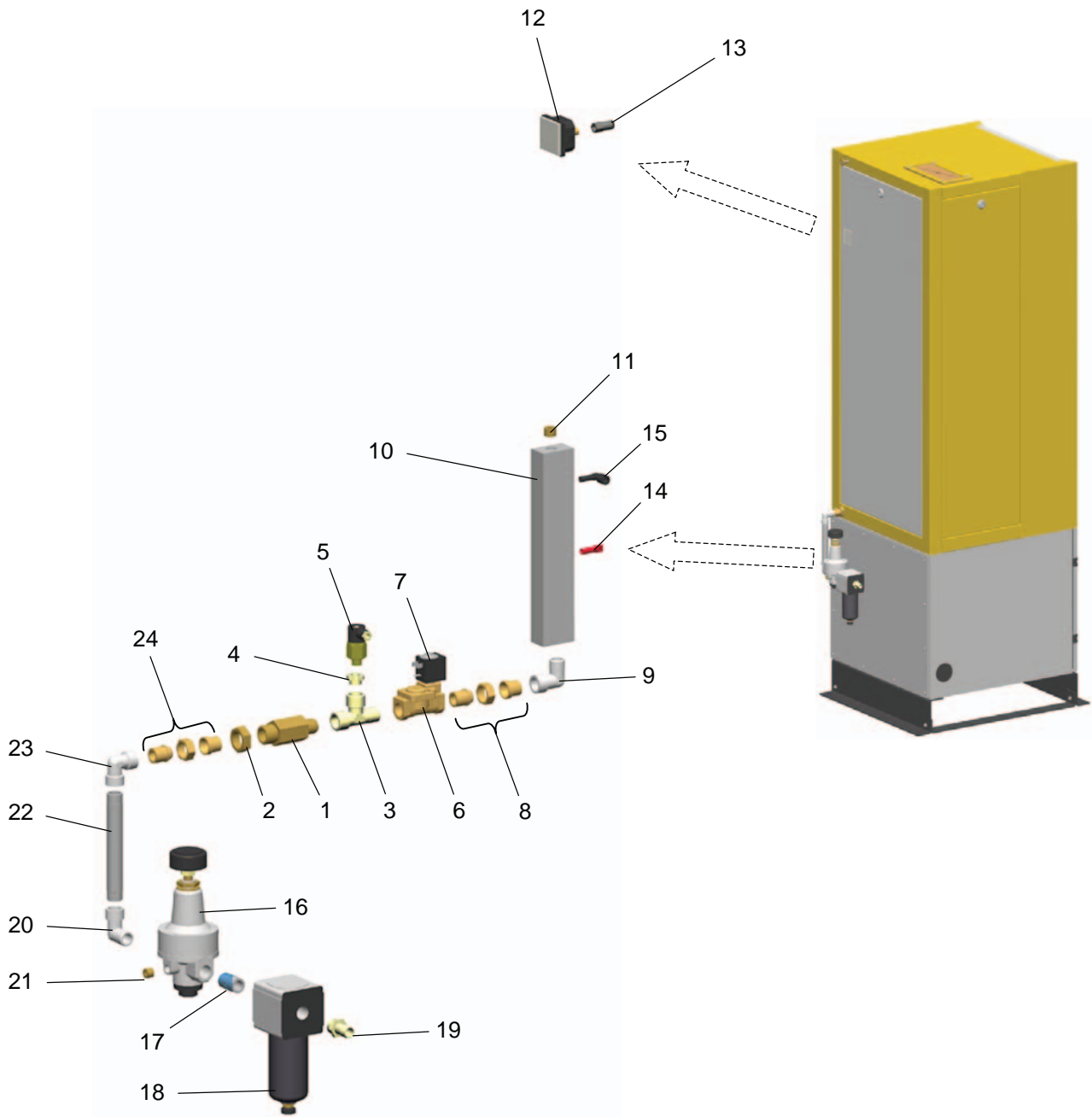

OptiFlex A2 control cabinet - spare parts

---

## OptiFlex A2 - mounting plate

1	AS04 standard mounting plate - complete	1003 160
2	Milled-head screw - M5x25 mm	241 016
3	Main switch - complete	241 210
4	Triple terminal - 2.5 mm <sup>2</sup> , P (grey)	241 636
5	Triple terminal - 2.5 mm <sup>2</sup> , PE (green)	241 652
6	Triple terminal - 2.5 mm <sup>2</sup> , N (blue)	241 644
7	Triple terminal end plate - 2.5 mm	241 660
8	Double conductor end clamp - 10 mm	238 368
9	Triple terminal end plate - 2,5 mm (orange)	1002 618
10	Bridge (1 on 3) - T=5 mm	263 710
11	Contact bridge (1 on 2)	238 392
12	Triple terminal - 2.5 mm <sup>2</sup> , E/N/P, complete	1002 617



---

**Note:**

**The components and the equipment of the OptiFlex A2 mounting plate are plant-specific compiled!**

**Further information about the components will be found in the corresponding wiring diagrams!**

---

# OptiFlex A2 - mounting plate

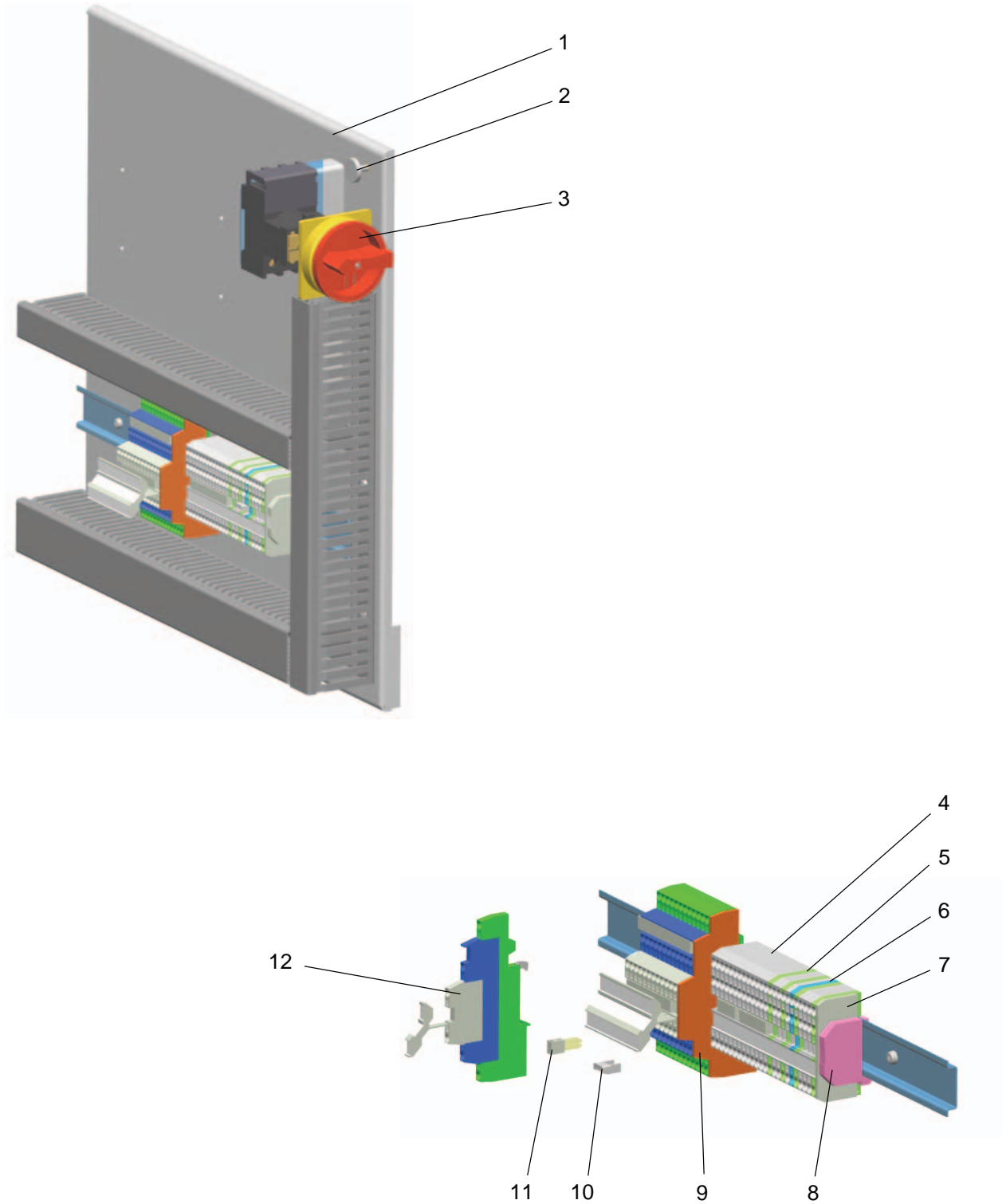

*OptiFlex A2 - mounting plate*