

## EasySystem Stirrer Unit Powder Hopper

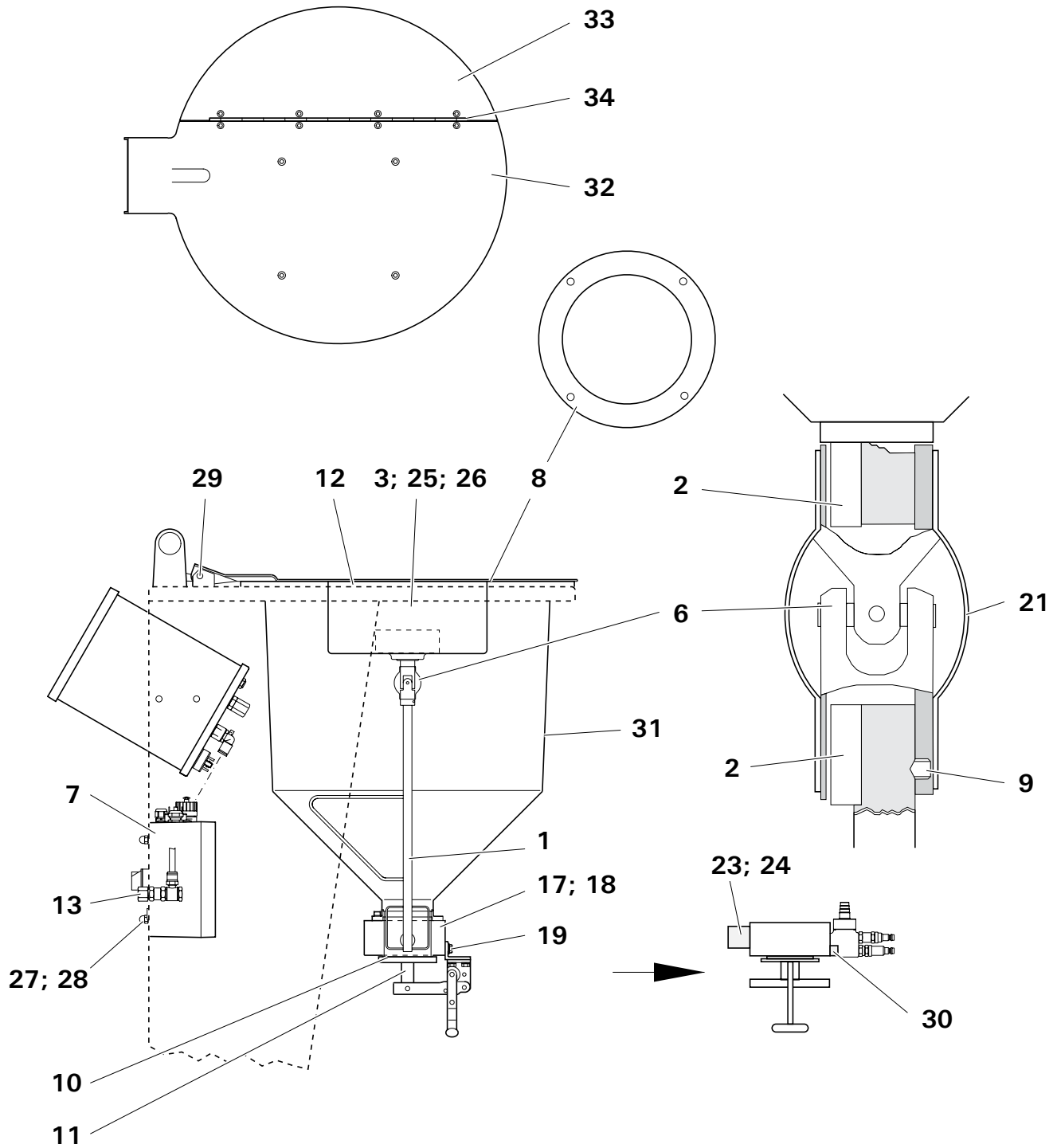



## EasySystem Stirrer Unit Powder Hopper

| Item | Description                             | Part No. | Order No.** |
|------|---|----------|-------------|
| 1    | Stirrer                                 | 366862   | 366862      |
| 2    | Feather key                             | 206075   | 125312      |
| 3    | Stirrer motor with gear (complete)      | 366927   | 125313      |
| 6    | Universal joint                         | 206369   | 206369      |
| 7    | Stirrer control unit CS 01              | 379000   | 379000      |
| 8    | Gasket                                  | 304042   | 125316      |
| 9    | Grub screw M4 x 5 mm                    | 214728   | 214728      |
| 10   | Gasket for discharge flap (ø 75 x 3 mm) | 303240#  | 125317#     |
| 11   | Discharge flap with clamp lever         | 303194   | 112108      |
| 12   | Gasket for powder hopper                | 101630*  | 112109*     |
| 13   | Main air input                          |          |             |
| 17   | Distributor head                        | 379395   | 379395      |
| 18   | O-ring - ø 67 x 2 mm                    | 236403   | 125320      |
| 19   | Shakeproof screw I-6kt M6x 16 mm        | 261823   | 261823      |
| 21   | Protective sleeve                       | 206350   | 125321      |
| 23   | Injector hole plug                      | 380296   | 380296      |
| 24   | O-ring (for Item 23)                    | 231517   | 110306      |
| 25   | Lead-through - PG11 (long)              | 260240   | 260240      |
| 26   | Contact strip - double                  | 208124   | 114788      |
| 27   | Hex screw - M6 x 30 mm                  | 216445   | 216445      |
| 28   | Cap nut - M6 mm                         | 221147   | 221147      |
| 29   | Seeger ring - A-08                      | 226653   | 226653      |
| 30   | Injector holder                         | 380288   | 380288      |
| 31   | Hopper body                             | 366854   | 366854      |
| 32   | Stirrer lid                             | 380628   | 380628      |
| 33   | Filling flap                            | 380636   | 380636      |
| 34   | Hinge                                   | 305472   | 305472      |

# Wear Part

\* Indicate length required

\*\* Please use the "Order No." column when placing orders