

Operating Instructions and Spare parts list

## EasySelect GM01-E Manual Powder Gun

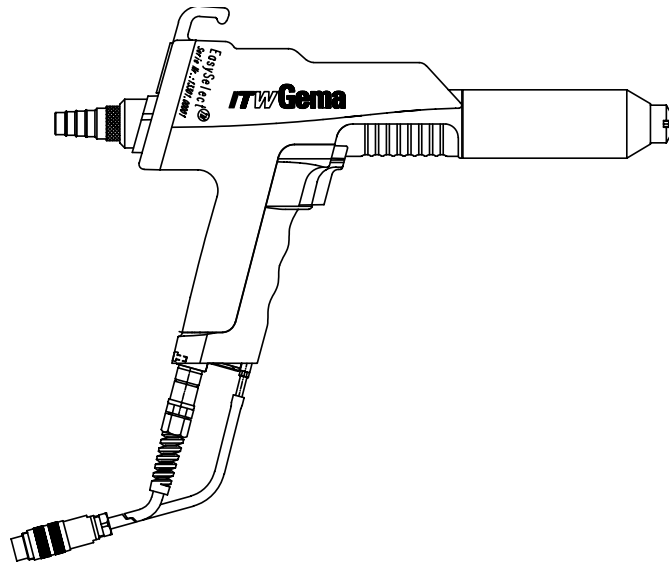



# Table of Contents

## Safety rules

Safety rules for electrostatic powder coating operations

<b>1. EasySelect GM01-E Manual Powder gun</b>	<b>1</b>
1.1 Field of application	1
1.2 Scope of delivery:	1
<b>2. Technical Data for EasySelect GM01-E Manual Powder gun</b>	<b>1</b>
<b>3. EasySelect GM01-E Manual Powder gun</b>	<b>2</b>
3.1. Spray Nozzles	3
3.2 High-voltage Generation	4
3.3 Switching	4
3.4 Powder flow and Rinsing air	5
3.5 Flat jet nozzle with vented central electrode	6
3.6 Round jet nozzle with vented deflector plate and vented central electrode	6
<b>4. Preparation for Start Up</b>	<b>7</b>
4.1 Connecting the EasySelect GM01-E Powder gun	7
4.2 Function check	8
<b>5. Start up</b>	<b>9</b>
5.1 Setting the Powder output and Powder cloud	9
5.1.1 Setting the Total air volume	9
5.1.2 Select the Powder output volume	9
5.1.3 Select Electrode rinsing	9
5.2 Start up - Powder coating	10
5.3 Remote control through the gun	10
5.4 Shutdown	10
5.5 Rinsing the powder hose	10
<b>6. Maintenance schedule</b>	<b>11</b>
6.1 Daily maintenance:	11
6.2 Weekly maintenance:	11
<b>7. Cleaning and Repairs</b>	<b>11</b>
7.1 Cleaning	11
7.2 Dismantling the Gun	12
7.3 Assembling the powder gun	16
7.4 Repairs on the powder gun	16
7.5 Cleaning the Spray Nozzle	16
<b>8. Troubleshooting guide</b>	<b>17</b>
<b>9. Spare parts list</b>	<b>19</b>
9.1 Ordering Spare parts	19
9.2 EasySelect GM01-E Manual gun	20
9.3 Gun Cable - complete	22
9.4 Extension Cable GM01	23
9.5 Nozzle combinations for EasySelect GM01-E	24



## Safety rules

### Safety rules for electrostatic powder coating operations

1. This equipment is dangerous when not operated according to the following standards: EN 50 050 (or VDE 0745, Part 100), EN 50 053, Part 2 (or VDE 0745, Part 102), and specification sheet, ZH 1/443 Electrostatic Powder Coating.
2. All electrostatically conductive parts located within 5 m of the coating area and especially the workpieces *must* be properly grounded.
3. The floor in the coating area *must* be electrostatically conductive.  
Normal concrete is generally conductive
4. The operating personnel *must* wear electrostatically conductive footwear (e.g. leather soles).
5. The operating personnel should hold the gun in the bare hand. If gloves are worn, they *must* be electrostatically conductive.
6. Connect the grounding cable (yellow/green) supplied to the grounding terminal on the control module. The grounding cable *must* have a good metal to metal connection with the coating booth, recovery unit, and the workpiece conveyor system, especially with the workpiece suspension.
7. The electrical and the powder feed lines to the guns must be laid out so that they are protected from possible mechanical damage.
8. The powder coating equipment should only be switched on after the booth is in operation. If the booth breaks down then the powder coating equipment *must* also switch off.
9. Check the grounding of all electrostatic conductive parts at least once a week.
10. When cleaning the gun or changing nozzles the control module *must* be switched off



## 1. EasySelect GM01-E Manual Powder gun

The very light EasySelect GM01-E Manual Powder gun with an integrated High-voltage cascade has very good penetration and because of the patented, vented electrode a high, and constant transfer efficiency. The gun can be easily dismantled, making it maintenance and repair-friendly.

### 1.1 Field of application

The OptiGun AE Automatic Powder Gun is built exclusively for the electrostatic coating with enamel powders. Any other use beyond this is not intended. The manufacturer is not responsible for any damage resulting from this; the risk for this is carried by the user alone.

### 1.2 Scope of delivery:

- EasySelect GM01-E Manual Powder gun
- Threaded sleeve - PU04-F-NF
- Gun cable - L = 6 m
- Rinsing air hose - L = 6 m
- Flat jet nozzle - NF05-E - complete
- Gun cleaning brush - D 12 mm
- Spare parts set

## 2. Technical Data for EasySelect GM01-E Manual Powder gun

Nominal input voltage:	0–10 V DC (depending on mode and operation)
Nominal output voltage:	80 kV
Polarity:	Negative (Option - Positive)
Max. Output current:	150 $\mu$ A
High-voltage display:	2 color Light emitting diode - (LED) (Different application settings when triggering the gun)
Flash protection:	IP54
Approval:	Eex 2mJ PTB No. Ex01.D.9102

*Connection: The EasySelect GM01-E must only be connected to the EasyTronic CG01 / OptiTronic CG02 / 03 Control unit.*

**3. EasySelect GM01-E Manual Powder gun**

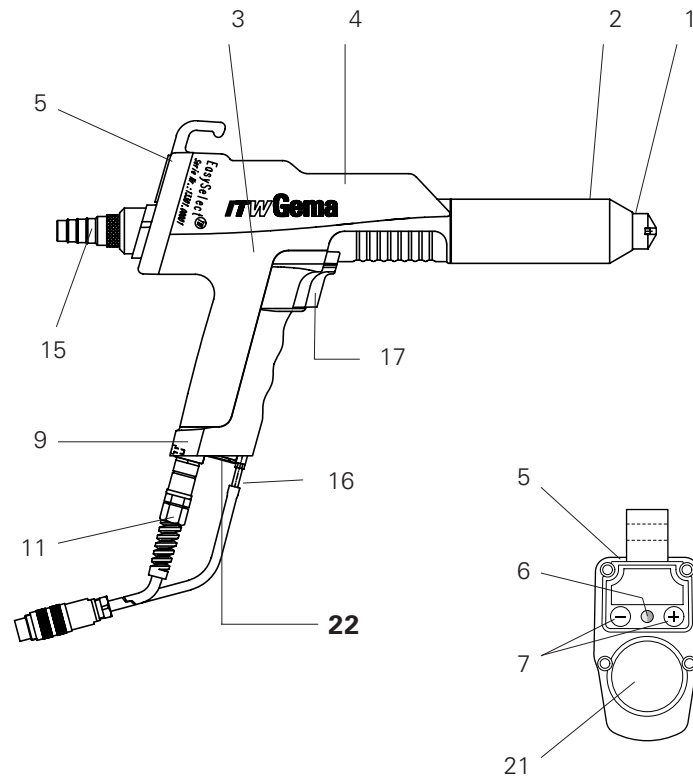

- |                       |                                |
|-----------------------|--------------------------------|
| 1 Spray Nozzle system | 9 Grip                         |
| 2 Threaded sleeve     | 11 Powder gun cable connection |
| 3 Shaft               | 15 Powder hose connection      |
| 4 H-V cascade         | 16 Rinsing air hose connection |
| 5 End plate with hook | 17 Trigger                     |
| 6 LED                 | 21 Powder hose connection      |
| 7 Remote control keys | 22 Sealing plug                |

Figure 1



### 3.1. Spray Nozzles

The EasySelect GM01-E Manual Powder gun can be equipped with the following spray nozzles. For more information see also „Nozzle combinations for EasySelect-E“ in the Spare Parts List

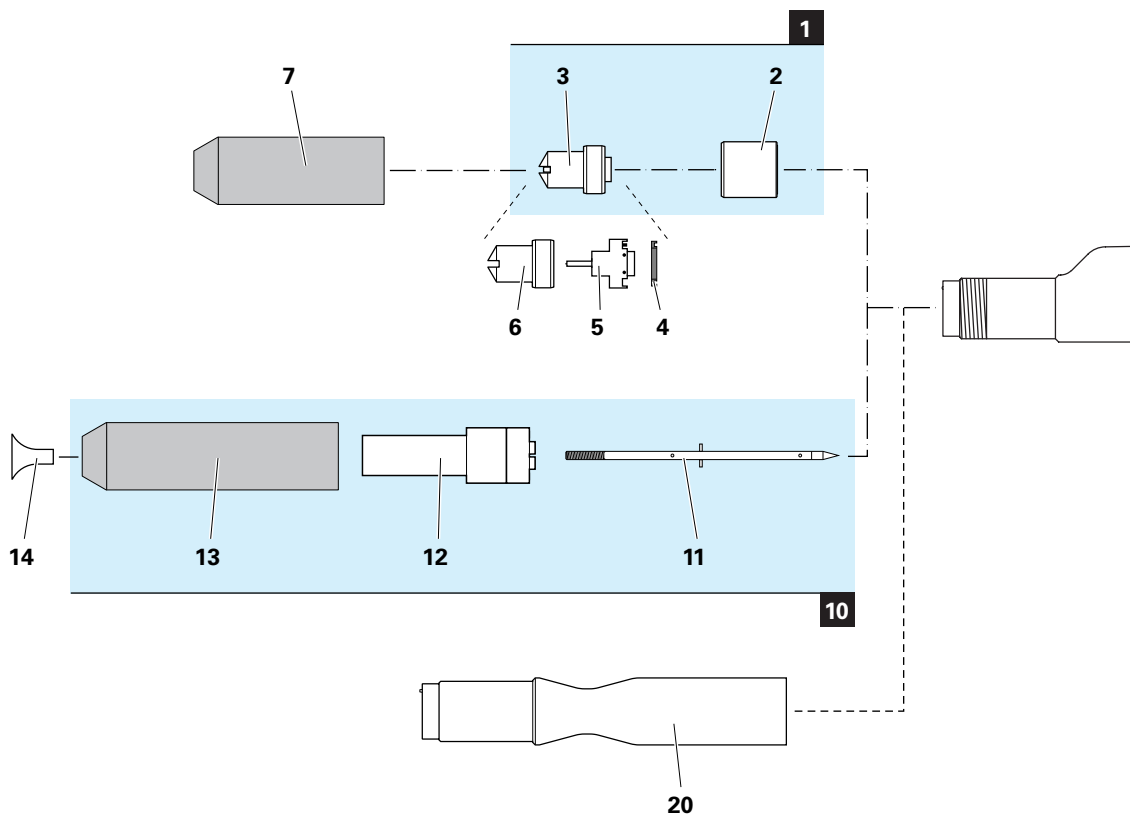

Figure 2

### 3.2 High-voltage Generation

The control unit supplies DC voltage to the gun. This is fed through the powder gun cable (11) to the high-voltage generation section (4). The integrated electronics (c) in the gun generates an alternating current from the direct current. This alternating current is stepped up in the multiplier (d) to the rectified high-voltage required for the application. The High-voltage is now fed to the electrode (e) in the spray nozzle (compare Figs 5 and 6).

The coating mode chosen - Flat parts, Complicated parts, Over-spraying - is indicated through a red, and a green LED (Light emitting diode).

### 3.3 Switching

In addition to the low voltage a switching current is fed into the gun through the gun cable.

If the gun trigger (17) is pulled, a reed switch closes the current circuit. The control unit switches the modulated low voltage, powder conveying, and the rinsing air on.

The reed switch complies with the safety regulations of all recognized standards.

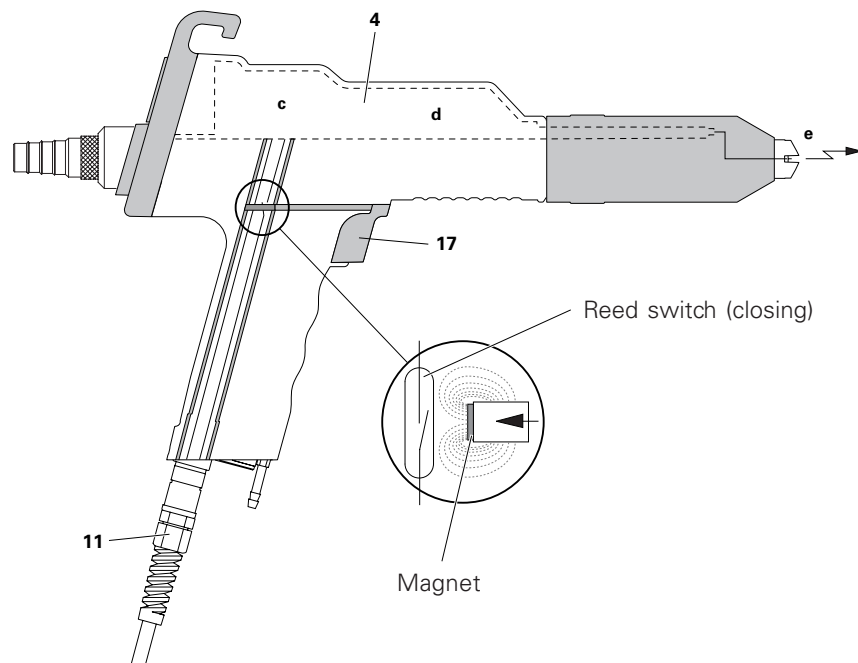

Figure 3

### 3.4 Powder flow and Rinsing air

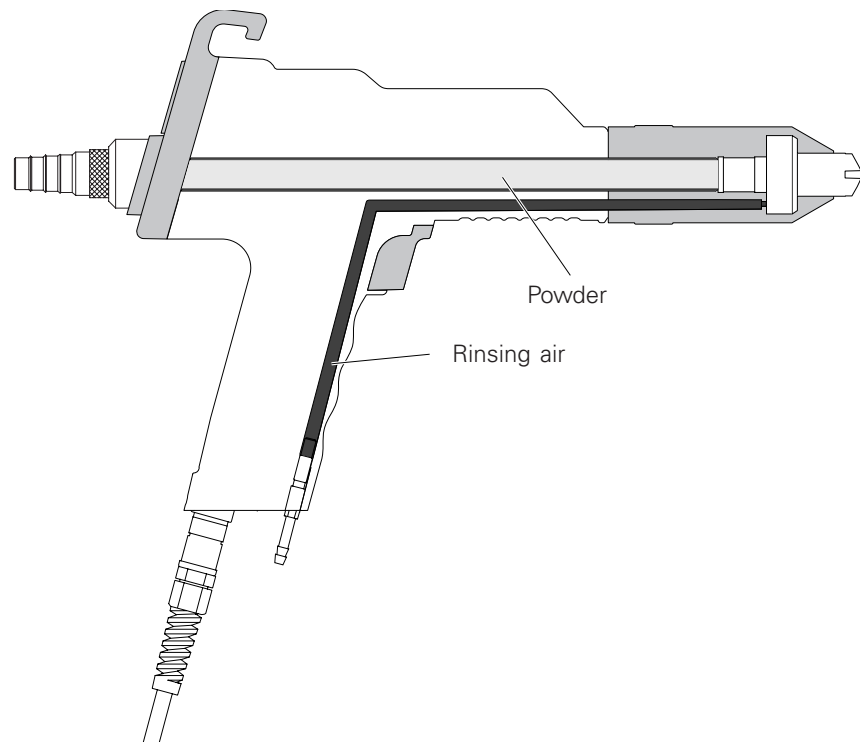

Figure 4

The rinsing air is connected to the corresponding connection on the rear of the control unit when using vented spray nozzles (see Control unit Operating Instructions).

The function of the spray nozzles are described in the corresponding section (see page 6).

### 3.5 Flat jet nozzle with vented central electrode

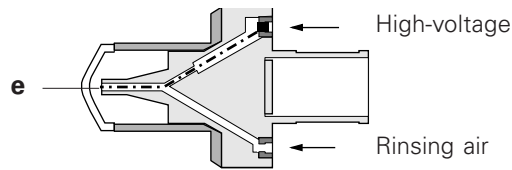

Figure 5

The vented Flat jet nozzle serves to spray, and charge the powder. The powder cloud acquires an oval spray profile from the slotted opening. The powder is charged by means of a central electrode. The High-voltage, generated in the powder gun is fed through the black contact ring of the nozzle holder to the central electrode.

To avoid powder sintering on the electrode, it is rinsed with compressed air during spraying. The rinsing air is fed through the small hole in the black contact of the nozzle holder in the electrode holder.

The adjustment of the rinsing air on the control unit is explained in the "Operating Instructions of the Control unit").

### 3.6 Round jet nozzle with vented deflector plate and vented central electrode

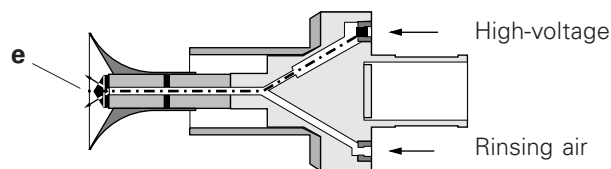

Figure 6

In order to give the powder stream leaving the powder gun the shape of a powder cloud, a deflector plate is used. The powder is charged by means of a central electrode. High-voltage is generated in the powder gun, and is fed through the black contact ring of the nozzle holder to the central electrode.

Because powder sinters on the back of the deflector plate it must be rinsed with air. Rinsing air is fed through the small hole in the black contact ring of the nozzle holder in the electrode holder and so deflected that it flows over the back surface of the deflector plate. The strength of the rinsing air is dependent on the powder, and its sintering properties.

Regulation of the rinsing air on the control unit is explained in the "Operating Instructions of the Control unit").

## 4. Preparation for Start Up

### 4.1 Connecting the EasySelect GM01-E Powder gun

1. Connect the gun plug to the control unit (see Control unit Operating Instructions)
2. Connect the rinsing air hose from the control unit to the gun
3. Connect the powder hose from the powder gun to the injector

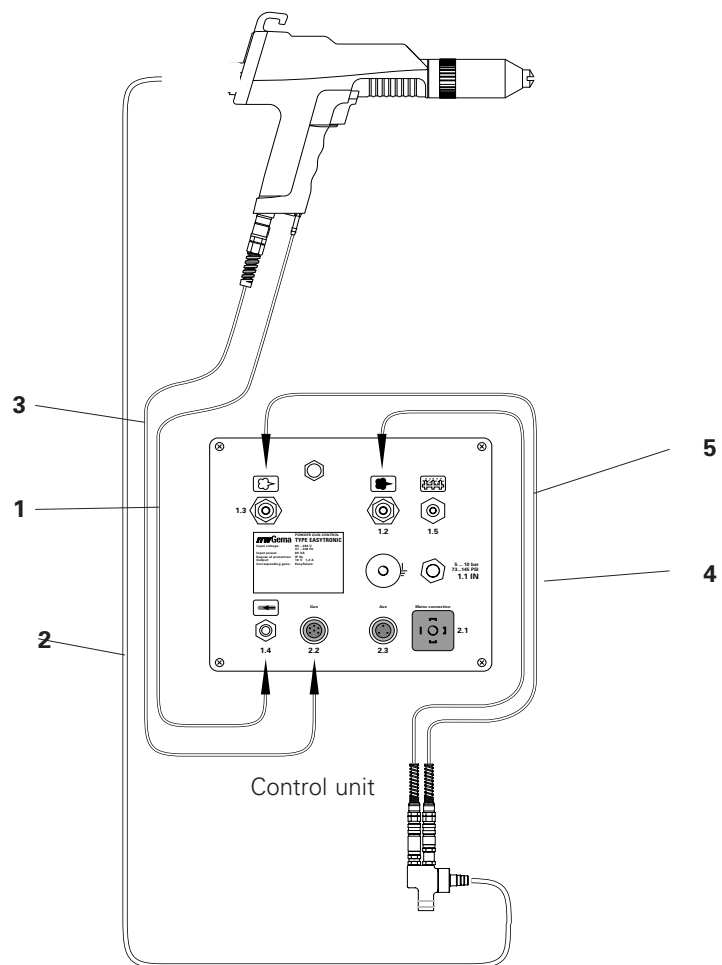

- |                    |                          |
|--------------------|--------------------------|
| 1 Rinsing air hose | 4 Supplementary air hose |
| 2 Powder hose      | 5 Conveying air hose     |
| 3 Powder gun cable |                          |

Figure 7

## 4.2 Function check

If a fault is present, see "Troubleshooting Guide", page 17.  
(also consult the Control unit Operating Instructions)

1. Switch on the control unit
2. Press the desired application key on the control unit.  
(See also the Control unit Operating Instructions).
3. Pick the gun up and point it at a **grounded** object, at a distance of approx. 20 cm.
4. Press the gun trigger
  - The LED No. 8 for the High-voltage display illuminates on the control unit. High-voltage is present in the EasySelect GM01-E Manual Powder gun.
  - The High-voltage can be set with the corresponding keys (See also the Control unit Operating Instructions).
5. Press the gun trigger and select the powder output and total air volume.
  - The display indicates the powder output and total air volume.
6. Press the corresponding key for the rinsing air on the control unit (according to the nozzle used).

When all the checks are positive, the gun is ready for operation.  
When a malfunction occurs the cause of fault can be determined with the aid of the "Troubleshooting Guide" page 17.

## 5. Start up

### 5.1 Setting the Powder output and Powder cloud

The powder output is dependent on the powder, and the total air volume.

#### 5.1.1 Setting the Total air volume

1. Switch on the control unit
2. Set the Total air volume

The total air volume is dependent on the length of the powder hose, the number of turns of the hose, the hose diameter, the conveying air pressure, and the supplementary air. The "Functioning of the injectors and the influence of supplementary air" is described in the EasyFlow Operating Instructions.

The set value for the total air volume can be left as it is, as long as the same powder hose is used. If the hose length and/or the hose diameter are changed, then the total air volume must be reset.

#### 5.1.2 Select the Powder output volume

3. Select the powder output volume in relation to the desired coating thickness.

The selection is done with the aid the keys **+** and **-**, either on the control unit or on the remote control keys on the back of the gun.

Before starting, it is recommended to use a standard setting of 60%. The total air volume is held constant automatically.

4. Check the fluidizing of the powder
5. Point the gun into the booth and press the gun trigger
6. Select the correct electrode rinsing

When using Flat jet nozzles

- Press the key with the corresponding symbol . The LED of the corresponding key illuminates.

When using Round jet nozzles with vented deflector plate

- Press the key with the corresponding symbol . The LED of the corresponding key illuminates.

7. Adjust the powder cloud on a test piece

When using Flat jet nozzles

- Loosen the threaded sleeve by turning it approx. 45°, so that the Flat jet nozzle (or extension) can barely be turned
- Turn the Flat jet nozzle in the desired axial direction
- Retighten the threaded sleeve

When using Round jet nozzles with vented deflector plate

- Change the deflector plate (ø 16, 24, and 32 mm) are supplied with the powder gun

## 5.2 Start up - Powder coating



**Make sure that all electrically conductive parts within a 5 m radius around powder coating stand are grounded!**

1. Switch on the control unit.
2. Pick up the gun and hold it in the powder coating booth, however, do not point it at the object to be coated.
3. Choose the application setting  
Press the corresponding application key  on the control unit. The LED of the corresponding key illuminates.
4. Press the gun trigger
5. Set the High-voltage:  
High-voltage control on the LED 8 on the control unit
6. Wait until the first powder surge has left the gun.
7. The workpieces can now be coated.

## 5.3 Remote control through the gun

The different functions can be remotely controlled with aid of the keys **+** and **-** on the back of the gun:

1. Select the application settings  
Press the Keys  on the powder gun **simultaneously**.  
*Check by observing the LED display on the powder gun:*  
RED = Flat parts  
GREEN = Complicated parts  
RED/GREEN (alternating) = Spraying over
2. Change the powder output  
Press the Key **+** or **-** on the powder gun. The powder output is increased or decreased correspondingly.

## 5.4 Shutdown

1. Release the gun trigger.
2. Switch off the control unit  
*The settings for High-voltage, rinsing air and powder output remain in the memory.*
3. For work interruptions such as lunch breaks, overnight, etc., disconnect the compressed air supply.

## 5.5 Rinsing the powder hose

Before long idle periods residual powder must be removed from the powder hose as follows:

1. Remove the powder hose from the hose connection on the injector (see "EasyFlow Injector" Operating Instructions)
2. Point the manual gun in to the booth

(cont.)



3. Blow the powder hose through with compressed air  
The powder hoses can be cleaned well when a foam rubber cube, from the packing material, is blown through with compressed air. Our specially designed compressed air gun (**Order No. 346 055**) should be used for this purpose. Foam cubes can be ordered in sheets of 100 pieces (**Order No. 241 717**).
4. Reconnect the powder hose to the hose connection on the injector.

## 6. Maintenance schedule

Regular, and conscientious maintenance will increase the operating life of the unit and ensure a constant coating quality longer!

### 6.1 Daily maintenance:

- 1a Clean the gun, see below

### 6.2 Weekly maintenance:

- 1b Clean the injector, and gun, and if present the powder hopper. (Only fill the powder hopper shortly before starting the coating operation).
- 2b Check the grounding connections of the control unit with the powder coating booth, the workpiece hangers or the chain conveyor .

## 7. Cleaning and Repairs

### 7.1 Cleaning

Frequent cleaning the powder gun serves to ensure the quality of the coating.



**Switch off the control unit, and disconnect the gun plug (3 - Fig. 7) before cleaning the powder gun.  
The compressed air used for cleaning must be free from oil and water.**

#### Daily:

1. Blow off the outside of the gun and wipe clean etc.

#### Weekly:

2. Remove the powder hose from the connection.
3. Remove the spray nozzle from the powder gun and clean.
4. Blow the gun through with compressed air, from the connection in the direction of flow.
5. Clean the gun tube (Fig. 11) with the brush supplied.
6. Blow the gun through with compressed air again.
7. Reassemble the gun and connect.
8. Blow the powder hose through and clean.

## 7.2 Dismantling the Gun



The gun should only be dismantled when this is made necessary by a defect or contamination.

The gun should be dismantled only so much to make the desired parts accessible.

The control unit must be switched off and the gun plug disconnected before cleaning the powder gun.

The High-voltage cascade (4) must not be dismantled, as it is assembled with a special process. Should it be defect or the shaft is broken, then the complete shaft (3) must be sent to an authorized ITW Gema Service Centre.

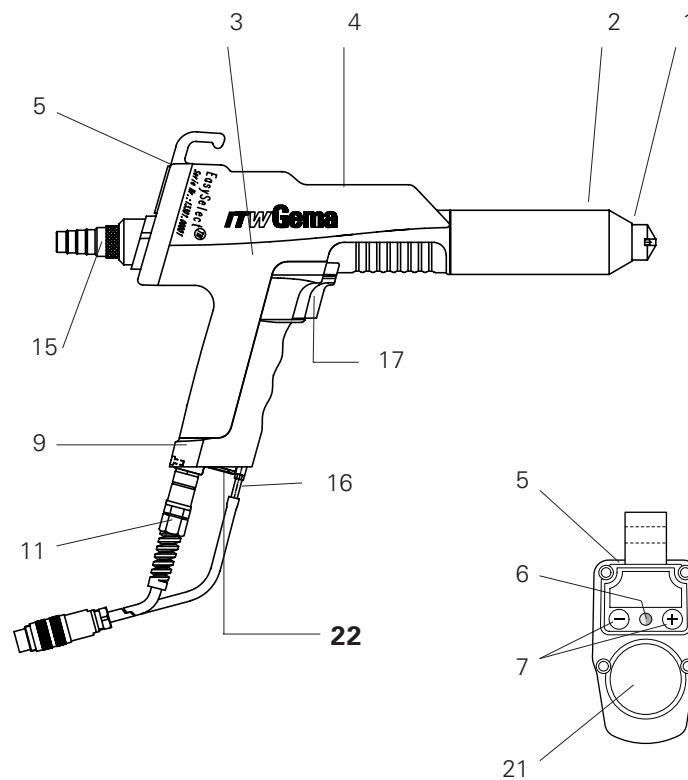

Figure 8

**7.2 Dismantling the gun (cont.)**



Figure 9

7.2 Dismantling the gun (cont.):



Figure 10

**7.2 Dismantling the gun (cont.):**



Figure 11

### 7.3 Assembling the powder gun

- The assembly of the gun is carried out in the reverse order to that illustrated above.
- It is to be noted, thereby, that the powder tube is to be pressed in up to the stop.

### 7.4 Repairs on the powder gun

Except for the replacement of possibly defect parts, there are hardly any repairs to be made. Replacement of the cascade, and the repair of the powder gun cable connection (**11** - Fig. 8) is **only** permitted by an *authorized* ITW Gema Repair Centre. Contact your ITW Gema representative.

### 7.5 Cleaning the Spray Nozzle

#### Daily or after every shift:

- Clean the spray nozzle externally with compressed air. Solvents or other liquids can also be used for cleaning the spray nozzle.



**Only use a cloth *dipped* in solvent for cleaning, *never* immerse the parts in solvents!**

- Check the seating of the spray nozzle: Make sure that the threaded sleeve is always well tightened. If the spray nozzle is only loosely fitted, the danger exists that the High-voltage from the powder gun can flash over, which will inevitably lead to damage to the powder gun.

#### Weekly:

- Remove the spray nozzle and clean inside with compressed air: If sintering has occurred, then this must be removed.

#### Monthly:

- Check the spray nozzle for wear:

Flat jet nozzles must be replaced when :

- the spray pattern is no longer a regular oval shape.
- there are deep grooves in the nozzle slot, or the wall thickness is no longer recognizable.
- the wedge of the electrode holder worn away.

Nozzles with a deflector plate:

- when the wedge of the electrode holder is worn away, the electrode holder is to be replaced.

## 8. Troubleshooting guide

The Diagnostic LEDs 1 - 7 on the control unit illuminate green when switching on, and LED 8 remains dark. It illuminates red, only when the powder gun trigger is pulled.

Fault	Causes	Remedies
LED 5 illuminates red	<ul style="list-style-type: none"> <li>– The gun is not connected</li> <li>– Gun plug, gun cable or gun cable connection defect</li> <li>– Remote control on the gun defect</li> </ul>	<p>Connect the gun</p> <p>Replace corresponding part or send in for repair</p> <p>Replace remote control (gun cover)</p>
LED 6 illuminates red	Solenoid valve for rinsing air of the Flat jet nozzle defect	Replace solenoid valve spool
LED 7 illuminates red	Solenoid valve for rinsing air of the Round jet nozzle defect	Replace solenoid valve spool
LED 8 remains dark, in spite of the gun trigger being pulled and the LED 5 illuminates green.	Gun plug, gun cable or gun cable connection defect	Replace corresponding part or send in for repair
The gun LED remains dark, in spite of the gun trigger being pulled and the LED 8 illuminates red.	<ul style="list-style-type: none"> <li>– Gun plug, gun cable or gun cable connection defect</li> <li>– Remote control on the gun defect</li> </ul>	<p>Replace corresponding part or send in for repair</p> <p>Replace remote control (gun cover)</p>
Powder does not adhere to the workpiece, in spite of the gun trigger being pulled and and the gun sprays powder, the gun LED, and the LED 8 illuminate.	<ul style="list-style-type: none"> <li>– High-voltage and current deactivated</li> <li>– High-voltage cascade defect</li> <li>– the workpieces are poorly grounded</li> </ul>	<p>Press the selection button (application button)</p> <p>Send the gun in for repair</p> <p>Check the grounding, see also "Directions of Use"</p>
		(cont.)

## 8. Troubleshooting guide (cont.)

Fault	Causes	Remedies
<p>The gun does not spray powder, in spite of the control unit being switched on, and the trigger is pressed.</p>	<p>No compressed air present</p> <ul style="list-style-type: none"> <li>– Conveying vacuum to low</li> <li>– Injector, check valve or nozzle on the injector, powder hose or gun clogged</li> <li>– Sleeve in the injector worn or not present</li> <li>– Sleeve in the injector clogged</li> <li>– Fluidizing does not function</li> </ul> <p>No conveying air:</p> <ul style="list-style-type: none"> <li>– Reduction valve defect</li> <li>– Solenoid valve defect</li> <li>– Electronic card defect</li> </ul>	<p>Connect the equipment to the compressed air</p> <p>Increase the powder output and/or the total air volume on the control unit</p> <p>Clean the corresponding part</p> <p>Replace or insert</p> <p>Replace</p> <p>Check the fluidizing</p> <p>Replace</p> <p>Replace</p> <p>Send in for possible repair</p>



## 9. Spare parts list

### 9.1 Ordering Spare parts

When ordering spare parts for powder coating equipment, please indicate the following specifications:

1. Type, and serial number of your powder coating equipment
2. Order number, quantity, and description of *each* spare part

**Example:**

1. **Type** EasySelect GM01-E      **Serial no:** xxxx xxxx
2. **Order no:** 232 670,      5 pieces,      O-ring -  $\varnothing$  13.1 x 1.6 mm

When ordering cable or hose material the lengths required must also be given.

The spare part numbers of yard/metre ware always begins with 1.. ... and are always marked with an \* in the spare parts list.

Wear parts are always marked with a #.

All dimensions of plastic powder hoses are quoted as external (o/d), and internal (i/d) diameters :

e.g.  $\varnothing$  8 / 6 mm = 8 mm outside diameter (o/d) / 6 mm inside diameter (i/d).

## 9.2 EasySelect GM01-E Manual gun

### Remarks:

1. Only parts those which the customer can replace himself, without problems, are given in the Spare parts list.
2. Should a part of the shaft (**3**) be broken or the High-voltage cascade in the shaft is defect, then the complete shaft must be sent in for checking and repair. The High-voltage cascade is fitted in a special process and should, therefore, never be dismantled by the customer.
3. If the powder gun cable (**11**) is defect, then the complete cable is to be sent in for repair.

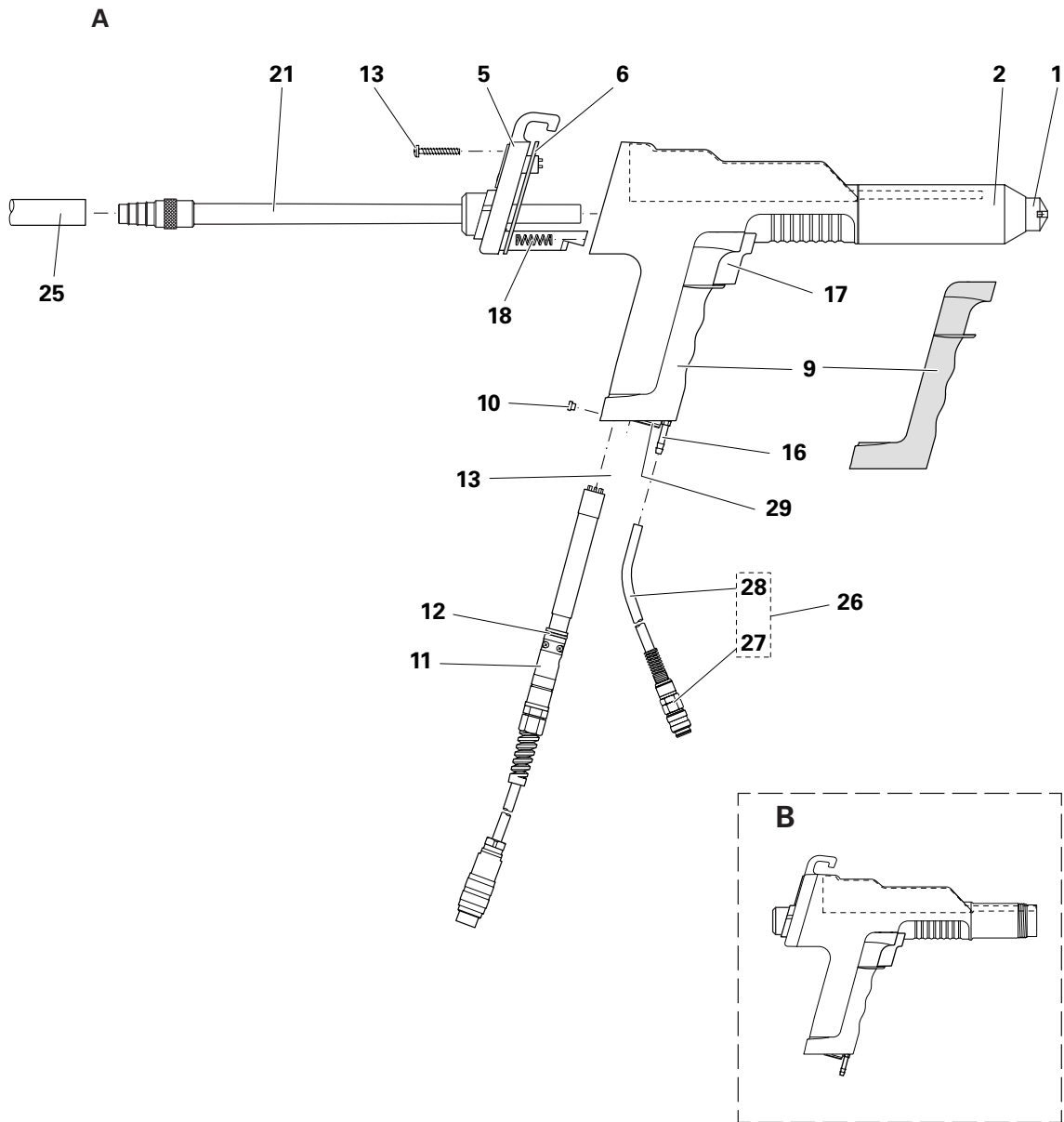

Figure 12

## 9.2 EasySelect GM01-E Manual gun

<b>A</b>	<b>EasySelect GM01-E</b> Manual Powder gun - complete Negative polarity, incl.: Powder gun cable - 6 m, Rinsing air hose - 6 m, Flat jet nozzle, Brush, and parts set, without powder hose	406066
<b>B</b>	<b>EasySelect GM01-E</b> Manual Powder gun, incl. Cascade	
	Polarity – (negative)	406074
	Polarity + (positive)	406082
1	Nozzle - see next page	
2	Threaded sleeve - see next page	
5	End plate with hook	406120
6	End plate seal (for Item <b>5</b> )	377848
9	Grounding plate	406104
10	Cylinder screw - M 3 x 6 mm	262021
11	Powder gun cable - complete - 6 m	378232
	Powder gun cable - complete - 12 m	378240
12	O-Ring (for Item <b>11</b> )	261416
13	"PT" Special screw	261785
16	Rinsing air connection	378003
17	Trigger complete incl. Item 18	379093
18	Return spring	261572
21	Powder tube complete	406112
25	Powder hose - 1004 - ø 16 / 11 mm (standard)	103128##*
	Powder hose - 1005 - ø 20 / 12 mm	100080##*
26	Rinsing air hose - 6 m - complete (incl. Items <b>27</b> and <b>28</b> )	339954
	Rinsing air hose - 12 m - complete (incl. Items <b>27</b> and <b>28</b> )	380261
27	Quick-release connection - ø 6 / 4 mm	200840
28	Rinsing air hose - ø 6 / 4 mm	100854*
29	Sealing plug	406163
	Brush for powder tube (not shown)	389765
	Parts Set consisting of:	406180
	- O Ring - D 12 x 1.5 mm (for Item <b>11</b> )	
	- O Ring - D 13.1 x 1.6 mm	
	- Cylinder screw (Item <b>10</b> )	
	- Cable clamp	

\* Please indicate length required

# Wear parts

## 9.3 Gun Cable - complete

Gun cable complete - 11 m	382876
Gun cable complete - 15 m	382884
Gun cable complete - 20 m	382892
8 Over tube	360317
11 C/sk screw - M2 x 4 mm	257958
12 Cyl. screw - M5 x 6 mm	263907
13 O-Ring - D10.82 x 1.78 mm	232556
14 O-Ring - D07.65 x 1.78 mm	232564
15 O-Ring - D08.10 x 1.60 mm	263818
21 Gland PG07 with kink protection	208426
22 Cable - 3 x 0,75mm <sup>2</sup> - screened	104892*
23 Cable plug - 6-pin	261475

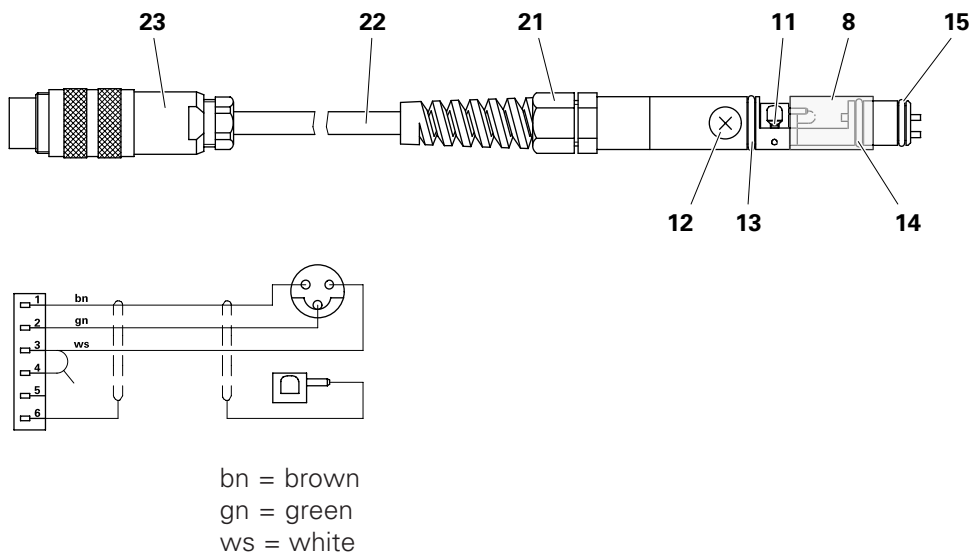
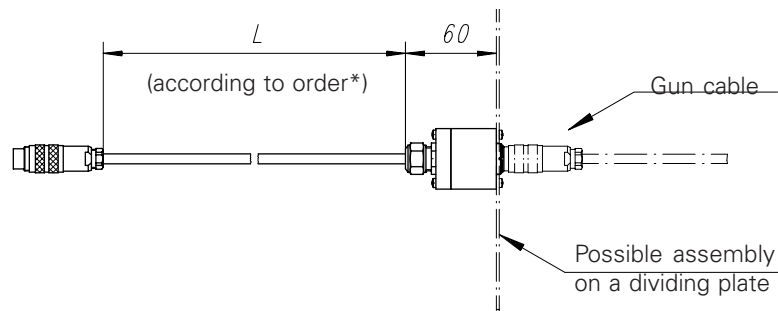

Figure 14

**9.4 Extension Cable GM01**

Extension cable

On request



\* Maximum cable length: 50 m (Extension cable and Gun cable together)

\*Please indicate length required

Figure 15

## 9.5 Nozzle combinations for EasySelect GM01-E

1	Flat Jet Nozzle - NF05-E - complete	405744#
2	Adapter - complete	406023#
3	FSD-Nozzle set (without Item 5.1)	404225#
4	Contact ring	318760#
5	Electrode holder - complete - Tefzel	404209#
5.1	Electrode holder - complete - Teflon	406058#
6	Flat Jet Nozzle	404128#
7	Threaded sleeve - PU04-E-NF	405728
10	Round Jet Nozzle NS03-E komplett	405752#
11	Deflector plate rod - complete	405582#
12	Nozzle - complete	405949#
13	Threaded sleeve - PU04-E-NS	405736
14	Deflector plate - ø 15 mm	400262#
14.1	Deflector plate - ø 24 mm	400181#
14.2	Deflector plate - ø 28 mm	400254#
14.3	Deflector plate - ø 32 mm	400238#
14.4	Deflector plate - ø 50 mm	400246#
20	Extension - 150 mm	405922#
20.1	Extension - 300 mm	405930#

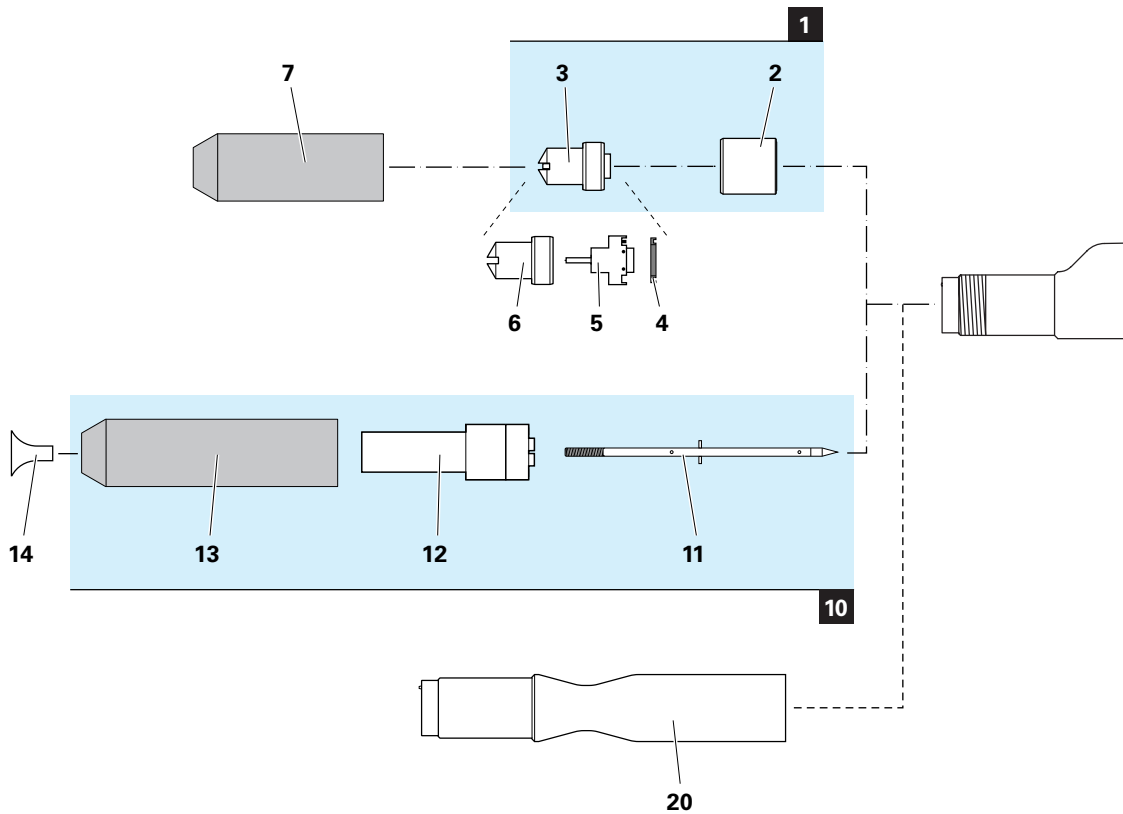

\* Please indicate length required  
 # Wear parts

Figure 13

**NOTES:**

© Copyright 2000 ITW Gema AG.  
All rights reserved.

This publication is protected by copyright. Unauthorized copying is prohibited by law. No part of this publication may be reproduced, photocopied, translated, stored on a retrieval system or transmitted in any form or by any means for any purpose, neither as a whole nor partially, without the express written consent of ITW Gema AG.

OptiTronic, OptiGun, EasyTronic, EasySelect, EasyFlow and SuperCorona are registered trademarks of ITW Gema AG.

OptiMatic, OptiMove, OptiMaster, OptiPlus, OptiMulti and Gematic are trademarks of ITW Gema AG.

All other product names are trademarks or registered trademarks of their respective holders.

Reference is made in this manual to different trademarks or registered trademarks. Such references do not mean that the manufacturers concerned approve of or are bound in any form by this manual. We have endeavoured to retain the preferred spelling of the trademarks, and registered trademarks of the copyright holders.

To the best of our knowledge and belief, the information contained in this publication was correct and valid on the date of issue. ITW Gema AG makes no representations or warranties with respect to the contents or use of this publication, and reserves the right to revise this publication and make changes to its content without prior notice.

Printed in Switzerland

ITW Gema AG  
Mövenstrasse 17  
9015 St. Gall  
Switzerland

Tel.: +41-71-313 83 00  
Fax.: +41-71-313 83 83

E-Mail: [info@itwgema.ch](mailto:info@itwgema.ch)  
[www.itwgema.ch](http://www.itwgema.ch)