

Operating Instructions

CRS-D Powder Coating Booth

CRS-D Booth with Filter Cartridges

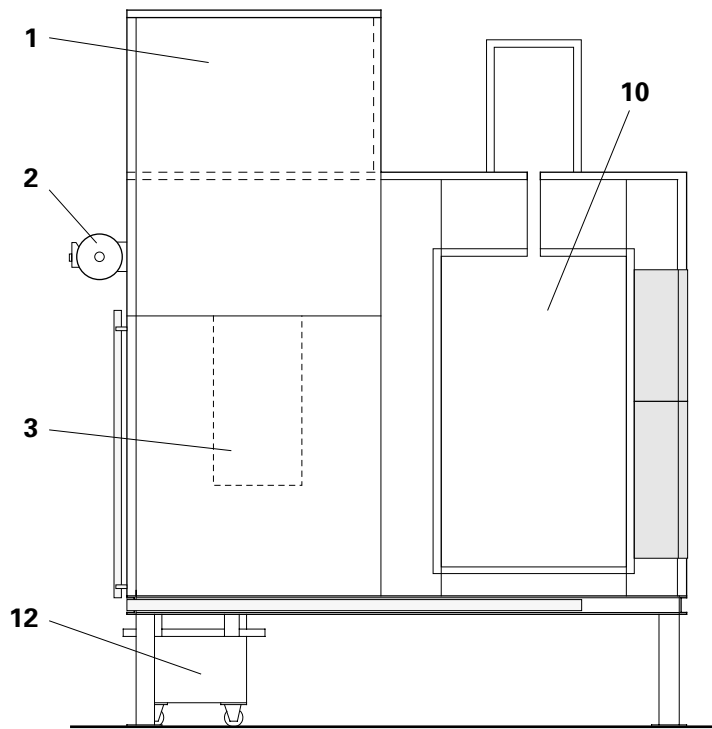

- 1 Exhaust air unit / Fan housing
- 2 Pressure tank
- 3 Filter cartridge
- 4 Pneumatic panel
- 5 Sieve pressure regulation
- 6 Fluidization pressure regulation
- 7 Prefluidization pressure regulation
- 8 Filter cartridge pressure regulation
- 9 Switch cabinet with operating panel
- 10 Coating area
- 11 Booth entry / exit
- 12 Powder recovery

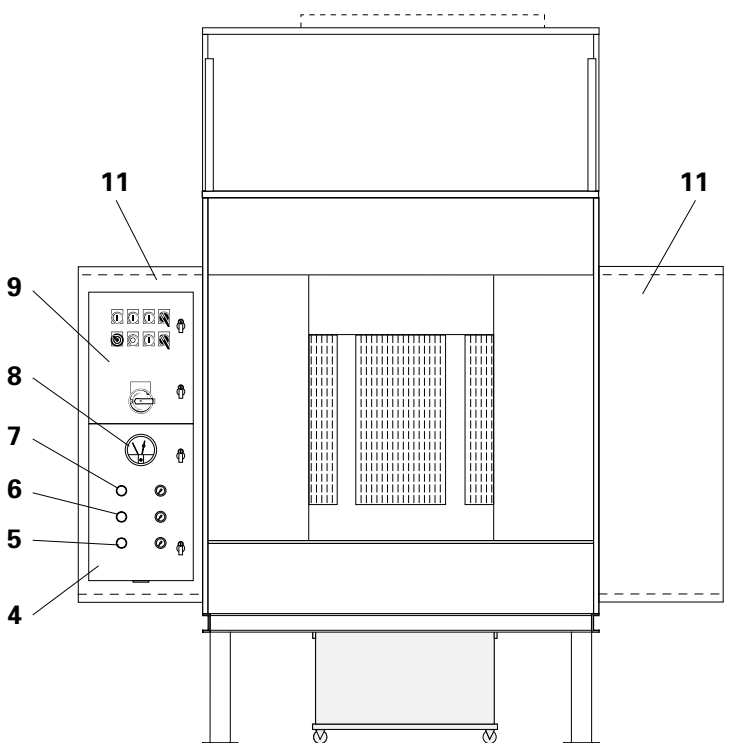

Please keep this page folded out when studying the documentation.

Safety Recommendations

Installation

The services and facilities to be provided by the customer should be installed according to local safety regulations.

Ground connections

The ground connections of the booth should be checked each time the equipment is put into operation. The grounding must be connected to the base of the booth by the customer. Make sure that the workpieces, and all other systems are also properly grounded.

Inspection check

Before switching on the booth, check the following points :

- The powder hopper is in place, the toggle catches are engaged and locked in; the pneumatic, and powder hoses are connected.
- The filter pads on the fan housing are not contaminated - contamination indicates a defect filter cartridge (See also the maintenance schedule, page 10).

Entering the booth/Booth cleaning

In order to protect personnel when entering the booth for inspection, and cleaning purposes, the switch - **S01** must be actuated. This switch starts ventilation, however the electrostatic control units, and other systems are locked and cannot be started.

Repairs

Repairs inside the booth (coating area) may only be performed after the booth is switched off.

Repairs should only be performed by trained personnel.

Table of Contents

	Page
Description of Function	1
Field of Application	1
Operating Principle	1
Exhaust Air System (Recirculating air)	2
Filter Cleaning	2
Powder Circuit	3
Powder Trolley	3
Power Recovery Hopper	3
Powder level too low	4
Start-Up	4
Preparation for Start-Up	4
Positioning the Powder Trolley / Recovery Container	4
Filling the empty Powder Trolley	5
Carrying out a Start-Up	5
Adjusting the Powder Fluidization	6
Setting and adjusting of the air blast parameters, and the duration for prefluidization	6
Operation	8
Function check	8
Start-up	8
Safety Recommendations	8
Switching the booth ON	8
Switching the booth OFF	9
Switching the lighting ON/OFF	9
Filter cleaning	9
Colour change	9
Maintenance	10
Maintenance schedule	10
Coarse booth cleaning	11
Booth cleaning	11
Cleaning the powder trolley	12

Table of Contents (continued)

	Page
Replacing Spare Parts	13
Replacing the Bulbs in the Push Buttons, and Warning Lamps	13
Replacing a Filter Cartridge	14
Replacing a Rotating Nozzle	14
Replacing a Filter Pad (Fan Housing)	14
Replacing a Solenoid Valve (Pressure tank on the rear of the booth)	15
Replacing a Pressure Gauge of the Pressure Monitoring	15
Function Check	16
Booth with Powder Trolley	16
Booth with Powder Recovery Container	17
Trouble Shooting Guide	18
Technical Data	19
Switch Cabinet	
Operating Elements	
Safety Recommendations	

CRS-D Powder Coating Booth

Functional Description

Field of application

CRS Manual powder coating booths with filter cartridges are used to electrostatically coat any type of workpiece in small batch production as they are designed to be operated manually as part of the coating system. The booth is integrated into the conveying chain. The workpieces suspended on the conveyor chain are coated as they pass through the coating area **(10)**.

CRS = Compact Recovery System

CRS Manual powder coating booths with filter cartridges are well suited for coating with plastic powders.

Operating Principle

The booth function is characterized by :

- protecting the coating process from external influences, and the cleanliness of the booth surroundings, and
- recovery of oversprayed powder.

It is based on a powerful exhaust air system which draws air from the booth through the filter cartridges **(3)**, see the drawing on the outer front fold-out page).

The resulting negative pressure produces an air-flow from the outside of the booth to the inside, thus preventing powder from escaping into the environment.

The powder adhering to the outside of the filter drops down into the booth and then into a powder recovery trolley for subsequent re-use.

In order to have a full understanding of the operations the booth functions are described individually in the following sections.

Exhaust Air System (Recirculating air)

The fans (4) of the exhaust system are located in the fan housing (1) above the filter cartridges (2). Air is sucked from the interior of the booth, passing through filter cartridges and is returned to the environment through the filter pads (3) as clean air.

The filter pads in the fan housing are intended for visual inspection only. Should one of the filter cartridges become damaged or develop a leak, powder will be deposited on this filter stage.

The efficiency of the exhaust system depends on how severely the filter cartridge is clogged. For this reason the suction efficiency is determined and indicated by measuring the differential pressure between the clean air side and the booth environment (pressure monitoring). Rising pressure indicates increasing clogging of the filter cartridges.

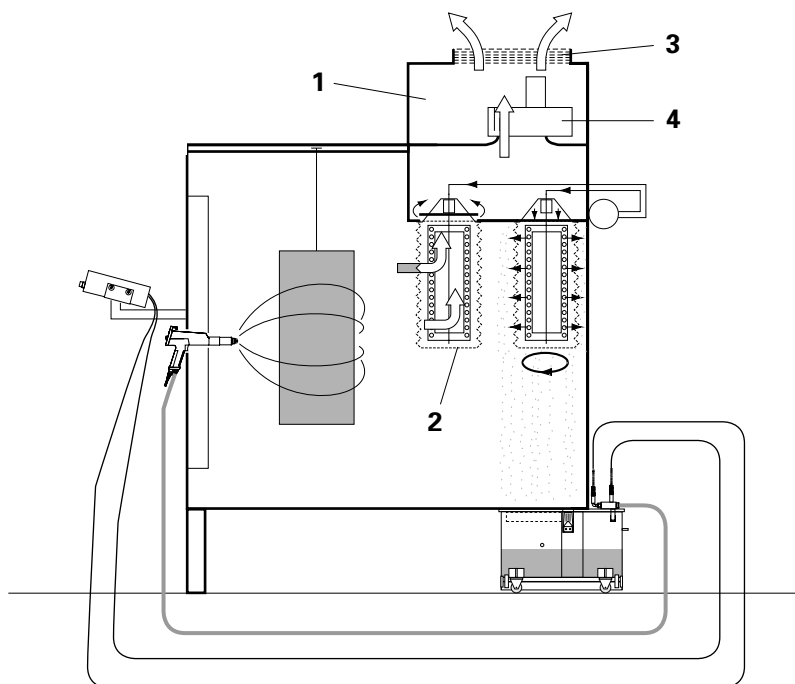

Filter Cleaning

Each filter cartridge is equipped with a cleaning device. The filter cartridges (2) are cleaned while the booth is in operation. Cleaning is activated automatically when the booth is switched on and remains active until the booth is switched off.

The cartridges are cleaned by compressed air injected by rotating nozzles inside the cartridges. The powder drops onto the floor of the booth from where it is then loaded into the powder trolley or the powder recovery container.

The air for cleaning the filters is supplied from the pressure tank on the fan housing.

The cleaning process, and consequently the blast duration per filter cartridge, and the pause before the next cartridge is blasted off, are monitored by an electronic control circuit. The air blast time, and the pause time are preset by the factory (Limit = 1,4 kPa).

Powder Circuit

The powder truck is a prerequisite for working with a closed powder circuit. In the closed powder circuit the guns are connected to the powder trolley. The powder is fed from the powder truck via the gun to the workpiece. The over-sprayed powder drops to the bottom of the booth or is retained by the filter cartridges. This powder also drops down inside the booth when the filters are blasted off. The powder is scraped manually into the powder trolley where it is returned for re-use in the coating process.

If the booth is equipped with a powder recovery container coating in a closed powder circuit is not possible. Powder is fed into the hopper manually and is not directly available for coating.

Powder Trolley

The powder trolley is installed at the rear of the booth, under the booth floor.

The powder trolley can be rolled out, and is pressed against the booth in its working position.

The powder in the hopper is fluidized, and then sucked up by the injector and fed to the gun.

The powder supply is monitored by a level sensor. The level control activates an alarm signal in the event of a powder shortage.

Powder which has dropped to the bottom of the booth is fed back into the powder hopper through a vibrating sieve. Dirt, and contamination is eliminated by the sieve. The sieve can be switched on when required (Button - **S13**).

Powder Recovery Trolley

If the booth is equipped with a powder recovery container instead of a powder trolley, working with a closed powder circuit is not possible. The recovery container is not equipped with a fluidizing bed, vibrating sieve or injectors, therefore the powder cannot be processed for direct re-use. The recovery container can be rolled out, and is pressed directly against the working position.

Powder level too low

An alarm is activated when the level of the powder in the powder trolley sinks below a certain level on the lower level sensor, and at the same time a warning lamp (**H6**) illuminates on the control cabinet indicating a powder shortage.

Start-Up

Attention!!

Before starting up it may be necessary to run a Function Check (see page 8).

A start-up should be carried out before the start of every shift, and after the booth has been standing idle for long period.

Preparation for Start-Up

Procedure :

- Observe the safety regulations (see front inner cover fold-out page)
- Carry out the following checks and, if necessary, carry out the points listed below (the procedures are described in more detail below) :
 - Position the powder trolley/recovery container (see below).
 - Fill the powder trolley with powder (see page 5).
 - If necessary, top up with powder (see page 5).
 - Check that the filter cartridges are firmly seated, tighten the star grips.
 - Replace the filter cartridges (at colour changes or if defective, see page 14).

Positioning of the Powder Trolley/Recovery Container

Procedure :

- Push the powder trolley under the booth floor all the way to the stop position.
- Connect the clamping levers and lock-in.
- Connect the air hoses for fluidization, and the vibrating sieve.
- Connect the level sensor control cable.
- Connect the injector.

Attention!!

Take care that the trolley does not drop down when it is being lowered.

Filling the empty Powder Trolley

The following section describes how the empty powder trolley is to be filled.

The powder trolley can only be filled manually. If necessary, coarse cleaning of the booth should be done before filling the trolley.

In order to eliminate contamination in the powder; fresh powder should not be filled directly into the trolley. The following procedure is recommended :

- Switch on the booth (Push button - **S2**).
- Switch the electrostatic control unit off.
- Switch the sieve on (**S13**).
- Evenly distribute portions of fresh powder directly over the whole sieve.
The powder is passed through the sieve, thus removing any contamination.
- Repeat this procedure until the required amount of powder is in the container.
- Check the powder level through the control flap of the powder container.

Capacity of an empty powder container : Approximately 36 kg plastic powder (average value).

Attention !!

The abovementioned amount of powder must not be overstepped as the volume of powder increases when fluidized (DANGER of OVERFLOW).

Carrying out a Start-Up

Procedure :

- Enable the compressed air circuit, and check if the input pressure is set to 6 bar.
- Set the pressure for filter cleaning to 2,5-3 bar on the pressure reducing valve.
ATTENTION! This pressure must not be set higher, as the safety valve at the other end of the pressure tank will be activated!
- Switch on the booth (see also Safety recommendations) : Switch on the main switch - **Q0**, the key switch - **S01**, and press the button - **S2**.
- Set the operating parameters on the pneumatic panel :

Pneumatic Panel

- Sieve - Pressure reducing valve (**4**) :
approximately 2-3 bar, depending on the type of powder.
- Continuous fluidizing - pressure reducing valve (**3**) :
approximately 0,5-1,5 bar, depending on the

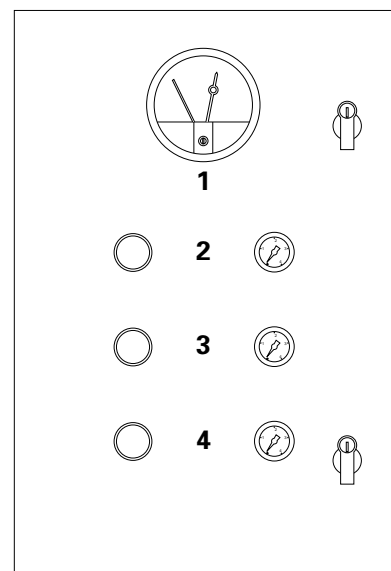

type of powder, the powder should lightly “boil” (this can be checked through the inspection flap of the powder container).

- Prefluidization - Set the pressure reducing valve **(2)** to approximately 3-5 bar.
- Check the fluidizing and readjust, if necessary (see the next section)
- Switch off the booth.

Adjusting the Powder Fluidization

Powder fluidizing is performed in two phases. In the first phase, the prefluidization, the powder is intermixed during approximately 40 seconds by strong air blasts and thus prepared for continuous fluidization.

In the second phase, continuous fluidization, an air stream flows continuously from the bottom through the powder so that it is maintained in a fluid-like condition (the powder “boils” lightly). With the start of the second phase the system is operational. The changeover from phase one to phase two takes place automatically.

The adjustment of the required air pressure for prefluidization, and continuous fluidization, and the optimum adjustment of the air blast parameter for prefluidization, depends on the type of powder, the air humidity, and the ambient temperature. For this reason only arbitrary settings for fluidization are possible and these should be readjusted, according to the type of powder being used, from previous experience.

The air pressure values for prefluidization, and continuous fluidization can be adjusted on the pneumatic control panel. The setting, and adjustment of the air blast parameter for prefluidization, and the duration of the prefluidization are carried out on the corresponding time relay (K87T) in the switch cabinet (see the next section).

Setting and Adjustment of the Air Blast Parameters, and the Duration for Prefluidization.

Configuration diagram - Switch Cabinet

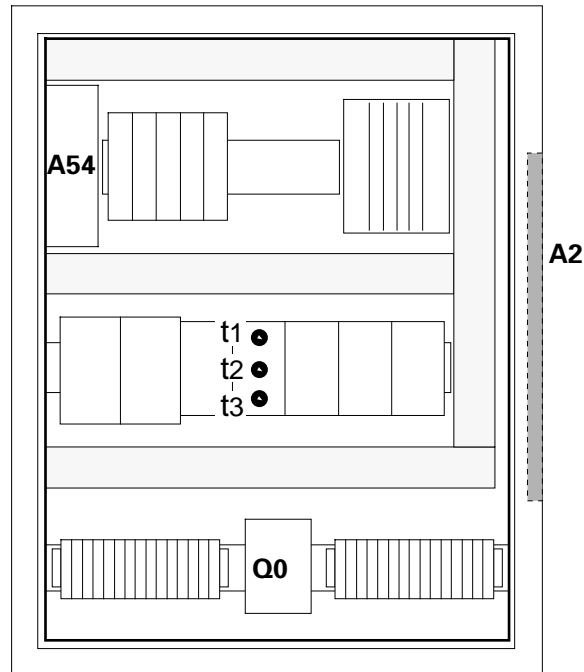

Designation :

K87T Relay for prefluidization, with the following potentiometers :

t1 time setting for the duration of the air blasts.

t2 time setting for the duration of the pauses.

t3 time setting for the duration of the total prefluidizing phase.

Procedure :

- Switch off the booth.
- Open the control cabinet (the electrical components are positioned as shown in the diagram above).
- The relay for prefluidization adjustment/setting (three potentiometers on relay - K87T) :
 - Time setting relay - t1 : 0,3 s (approximate value)
 - Time setting relay - t2 : 0,4 s (approximate value)
 - Time setting relay - t3 : set to the empirical value for the type of powder being used (approximately 40 s).
 - Close the switch cabinet.
 - Start up the booth and check the fluidization in the powder container (through the inspection flap of the powder container).
 - Readjust the time settings, if necessary.

Operation

Function check

Check the grounding of the booth and other connected equipment, if necessary, ground.

Before starting work carry out a Function Check (see page 16).

Start-Up

A Start-Up should be carried out after the booth has stood still for a long period or when starting work.

Safety Recommendations

The Safety Recommendations on the inner front fold-out page are to be strictly observed.

Switching the Booth On

Procedure :

- Switch on the main switch - **Q0**
- Switch on the key switch - **S01** : The control unit is activated, lamp - **H0** illuminates and the key switch - **S01** returns to its original condition.
- Press button - **S2** : The fan starts up; after the acceleration phase the prefluidization in the powder container starts up.

After the prefluidization phase has finished the unit switches to continuous fluidization, the powder level control is activated and interlocked units are released (Electrostatic control unit, etc).

- Check the continuous fluidization (through the inspection flap of the powder container). The powder must lightly "boil", adjust the valve (**6** - inner rear cover fold-out page) on the pneumatic control panel (see Pneumatic panel - outer rear cover fold-out page).
- Switch on the electrostatic control equipment and all booth units which are not already switched on. The gun begin to spray when the trigger is pulled.

Switching the Booth Off

Procedure :

- Switch off all electrostatic control equipment and booth units.
- Press button - **S1**.
- Switch off the main switch - **Q0** : Lamp - **H0** goes out.
- Check the powder container sieve for contamination and clean, if necessary.

Switching the Lighting ON/OFF

CRS Manual powder coating booths are fitted with strip lighting in the roof of the booth as standard equipment.

The light is switched on with the switch - **S6**. A prerequisite for this is that the key switch - **S01** is already switched on.

Filter Cleaning

The filter cartridges are cleaned cyclically during booth operation. The cleaning cycle must be released manually. The cycle time is preset at the factory.

The differential pressure is indicated on the pressure gauge (**8** - see Pneumatic panel, inner rear cover fold-out page), whereby the upper pressure limit is 1,4 kPa. The adjustment of the cycle time is described in the circuit diagram.

Colour Change

Procedure :

- Clean the booth (see page 11).
- Clean out the powder trolley thoroughly (see page 12).
- Clean the injector separately, blow the hose through, and clean the gun according to the separate operating instructions.
- Replace the filter cartridges (see page 14).

Maintenance

Maintenance Schedule

Maintenance Intervals

Daily or after each shift :

- Blow the hose through with compressed air.
- Clean the outside of the gun, and check parts for wear.
- Coarse clean the booth (see "Coarse booth cleaning", page 11).
- Check the vibration sieve in the powder trolley and remove any contamination.

Weekly :

- Blow off the filter cartridges and check for damage, if necessary, replace (see page 14, "Replacing a filter cartridge").
- Check the filter pads in the exhaust air exit of the fan housing. Large powder deposits indicate a defect filter or filter(s), if necessary, replace the damaged filter or all the filters (see page 14, "Replacing a filter cartridge").
- Clean the booth completely (No wet cleaning).

Attention !! A thorough booth cleaning should not take place immediately after the powder trolleys have been filled with fresh powder - Danger of overflow !!

- Empty the powder trolley/powder recovery container and clean (see "Powder trolley cleaning").
- Check the oil/water separator and empty, if necessary (if oil is present, the customer should check the air compressor).

Biannually :

- Flush the air lines of the pressure gauges with compressed air.

Attention !! Disconnect the air lines of the pressure gauge (8 - inner rear cover fold-out page) flush out in the following direction : Pressure gauge —> Measuring point.

Attention !!

All parts which are to be replaced after maintenance, such as filter cartridges, filter pads, etc, are available as spare parts. Please refer to the Spare Parts List.

Coarse Booth Cleaning

Attention !!

A coarse booth cleaning should not take place immediately after the powder trolleys have been filled with fresh powder.

Filter cartridges must **never** be cleaned with compressed air guns !!

Procedure :

- Switch on the booth.
- Check the vibration sieve of the powder trolley and clean up any contamination with an industrial vacuum cleaner.
- Knock on the outside of the booth walls so that any powder adhering to the inside falls to the booth floor.
- Push the powder onto the sieve of the powder trolley manually.

Booth Cleaning

Attention !!

Booth cleaning should not take place immediately after the powder trolleys have been filled with fresh powder - Danger of overflow !!

Filter cartridges must **never** be cleaned with compressed air guns !!

Procedure :

- Switch on the booth.
- Turn the switch - **S4** (Rapid filter cleaning) to "1" and wait until all the filter cartridges have been cleaned off, then turn the switch - **S4** to "0".
- Check the vibrating sieve of the powder trolley and clean up any contamination.
- Clean the booth walls with a squeegee.
- Push any accumulated powder manually onto the sieve of the powder trolley and sieve the powder.

Cleaning the Powder Trolley

Use the following procedure to clean the powder trolley :

- Start up the booth.
- Start the vibrating sieve with the switch - S13
- Wait until the vibration time has finished, then switch off the booth.
- Lower the powder trolley and remove it from the booth.

Attention : Do not let the powder trolley fall when lowering !

- Clean the vibration sieve with an industrial vacuum cleaner, remove it and place next to the trolley.

Attention : Do not release the air connection of the vibrator yet; pull out just enough hose so that the sieve can be displaced.

- Remove the injector mounting plate, clean it and place out of the way. Do not disconnect the hoses at the injector.
- At a colour change only : remove the injector and clean separately.
- Empty the powder into a plastic bag with a plastic scoop. Brush the remaining powder together with a soft brush and pour into the plastic bag.
- Clean the powder container with an industrial vacuum cleaner.
- Release the air connection of the sieve, check the sieve for damage, if necessary replace.
- Clean the inside, and outside of the container with a clean, dry cloth.
- Thoroughly clean the fluid plate on the inside of the container with an industrial vacuum cleaner.
- Check the condition of the rubber seals, the profile of the sieve frame, and injector plate seating, if necessary, replace.
- Reassemble the container.

Replacing Spare Parts

- The replacement of spare parts should only be carried out by trained personnel!
- The booth must be switched off before replacing spare parts!

Spare parts should be ordered according to the Spare Parts List.

Replacing the Bulbs in the Push Buttons, and Warning Lamps

(Control Panel on the Control Cabinet)

Procedure for replacing the bulb in a push button :

- Unscrew the protective ring (**R**)
- Remove the plastic cap (**K**) by pulling it towards the front.
- Pull off the white inner cap (**I**). Caution : Sealing ring.
- Replace the bulb with the aid of the bulb extractor supplied and reassemble the push button.

Procedure for replacing the bulb in a signal lamp :

- Remove the plastic cap (**KG**).
- Pull off the white cap (**IG**). Replace the bulb with the aid of the bulb extractor supplied and reassemble the signal lamp.

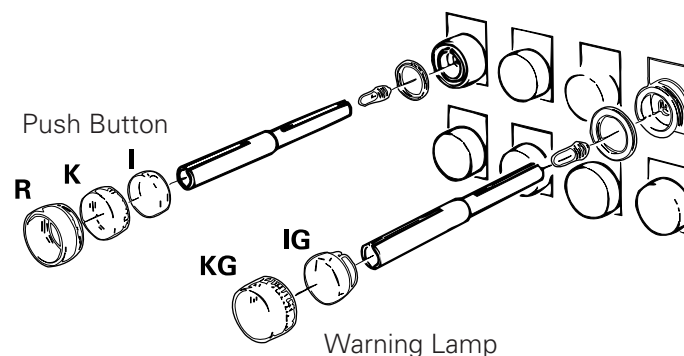

Replacing a Filter Cartridge

A rapid filter cleaning operation should be carried out before replacing a filter cartridge :

- Start up the booth.
- Switch on the switch - **S4** (Rapid filter cleaning) and wait until all filter cartridges have been blasted off and then turn off switch - **S4**.
- Switch off the booth.

Procedure for changing a filter :

If a filter cartridge is damaged, but the damage cannot be found, then the whole set of filter cartridges must be replaced. Access to the filter cartridges is at the rear of the booth.

- Unscrew the four milled nuts on the rear of the booth and remove the rear wall of the booth and place away from the booth.
- Hold the filter (**3**) and unscrew the star grip (**1**) completely. Attention !! - Washer (**2**) !
- Remove the filter downwards and put in a safe place.
- Clean all parts, including the rotating nozzle (**4**), and sealing flange (**6**).
- Fit the new filter cartridge; rubber side of the washer (**2**) upwards.

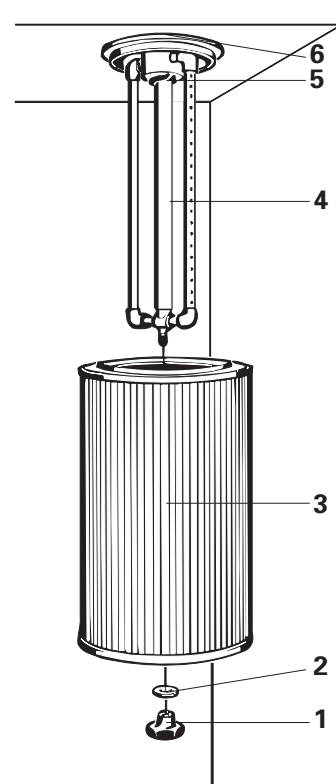

Replacing a Rotating Nozzle

The filter cartridge must be removed before the rotating nozzle (**4**) can be dismantled (see drawing above).

Procedure :

- Remove the Seeger ring (**5**).
- Pull the rotating nozzles (**4**) downwards.
- Fit the new rotating nozzles.
- Refit the Seeger ring (**5**).

Replacing Filter Pads (Fan housing).

Procedure :

- Open the retaining grid on the exhaust air housing.
- Check the clean air chamber (powder deposits) and clean, if necessary.
- Fit a new filter pad and close the retaining grid.

Replacing a Solenoid Valve (Pressure tank on the rear of the booth)

The solenoid valves are mounted on the pressure tank on the exhaust air unit and numbered according to the allocation diagram.

Procedure :

- Vent the compressed air tank : Close the pressure reducing valve (**1** - see drawing below) on pressure the tank.
- Slowly open the safety valve (**2**) and wait until the all air is exhausted from the tank.

ATTENTION!! The lead seals **must not** be removed!!

- Remove the hose from the defect solenoid (When more than one solenoid has to be replaced the air hoses should be properly identified).
- Release the screw of the plug and pull off the plug (**3**) and cable.
- Unscrew the solenoid from the tube.
- Fit the new solenoid and connect (Seal the end of the tube with Teflon tape or Locktite - Blue).

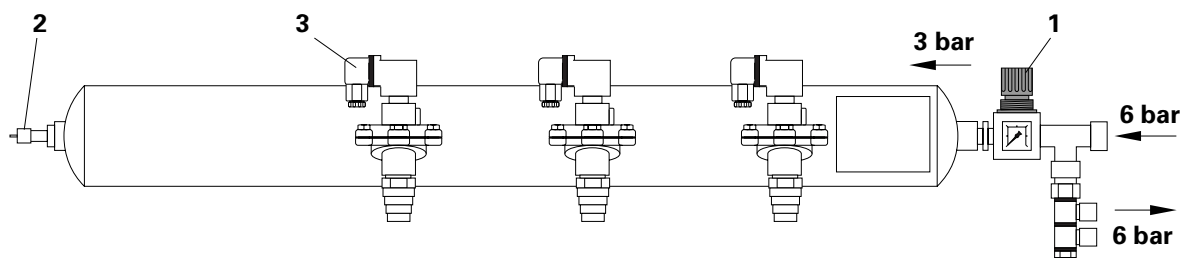

Replacing a Pressure Gauge of the Pressure Monitoring.

(Differential pressure of the filter cartridges)

Procedure :

- Open the pneumatic control panel.
- Loosen the pressure gauge connection and mark.
- Dismantle the pressure gauge.
- Blow the air hoses through in the direction of the measuring point.
- Fit the pressure gauge and connect according to the connection diagram

Function Check

Carry out a function check :

- after replacing electrical spare parts of the booth.
- after working on the control unit or electrical parts of the booth.

Booth with Powder Trolley

Prerequisites for making a function check :

- Powder trolley is empty
- Switch - **S4** (Rapid filter cleaning) : Off

Procedure :

- Switch on the main switch - **Q0** : It should not be possible to switch on the electrostatic control unit.
- Switch on the key switch - **S01**; Lamp - **H0** must illuminate. It should not be possible to switch on the electrostatic control unit.
- Press button - **S2** : The exhaust air fan must accelerate; after the acceleration phase :
 - The prefluidization should switch on.

After approximately 40 seconds :

- The prefluidization should switch to continuous fluidization.
- The electrostatic control unit should be ready for operation.
- The powder level monitoring should switch on and indicate that the powder trolley is empty; the signal lamp - **H6** illuminates, and the alarm sounds.
- Switch off the alarm by removing the plug from the powder trolley
- Press button - **S13** : The sieve must start up.
- Turn switch - **S4** (Rapid filter cleaning) to "1" and check that all rotating nozzles function correctly (listen for noise); turn the switch to "0".
- Press button - **S1** : The booth must switch off.

Booth with Powder Recovery Container

Procedure :

- Switch the main switch - **Q0** on : It should not be possible to switch on the electrostatic control unit.
- Switch on the key switch - **S01**. The lamp - **H0** should illuminate, it should not be possible to switch on the electrostatic control unit.
- Press button - **S2** : The exhaust air fan must accelerate; after the acceleration phase the electrostatic control unit should be ready for operation.
- Turn switch - **S4** (Rapid filter cleaning) to "I" and check that all rotating nozzles function correctly (listen for noise); turn the switch to "0".
- Press button - **S1** : The booth should switch off.

Trouble Shooting Guide

Attention !!

Repairs to the electrical parts of the booth must only be undertaken by trained personnel.

Faults	Causes	Remedies
Alarm is activated. Lamp - H6 illuminates :	Powder shortage in the powder trolley.	Remove the plug from the powder trolley, fill with fresh powder (see page 5).
The booth switches off. Lamp - H8 illuminates :	Fault in the fan motor, the motor protection is activated.	Switch off the main switch - Q0 , let the motor cool down, reset the corresponding motor protection (see circuit diagram) and switch on the booth; when the fault occurs repeatedly, please contact a GEMA-VOLSTATIC Service Centre.
Powder in the filter pads of the fan housing.	Filter cartridge defect.	Replace the defect filter cartridge or the complete set of cartridges (see page 14).

Technical Data

(Subject to change)

Electrical connection :

Voltage : 3x380 V / 50 Hz

Other voltages, and frequencies are available.

Fan performance :

2,2 kW with 4 Filter cartridge.

Booth differential pressure :

Max. 1,4 kPa

Compressed air connection :

Input pressure :

Max. 12 bar

Min. 3,5 bar

Recommended input pressure :

7 bar

Water vapour content :

Max. 1,3 gr/m³

Oil vapour content :

Max. 0,1 ppm

Compressed air consumption :

Rinsing air per filter trolley :

Max. 12 Nm³/h

Prefluidization - powder trolley :

Approx. 43 Nm³/h

Vibrating sieve :

Approx. 15 Nm³/h

Documentation CRS-D

© Copyright 1993 GEMA-VOLSTATIC AG, CH-9015 St. Gall.

All technical products from GEMA-VOLSTATIC AG are constantly being developed based on our continuing research and applications.

The data found in this publication may therefore change at any time without prior notification.

Printed in Switzerland

Please keep this page folded out when studying the documentation

Switch Cabinet

Operating Elements

- Q0 Main switch
- S01 Key switch : Mains voltage - ON
- S1 Booth - OFF
- S2 Booth - ON
- S4 Rapid filter cleaning - ON/OFF
- S6 Lighting
- S13 Sieve
- H0 Control voltage - ON
- H4 Filter cleaning
- H6 Powder container - Empty
- H8 Motor fault

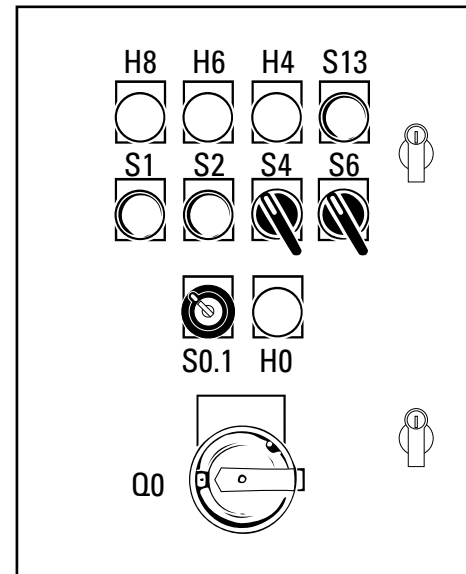

S = Switch/Push Button H = Warning lamp

The switch cabinet is fitted with the corresponding operating elements dependent on the configuration requested by the customer.