

OPERATING INSTRUCTIONS POWDER COATING BOOTH

CRS-L/CRS-E

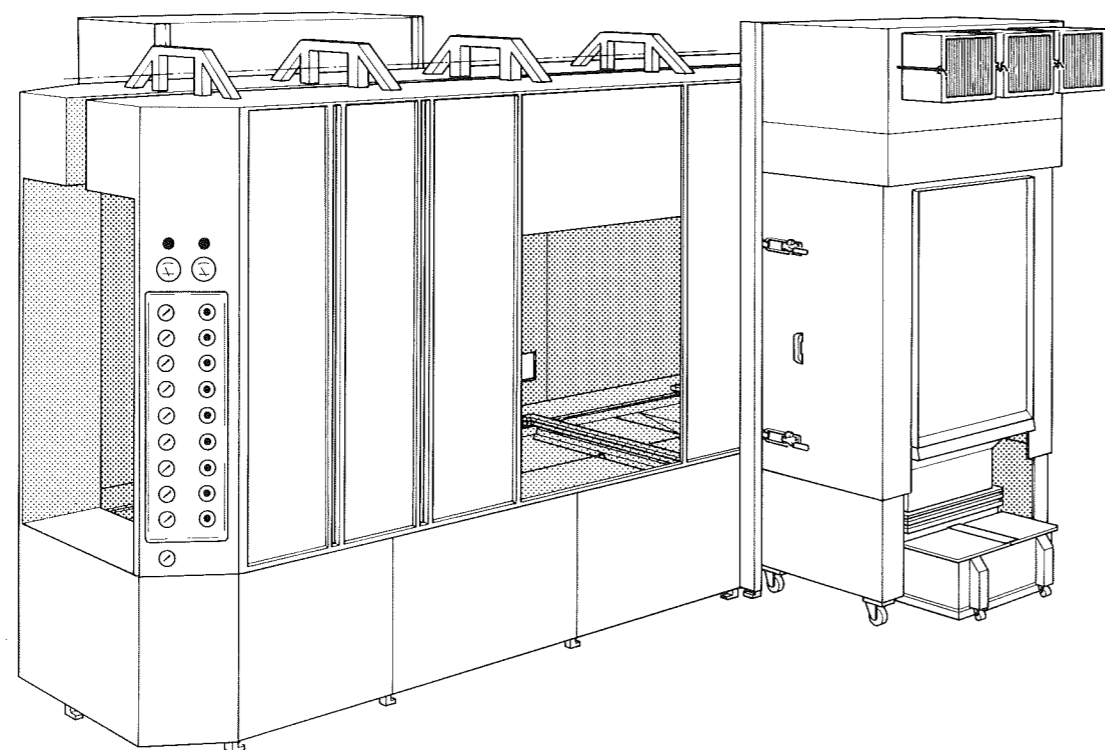

Please keep this page unfolded while you study this documentation!



RANSBURG-GEMA AG

Mövenstrasse 17
CH-9015 St. Gallen
Schweiz

Telefon (071) 32 15 45
Telex 77 402 rgema ch
Telefax (071) 31 31 05

**CRS BOOTH WITH SINTER
LAMELLA FILTERS**

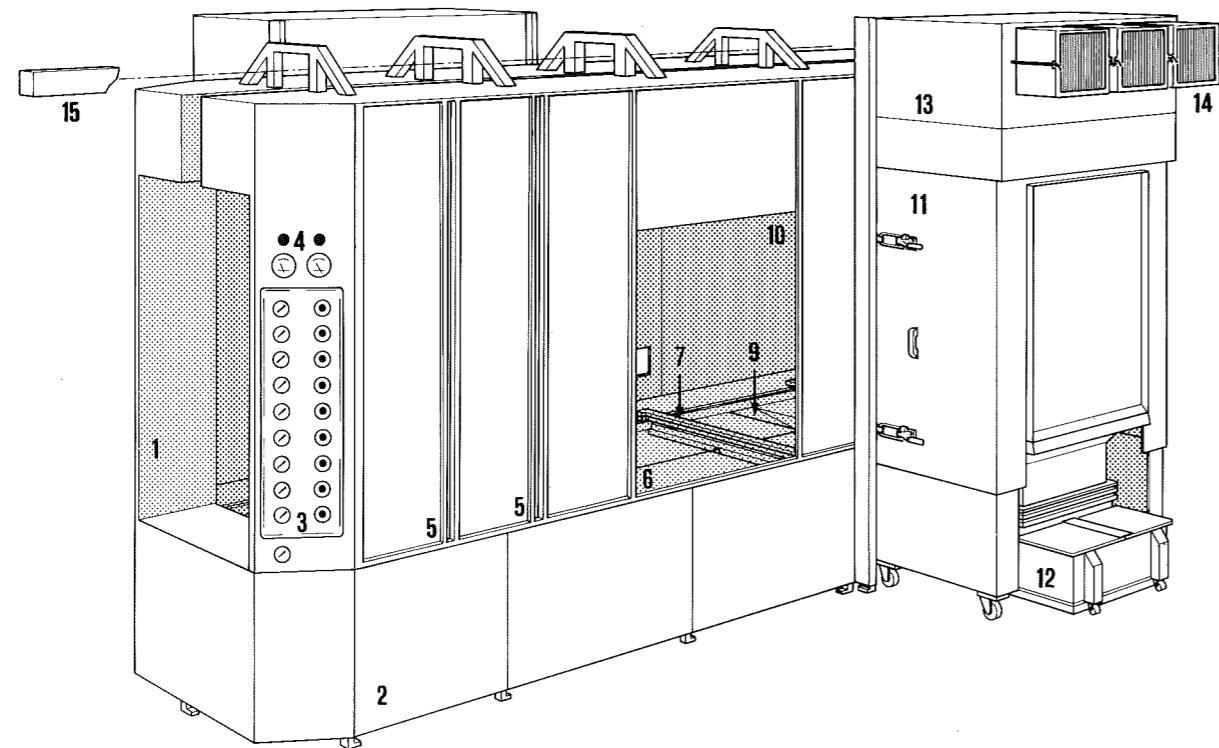

- 1 Booth entrance
- 2 Booth base
- 3 Pneumatic panel (see also foldout page at end)
- 4 Pressure gauge (sinter lamella filters)
- 5 Gun traversing slots
- 6 Trough (booth floor)
- 7 Squeegee
- 9 Fluidizing trough
- 10 Opening for manual coating
- 11 Filter trolley
- 12 Powder truck (integrated)
- 13 Ventilator housing with silencer hood
- 14 Clean-air filter elements (secondary filter)
- 15 Chain conveyor (supplied by customer)
- 17 Sinter lamella filters
- 26 Open/close valve for sealing frame to powder truck
- 30 Open/close valve for sealing frame to filter trolley

QUICK-REFERENCE GUIDE

(Please unfold the last page showing the control panel and the pneumatic panel).

Prior to start-up

- Before you switch on the coating system, a start-up procedure or functional check should be performed
- Please read the safety recommendations (next page)

Switching the booth ON: (see also page 22)

- Turn on the master switch Q0
- Turn keylock switch to position S01: control is enabled, H0 lights up
- Press button S2: ventilator(s) start(s); as soon as the pilot lamp H1 lights up, the following are activated:
 - * prefluidization and after 40 seconds continuous fluidization as well as all interlocked system components
 - * filter cleaning
- Check the fluidization and switch on all system components such as the ES control equipment (electrostatic control unit), virgin powder feed, etc.

Switch the booth OFF: (see also page 23)

- Switch off the ES control unit and all external system components
- Press button S1: pilot lamp H1 switches off
- Turn off master switch Q0: pilot lamp H0 switches off

Alarm: (see also troubleshooting guide, page 36)

The signal horn is activated in the following situations:

- Powder truck empty, i.e. as soon as the powder level drops below the lower level sensor
- Pressure rise in the exhaust air system (pressure differential of 140 mm HH is exceeded)
- Squeegee malfunction

The alarm can be acknowledged with switch S5.

Important

The maintenance schedule on page 25 should be conscientiously followed.

SAFETY RECOMMENDATIONS
-----**Installations**

The services and facilities provided by the owner should be installed in accordance with the local regulations.

Ground connection

The ground connection of the booth should be checked each time the equipment is put into service. The ground must be connected by the owner to the base of the booth. Also make sure that the workpieces on all other system components are properly grounded.

Control inspection

Before you switch on the booth, check the following items:

- No foreign objects in the powder recovery trough (6)
- Powder truck pushed in
- Filter trolley engaged, toggle joints locked, pneumatic lines connected
- Sealing frame between ventilator box and filter trolley and between filter track and powder truck lowered

Entering the booth

In order to protect the personnel, switch S4 must be actuated when the booth is entered for inspection and cleaning purposes. This switch starts the ventilator, however the ES control units and other system components are blocked and cannot be started.

When you enter the booth make sure that you do not step on the squeegee or the squeegee slide rails.

Repairs

Repairs inside the booth (coating space) may only be performed after switch S4 (booth cleaning) has been actuated. Repairs should only be performed by skilled technicians.

TABLE OF CONTENTS

| | Page |
|---|-----------|
| FUNCTIONAL DESCRIPTION | |
| - Field of application..... | 1 |
| - Principles of operation..... | 1 |
| - Versions..... | 2 |
| - Coating procedure..... | 2 |
| - Exhaust air system..... | 3 |
| - Filter cleaning..... | 4 |
| - Squeegee..... | 4 |
| - Powder below minimum level..... | 5 |
| - Manual coating..... | 5 |
| - Virgin powder hopper..... | 6 |
| | |
| CRS BOOTH WITH FLUIDIZING CANAL AND INTEGRATED POWDER TRUCK..... | 7 |
| - Filter trolley for coupling to the fluidizing canal. | 8 |
| - Powder truck for integration below the filter trolley..... | 9 |
| | |
| CRS BOOTH WITHOUT FLUIDIZING CANAL, WITH CENTRAL POWDER TRUCK..... | 10 |
| - Filter truck for booths without fluidizing canal... | 11 |
| - Powder truck for central arrangement below the booth floor..... | 12 |
| | |
| START-UP PREPARATIONS | |
| - Overview..... | 13 |
| - Coupling the filter truck..... | 13 |
| - Installing the powder truck below the filter trolley..... | 14 |
| - Installing the powder truck below the booth floor.. | 14 |
| - Checking the squeegee in booths with or without fluidizing canal..... | 15 |
| - Filling the empty powder truck..... | 16 |
| | |
| START-UP PROCEDURE | |
| - Switching on the booth..... | 19 |
| - Setting the operating parameters on the pneumatic panel..... | 19 |
| - Adjusting the powder fluidization..... | 20 |

-
- Adjusting/readjusting the time parameters for the prefluidization..... 21

OPERATION

- Checks before the booth is switched on..... 22
- Switching on the booth..... 22
- Switch off the booth..... 23
- Filter cleaning..... 23
- Powder recovery..... 23
- Replenishing with virgin powder..... 23

MAINTENANCE

- Maintenance schedule..... 25
- Rough booth cleaning..... 26
- Booth cleaning..... 26
- Procedure for removing the squeegee..... 27
- Cleaning the powder truck..... 28

REPLACEMENT OF SPARE PARTS

- General..... 29
- Replacing the push button lamps and the signal lamps on the control cabinet..... 29
- Replacing the clean-air filter elements..... 30
- Replacing the pressure reducing valves on the pneumatic panel..... 31
- Replacing the filter cleaning solenoid valve..... 32
- Replacing the pressure gauge..... 33
- Replacing the squeegee traction cable..... 34

FUNCTION CHECK

- Performing the functional check..... 35
- Preconditions for performing the functional check.. 35
- Procedure..... 35

TROUBLESHOOTING GUIDE..... 36

TECHNICAL DATA..... 38

OPERATOR CONTROLS..... 40

FUNCTIONAL DESCRIPTION

Field of application

CRS coating booths with sinter lamella filters are suited for electrostatic powder coating of any type of workpiece in quantity production. Since they are part of process-controlled coating systems, they are designed for fully automatic operation.

(CRS = Compact Recovery System)

CRS booths with sinter lamella filters are suited for coating with enamel powders and difficult-to-process plastic powders. (For other powder types see CRS booths with cartridge filters).

Principle of operation

The booth function is characterized by:

- Protection of the coating process from external influences and cleanliness of the booth surroundings
- Recovery of oversprayed powder, and
- Avoidance of explosible plastic powder/air mixtures inside the booth.

For keeping the booth surroundings clean and for preventing the buildup of explosible plastic powder/air mixtures, a powerful exhaust air system is used that draws air from the booth through the sinter lamella filters. The resulting negative pressure produces an air flow from the outside the booth to the inside, thus preventing powder from escaping into the environment which means that the surroundings of the booth are kept clean. The air flow also prevents the buildup of hazardous plastic powder/air mixtures.

The powder recovery is implemented by self-cleaning sinter lamella filters and the squeegee that pushes the oversprayed powder into the recovery trough.

The powder adhering to the filter surface drops on the booth floor or it is trapped by the sinter lamella filters. Depending on the model and position of the filter trolley, the powder cleaned off the filters drops either directly on the screen of the powder truck or it can flow from the filter trolley via the fluidizing bed into the booth trough.

The collected powder is pushed by the squeegee through the booth opening into the fluidizing trough from where it is transported via the sifter into the powder truck (also refer to sectional drawings of booth on pages 7 and 10). This powder is now again available for coating.

Versions

CRS booths are built from modular assemblies to suit the customer's requirements, i.e. the configuration is adapted to the planned application. Automatic operation is possible with a fully configured system.

CRS booths with sinter lamella filters are equipped with an integrated powder truck or with a central powder truck (see pages 7 and 10 respectively).

Booth versions

Booths with low exhaust air volumes are equipped with only one filter trolley (and not with two filter trolleys as shown on the foldout page).

Coating procedure

When the booth is switched on, the ventilator starts and after the acceleration phase switches the system components interlocked with the booth.

The system is ready for operation as soon as the other external components such as the conveyor chain, powder hopper, reciprocator, etc. have been switched on.

All operator functions on the control cabinet are now enabled and can be initiated.

The coating process can start. It is interrupted only in the event of a ventilator motor fault. Other faults are indicated by triggering an alarm or by switching on the signal lamp on the control cabinet.

The negative pressure and consequently the throughput of the exhaust system is monitored while the booth is in operation. If the air throughput drops, clogging of the filter plates is indicated (the differential pressure rises). When a preset lower threshold is reached, a warning lamp lights up on the control cabinet and an audible alarm is initiated.

The powder level in the truck is controlled by the level sensor. When the powder level drops below the upper sensor, the squeegee is activated after the preprogrammed time. It pushes the powder that has dropped to the bottom of the booth into the fluidizing trough (or through the booth opening) from where it drops on the oscillating sifter of the powder truck. The sifted powder is then again available for coating. If the recovered powder quantity is too small to cover the lower sensor in the truck, virgin powder is automatically fed from the powder hopper (option).

A powder shortage is indicated by a warning lamp on the control cabinet and/or by an audible alarm (powder shortage: see page 5). In booths that are not fully equipped, the powder must be replenished manually.

The booth control is equipped with an emergency stop function. When this function is activated, the booth and all interlocked system modules are switched off. The system must be restarted by operating the keylock switch.

Depending on the options selected by the customer, CRS booth may be equipped with a manual coating opening (10) in addition to the gun traversing slots. The manual coating openings can be used for precoating or touching up the workpieces.

For further explanation of the operating procedure, the individual booth functions are subsequently described in more detail.

Exhaust air system (recirculated air)

The ventilator of the exhaust system is located in the ventilator housing (13). The ventilator draws air from inside the booth and returns the clean air via the secondary filter (17) into the shop. In booths with large air throughput, the ventilator housing is equipped with a silencer hood (for technical data refer to page 38).

The volumetric suction capacity depends on the total opening of the booth. Depending on the required suction power of the exhaust system, the booth is equipped with one or two filter trolleys.

The efficiency of the exhaust system depends on how severely the sinter lamella filters are clogged. For this reason the suction efficiency is determined and indicated by measuring the differential pressure between the suction chamber and the exhaust side (pressure gauge (4)). Rising pressure indicates increasing contamination of the sinter lamella filters.

Filter cleaning

The sinter lamella filters are cyclically cleaned while the booth is in operation (jet cleaning). The cleaning system is initiated when the booth is started and remains enabled until the booth is switched off again.

The air for blasting off the filters is injected from the pressure tank via solenoid valves into the top section of the sinter lamella filters. The pressure tank and the solenoid valves are integrated in the ventilator housing.

The cleaning duration and the pause before the next filter pair is blasted off, is monitored by an electronic control circuit. The blasting time and the pause time are preset by the factory. However, these settings should be changed if the warning "pressure rise" responds frequently.

The cleaning process can be initiated manually for cleaning and control purposes.

Squeegee

The squeegee consists of two mechanically reinforced scrapers with rubber flaps that are arranged across the booth floor and which are interconnected at a specific distance (see diagram).

DIAGRAM OF A SQUEEGEE IN A BOOTH
EQUIPPED WITH FLUIDIZING
TROUGH

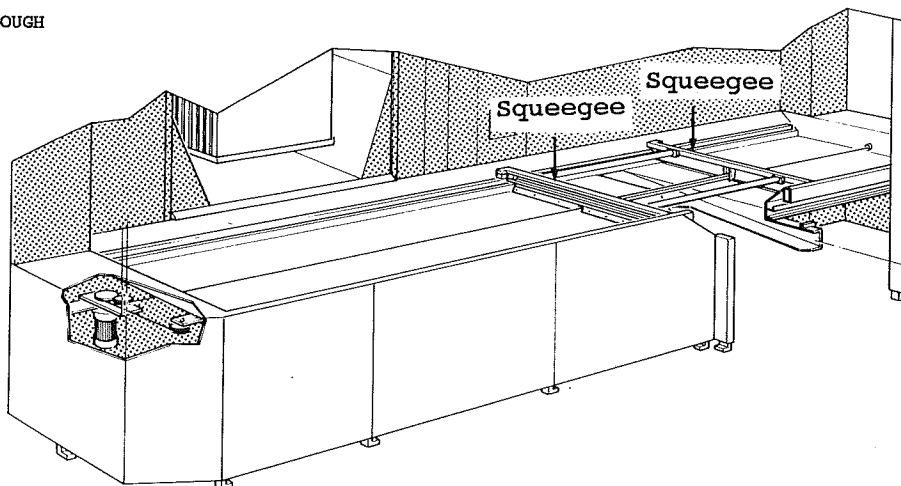

The squeegee is activated by the level sensor and stopped when the cycle is completed. A cycle comprises a forward and reverse motion up to the opposite end of the trough.

The rubber flaps move with minimal clearance over the booth floor and scrape the oversprayed powder into the fluidizing trough or the booth opening. The squeegee section that runs away from the center is lifted so that no powder is pushed against the end of the trough.

The squeegee is equipped with an electrically operated cable drive. During the squeegee cycle, the cable is rinsed with air at the inlet/outlet opening to the trough so that the powder adhering to the cable is blasted off.

Powder shortage

When the powder level drops below the upper level sensor of the powder truck, the blade is automatically activated at a predefined time. It scrapes the powder from the booth floor into the fluidizing trough, or through the booth opening, if a centrally arranged powder truck is configured. If the recovered powder is not sufficient for covering the level sensor, the virgin powder feed (option) is activated. In this case a predefined amount of powder is dumped on the booth floor so that it is again pushed into the recovery path by the squeegee. If the powder level sensor is still not covered, the powder level will drop below the lower sensor. When this happens, an alarm is triggered and a warning lamp is activated on the control panel to indicate a powder shortage (powder truck empty).

In booths not equipped with a virgin powder hopper (virgin powder system), the powder must be replenished manually.

Manual coating

Depending on the customer options, CRS booth may be equipped with a manual coating opening (10) in addition to the gun traversing slots. This opening can be used for manually precoating or touching up the workpieces.

Virgin powder hopper (option)

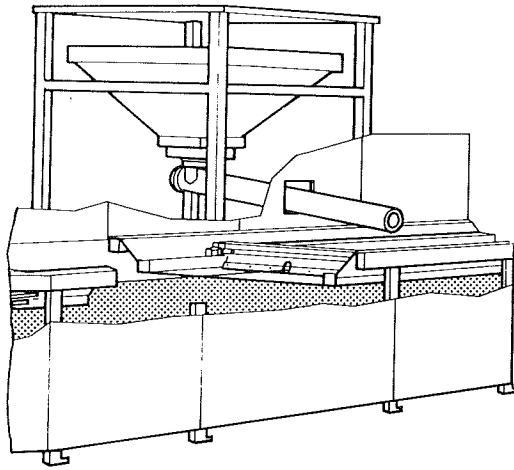

For automatic powder replenishment during operation, a virgin powder hopper is available for CRS booths. The powder in the hopper is fluidized and in the event of a powder shortage is fed automatically via a fluidizing tube to the booth floor or into a fluidizing canal.

When enamel powders are processed, a magnet separator is installed at the outlet of the fluidizing tube in order to eliminate metallic contaminants.

The powder level of the virgin-powder hopper is monitored. If the level drops below the sensor, a warning lamp lights up and an audible alarm is activated.

CRS BOOTH WITH FLUIDIZING CANAL AND INTEGRATED POWDER TRUCK

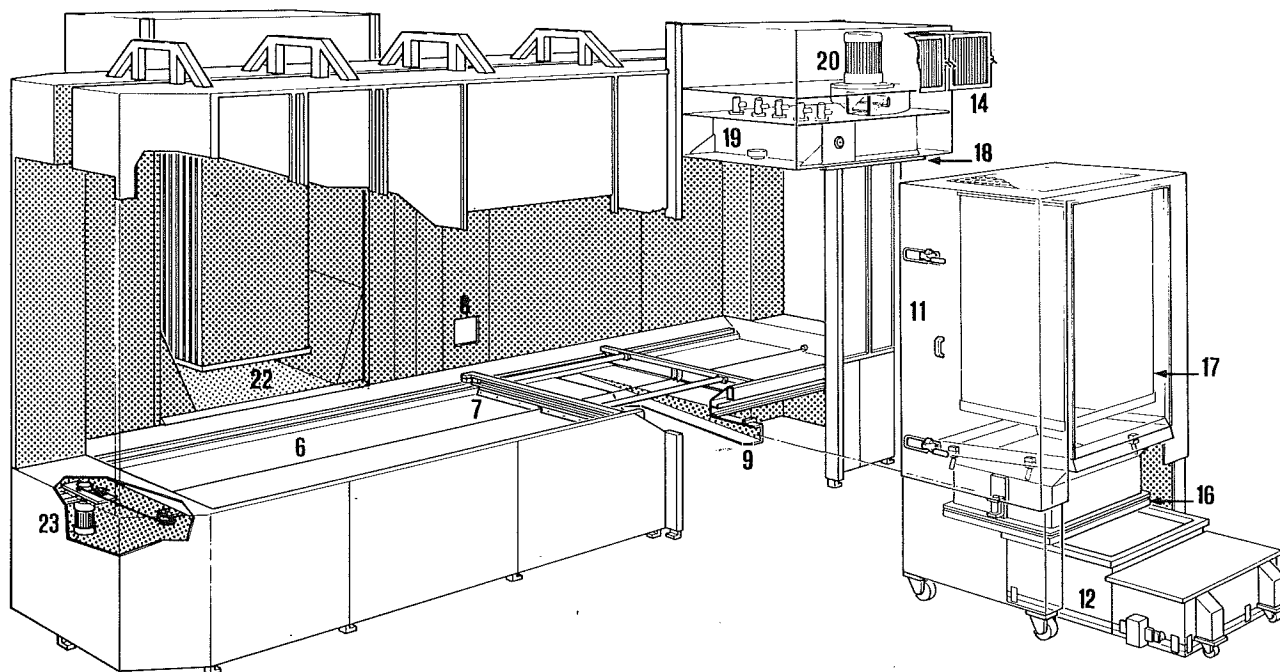

- | | |
|---|--------------------------------------|
| 6 Trough (booth floor) | 16 Sealing frame for powder truck |
| 7 Squeegee | 17 Sinter lamella filters |
| 8 Inlet for virgin powder | 18 Sealing frame for filter trolley |
| 9 Fluidizing trough | 19 Pressure tank for filter cleaning |
| 11 Filter trolley for integrating the powder truck | 20 Ventilator for exhaust air system |
| 12 Powder truck | 22 Filter truck with fluidized bed |
| 14 Clean-air filter elements (secondary filter) | 23 Squeegee drive |

In booths with fluidizing canal (9) the powder truck is arranged below the filter trolley. The powder pushed by the squeegee (7) into the fluidizing canal can flow out laterally and drops onto the oscillating screen of the powder truck below.

Filter trolley for coupling to the fluidizing canal

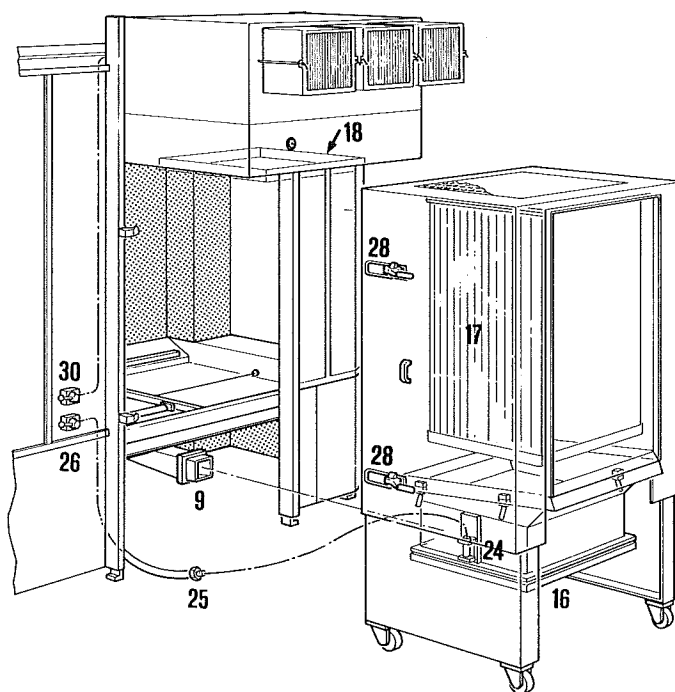

- 9 Fluidizing canal
- 16 Sealing frame for powder truck
- 17 Sinter lamella filters
- 18 Sealing frame for filter trolley
- 24 Pneumatic cylinder for drive to item 16
- 25 Pneumatic hose with quick-release coupling for item 16
- 26 ON/OFF valve for operating item 16
- 28 Toggle joint clamps
- 30 ON/OFF valve for operating item 18

FILTER TROLLEY FOR CONENCTION TO THE FLUIDIZING CANAL AND FOR INTEGRATING THE POWDER TRUCK

Filter trolleys for coupling to the fluidizing canal are open on the bottom and connected to the powder trolley via the perpendicular canal section (K). In the coupled position the fluidizing canal leads into the canal section so that the powder drops onto the oscillating screen of the powder truck below. The canal is sealed with a pneumatically positioned frame (16). This frame is lowered after the powder truck has been pushed into its position below the canal. A tight closure is thus achieved.

In the ceiling area, the filter trolley coupled to the booth with the pneumatically positioned frame (29) is connected airtight to the ventilator housing located above.

For filter trolleys with fluidizing bed refer to page 11.

Powder truck for integration below the filter trolley

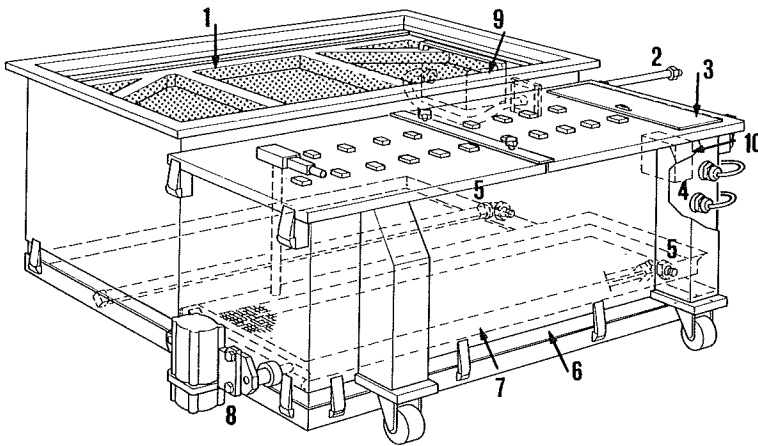

- 1 Vibrating sifter
- 2 Air inlet for vibrator
- 3 Inspection lid
- 4 Level sensor
- 5 Fluidizing air inlet
- 6 Fluidizing bed
- 7 Vibrating rake
- 8 Vibrator for rake
- 9 Vibrator for screen
- 10 Connection socket

POWDER TRUCK FOR INTEGRATED ARRANGEMENT

The powder truck can be rolled out on casters. The integrated powder truck is pressed pneumatically into the operating position.

During the coating operation, the powder in the truck is fluidized, i.e. the air injected from the bottom puts the powder into a fluid condition. The fluidization is supported by a built-in vibrating rake (7).

The powder supply is monitored by the level sensor (4). In the event of a powder shortage the level controller activates the squeegee and the virgin powder feed (option).

The powder on the booth floor and the virgin powder are returned from the top of the vibrating screen (1) into the powder truck. The screen eliminates any contaminants. The vibrator starts as soon as a squeegee cycle is initiated and continues to run for a preprogrammed time after the cycle has been completed. This after-running time can be adjusted.

CRS BOOTH WITHOUT FLUIDIZING CANAL, WITH CENTRAL POWDER TRUCK

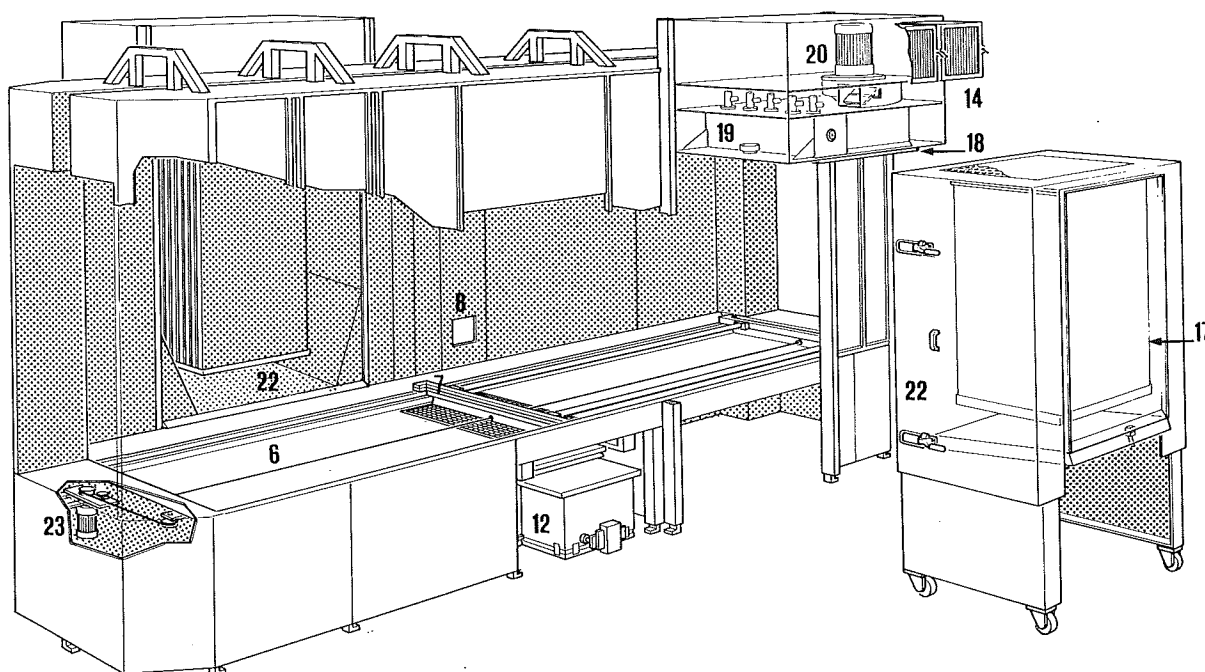

- | | |
|--|--------------------------------------|
| 6 Trough (booth floor) | 17 Sinter lamella filters |
| 7 Squeegee | 18 Sealing frame for filter trolley |
| 8 Opening for feeding virgin powder | 19 Pressure tank for filter cleaning |
| 12 Powder truck | 20 Ventilator for exhaust air system |
| 14 Clean-air filter elements (secondary filter) | 22 Filter truck with fluidizing bed |
| | 23 Squeegee drive |

In booths with central powder truck, the latter is arranged below the booth floor. No fluidizing canal is needed, the powder is pushed directly into the powder truck (12) through the trough opening above the sifter.

Filter truck for booths without fluidizing canal

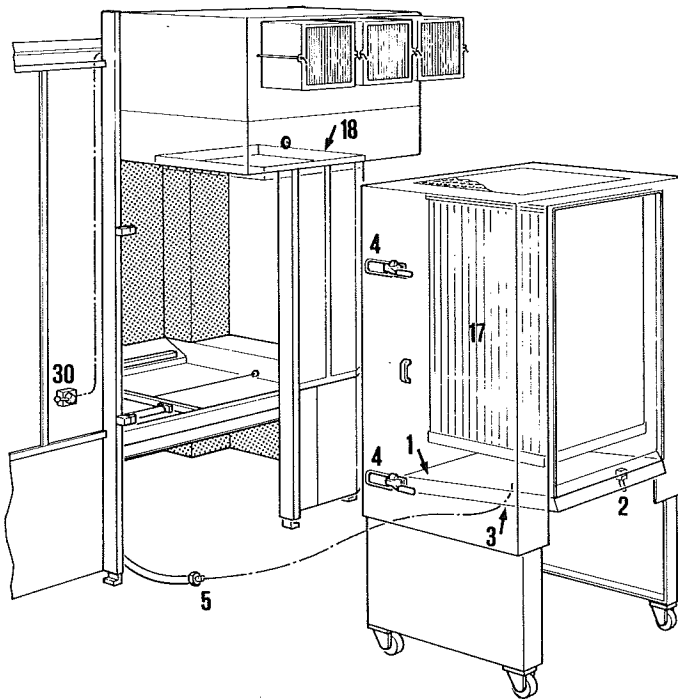

- 1 Fluidizing bed
- 2 Toggle joint clamps for lowering the fluidizing bed
- 3 Fluidizing air inlet for fluidizing bed
- 4 Toggle joint clamps
- 5 Air hose with quick-release coupling for fluidizing air
- 17 Sinter lamella filters
- 18 Sealing frame for filter trolley
- 30 OPEN/CLOSE valve for pneumatic drive of item 18

FILTER TROLLEY FOR BOOTHS WITHOUT FLUIDIZING CANAL

Filter trolleys for booths without fluidizing canal are terminated below the sinter lamella filters with a fluidizing bed. This fluidizing bed inclines toward the inside of the booth so that the dumped powder can flow toward the booth floor.

Filter trolleys with fluidizing bed are used for booths equipped with central powder truck or as a second truck for booths with integrated powder truck.

For information on how to connect the filter trolley to the fluidizing trough refer to page 8.

Powder truck for central arrangement below the booth floor

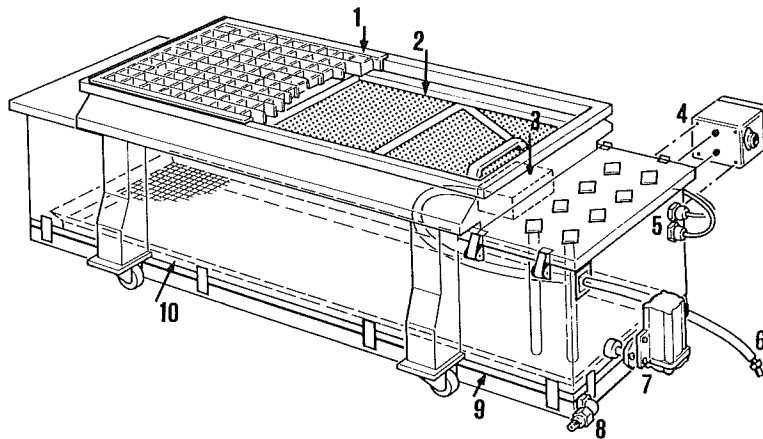

- 1 Grid
- 2 Vibrating screen
- 3 Vibrator for vibrating screen
- 4 Connecting socket for level controller
- 5 Level sensor
- 6 Air inlet for vibrator (3)
- 7 Vibrator for rake
- 8 Fluidizing air inlet
- 9 Fluidizing bed
- 10 Vibrating rake

POWDER TRUCK FOR CENTRAL ARRANGEMENT

The powder truck can be rolled out on casters. The centrally arranged powder truck is mechanically pressed into its working position (refer to Section "Installing the powder truck", page 14).

During the coating operation, the powder in the truck is fluidized, i.e. the air injected from the bottom puts the powder into a fluid condition. The fluidization is supported by a built-in vibrating rake (10). The injectors draw in the powder and convey it to the guns.

The powder supply is monitored by the built-in level sensor (5). In the event of a powder shortage the level controller activates the squeegee and the virgin powder feed (option).

The powder on the booth floor and the virgin powder are returned from the top of the vibrating screen (2) into the powder truck. The screen eliminates any contaminants. The vibrator starts as soon as a squeegee cycle is initiated and continues to run for a preprogrammed time after the cycle has been completed. This after-running time can be adjusted.

START-UP PREPARATIONS

Overview

- Refer to the safety recommendations (first page of this manual)
- Perform the following checks and the corresponding steps where applicable:
 - * Couple the filter truck (see next Section)
 - * Install the powder truck / recovery container (see page 14)
 - * Fill in the powder (see pages 16 and 17)
 - * Replenish the powder, if necessary (see pages 23 and 24)
 - * Check the cable tension and the snap closures on the squeegee linkage; the closures should be fastened and the cable should be taut (squeegee, see page 15)
 - * Check that the sinter lamella filters are properly seated

Coupling the filter truck

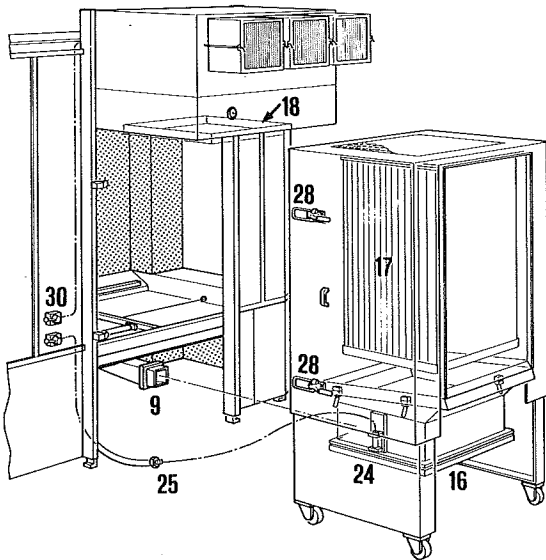

Procedure

(Same procedure as for the filter trolley for integrating the powder truck, and for filter trolley with fluidizing bed)

- Set valve (30) (see foldout page) to the OPEN position (the sealing frame (18) will be lifted)
 - Roll the filter truck to the booth opening
 - Couple the pneumatic hose (25) (for a filter trolley with fluidizing bed this is a fluidizing tube)
 - Slide the filter truck against the booth wall
 - Laterally engage the toggle clamps (28) and tighten them
- Set valve (30) to the CLOSED position: the frame (18) is lowered over the filter trolley and pressed down (the filter trolley is now connected airtight to the ventilator housing)

Installing the powder truck below the filter trolley

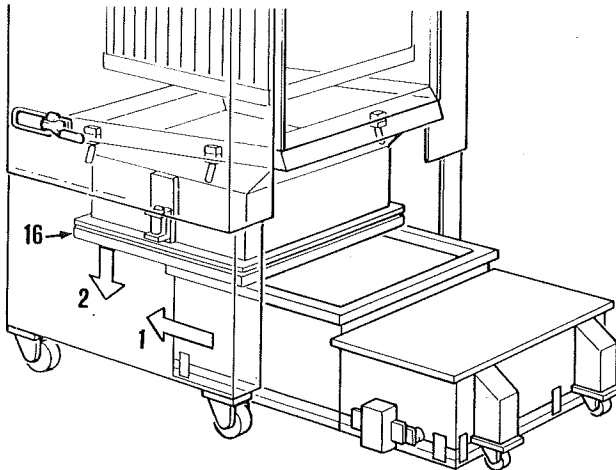

1 = Slide powder truck
under the filter
trolley

2 = Lower the sealing
frame

Procedure

- Set valve (26) to the OPEN position (the sealing frame (16) is raised)
- Slide the powder truck under the filter trolley all the way to the stop position
- Set valve (26) to the CLOSED position: the frame (16) is lowered over the powder truck opening and pressed down; the powder truck is now connected airtight to the filter trolley.
- Connect the air hoses for the fluidization and the vibrating screen
- Connect the level control cable
- Connect the vibrator for the vibrating rake
- Connect the injectors

Installing the powder truck below the booth floor

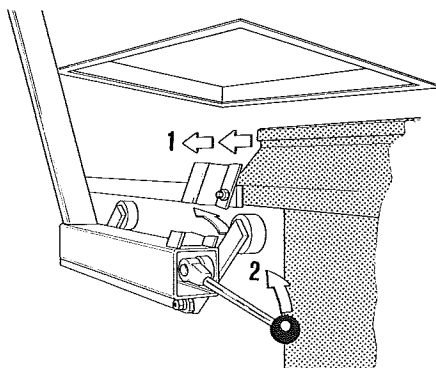

1 = Slide powder truck under
the booth floor

2 = Lift the powder truck

Procedure

- Slide the powder truck under the booth floor all the way to the stop position (arrow 1)
- Lift lever (H) (arrow 2), first on the left and then on the right
- Connect the air hoses for the fluidization and the vibrating screen
- Connect the level control cable
- Connect the vibrator for the rake
- Connect the injectors

Note: Make sure the powder truck does not drop down when you lower it!

Checking the squeegee in booths with or without fluidizing canal

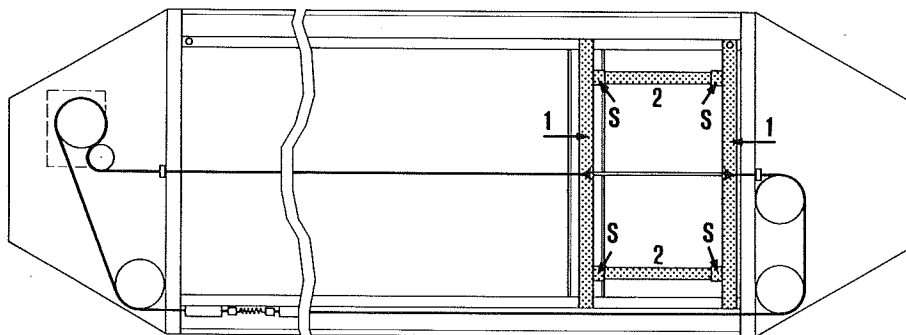

SQUEEGEE FOR BOTH WITH FLUIDIZING CANAL

- 1 Squeegee rake
- 2 Squeegee linkage

The squeegee consists of the two rakes (1) and the linkage (2). It can be removed and lifted off after the two quick-release clamps (S) have been unfastened. This applies to squeegees of booths with or without fluidizing canal. (Both squeegees have the same design).

When the booth is put into service, check that the quick-release clamps (S) (see diagram) are properly seated. The cable should be taut.

Filling the empty powder truck

The following Section describes how the empty powder truck is to be filled. For replenishing powder during the coating operation refer to page 23.

In order to eliminate contaminants from the powder, the virgin powder should not be filled directly into the powder truck.

Manual filling procedure

- First give the booth a rough cleaning, if necessary (see page 26)
- Enable the compressed-air network and check the inlet pressure on the gauge (11) (nominal value: 7 bar)
- Switch on the booth (also refer to "Quick-reference instructions" on the front foldout page): Set the master switch Q0 to the ON position, actuate the keylock switch S01.
- Actuate switch S4 (booth cleaning): the squeegee performs one cycle
- Dump approx. 10 kg of powder in front of the squeegee and distribute the powder across the full width of the trough
- Actuate switch S10 (squeegee, manual): The powder is pushed over the filter screen of the powder truck and filtered so that it is free from contaminants
- If necessary actuate the squeegee again until all powder has been pushed into the trough; add additional powder until the required amount has been filled (no more than approx. 15 kg per filling cycle)
- Turn switch S4 to the OFF position

The recommended filling quantities are listed on the next page.

Filling quantities with empty powder truck (average values)

| Powder truck arrangement | Booth width 14 dm | Booth width 18 dm | Powder type | No. of injectors |
|--------------------------|-------------------|-------------------|-------------|------------------|
| Integrated | 94 kg | 94 kg | Enamel | 8 |
| Central | 94 kg | 122 kg | Enamel | 8 |
| Central | 110 kg | 137 kg | Enamel | 16 |
| Integrated | 60 kg | 60 kg | Plastic | 8 |
| Central | 60 kg | 76 kg | Plastic | 8 |
| Central | 70 kg | 86 kg | Plastic | 16 |

The specified filling quantities are average values of different powder types and should be regarded as approximate values for filling an empty powder truck.

Do not overfill the powder truck!

If the recommended filling quantities are not strictly adhered to, the powder truck may overflow (the powder volume increases due to fluidization).

Automatic filling of the powder truck

(only possible for booths with virgin powder hopper)

In booths equipped with a virgin powder hopper (see page 6), the powder is fed via a fluidizing tube to the virgin powder hopper.

The replenishing operation is automatically initiated when the powder truck is empty which means that it suffices to switch on the system for filling the powder truck.

Before switching on the booth:

- Give the booth a rough cleaning, if necessary (see page 26)
- Switch off the alarm (switch S5)
- Switch on the virgin powder hopper (switch S7) (pilot lamp H12 is on)

Filling procedure:

- The squeegee performs a cycle; any remaining powder will be pushed into the fluidizing canal or the powder truck.

- The virgin powder feed is activated. Powder is fed via the fluidizing tube until the feed time is expired.
- The squeegee performs another cycle

The replenishing operation is repeated until the level sensor in the powder truck is covered with powder (pilot lamp H6 "Powder hopper full" lights up).

After the filling operation:

Return switch S5 (alarm) to the ON position.

START-UP PROCEDURE

Switching on the booth

- Enable the compressed-air network and check the inlet pressure on the pressure gauge (11), nominal value 7 bar
- Switch on the booth (see also "Quick-reference guide" on the front foldout page): Turn the master switch Q0 and the keylock switch to the ON position, briefly press button S2

Setting the operating parameters on the pneumatic panel

PNEUMATIC PANEL

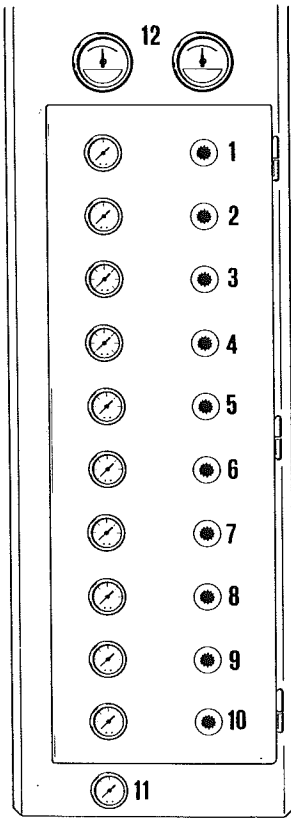

| | | | | |
|----|----|-----------------------------------|-----------------|------------|
| ** | 1 | Virgin powder hopper | 2.0 | bar |
| | 2 | Virgin powder tube | 1.0 | bar |
| | 3 | Fluidizing trough | 2.0 | bar |
| | 4 | Fluidizing bed | 2.0 | bar |
| | 5 | Connecting frame for filter truck | 2.0 | bar |
| | 6 | Pressure tank | 5.5 | bar |
| | 7 | Cable rinsing | 2.0 | bar |
| | 8 | Screen | 2 to 3.5 | bar |
| ** | 9 | Continuous fluidization | 0.5 to 1.5 | bar |
| ** | 10 | Prefluidization | 3 to 5 | bar |
| | 11 | Compressed air inlet | min 6 opt. 7 | bar bar |

**) Depending on powder type

Concerning item 6: This pressure should not be set higher
 Concerning item 9: The powder should "boil" lightly (can be checked through the inspection lid in the powder truck)

Adjusting the powder fluidization

The fluidization of the powder is performed in two phases.

In the first phase, the prefluidization, the powder is intermixed during approx. 40 seconds by strong air blasts and thus prepared for continuous fluidization.

In the second phase, the continuous fluidization, an air stream flows continuously from the bottom through the powder so that it is maintained in a fluid-like condition (the powder boils lightly). With the start of the second phase the system is ready for operation. The changeover from the first to the second phase is performed automatically.

The adjustment of the required air pressures for prefluidization and continuous fluidization depends on the type of powder, the air humidity, and the ambient temperature. For this reason only a preliminary adjustment of the fluidization is possible (the recommended values for the compressed-air parameters can be found in the last Section). The parameters are to be readjusted based on experience values with the powder to be processed, or based on the inspection of the powder level during the various phases (inspection lid in the powder truck).

Fluidization parameters:

- Air pressure for the prefluidization (adjustable on the pneumatic panel)
- Air pressure for continuous fluidization (adjustable on the pneumatic panel)
- Time parameters for the duration of the air blasts in the prefluidization phase and the total duration of this phase (adjustable in the control cabinet, see next Section).

Adjusting / readjusting the time parameters for the

 prefluidization

CONFIGURATION DIAGRAM, CONTROL CABINET

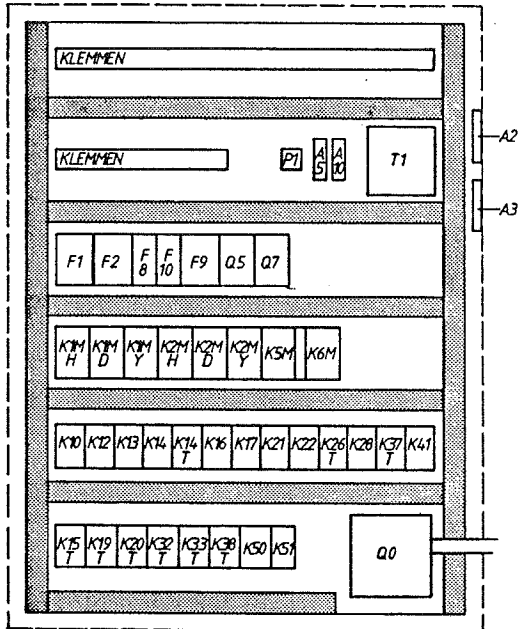

- Shut down the booth
- Open the control cabinet, adjust relay K50 (see opposite configuration diagram of the control cabinet)
- Close the control cabinet and put the booth into operation
- Check the fluidization in the powder truck (by opening the inspection lid)
- Shut down the booth again and readjust the settings, if necessary

TIME RELAY

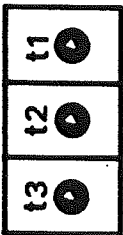

| Pot.meter | Function | Approx. value |
|-----------|--|---------------|
| t1 | Time adjustment for the duration of the air interval | 0.3 s |
| t2 | Time adjustment for the pause duration | 0.4 s |
| t3 | Time adjustment for the duration of the entire prefluidization phase | 40 s |

OPERATION
-----**Checks before the booth is switched on**

- Functional checks:** A functional check may possibly have to be performed (see page 35) before the coating operation is started
- Ground connection:** Check the ground connection of the booth and the other system components. Make any necessary corrections.
- Performing the start-up procedure:** The start-up procedure should be performed after prolonged idle times (see page 19)
- Safety recommendations:** The safety recommendations given on the first page of this manual should be strictly followed.

Switching on the booth

- Turn the master switch Q0 to the ON position (the master switch is located on the control cabinet)
- Turn keylock switch S01 ON: the control system is now enabled, lamp H0 lights up, the keylock switch returns to the initial position
- Press push button S2: The ventilator(s) ramp up; upon completion of the acceleration phase:
 - * Lamp H1 lights up
 - * The prefluidization in the powder truck is started together with the vibrating rake
 - * The cleaning cycle of the sinter lamella filter is activated

Upon completion of the prefluidization phase, continuous fluidization is activated, the powder level control is enabled, and the interlocked system components are enabled (ES control equipment, etc.)

- Check the continuous fluidization through the inspection lid in the powder truck; the powder should "boil" lightly, if necessary readjust valve (9) on the pneumatic panel
- Switch on the ES equipment: the guns start to spray

Switching off the booth

- Switch off the ES equipment and all ancillary system components
- Press button S1: lamp H1 switches off, all interlocked system components are blocked
- Turn master switch Q0 to the OFF position: lamp H0 switches off
- Check the screen of the powder truck for contaminations and clean it, if necessary

Filter cleaning

The filter lamella filters are cleaned cyclically during the coating operation. The cycle times are preset by the factory. If the max. differential pressure is exceeded repeatedly (an alarm has been triggered), check that the sinter lamella filters are correctly seated and that there are no leaks in the gasket (refer to TROUBLESHOOTING GUIDE, page 37).

The differential pressure is indicated by the pressure gauge (12). The upper limit at which an alarm is triggered is 240 mm HH.

The adjustment of the cycle time is described in the circuit diagram.

Powder recovery

When the powder level in the powder truck drops below the upper level sensor, a squeegee cycle is initiated and the remaining powder is transported to the powder truck either directly or via the fluidizing canal, depending on the booth version. The sifting vibrator in the powder truck starts concurrently with the squeegee so that any contaminants are removed from the remaining powder.

If the recycled powder is insufficient to cover the upper level sensor, the powder level will after a while drop below the lower level sensor. At this point an audible alarm is actuated and the powder shortage is signalled by lamp H5. (For booths equipped with a virgin powder hopper refer to next section).

Replenishing with virgin powder
-----**Manual**

- Switch off the alarm (switch S5): the lamp H10 lights up.
- If possible give the booth a rough cleaning (see page 26)
- Dump approx. 10 kg of powder in front of the squeegee and distribute the powder across the full width.
- Press button S10 (squeegee, manual) and wait until the sifting process is completed.
- Repeat this procedure until the entire sack (approx. 25) of powder has been added.
- Turn switch S5 (alarm) to the ON position.

Automatic (only with virgin powder hopper)

When the system is equipped with an integrated virgin powder hopper (see page 6), the filling process is automatically initiated in the event of a powder shortage. If upon completion of the process an alarm is triggered because of a powder shortage (pilot lamp H5 is on), the filling time should be checked and possibly adjusted (with the corresponding timing relay, see circuit diagram). This work should only be performed by a skilled person.

MAINTENANCE

Maintenance schedule

| Time interval | Steps to be performed |
|---------------------------|--|
| Daily or after each shift | <ul style="list-style-type: none"> - Blow out the powder hoses - Clean the outside of the guns and check the wearing parts - Perform coarse booth cleaning (see "Coarse booth cleaning", page 26) - Check the sifter screen in the powder truck and remove any contaminants by means of an industrial vacuum cleaner |
| Weekly | <ul style="list-style-type: none"> - Check the clean-air filter cells at the ventilator housing for powder deposits; if powder is present this means that there is a leak in the gasket of the sinter lamella filters; check that the filter is correctly seated (instructions for replacing the clean-air filter can be found on page 30, new sinter lamella filter gaskets can be ordered according to the spare parts list). - Clean the booth completely (no wet cleaning!) Important: booth cleaning should not be performed immediately after the powder truck has been refilled with virgin powder because the powder could possibly overflow! - Empty the powder truck and clean it (see page 27) - Check the oil separator and empty it, if necessary (if oil is present, check the air dressing plant) |
| Semianually | <ul style="list-style-type: none"> - Disconnect the measuring lines to the manostats at the pressure gauge (12) and blow them out in the direction from the pressure gauge to the measuring point (start of line) (line color code: red = high, blue = low) Important: It is important to blow out the lines in the specified direction! |
| Annually | <ul style="list-style-type: none"> - Change the transmission oil of the squeegee drive; oil grade: SAE 50 |

Note: All components to be replaced as part of the maintenance

DOCUMENTATION CRS-L/CRS-E

are available as spare parts. Please refer to the spare parts list.

Rough booth cleaning

Caution: Overfilling hazard!

Rough cleaning of the booth should not be performed immediately after the powder truck has been filled / refilled. In addition the virgin powder hopper should be switched off some time before the cleaning so that the powder level drops.

Procedure

- Switch on the booth
- Check the sifter screen of the powder truck and remove any contaminants with the aid of an industrial vacuum cleaner
- Tap the booth walls from the outside so that the powder adhering to the walls drops off
- Activate the squeegee (push button S10); the sifter screen starts to vibrate. The remaining powder is pushed off

Important: Never clean the sinter lamella filters with a scraper or any hard objects!

Booth cleaning

Caution: Overfilling hazard!

Booth cleaning should not be performed immediately after the powder truck has been filled / refilled. In addition the virgin powder hopper should be switched off some time before the cleaning so that the powder level drops.

Procedure

- Switch on the booth and wait until all sinter lamella filters have been cleaned off
- Actuate switch S4 (booth cleaning): the filter cleaning, the fluidization and all other interlocked system components switch off. The booth can now be entered.
- Check the sifter screen of the powder truck and remove any contaminants by means of an industrial vacuum cleaner
- Clean the booth walls with a rubber scraper
- Make sure that all persons have left the booth before you press button S10 (squeegee, manual), the powder is pushed off
- Remove the squeegee and clean it (proceed as described below)

- Clean the booth floor
- Roll out the powder truck and clean it (proceed as described below)
- Reinstall the squeegee
- Reinstall the powder truck and reestablish all connections

Important: Never clean the sinter lamella filters with a scraper or any hard objects!

Procedure for removing the squeegee

- 1 Squeegee rake
- 2 Squeegee linkage
- 3 Drive cable
- 4 Control linkage
- 5 Sliding rails
- 6 Induction signal emitter (limit switch)
- 7 Drive
- 8 Cable rinsing

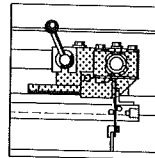

View of item 1

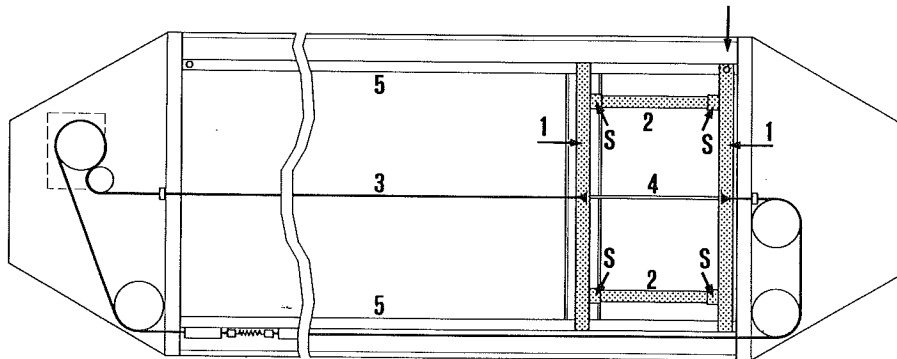

DIAGRAM OF A SQUEEGEE IN A BOOTH WITH FLUIDIZING CANAL

- Switch off the booth and remove the key from the lock S01
- Release the quick-release couplings or screws (S) and lift out the squeegee linkage
- Lift out both squeegees (control linkage with cable remains taut)

Cleaning the powder truck

- Start the booth, make sure that no person has remained inside the booth, and press button S10 (squeegee, manual) (these steps have already been performed for the booth cleaning)
- Wait until the after-running time of the screen has expired, then switch off the booth
- Roll out the powder truck and consult the instructions in the Section "Installing the powder truck" (page 14). Note: Do not separate the hose connections to the injectors. If the hose length is not sufficient, perform the next step before you roll out the powder truck
- Remove the injector plate (1), clean it, and set it aside
Important: Do not unfasten the hose connections at the injectors
- Remove the sifter screen (2) and set it next to the truck
Important: Do not unfasten the air connection (3) to the vibrator. Pull out a sufficient length of hose so that the screen can be set on the floor!
- Only now disconnect base from the vibrating sifter. Check the screen for damage and replace it, if necessary
- Check the rubber section of the screen frame seat and check the oscillating elements, replace them if necessary
- Check the rubber section of the injector plate seat and replace it, if necessary
- Use a rubber scraper to wipe the powder off the inside walls of the powder truck
- Reassemble the powder truck, install it, and reestablish all connections

- 1 Injector plate
- 2 Vibrating sifter
- 3 Air inlet for vibrator

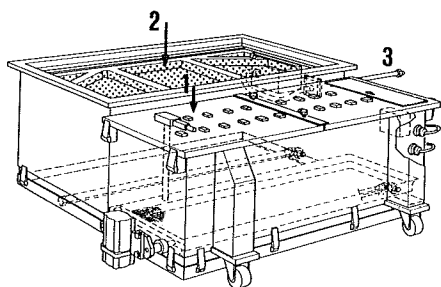

POWDER TRUCK FOR INSTALLATION BELOW
THE FILTER TRUCK

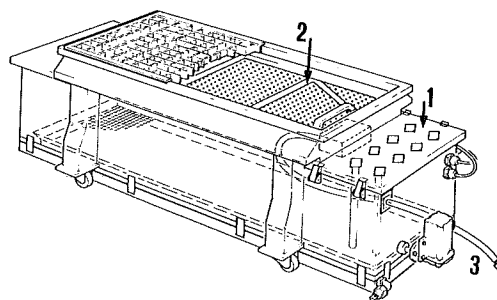

POWDER TRUCK FOR CENTRAL ARRANGEMENT

REPLACEMENT OF SPARE PARTS

General

**Parts should be replaced only by trained specialists!
The system must be shut down before any parts are replaced!**

Please order all spare parts in accordance with the spare parts list.

Replacing the bulbs for push buttons and signal lamps ----- on the control cabinet -----

Push buttons

- Unscrew the protective ring (R)
- Remove the plastic cap (K) by pulling it toward the front
- Pull off the white internal cap (I); caution: sealing ring
- Replace the bulb with the aid of a bulb extractor and reassemble the push button.

Signal lamp

- Unscrew the plastic cap (K)
- Remove the white cap (I) with the sealing ring and replace the bulb with the aid of the lamp extractor

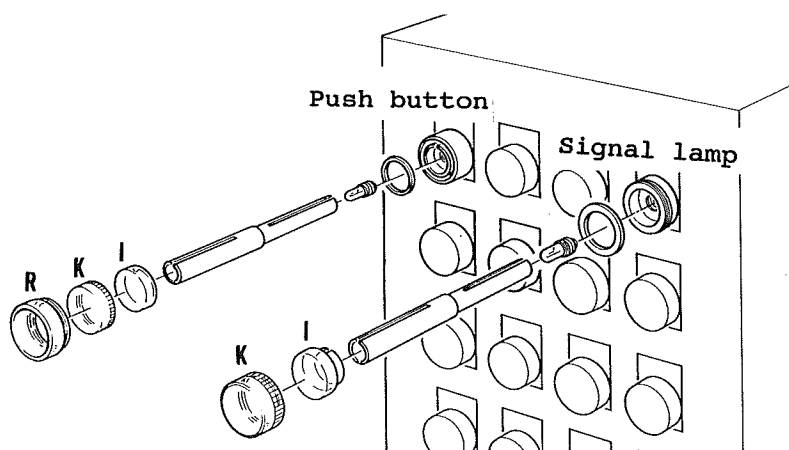

CONTROL CABINET WITH PUSH BUTTONS AND SIGNAL LAMPS

Replacing the clean-air filter elements

The clean-air filter elements of booths without silencer hood are replaced in the same way as in booths with silencer hood (see diagram). The only difference is in the arrangement of the clean-air filter cells (they are located on the roof of the ventilator housing).

- Unfasten the quick-release coupling (1) and turn the locking shackle downward (see diagram)
- Lift off the filter elements
- Check the inside of the clean-air chamber for any powder deposits and clean the chamber, if necessary
- Install new filter element

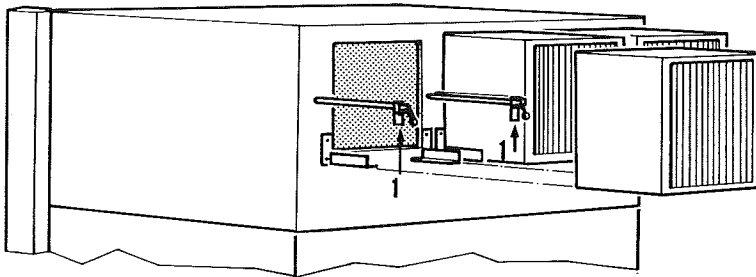

REPLACING THE CLEAN-AIR FILTER ELEMENT

Replacing the pressure control valve on the pneumatic panel

- Vent the compressed-air network of the booth: for this purpose close the inlet pressure regulator and put the booth into operation until all compressed air of the pressure tank in the ventilator housing has been consumed; the pressure gauge 6) (pneumatic panel) and the pressure gauge of the pressure tank (on the ventilator housing) indicate 0
- Switch off the booth
- Open the pneumatic panel
- Disconnect the measuring hose to the pressure gauge of the valve to be replaced (slide ring (R) against the ventilator housing)
- Unscrew the socket plate (B) (gasket)

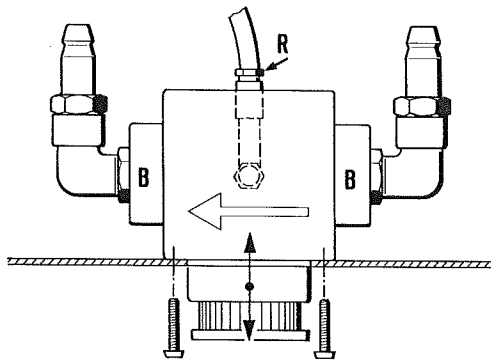

- Turn out the fixing screws while supporting the valve body with your hand.
- Remove the valve and install a new one (two tapped holes on the ventilator housing serve as mounting holes)
- Install the socket plate with the gasket
- Readjust the compressed-air system and check that the hose connections are not leaking

VALVE

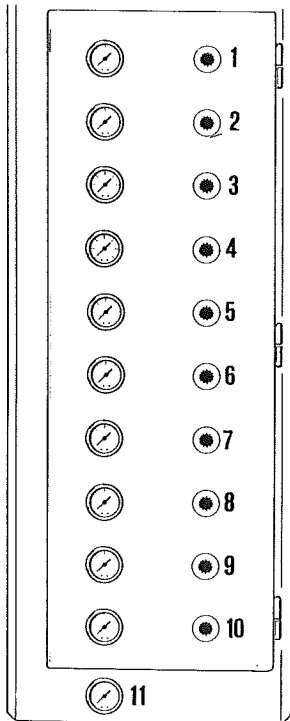

- 1 Virgin powder hopper
- 2 Virgin powder tube
- 3 Fluidizing canal
- 4 Fluidizing canal
- 5 Connecting frame
- 6 Pressure tank
- 7 Cable rinsing
- 8 Screen
- 9 Continuous fluidization
- 10 Prefluidization
- 11 Compressed-air inlet

PNEUMATIC PANEL

Replacing the solenoid valve for filter cleaning

The solenoid valves for jet cleaning are located in the ventilator housing (see diagram) and become accessible after the secondary filter elements have been removed. If a solenoid valve is defective, it usually suffices to replace the visible top part that houses the diaphragm.

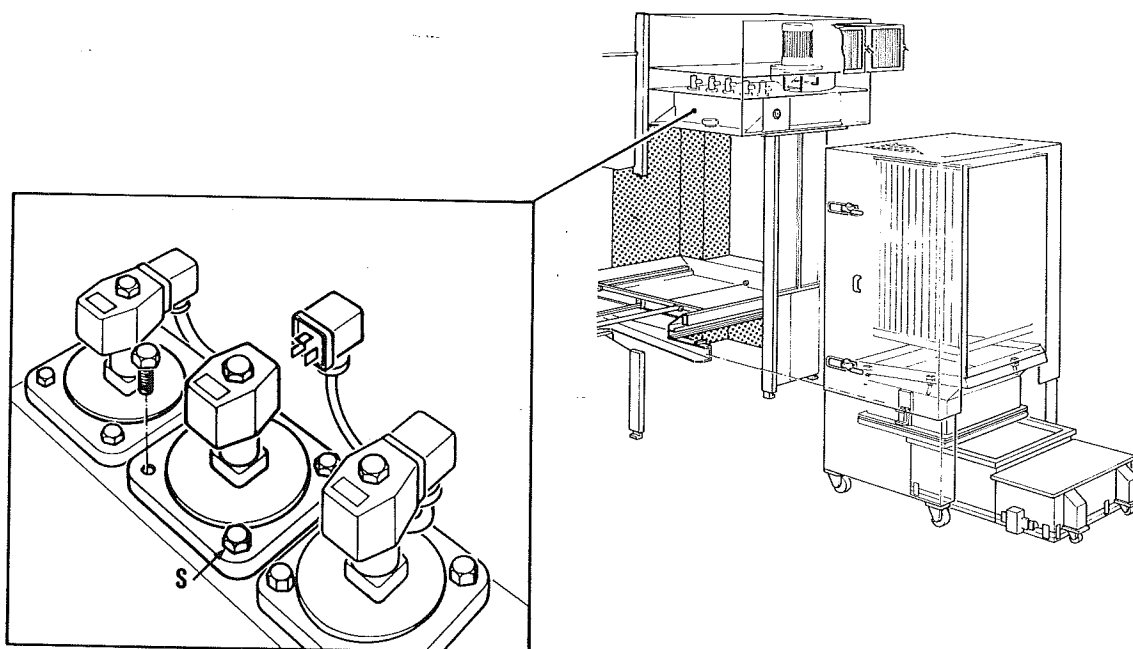

SOLENOID VALVE FOR JET CLEANING

Procedure

- Vent the compressed-air network of the booth: for this purpose close the inlet pressure regulator and put the booth into operation until all compressed air of the pressure tank in the ventilator housing has been consumed; the pressure gauge 6) (pneumatic panel) and the pressure gauge of the pressure tank (on the ventilator housing) indicate 0
- Switch off the booth
- Remove the clean-air filter elements (see page 30); the solenoid valves are now accessible through the filter element opening
- Pull off the control cable to the defective solenoid valve
- Turn out screws (S), lift off the top section of the solenoid valve and replace it (caution: gasket)

Replacing the pressure gauge

The pressure gauge(s) and the corresponding manostat(s) for monitoring the sinter lamella filter pressure are located above the pneumatic panel (refer to foldout page, pressure monitoring (4)).

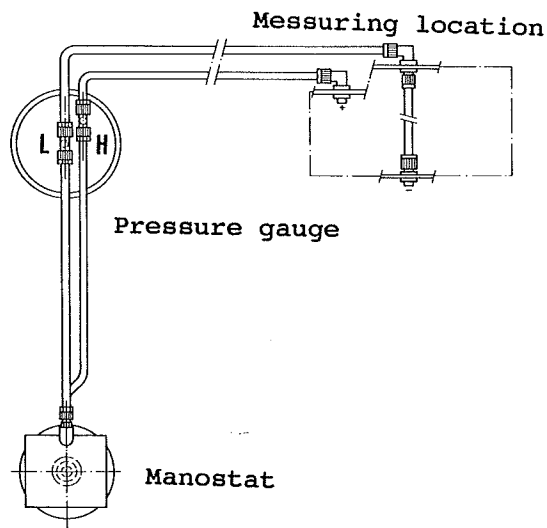

CONNECTION DIAGRAM FOR PRESSURE GAUGE AND MANOSTAT

- Switch off the booth
- Open the pneumatic panel
- Separate the pressure gauge connections and label them
- Remove the pressure gauge
- Blow out the air hoses in the direction of the measuring location
- Install a new pressure gauge and connect it in accordance with the diagram above (H = high, red hose), L = low, blue hose)

Replacing the squeegee traction cable

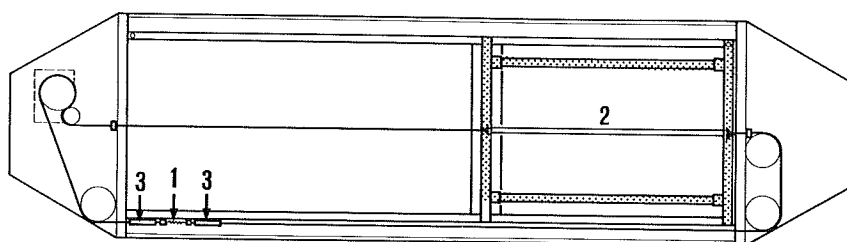

SQUEEGEE FOR BOOTH VERSIONS
WITH FLUIDIZING CANAL

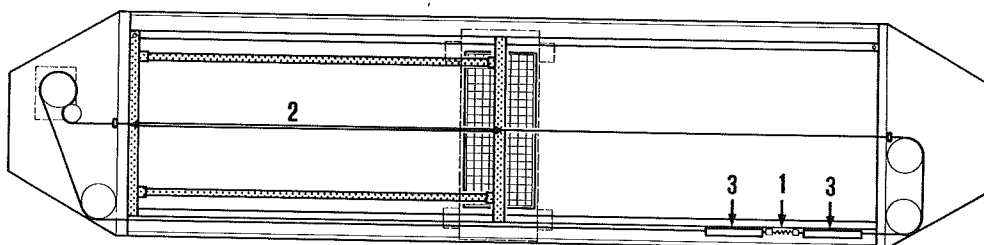

SQUEEGEE FOR BOOTH VERSIONS
WITH CENTRAL POWDER TRUCK

- Remove the cover panel at the cable tensioner (1), see diagram
- Remove the old cable
- Insert the new cable at the control linkage (2)
- Push the squeegee against that end of the trough that is opposite the cable tensioner
- Run the cable around the guide roller as illustrated and install the thimble in such a way the tensioning device is located between the protective tubes (3)
- Tension the cable; the spring must be extended by at least 100 mm; if this is not possible, shorten the cable

FUNCTIONAL CHECK

Performing the functional check

A functional check should be performed:

- After the replacement of spare parts on the booth and on the electrical section of the booth or system components connected to the booth
- After manipulations on the electrical section or on the control of external system components connected to the booth control or on the booth control itself have been performed
- After prolonged idle periods

Preconditions for performing the functional check

- Powder truck empty or powder level below sensor
- Switch S5 (alarm): ON
- Switch S7 (virgin powder hopper): OFF

Procedure

- Turn on the master switch (Q0): It should not be possible to start the ES control units and any interlocked system components
 - Turn on the keylock switch (S01): Lamp (H0) should light up. It should not be possible to start the ES control unit and any interlocked system components
 - Press button (S2): The exhaust air ventilator(s) should start. After the acceleration phase:
 - * Lamp (H1) should be light
 - * Prefluidization and the rake in the powder truck should start
 - * The cleaning cycle for the sinter lamella filter should start
- After approx. 40 seconds:
- * The prefluidization should change to continuous fluidization
 - * The ES control unit and all interlocked system components should be ready for operation
 - * The level controller starts: Lamp (H4) (powder below minimum level) lights up (because powder truck is empty), the squeegee should start and perform a cycle: The sifter should also start and the squeegee should perform another cycle.
 - * After lamp H4 (powder below minimum level) lights up, lamp H5 should also switch on with a delay and an alarm should be triggered (powder truck empty); delay time: approx. 6 min

TROUBLESHOOTING GUIDE

IMPORTANT

Malfunctions in the electrical section should be remedied only by qualified technicians!

| Fault / Error / Problem | Remedial action |
|---|--|
| <p>Alarm has been activated lamp H5 is light</p> <p>Powder shortage in powder truck</p> | <p>Disable the alarm with switch S5, add virgin powder (see page 23), and reenale the alarm</p> |
| <p>Alarm has been activated, lamp H7 is light</p> <p>Squeegee malfunction, the squeegee cannot return to the starting position</p> | <p>Switch off master switch Q0, check the powder trough and remove any foreign objects that may possibly block the squeegee, start the booth, the squeegee moves to the starting position</p> |
| <p>Alarm has been activated lamps H7 and H9 are light</p> <p>Squeegee motor defect, corresponding motor protection switch has responded</p> | <p>Switch off master switch Q0, allow the motor to cool off, reactivate the corresponding motor protection switch (see circuit diagram) and restart the booth; if this fault occurs repeatedly, consult your RANSBURG agency</p> |
| <p>System has shut down, Lamp H9 is light</p> <p>Ventilation motor(s) defective</p> | <p>See preceding problem</p> |

| Fault / Error / Problem | Remedial action |
|--|--|
| <p>Alarm has been activated, lamp H8 is light</p> <p>Pressure rise in exhaust system</p> | <p>Pressure rise in the exhaust air system. Disable the alarm switch S5. Switch off all external system componente such as ES equipment, etc. Wait until the cleaning cycle has been completed Check the differential pressure; if it too high, check the sinter lamella filters for leaks (the filter plates are clogged on the inside by the penetrating powder) Replace the gaskets, if necessary Clean or replace the secondary filter cells</p> |
| <p>OPTION Alarm has been activated Lamp H13 is light</p> <p>Virgin powder hopper empty</p> | <p>(only with virgin powder hopper)</p> <p>Add virgin powder</p> |

TECHNICAL DATA (subject to change)
-----**Power requirements**

Voltage: 3 x 380 V / 50 Hz
Other voltages and frequencies
on request

Ventilator power per filter truck

4.0 kW with 4 filter plates (1 ventilator)
5.5 to 11 kW with 6 to 14 filter plates (1 ventilator,
ventilator housing
with silencer hood)

Squeegee motor power: 0.25 kW

Booth differential pressure: max. 240 mm HH

Compressed-air connection

Inlet pressure: min. 6 bar/max. 12 bar

Recommended inlet pressure: 7 bar

Water vapor content: max. 1.3 g/m³

Oil content: max. 0.1 ppm

Compressed-air consumption

Rinsing air per filter truck: max. 18 Nm³ /h

Prefluidization with
integrated powder truck: approx. 43 Nm³ /h

Prefluidization with
central powder truck: approx. 60 Nm³ /h

Vibrating sifter: approx. 15 Nm³ /h

Squeegee cable rinsing: approx. 9 Nm³ /h

Fluidization in virgin
powder hopper: approx. 20 Nm³ /h

Product code

CRS - EI 14.1 - 6.14 - 200

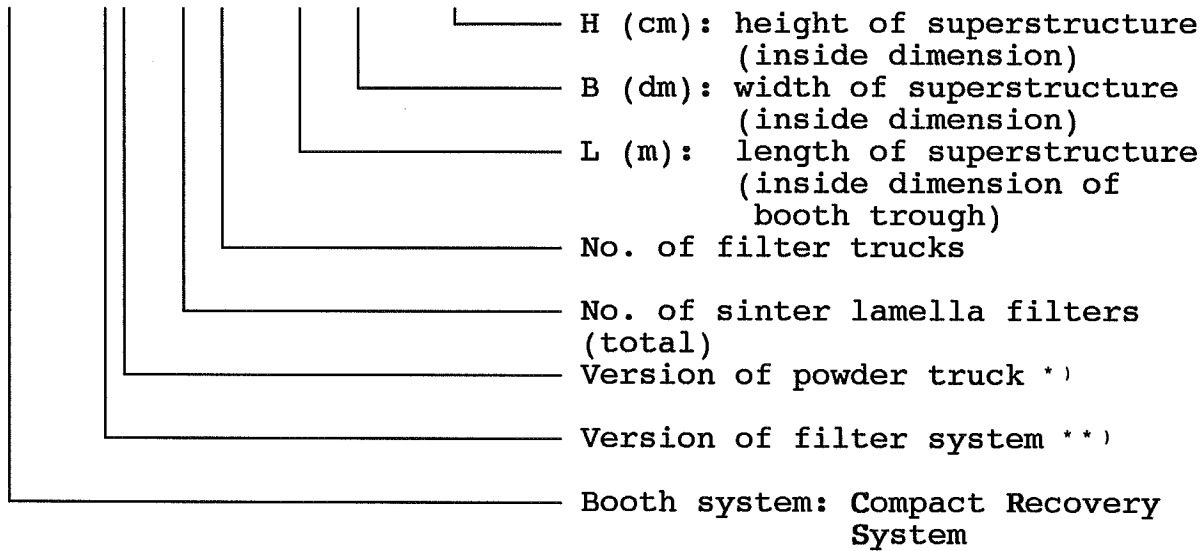

**) Version of filter system:

C = Cartridge filters

L = Sinter lamella filters for organic powder

E = Sinter lamella filters for enamel powder

*) Version of powder truck:

I = Integrated powder truck (with squeegee and fluidizing canal)

Z = Central powder truck (with squeegee, without fluidizing canal)

F = Fluidizing canal (centrally arranged, with squeegee)

OPERATOR CONTROLS

Control cabinet

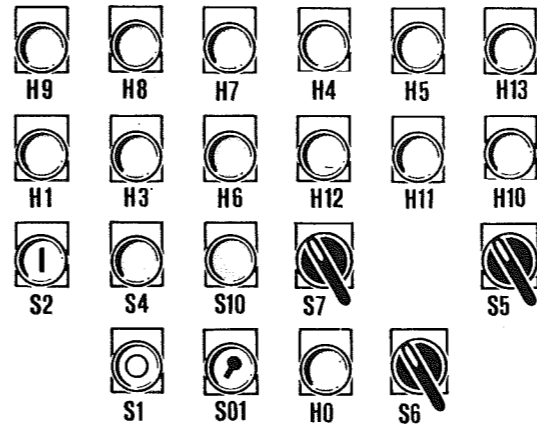

H = Pilot lamp

S = Switch
Push button

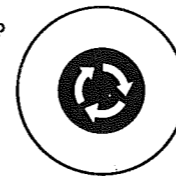

Pneumatic panel

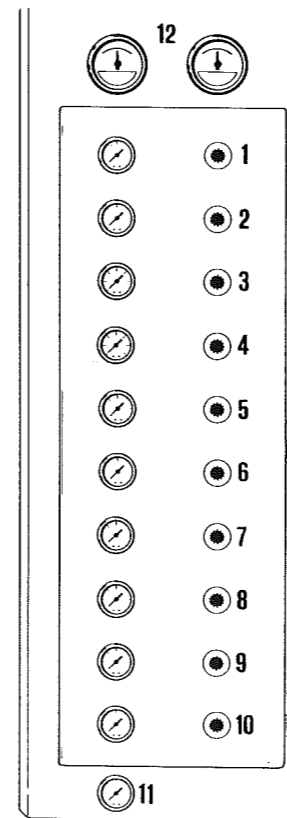

- S0 Emergency off
- S01 Keylock switch: control ON
- S1 System OFF
- S2 System ON
- S4 Booth cleaning
- S5 Alarm ON/OFF
- S6 Illumination
- S7 Virgin powder
- S10 Squeegee manual
- Q0 Master switch
- H0 Control (white)
- H1 System (ON, green)
- H3 Booth cleaning
- H4 Powder below upper level sensor
- H5 Powder truck empty
- H6 Powder truck full
- H7 Squeegee fault
- H8 Pressure rise
- H9 Motor fault
- H10 Alarm (off)
- H11 Virgin powder (OFF)
- H12 Virgin powder (ON)
- H13 Virgin powder hopper empty

Pneumatic panel

- 1 Virgin powder hopper
- 2 Virgin powder tube
- 3 Fluidizing canal
- 4 Fluidizing bed
- 5 Connecting frame (ventilator housing/ filter truck)
- 6 Pressure tank
- 7 Cable rinsing
- 8 Screen
- 9 Continuous fluidization
- 10 Prefluidization
- 11 Compressed-air inlet
- 12 Differential pressure (sinter lamella filters)

 *DOCUMENTATION CRS-L/CRS-E *
 *EDITION JANUARY 1989 *
 COPYRIGHT BY RANSBURG-GEMA AG, 9015 ST. GALLEN/SWITZERLAND
 *WE RESERVE THE RIGHT TO MAKE CHANGES WITH RESPECT TO *
 *SIZES, TECHNICAL DATA, EQUIPMENT, WITHOUT PRIOR NOTICE *
