

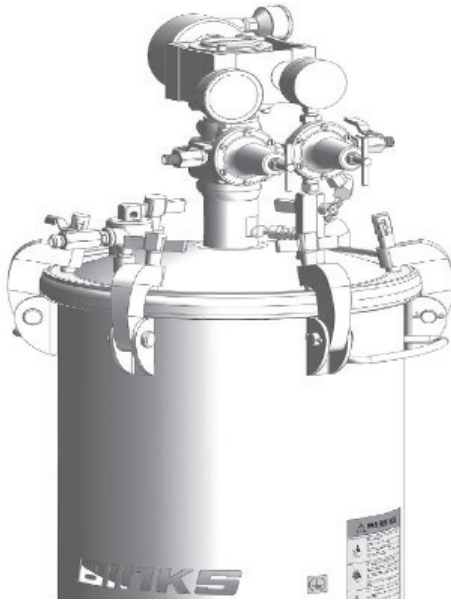

183G (GALVANIZED) 5, 10, AND 15 GALLON ASME TANKS



Important: Read and follow all instructions and SAFETY PRECAUTIONS before using this equipment. Retain for future reference.

GALVANIZED 5-GALLON MODELS		
Tank Model	Regulation	Agitation
183G-500	None	None
183G-510	Single (Regulated air to tank only)	None
183G-512	Single (Regulated air to tank only)	Manual
183G-513	Single (Regulated air to tank only)	Gear-reduced (Heavy-duty)
183G-520	Double (Regulated air to tank and gun)	None
183G-523	Double (Regulated air to tank and gun)	Gear-reduced (Heavy-duty)
183G-530	Extra Sensitive	None
183G-533	Extra Sensitive	Gear-reduced (Heavy-duty)
183G-540	Extra Sensitive w/ gun regulation	None
183G-543	Extra Sensitive w/ gun regulation	Gear-reduced (Heavy-duty)

GALVANIZED 10-GALLON MODELS		
Tank Model	Regulation	Agitation
183G-1000	None	None
183G-1010	Single (Regulated air to tank only)	None
183G-1013	Single (Regulated air to tank only)	Gear-reduced (Heavy-duty)
183G-1020	Double (Regulated air to tank and gun)	None
183G-1023	Double (Regulated air to tank and gun)	Gear-reduced (Heavy-duty)
183G-1030	Extra Sensitive (Single)	None
183G-1033	Extra Sensitive (Single)	Gear-reduced (Heavy-duty)
183G-1040	Extra Sensitive w/ gun regulation	None
183G-1043	Extra Sensitive w/ gun regulation	Gear-reduced (Heavy-duty)

DESCRIPTION

Binks pressure feed tanks are intended for use as a pressure container to supply material at a constant preset pressure up to a maximum of 110 psi. The tanks are built to ASME specifications. Also certified for vacuum operation.

ACTUAL CAPACITIES

5-Gallon holds 9.8 gallons or a 5-gallon pail

10-Gallon holds 11.8 gallons

15-Gallon holds 19.8 gallons

GALVANIZED 15-GALLON MODELS		
Tank Model	Regulation	Agitation
183G-1500	None	None
183G-1510	Single (Regulated air to tank only)	None
183G-1513	Single (Regulated air to tank only)	Gear-reduced (Heavy-duty)
183G-1520	Double (Regulated air to tank and gun)	None
183G-1523	Double (Regulated air to tank and gun)	Gear-reduced (Heavy-duty)
183G-1530	Extra Sensitive (Single)	None
183G-1533	Extra Sensitive (Single)	Gear-reduced (Heavy-duty)
183G-1540	Extra Sensitive w/ gun regulation	None
183G-1543	Extra Sensitive w/ gun regulation	Gear-reduced (Heavy-duty)

In this part sheet, the words **WARNING**, **CAUTION** and **NOTE** are used to emphasize important safety information as follows:

WARNING

Hazards or unsafe practices which could result in severe personal injury, death or substantial property damage.

CAUTION

Hazards or unsafe practices which could result in minor personal injury, product or property damage.

NOTE

Important installation, operation or maintenance information.

WARNING

Read the following warnings before using this equipment.



READ THE MANUAL

Before operating finishing equipment, read and understand all safety, operation and maintenance information provided in the operation manual.



OPERATOR TRAINING

All personnel must be trained before operating finishing equipment.



EQUIPMENT MISUSE HAZARD

Equipment misuse can cause the equipment to rupture, malfunction, or start unexpectedly and result in serious injury.



LOCK OUT / TAG-OUT

Failure to de-energize, disconnect, lock out and tag-out all power sources before performing equipment maintenance could cause serious injury or death.



AUTOMATIC EQUIPMENT

Automatic equipment may start suddenly without warning.



PRESSURE RELIEF PROCEDURE

Always follow the pressure relief procedure in the equipment instruction manual.



KEEP EQUIPMENT GUARDS IN PLACE

Do not operate the equipment if the safety devices have been removed.



KNOW WHERE AND HOW TO SHUT OFF THE EQUIPMENT IN CASE OF AN EMERGENCY



WEAR SAFETY GLASSES

Failure to wear safety glasses with side shields could result in serious eye injury or blindness.



INSPECT THE EQUIPMENT DAILY

Inspect the equipment for worn or broken parts on a daily basis. Do not operate the equipment if you are uncertain about its condition.



NEVER MODIFY THE EQUIPMENT

Do not modify the equipment unless the manufacturer provides written approval.



NOISE HAZARD

You may be injured by loud noise. Hearing protection may be required when using this equipment.



PROJECTILE HAZARD

You may be injured by venting liquids or gases that are released under pressure, or flying debris.



PINCH POINT HAZARD

Moving parts can crush and cut. Pinch points are basically any areas where there are moving parts.



STATIC CHARGE

Fluid may develop a static charge that must be dissipated through proper grounding of the equipment, objects to be sprayed and all other electrically conductive objects in the dispensing area. Improper grounding or sparks can cause a hazardous condition and result in fire, explosion or electric shock and other serious injury.



WEAR RESPIRATOR

Toxic fumes can cause serious injury or death if inhaled. Wear a respirator as recommended by the fluid and solvent manufacturer's Safety Data Sheet.



TOXIC FLUID & FUMES

Hazardous fluid or toxic fumes can cause serious injury or death if splashed in the eyes or on the skin, inhaled, injected or swallowed. LEARN and KNOW the specific hazards or the fluids you are using.



FIRE AND EXPLOSION HAZARD

Improper equipment grounding, poor ventilation, open flame or sparks can cause a hazardous condition and result in fire or explosion and serious injury.



MEDICAL ALERT

Any injury caused by high pressure liquid can be serious. If you are injured or even suspect an injury:

- Go to an emergency room immediately.
- Tell the doctor you suspect an injection injury.
- Show the doctor this medical information or the medical alert card provided with your airless spray equipment.
- Tell the doctor what kind of fluid you were spraying or dispensing.



GET IMMEDIATE MEDICAL ATTENTION





To prevent contact with the fluid, please note the following:

- Never point the gun/valve at anyone or any part of the body.
- Never put hand or fingers over the spray tip.
- Never attempt to stop or deflect fluid leaks with your hand, body, glove or rag.
- Always have the tip guard on the spray gun before spraying.
- Always ensure that the gun trigger safety operates before spraying.

IT IS THE RESPONSIBILITY OF THE EMPLOYER TO PROVIDE THIS INFORMATION TO THE OPERATOR OF THE EQUIPMENT. FOR FURTHER SAFETY INFORMATION REGARDING THIS EQUIPMENT, SEE THE GENERAL EQUIPMENT SAFETY BOOKLET (77-5300).

5/10/15-GALLON GALVANIZED TANK ASSEMBLIES – SAFEGUARDS

The following hazards may occur during the normal use of this equipment. Please read the following chart.

HAZARD	CAUSE	SAFEGUARDS
Fire 	Solvents and coatings can be highly flammable or combustible, especially when sprayed.	<ol style="list-style-type: none"> 1. Adequate exhaust must be provided to keep the air free of accumulations of flammable vapors. 2. Smoking must never be allowed in the spray area. 3. Fire extinguishing equipment must be present in the spray area.
Fire – Pressure tank 	Vapors from flammable liquids can catch fire or explode.	Keep tank at least 10 feet away from sources of ignition. Ignition sources include hot objects, mechanical sparks, and arcing (non -explosion proof) electrical equipment.
Explosion Hazard – Pressure Tank – Static Electricity 	Static electricity is created by the flow of fluid through the pressure tank and hose. If all parts are not properly grounded, sparking may occur. Sparks can ignite vapors from solvents and the fluid being sprayed.	<ol style="list-style-type: none"> 1. Ground the pressure tank by connecting one end of 12 gauge (minimum) ground wire to the pressure tank and the other end to a true earth ground. Local codes may have additional grounding requirements. 2. See illustration on page 6 for grounding and grounding hardware required.
Explosion Hazard – Pressure Tank – Rupture 	Making changes to a pressure tank will weaken it.	<ol style="list-style-type: none"> 1. Never drill into, weld, or modify the tank in any way. 2. Do not adjust, remove, or tamper with the safety valve. If replacement is necessary, use the same type and rating of valve.
Explosion Hazard – Galvanized Tanks – Material Compatibility 	Halogenated hydrocarbon solvents – for example 1-1-1 Trichloroethane and methylene chloride – can chemically react with aluminum parts and components and cause an explosion hazard. These solvents will also corrode the galvanized tank coating.	<ol style="list-style-type: none"> 1. Read the label or data sheet for the material. Do not use materials containing these solvents with galvanized pressure tanks. Stainless steel tank models may be used with halogenated solvents. 2. Refer to specifications chart to ensure that fluids are chemically compatible with the tank wetted parts. Before placing fluids or solvents in tank, always read accompanying manufacturer's literature.
General Safety	Improper operation or maintenance may create a hazard.	Operators should be given adequate training in the safe use and maintenance of the equipment (in accordance with the requirements of NFPA-33, Chapter 15 in U.S.) Users must comply with all local and national codes governing ventilation, fire precautions, operation, maintenance, and housekeeping (in the U.S., these are OSHA sections 1910.94 and 1910.107, and NFPA-33.

WARNING

High pressure can cause serious injury.

Pressure is maintained in a pressure tank after the system has been shut down.

Always follow this procedure to relieve pressure from the tank.

PRESSURE RELIEF PROCEDURE

To reduce the risk of injury, follow the pressure relief procedure below

- Before checking or servicing any part of the spray system
 - Before attempting removal of fill port cap or tank cover
 - Whenever the tank is left unattended
1. Turn off the main air supply to the tank.
 2. Close the air inlet valve located on the tank air manifold.
 3. Bleed off air in the tank by turning the air relief valve (5) thumb screw counterclockwise. Wait until all the air has escaped through the valve before removing the pressure tank cover or fill port cap.
 4. Leave the air relief valve open until you have reinstalled the tank cover or fill port cap.

5/10/15-GALLON GALVANIZED TANK ASSEMBLIES – SPECIFICATIONS & OPTIONS

SPECIFICATIONS	
	GALVANIZED TANKS
Maximum Working Pressure	110 psi
Tank Shell	SA-414 Steel, Galvanized (Zinc)
Tank Lid	SA-414 Steel, Galvanized (Zinc)
Fluid Tube	3/8 in. Steel Pipe, Galvanized
Fluid Outlet (Elbow)	Steel, Zinc Plate
Fluid Valve, Outlet	Brass, Nickel Plate 3/8-18 NPS(M)
Agitator Paddle/Propeller	Nylon, Glass Filled
Agitator Shaft	Steel, Zinc Plate
Agitator Shaft Seal	Engineered PTFE, Stainless Steel
Air Manifold	Steel, Zinc Plate
Plug (Air Manifold Coupling)	Steel, Zinc Plate
Bottom Outlet (Optional Kit)	304 Stainless Steel 3/4-14 NPS(M)

TANK CAPACITIES	
Nominal Capacity	Actual Capacity
5 US Gallons	9.8 US Gallons
10 US Gallons	11.8 US Gallons
15 US Gallons	19.8 US Gallons

AIR CONTROL OPTIONS	
TYPE	APPLICATION
No Regulation (Air inlet pressure gauge only)	Holding tanks, Transfer tanks, Used where precision fluid pressure control is not required.
Standard Single Regulation	Provides standard fluid pressure control only. For use where precision control of both fluid and air pressures is not required. Also Used where atomization air can be taken from filter/regulator air lines.
Standard Double Regulation	Precision control for use with materials that are best applied at low, closely controlled, fluid and atomization air pressures. Used with portable air compressors or with air lines when no other means of air pressure regulation is available.
Extra Sensitive Regulation	Provides extremely accurate, low pressure, fluid pressure control
Extra Sensitive Regulation with Standard Gun Regulation	Provides extremely accurate, low pressure, fluid pressure control plus precision control of spray gun atomizing air.

AGITATION OPTIONS	
TYPE	APPLICATION
No Agitation	Materials that require minimal or no mixing and/or readily hold any solids in suspension.
Gear-reduced Drive Agitation	Heavy-duty agitator for medium to high viscosity materials that require mixing and/or solids suspension.
Direct Drive Agitation	

5/10/15-GALLON GALVANIZED TANK ASSEMBLIES – OPERATION & SERVICE CHECKS

⚠ WARNING

High pressure can cause serious injury.

Pressure is maintained in a pressure tank after the system has been shut down.

Follow the pressure-relief procedure on page 3 before opening the lid or fill port or performing maintenance on the tank.

PREPARATION

Mix and prepare material to be used according to manufacturer's instructions. Strain material through a fine mesh screen to remove lumps, skin, and foreign matter that might enter and clog fluid passages and/or spray equipment.

Follow pressure relief procedure above.

To add material to the tank, remove the lid and pour directly into the tank or container.

If desired, a U.S. or metric 1 gallon pail of fluid can be placed directly into the tank.

Replace the lid assembly and tighten thumb screws (17) securely.

The air supply to the tank should include a filter/water separator to filter dirt from the air and remove water and oil.

Connect the material hose to the fluid outlet ball valve (8).

OPERATION

1. Close the air inlet valve to tank. Turn handle on regulator counterclockwise until spring tension is relieved.
2. Turn on air supply to the tank.
3. Open the air inlet valve to the tank.
4. Open the fluid outlet valve.
5. Turn handle on tank pressure regulator clockwise to pressurize tank.
6. Turn on atomization air to spray gun at source of supply.
7. Test spray. For further instructions consult literature provided with spray gun.
8. If an air motor driven agitator is used, start the agitator by slowly opening up the needle valve. Air motor speed should be regulated according to the nature of the material being agitated.
5. Loosen spray gun air cap retaining ring about three turns.
6. Turn on air supply.
7. Cup cloth over air cap on the gun and pull trigger. This will force material back through the hose into the tank.
8. Empty and clean tank and parts that come into contact with material. Use a solvent compatible with material being used.
9. Pour solvent into tank.
10. Replace lid and tighten thumb screws and clamps.
11. Spray until clean solvent appears.
12. Repeat steps 4 through 8.

MAINTENANCE

To clean equipment, proceed as follows:

1. Turn off the air supply.
2. Follow the pressure relief procedure.
3. Turn T-handle adjusting screw on tank fluid pressure regulator counterclockwise until no spring pressure is felt.
4. Loosen thumb screws (17), tip clamps (16) back and tip lid (11) to one side of tank. Do not remove lid from tank.

LUBRICATION – Agitated Models

Refer to the service manual provided with the air motor for lubrication information.

The bearings in the agitator bearing assembly are impregnated with special non-gumming oil. Additional lubrication is not required.

The agitator shaft seal does not require lubrication.

SERVICE CHECKS

CONDITION	CAUSE	CORRECTION
Air escaping from port on regulator cap.	Broken or damaged diaphragm	Replace diaphragm.
Pressure creepage registered on gauge.	Dirty or worn valve seat in regulator.	Clean or replace valve seat.
Material tends to settle out rapidly.	Not enough agitation of material.	Increase agitation.
Air leakage at agitator seal.	Defective seal assembly.	Replace.
Paint getting into bearing assembly of agitator.	1. Paint level in tank too high. 2. Defective agitator shaft seal.	1. Keep fluid level under bearing ass'y. 2. Replace
Fluid or air leak at lid gasket.	1. Thumb screw not tight. 2. Defective lid gasket.	1. Tighten. 2. Replace.
Fluid or air leak at fill port gasket.	1. Fill port cap not tight. 2. Defective fill port gasket.	1. Tighten. 2. Replace.
Air mixing with paint	1. Fluid tube not sealed to lid. 2. Excessive agitation.	1. Tighten fluid tube into lid. 2. Reduce speed of agitator.

5/10/15-GALLON GALVANIZED TANK ASSEMBLIES

NOTE
Open side of the shaft seal (8) faces downward.
Retainer (9) required only for vacuum operation.

NOTE
Use PTFE based thread sealant on all air and fluid connections.

CAUTION
Use 40PSI Safety Valve (12A) with an extra sensitive regulator.

PETROLEUM JELLY/GREASE

Refer to 77-3138 for more information (39).

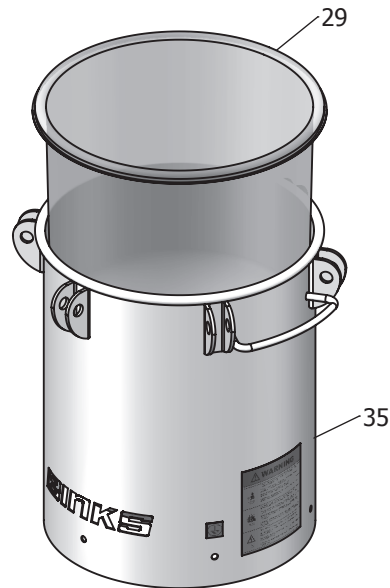
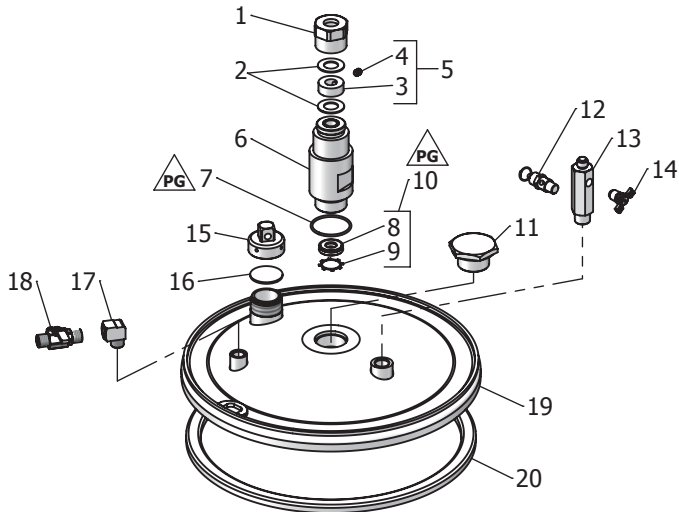
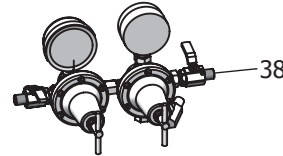
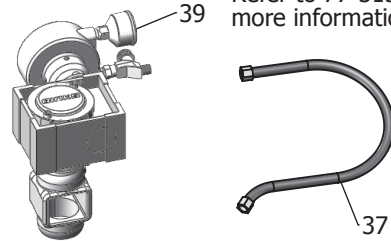

The Stationary Paddle Kit (28) comes standard only on 10 & 15 gallon tanks.

The 5 & 10 gallon tanks come standard with one Agitator Paddle Kit (26).
The 15 gallon comes standard with two.

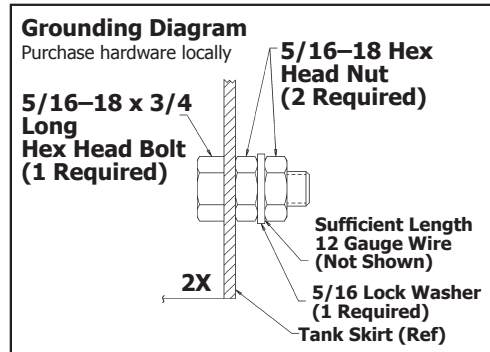
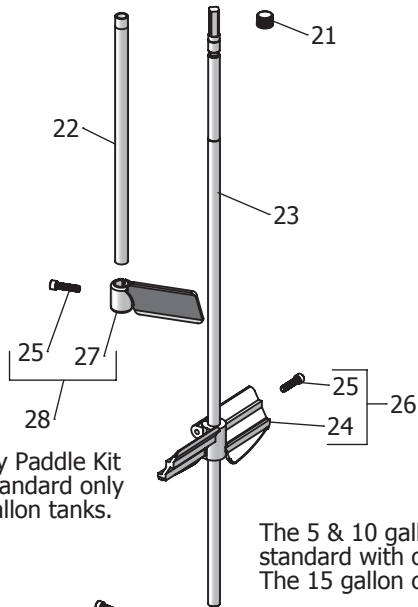

Tank shown with manual agitator

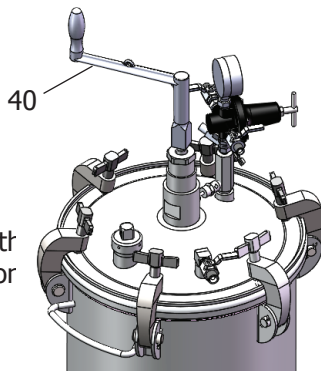

5/10/15-GALLON GALVANIZED TANK ASSEMBLIES – PARTS LIST

ITEM NO.	PART NO.	DESCRIPTION	5-GAL QTY.	10-GAL QTY.	15-GAL QTY.
1	▲ QMS-46	RETAINING NUT	1	1	1
2	▲ QMG-85	THRUST WASHER	2	2	2
3	▲ -----	THRUST COLLAR	1	1	1
4	▲• -----	SET SCREW (5/16-18 X 3/8)	1	1	1
5	QMS-447	THRUST COLLAR KIT (INCL 4 & 5)	1	1	1
6	▲ QMG-409	BEARING ASSY-PLAIN STEEL	1	1	1
7	▲ SSG-8184-K2	O-RING (KIT OF 2)	1	1	1
8	▲ -----	SHAFT SEAL 5/8 I.D.	1	1	1
9	▲ -----	INTERNAL RETAINING RING	1	1	1
10	KK-5042	SHAFT SEAL KIT (INCL 8 & 9)	1	1	1
11	QMS-3	PLUG (NON-AGITATED MODELS ONLY)	1	1	1
12	TIA-4110	SAFETY VALVE ASSY, 110 PSI	1	1	1
12A	TIA-5040	SAFETY VALVE ASSY, 40 PSI (EXTRA SENSITIVE ONLY)			
13	QMG-21	AIR MANIFOLD	1	1	1
14	SS-2707	AIR RELIEF VALVE 1/4 NPT(M)	1	1	1
15	83-524-K	FILL PORT CAP	1	1	1
16	83-1207-K5	FILL PORT CAP GASKET	1	1	1
17	• -----	STREET ELBOW, 3/8-18 NPT (Brass)	1	1	1
18	VA-540	BALL VALVE, 3/8 NPS OUTLET	1	1	1
19	QMG-402-1	TANK LID	1	1	1
20	QM-1458-1	TANK GASKET	1	1	1
21	• -----	PLUG, 1/2-14 NPT (PLATED STEEL)	1	1	1
22	QMS-10-1	FLUID TUBE	1	----	----
22	QMS-11-1	FLUID TUBE	----	1	----
22	QMS-12-1	FLUID TUBE	----	----	1
23	▲ QMS-6	AGITATOR SHAFT	1	----	----
23	▲ QMS-7	AGITATOR SHAFT	----	1	----
23	▲ QMS-8	AGITATOR SHAFT	----	----	1
24	▲ -----	AGITATOR PADDLE	1	1	2
25	▲• -----	SOC HEAD CAP SCREW, 5/16-18 X 1-1/4, S.S.	1	2	3
26	QMS-444-CE	AGITATOR PADDLE KIT (INCL 24 & 25)	1	1	2
27	▲ -----	STATIONARY PADDLE	----	1	1
28	QMS-445-CE	STATIONARY PADDLE KIT (INCL 25 & 27)	----	1	1
29	PTL-408-K20	DISPOSABLE TANK LINER, 5-GAL	1	----	----
29	PTL-412-K8	DISPOSABLE TANK LINER, 10-GAL	----	1	----
29	PTL-415-K10	DISPOSABLE TANK LINER, 15-GAL	----	----	1
30	QM-1352-CE	THUMB SCREW (SEE ITEM 34)	6	6	6
31	• -----	COTTER PIN, 1/8 DIA. X 1" LG. (SEE ITEM 34)	6	6	6
32	-----	CLEVIS PIN (SEE ITEM 34)	6	6	6
33	-----	CLAMP (SEE ITEM 34)	6	6	6
34	+ KK-5014	CLAMP, PIN, & SCREW KIT	6	6	6
35	QMG-505-1	TANK & LUG ASSY, 5-GAL	1	----	----
35	QMG-510-1	TANK & LUG ASSY, 10-GAL	----	1	----
35	QMG-515-1	TANK & LUG ASSY, 15-GAL	----	----	1
36	-----	BOTTOM PLUG	1	1	1
37	HA-57011	AIR HOSE ASS'Y (INCL W/ ITEM 38)	1	1	1
38	SEE PAGES 8 & 9	AIR CONTROL	1	1	1
39	31-452	AIR MOTOR/GEARBOX DRIVE - 183G-XXX3	1	1	1
40	QM-142	HAND CRANK, MANUAL AGITATION	1	----	----

• Purchase locally.

+KK-5014 Clamp, Pin, and Screw Kit includes 1 each of items 30, 31, 32, and 33.

▲ Items available separately or as a complete agitator assembly:

QMG-418 (for 5 gallon tanks)

QMG-419 (for 10 gallon tanks)

QMG-420 (for 15 gallon tanks)

5/10/15-GALLON GALVANIZED TANK ASSEMBLIES – AIR CONTROL

SINGLE REGULATOR AIR CONTROL

Control tank pressure only.

85-470 for non-agitated tanks

85-471 for agitated tanks

*Items with an asterisk are for use with an agitator.

ITEM NO.	PART NO.	DESCRIPTION	85-470	85-471
1	+	HAR-511 AIR REGULATOR	1	1
2	•	----- BUSHING-STL-PLTD – 3/8 (m) x 1/4 (f)	2	2
3		VA-542 BALL VALVE	2	2
4		83-1290 GAUGE – 150 PSI	1	1
5		SSP-8217-ZN SWIVEL ADAPTER	1	1
6	•	----- 1/4 NPT PLUG (SUPPLIED W/ REGULATOR)	1	—
7		H-2008 NIPPLE 1/4 NPS x 1/4 NPT	—	1
8		SSP-30-ZN SWIVEL ELBOW – 1/4 NPT(m) x 1/4 NPS (sw)	—	1

• Purchase locally

+ Refer to 77-2781 for regulator service parts, Repair kit: KK-4977

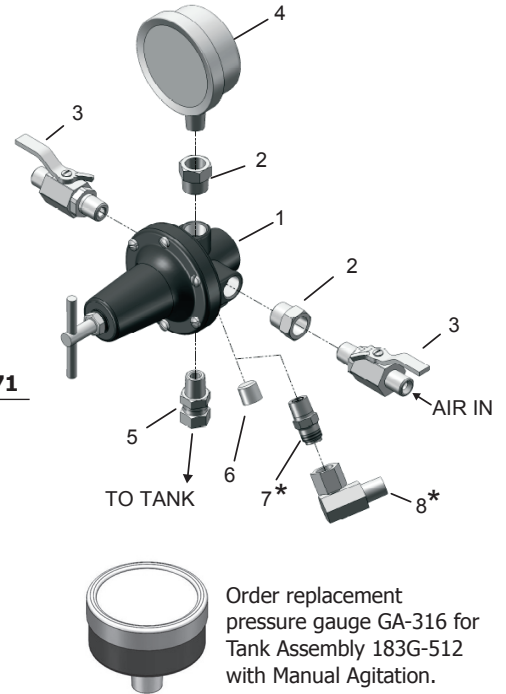

DOUBLE REGULATOR AIR CONTROL

Control tank pressure and spray gun atomization pressure.

85-472 for non-agitated tanks

85-473 for agitated tanks

*Items with an asterisk are for use with an agitator.

ITEM NO.	PART NO.	DESCRIPTION	85-472	85-473
1	+	HAR-511 AIR REGULATOR	1	1
2	•	----- BUSHING-STL-PLTD – 3/8 (m) x 1/4 (f)	2	2
3		VA-542 BALL VALVE	2	2
4		83-1290 GAUGE - 150 PSI	1	1
5		SSP-8217-ZN SWIVEL ADAPTER	1	1
6	•	----- 1/4 NPT PLUG (SUPPLIED W/ REGULATOR)	2	1
7		83-4233 D.M. NIPPLE 1/4 x 3/8	1	1
8	#	HAR-507 AIR REGULATOR	1	1
9		83-1355 GAUGE - 100 PSI	1	1
10		H-2008 NIPPLE 1/4 NPS x 1/4 NPT	—	1
11		SSP-30-ZN SWIVEL ELBOW – 1/4 NPT(m) x 1/4 NPS (sw)	—	1

• Purchase locally

+ Refer to 77-2781 for regulator service parts, Repair kit: KK-4977

Refer to SB-6-147 for regulator service parts, Repair kit: KK-4977

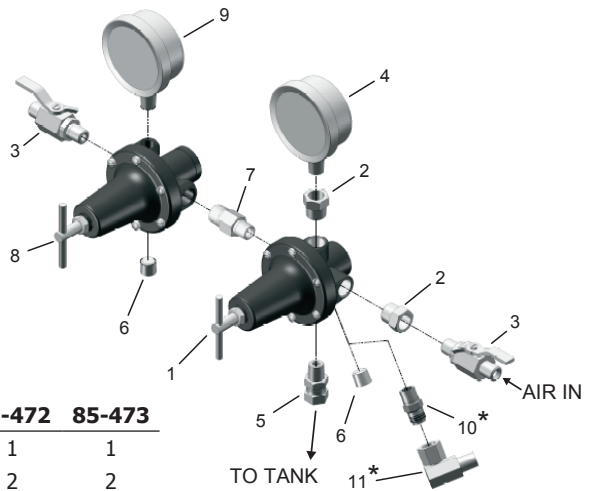

5/10/15-GALLON GALVANIZED TANK ASSEMBLIES – EXTRA SENSITIVE AIR CONTROL

EXTRA SENSITIVE REGULATOR AIR CONTROL SINGLE REGULATOR

Provides extremely high precision control of tank pressure (only) from 0 – 30 PSI. Includes 40 PSI Safety Valve (not shown.)

85-490 for non-agitated tanks
85-491 for agitated tanks

*Items with an asterisk are for use with an agitator.

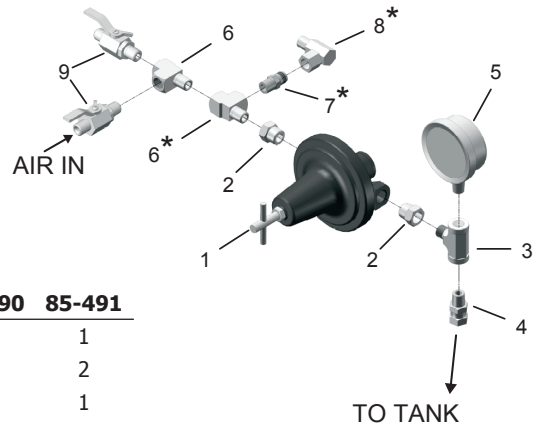

ITEM NO.	PART NO.	DESCRIPTION	85-490	85-491	
1	+	HAR-501	EXTRA-SENSITIVE REGULATOR	1	1
2	•	-----	BUSHING-STL-PLTD – 3/8 (m) x 1/4 (f)	2	2
3		SSP-2629-ZN	MALE BRANCH TEE – 1/4NPT	1	1
4		SSP-8217-ZN	SWIVEL ADAPTER	1	1
5		83-1414	GAUGE - 30 PSI	1	1
6	•	-----	1/4 NPT STREET TEE	1	2
7		H-2008	NIPPLE – 1/4 NPS x 1/4 NPT	—	1
8		SSP-30-ZN	SWIVEL ELBOW – 1/4 NPS(m) x 1/4 NPS (sw)	—	1
9		VA-542	BALL VALVE	2	2
10		TIA-5040	SAFETY VALVE, 40 PSI (NOT SHOWN)	1	1

- Purchase locally
- + Refer to SB-6-131 for regulator service parts, Repair kit: KK-4200

EXTRA SENSITIVE REGULATOR AIR CONTROL DOUBLE REGULATOR

Provides extremely high precision control of tank pressure plus standard regulation for a spray gun. Includes 40 PSI Safety Valve (Not shown.)

85-492 for non-agitated tanks
85-493 for agitated tanks

*Items with an asterisk are for use with an agitator.

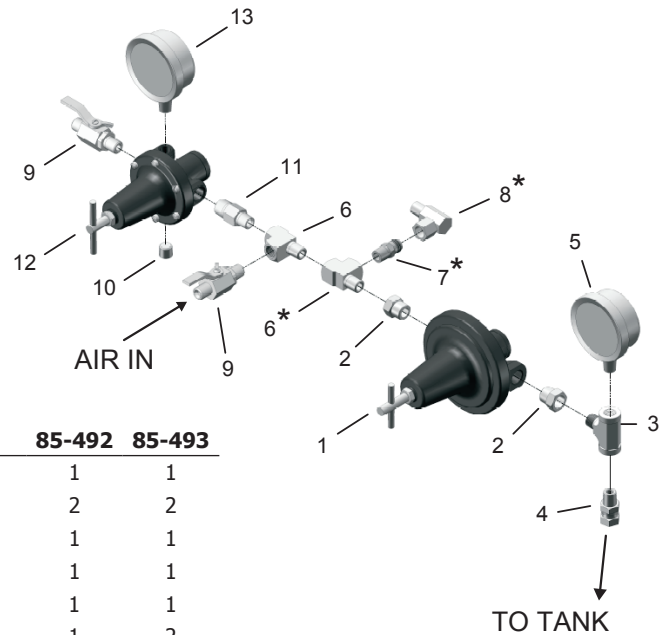

ITEM NO.	PART NO.	DESCRIPTION	85-492	85-493	
1	+	HAR-501	EXTRA-SENSITIVE REGULATOR	1	1
2	•	-----	BUSHING-STL-PLTD – 3/8 (m) x 1/4 (f)	2	2
3		SSP-2629-ZN	MALE BRANCH TEE – 1/4NPT	1	1
4		SSP-8217-ZN	SWIVEL ADAPTER	1	1
5		83-1414	GAUGE - 30 PSI	1	1
6	•	-----	1/4 NPT STREET TEE	1	2
7		H-2008	NIPPLE – 1/4 NPS x 1/4 NPT	—	1
8		SSP-30-ZN	SWIVEL ELBOW – 1/4 NPS(m) x 1/4 NPS (sw)	—	1
9		VA-542	BALL VALVE	2	2
10	•	-----	1/4 NPT PLUG (SUPPLIED W/ REGULATOR)	2	2
11		83-4233	D.M. NIPPLE 1/4 x 3/8	1	1
12	#	HAR-507	AIR REGULATOR	1	1
13		83-1355	GAUGE – 100 PSI	1	1
14		TIA-5040	SAFETY VALVE, 40 PSI (NOT SHOWN)	1	1

- Purchase locally
- + Refer to SB-6-131 for regulator service parts, Repair kit: KK-4200
- # Refer to SB-6-147 for regulator service parts, Repair kit: KK-4977

85-469 CONVERSION TO DOUBLE REGULATOR ASSEMBLY KIT

Convert standard single regulator or extra-sensitive air control to a double regulator air control.

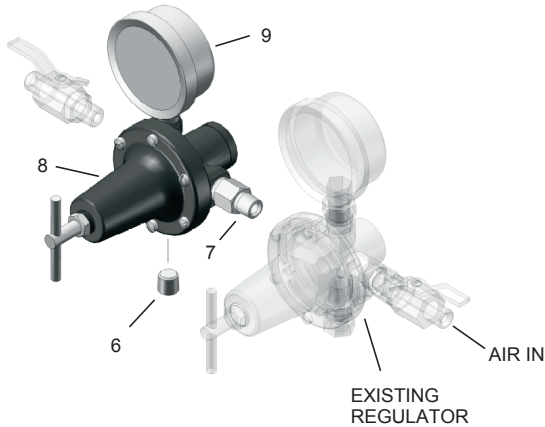

ITEM NO.	PART NO.	DESCRIPTION	QTY.
6	• —	1/4 NPT PLUG (SUPPLIED W/ REGULATOR)	1
7	83-4233	D.M. NIPPLE 1/4 x 3/8	1
8	+ HAR-507	AIR REGULATOR	1
9	83-1355	GAUGE – 100 PSI	1

•Purchase locally
 +Refer to SBBI-6-147 for regulator service parts, Repair kit: KK-4977

QMS-4003 NO REGULATION KIT

Use when fluid pressure in tank is regulated by some other, separate, method of control.

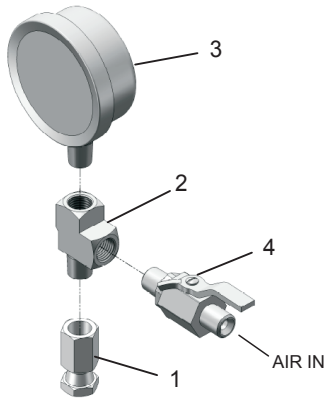

ITEM NO.	PART NO.	DESCRIPTION	QTY.
1	• —	ADAPTER, 1/4 NPT(F) X 1/4 NPS (SW)	1
2	• —	STREET TEE	1
3	83-1290	GAUGE, 150 PSI	1
4	VA-542	BALL VALVE	1

•Purchase locally

BOTTOM OUTLET KIT

BOTTOM OUTLET KIT WITH LEGS

Allows conversion of tank from standard top outlet to bottom outlet. All bottom outlet wetted parts are stainless steel.

183-3001 for 5-, 10- and 15-gallon tanks with 3/4" bottom outlets. Includes three 183-3005 Leg Kits.

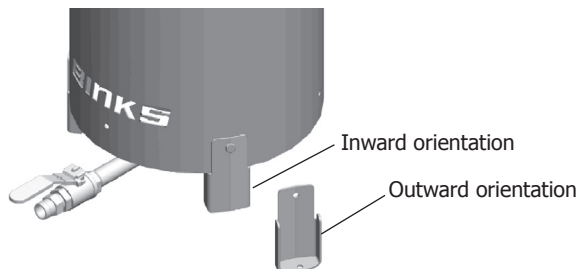

Legs can be oriented either inward or outward to provide flexibility in mounting.

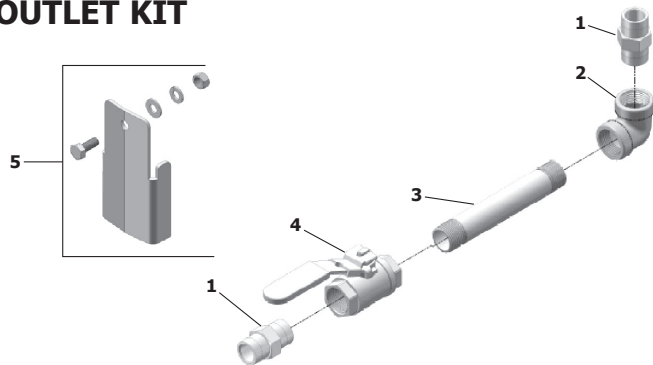

ITEM NO.	PART NO.	DESCRIPTION	QTY.
1	—	ADAPTER, 3/4 NPT-NPS UNIVERSAL	2
2	—	ELBOW, 3/4 NPT (F)	1
3	—	PIPE NIPPLE	1
4	—	BALL VALVE, 3/4 NPT FULL PORT	1
5	183-3005	LEG KIT	3

ACCESSORIES

PROSPECTOR™ PRESSURE TANK STRAINERS FOR 5, 10, AND 15 GALLON TANKS

Prospector™ strainers are an economical way to remove foreign material from paint, stain, lacquer and coatings.

Inner Diameter 11.75" (298.45mm)
Outer Diameter 15.375" (390.52mm)
Height/Depth 3.75" (95.25mm)
Case Qty.....20

PTS-5Gal-K20-200..... 200 micron
(approx. 65 wire mesh)

PTS-5Gal-K20-400..... 400 micron
(approx. 37 wire mesh)

PTS-5Gal-K20-600..... 600 micron
(approx. 28 wire mesh)

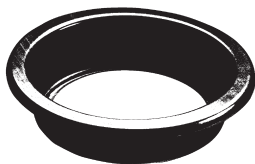

DISPOSABLE TANK LINERS

Single use molded polyethylene tank liners reduce solvent waste and tank cleanup time. The liner is made of tough, durable, leakproof polyethylene and can be used with all compatible materials.

PTL-408-K20 Kit of 20 tank liners (9.8 gal.)

PTL-412-K8 Kit of 8 tank liners (11.8 gal.)

PTL-415-K10 Kit of 10 liners (19.8 gal.)

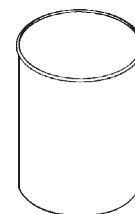

**For additional accessory components including other fluid filter options,
fluid strainer options, clean air units, and hand cleaner towels please visit
Carlisleleft.com.**

WARRANTY POLICY

This product is covered by Carlisle Fluid Technologies' materials and workmanship limited warranty. The use of any parts or accessories, from a source other than Carlisle Fluid Technologies, will void all warranties. Failure to reasonably follow any maintenance guidance provided may invalidate any warranty.

For specific warranty information please contact Carlisle Fluid Technologies.

For technical assistance or to locate an authorized distributor, contact one of our international sales and customer support locations.

Region	Industrial / Automotive	Automotive Refinishing
Americas	Tel: 1-800-992-4657 Fax: 1-888-246-5732	Tel: 1-800-445-3988 Fax: 1-800-445-6643
Europe, Africa, Middle East, India	Tel: +44 (0)1202 571 111 Fax: +44 (0)1202 573 488	
China	Tel: +8621-3373 0108 Fax: +8621-3373 0308	
Japan	Tel: +81 45 785 6421 Fax: +81 45 785 6517	
Australia	Tel: +61 (0) 2 8525 7555 Fax: +61 (0) 2 8525 7575	

For the latest information about our products, visit www.carlisleleft.com

Carlisle Fluid Technologies is a global leader in innovative finishing technologies. Carlisle Fluid Technologies reserves the right to modify equipment specifications without prior notice.

BGK™, Binks®, DeVilbiss®, Hosco®, MS®, and Ransburg® are all registered trademarks of Carlisle Fluid Technologies, LLC.

©2023 Carlisle Fluid Technologies, LLC.
All rights reserved.



16430 North Scottsdale Rd., Suite 450 Scottsdale, AZ 85254 USA