

BINKS[®]

Instruction Manual MX44046PU-XXX Pump



**BINKS****Product Description**Pumps - Maple, MX, MMX, A260, A320,
220, 440, 880, DVP**This Product is designed for use with:**

Solvent and Water based Materials

Suitable for use in hazardous area:

Zone 1 & 2

Protection Level:

I 2 G X

Manufacturer:Binks,
Justus-von-Liebig - Strasse,
63128 Dietzenbach. DE**EU Declaration of Conformity**

We: Binks declare that the above product conforms with the Provisions of:
Machinery Directive 2006/42/EC
ATEX Directive 94/9/EC

by complying with the following statutory documents and harmonized standards:

EN ISO 12100: Safety of Machinery - General Principles for Design

EN ISO 4413: Hydraulic Fluid Power - General Rules and safety requirements

EN ISO 4414: Pneumatic Fluid Power - General Rules and safety requirements

EN 12621: Machinery for the supply and circulation of coating materials under pressure - Safety requirements

EN1127-1: Explosive atmospheres - Explosion prevention - Basic concepts

EN 13463-1: Non electrical equipment for use in potentially explosive atmospheres - Basic methods and requirements

EN 13463-5: Non electrical equipment for use in potentially explosive atmospheres - Protection by constructional safety

Providing all conditions of safe use stated within the product manuals have been complied with and that the final equipment into which this product is installed has been re-assessed as required, in accordance with essential health and safety requirements of the above standards, directives and statutory instruments and also installed in accordance with any applicable local codes of practice.

D Smith (General Manager)
01 November 2012

Specification

Feature	Unit
Flow at 60 cycles/min	7.2 US Gal. /min. 26.4 Litres/min.
Flow per cycle	0.12 US Gallons 0.440 Litres
Recommended intermittent cycle rate	25 cycles/min
Pump Stroke	5" 127 mm
Ratio	46:1
Maximum Fluid Pressure	4669 PSI 322 BAR
Fluid Inlet Fluid Outlet	1½" NPT 1¼" NPT
Weight	165 Pounds 81 KG
Rod Upper Packing Seal	PTFE + UHMWPE
Rod Lower Packing Seal	PTFE + UHMWPE
Air Inlet	¾" NPS/BSP
Air Quality ISO 8573.1 Class 3.3.2	Dirt 5 microns Water -20°C@7bar (0.1g/m³) Oil 0.1mg/m³

 **WARNING**

Directions for Working Safety

This Product has been constructed according to advanced technological standards and is operationally reliable. Damage may, however, result if it is used incorrectly by untrained persons or used for purposes other than those for which it was constructed.

The locally current regulations for safety and prevention of accidents are valid for the operation of this product under all circumstances.

International, national and company safety regulations are to be observed for the installation and operation of this product, as well as the procedures involved in maintenance, repairs and cleaning.

These instructions are intended to be read, understood and observed in all points by those responsible for this product. These operating and maintenance instructions are intended to ensure trouble free operation. Therefore, it is recommended to read these instructions carefully before start-up. Binks PCE cannot be held responsible for damage or malfunctions resulting from the non-observance of the operating instructions. These instructions including regulations and technical drawings may not be copied, distributed, used for commercial purposes or given to others either in full or in part without the consent of Binks PCE.

We reserve the right to alter drawings and specifications necessary for the technical improvement of this product without notice.



Equipment Misuse Hazard

Equipment misuse can cause the equipment to rupture or malfunction and result in serious injury.

- This equipment is for professional use only.
- Read all instruction manuals, tags, and labels before operating the equipment.
- Use the equipment only for its intended purpose.
- Do not alter or modify this equipment. Use only genuine Binks PCE parts and accessories.
- Check equipment daily. Repair or replace worn or damaged parts immediately.
- Do not exceed the maximum working pressure stated on the equipment or in the Technical Data for your equipment. Do not exceed the maximum working pressure of the lowest rated component in your system.
- Use fluids and solvents which are compatible with the equipment wetted parts. Refer to the Technical Data section of all equipment manuals. Read the fluid and solvent manufacturer's warnings.
- Route hoses away from traffic areas, sharp edges, moving parts, and hot surfaces. Do not expose hoses to temperatures above 82°C (180°F) or below -40°C (-40°F).
- Do not lift pressurized equipment.
- Comply with all applicable local, state, and national fire, electrical, and safety regulations.



Fire, Explosion and Electric Shock Hazard

Improper grounding, poor ventilation, open flames or sparks can cause a hazardous condition and result in a fire, explosion, or electric shock.

When installed and operated in accordance with its instructions, the pump is approved for operation in Zone 1 (Europe) & Division 1 (North America), hazardous locations. (ATEX Cat 2)

- Electrical equipment must be installed, operated, and serviced only by trained, qualified personnel who fully understand the requirements stated in this instruction manual.
- Ground the equipment and all other electrically conductive objects in the spray area. After grounding test with ohmmeter to ensure earth continuity is 1 ohm or less.
- Keep all covers tight while the motor is energized.
- If there is any static sparking or you feel an electric shock while using this equipment, stop spraying/dispersing immediately. Do not use the equipment until you identify and correct the problem.
- Provide fresh air ventilation to avoid the build up of flammable fumes from solvents or the fluid being pumped.
- Keep the pumping area free of debris, including solvent, rags, and gasoline.
- Electrically disconnect all equipment in the pumping area.
- Extinguish all open flames or pilot lights in the spray/dispense area.
- Do not smoke in the spray/dispense area.
- Do not turn on or off any light switch in the spray/dispense area while operating or if fumes are present.



 **WARNING**



READ THE MANUAL
Before operating equipment, read and understand all safety, operation and maintenance information provided in the operation manual.



WEAR SAFETY GLASSES
Failure to wear safety glasses with side shields could result in serious eye injury or blindness.



DE-ENERGIZE, DEPRESSURIZE, DISCONNECT AND LOCK OUT ALL POWER SOURCES DURING MAINTENANCE
Failure to De-energize, disconnect and lock out all power supplies before performing equipment maintenance could cause serious injury or death.



NOISE HAZARD
You may be injured by loud noise. Hearing protection may be required when using this equipment.



OPERATOR TRAINING
All personnel must be trained before operating equipment.



KNOW WHERE AND HOW TO SHUT OFF THE EQUIPMENT IN CASE OF AN EMERGENCY



KEEP EQUIPMENT GUARDS IN PLACE
Do not operate the equipment if the safety devices have been removed.



HIGH PRESSURE CONSIDERATION
High pressure can cause serious injury. Relieve all pressure before servicing. Hose leaks, or ruptured components can inject fluid into your body and cause extremely serious injury.

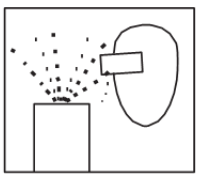

PROJECTILE HAZARD
You may be injured by venting liquids or gases that are released under pressure, or flying debris.



AUTOMATIC EQUIPMENT
Automatic equipment may start suddenly without warning.



PINCH POINT HAZARD
Moving parts can crush and cut. Pinch points are basically any areas where there are moving parts.

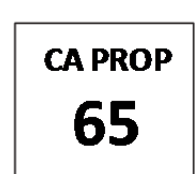

PROP 65 WARNING
WARNING: This product contains chemicals known to the State of California to cause cancer and birth defects or other reproductive harm.



MAGNETIC FIELD PRESENT
You may be subjected to magnetic fields which may interfere with the operation of certain pacemakers.



MAGNET HAZARD
Take care when handling magnets. Avoid getting magnets in close proximity of each other. Injury or damage to magnets may result.

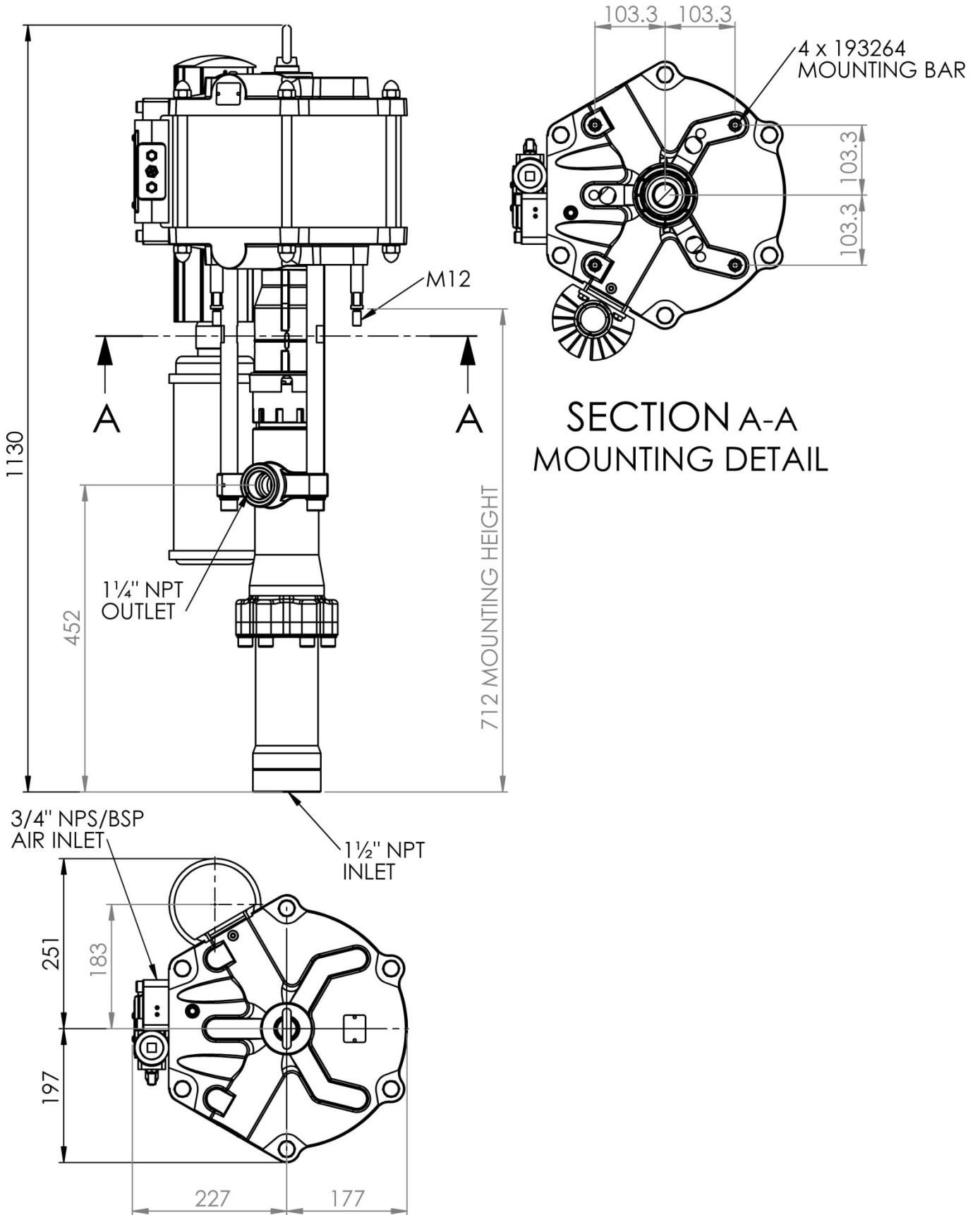

General Description

The MX44046PU-XXX fluid paint pump is designed for pumping High Viscosity materials such as Mastic, PVC, Underseals, Sound deadeners and other similar materials.

The fluid section is a 'ROD' type design which means the rod displaces the material and is the only wear contact with the packings. A two-ball check valve system ensures precise, smooth volume output. Tungsten Carbide ball seats ensure maximum operating life between servicing.

The interior design maintains high flow capacity with minimum pressure drop ensuring high efficiency; special surface treatments provide a smooth micro surface making cleaning and flushing easier.

The piston and rod seals are the chevron type, which can be adjusted by means of a gland nut, should wear occur, a preloaded wave spring is employed to adjust and maintain the lower chevron packing preload when wear occurs. A built in Solvent cup cleans and lubricates the pump rod and seals to prolong working life.

The air motor also utilises the Binks quick exhaust technology to prevent air valve freezing conditions when high cycle speeds are employed.

The air motor is furnished with an exhaust muffler to control air exhaust noise emission. An adapter kit is also available to facilitate connection to a piped exhaust system if required.

Installation

This pump should be flushed with a suitable compatible solvent prior to use.

It is recommended that a propriety 1/2" BSP Filter / Regulator is used to provide final control of the compressed air to the air motor.

Mount the pump securely and position the pump at a convenient height to allow for maintenance, visual observation, and periodic inspection.



The Pump Assembly must be connected to a suitable earth ground to ensure that there is no possibility of static build up.

Attach suitable pipework or flexible hoses designed to meet the working pressure of the pump assembly (dependent on pump ratio) to the inlet and outlet connections, e.g. 1½" Inlet and 1¼" Outlet.

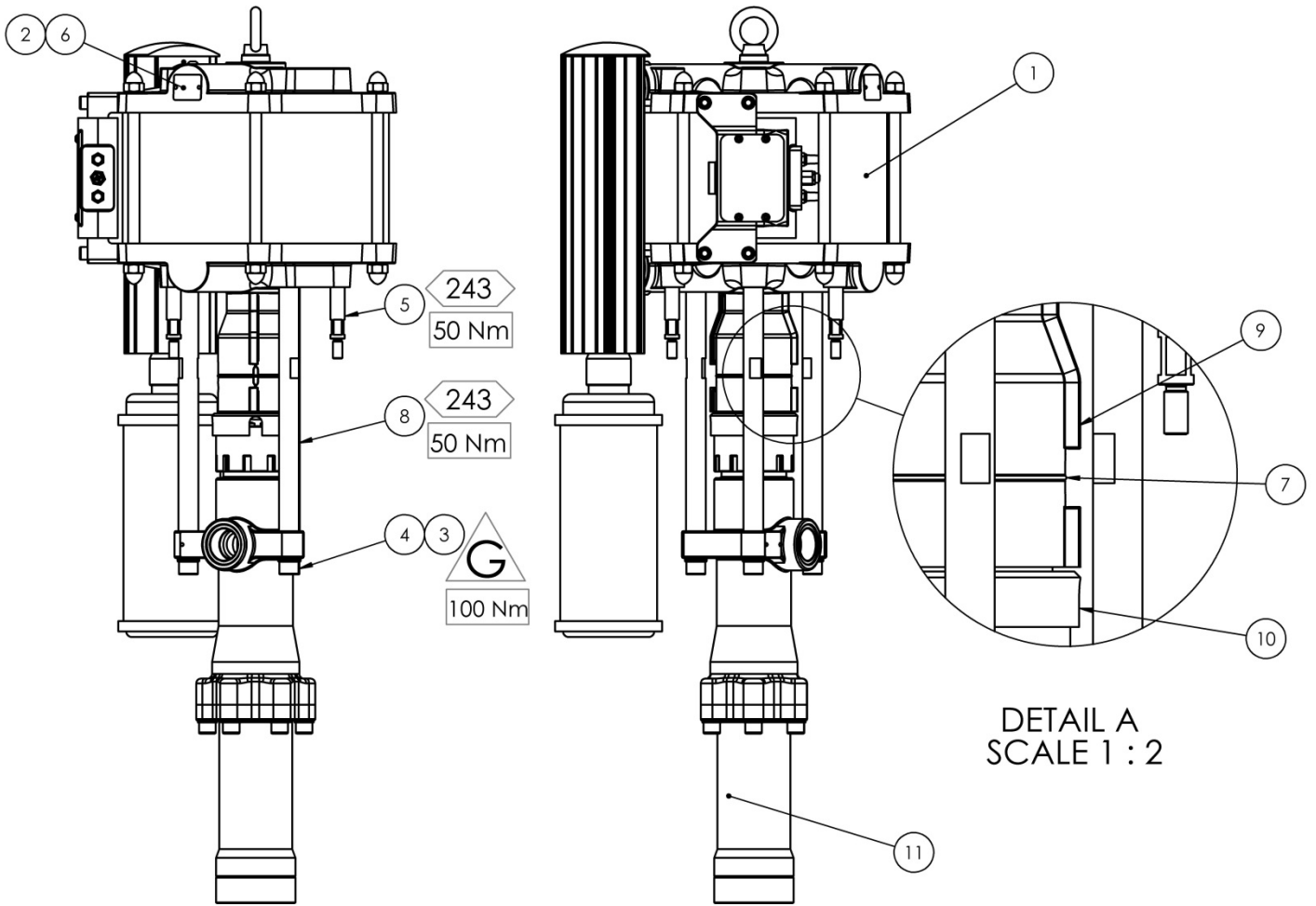
Set the pump speed to a slow cycle rate and start the pump to remove any air from the fluid circuit. Inspect for any air or fluid leaks.

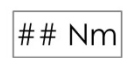

KEY

-  = GREASE (AGMD-010)
-  = LOCTITE
-  = TORQUE

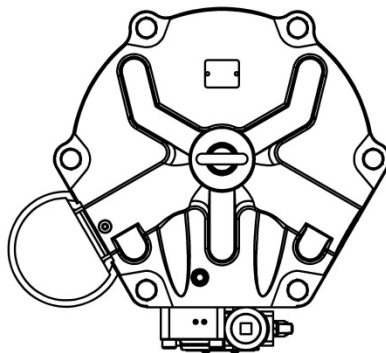

Parts List – ‘MX44046PU-CMH/SMH Pump Assembly’				
ITEM	PART No	DESCRIPTION	QTY	REMARKS
1	104038	A320 AIR MOTOR	1	
2	164838	RIVET	2	
3	165100	M16 SPRING WASHER	3	
4	165594	M16 x 60 SOCKET CAPSCREW	3	
5	193264	AIR MOTOR MOUNTING BAR	4	
6	193540	LABEL	1	
7	193543	COVER CLIP	1	
8	193616	TIE ROD	3	
9	193938	FX440 HAND GUARD	2	
10	193940	FX440 GUARD ADAPTOR	1	
11	FX440PU-SMH	FX440PU-SMH FLUID SECTION	1	
11	FX440PU-CMH	FX440PU-CMH FLUID SECTION	1	

Replacement Spares Kits			
No.	Part No.	Description	Remarks
1	250682	Air Motor Overhaul Kit	Air Piston Seal Shaft seals and bearing All O-rings QEV cups Pilot Valves inc O-rings
2	250647	Air Motor Control Valve Kit	Main Spool Valve inc. O-rings
3	250696	Fluid Section Seal Kit	All O-rings All Packings
Check Main Parts List in Air Motor & Fluid Section Manuals for details of individual Kit Contents			

Pump Accessories		
PART No	DESCRIPTION	REMARKS
192506	Exhaust Tube Adapter (1½" NB hose)	For piped exhaust
0114-014178	Earth Wire	
MXA-C13ALM5-H34	Air Control Including Hose	Air Filter Regulator (0.5m Hose)
AGMD-010	Kluber Isoflex Topas NB 52 (Grease type #)	50 ml Tube

Preventative Maintenance
<p>Check daily to ensure that there is the correct type of lubricant material present in the solvent cup; this should be compatible with the material being pumped. Confirmation from the material supplier should be sought to ensure compatibility to prevent the risk of contamination.</p> <p>Check daily for excessive material leaks into the solvent cup</p> <p>A universal lubricant is available - Wet Sol 'Plus' Binks Part Number 863009</p>

Fault Finding		
Symptom	Possible Cause	Remedy
Motor will not run	<ul style="list-style-type: none"> a. No Air supply b. Air piston seal worn. c. Pilot valve assemblies inoperable. d. Main air valve inoperable e. QE valve defective 	<ul style="list-style-type: none"> a. Check air and fluid supply ball valves and supply hoses. b. Replace Piston seal c. Switch/interchange pilot valves to isolate faulty pilot valve and clean/replace. d. Check clean/replace Air valve. e. Check for constant exhaust air when pump is not in a stalled condition. Check/replace QE cups
Pump runs but has excessive pulsation	<ul style="list-style-type: none"> a. Worn piston seal. b. Worn/failed shaft seals. c. Damaged Exhaust Valve d. Damaged Pilot Valve e. Air exhaust restricted. 	<ul style="list-style-type: none"> a. Replace seal b. Replace shaft bearing / seal housing. c. Inspect / clean and replace as required d. Inspect / clean and replace as required e. Inspect / clean and replace as required
Leak from rod seal packings	Seal wear or damage to packing material	Stop the pump and relieve all material pressure. Tighten the gland nut until the resistance of the packings clamping the shaft can be felt. Do not over-tighten. Ensure solvent cup has the correct lubricant for the material being pumped present at all times.
	Damaged rod	Replace
Low material flowrate, pump running fast or will not stall (stalling - 1 stroke should not occur in less than 30 seconds)	Contaminates trapped between ball and seat	Strip and clean pump. Check for damage
	Worn or damaged balls/seats	Check for wear; replace balls and / or seats.
	Worn bottom rod seals	Replace
Air entering system	Loose joint on suction side	Check and reseal fittings



Justus-von-Liebig-Straße 31, 63128 Dietzenbach. DE
Tel. +49 (0) 6074 403 1 Fax. +49 (0) 607 403 300
General e-mail: info@finishingbrands.eu

Ringwood Road, Bournemouth, Dorset BH11 9LH. UK
Tel. +44 (0)1202 571 111 Fax. +44 (0)1202 573 488
General e-mail: info@finishingbrands.eu

163-171, Av. des Auréats, 26014 Valence cedex. FR
Téléphone : +33 (0) 4 75 75 27 53 Télécopie: +33 (0) 4 75 75 27 79
General e-mail: info@finishingbrands.eu

USA Canada Customer Service

195 Internationale Blvd.
Glendale Height, IL 60139
630-237-5000

Toll Free Customer Service and
Technical Support 800-992-4657
Toll Free Facsimile 800-246-5732