

# ***BINKS***<sup>®</sup>

## Instruction Manual MX44030PU-XXX Pump



**BINKS**

## Product Description

Pumps - Maple, MX, MMX, A260, A320,  
220, 440, 880, DVP

**This Product is designed for use with:** Solvent and Water based Materials

**Suitable for use in hazardous area:** Zone 1 & 2

**Protection Level:** II 2 G X

**Manufacturer:** Binks,  
Justus-von-Liebig - Strasse,  
63128 Dietzenbach. DE

## EU Declaration of Conformity

**We: Binks declare that the above product conforms with the Provisions of:**

Machinery Directive 2006/42/EC  
ATEX Directive 94/9/EC

**by complying with the following statutory documents and harmonized standards:**

EN ISO 12100: Safety of Machinery - General Principles for Design  
EN ISO 4413: Hydraulic Fluid Power - General Rules and safety requirements  
EN ISO 4414: Pneumatic Fluid Power - General Rules and safety requirements  
EN 12621: Machinery for the supply and circulation of coating materials under pressure - Safety requirements  
EN1127-1: Explosive atmospheres - Explosion prevention - Basic concepts  
EN 13463-1: Non electrical equipment for use in potentially explosive atmospheres - Basic methods and requirements  
EN 13463-5: Non electrical equipment for use in potentially explosive atmospheres - Protection by constructional safety

Providing all conditions of safe use stated within the product manuals have been complied with and that the final equipment into which this product is installed has been re-assessed as required, in accordance with essential health and safety requirements of the above standards, directives and statutory instruments and also installed in accordance with any applicable local codes of practice.

D Smith (General Manager)  
01 November 2012

**Specification**

| Feature                             | Unit   |
|-------------------------------------|--|
| Flow at 60 cycles/min               | 7.2 US Gal. /min.<br>26.4 Litres/min.                        |
| Flow per cycle                      | 0.12 US Gallons<br>0.440 Litres                              |
| Recommended intermittent cycle rate | 25 cycles/min  |
| Pump Stroke                         | 5"<br>127 mm   |
| Ratio                               | 30:1   |
| Maximum Fluid Pressure              | 3045 PSI<br>210 BAR  |
| Fluid Inlet<br>Fluid Outlet         | 1½" NPT<br>1¼" NPT   |
| Weight                              | 165 Pounds<br>75 KG  |
| Rod Upper Packing Seal              | PTFE + UHMWPE  |
| Rod Lower Packing Seal              | PTFE + UHMWPE  |
| Air Inlet                           | ¾" NPS/BSP   |
| Air Quality ISO 8573.1 Class 3.3.2  | Dirt 5 microns<br>Water -20°C@7bar (0.1g/m³)<br>Oil 0.1mg/m³ |

 **WARNING**

**Directions for Working Safety**

This Product has been constructed according to advanced technological standards and is operationally reliable. Damage may, however, result if it is used incorrectly by untrained persons or used for purposes other than those for which it was constructed.

The locally current regulations for safety and prevention of accidents are valid for the operation of this product under all circumstances.

International, national and company safety regulations are to be observed for the installation and operation of this product, as well as the procedures involved in maintenance, repairs and cleaning.

These instructions are intended to be read, understood and observed in all points by those responsible for this product. These operating and maintenance instructions are intended to ensure trouble free operation. Therefore, it is recommended to read these instructions carefully before start-up. Binks PCE cannot be held responsible for damage or malfunctions resulting from the non-observance of the operating instructions. These instructions including regulations and technical drawings may not be copied, distributed, used for commercial purposes or given to others either in full or in part without the consent of Binks PCE.

We reserve the right to alter drawings and specifications necessary for the technical improvement of this product without notice.



**Equipment Misuse Hazard**

Equipment misuse can cause the equipment to rupture or malfunction and result in serious injury.

- This equipment is for professional use only.
- Read all instruction manuals, tags, and labels before operating the equipment.
- Use the equipment only for its intended purpose.
- Do not alter or modify this equipment. Use only genuine Binks PCE parts and accessories.
- Check equipment daily. Repair or replace worn or damaged parts immediately.
- Do not exceed the maximum working pressure stated on the equipment or in the Technical Data for your equipment. Do not exceed the maximum working pressure of the lowest rated component in your system.
- Use fluids and solvents which are compatible with the equipment wetted parts. Refer to the Technical Data section of all equipment manuals. Read the fluid and solvent manufacturer's warnings.
- Route hoses away from traffic areas, sharp edges, moving parts, and hot surfaces. Do not expose hoses to temperatures above 82°C (180°F) or below -40°C (-40°F).
- Do not lift pressurized equipment.
- Comply with all applicable local, state, and national fire, electrical, and safety regulations.



**Fire, Explosion and Electric Shock Hazard**

Improper grounding, poor ventilation, open flames or sparks can cause a hazardous condition and result in a fire, explosion, or electric shock.

When installed and operated in accordance with its instructions, the pump is approved for operation in Zone 1 (Europe) & Division 1 (North America), hazardous locations. (ATEX Cat 2)

- Electrical equipment must be installed, operated, and serviced only by trained, qualified personnel who fully understand the requirements stated in this instruction manual.
- Ground the equipment and all other electrically conductive objects in the spray area. After grounding test with ohmmeter to ensure earth continuity is 1 ohm or less.
- Keep all covers tight while the motor is energized.
- If there is any static sparking or you feel an electric shock while using this equipment, stop spraying/dispensing immediately. Do not use the equipment until you identify and correct the problem.
- Provide fresh air ventilation to avoid the build up of flammable fumes from solvents or the fluid being pumped.
- Keep the pumping area free of debris, including solvent, rags, and gasoline.
- Electrically disconnect all equipment in the pumping area.
- Extinguish all open flames or pilot lights in the spray/dispense area.
- Do not smoke in the spray/dispense area.
- Do not turn on or off any light switch in the spray/dispense area while operating or if fumes are present.





# WARNING



**READ THE MANUAL**

Before operating equipment, read and understand all safety, operation and maintenance information provided in the operation manual.



**DE-ENERGIZE, DEPRESSURIZE, DISCONNECT AND LOCK OUT ALL POWER SOURCES DURING MAINTENANCE**

Failure to De-energize, disconnect and lock out all power supplies before performing equipment maintenance could cause serious injury or death.



**OPERATOR TRAINING**

All personnel must be trained before operating equipment.



**KEEP EQUIPMENT GUARDS IN PLACE**

Do not operate the equipment if the safety devices have been removed.

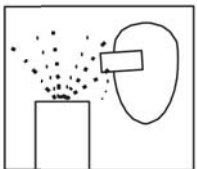

**PROJECTILE HAZARD**

You may be injured by venting liquids or gases that are released under pressure, or flying debris.



**PINCH POINT HAZARD**

Moving parts can crush and cut. Pinch points are basically any areas where there are moving parts.



**MAGNETIC FIELD PRESENT**

You may be subjected to magnetic fields which may interfere with the operation of certain pacemakers.



**WEAR SAFETY GLASSES**

Failure to wear safety glasses with side shields could result in serious eye injury or blindness.



**NOISE HAZARD**

You may be injured by loud noise. Hearing protection may be required when using this equipment.



**KNOW WHERE AND HOW TO SHUT OFF THE EQUIPMENT IN CASE OF AN EMERGENCY**



**HIGH PRESSURE CONSIDERATION**

High pressure can cause serious injury. Relieve all pressure before servicing. Hose leaks, or ruptured components can inject fluid into your body and cause extremely serious injury.



**AUTOMATIC EQUIPMENT**

Automatic equipment may start suddenly without warning.

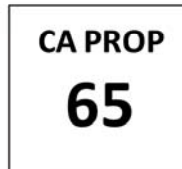

**PROP 65 WARNING**

WARNING: This product contains chemicals known to the State of California to cause cancer and birth defects or other reproductive harm.



**MAGNET HAZARD**

Take care when handling magnets. Avoid getting magnets in close proximity of each other. Injury or damage to magnets may result.



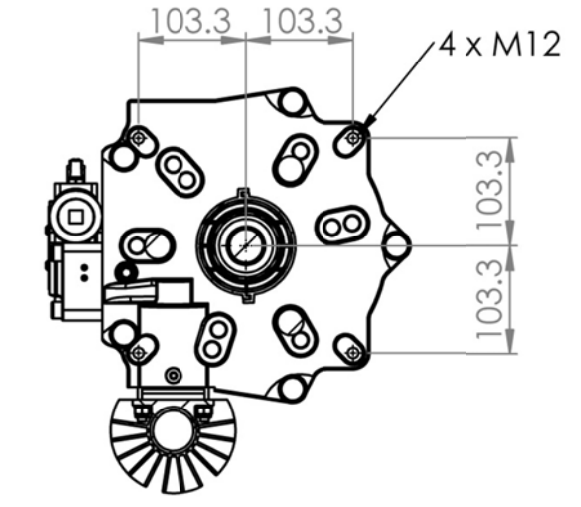
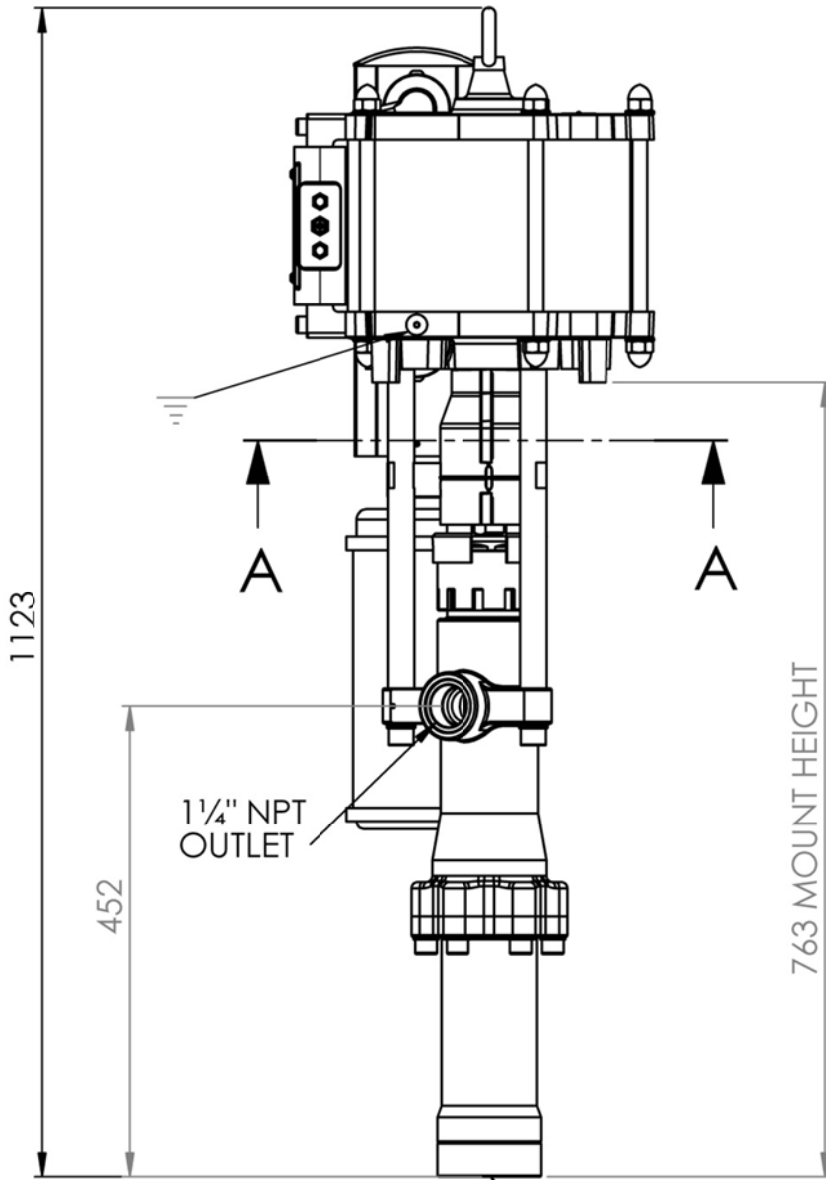

SECTION A-A  
MOUNTING DETAIL

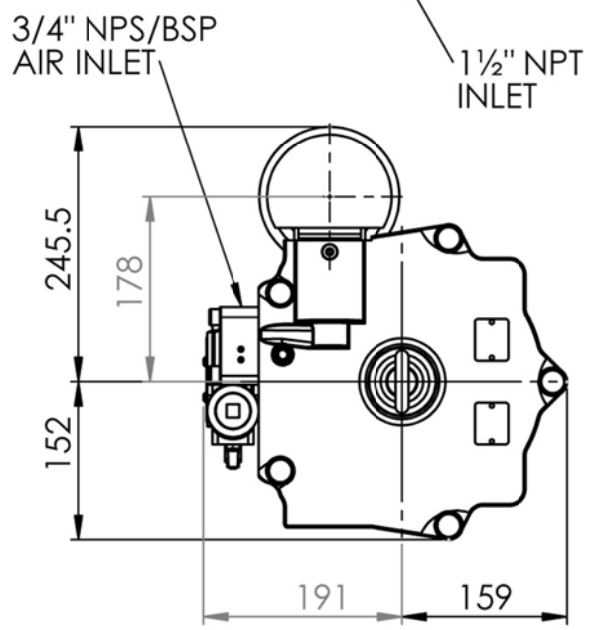

## ***General Description***

The MX44030PU-XXX fluid paint pump is designed for pumping High Viscosity materials such as Mastic, PVC, Underseals, Sound deadeners and other similar materials.

The fluid section is a 'ROD' type design which means the rod displaces the material and is the only wear contact with the packings. A two-ball check valve system ensures precise, smooth volume output. Tungsten Carbide ball seats ensure maximum operating life between servicing.

The interior design maintains high flow capacity with minimum pressure drop ensuring high efficiency; special surface treatments provide a smooth micro surface making cleaning and flushing easier.

The piston and rod seals are the chevron type, which can be adjusted by means of a gland nut, should wear occur, a preloaded wave spring is employed to adjust and maintain the lower chevron packing preload when wear occurs. A built in Solvent cup cleans and lubricates the pump rod and seals to prolong working life.

The air motor also utilises the Binks quick exhaust technology to prevent air valve freezing conditions when high cycle speeds are employed.

The air motor is furnished with an exhaust muffler to control air exhaust noise emission. An adapter kit is also available to facilitate connection to a piped exhaust system if required.

## ***Installation***

*This pump should be flushed with a suitable compatible solvent prior to use.*

It is recommended that a propriety 1/2" BSP Filter / Regulator is used to provide final control of the compressed air to the air motor.

Mount the pump securely and position the pump at a convenient height to allow for maintenance, visual observation, and periodic inspection.



The Pump Assembly must be connected to a suitable earth ground to ensure that there is no possibility of static build up.

Attach suitable pipework or flexible hoses designed to meet the working pressure of the pump assembly (dependent on pump ratio) to the inlet and outlet connections, e.g. 1½" Inlet and 1¼" Outlet.

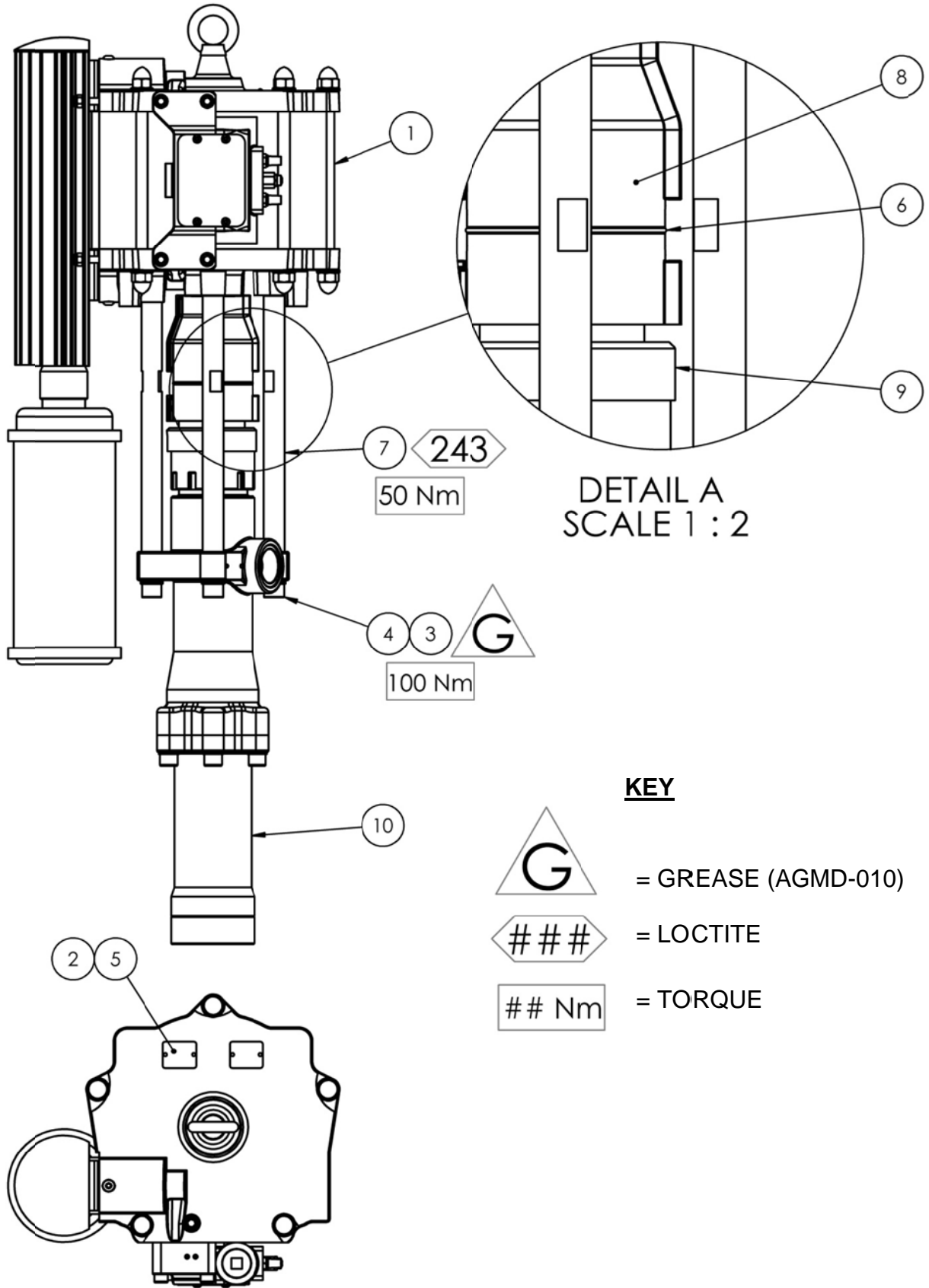
Set the pump speed to a slow cycle rate and start the pump to remove any air from the fluid circuit. Inspect for any air or fluid leaks.

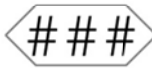

**KEY**

-  = GREASE (AGMD-010)
-  = LOCTITE
-  = TORQUE



| <b>Parts List – ‘MX44030PU-CMH/SMH Pump Assembly’</b> |                |                           |            |                |
|---|----------------|---------------------------|------------|----------------|
| <b>ITEM</b>   | <b>PART No</b> | <b>DESCRIPTION</b>        | <b>QTY</b> | <b>REMARKS</b> |
| 1   | 104037         | A260 AIR MOTOR            | 1          |                |
| 2   | 164838         | RIVET                     | 2          |                |
| 3   | 165100         | M16 SPRING WASHER         | 3          |                |
| 4   | 165594         | M16 x 60 SOCKET CAPSCREW  | 3          |                |
| 5   | 193540         | LABEL                     | 1          |                |
| 6   | 193543         | COVER CLIP                | 1          |                |
| 7   | 193616         | TIE ROD                   | 3          |                |
| 8   | 193938         | FX440 HAND GUARD          | 2          |                |
| 9   | 193940         | FX440 GUARD ADAPTOR       | 1          |                |
| 10  | FX440PU-CMH    | FX440PU-CMH FLUID SECTION | 1          |                |
| 10  | FX440PU-SMH    | FX440PU-SMH FLUID SECTION | 1          |                |

| <b>Replacement Spares Kits</b>   |                 |                             |   |
|--|-----------------|-----------------------------|---|
| <b>No.</b>   | <b>Part No.</b> | <b>Description</b>          | <b>Remarks</b>  |
| 1  | 250645          | Air Motor Overhaul Kit      | Air Piston Seal<br>Shaft seals and bearing<br>All O-rings<br>QEV cups<br>Pilot Valves inc O-rings |
| 2  | 250647          | Air Motor Control Valve Kit | Main Spool Valve inc. O-rings   |
| 3  | 250696          | Fluid Section Seal Kit      | All O-rings<br>All Packings   |
| <p>Check Main Parts List in Air Motor &amp; Fluid Section Manuals for details of individual Kit Contents</p> |                 |                             |   |

| Pump Accessories |   |                                  |
|------------------|---|----------------------------------|
| PART No          | DESCRIPTION                                   | REMARKS                          |
| 192506           | Exhaust Tube Adapter<br>(1½" NB hose)         | For piped exhaust                |
| 0114-014178      | Earth Wire                                    |                                  |
| MXA-C13ALM5-H34  | Air Control Including Hose                    | Air Filter Regulator (0.5m Hose) |
| AGMD-010         | Kluber Isoflex Topas NB 52<br>(Grease type #) | 50 ml Tube                       |
|                  |   |                                  |
|                  |   |                                  |
|                  |   |                                  |

| Preventative Maintenance  |
|---|
| <p><b>Check daily</b> to ensure that there is the correct type of lubricant material present in the solvent cup; this should be compatible with the material being pumped. Confirmation from the material supplier should be sought to ensure compatibility to prevent the risk of contamination.</p> <p><b>Check daily</b> for excessive material leaks into the solvent cup</p> <p>A universal lubricant is available - Wet Sol 'Plus' Binks Part Number 863009</p> |

| <b>Fault Finding</b>  |  |   |
|---|--|---|
| <b>Symptom</b>  | <b>Possible Cause</b>  | <b>Remedy</b>   |
| Motor will not run  | <ul style="list-style-type: none"> <li>a. No Air supply</li> <li>b. Air piston seal worn.</li> <li>c. Pilot valve assemblies inoperable.</li> <li>d. Main air valve inoperable</li> <li>e. QE valve defective</li> </ul> | <ul style="list-style-type: none"> <li>a. Check air and fluid supply ball valves and supply hoses.</li> <li>b. Replace Piston seal</li> <li>c. Switch/interchange pilot valves to isolate faulty pilot valve and clean/replace.</li> <li>d. Check clean/replace Air valve.</li> <li>e. Check for constant exhaust air when pump is not in a stalled condition. Check/replace QE cups</li> </ul> |
| Pump runs but has excessive pulsation   | <ul style="list-style-type: none"> <li>a. Worn piston seal.</li> <li>b. Worn/failed shaft seals.</li> <li>c. Damaged Exhaust Valve</li> <li>d. Damaged Pilot Valve</li> <li>e. Air exhaust restricted.</li> </ul>        | <ul style="list-style-type: none"> <li>a. Replace seal</li> <li>b. Replace shaft bearing / seal housing.</li> <li>c. Inspect / clean and replace as required</li> <li>d. Inspect / clean and replace as required</li> <li>e. Inspect / clean and replace as required</li> </ul>   |
| Leak from rod seal packings   | Seal wear or damage to packing material  | Stop the pump and relieve all material pressure. Tighten the gland nut until the resistance of the packings clamping the shaft can be felt. Do not over-tighten. Ensure solvent cup has the correct lubricant for the material being pumped present at all times.   |
|   | Damaged rod  | Replace   |
| Low material flowrate, pump running fast or will not stall (stalling - 1 stroke should not occur in less than 30 seconds) | Contaminates trapped between ball and seat   | Strip and clean pump.<br>Check for damage   |
|   | Worn or damaged balls/seats  | Check for wear; replace balls and / or seats.   |
|   | Worn bottom rod seals  | Replace   |
| Air entering system   | Loose joint on suction side  | Check and reseal fittings   |



Justus-von-Liebig-Straße 31, 63128 Dietzenbach. DE  
Tel. +49 (0) 6074 403 1 Fax. +49 (0) 607 403 300  
General e-mail: [info@finishingbrands.eu](mailto:info@finishingbrands.eu)

Ringwood Road, Bournemouth, Dorset BH11 9LH. UK  
Tel. +44 (0)1202 571 111 Fax. +44 (0)1202 573 488  
General e-mail: [info@finishingbrands.eu](mailto:info@finishingbrands.eu)

163-171, Av. des Auréats, 26014 Valence cedex. FR  
Téléphone : +33 (0) 4 75 75 27 53 Télécopie: +33 (0) 4 75 75 27 79  
General e-mail: [info@finishingbrands.eu](mailto:info@finishingbrands.eu)

**USA Canada Customer Service**

195 Internationale Blvd.  
Glendale Height, IL 60139  
630-237-5000

Toll Free Customer Service and  
Technical Support 800-992-4657  
Toll Free Facsimile 800-246-5732