

BINKS[®]

Maple 20AFP Pump

Model 104016

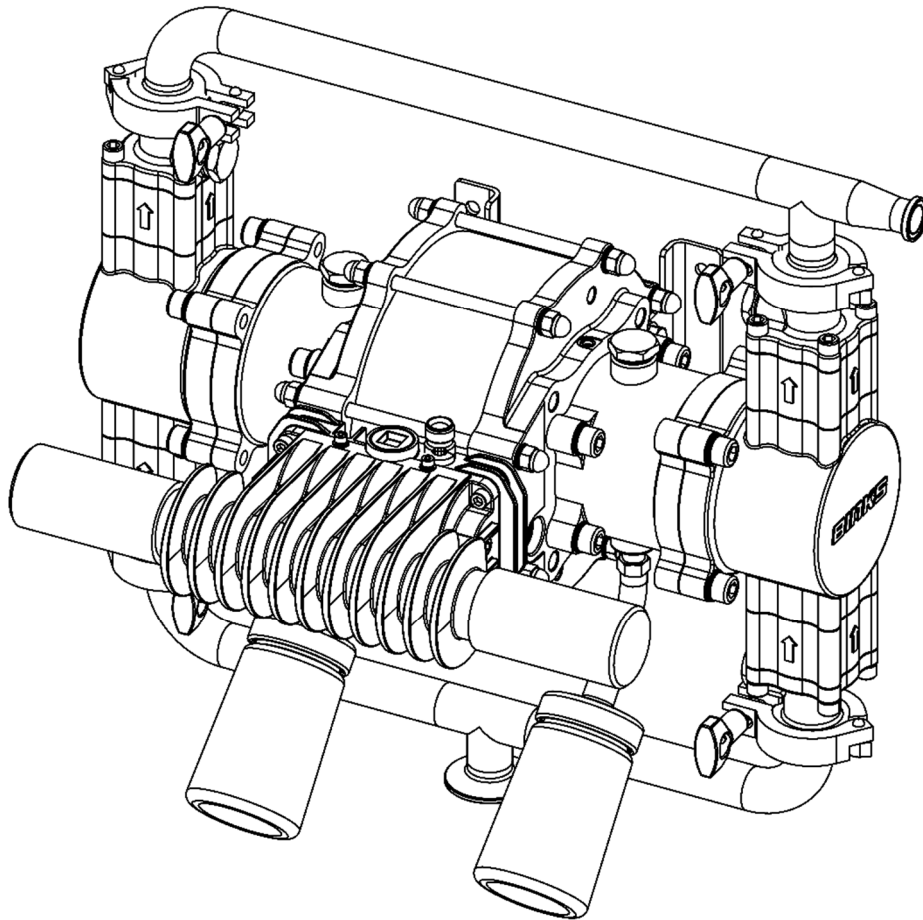

IMPORTANT! DO NOT DESTROY

It is the Customer's responsibility to have all operators and service personnel read and understand this manual.

Contact your local Carlisle Fluid Technologies representative for additional copies of this manual.

READ ALL INSTRUCTIONS BEFORE OPERATING THIS PRODUCT

Product Description	Pumps - Maple, DVP, 104009, 104010, 104016, 104027, 104032, 104077, 104025, 104023, 104028, 106933,
This Product is designed for use with:	Solvent and Water based Materials
Suitable for use in hazardous area:	Zone 1 & 2
Protection Level:	II 2 G X IIB T4
Manufacturer:	Binks, Ringwood Road, Bournemouth, BH11 9LH. UK

EU Declaration of Conformity



We: Binks declare that the above product conforms with the Provisions of:

Machinery Directive 2006/42/EC

ATEX Directive 94/9/EC

by complying with the following statutory documents and harmonized standards:

EN ISO 12100: Safety of Machinery - General Principles for Design

EN ISO 4413: Hydraulic Fluid Power - General Rules and safety requirements

EN ISO 4414: Pneumatic Fluid Power - General Rules and safety requirements

EN 12621: Machinery for the supply and circulation of coating materials under pressure - Safety requirements

EN1127-1: Explosive atmospheres - Explosion prevention - Basic concepts

EN 13463-1: Non electrical equipment for use in potentially explosive atmospheres - Basic methods and requirements

EN 13463-5: Non electrical equipment for use in potentially explosive atmospheres - Protection by constructional safety

Providing all conditions of safe use stated within the product manuals have been complied with and that the final equipment into which this product is installed has been re-assessed as required, in accordance with essential health and safety requirements of the above standards, directives and statutory instruments and also installed in accordance with any applicable local codes of practice.

D Smith (General Manager)
1/11/12

Index

Section

- 1.1 General Description
- 1.2 Operating Principle
- 1.3 Specifications
- 1.4 Dimensions and Mounting Details

- 2.1 Important Safety Information

- 3.1 Installation - General

- 4.1 Parts Lists Main Pump
- 4.2 Parts Lists Air Motor
- 4.3 Parts Lists Fluid Section
- 4.4 Parts Lists Reference

- 5.1 Maintenance – Air Motor Assembly Procedure
- 5.2 Maintenance – Fluid Section/Air Motor Assembly
- 5.3 Maintenance – Final Pump Assembly

- 6.1 Maintenance - General
- 6.2 Maintenance - Fault Finding

- 7.1 Spare Parts Lists
- 7.2 Accessories

General Description – Section 1.1

High Quality materials and surface treatments are used in the construction of this pump to ensure both extended operational life and good future appearance.

The Maple pump is a horizontal piston pump for pumping Solvent / Waterborne Paints, Solvents and other suitable materials.

This pump is used primarily on Piggable paint systems due to the quickly flushable fluid section.

An Ø180 x 40mm stroke air motor is used to drive two fluid sections giving a combined output of 0.475 L per cycle.

The unit combines an energy efficient air motor with low shear fluid section technology from the range of Smart Electric Pumps.

The Maple Pump achieves a reciprocating drive by using high technology ground and lapped steel spool and sleeve air valves to control the air motor reversal, providing reciprocating motion.

The air motor also utilises the Binks Low Ice quick exhaust technology to prevent air valve freezing conditions when high cycle speeds are employed.

Equal thrust on each stroke due to the horizontal configuration incorporating the dual piston rod design gives a balanced fluid pressure output and reduces fluid pressure fluctuations to a minimum.

The air pump is furnished with twin exhaust mufflers to control exhaust noise emission. An adapter kit is available to facilitate connection to a piped exhaust system if required.

A 1/8" Port is incorporated into the main air valve to facilitate an optional cycle counter.

Complies with current relevant European and US Legislation

Operating Principle – Section 1.2

The Assembly comprises of:-

- Central Air Piston and ‘change over’ Poppet valves
- 2 off Quick Exhaust and muffler assembly
- 2 off Dynamic Chambers and Fluid Pistons
- 2 off Fluid Pressure Chambers each complete with Suction and Pressure Ball Check Valve Assemblies
- 1 off Fluid Inlet Manifold
- 1 off Fluid Outlet Manifold
- Support Bracket

The Pumps have horizontally opposed positive displacement pistons connected to a common reciprocating air motor piston. The pneumatically driven piston actuates poppets I valves at the end of its travel producing an air logic signal to shuttle the spool valve initiating the opposite stroke.

The main spool valve is air piloted and contains two exhaust ports. Both the poppet valves and the main spool valve are easily removable.

There are no external air pilot hoses. The air logic and exhaust ports are internal. Simply mounting the spool valve and the poppet valves assures that the logic circuits are connected properly.

The air cylinder exhaust air is channelled through two independent quick exhaust valves to minimise piston reversal time.

The “4-Ball” fluid section design refers to the two sets of ball checks. Each fluid chamber has an inlet and outlet ball check, these are connected by a common inlet manifold and outlet manifold respectively.

A bellows provides piston shaft protection, whilst a main piston seal maintains the pump fluid pressure within the pressure chamber.

When the main piston seal starts to pass fluid due to wear, any leakage passes into the dynamic chamber and into the indicator bottle.

Specification – Section 1.3

Specification	
Pump Nominal Stroke	40 mm 1.57 ins
Pump Ratio	4.2:1
Nominal Flow Volume / Cycle	0.475 Litres 0.125 US Gall
Fluid Output @ 60 cycles/min	28.4 Litres / min 7.5 US Gall / min
Maximum Recommended Continuous Cycle Rate Maximum Recommended Intermittent Cycle Rate	20 Cycles /min 40 Cycles /min
Fluid Inlet Connections Fluid Outlet Connection	1" Sanitary ¾" Sanitary
Air Volume / cycle	0.33 SCFM (9.5 L/m) @ 45PSI (3.1 Bar) 0.65 SCFM (18.5 L/m) @ 90 PSI (6.2 Bar)
Air Flow @ 15 cycles/min 6 bar Air Flow @ 30 cycles/min 6 bar	10 CFM (283 L/min) 20 CFM (566 L/min)
Air Quality ISO 8573.1 Class 3.3.2 # See Note	Dirt 5 microns Water -20°C@7bar (940ppm) Oil 0.1mg/m ³
Total Weight of Pump	30 Kg 66 Lb
<p># Note: Class 3.4.2 Air Quality (Refrigerant dried - water +3°C@7bar) may be used, however, above 15 cycles/min optional heavy duty mufflers 192821 or piped exhaust system should be used.</p>	

Dimensions and Mounting Details – Section 1.4

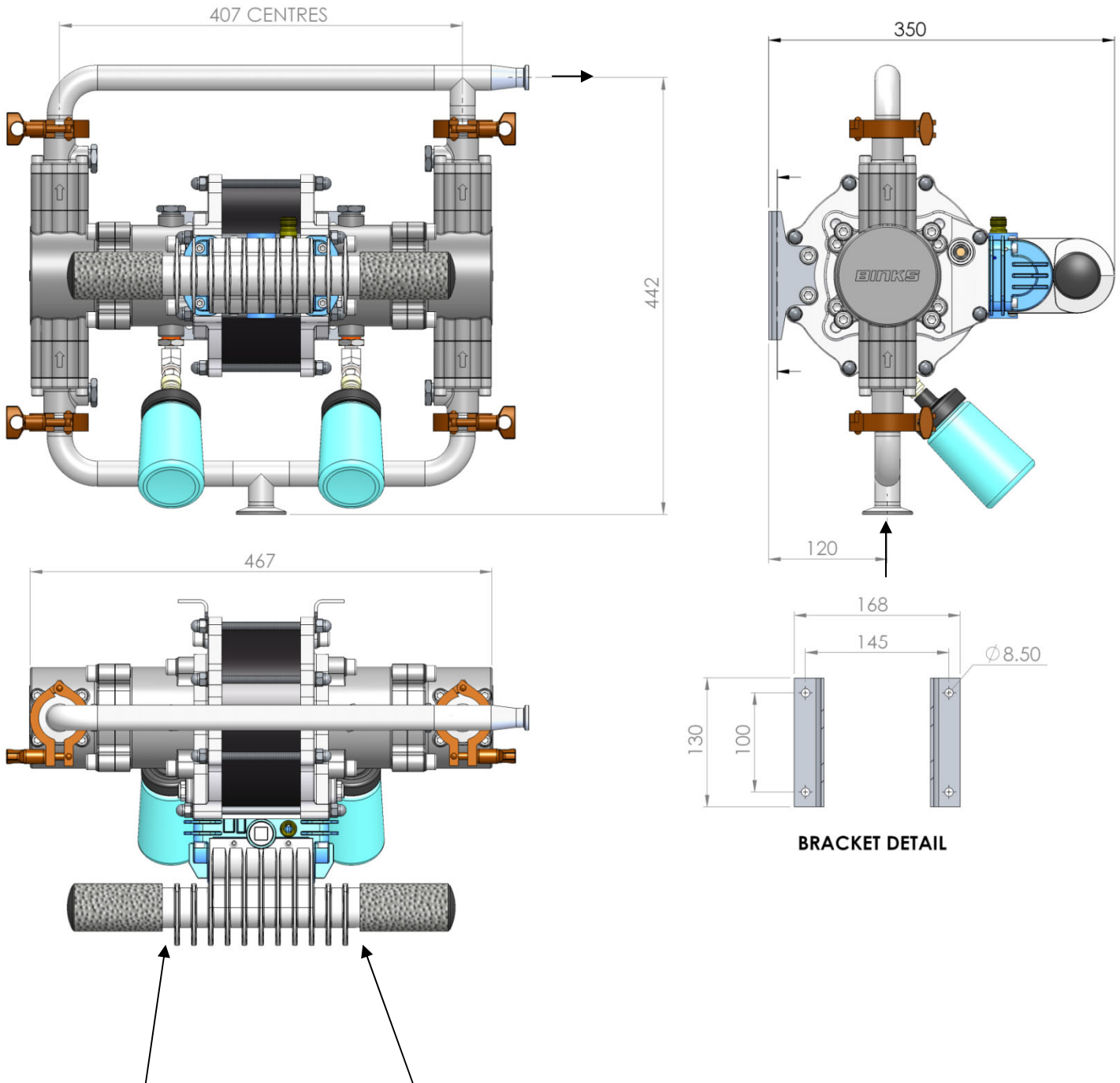

For Piped Exhaust Air, remove mufflers and add 192803 Plug and Hose Adapter 192779 for 1" NB Hose or 192820 for 1 ¼" NB Hose.
 Note: For Pump fluid pressures above 13 bar use 1 ¼" NB

Important Safety Information - Section 2.1

Directions for Working Safety

This Product has been constructed according to advanced technological standards and is operationally reliable. Damage may, however, result if it is used incorrectly by untrained persons or used for purposes other than those for which it was constructed.

The locally current regulations for safety and prevention of accidents are valid for the operation of this product under all circumstances.

International, national and company safety regulations are to be observed for the installation and operation of this product, as well as the procedures involved in maintenance, repairs and cleaning.

These instructions are intended to be read, understood and observed in all points by those responsible for this product. These operating and maintenance instructions are intended to ensure trouble free operation. Therefore, it is recommended to read these instructions carefully before start-up. Binks cannot be held responsible for damage or malfunctions resulting from the non-observance of the operating instructions. These instructions including regulations and technical drawings may not be copied, distributed, used for commercial purposes or given to others either in full or in part without the consent of Binks. We reserve the right to alter drawings and specifications necessary for the technical improvement of this product without notice.

High Pressure/Electrostatic Warning

High pressure equipment can be dangerous if used incorrectly, serious bodily injury may occur if the following instructions are ignored. Installation and maintenance should only be carried out by suitably qualified personnel.

1. Before attempting any work on a high-pressure system ensure material pump, hydraulics, compressed air motor are isolated where relevant.
2. Relieve all pressure from the system. Note: It is possible for pressure to get locked into a system, therefore, ensure all sections of the system are checked thoroughly for remaining pressure.
3. Take care when releasing fittings
4. Always replace worn hoses immediately
5. Never plug a leak with your finger, adhesive tape or other stop gap devices

Always ensure equipment is suitably earthed before running, to avoid any chance of electrostatic build up.

Equipment Misuse Hazard

Equipment misuse can cause the equipment to rupture or malfunction and result in serious injury.

- This equipment is for professional use only.
- Read all instruction manuals, tags, and labels before operating the equipment.
- Use the equipment only for its intended purpose.
- Do not alter or modify this equipment. Use only genuine Binks parts and accessories.
- Check equipment daily. Repair or replace worn or damaged parts immediately.
- Do not exceed the maximum working pressure stated on the equipment or in the Technical Data for your equipment. Do not exceed the maximum working pressure of the lowest rated component in your system.
- Use fluids and solvents which are compatible with the equipment wetted parts. Refer to the Technical Data section of all equipment manuals. Read the fluid and solvent manufacturer's warnings.
- Route hoses away from traffic areas, sharp edges, moving parts, and hot surfaces. Do not expose hoses to temperatures above 82°C (180°F) or below -40°C (-40°F).
- Wear hearing protection when operating this equipment.
- Do not lift pressurized equipment.
- Comply with all applicable local, state, and national fire, electrical, and safety regulations.

Important Safety Information - Section 2.1

Fire, Explosion and Electric Shock Hazard

Improper grounding, poor ventilation, open flames or sparks can cause a hazardous condition and result in a fire, explosion, or electric shock.

When installed and operated in accordance with its instructions, the pump is approved for operation in Zone 1 (Europe) & Division 1 (North America), hazardous locations. (ATEX Cat 2)

- Electrical equipment must be installed, operated, and serviced only by trained, qualified personnel who fully understand the requirements stated in this instruction manual.
- Ground the equipment and all other electrically conductive objects in the spray area. After grounding test with ohmmeter to ensure earth continuity is 1 ohm or less.
- Keep all covers tight while the motor is energized.
- If there is any static sparking or you feel an electric shock while using this equipment, stop spraying/dispensing immediately. Do not use the equipment until you identify and correct the problem.
- Provide fresh air ventilation to avoid the build-up of flammable fumes from solvents or the fluid being pumped.
- Keep the pumping area free of debris, including solvent, rags, and gasoline.
- Electrically disconnect all equipment in the pumping area.
- Extinguish all open flames or pilot lights in the spray/dispense area.
- Do not smoke in the spray/dispense area.
- Do not turn on or off any light switch in the spray/dispense area while operating or if fumes are present.
- Do not operate a gasoline engine in the spray/dispense area.

Hot Surface Hazard

- The electric motor becomes hot during operation, and the heat may be transferred to other connected equipment. To reduce the risk of burning yourself, do not touch the motor surfaces while it is operating. Before servicing, allow the motor to cool.
- Keep flammable materials and debris away from the equipment.

Pressurized Equipment Hazard

Spray from the gun/valve, hose leaks, or ruptured components can splash fluid in the eyes or on the skin and cause serious injury.

- Do not point the gun/valve at anyone or at any part of the body.
- Do not stop or deflect leaks with your hand, body, glove or rag.
- Spraying/dispensing; clean, check, or service the equipment.
- Tighten all fluid connections before operating the equipment.
- Check the hoses, tubes, and couplings daily. Replace worn, damaged, or loose parts immediately. Permanently coupled hoses cannot be repaired; replace the entire hose.

Toxic Fluid Hazard

Hazardous fluid or toxic fumes can cause serious injury or death if splashed in the eyes or on the skin, inhaled, or swallowed.

- Know the specific hazards of the fluid you are using.
- Store hazardous fluid in an approved container. Dispose of hazardous fluid according to all local, state and national guidelines.
- Always wear protective eyewear, gloves, clothing and respirator as recommended by the fluid and solvent manufacturer.

Moving Parts Hazard

- Keep clear of all moving parts when starting or operating the pump.

Installation – Section 3.1

Mount the pump securely and position the pump at a convenient height (below the lid height of the paint container), to allow for maintenance, visual observation, and periodic inspection.

The wall mount bracket is included with all pumps.

Exhaust silencer kits are available for these pumps if the air exhaust is required to be piped away from the pump rather than exhausting locally through the mufflers.

The Pump Mounting Frame must be connected to a suitable earth ground to ensure that there is no possibility of static build up.

Attach a suitable flexible hose (20 bar working pressure) to the inlet connection. The Outlet connection is normally direct connected to ¾" Piggable pipework system.

Connect a suitable 3/8 NB air hose and ½" Pressure Filter Regulator to the air motor. (Filter rated at minimum 1000 L/min)

No additional air lubrication is required as piston o-ring lubricant is applied during assembly or repair. If an air lubricator is used to prolong piston seal life (for example continuous duty at high pump cycle rates) then this must be maintained as the lubricant removes the piston seal assembly grease.

Set the pump speed to a slow cycle rate and start the pump to remove any air from the fluid circuit. Inspect for any air or fluid leaks.

Set the pump cycle rate to achieve the required paint volume and then adjust the system back pressure regulator and pump air pressure to achieve the desired system fluid pressure.

A Back Pressure Regulator should be mounted in the paint system return line. The return line 'back pressure' regulator responds to the changes in system fluid flow demand, (due to variable paint usage) by dynamically adjusting the paint flow rate returning to the system paint tank, thus maintaining the set pressure.

The indicator bottles are provided to show when the fluid seals require to be replaced. Note a new seal may allow a small amount of paint into the cup during the 'bedding in' process

Parts List – Section 4.1

Parts List - 104016 Main Pump Assembly				
ITEM	PART No	DESCRIPTION	QTY	REMARKS
1	-----	AIR MOTOR ASSEMBLY	1	
2	-----	FLUID SECTION ASSEMBLY	2	
81	192777	MUFFLER	2	
82	192845	INLET MANIFOLD	1	
83	192846	OUTLET MANIFOLD	1	
84	192009	SANITARY CLAMP	4	
85	192206	SANITARY GASKET	4	①
86	207-12333	BOTTLE	2	
87	193680	¼ NIPPLE	4	
88	193681	¼ ELBOW	2	

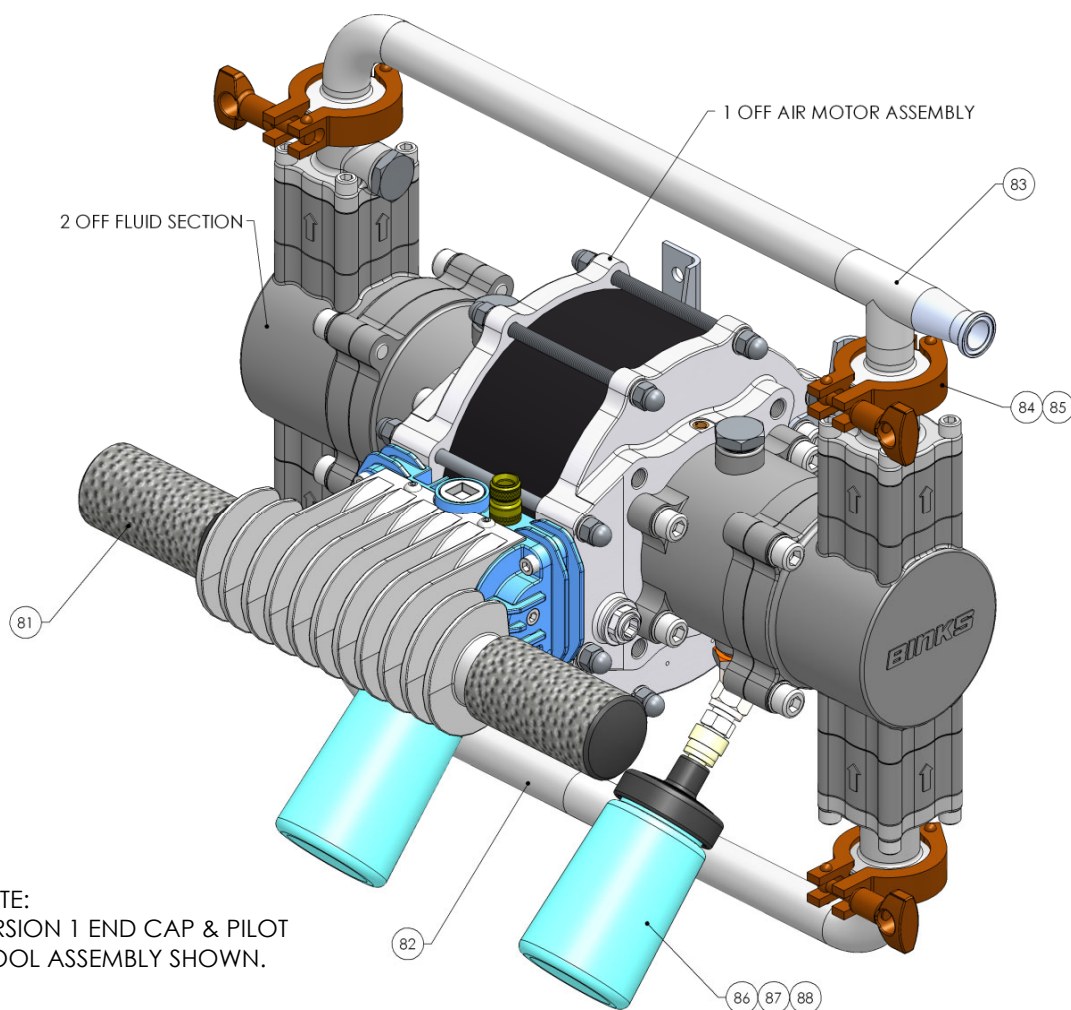

Parts List - Air Motor Assembly				
ITEM	PART No	DESCRIPTION	QTY	REMARKS
3	0115-010102	MAIN AIR VALVE ASSEMBLY	1	
4	161992	Ø177.5 x 2.62 VITON O-RING	2	③
5	161993	Ø20.35 x 1.78 VITON O-RING	2	③
6	161994	Ø4.47 x 1.78 O-RING	4	③
7	161995	Ø19.5 x 3.00 O-RING	2	③
8	162702	PISTON SEAL	1	③
9	162703	SHAFT SEAL	2	③
10	162704	SHAFT BEARING	2	③
11	163920	M6 x 30 CAP HD SCREW (ST ST)	4	
12	165108	M8 SPRING WASHER (ST ST)	16	
13	165135	M10 PLAIN WASHER (ST ST)	4	
14	165528	M4 x 16 CAPHEAD SET SCREW (ST ST)	4	
15	165963	M8 HEX NUT	16	
16	165964	M12 x 40 GRUBSCREW (ST ST)	1	
17	165965	M10 x 16 HEX HEAD SET SCREW (ST ST)	4	
18	165970	M4 PLAIN WASHER (ST ST)	4	
19	165971	Ø4 SPRING WASHER (ST ST)	4	
20	192374	RETAINING NUT	2	
21	192579	KNIFED BELLOWS	2	①
22	-----	-----	--	
23	192757	CYLINDER	1	
24	192758	END PLATE	2	
25	192841	PISTON SHAFT	2	
26	192842	PISTON	1	
27	192761	CYLINDER STUD	6	
28	192762	CYLINDER STUD (LONG)	2	
29	192843	BELLOWS SPACER	2	
30	192764	PUMP BRACKET	2	
31	192765	PILOT SPOOL ASSEMBLY	2	④
	0115-010037	POPPET ASSEMBLY		
32	192799	VENT PLUG	4	
33	192812	EXHAUST ADAPTER	1	

Parts List – Section 4.2

Air Motor Assembly

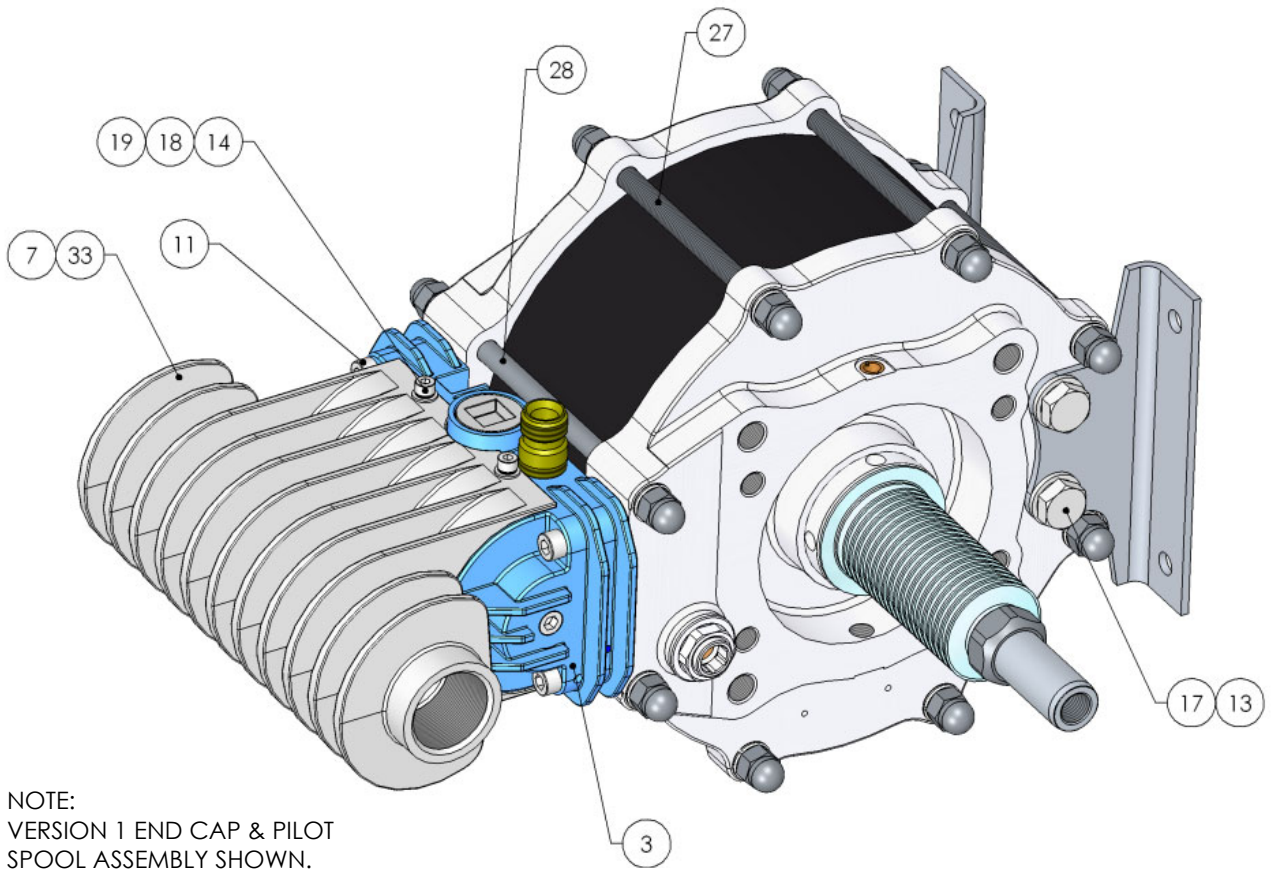

NOTE:
VERSION 1 END CAP & PILOT
SPOOL ASSEMBLY SHOWN.

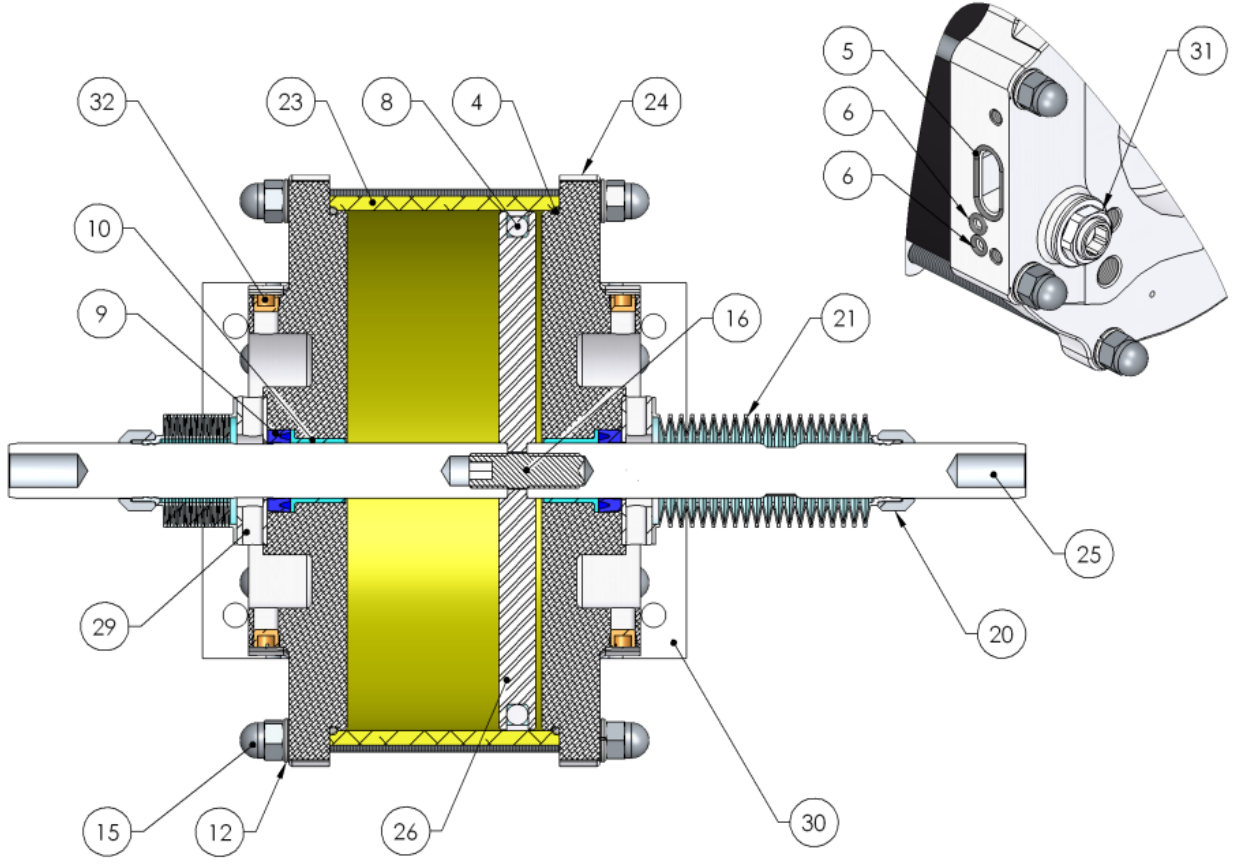

Parts List – Section 4.2

Parts List - 0115-010102 Main Air Valve Assembly				
ITEM	PART No	DESCRIPTION	QTY	REMARKS
40	0115-010097	VALVE BLOCK ASSEMBLY	1	
41	0115-010015	SPOOL & SLEEVE ASSEMBLY	1	④
42	0115-010016	BUMPER	2	④
43	0115-010017	MAGNET	2	④
44	0115-010018	END CAP	2	
45	192813	QE VALVE CAGE	2	
46	0115-010020	QEV DIAPHRAGM	2	③
47	0115-010021	Ø36 x 1.5 O-RING	2	③
48	0115-010049	Ø20 x 2 O-RING	2	④
49	0115-010073	M4 x 12 BUTTON HD CAP SCREW	8	
50	171612	1/8" PLUG	1	
51	171621	1/4 " PLUG	1	
52	180584	AIR INLET FITTING (3/8")	1	

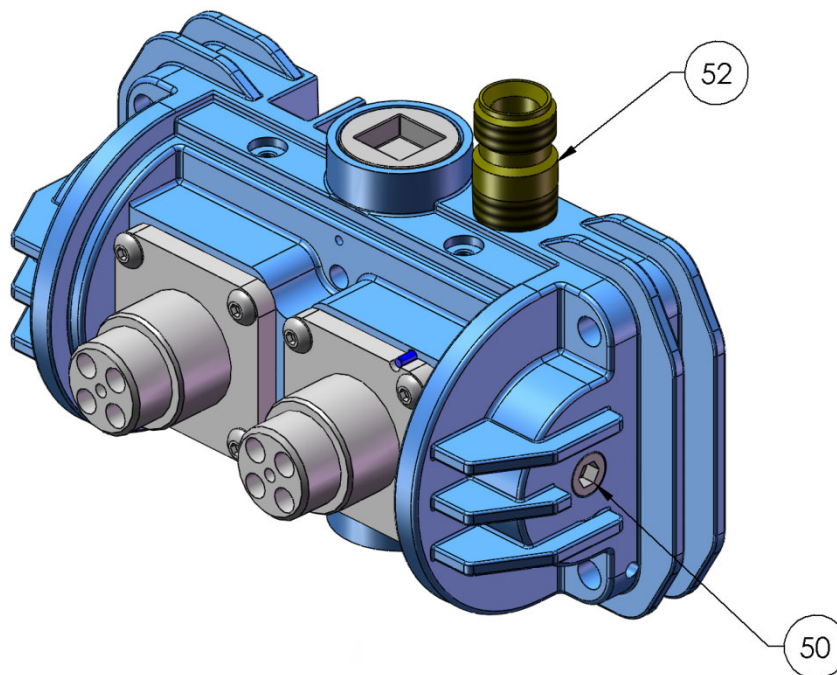

Parts List – Section 4.2

0115-010102 Main Air Valve Assembly

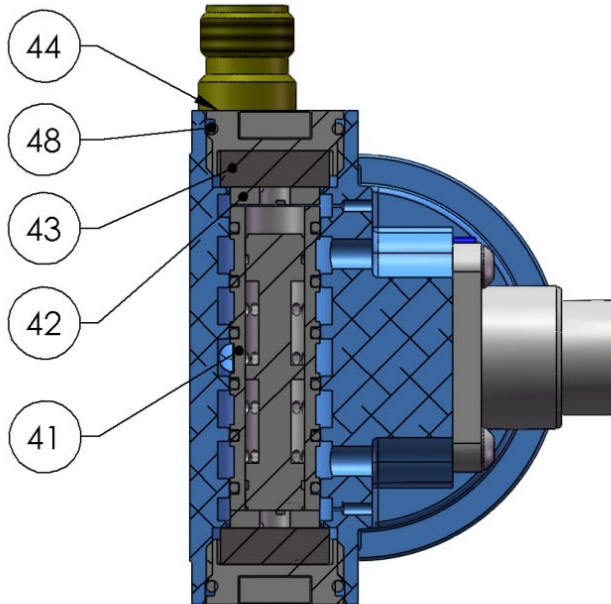

SPOOL DETAIL

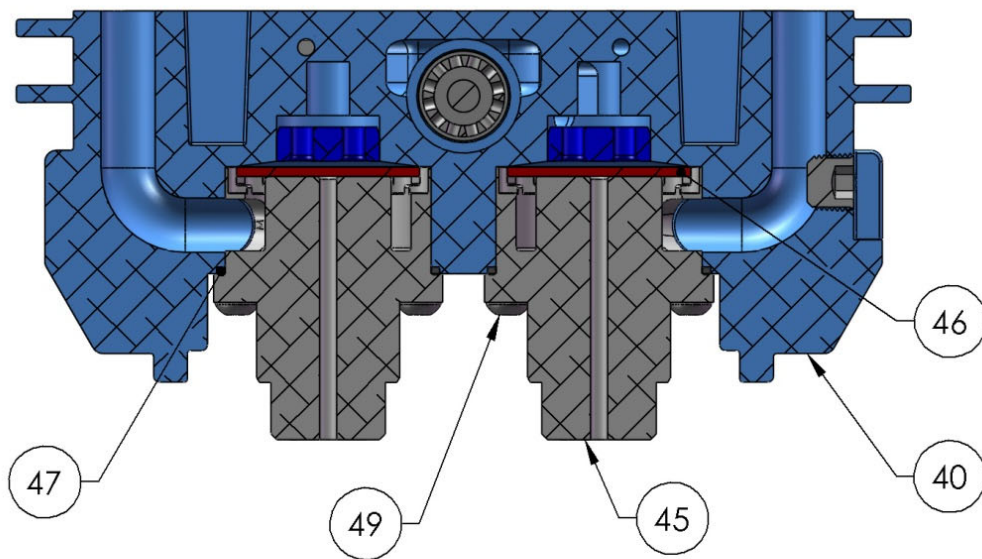

QUICK EXHAUST DETAIL

Parts List – Section 4.3

Parts List – Fluid Section				
ITEM	PART No	DESCRIPTION	QTY	REMARKS
55	192376	CERAMIC PISTON	1	
56	192717	DYNAMIC CHAMBER	1	
57	192378	PISTON SEAL	1	❶
58	192844	OUTLET BLOCK	1	
59	41-4404	BALL CAGE	2	
60	41-4405	FLANGE ADAPTER	2	
61	41-4416	SEALING WASHER	4	❶
62	41-4418	PLUG	3	
63	41-4427	DRAIN ADAPTER	1	
64	165123	M10 SPRING WASHER	8	
65	165947	M10 x 35 CAP HD SCREW	8	
66	237-702	5/16 – 18 x 2.25 CAP HD SCREW	8	
67	192833	SEAT	2	
68	192382	Ø 25.4 BALL	2	
69	192712	O-RING Ø37.82	6	❶
70	41-4415	PISTON BOLT SEAL	1	❶
71	164031	½ - 20 x 1 HEX HD SCREW	1	

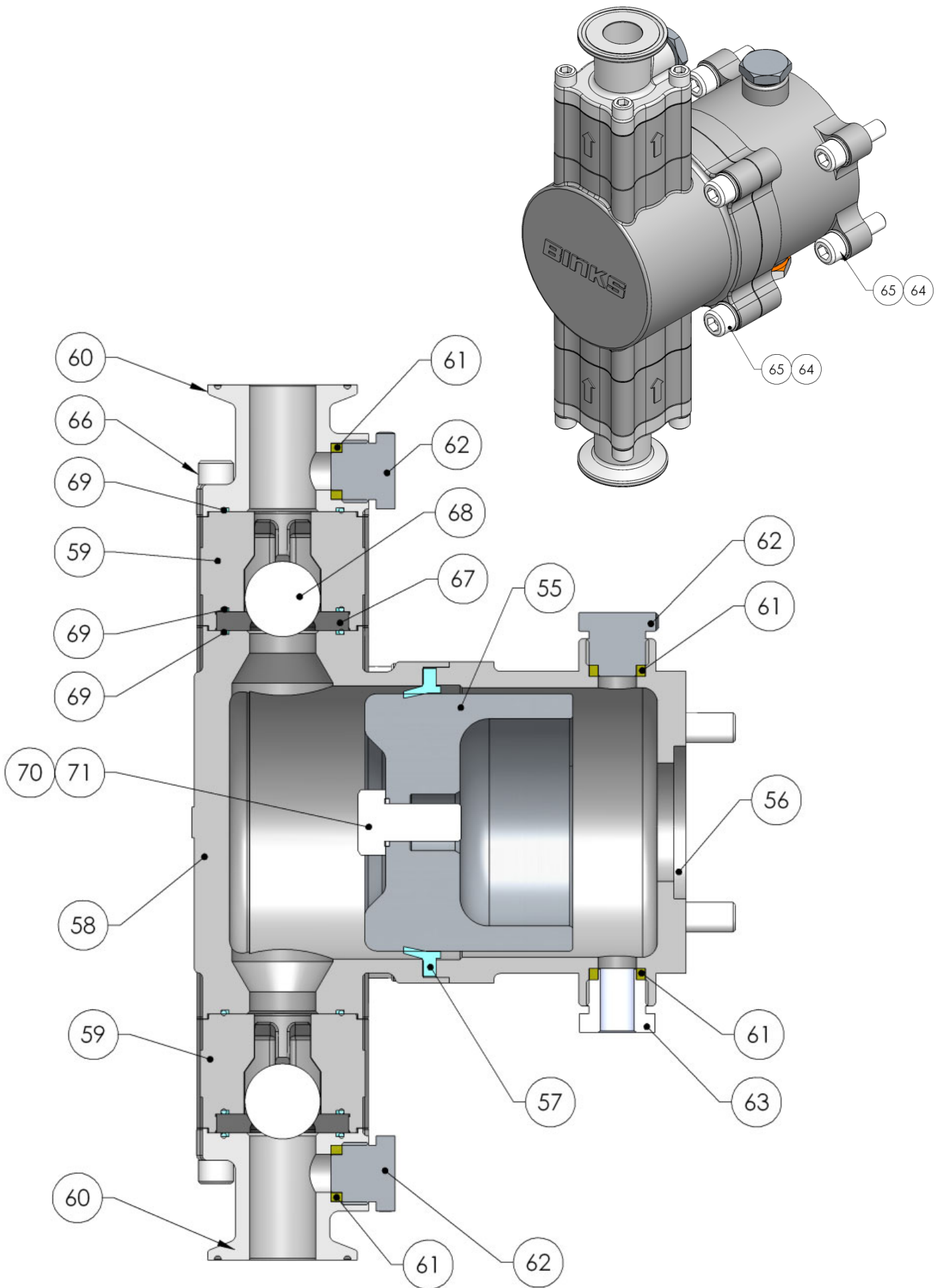

Parts List – Section 4.4

For Reference Only

For pumps with a serial number 53971 or greater poppet valves (31) have been used.

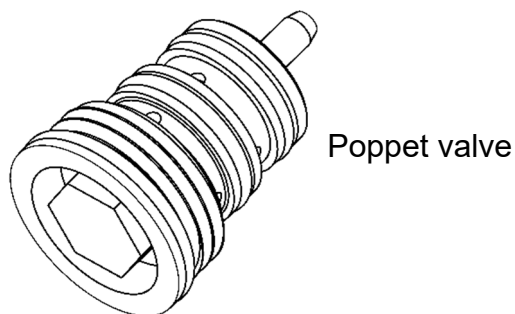

For pumps before serial number 53971 see notes for pilot spool below.

The Pilot Spool (31) is available as a completed and tested assembly; the drawing below is for reference and identification only.

If the pilot spool is removed from the air motor for inspection it is recommended that the 3 off O-ring seals (H) are replaced and lightly greased. Spare Pilot Valves are fitted with the 3 off O-ring 192773.

ITEM	PART No	DESCRIPTION	QTY	REMARKS
H	192773	Ø17 O-RING	3	Ⓢ

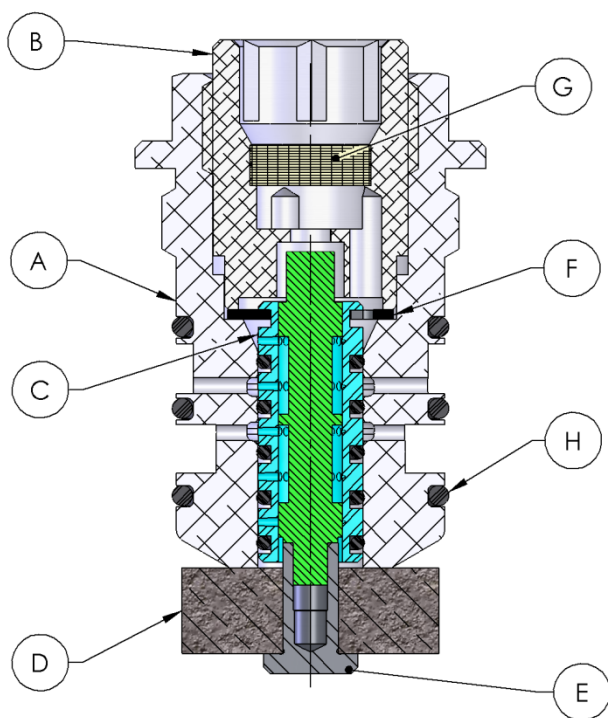

When the valve is removed from the air motor protect the magnet from any form of contamination. (Metallic particles are strongly attracted to the magnet)

Maintenance – Section 5.1 - Assembly Procedure

Pump Assembly – Air Motor

Ensure all parts are clean and degreased.

1. Push bearings (10) into end plates (24) and insert 'O' rings (4) into the large grooves, applying a light coating of grease type #.
2. Apply light coating of grease type # to the seal groove of the piston and insert the 'O' ring portion of the piston seal (8), apply a little more grease to the top of the 'O' ring. Carefully fit the seal strip into the piston groove (fit one half of the seal into the groove and then apply pressure to the o-ring seal already in the groove, and pull the remaining seal into the groove, being careful to avoid unduly stretching the seal strip).
3. Insert grub screw (16) into one of the piston shafts (25) use Loctite studlock 2701 and tighten to 45Nm. Mount this through the piston (26) and screw on the other shaft (25) again using loctite studlock 2701 and tighten to 100Nm. Clean off any residue of loctite.
4. Lightly apply grease type # to the inside of the air motor cylinder (23), insert the piston and shaft sub-assembly into the cylinder at a 45° angle and turn the piston until it is inline with the cylinder.
5. Insert the cylinder end plate sub-assemblies over lightly greased # shafts and into the cylinder. Press parts lightly together, making sure that the Main Valve (3) mounting surfaces are inline.
6. Insert 6 off short tie rods (27) and 2 off long tie rods (28) through the end plates. Fit 16 off washers (12) over the ends of the tie rods. Apply loctite 243 to the LH end of the tie rods and add grease type # to the other end. Fit domed nuts (15) onto the LH loctited end and screw on as far as possible, screw on the remaining domed nuts and tighten in 'cross over' sequence together to 22Nm.
7. Apply grease type # onto the shafts and gently push over the shaft seal (9), lips pointing inwards (Use Tool 502608), push the seal fully home into the end plate. Then fit the bellows retainer (29) over the shafts, smaller hole facing inwards.
8. Screw 502382 assembly spigot onto the piston shaft (25). Using tool 502377 push the bellows (21) over the assembly spigot until the bellows internal spigot locates into the shaft groove. (Using the tool prevents damage to the convolutions)
9. Smear a film of loctite 572 over the nose of the bellows then thread the nut (20) onto the bellows using tool 502377 to push against the nut ensuring the thread starts squarely. Grip the bellows and turn the nut with a 1" A/F spanner until positive resistance is felt. The distance between the nut and the first convolution should be 0 to 1mm.
10. Remove 502382 assembly spigot.
11. Fit mounting brackets (30) to the end plates using 4 off M10 cap head screws (17) and washers (13) tighten to 40Nm. Use loctite 243 on threads.
12. Install 2 off vent plugs (32) into each end plate.

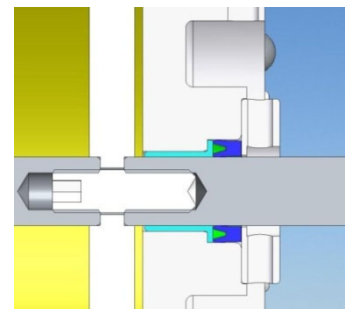

Maintenance – Section 5.1 - Assembly Procedure

Pump Assembly – Air Motor – Control Valves

Pilot Valves (31) - Lightly grease threads and o-rings (grease type #) fit the two pilot valve assemblies into the end plates. Tighten to 8Nm (do not over tighten)

Poppet Valves (31) - Lightly grease threads and o-rings (grease type #) fit the two poppet valves into the end plates. Tighten to 6Nm (do not over tighten)

Main Valve (3):-

1. Ensure all parts are free from contamination especially the magnets (43)
2. Lightly grease valve bore of housing (40) and o-ring of spool assembly (41) Use grease type #
3. Carefully insert the spool assembly into the housing until centrally positioned.
4. Insert bumpers (42) into each end of the spool housing.
5. Insert magnets (43) into end cap (44) then fit o-ring (48) lubricate with grease type # and assemble into housing
6. Fit seals (47) into housing
7. Position diaphragm (46) into cage (45) and fit into housing (locate cages with relevant pin positions, ensure diaphragm is centrally located)
8. Secure with screws (49)
9. Ensure threaded plugs (50) and (51) are in position

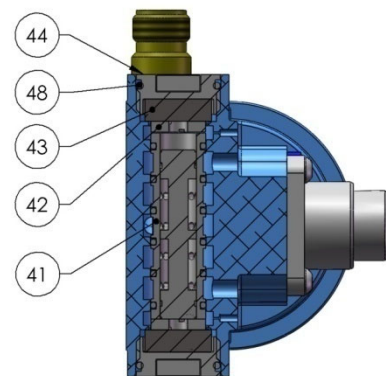

SPOOL DETAIL

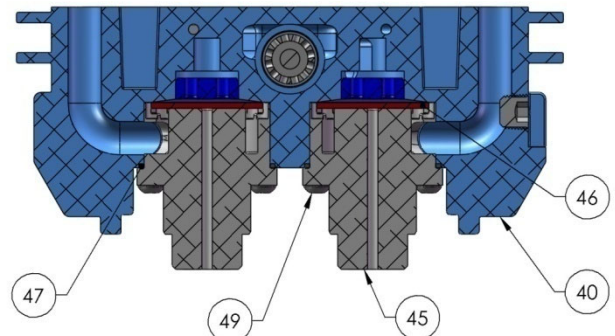

QUICK EXHAUST DETAIL

Assembly Main Valve to Air Motor

1. Fit 2 off o-rings (5) and 4off o-rings (6) into air motor end plates (24)
2. Secure main valve assembly (3) onto the end plates with 4 off cap head screws (11)
3. Fit sealing o-rings (7) onto the exhaust cage (45) lightly grease #
4. Fit exhaust adapter (33) using screws (14) and washers (18)(19) onto the main valve.

Maintenance – Section 5.3 - Assembly Procedure

Pump Assembly – Fluid Section / Air Motor

1. Mount a Dynamic chamber (56) onto each cylinder end plate (24) over each shaft and bellows. Secure loosely with lightly greased 4off M10x35 cap head screws (65) and 4off spring washers (64) so as not to clamp the bellows flange. **Do not tighten cap head screws at this stage as this may lead to bellows damage when assembling the piston to the shaft.**
2. Position a piston (55) onto each piston shaft inside the dynamic chambers. Secure each piston with piston bolt (71) and seal (70), use loctite 272 on the bolt thread.
3. Hold one piston bolt with a 19mm AF socket and tighten the other piston bolt with torque spanner to 40 N-M
4. Fit the piston seals (57), note correct lip orientation.
5. Finally Tighten the cap head screws (65) holding the dynamic chamber to the air motor to 50Nm
6. Fit an output block (58) to the dynamic chambers and secure with cap head screws (65) and spring washer (64), lightly greasing threads to assist future disassembly.

Grease Type #	AGMD-010 - Kluber Isoflex Topas 52
----------------------	---

Maintenance – Section 5.2 - Assembly Procedure

Pump Assembly – Fluid Section

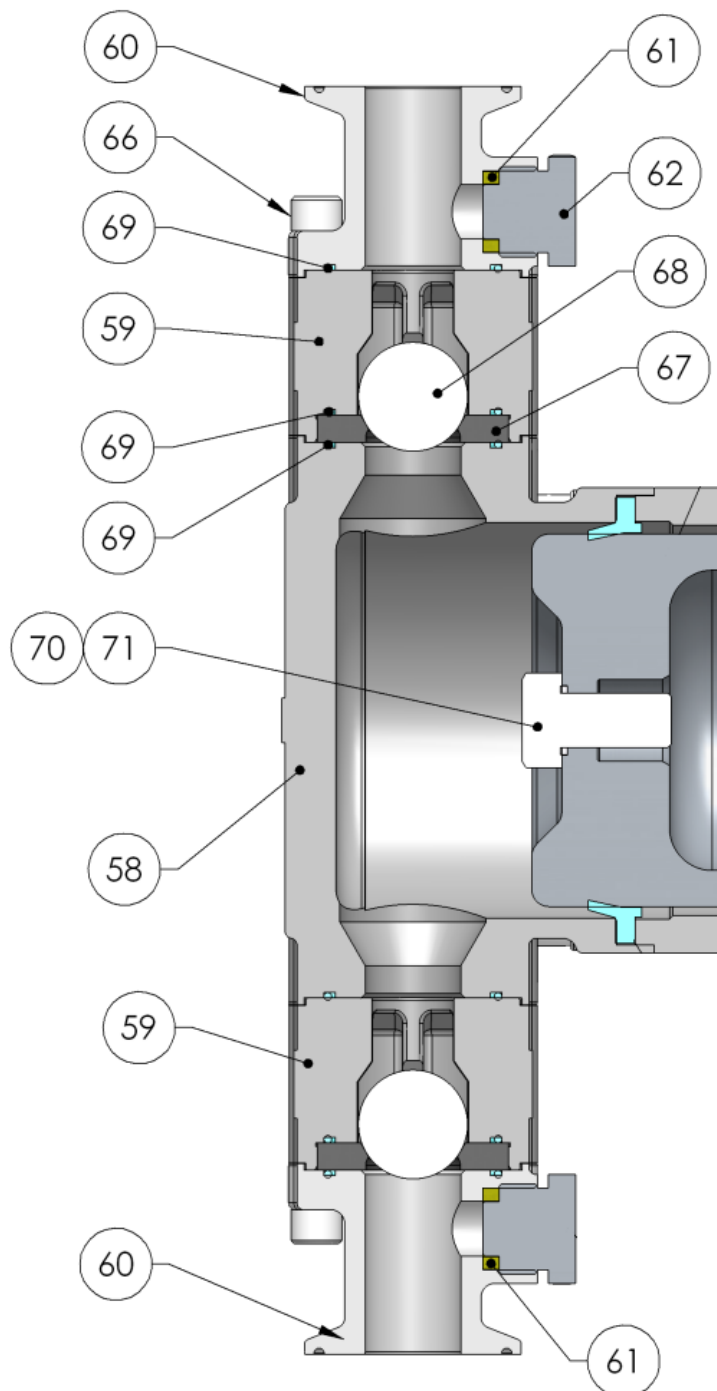

1. Assemble 2 off Ball check sub assemblies as opposite and fit to the output blocks (58)
2. When fitting the ball cage (59) the 'cast' arrow should point upwards
3. When fitting the ball seat (67) the tapered seat should fit against the ball (68)
4. Secure with cap screws (66) lightly greasing threads to assist future disassembly.
5. Install Plug (62 with sealing washer (61) to each flange adapter (60)
6. Mount the inlet (82) and outlet (83) manifolds to the fluid section using clamps (84) and seals (85)
7. Install mufflers (81) into exhaust adapter. Alternatively hose fitting (192802) and 1" plug (192803) can be fitted where piped exhaust is required.

Maintenance – Section 5.4 - Disassembly Procedure

Removal of a Single Fluid Piston

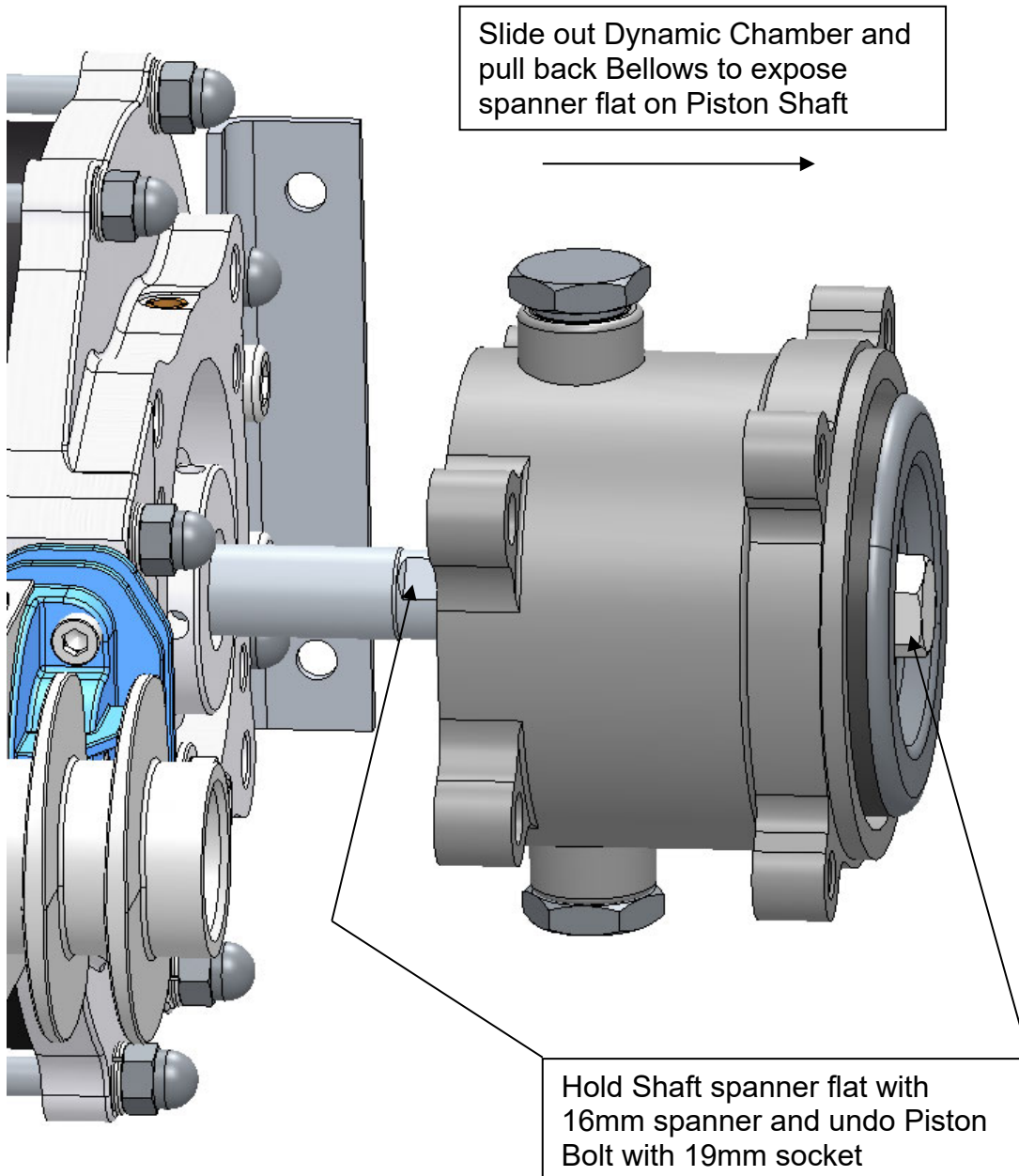

Maintenance – Section 6.1 – General

The working life and thus the expected life prior to replacement of parts within a Paint Pump are greatly affected by three main factors: -

- Abrasiveness of Fluid Pumped
- Pump Duty Cycle
- Fluid Pressure Output requirement

Maintenance Schedule		
Inspection	Operation	
Daily	Check for any general fluid or air leakage.	
Weekly	Inspect Pump for Correct operation Check for any excessive mechanical noise Check for excessive fluid pressure pulsation Check Indication Bottles for signs of paint	
6 Monthly Test	Perform a pump stall test to ensure correct operation. <ul style="list-style-type: none"> • If pump does not stall check fluid piston seals and ball checks, replace as required. • If air is escaping through exhaust check air motor piston seal and quick exhaust diaphragm, replace as required. 	
12 to 36 Months (Typically 10 million Pump Cycles dependant on air quality and abrasiveness of the paint used)	Replace Air Piston seal Replace shaft seals & bearings	③ Air Motor Seal Kit
	Inspect and replace if required:- Pilot/Poppet air Valves Main Air Valve Parts	④ Control Valve Overhaul Kit
	Replace Fluid Piston Seal Replace Bellows	① Fluid Piston Seal Kit

Maintenance – Section 6.2 – Fault Finding

Symptom	Possible Cause	Remedy
Pump will not 'Prime'	<ul style="list-style-type: none"> a. Air getting into the suction hose/manifold b. Worn piston seals c. Ball checks not seating correctly 	<ul style="list-style-type: none"> a. Check seals and hose connections b. Replace piston seals c. Inspect, clean/replace balls/seats
Pump will not run	<ul style="list-style-type: none"> a. No Air or Fluid supply b. Air piston seal worn. c. Pilot/ poppet valve assemblies inoperable. d. Main air valve inoperable e. QE diaphragm defective f. Ball checks not seating 	<ul style="list-style-type: none"> a. Check air and fluid supply ball valves and supply hoses. b. Replace Piston seal c. Switch/interchange pilot valves to isolate faulty pilot valve and clean/replace. d. Check clean/replace Air valve. e. Check for constant exhaust air when pump is not running. Check/replace QE diaphragms f. Inspect, clean and/or replace balls and seats.
Pump runs but has excessive pulsation	<ul style="list-style-type: none"> a. Air getting into fluid line, air supply restricted. b. Obstructed fluid ball checks. c. Worn piston seals. Worn/failed air motor shaft seals. Worn/loose air motor shaft seal components. Worn fluid piston and/or seal. d. Air exhaust restricted. e. Surge eliminator malfunction 	<ul style="list-style-type: none"> a. Check seals and hose connections. Check air supply b. Remove, clean, and inspect seat, ball, and ball cage. Replace if suspect or worn. c. Replace piston seal. Disassemble pump as required to replace all seal components on both sides. d. Check QE diaphragms and exhaust outlet. e. Check surge eliminator for correct operation.
Paint leaking into indication Bottle (86)	Fluid piston seal worn	Replace Piston Seal (57)
Air bleeding from vent plug (32)	Air motor shaft seal leaking	Check Air motor shaft seal (9), replace as necessary

Spare Parts List - Section 7.1

Recommended Replacement Spares Kits for Maple AFP Pump			
Kit No.	Part No.	Description	Remarks
❶	250723	Fluid Piston Seal Kit	Fluid Piston seals Fluid O-rings Manifold seals Knifed Bellows
❸	250618	Air Motor Seal Kit	Air Piston Seal Shaft seals and bearings All O-rings QEV diaphragms
❹	250628	Control Valve Kit	Pilot Valves inc O-rings Main Valve inc O-rings
#	0115-010037*	Poppet Assembly	2 off Per pump
#	0115-010015	Main spool & sleeve valve assembly	1 off Per pump
# - Recommended spare parts for continually running pumps			
* Pumps before serial number 53971 will require; Pilot spool assembly 192765 - control valve kit 25620			
Check Main Parts List for details of individual Kit Contents			

Accessories - Section 7.2

Accessories / Maintenance		
Part No.	Description	Remarks
192206	1 Sanitary Gasket	
192009	1 Sanitary Clamp	
502608	Seal Insertion Tool	For Shaft seal (9)
502770	Bellows Assembly Tool	
502382	Bellows Assembly Spigot	
AGMD-010	Kluber Isoflex Topas NB 52 (Grease type #)	50 ml Tube
192779	Exhaust Tube Adapter (1" NB hose)	For piped exhaust
192820	Exhaust Tube Adapter (1¼" NB hose)	For piped exhaust
192803	1" Manifold Plug	For piped exhaust
192821	1" BSP Heavy Duty Mufflers	Recommended for high pump pressures and cycle rates

WARRANTY POLICY

This product is covered by Carlisle Fluid Technologies' materials and workmanship limited warranty. The use of any parts or accessories, from a source other than Carlisle Fluid Technologies, will void all warranties. Failure to reasonably follow any maintenance guidance provided, may invalidate any warranty.

For specific warranty information please contact Carlisle Fluid Technologies.

Carlisle Fluid Technologies is a global leader in innovative finishing technologies. Carlisle Fluid Technologies reserves the right to modify equipment specifications without prior notice.

DeVilbiss®, Ransburg®, MS®, BGK®, and Binks® are registered trademarks of Carlisle Fluid Technologies, Inc.

© 2018 Carlisle Fluid Technologies, Inc.

All rights reserved.

For technical assistance or to locate an authorised distributor, contact one of our international sales and customer support locations below.

Region	Industrial / Automotive	Automotive Refinishing
Americas	Tel: 1-888-992-4657 Fax: 1-888-246-5732	Tel: 1-800-445-3988 Fax: 1-800-445-6643
Europe, Africa, Middel East, India	Tel: +44 (0)1202 571 111 Fax: +44 (0)1202 573 488	
China	Tel: +8621-3373 0108 Fax: +8621-3373 0308	
Japan	Tel: 081 45 785 6421 Fax: 081 45 785 6517	
Australia	Tel: +61 (0) 2 8525 7555 Fax: +61 (0) 2 8525 7575	

For the latest information about our products, visit www.carlisleleft.com



SOLUTIONS FOR YOUR WORLD