

BINKS[®]

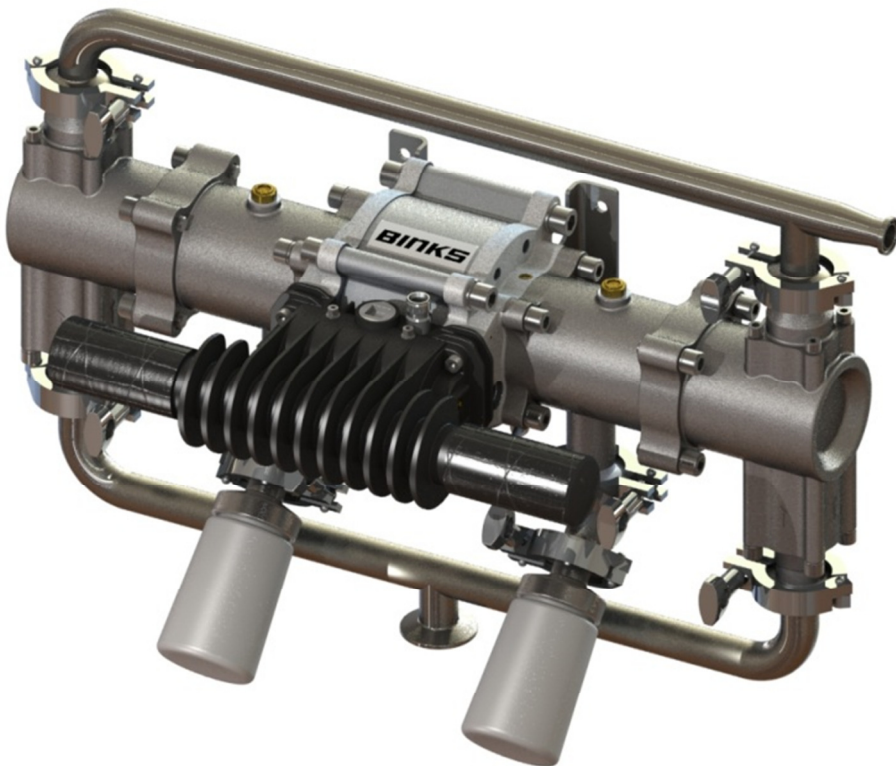

Instruction Manual **Maple 15/3 AFP Pump**

Model 10 41 29



Product Description / Object of Declaration:	Pumps - Maple, DVP, 104009, 104010, 104016, 104027, 104032, 104040, 104041, 104042, 104077, 104020, 104023, 104025, 104028, 104129 106933	EN
This Product is designed for use with:	Solvent and Water based Materials	
Suitable for use in hazardous area:	Zone 1	
Protection Level:	II 2 G X IIB T4	
Notified body details and role:	TRAC Global Ltd (0891) Lodging of Technical file	
This Declaration of conformity / incorporation is issued under the sole responsibility of the manufacturer:	Finishing Brands UK Ltd, Ringwood Road, Bournemouth, BH11 9LH. UK	

EU Declaration of Conformity

The object of the declaration described above is in conformity with the relevant Union harmonisation legislation:

Machinery Directive 2006/42/EC
ATEX Directive 2014/34/EU
by complying with the following statutory documents and harmonized standards:
EN ISO 12100:2010 Safety of Machinery - General Principles for Design
EN 12621:+A1:2010 Machinery for the supply and circulation of coating materials under pressure - Safety requirements
EN1127-1:2011 Explosive atmospheres - Explosion prevention - Basic concepts
EN 13463-1:2009 Non electrical equipment for use in potentially explosive atmospheres - Basic methods and requirements
EN 13463-5:2011 Non electrical equipment for use in potentially explosive atmospheres - Protection by constructional safety

Providing all conditions of safe use / installation stated within the product manuals have been complied with and also installed in accordance with any applicable local codes of practice.

Signed for and on behalf of Finishing Brands UK Ltd:		D Smith	Director of Sales (EMEA)
		20/4/16	Bournemouth, BH11 9LH, UK

Specification	
Pump Ratio	3:1
Max. Air Pressure Inlet	7 Bar
Max. Fluid Pressure	21 Bar
Nominal Flow Volume / Cycle	0.375 Litres 0.10 US Gall
Fluid Output @ 60 cycles/min	22.5 Litres / min 6 US Gall / min
Maximum Recommended Continuous Cycle Rate Maximum Recommended Intermittent Cycle Rate	20 Cycles /min 40 Cycles /min
Fluid Connections Inlet Outlet	1" Sanitary ¾" Sanitary
Compressed Air Inlet	3/8" BSP / NPSM
Air Volume / cycle	0.17 SCFM (4.8 L/m) @ 45PSI (3.1 Bar) 0.33 SCFM (9.3 L/m) @ 90 PSI (6.2 Bar)
Air Flow @ 15 cycles/min 6 bar Air Flow @ 30 cycles/min 6 bar	5 CFM (142 L/min) 10 CFM (283 L/min)
Max. Pump Inlet Pressure	7 Bar (100 PSI)
Air Quality ISO 8573.1 Class 3.3.2 # (See Note)	Dirt 5 microns Water -20°C@7bar (940ppm) Oil 0.1mg/m ³
Total Weight of Pump	25 Kg / 55 lbs
<p># Note: Class 3.4.2 Air Quality (Refrigerant dried - water +3°C@7bar) may be used, however, above 15 cycles/min optional heavy duty mufflers 192821 or piped exhaust system should be used, if used continuously.</p>	

 **WARNING**

Directions for Working Safety

This Product has been constructed according to advanced technological standards and is operationally reliable. Damage may, however, result if it is used incorrectly by untrained persons or used for purposes other than those for which it was constructed.

The locally current regulations for safety and prevention of accidents are valid for the operation of this product under all circumstances.

International, national and company safety regulations are to be observed for the installation and operation of this product, as well as the procedures involved in maintenance, repairs and cleaning.

These instructions are intended to be read, understood and observed in all points by those responsible for this product. These operating and maintenance instructions are intended to ensure trouble free operation. Therefore, it is recommended to read these instructions carefully before start-up. Binks PCE cannot be held responsible for damage or malfunctions resulting from the non-observance of the operating instructions. These instructions including regulations and technical drawings may not be copied, distributed, used for commercial purposes or given to others either in full or in part without the consent of Binks PCE.

We reserve the right to alter drawings and specifications necessary for the technical improvement of this product without notice.

Equipment Misuse Hazard



Equipment misuse can cause the equipment to rupture or malfunction and result in serious injury.



- This equipment is for professional use only.
- Read all instruction manuals, tags, and labels before operating the equipment.
- Use the equipment only for its intended purpose.
- Do not alter or modify this equipment. Use only genuine Binks PCE parts and accessories.
- Check equipment daily. Repair or replace worn or damaged parts immediately.
- Do not exceed the maximum working pressure stated on the equipment or in the Technical Data for your equipment. Do not exceed the maximum working pressure of the lowest rated component in your system.
- Use fluids and solvents which are compatible with the equipment wetted parts. Refer to the Technical Data section of all equipment manuals. Read the fluid and solvent manufacturer's warnings.
- Route hoses away from traffic areas, sharp edges, moving parts, and hot surfaces. Do not expose hoses to temperatures above 82°C (180°F) or below -40°C (-40°F).
- Do not lift pressurized equipment.
- Comply with all applicable local, state, and national fire, electrical, and safety regulations.



Fire, Explosion and Electric Shock Hazard



Improper grounding, poor ventilation, open flames or sparks can cause a hazardous condition and result in a fire, explosion, or electric shock.

When installed and operated in accordance with its instructions, the pump is approved for operation in Zone 1 (Europe) & Division 1 (North America), hazardous locations. (ATEX Cat 2)



- Electrical equipment must be installed, operated, and serviced only by trained, qualified personnel who fully understand the requirements stated in this instruction manual.
- Ground the equipment and all other electrically conductive objects in the spray area. After grounding test with ohmmeter to ensure earth continuity is 1 ohm or less.
- Keep all covers tight while the motor is energized.
- If there is any static sparking or you feel an electric shock while using this equipment, stop spraying/dispersing immediately. Do not use the equipment until you identify and correct the problem.
- Provide fresh air ventilation to avoid the build up of flammable fumes from solvents or the fluid being pumped.
- Keep the pumping area free of debris, including solvent, rags, and gasoline.
- Electrically disconnect all equipment in the pumping area.
- Extinguish all open flames or pilot lights in the spray/dispense area.
- Do not smoke in the spray/dispense area.
- Do not turn on or off any light switch in the spray/dispense area while operating or if fumes are present.





WARNING



READ THE MANUAL

Before operating equipment, read and understand all safety, operation and maintenance information provided in the operation manual.



WEAR SAFETY GLASSES

Failure to wear safety glasses with side shields could result in serious eye injury or blindness.



DE-ENERGIZE, DEPRESSURIZE, DISCONNECT AND LOCK OUT ALL POWER SOURCES DURING MAINTENANCE

Failure to De-energize, disconnect and lock out all power supplies before performing equipment maintenance could cause serious injury or death.



NOISE HAZARD

You may be injured by loud noise. Hearing protection may be required when using this equipment.



OPERATOR TRAINING

All personnel must be trained before operating equipment.



KNOW WHERE AND HOW TO SHUT OFF THE EQUIPMENT IN CASE OF AN EMERGENCY



KEEP EQUIPMENT GUARDS IN PLACE

Do not operate the equipment if the safety devices have been removed.



HIGH PRESSURE CONSIDERATION

High pressure can cause serious injury. Relieve all pressure before servicing. Hose leaks, or ruptured components can inject fluid into your body and cause extremely serious injury.

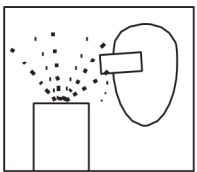

PROJECTILE HAZARD

You may be injured by venting liquids or gases that are released under pressure, or flying debris.



AUTOMATIC EQUIPMENT

Automatic equipment may start suddenly without warning.



PINCH POINT HAZARD

Moving parts can crush and cut. Pinch points are basically any areas where there are moving parts.

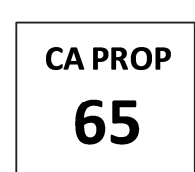

PROP 65 WARNING

WARNING: This product contains chemicals known to the State of California to cause cancer and birth defects or other reproductive harm.



MAGNETIC FIELD PRESENT

You may be subjected to magnetic fields which may interfere with the operation of certain pacemakers.



MAGNET HAZARD

Take care when handling magnets. Avoid getting magnets in close proximity of each other. Injury or damage to magnets may result.

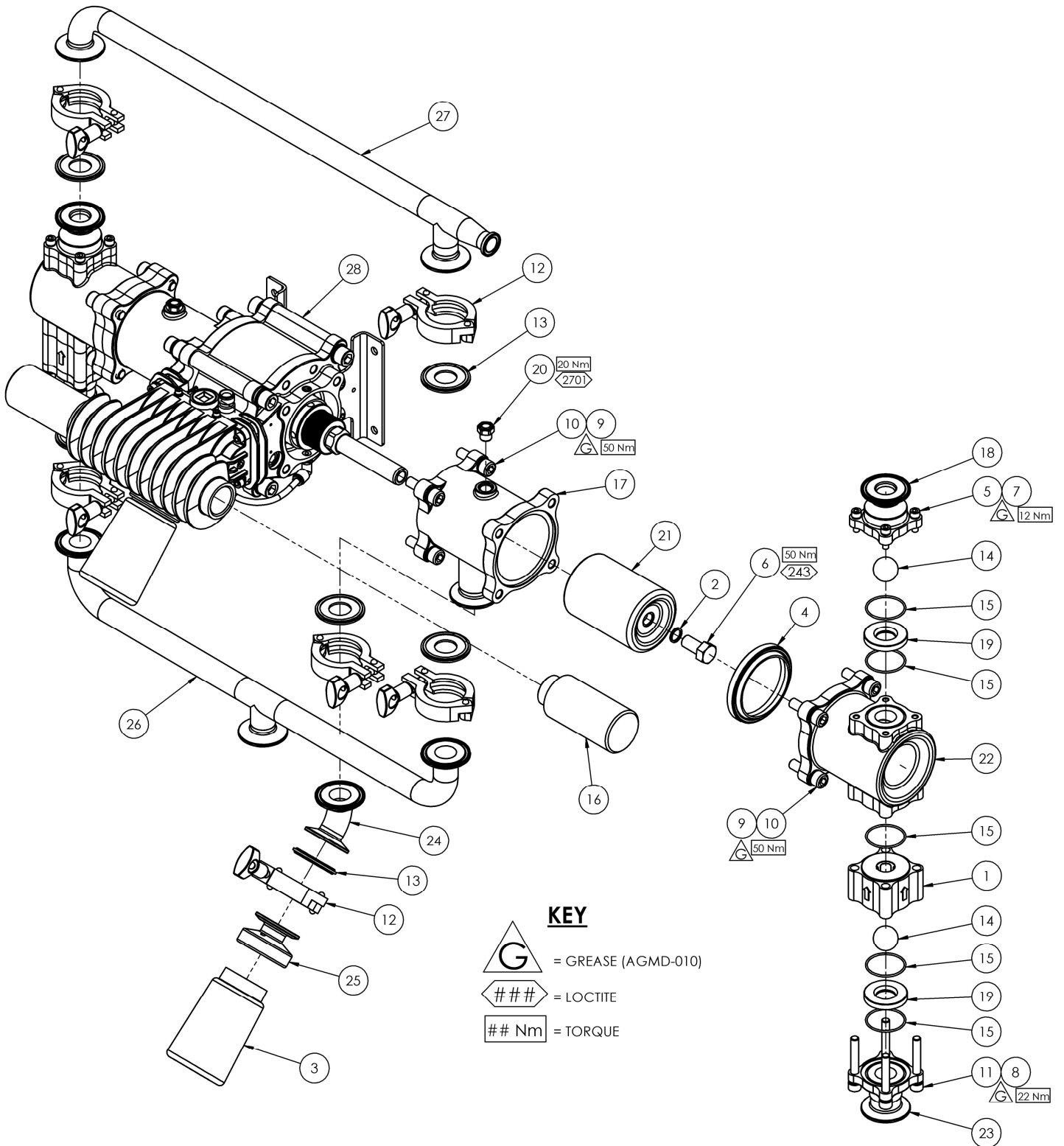

Parts List – 104129 Maple 15 AFP

ITEM	PART No	DESCRIPTION	QTY	REMARKS
1	41-4404	BALL CAGE	2	
2	41-4415	PISTON BOLT SEAL	2	① ②
3	207-12333	BOTTLE	2	
4	162844	PISTON SEAL	2	① ②#
5	163952	M6 x 20 CAP HD SCREW	8	
6	164031	1/2-20 X 1 HEX HD SCREW	2	① ②
7	165087	M6 SPRING WASHER	8	
8	165108	M8 SPRING WASHER	8	
9	165123	M10 SPRING WASHER	16	
10	165947	M10 x 35 CAP HD SCREW	16	
11	165990	M8 x 55 CAP HD SCREW	8	
12	192009	1 & 1 1/2 SANITARY CLAMP	8	
13	192206	1 SANITARY GASKET PTFE	8	① ②
14	192382	1" BALL	4	②
15	192712	O-RING Ø37.82 x 1.78 PTFE	10	① ②
16	192777	1" MUFFLER	2	
17	192825	INLET CYLINDER	2	
18	192827	OUTLET CHECK	2	
19	192833	SEAT	4	②
20	193245	¼" BRASS SILENCER	2	
21	194105	CERAMIC PISTON	2	
22	194178	OUTLET CYLINDER MACHINING	2	
23	194179	INLET ADAPTOR MACHINING	2	
24	194180	1" SANITARY 45° ELBOW	2	
25	194182	BOTTLE ADAPTOR	2	
26	194183	INLET MANIFOLD	1	
27	194184	OUTLET MANIFOLD	1	
28	194196	MAPLE 15 AFP AIR MOTOR	1	

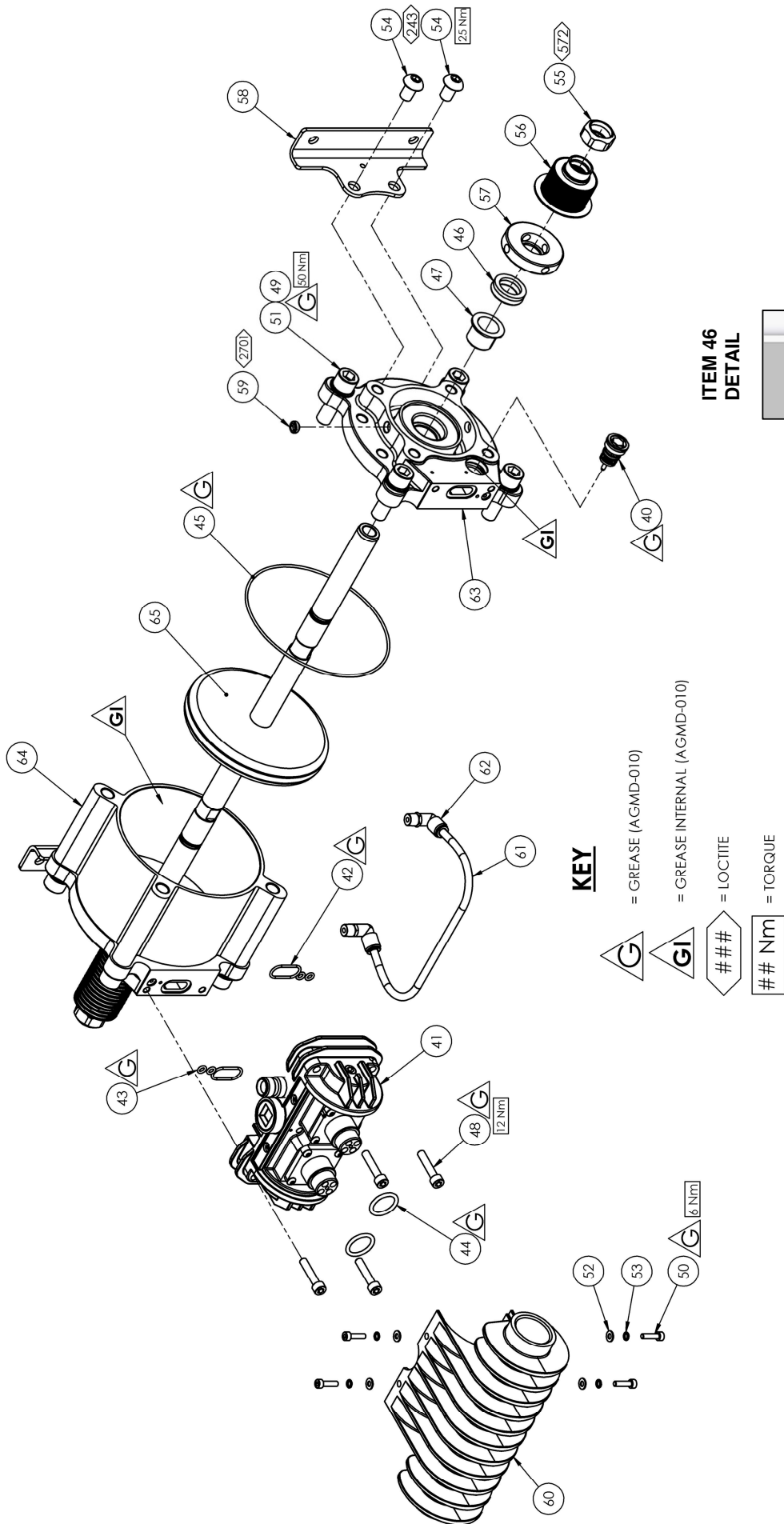

ITEM 46
DETAIL

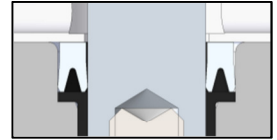

Parts List – 194196 Air Motor

ITEM	PART No	DESCRIPTION	QTY	REMARKS
40	0115-010037	POPPET ASSEMBLY	2	④#
41	0115-010102	AIR VALVE ASSEMBLY	1	
42	161993	Ø20.35 x 1.78 VITON O-RING	2	③
43	161994	Ø4.47 x 1.78 O’RING	4	③
44	161995	Ø19.5 x 3.00 O-RING	2	③
45	161998	Ø125 x 2 O-RING	2	③
46	162703	SHAFT SEAL	2	③
47	162704	SHAFT BEARING	2	③
48	163920	M6 x 30 CAP HD SCREW	4	
49	165044	M12 SPRING WASHER	8	
50	165528	M4 x 16 CAP HD SCREW	4	
51	165960	M12 x 40 CAP HD SCREW	8	
52	165970	M4 PLAIN WASHER	4	
53	165971	Ø4 SPRING WASHER	4	
54	177038	M10 x 12 BUTTON HD CAP SCREW	4	
55	192374	RETAINING NUT	2	
56	192579	KNIFED BELLOWS	2	②#
57	192763	BELLOWS SPACER	2	
58	192764	PUMP BRACKET	2	
59	192799	VENT PLUG	2	
60	192812	EXHAUST ADAPTER	1	
61	192814	BELLOWS LEAK HOSE	1	③
62	192815	1/8R - 6MM PUSH IN ELBOW	2	
63	192830	END PLATE MACHINING	2	
64	192831	AIR CYLINDER	1	
65	194197	AIR MOTOR PISTON ASSY	1	

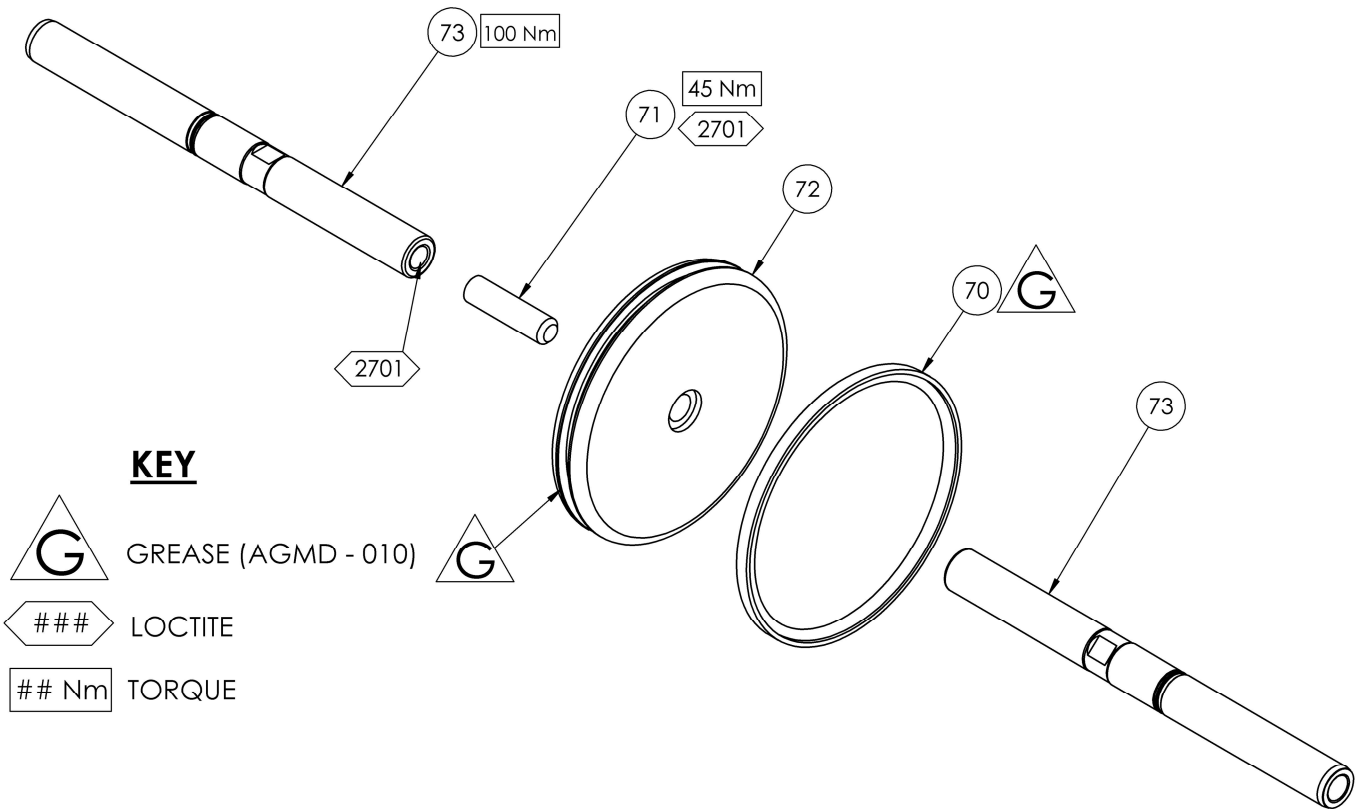

KEY

G GREASE (AGMD - 010)

LOCTITE

Nm TORQUE

Item 65 – 194197 Air Motor Piston Assembly

ITEM	PART No	DESCRIPTION	QTY	REMARKS
70	162707	AIR MOTOR PISTON SEAL	1	Ⓢ
71	165973	M12 x 45 GRUB SCREW	1	
72	192832	AIR MOTOR PISTON	1	
73	194181	PISTON SHAFT	2	

KEY

- = GREASE (AGMD-010)
- = LOCTITE
- = TORQUE
- = GREASE INTERNAL (AGMD-010)
- = MAINTENANCE ORDER (REVERSE FOR ASSY)
- = MAGNET HAZARD

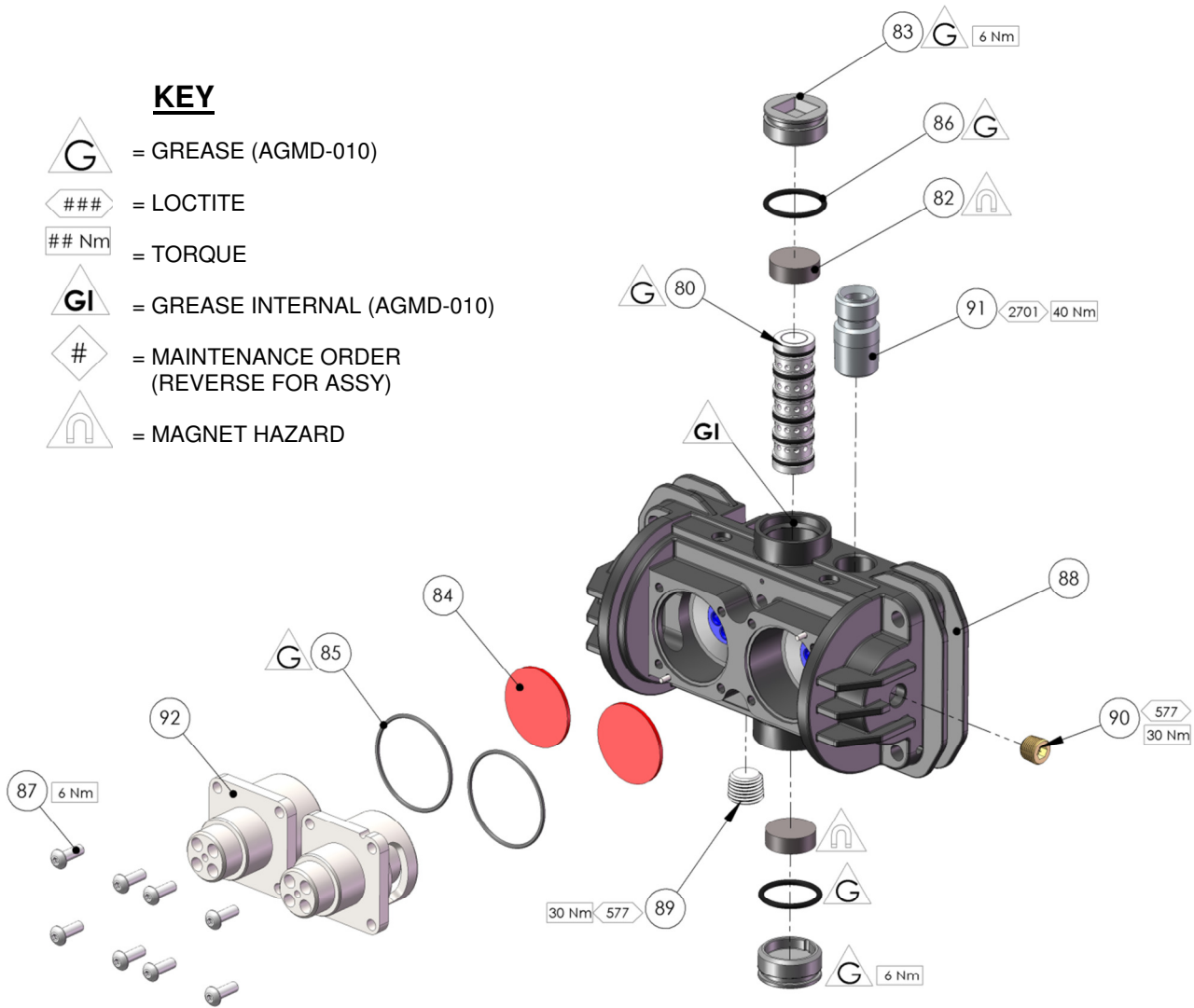

Item 41 - 0115-010102 Valve Assembly

ITEM	PART No	DESCRIPTION	QTY	REMARKS
80	0115-010015	SPOOL AND SLEEVE ASSEMBLY	1	④#
	162789	SPOOL AND SLEEVE O'RING	6	Not Shown
81	0115-010016	BUMPER	2	④
82	0115-010017	MAGNET	2	④
83	0115-010018	VALVE BLOCK END CAP	2	
84	0115-010020	DIAPHRAGM	2	⑤
85	0115-010021	O-RING 1.5 X 36	2	③
86	0115-010049	O-RING 2 x 20	2	④
87	0115-010073	M4 x 12 SHCS	8	
88	0115-010097	VALVE BLOCK	1	
89	0115-010103	1/4 BSPT PIPE PLUG	1	
90	0115-010107	1/8 BSPT PIPE PLUG	1	
91	180584	3/8 UNIVERSAL FITTING	1	
92	192813	QUICK EXHAUST VALVE CAGE	2	

Fault Finding		
Symptom	Possible Cause	Remedy
Pump will not 'Prime'	<ul style="list-style-type: none"> a. Air getting into the suction hose/manifold b. Worn piston seals c. Ball checks not seating correctly 	<ul style="list-style-type: none"> a. Check seals and hose connections b. Replace piston seals c. Inspect, clean/replace balls/seats
Pump will not run	<ul style="list-style-type: none"> a. No Air or Fluid supply b. Air piston seal worn. c. Pilot valve assemblies inoperable. d. Main air valve inoperable e. QE diaphragm defective f. Ball checks not seating 	<ul style="list-style-type: none"> a. Check air and fluid supply ball valves and supply hoses. b. Replace Piston seal c. Switch/interchange pilot valves to isolate faulty pilot valve and clean/replace. d. Check clean/replace Air valve. e. Check for constant exhaust air when pump is not running. Check/replace QE diaphragms f. Inspect, clean and/or replace balls and seats.
Pump runs but has excessive pulsation	<ul style="list-style-type: none"> a. Air getting into fluid line, air supply restricted. b. Obstructed fluid ball checks. c. Worn air motor piston seals. d. Worn/failed air motor shaft seals. e. Worn fluid piston seal. f. Air exhaust restricted. 	<ul style="list-style-type: none"> a. Check seals and hose connections. Check air supply b. Remove, clean, and inspect seat, ball, and ball cage. Replace if suspect or worn. c. Replace air motor piston seal. d. Disassemble pump as required to replace air motor shaft seals. e. Replace fluid piston seal. f. Check QE diaphragms and exhaust outlets.

Spares Kits for Maple 15/3 AFP Pump			
Kit No.	Part No.	Description	Remarks
①	250714	Fluid Section Seal Kit	Check Main Parts List for details of individual Kit Contents
②	250715	Fluid Section Overhaul Kit	
③	250627	Air Motor Seal Kit	
④	250628	Control Valve Kit	
#	0115-010037	Poppet Assembly	2off per Pump
#	0115-010015	Main Spool & Sleeve Valve Assembly	1off per Pump
#	162844	Piston Seal	2off per Pump
#	192579	Knifed Bellows	2off per Pump
# - Recommended Spare Parts for continually running pumps			

Maintenance Schedule	
Inspection	Operation
Daily	Check for any general fluid or air leakage.
Weekly	Inspect Pump for Correct operation Check for any excessive mechanical noise Check for excessive fluid pressure pulsation
6 Monthly Test	Perform a pump stall test to ensure correct operation. <ul style="list-style-type: none"> • If pump does not stall check fluid piston seals and ball checks, replace as required. • If air is escaping through exhaust check air motor piston seal and quick exhaust diaphragm, replace as required.
12 to 36 Months (Typically 10 million Pump Cycles dependant on air quality and abrasiveness of the paint used)	Replace Air Piston seal Replace shaft seals & bearings
	Inspect and replace if required:- Pilot Air Valves Main Air Valve Parts
	Replace Fluid Piston Seal Replace Balls and Seats Replace Bellows

Accessories		
Part No.	Description	Remarks
192206	1" Sanitary Gasket	
192009	1 & 1½" Sanitary Clamp	
502608	Seal Insertion Tool	For Shaft seal (46)
502785	Bellows Assembly Tool	
AGMD-010	Kluber Isoflex Topas NB 52 (Grease type #)	50 ml Tube
192779	Exhaust Tube Adapter (1" NB hose)	For piped exhaust
192820	Exhaust Tube Adapter (1¼" NB hose)	For piped exhaust
192803	1" Manifold Plug	For piped exhaust
192821	1" BSP Heavy Duty Mufflers	Recommended for high pump pressures and cycle rates

Installation

This product should be flushed with a suitable compatible solvent prior to use.

Mount the pump securely and position the pump at a convenient height (below the lid height of the paint container), to allow for maintenance, visual observation, and periodic inspection. The wall mount bracket is included with all pumps.

The Pump Mounting bracket must be connected to a suitable earth ground to ensure that there is no possibility of static build up.

Attach suitable flexible hoses to the inlet and outlet connections. Connect a suitable 3/8 NB air hose and ½" Pressure Filter Regulator to the air motor. (Filter rated at minimum 1000 L/min)

No additional air lubrication is required as piston ring lubricant is applied during assembly or repair. If an air lubricator is used then this must be maintained.

Set the pump speed to a slow cycle rate and start the pump to remove any air from the fluid circuit before increasing pressure. Inspect for any air or fluid leaks.

If an air blow out system is used, never exceed 7 Bar on the inlet of the pump.

Exhaust kits are available for these pumps if the air exhaust is required to be piped away from the pump rather than exhausting locally through the mufflers.

The indicator bottles are provided to show when the fluid seals require to be replaced. Note a new seal may allow a small amount of paint into the cup during the 'bedding in' process.

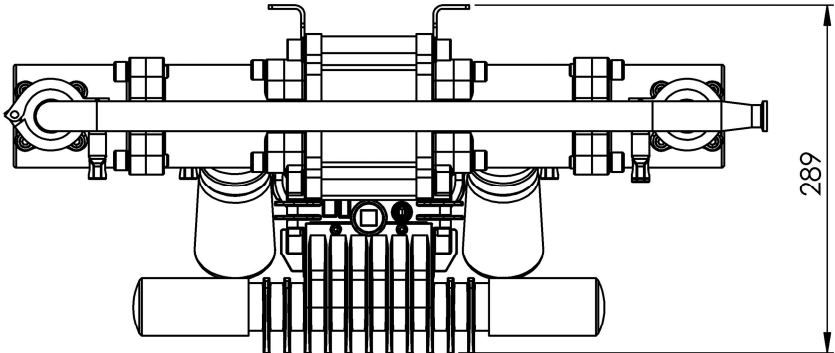
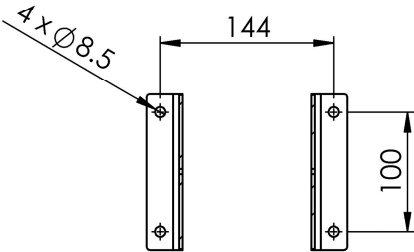
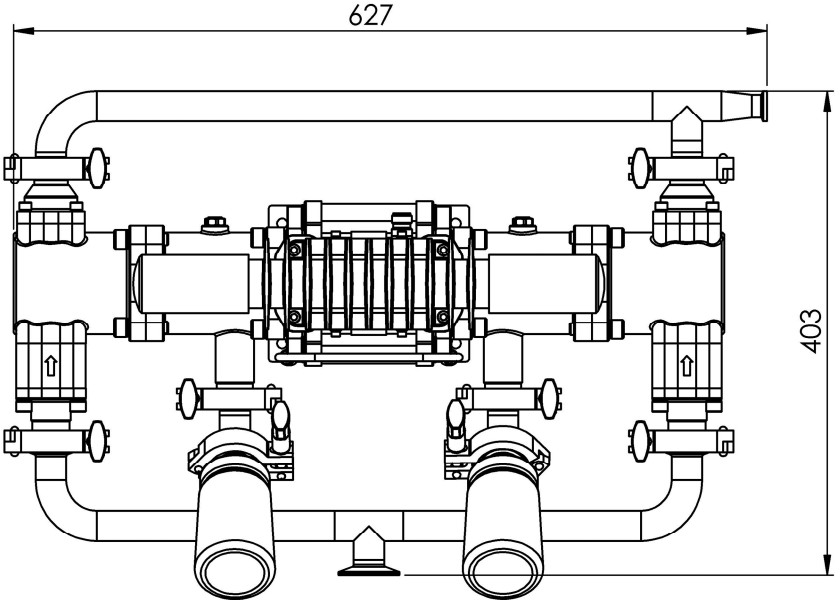
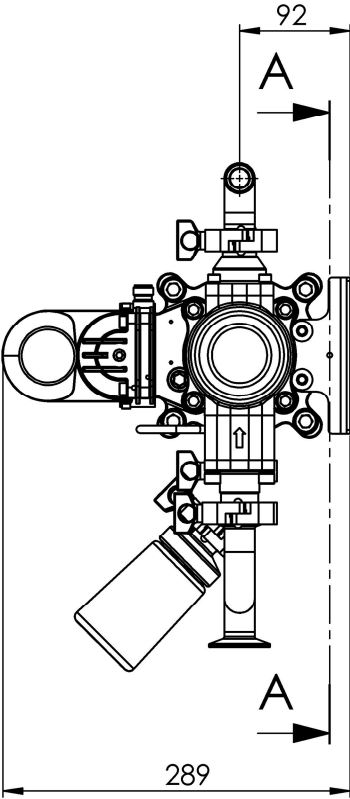

SECTION A-A

WARRANTY POLICY

Binks products are covered by Carlisle Fluid Technologies five year materials and workmanship limited warranty. The use of any parts or accessories, from a source other than Carlisle Fluid Technologies, will void all warranties. For specific warranty information please contact the closest Carlisle Fluid Technologies location listed below.

Carlisle Fluid Technologies reserves the right to modify equipment specifications without prior notice. DeVilbiss®, Ransburg®, MS®, BGK® and Binks® are registered trademarks of Carlisle Fluid Technologies, Inc.

© 2016 Carlisle Fluid Technologies, Inc.
All rights reserved.



Binks is part of Carlisle Fluid Technologies, a global leader in innovative finishing technologies. For technical assistance or to locate an authorized distributor, contact one of our international sales and customer support locations below.

USA/Canada

www.binks.com
info@carisleft.com
Toll Free Tel: 1-800-992-4657
Toll Free Fax: 1-888-246-5732

Mexico

www.carisleft.com.mx
ventas@carisleft.com.mx
Tel: 011 52 55 5321 2300
Fax: 011 52 55 5310 4790

Brazil

www.devilbiss.com.br
vendas@carisleft.com.br
Tel: +55 11 5641 2776
Fax: +55 11 5641 1256

United Kingdom

www.carisleft.eu
info@carisleft.eu
Tel: +44 (0)1202 571 111
Fax: +44 (0)1202 573 488

France

www.carisleft.eu
info@carisleft.eu
Tel: +33(0)475 75 27 00
Fax: +33(0)475 75 27 59

Germany

www.carisleft.eu
info@carisleft.eu
Tel: +49 (0) 6074 403 1
Fax: +49 (0) 6074 403 281

China

www.carisleft.com.cn
mkt@carisleft.com.cn
Tel: +8621-3373 0108
Fax: +8621-3373 0308

Japan

www.ransburg.co.jp
overseas-sales@carisleft.co.jp
Tel: 081 45 785 6421
Fax: 081 45 785 6517

Australia

www.carisleft.com.au
sales@carisleft.com.au
Tel: +61 (0) 2 8525 7555
Fax: +61 (0) 2 8525 7575

