



BINKS "TROPHY" SERIES GRAVITY FEED HVLP, LVMP & CONVENTIONAL MANUAL SPRAY GUNS

(2466-XXXX-XXXX)

CE  II 2 G X

Binks Trophy Series Gravity Spray Gun is the premier spray gun for use in gravity feed spray applications and sets a new standard in durability, ergonomics, and atomization. The lightweight ergonomic design offers unsurpassed comfort and control. The latest advanced atomization technology has been incorporated for achieving consistent, fine finishes when spraying a wide range of industrial coating applications.

Binks Trophy Series Gravity Spray Guns are offered in three different atomization technologies: HVLP, LVMP and Conventional.



SPECIFICATIONS

The Trophy HVLP Series of Spray Guns can be used to operate at high transfer efficiencies in compliance with "California South Coast Air Quality Management District" regulations as a High Volume, Low Pressure spray gun.

Maximum Air Pressure	140 psi / 9.6 bar (P-1)
Gun Body	Anodized Aluminum
Fluid Path	Stainless Steel
Fluid Inlet Size	3/8" - 19 NPS / BSP(f)
Air Inlet Size	1/4" NPS / BSP(m)
Gun Weight	13.8 oz. / 394 grams (less cup)
Wetted Parts	Stainless Steel & PTFE

IMPORTANT! DO NOT DESTROY

It is the customer's responsibility to have all operators and service personnel read and understand this manual. Contact your local Binks representative for additional copies of this manual.

READ ALL INSTRUCTIONS BEFORE OPERATING THIS BINKS PRODUCT.

In this part sheet, the words **WARNING**, **CAUTION** and **NOTE** are used to emphasize important safety information as follows:

! WARNING
Hazards or unsafe practices which could result in severe personal injury, death or substantial property damage.

! CAUTION
Hazards or unsafe practices which could result in minor personal injury, product or property damage.

NOTE
Important installation, operation or maintenance information.

! WARNING

Read the following warnings before using this equipment.



READ THE MANUAL

Before operating finishing equipment, read and understand all safety, operation and maintenance information provided in the operation manual.



WEAR SAFETY GLASSES

Failure to wear safety glasses with side shields could result in serious eye injury or blindness.



DE-ENERGIZE, DEPRESSURIZE, DISCONNECT AND LOCK OUT ALL POWER SOURCES DURING MAINTENANCE

Failure to De-energize, disconnect and lock out all power supplies before performing equipment maintenance could cause serious injury or death.



OPERATOR TRAINING

All personnel must be trained before operating finishing equipment.



EQUIPMENT MISUSE HAZARD

Equipment misuse can cause the equipment to rupture, malfunction, or start unexpectedly and result in serious injury.



KEEP EQUIPMENT GUARDS IN PLACE

Do not operate the equipment if the safety devices have been removed.

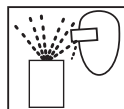

PROJECTILE HAZARD

You may be injured by venting liquids or gases that are released under pressure, or flying debris.



PINCH POINT HAZARD

Moving parts can crush and cut. Pinch points are basically any areas where there are moving parts.



INSPECT THE EQUIPMENT DAILY

Inspect the equipment for worn or broken parts on a daily basis. Do not operate the equipment if you are uncertain about its condition.



NEVER MODIFY THE EQUIPMENT

Do not modify the equipment unless the manufacturer provides written approval.



KNOW WHERE AND HOW TO SHUT OFF THE EQUIPMENT IN CASE OF AN EMERGENCY



PRESSURE RELIEF PROCEDURE

Always follow the pressure relief procedure in the equipment instruction manual.



NOISE HAZARD

You may be injured by loud noise. Hearing protection may be required when using this equipment.



STATIC CHARGE

Fluid may develop a static charge that must be dissipated through proper grounding of the equipment, objects to be sprayed and all other electrically conductive objects in the dispensing area. Improper grounding or sparks can cause a hazardous condition and result in fire, explosion or electric shock and other serious injury.



FIRE AND EXPLOSION HAZARD

Never use 1,1,1-trichloroethane, methylene chloride, other halogenated hydrocarbon solvents or fluids containing such solvents in equipment with aluminum wetted parts. Such use could result in a serious chemical reaction, with the possibility of explosion. Consult your fluid suppliers to ensure that the fluids being used are compatible with aluminum parts.



PROP 65 WARNING

WARNING: This product contains chemicals known to the State of California to cause cancer and birth defects or other reproductive harm.

Product Description/Object of Declaration: Trophy

This Product is designed for use with: Solvent and Water based Materials

Suitable for use in hazardous area: Zone 1 / Zone 2

Protection Level: II 2 G X

Notified body details and role: TRAC Global Ltd (0891)

Lodging of Technical file

**This Declaration of Conformity
/incorporation is issued under the sole
responsibility of the manufacturer:**

Carlisle Fluid Technologies,
320 Phillips Ave.,
Toledo, OH 43612

EU Declaration of Conformity



The object of the declaration described above is in conformity with the relevant Union harmonisation legislation:

Machinery Directive 2006/42/EC

ATEX Directive 2014/34/EU

by complying with the following statutory documents and harmonized standards:

EN ISO 12100:2010 Safety of Machinery - General Principles for Design

BS EN 1953:2013 Atomising and spraying equipment for coating materials - Safety requirements

EN 1127-1:2011 Explosive atmospheres - Explosion prevention - Basic concepts

EN 13463-1:2009 Non electrical equipment for use in potentially explosive atmospheres - Basic methods and requirements

Providing all conditions of safe use / installation stated within the product manuals have been complied with and also installed in accordance with any applicable local codes of practice.

Signed for and on behalf of
Carlisle Fluid Technologies:

DJ Hasselschwert
11-Jul-16

(Vice President: Global
Product Development)
Toledo, OH 43612

BINKS "TROPHY" SERIES GRAVITY SPRAY GUN

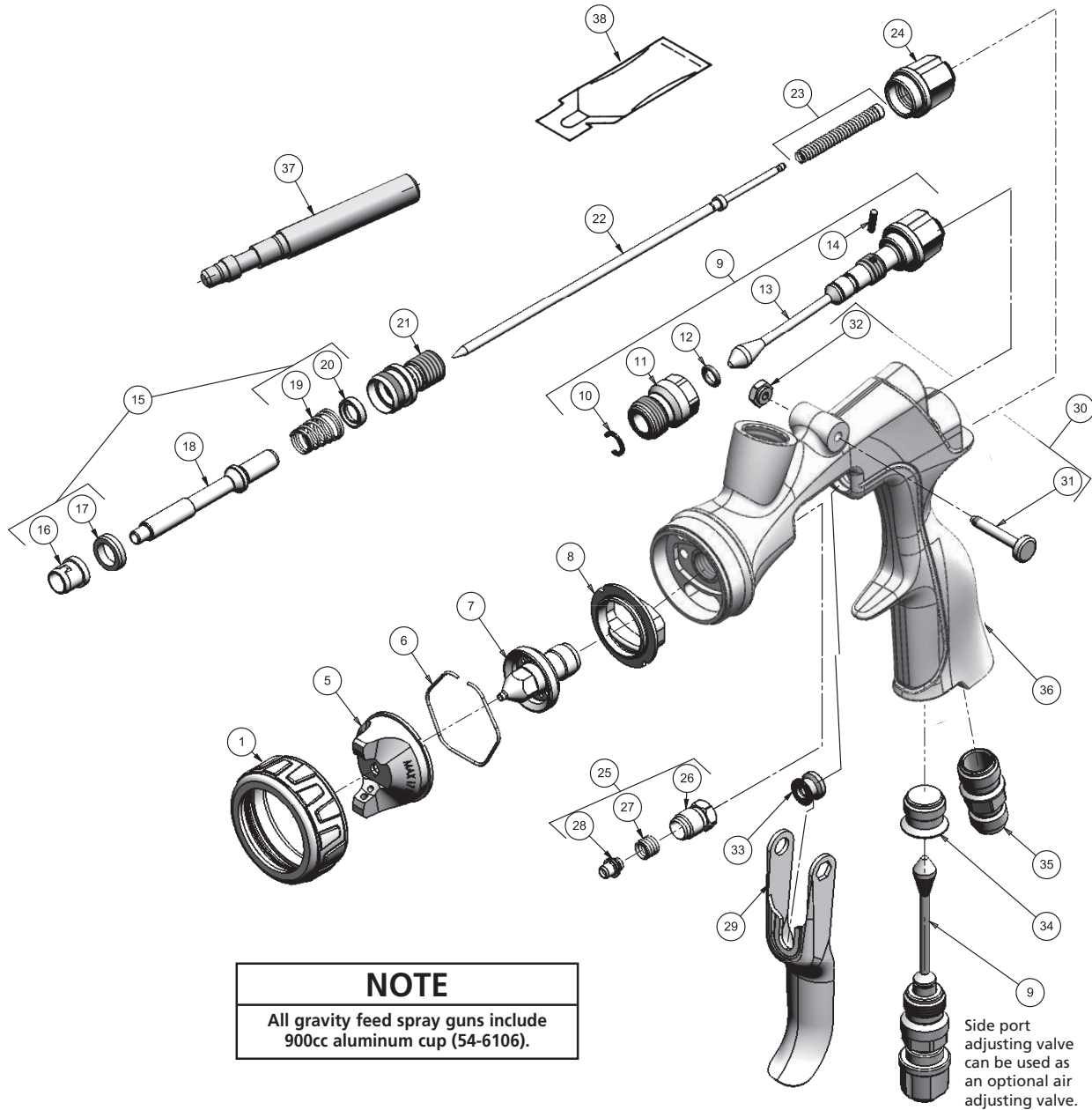

NUMBERING SYSTEM FOR FULL SIZE BINKS "TROPHY" SERIES GRAVITY SPRAY GUNS

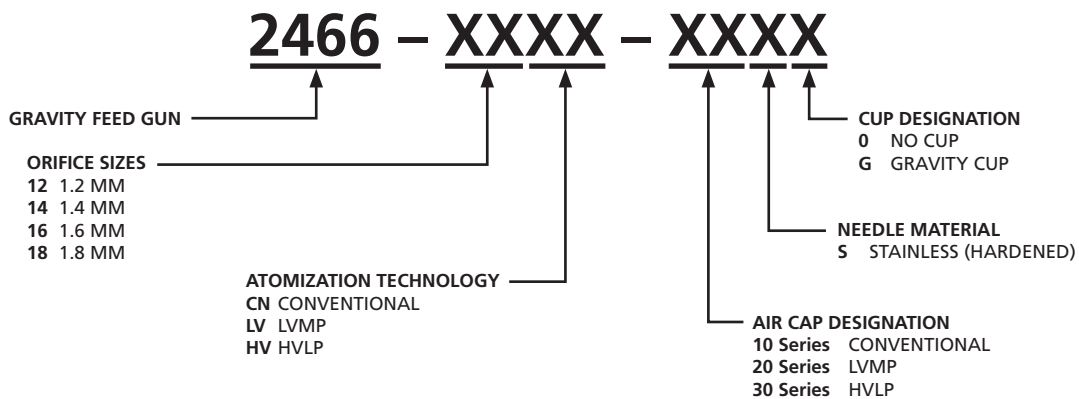

See charts on page 6 for complete gun assemblies.

CHART 1: BINKS "TROPHY" SERIES GRAVITY SPRAY GUN PARTS LIST

ITEM NO.	PART NUMBER	DESCRIPTION	QTY.	ITEM NO.	PART NUMBER	DESCRIPTION	QTY.		
1	54-6120	AIR CAP RETAINING RING ASSEMBLY	1	24	54-6111	KNOB – NEEDLE ADJUSTING	1		
5	SEE CHARTS ON PAGE 7	AIR CAP	1	25	54-6130-K	NEEDLE PACKING KIT (STANDARD)	1		
6	JGA-156-K10	SPRING-CLIP (KIT OF 10)	1	26	-----	■	NUT – PACKING	1	
7	SEE CHARTS BELOW	FLUID NOZZLE	1	27	-----	■	SPRING FOR PACKING	1	
8	54-6102-K3	BAFFLE/SEPARATOR (KIT OF 3)	1	28	-----	□ ■ ▼	NEEDLE PACKING (STANDARD)	1	
9	54-6122	SIDE PORT VALVE ASSEMBLY	1	29	54-4360	TRIGGER	1		
10	-----	+ △	RETAINING CLIP	1	30	54-6132-K	TRIGGER SCREW NUT KIT	1	
11	-----	+	BODY BUSHING	1	31	-----	○	TRIGGER SCREW	1
12	-----	+ △	O-RING	1	32	-----	○	TRIGGER NUT	1
13	-----	+	SIDE PORT STEM	1	33	54-3513	SPINDLE CAP	1	
14	-----	+ △	PIN	1	34	SN-11	PLUG	1	
15	54-6131-K	□	AIR VALVE SERVICE KIT	1	35	54-6112	FITTING – AIR INLET	1	
16	-----	•	FRONT SEAL – AIR VALVE	1	36	-----	GUN BODY WITH FLUID INLET	1	
17	-----	•	FRONT AIR VALVE SEAL	1	37	-----	TOOL – SEAL INSERTION	1	
18	54-6109	□	AIR VALVE SPINDLE	1	38	-----	GUNNER'S MATE (3 CC BAG)	1	
19	-----	•	AIR VALVE SPRING	1					
20	-----	•	REAR SEAL – AIR VALVE	1					
21	SN-66	HOUSING	1						
22	47-6825	NEEDLE – STAINLESS STEEL (STD.)	1						
23	-----	□	SPRING/PAD ASSEMBLY	1					
	54-6133-K3	SPRING/PAD ASSEMBLY (KIT OF 3)	1						

+	PARTS INCLUDED IN 54-6122	○	PARTS INCLUDED IN 54-6132-K
■	PARTS INCLUDED IN 54-6130-K	△	GTI-428-K5 SIDE PORT REPAIR KIT
▼	ALSO AVAILABLE IN KIT OF 3 SN-2-K3	□	PARTS INCLUDED IN 54-6135
•	PARTS INCLUDED IN 54-6131-K		

**CHART 2:
STAINLESS STEEL (HARDENED)
FLUID NOZZLES – STD.**

STAINLESS FLUID NOZZLE ORIFICE SIZE		FLUID NOZZLE PART NUMBER
.039"	1.0 mm	45-11050-10
.047"	1.2 mm	45-11050-12
.055"	1.4 mm	45-11050-14
.063"	1.6 mm	45-11050-16
.071"	1.8 mm	45-11050-18

**CHART 3:
TEST AIR CAP KITS –
OPTIONAL**

CONVENTIONAL	
54-6141-K	12-C KIT
LVMP	
54-6147-K	23-L KIT
HVLP	
54-6152-K	32-H KIT – HVLP

BINKS "TROPHY" SERIES GRAVITY SPRAY GUN NEEDLE AND NOZZLE SELECTION GUIDE

CHART 4: CONVENTIONAL GUN SET-UPS

TYPE OF FLUID TO BE SPRAYED	COMPLETE GUN ASSEMBLY PART NUMBER	FLUID NOZZLE AND AIR CAP
THIN 5-25 CENTIPOISE 15-19 sec. Zahn 2 cup wash primers, dyes, stains, solvents, water, inks, sealers, laquers, lubricants, zinc chromates, acrylics	2466-14CN-12SG	1.4 mm (.055") X 12C
	2466-16CN-12SG	1.6 mm (.063") X 12C
MEDIUM 25-70 CENTIPOISE 20-30 sec. Zahn 2 cup synthetic enamels, varnishes, shellacs, fillers, primers, epoxies, urethanes, lubricants, wax emulsions, enamels	2466-16CN-12SG	1.6 mm (.063") X 12C
	2466-18CN-12SG	1.8 mm (.070") X 12C

CHART 5: LVMP GUN SET-UPS

TYPE OF FLUID TO BE SPRAYED	COMPLETE GUN ASSEMBLY PART NUMBER	FLUID NOZZLE AND AIR CAP
THIN 5-25 CENTIPOISE 15-19 sec. Zahn 2 cup wash primers, dyes, stains, solvents, water, inks, sealers, laquers, lubricants, zinc chromates, acrylics	2466-12LV-23SG	1.2 mm (.067") X 23L
	2466-14LV-23SG	1.4 mm (.055") X 23L
MEDIUM 25-70 CENTIPOISE 20-30 sec. Zahn 2 cup synthetic enamels, varnishes, shellacs, fillers, primers, epoxies, urethanes, lubricants, wax emulsions, enamels	2466-14LV-23SG	1.4 mm (.055") X 23L
	2466-18LV-23SG	1.8 mm (.070") X 23L

CHART 6: HVLP GUN SET-UPS

TYPE OF FLUID TO BE SPRAYED	COMPLETE GUN ASSEMBLY PART NUMBER	FLUID NOZZLE AND AIR CAP
THIN 5-25 CENTIPOISE 15-19 sec. Zahn 2 cup wash primers, dyes, stains, solvents, water, inks, sealers, laquers, lubricants, zinc chromates, acrylics	2466-12HV-32SG	1.2 mm (.047") X 32H
	2466-14HV-32SG	1.4 mm (.055") X 32H
MEDIUM 25-70 CENTIPOISE 20-30 sec. Zahn 2 cup synthetic enamels, varnishes, shellacs, fillers, primers, epoxies, urethanes, lubricants, wax emulsions, enamels	2466-14HV-32SG	1.4 mm (.055") X 32H
	2466-18HV-32SG	1.8 mm (.070") X 32H

BINKS "TROPHY" SERIES GRAVITY SPRAY GUN AIR CAP AND FLUID NOZZLE SELECTION CHARTS

CHART 7: CONVENTIONAL AIR CAP AND FLUID NOZZLE SELECTION CHART							
Air Cap	Air Cap Part No.	Spray Pattern Range	CFM @ 30 PSI	CFM @ 50 PSI	CFM @ 70 PSI	Fluid Nozzle	Typical Coatings
12-C	46-6501	4 – 12"	8.3	12.1	14.2	45-11050 series, 1.2 mm – 1.8 mm	Lacquers, Enamels, Top Coats, Low Viscosity Adhesives

CHART 8: LVMP – LOW VOLUME MEDIUM PRESSURE AIR CAP AND FLUID NOZZLE SELECTION CHART					
Air Cap	Air Cap Part No.	Spray Pattern Range	CFM @30 PSI Gun Inlet (Dynamic)	Fluid Nozzle	Typical Coatings
23-L	46-6511	4 – 12"	10.6	45-11050 series, 1.2 mm – 1.8 mm	Lacquers, Enamels, Top Coats, Low Viscosity Adhesives
24-L	46-6512	2 – 6"	14.3	45-11050 series, 1.0 mm – 1.8 mm	Small Pattern Applications of Stains, Lacquers, Enamels, Acrylics

CHART 9: HVLP – HIGH VOLUME LOW PRESSURE AIR CAP AND FLUID NOZZLE SELECTION CHART						
Air Cap	Air Cap Part No.	Spray Pattern Range	SCFM @ 10 PSI Cap Pressure (Dynamic)	Gun Inlet PSI @ 10 PSI at Air Cap (Dynamic)	Fluid Nozzle	Typical Coatings
32-H	46-6518	8 – 14"	15.5	26	45-11050 series, 1.2 mm – 1.8 mm	Lacquers, Enamels, Multi-Colors, Multi-Spec, Nonstick Coatings, Cut-Latex

CHART 10: ROUND SPRAY AIR CAP AND FLUID NOZZLE SELECTION CHART (OPTIONAL)							
Air Cap	Air Cap Part No.	Spray Pattern Range	CFM @ 30 PSI	CFM @ 50 PSI	CFM @ 70 PSI	Fluid Nozzle	Typical Coatings
16	46-6505	2 – 4"	5.6	7.8	10.5	45-11050 series, 1.2 mm – 1.8 mm	Lacquers, Enamels

TYPES OF INSTALLATION

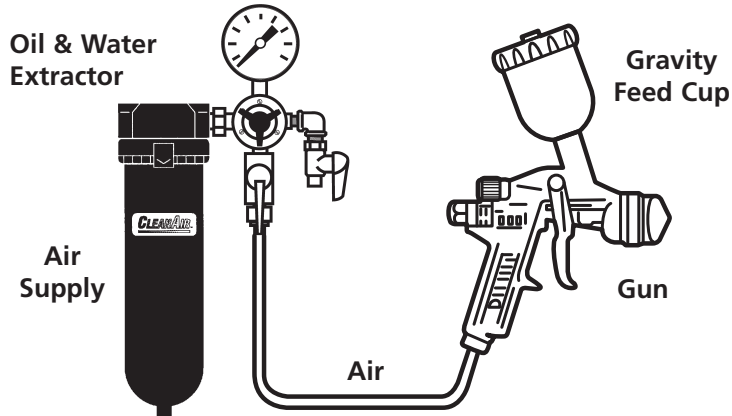

Air pressure for atomization is regulated at the extractor. The flow of the fluid is adjusted by the fluid valve control knob on gun, viscosity of paint and air pressure.

GRAVITY FEED HOOKUP

On gravity-feed spray guns the cup is located above the gun. The force of gravity pushes the fluid into the gun.

Advantages: this method offers quick color changes and convenience on small jobs or touch-up applications. Gravity spray guns are able to use all of the coating—reducing waste.

AIR PRESSURE

Atomizing pressure must be set properly to allow for the drop in air pressure between the regulator and the spray gun.

WITH 60 PSI APPLIED AT AIR SUPPLY

Cross section view showing comparison of inside hose diameters (actual size). 60 lbs. regulated pressure



5/16"

RECOMMENDED
48 PSI at gun inlet

25 feet of 5/16" I.D. hose causes a drop of 12 PSI between the air supply and the gun. For this reason Binks recommends the use of 5/16" hose.



1/4"

NOT RECOMMENDED
Only 34 PSI at gun inlet

25 feet of 1/4" I.D. hose causes a drop of 26 PSI between the air supply and the gun.

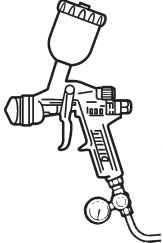

An oil and water extractor is important.

Achieving a fine spray finish without the use of a good oil and water extractor is virtually impossible.

A regulator/extractor serves a double purpose. It eliminates blistering and spotting by keeping air free of oil and water, and it gives precise air pressure control at the gun.

Use DeVilbiss oil and water extractors and regulators. See your local distributor for models.

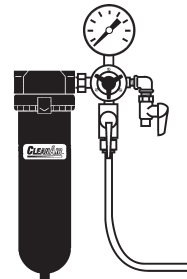

INSTALLATION INSTRUCTIONS

For maximum transfer efficiency, do not use more pressure than is necessary to atomize the material being applied.

NOTE

When using HVLP do not exceed inlet pressures listed on page 7.

1. Connect the gun to a clean, moisture and oil free air supply using a conductive hose of at least 5/16 in I.D.

NOTE

Depending on hose length, larger I.D. hose may be required. Install an air gauge at the gun handle. See page 7 for operating pressures. Do not use more pressure than is necessary to atomize the material being applied. Excess pressure will create additional overspray and reduce transfer efficiency.

NOTE

If quick connect couplings are required, use only high flow quick connects approved for HVLP use. Other types will not flow enough air for correct gun operation.

NOTE

If an air adjusting valve is used at the gun inlet, use HAV-501 adjusting valve.

NOTE

Before using the spray gun, flush it with solvent to ensure that the fluid passages are clean.

OPERATION

GRAVITY MODELS

1. Mix coating material to manufacturer's instructions and strain material.
2. Fill the cup to no more than 3/4 inch from the top of the cup. **DO NOT OVERFILL.**
3. Attach to cup lid.
4. Turn fluid adjusting knob (24) clockwise to prevent fluid needle movement.
5. Turn sideport control (9) counter clockwise to fully open.
6. Adjust inlet air pressure if required.
7. Turn fluid adjusting knob counter clockwise until first thread shows.
8. Test spray. If the finish is too dry, reduce airflow by reducing air inlet pressure.

9. If finish is too wet, reduce fluid flow by turning fluid adjusting knob (24) clockwise. If atomization is too coarse, increase inlet air pressure. If too fine, reduce inlet pressure.
10. The pattern size can be reduced by turning sideport control (9) clockwise.
11. Hold gun perpendicular to surface being sprayed. Arcing or tilting may result in uneven coating.
12. The recommended spray distance is 8 inches.
13. Spray edges first. Overlap each stroke a minimum of 75%. Move gun at a constant speed.
14. Always turn off air supply and relieve pressure when gun is not in use.

PREVENTIVE MAINTENANCE AND CLEANING

To clean air cap and fluid nozzle, brush exterior with a stiff bristle brush. If necessary to clean cap holes, use a broom straw or toothpick if possible. If a wire or hard instrument is used, extreme care must be used to prevent scratching or burring of the holes which will cause a distorted spray pattern.

To clean fluid passages, remove excess material from gun, then flush with gun wash solution. Wipe the gun exterior with a dampened cloth. Never completely immerse in any solvent or cleaning solutions as this is detrimental to the lubricants and life of the spray gun.

NOTE

When replacing the fluid nozzle (7) or fluid needle (22), replace both at the same time. Using worn parts can cause fluid leakage. See page 4. Also, replace the needle packing at this time. Torque the fluid nozzle to 230–240 inch-lbs. Do not over tighten.

CAUTION

To prevent damage to fluid nozzle (7) or fluid needle (22), be sure to either 1) pull the trigger and hold while tightening or loosening the fluid nozzle, or 2) remove fluid adjusting knob (24) to relieve spring pressure against needle collar.

GRAVITY CUP. Empty excess material and clean the cup. Make sure the vent hole in the lid is clear.

REMOVAL AND INSTALLATION PROCEDURES

NEEDLE AND VALVE DISASSEMBLY AND ASSEMBLY

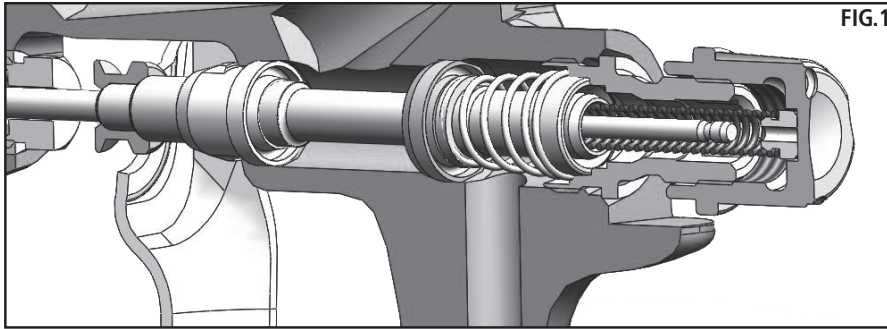

DISASSEMBLY

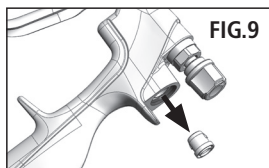
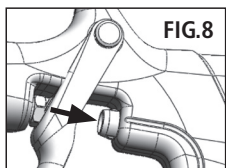
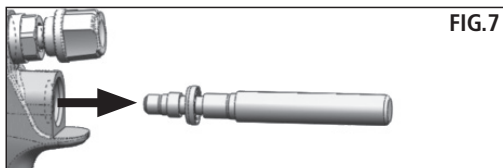
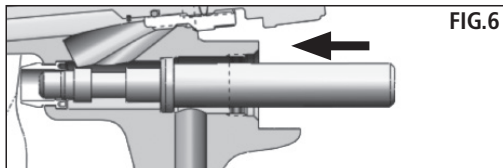
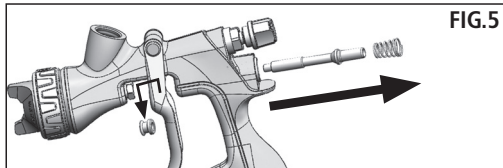
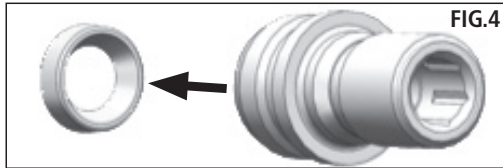
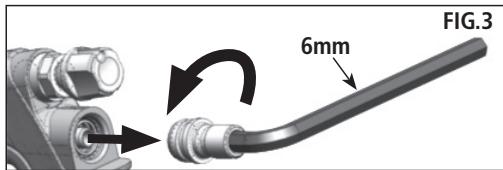
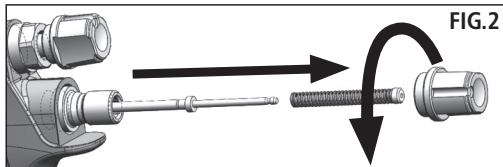

ASSEMBLY

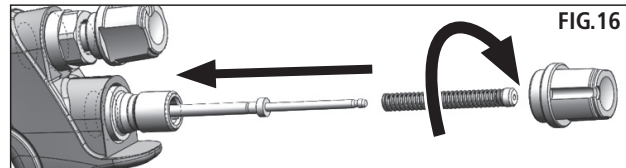
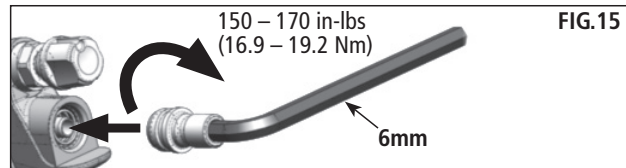
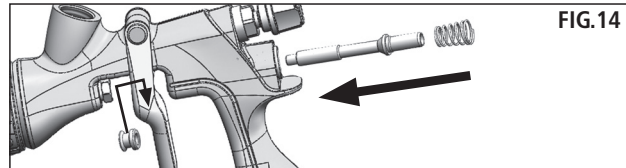
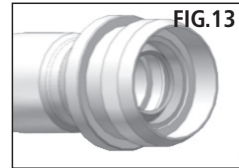
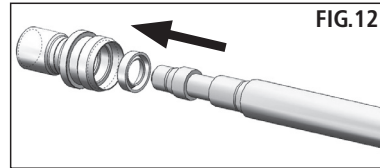
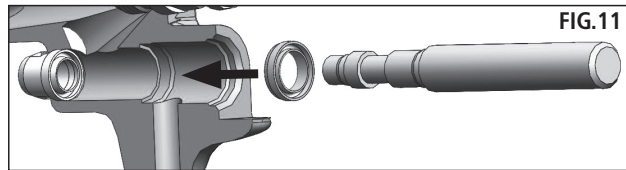
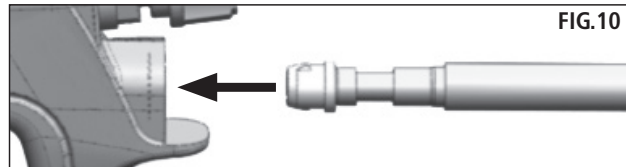

MAINTENANCE – FLUID NOZZLE AND BAFFLE REMOVAL AND INSTALLATION

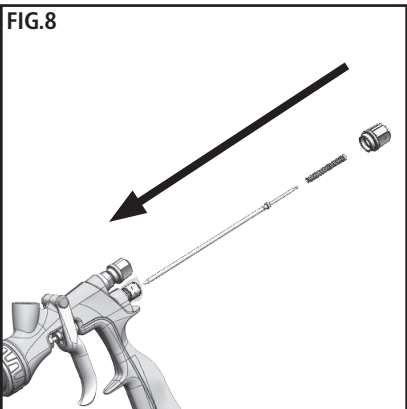
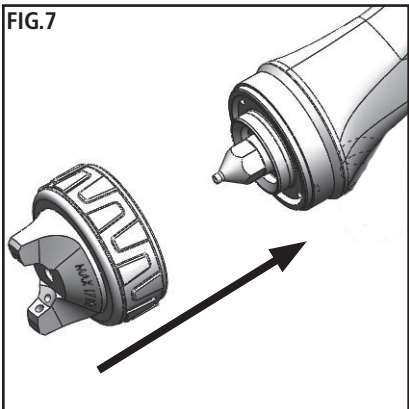
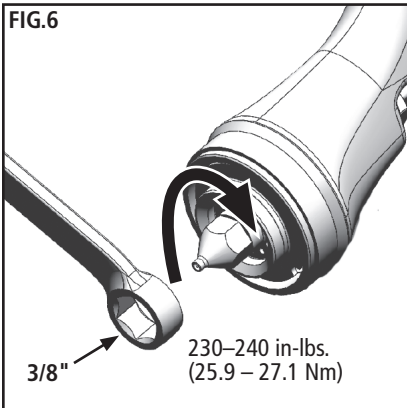
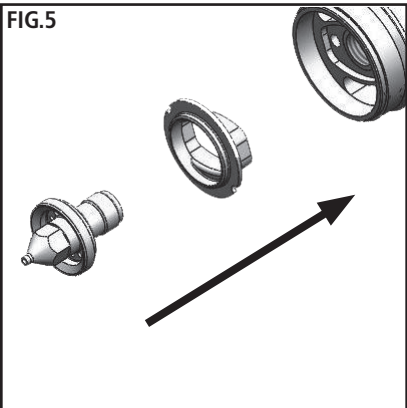
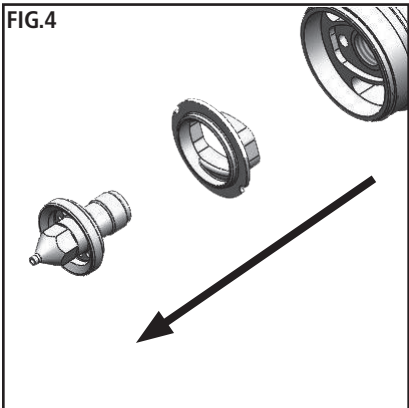
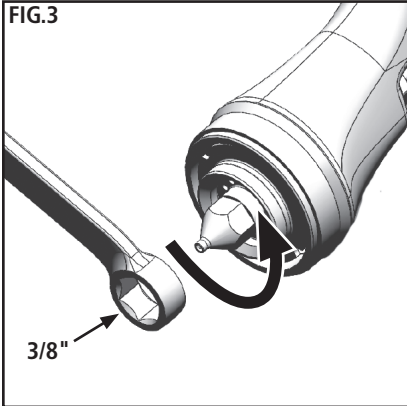
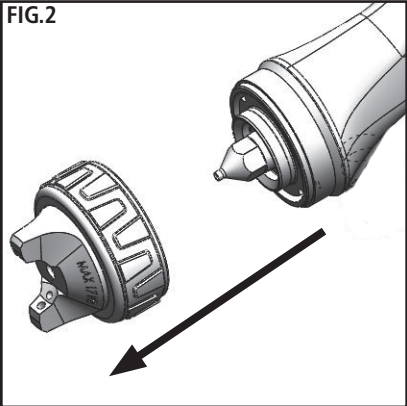
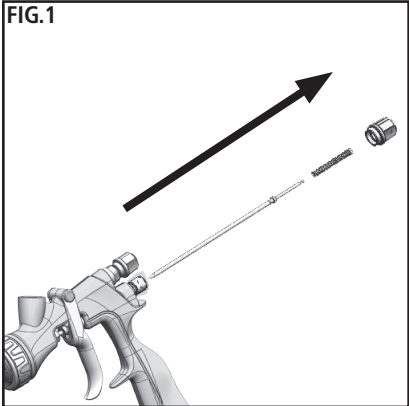

AIR CAP INDEX PIN (54-6184) INSTALLATION (OPTIONAL – 90° INCREMENTS INDEXING FEATURE)

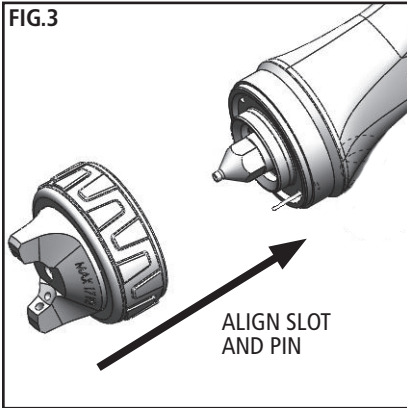
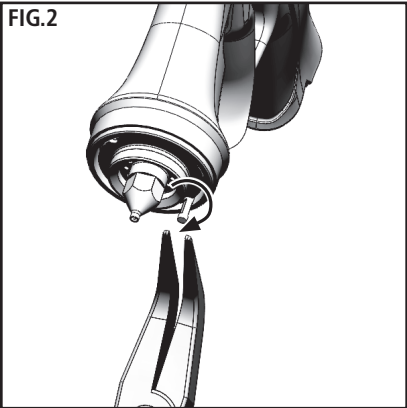
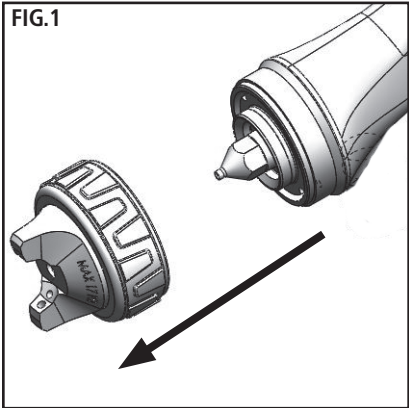



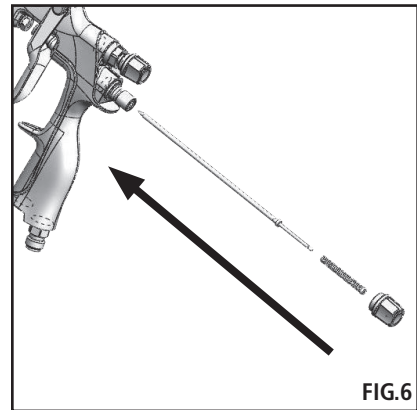
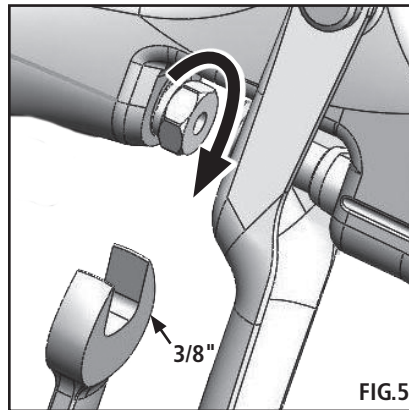
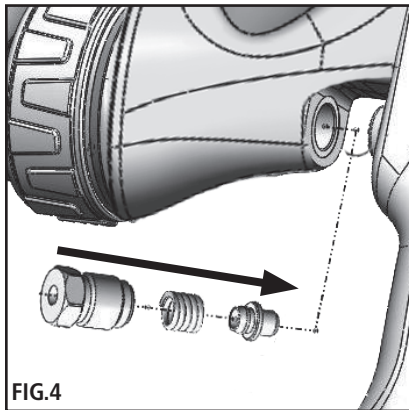
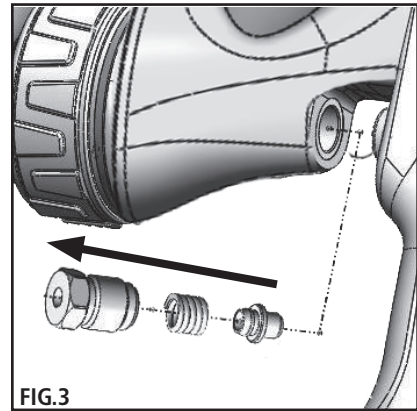
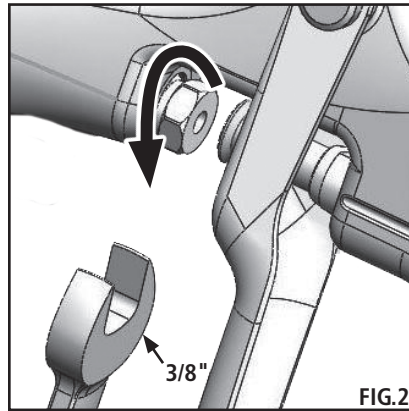
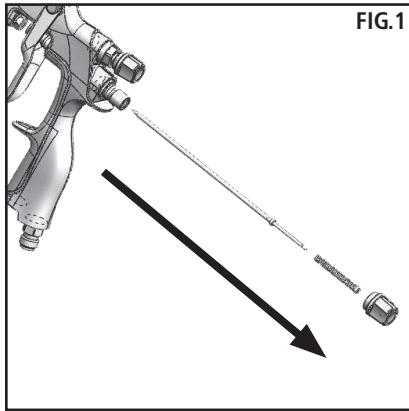

MAINTENANCE – NEEDLE PACKING REMOVAL AND INSTALLATION

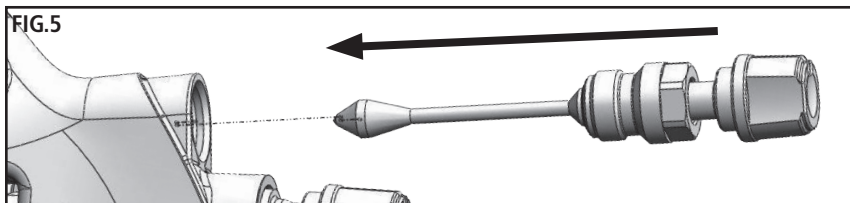
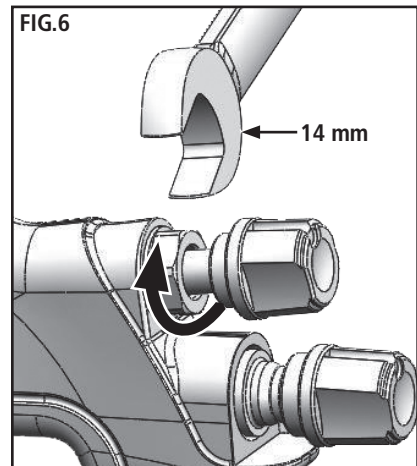
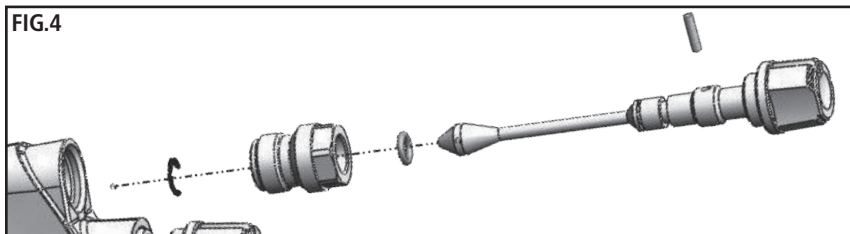
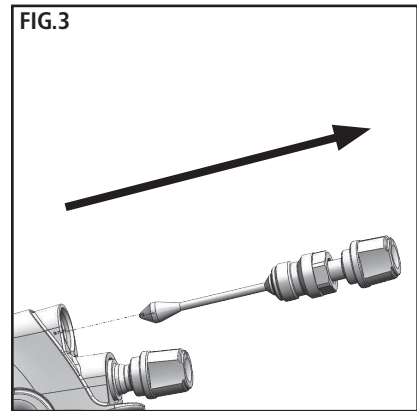
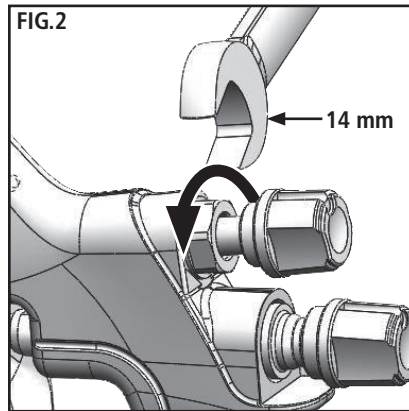
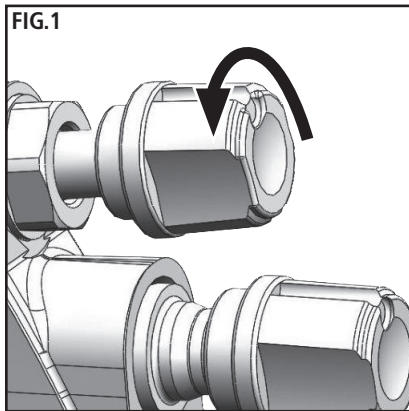

MAINTENANCE – SIDEPORT REMOVAL AND INSTALLATION



TROUBLESHOOTING

CONDITION	CAUSE	CORRECTION
Heavy top or bottom pattern 	Horn holes plugged. Obstruction on top or bottom of fluid tip. Cap and/or tip seat dirty.	Clean. Ream with non-metallic point. Clean. Clean.
Heavy right or left side pattern 	Left or right side horn holes plugged. Dirt on left or right side of fluid tip.	Clean. Ream with non-metallic point. Clean.
	Remedies for the top-heavy, bottom-heavy, right-heavy, and left-heavy patterns: 1. Determine if the obstruction is on the air cap or the fluid tip. Do this by making a test spray pattern. Then, rotate the cap one-half turn and spray another pattern. If the defect is inverted, obstruction is on the air cap. Clean the air cap as previously instructed. 2. If the defect is not inverted, it is on the fluid tip. Check for a fine burr on the edge of the fluid tip. Remove with #600 wet or dry sand paper. 3. Check for dried paint just inside the opening; remove by washing with solvent.	
Heavy center pattern 	Fluid flow too high for atomization air. Material flow exceeds air cap's capacity. Spreader adjustment valve set too low. Atomizing pressure too low. Material too thick.	Balance air pressure and fluid flow. Increase spray pattern width with spreader adjustment valve. Thin or lower fluid flow. Adjust. Increase pressure. Thin to proper consistency.
Split spray pattern 	Atomization air pressure too high. Fluid flow too low. Spreader adjusting valve set too high.	Reduce at transformer or gun. Increase fluid flow (increases gun handling speed). Adjust.
Jerky or fluttering spray 	*Loose or damaged fluid tip/seat. Material level too low. Container tipped too far. Obstruction in fluid passage. Dry or loose fluid needle packing nut.	Tighten or replace. Refill. Hold more upright. Backflush with solvent. Lubricate or tighten.
Unable to get round spray	Spreader adjustment screw not seating properly. Air cap retaining ring loose.	Clean or replace. Tighten.
Will not spray	No air pressure at gun. Fluid needle adjusting screw not open enough. Fluid too heavy for gravity feed.	Check air supply and air lines, blow out gun air passages. Open fluid needle adjusting screw. Thin material and/or change to larger tip size.
Paint bubbles in cup	Fluid tip not tight.	Tighten tip.
Fluid leaking or dripping from cup lid	Cup lid loose. Dirty threads on cup or lid. Cracked cup or lid.	Tighten lid. Clean. Replace cup and lid.

*Most common problem.

TROUBLESHOOTING

CONDITION	CAUSE	CORRECTION
Starved spray pattern	Inadequate material flow. Low atomization air pressure.	Back fluid adjusting screw out to first thread, or change to larger tip size. Increase air pressure and rebalance gun.
Excessive overspray	Too much atomization air pressure. Gun too far from work surface. Improper stroking (arcing, gun motion too fast).	Reduce pressure. Adjust to proper distance. Move at moderate pace, parallel to work surface.
Excessive fog	Too much or too fast-drying thinner. Too much atomization (air pressure.)	Remix properly. Reduce air pressure.
Dry spray	Air pressure too high. Gun tip too far from work surface. Gun motion too fast. Gun out of adjustment.	Reduce air pressure. Adjust to proper distance. Slow down. Adjust.
Fluid leaking from packing nut	Packing nut loose. Packing worn or dry.	Tighten, do not bind needle. Replace or lubricate.
Fluid leaking or dripping from front of gun	Packing nut too tight. Dry packing. Fluid tip or needle worn or damaged. Foreign matter in tip. Fluid needle spring broken. Wrong size needle or tip.	Adjust. Lubricate. Replace tip and needle. Clean. Replace. Replace.
Fluid dripping or leaking from bottom of cup	Cup loose on gun. Cup gasket worn or missing below cup. Cup threads dirty.	Tighten. Replace cup gasket. Clean.
Runs and sags	Too much material flow. Material too thin. Gun tilted on an angle, or gun motion too slow.	Adjust gun or reduce fluid flow. Mix properly or apply light coats. Hold gun at right angle to work and adapt to proper gun technique.
Thin, sandy coarse finish drying before it flows out	Gun too far from surface. Too much air pressure. Improper thinner being used.	Check distance. Normally approximately 8". Reduce air pressure and check spray pattern. Follow paint manufacturer's mixing instructions.
Thick, dimpled finish "orange peel"	Gun too close to surface. Too much material coarsely atomized. Air pressure too low. Improper thinner being used. Material not properly mixed. Surface rough, oily, dirty.	Check distance. Normally approximately 8". Follow paint manufacturer's mixing instructions. Increase air pressure or reduce fluid flow. Follow paint manufacturer's mixing instructions. Follow paint manufacturer's mixing instructions. Follow paint manufacturer's mixing instructions. Properly clean and prepare.

ACCESSORIES

HAF-507-K12 Whirlwind™ In-Line Air Filter Kit of 12

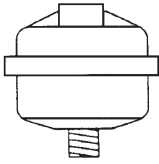

Removes water, oil, and debris from the air line.

192212 Professional Spray Gun Cleaning Kit



Contains six precision tools designed to effectively clean all DeVilbiss, Binks, Finishline and other brand spray guns.

6-429 Binks Gunners Mate Lube (Twenty 2 oz. bottles)



Compatible with all paint materials; contains no silicone or petroleum distillates to contaminate paint. MSDS available upon request.

HAV-500 OR HAV-501 Adjusting Valve (HAV-501 SHOWN)

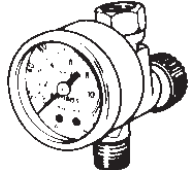

HAV-500 does not have pressure gauge. Use to control air usage at gun.

Millennium 3000 Twin Cartridge Paint Spray Respirator



NIOSH-Certified, for respiratory protection in atmospheres not immediately dangerous to life.

Small 40-141	Medium 40-128	Large 40-143
-----------------	------------------	-----------------

Quick Connects for HVLP Guns (Air) High Flow Type

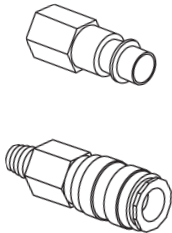

HC-4419 Stem 1/4" NPT(F) Gun End
HC-4719 Coupler 1/4" NPT(M) Hose End

29-3100 Scrubs® Hand Cleaner Towels



Scrubs® are a premoistened hand cleaner towel for painters, body men and mechanics that go where you go and no water is needed.

54-6106 1 Qt. Gravity Cup (Aluminum)

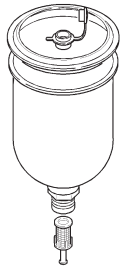

192219 Gun Holder

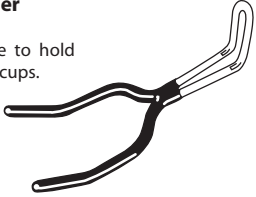

Gun holder made to hold guns with gravity cups.

KGP-13-K5 Cup Gasket







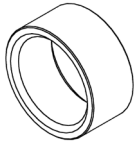











Fluid inlet gasket necessary for use with metal gravity cups.

54-6197 Needle Adjustment Stop



DeKups® Accessories for gravity feed cups

DPC-60-K10 9oz Universal x10 	DPC-59-K10 24oz Universal x10 	DPC-61-K10 34oz Universal x10 	125 µm  DPC-42-K24 x24	200 µm  DPC-66-K24 x24	 DPC-6-K10 x10
			125 µm  DPC-65-K24 x24	200 µm  DPC-67-K24 x24	 DPC-22-K24 x24
 DPC-607 x2	 DPC-606 x2	 DPC-608 x2	 9 FL 265 mL DPC-602 x32	 24 FL 710 mL DPC-601 x32	 DPC-44
			 34 FL 1000 mL DPC-600 x32		 DPC-31
SHELLS			LINERS		

WARRANTY POLICY

Binks products are covered by Carlisle Fluid Technologies one year materials and workmanship limited warranty. The use of any parts or accessories, from a source other than Carlisle Fluid Technologies, will void all warranties. For specific warranty information please contact the closest Carlisle Fluid Technologies location listed below.

Carlisle Fluid Technologies reserves the right to modify equipment specifications without prior notice. DeVilbiss®, Ransburg®, MS®, BGK®, and Binks® are registered trademarks of Carlisle Fluid Technologies, Inc. ©2017 Carlisle Fluid Technologies, Inc. All rights reserved.



Binks is part of Carlisle Fluid Technologies, a global leader in innovative finishing technologies. For technical assistance or to locate an authorized distributor, contact one of our international sales and customer support locations.

USA/Canada

info@carlisleleft.com
Tel: 1-888-992-4657
Fax: 1-888-246-5732

Mexico

ventas@carlisleleft.com.mx
Tel: 011 52 55 5321 2300
Fax: 011 52 55 5310 4790

Brazil

vendas@carlisleleft.com.br
Tel: +55 11 5641 2776
Fax: 55 11 5641 1256

United Kingdom

info@carlisleleft.eu
Tel: +44 (0)1202 571 111
Fax: +44 (0)1202 573 488

France

info@carlisleleft.eu
Tel: +33(0)475 75 27 00
Fax: +33(0)475 75 27 59

Germany

info@carlisleleft.eu
Tel: +49 (0) 6074 403 1
Fax: +49 (0) 6074 403 281

China

mkt@carlisleleft.com.cn
Tel: +8621-3373 0108
Fax: +8621-3373 0308

Japan

overseas-sales@carlisleleft.co.jp
Tel: 081 45 785 6421
Fax: 081 45 785 6517

Australia

sales@carlisleleft.com.au
Tel: +61 (0) 2 8525 7555
Fax: +61 (0) 2 8525 7575

For the latest information about our products, visit www.carlisleleft.com.



SERIE "TROPHY" DE BINKS
PISTOLAS PULVERIZADORAS MANUALES DE
ALIMENTACIÓN A GRAVEDAD
HVLP, LVMP Y CONVENCIONALES



(2466-XXXX-XXXX)

CE  II 2 G X

La pistola pulverizadora de alimentación a gravedad Serie "Trophy" de Binks es la principal pistola pulverizadora para uso en aplicaciones de pulverización de alimentación a gravedad y fija nuevos estándares de durabilidad, ergonomía y atomización. El diseño ergonómico liviano ofrece comodidad y control insuperables. Se ha incorporado la más avanzada tecnología de atomización para lograr acabados finos consistentes al atomizar una amplia gama de aplicaciones de recubrimiento industrial.

Las pistolas pulverizadoras de alimentación a gravedad Serie "Trophy" de Binks se pueden usar con bombas, recipientes de presión, cubetas de presión o cubetas del sifón.



ESPECIFICACIONES

Las pistolas pulverizadoras Serie HVLP "Trophy" se pueden usar para operar con altas eficiencias de transferencia en cumplimiento con las regulaciones del "Distrito para el control de la calidad del aire de la Costa Sur de California" como una pistola pulverizadora de alto volumen, baja presión.

Presión máxima del aire	140 psi / 9.6 bar (P-1)
Cuerpo de la pistola	Aluminio anodizado
Conducto del fluido	Acero inoxidable
Tamaño del orificio de entrada del fluido	3/8" - 19 NPS / BSP(f)
Tamaño del orificio de entrada del aire	1/4" NPS / BSP(m)
Peso de la pistola	13.8 oz. / 394 gramos (sin cubeta)
Piezas humedecidas	Acero inoxidable y PTFE

¡IMPORTANTE! NO DESTRUIR

Es responsabilidad del cliente que todos los operadores y miembros del personal de servicios lean y comprendan este manual. Para obtener copias adicionales de este manual, favor ponerse en contacto con un representante de Binks de su localidad.

LEA TODAS LAS INSTRUCCIONES ANTES DE OPERAR ESTE PRODUCTO BINKS.

En esta Hoja de piezas, las palabras **ADVERTENCIA**, **PRECAUCIÓN** y **NOTA** se emplean para enfatizar información de seguridad importante de la siguiente forma:

⚠ ADVERTENCIA
Prácticas peligrosas o inseguras que pueden ocasionar lesiones personales graves, la muerte o daño substancial a la propiedad.

⚠ PRECAUCIÓN
Prácticas peligrosas o inseguras que pueden ocasionar lesiones personales leves, la muerte, daño al producto o a la propiedad.

NOTA
Información importante de instalación, operación o mantenimiento.

⚠ ADVERTENCIA

Lea las siguientes advertencias antes de usar este equipo.



LEA EL MANUAL
Antes de operar los equipos de acabado, lea y comprenda toda la información de seguridad, operación y mantenimiento incluida en el manual de operaciones.



USE GAFAS PROTECTORAS
No usar gafas protectoras con resguardos laterales puede ocasionar lesiones graves en los ojos o ceguera.



DESACTIVE, DESPRESURICE, DESCONECTE Y BLOQUEE TODAS LAS FUENTES DE ENERGÍA DURANTE EL MANTENIMIENTO.
No desactivar, desconectar ni bloquear todas las fuentes de suministro de energía antes de realizar operaciones de mantenimiento en los equipos puede ocasionar lesiones graves o la muerte.



CAPACITACIÓN DE LOS OPERADORES
Todos los miembros del personal deben ser capacitados antes de operar los equipos de acabado.



PELIGRO POR USO INDEBIDO DEL EQUIPO
El uso indebido del equipo puede ocasionar averías, mal funcionamiento o activación imprevista lo que a su vez puede producir lesiones graves.



MANTENGA LAS DEFENSAS DEL EQUIPO EN SU LUGAR.
No operar los equipos si los dispositivos de seguridad fueron retirados.

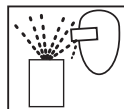

PELIGRO DE PROYECTILES
Usted puede resultar lesionado por dar salida a líquidos o gases liberados bajo presión o por restos que vuelan.



PELIGRO DE PUNTOS DE PRESIÓN
Las partes móviles pueden aplastar y ocasionar cortaduras. Los puntos de presión son básicamente todas las áreas donde haya partes móviles.



INSPECCIONE LOS EQUIPOS DIARIAMENTE
Inspeccione diariamente los equipos para verificar que no tengan piezas gastadas o rotas. No opere los equipos si no está seguro de esta condición.



NUNCA MODIFIQUE LOS EQUIPOS
No modifique el equipo sin la autorización escrita del fabricante.



SEPA CÓMO Y DÓNDE DESACTIVAR LOS EQUIPOS EN CASO DE EMERGENCIA.



PROCEDIMIENTO DE LIBERACIÓN DE PRESIÓN
Siga siempre el procedimiento de liberación de presión que aparece en el manual de instrucciones del equipo.



PELIGRO DE RUIDO
Usted puede resultar lesionado por el ruido muy fuerte. Podría necesitar protección de los oídos al usar este equipo.



CARGA ESTÁTICA
Los fluidos pueden generar una carga estática que debe ser disipada mediante la debida conexión a tierra del equipo, los objetos que van a ser atomizados y todos los demás objetos electroconductores en el área de aplicación. La conexión a tierra indebida o las chispas pueden ocasionar condiciones de peligro y producir incendios, explosiones o descargas eléctricas y otras lesiones graves.



PELIGRO DE INCENDIO Y EXPLOSIÓN
Nunca use 1, 1,1-tricloroetano, cloruro de metileno, otros disolventes con hidrocarburos halogenados o fluidos que contengan dichos disolventes en equipos con piezas de aluminio humedecidas. Tales usos pueden producir una reacción química peligrosa con posibilidades de explosión. Consulte con sus proveedores de fluidos para asegurarse de que los fluidos que se vayan a usar sean compatibles con las piezas de aluminio.



ADVERTENCIA PROP 65 DE CA
ADVERTENCIA: Este producto contiene sustancias químicas que según información en poder del estado de California producen cáncer, defectos de nacimiento y otros daños al sistema reproductor.

Descripción del producto / Objeto de la Declaración :	Trophy
Este Producto está diseñado para su uso con:	Materiales de base de agua y disolventes
Adecuado para su uso en áreas peligrosas:	Zona 1 / Zona 2
Nivel de protección:	II 2 G X
Notificado de carrocería y papel :	TRAC Global Ltd (0891) Presentación de Ficha técnica
Esta declaración de conformidad / incorporación se expide bajo la exclusiva responsabilidad del fabricante:	Carlisle Fluid Technologies, 320 Phillips Ave., Toledo, OH 43612

Declaración de conformidad EU



El objeto de la declaración descrita anteriormente es conforme con la legislación de armonización de la Unión pertinente :

Directiva de máquinas 2006/42/CE

Directiva ATEX 2014/34/EU

ya que es conforme con las siguientes normas armonizadas y documentos estatutarios:

EN ISO 12100:2010 Seguridad de las máquinas - Principios generales para el diseño

BS EN 1953:2013 Equipos de atomización y pulverización para materiales de recubrimiento - Requisitos de seguridad

EN 1127-1:2011 Atmósferas explosivas - Prevención contra la explosión - Conceptos básicos

EN 13463-1:2009 Equipos no eléctricos destinados a atmósferas potencialmente explosivas - Requisitos y metodología básica

Proporcionar todas las condiciones de uso seguro / instalación indicado en los manuales de los productos se han cumplido y también se instala de acuerdo con todos los códigos locales aplicables de la práctica .

Firmado por y en nombre de
Carlisle Fluid Technologies:

DJ Hasselschwert
11-Jul-16

(Vicepresidente : Desarrollo
Global de Productos)

Toledo, OH 43612

PISTOLA PULVERIZADORA DE ALIMENTACIÓN A GRAVEDAD SERIE "TROPHY" DE BINKS

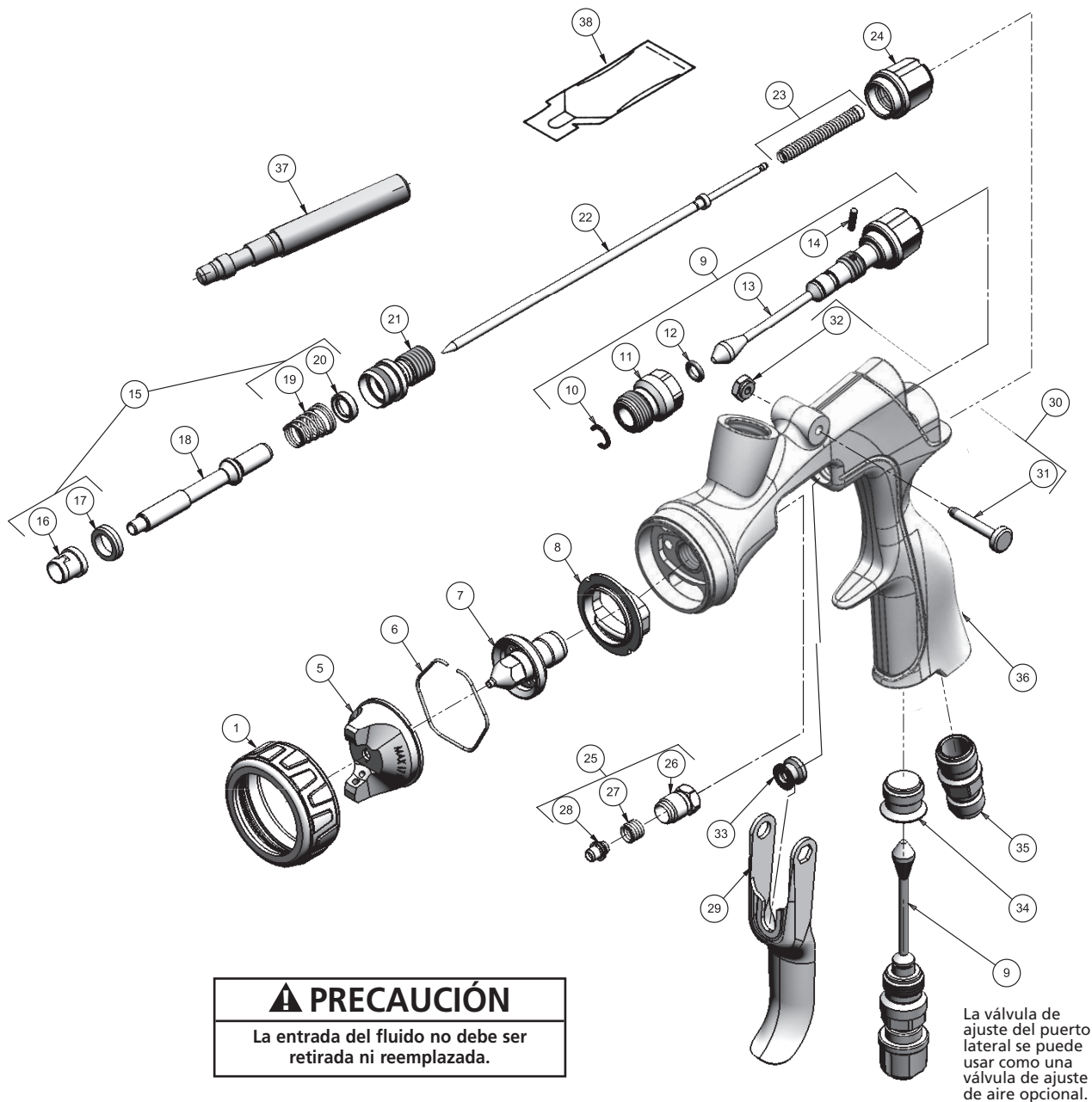

SISTEMA DE NUMERACIÓN PARA PISTOLAS PULVERIZADORAS DE ALIMENTACIÓN A GRAVEDAD SERIE "TROPHY" TAMAÑO ESTÁNDAR DE BINKS

2466 - XXXX - XXXX

PISTOLA A GRAVEDAD

TAMAÑOS DE ORIFICIOS
 12 1.2 MM
 14 1.4 MM
 16 1.6 MM
 18 1.8 MM

TECNOLOGÍA DE AUTOMATIZACIÓN
 CN CONVENCIONAL
 LV LVMP
 HV HVLP

DESIGNACIÓN DE CUBETA
 0 SIN CUBETA
 G CUBETA DEL GRAVEDAD

MATERIAL DE LA AGUJA
 S ACERO INOXIDABLE (ENDURECIDO)

DESIGNACION DE LA CUBIERTA DE AIRE
 Serie 10 CONVENCIONAL
 Serie 20 LVMP
 Serie 30 HVLP

Consulte las tablas en la página 6 para las ensamblas de armas completas.

TABLA 1: LISTA DE PIEZAS DE LA PISTOLA PULVERIZADORA DE ALIMENTACIÓN A GRAVEDAD SERIE "TROPHY" DE BINKS

NÚM. DE ART.	NÚM. DE PIEZA	DESCRIPCIÓN	CANT.	NÚM. DE ART.	NÚM. DE PIEZA	DESCRIPCIÓN	CANT.
1	54-6120	CONJUNTO DEL ANILLO DE RETENCIÓN DE LA CUBIERTA DE AIRE	1	24	54-6111	PERILLA – AJUSTE DE LA AGUJA	1
5	VER TABLAS EN LA PÁGINA 7	CUBIERTA DE AIRE	1	25	54-6130-K	KIT DE LA EMPAQUETADURA DE LA AGUJA (ESTÁNDAR)	1
6	JGA-156-K10	SUJETADOR DE MUELLE (KIT DE 10)	1	26	-----	■ TUERCA – EMPAQUETADURA	1
7	VER TABLAS A CONTINUACIÓN	BOQUILLA DE FLUIDO	1	27	-----	■ MUELLE PARA EMPAQUETADURA	1
8	54-6102-K3	DEFLECTOR/SEPARADOR (KIT DE 3)	1	28	-----	□ ■ ▼ EMPAQUETADURA DE LA AGUJA (ESTÁNDAR)	1
9	54-6122	CONJUNTO DE VÁLVULA DEL PUERTO LATERAL	1	29	54-4360	DISPARADOR	1
10	-----	+ Δ SUJETADOR DE RETENCIÓN	1	30	54-6132-K	KIT DE LA TUERCA DE ROSCA DEL DISPARADOR	1
11	-----	+ MANGUITO DEL CUERPO	1	31	-----	○ TORNILLO DEL DISPARADOR	1
12	-----	+ Δ JUNTA TÓRICA	1	32	-----	○ TUERCA DEL DISPARADOR	1
13	-----	+ VÁSTAGO DEL PUERTO LATERAL	1	33	54-3513	HUSILLO DE LA CUBIERTA	1
14	-----	+ Δ CLAVIJA	1	34	SN-11	TAPÓN	1
15	54-6131-K	□ KIT DE SERVICIO DE LA VÁLVULA DE AIRE	1	35	54-6112	ACCESORIO – ORIFICIO DE ENTRADA DEL AIRE	1
16	-----	• SELLO DELANTERO – VÁLVULA DE AIRE	1	36	-----	CUERPO DE LA PISTOLA CON ORIFICIO DE ENTRADA DEL FLUIDO	1
17	-----	• SELLO DELANTERO DE LA VÁLVULA DE AIRE	1	37	-----	HERRAMIENTA – INSERCIÓN DEL SELLO	1
18	54-6109	□ HUSILLO DE LA VÁLVULA DE AIRE	1	38	-----	GUNNER'S MATE (BOLSA DE 3 CC)	1
19	-----	• MUELLE DE LA VÁLVULA DE AIRE	1				
20	-----	• SELLO TRASERO – VÁLVULA DE AIRE	1				
21	SN-66	ALOJAMIENTO	1				
22	47-6825	AGUJA – ACERO INOXIDABLE (ESTÁNDAR)	1				
23	-----	□ CONJUNTO DE MUELLE/ALMOHADILLA	1				
	54-6133-K3	CONJUNTO DE MUELLE/ALMOHADILLA (ESTÁNDAR) (KIT DE 3)	1				

+	LAS PIEZAS ESTÁN INCLUIDAS EN 54-6122
■	LAS PIEZAS ESTÁN INCLUIDAS EN 54-6130-K
▼	TAMBIÉN DISPONIBLE EN KIT DE 3 SN-2-K3
•	LAS PIEZAS ESTÁN INCLUIDAS EN 54-6131-K

○	LAS PIEZAS ESTÁN INCLUIDAS EN 54-6132-K
Δ	GTI-428-K5 KIT DE REPARACIÓN DEL PUERTO LATERAL
□	LAS PIEZAS ESTÁN INCLUIDAS EN 54-6135

TABLA 2: BOQUILLAS DE FLUIDO DE ACERO INOXIDABLE (ENDURECIDO) – ESTÁNDAR.

TAMAÑO DEL ORIFICIO DE LA BOQUILLA DE FLUIDO DE ACERO INOXIDABLE	NÚM. DE PIEZA DE BOQUILLA DE FLUIDO
.039"	1.0 mm 45-11050-10
.047"	1.2 mm 45-11050-12
.055"	1.4 mm 45-11050-14
.063"	1.6 mm 45-11050-16
.071"	1.8 mm 45-11050-18

TABLA 3: KITS DE PRUEBA DE CUBIERTA DE AIRE – OPCIONAL

CONVENCIONAL	
54-6141-K	12-C KIT
LVMP	
54-6147-K	23-L KIT
HVLP	
54-6152-K	32-H KIT – HVLP

**PISTOLA PULVERIZADORA SERIE "TROPHY" DE BINKS
GUÍA DE SELECCIÓN DE AGUJA Y BOQUILLA PARA PISTOLA PULVERIZADORA DE
ALIMENTACIÓN A GRAVEDAD**

**TABLA 4: CONFIGURACIONES DE
PISTOLAS CONVENCIONALES**

TIPO DE FLUIDO QUE VA A SER ATOMIZADO	NÚM. DE PIEZA DEL CONJUNTO COMPLETO DE LA PISTOLA	BOQUILLA DE FLUIDO Y CUBIERTA DE AIRE
DILUIDO 5-25 CENTIPOISES Taza Zahn "2" 15-19 seg. imprimadores de lavado, tintes, barnices, disolventes, agua, tintas, selladores, lacas, lubricantes, cromatos de zinc, acrílicos	2466-14CN-12SG	1.4 mm (.055") X 12C
	2466-16CN-12SG	1.6 mm (.063") X 12C
MEDIANO 25-70 CENTIPOISES Taza Zahn "2" 20-30 seg. esmaltes sintéticos, barnices, gomas lacas, rellenos, imprimadores, epoxis, uretano, lubricantes, emulsiones de cera, esmaltes	2466-16CN-12SG	1.6 mm (.063") X 12C
	2466-18CN-12SG	1.8 mm (.070") X 12C

TABLA 5: CONFIGURACIONES DE PISTOLAS LVMP

TIPO DE FLUIDO QUE VA A SER ATOMIZADO	NÚM. DE PIEZA DEL CONJUNTO COMPLETO DE LA PISTOLA	BOQUILLA DE FLUIDO Y CUBIERTA DE AIRE
DILUIDO 5-25 CENTIPOISES Taza Zahn "2" 15-19 seg. imprimadores de lavado, tintes, barnices, disolventes, agua, tintas, selladores, lacas, lubricantes, cromatos de zinc, acrílicos	2466-12LV-23SG	1.2 mm (.067") X 23L
	2466-14LV-23SG	1.4 mm (.055") X 23L
MEDIANO 25-70 CENTIPOISES Taza Zahn "2" 20-30 seg. esmaltes sintéticos, barnices, gomas lacas, rellenos, imprimadores, epoxis, uretano, lubricantes, emulsiones de cera, esmaltes	2466-14LV-23SG	1.4 mm (.055") X 23L
	2466-18LV-23SG	1.8 mm (.070") X 23L

TABLA 6: CONFIGURACIONES DE PISTOLAS HVLP

TIPO DE FLUIDO QUE VA A SER ATOMIZADO	NÚM. DE PIEZA DEL CONJUNTO COMPLETO DE LA PISTOLA	BOQUILLA DE FLUIDO Y CUBIERTA DE AIRE
DILUIDO 5-25 CENTIPOISES Taza Zahn "2" 15-19 seg. imprimadores de lavado, tintes, barnices, disolventes, agua, tintas, selladores, lacas, lubricantes, cromatos de zinc, acrílicos	2466-12HV-32SG	1.2 mm (.047") X 32H
	2466-14HV-32SG	1.4 mm (.055") X 32H
MEDIANO 25-70 CENTIPOISES Taza Zahn "2" 20-30 seg. esmaltes sintéticos, barnices, gomas lacas, rellenos, imprimadores, epoxis, uretano, lubricantes, emulsiones de cera, esmaltes	2466-14HV-32SG	1.4 mm (.055") X 32H
	2466-18HV-32SG	1.8 mm (.070") X 32H

PISTOLA PULVERIZADORA SERIE "TROPHY" DE BINKS
TABLA DE SELECCIÓN DE CUBIERTA DE AIRE Y BOQUILLA DE FLUIDO PARA PISTOLA
PULVERIZADORA DE ALIMENTACIÓN A GRAVEDAD

TABLA 7: TABLA DE SELECCIÓN DE CUBIERTA DEL AIRE Y BOQUILLA DE FLUIDO CONVENCIONALES

Cubierta de aire	Núm. de pieza de la cubierta de aire	Rango del patrón de pulverización	CFM @ 30 PSI	CFM @ 50 PSI	CFM @ 70 PSI	Boquilla de fluido	Recubrimientos típicos
12-C	46-6501	4 – 12"	8.3	12.1	14.2	serie 45-11050, 1.2 mm – 1.8 mm	Lacas, esmaltes, recubrimientos superiores, adhesivos de baja viscosidad

TABLA 8: TABLA DE SELECCIÓN DE CUBIERTA DEL AIRE Y BOQUILLA DE FLUIDO DE BAJO VOLUMEN Y PRESIÓN MEDIANA – LVMP

Cubierta de aire	Núm. de pieza de la cubierta de aire	Rango del patrón de pulverización	Orificio de entrada de la pistola CFM @30 PSI (dinámico)	Boquilla de fluido	Recubrimientos típicos
23-L	46-6511	4 – 12"	10.6	serie 45-11050, 1.2 mm – 1.8 mm	Lacas, esmaltes, recubrimientos superiores, adhesivos de baja viscosidad
24-L	46-6512	2 – 6"	14.3	serie 45-11050, 1.0 mm – 1.8 mm	Pequeñas aplicaciones patrón de manchas, lacas, esmaltes, acrílicos

TABLA 9: TABLA DE SELECCIÓN DE CUBIERTA DEL AIRE Y BOQUILLA DE FLUIDO DE ALTO VOLUMEN Y BAJA PRESIÓN – HVLP

Cubierta de aire	Núm. de pieza de la cubierta de aire	Rango del patrón de pulverización	Presión de la cubierta (dinámica) SCFM @ 10 PSI	Orificio de entrada de la pistola PSI @ 10 PSI en la cubierta del aire (dinámica)	Boquilla de fluido	Recubrimientos típicos
32-H	46-6518	8 – 14"	15.5	26	serie 45-11050, 1.2 mm – 1.8 mm	Lacas, esmaltes, multicolores, multi-spec, revestimiento antiadherente, látex cortado

TABLA 10: TABLA DE SELECCIÓN DE CUBIERTA DE AIRE Y BOQUILLA DE FLUIDO DE ATOMIZACIÓN REDONDEADA (OPCIONAL)

Cubierta de aire	Núm. de pieza de la cubierta de aire	Rango del patrón de pulverización	CFM @ 30 PSI	CFM @ 50 PSI	CFM @ 70 PSI	Boquilla de fluido	Recubrimientos típicos
16	46-6505	2 – 4"	5.6	7.8	10.5	serie 45-11050, 1.2 mm – 1.8 mm	Lacas, esmaltes

TIPOS DE INSTALACIÓN

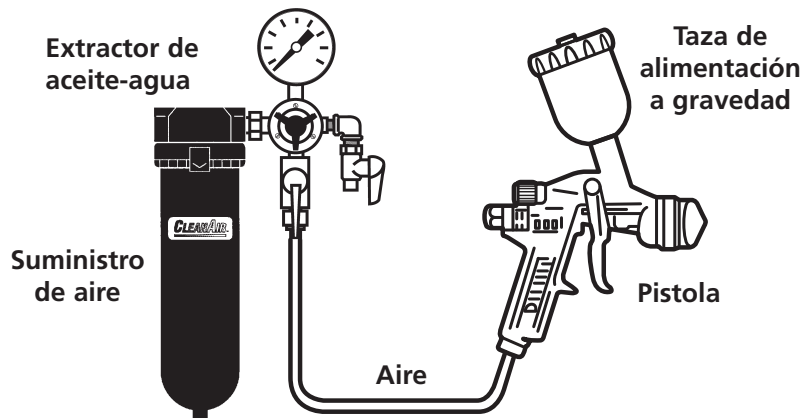

La presión de aire para atomización se regula en el extractor. El flujo del fluido es ajustado por la perilla de control de la válvula de fluido en la pistola, la viscosidad de la pintura y la presión de aire.

ENGANCHE DE LA ALIMENTACIÓN A GRAVEDAD

En las pistolas de alimentación por gravedad de la copa se encuentra por encima de la pistola. La fuerza de la gravedad empuja el fluido en la pistola.

Ventajas: Este método ofrece cambios rápidos de color y la comodidad en trabajos pequeños o retoque aplicaciones. Pistolas de pulverización por gravedad son capaces de utilizar todos los residuos de revestimiento de reducción.

PRESIÓN DEL AIRE

La presión de atomización se debe ajustar debidamente para permitir la caída de la presión de aire entre el regulador y la pistola pulverizadora.

CON PRESIÓN DE AIRE DE 60 PSI APLICADA EN EL SUMINISTRO DE AIRE

Vista en corte transversal que ilustra una comparación de los diámetros internos de la manguera (tamaño real). Presión regulada de 60 lbs.

5/16"

1/4"

RECOMENDADO

48 PSI en orificio de entrada de la pistola

Una manguera de 25 pies con D.I. de 5/16" causa una caída de presión de 12 PSI entre el suministro de aire y la pistola. Por este motivo Binks recomienda el uso de una manguera de 5/16".

NO RECOMENDADO

Sólo 34 PSI en el orificio de entrada de la pistola

Una manguera de 25 pies con D.I. de 1/4" causa una caída de presión de 26 PSI entre el suministro de aire y la pistola.

Un separador de agua y aceite es importante.

Lograr un acabado de rociado fino sin el uso de un buen extractor de aceite-agua es prácticamente imposible.

Un regulador/extractor permite lograr un doble propósito. Elimina la formación de burbujas y las manchas manteniendo el aire libre de aceite y agua y permitiendo un control preciso de la presión de aire en la pistola.

Use extractores y reguladores de agua y aceite DeVilbiss. Consulte la disponibilidad de modelos con el distribuidor de su localidad.

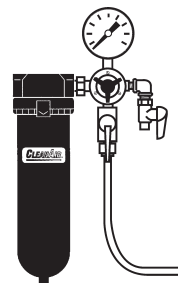

INSTRUCCIONES DE INSTALACIÓN

Para lograr la máxima eficiencia de transferencia, no utilice más presión que la necesaria para atomizar el material que está siendo aplicado.

NOTA

Al usar HVLP no sobrepase las presiones de entrada indicadas en la página 7.

1. Conecte la pistola a un suministro de aire limpio, libre de humedad y aceite usando una manguera conductiva que tenga por lo menos un D.I. de 5/16".

NOTA

Dependiendo de la longitud de la manguera, podría ser necesaria una manguera con mayor D.I. Instale un calibrador neumático en el mango de la pistola. Ver las presiones de operación en la página 7. No utilice más presión que la necesaria para atomizar el material que está siendo aplicado. El exceso de presión creará una sobrepulverización adicional y reducirá la eficiencia de la transferencia.

NOTA

Si se necesitan acopladores de conexión rápida, use sólo acopladores de conexión rápida de flujo alto aprobados para uso con modelos HVLP. Otros tipos no harán fluir suficiente aire para la operación correcta de la pistola.

NOTA

Si se usa una válvula de ajuste de aire en la entrada de la pistola, use la válvula de ajuste HAV-501.

NOTA

Antes de usar la pistola pulverizadora, lávela con solvente para asegurar que los conductos de fluido estén limpios.

OPERACIÓN

MODELOS A GRAVEDAD

1. Mezcle el material de recubrimiento según las instrucciones del fabricante y filtre el material.
2. Llene la cubeta hasta no más de $\frac{3}{4}$ de pulgada desde la parte superior de la cubeta. **NO LLENE EN EXCESO.**
3. Fíjela a la tapa de la cubeta.
4. Gire la perilla de ajuste de fluido (24) en sentido horario para impedir el movimiento de la aguja de fluido.
5. Gire el control del puerto lateral (9) en sentido antihorario hasta que esté totalmente abierto.
6. Ajuste la presión de aire de entrada si fuese necesario.
7. Haga girar la perilla de ajuste de fluido en sentido antihorario hasta que se pueda ver la primera rosca.
8. Prueba de atomizado. Si el acabado está muy seco, reduzca el flujo de aire reduciendo la presión de entrada de aire.

9. Si el acabado es muy húmedo, reduzca el flujo de fluido girando la perilla de ajuste de fluido (24) en sentido horario. Si la atomización es muy gruesa, aumente la presión de entrada. Si es muy fina, reduzca la presión de entrada.
10. Se puede reducir el tamaño del patrón de atomizado girando el control del puerto lateral (9) en sentido horario.
11. Sostenga la pistola perpendicularmente a la superficie que está siendo atomizada. Arquear o inclinar la pistola puede producir un recubrimiento disparejo.
12. La distancia de rociado recomendada es de 8 pulgadas.
13. Rocíe los bordes primero. Superponga cada recorrido de atomizado al menos un 75%. Mueva la pistola a velocidad constante.
14. Interrumpa siempre el suministro de aire y reduzca la presión cuando la pistola no esté en uso.

MANTENIMIENTO PREVENTIVO Y LIMPIEZA

Para limpiar la cubierta de aire y la boquilla de fluido, cepille el exterior con un cepillo de cerdas duras. Si fuese necesario limpie los orificios de la cubierta, use una paja de escoba o un mondadientes si fuese posible. Si se usa alambre o un instrumento duro, se debe tener mucho cuidado para evitar rayar o formar rebabas en los bordes de los orificios lo que distorsionaría los patrones de pulverización.

Para limpiar los conductos de fluido, elimine el material excedente de la pistola y limpie con solución para lavar pistolas. Limpie el exterior de la pistola con un paño humedecido. Nunca sumerja completamente la pistola en ningún solvente o solución limpiadora porque esto es perjudicial para los lubricantes y la vida útil de la pistola pulverizadora.

NOTA

Al reemplazar la boquilla de fluido (7) o la aguja de fluido (22), reemplace ambas al mismo tiempo. El uso de partes gastadas puede ocasionar la filtración de fluido. Vea la página 4. Además, reemplace la empaquetadura de la aguja en este momento. Aplique torsión de 230–240 pulg-lbs a la boquilla de fluido. No los apriete demasiado.

PRECAUCIÓN

Para evitar dañar la boquilla de fluido (7) o la aguja de fluido (22), asegúrese de 1) tirar del disparador y mantenerlo activado mientras aprieta o afloja la boquilla de fluido, o 2) quitar la perilla de ajuste de fluido (24) para reducir la presión del muelle contra el collar de la aguja.

CUBETA DEL GRAVEDAD. Vacíe el material sobrante y limpie la cubeta. Asegúrese de que el orificio de ventilación en la tapa no esté bloqueado.

PROCEDIMIENTOS DE REMOCIÓN E INSTALACIÓN

DESENSAMBLAJE Y ENSAMBLAJE DE LA AGUJA Y VÁLVULA

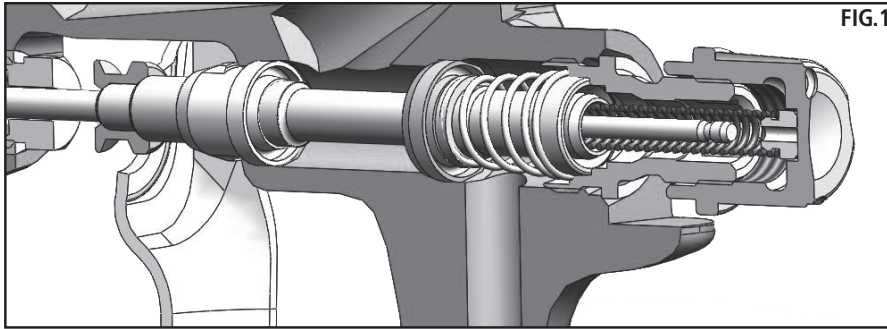

DESENSAMBLAJE

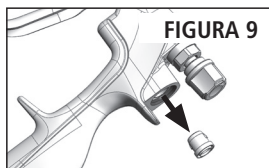
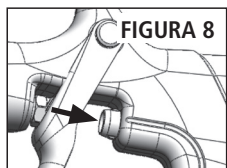
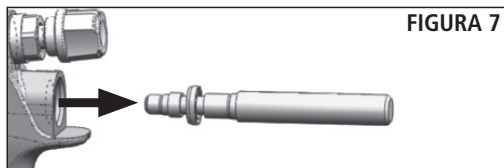
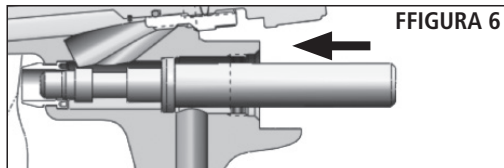
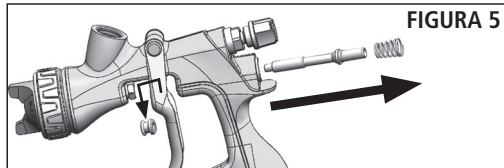
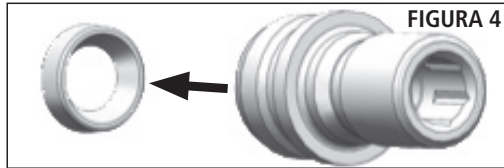
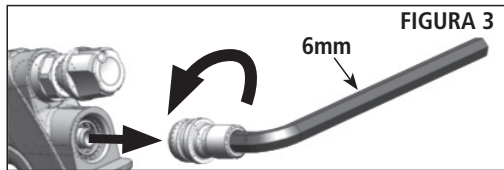
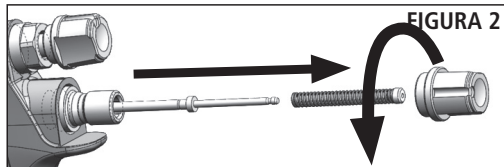

ENSAMBLAJE

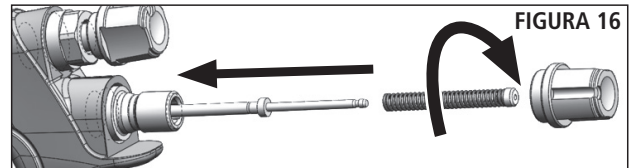
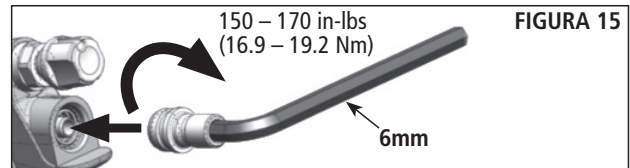
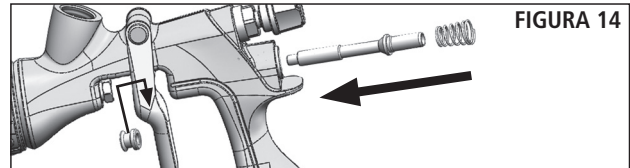
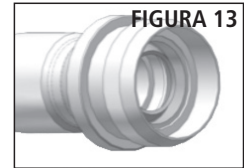
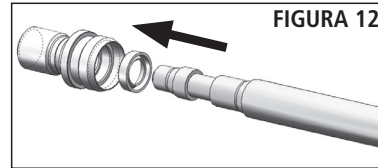
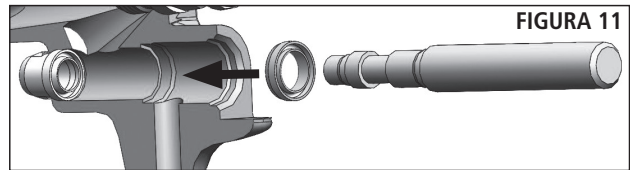
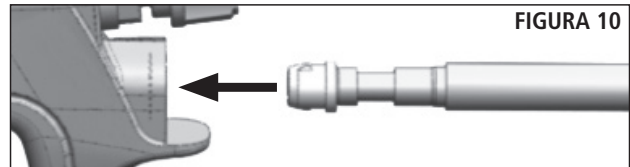

MANTENIMIENTO – REMOCIÓN E INSTALACIÓN DE LA BOQUILLA DE FLUIDO Y EL DEFLECTOR

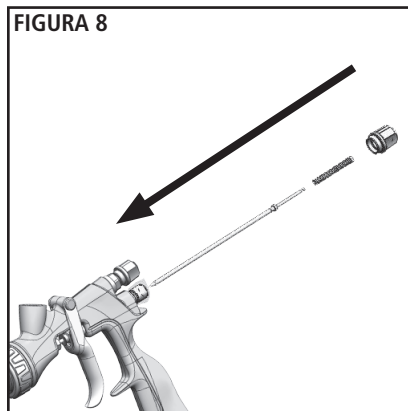
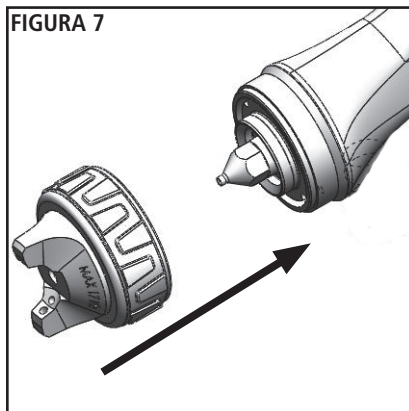
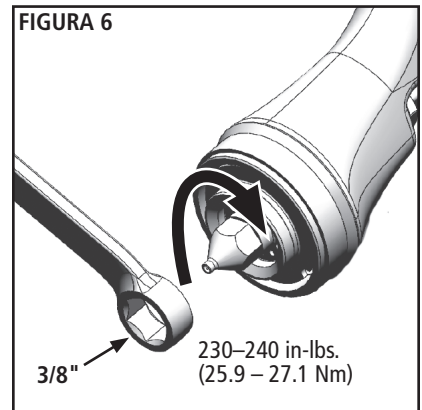
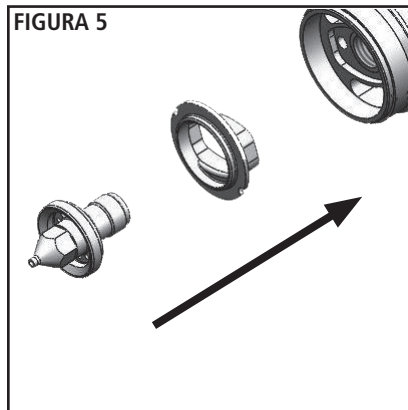
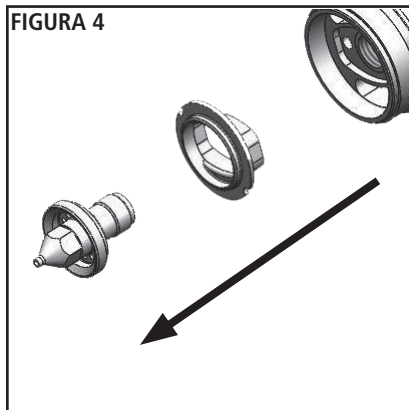
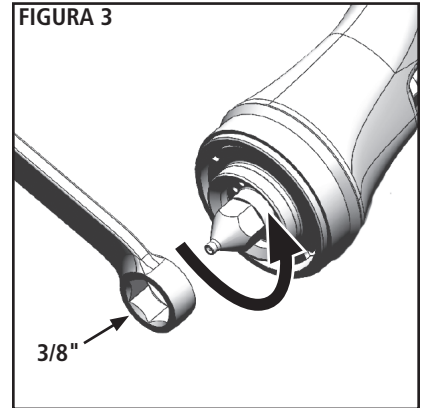
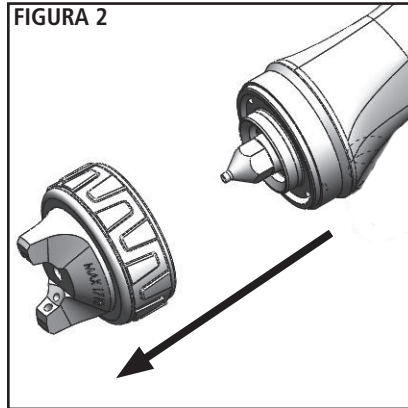
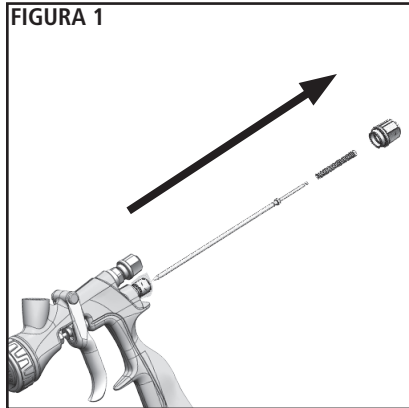

INSTALACIÓN DE LA CLAVIJA DE INDEXACIÓN DE LA CUBIERTA DEL AIRE (OPCIONAL – CARACTERÍSTICA DE INDEXACIÓN EN INCREMENTOS DE 90°)

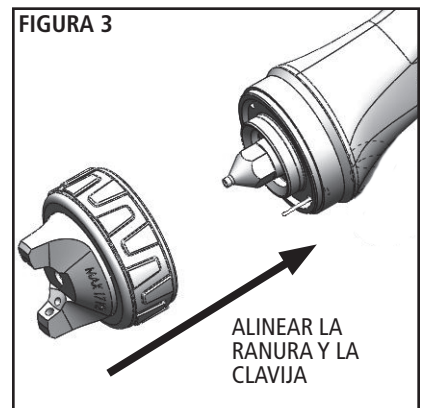
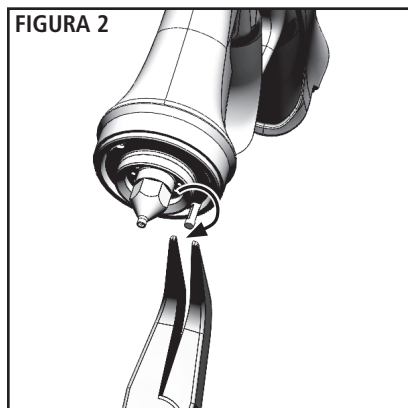
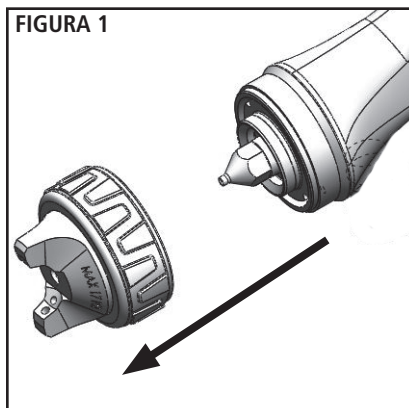



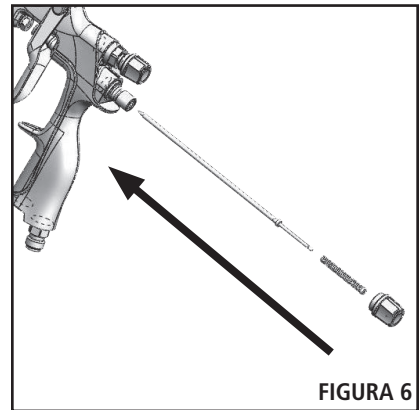
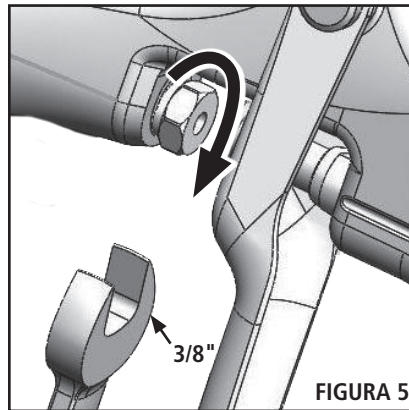
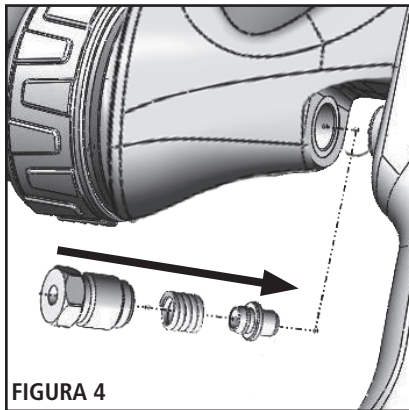
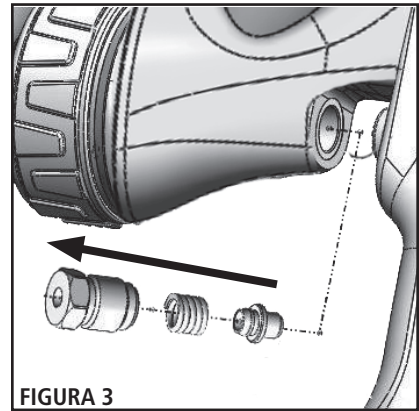
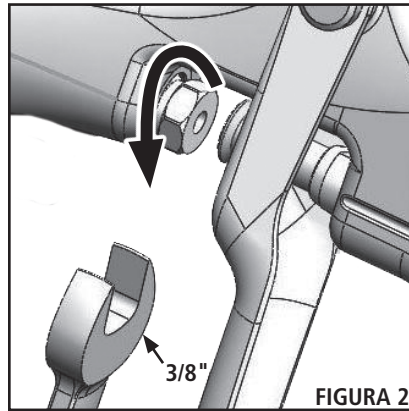
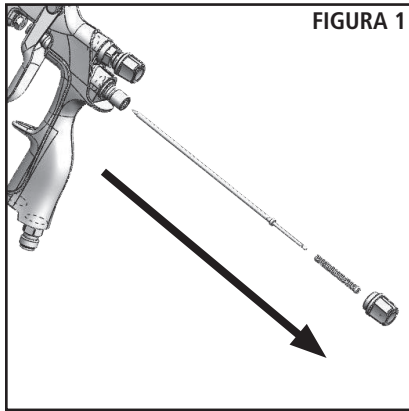

MANTENIMIENTO – REMOCIÓN E INSTALACIÓN DE LA EMPAQUETADURA DE LA AGUJA

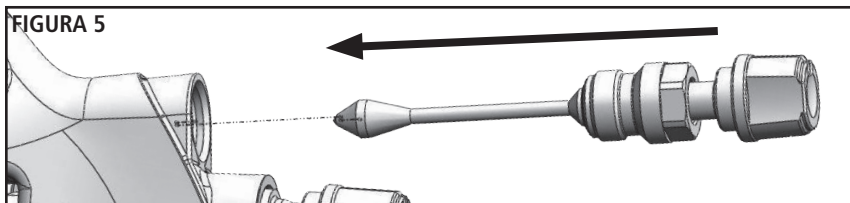
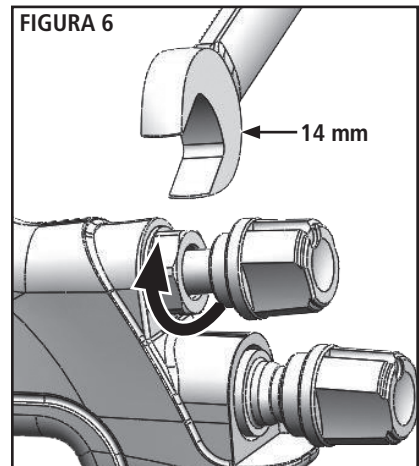
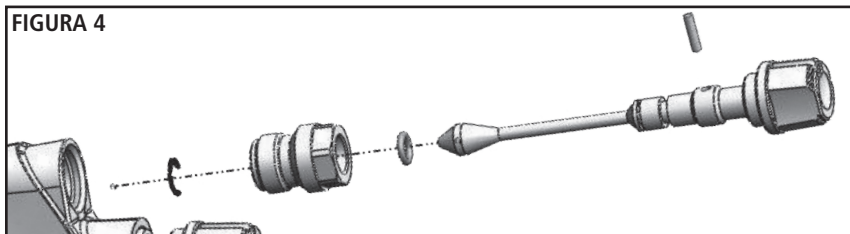
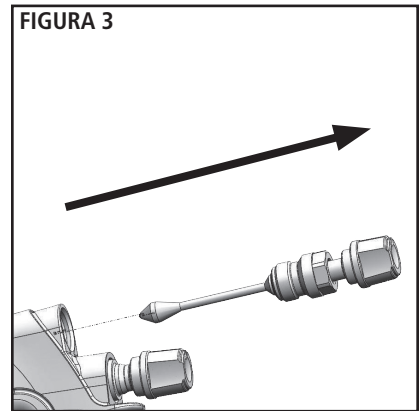
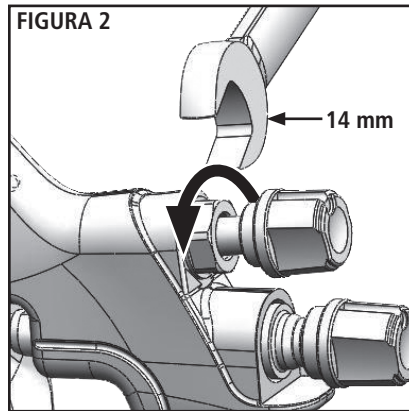
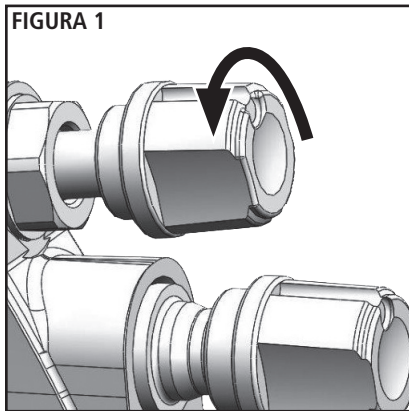

MANTENIMIENTO – REMOCIÓN E INSTALACIÓN DEL PUERTO LATERAL



LOCALIZACIÓN Y REPARACIÓN DE AVERÍAS

CONDICIÓN	CAUSA	CORRECCIÓN
Patrón recargado en la parte superior o inferior 	Orificios de la horquilla obstruidos. Obstrucción en la parte superior o inferior de la punta de fluido. Cubierta y/o asiento de la punta sucios.	Limpiar. Escariar con punta no metálica. Limpiar. Limpiar.
Patrón recargado hacia la derecha o hacia la izquierda 	Orificios obstruidos en el lado izquierdo o derecho de la horquilla. Suciedad en el lado izquierdo o derecho de la punta de fluido.	Limpiar. Escariar con punta no metálica. Limpiar.
Cómo corregir patrones recargados en la parte superior, inferior, hacia la derecha y hacia la izquierda: 1. Determinar si la obstrucción está en la cubierta de aire o en la punta de fluido. Hacer esto realizando una prueba de patrón de atomización. Luego, hacer girar la cubierta una media vuelta y atomizar otro patrón. Si se invierte el defecto, la obstrucción está en la cubierta de aire. Limpiar la cubierta de aire de la manera indicada anteriormente. 2. Si el defecto no se invierte, la obstrucción está en la punta de fluido. Revisar si hay una pequeña rebaba en el borde de la punta de fluido. Quitarla con papel de lija #600 mojado o seco. 3. Verificar si hay pintura seca dentro del orificio; eliminarla lavando con solvente.		
Patrón recargado en el centro 	Flujo de fluido demasiado alto para el aire de atomización. El flujo del material sobrepasa la capacidad de la cubierta de aire. Válvula de ajuste del dispersador fijada demasiado baja. Presión de atomización demasiado baja. Material demasiado espeso.	Equilibrar la presión del aire y del flujo de fluido. Aumentar el ancho del patrón de atomización con la válvula de ajuste del dispersador. Diluir o reducir el flujo de fluido. Ajustar. Aumentar la presión. Diluir hasta lograr la consistencia correcta.
Patrón de atomización dividido 	Presión demasiado alta del aire de atomización. Muy poco flujo de fluido. Ajuste de la válvula dispersora fijado demasiado alto.	Reducir la presión en el transformador o pistola. Aumentar el flujo de fluido (aumenta la velocidad de manipulación de la pistola). Ajustar.
Atomización entrecortada u ondulada 	*Punta de fluido/asiento flojo o dañado Nivel del material demasiado bajo. Recipiente demasiado inclinado. Obstrucción en el conducto de fluido. Tuerca de presión de la aguja de fluido seca o floja.	Apretarla o reemplazarla. Rellenar. Sostener más verticalmente. Purgar a contrapresión con solvente. Lubricar o apretar.
Imposibilidad de lograr atomización redondeada	Tornillo de ajuste del dispersador no asentado debidamente. Aro de retención de la cubierta de aire flojo.	Limpiar o reemplazar. Apretar.
No atomiza	No hay presión de aire en la pistola. El tornillo de ajuste de la aguja no está suficientemente abierto. El fluido es muy pesado para la alimentación por gravedad.	Revisar el suministro de aire y las líneas de aire, limpiar soplando los conductos de aire de la pistola. Abrir el tornillo de ajuste de la aguja de fluido. Diluir el material y/o usar una punta más grande.
Burbujas de pintura en la cubeta	La punta de fluido no está apretada.	Apretar la punta.

*El problema más común.

LOCALIZACIÓN Y REPARACIÓN DE AVERÍAS

CONDICIÓN	CAUSA	CORRECCIÓN
El fluido se filtra o gotea desde la tapa de la cubeta	Tapa de la cubeta floja. Roscas sucias en la cubeta o la tapa. Cubeta o tapa rajada.	Apretar la tapa. Limpiar. Reemplazar la cubeta y la tapa.
Patrón de atomización infraalimentado	Flujo inadecuado del material. Presión de aire de atomización baja.	Hacer retroceder el tornillo de ajuste de fluido hasta la primera rosca o usar una punta más grande. Aumentar la presión de aire y volver a equilibrar la pistola.
Sobreatomización excesiva	Demasiada presión de aire de atomización. Pistola muy alejada de la superficie de trabajo. Recorrido indebido (arqueado, movimiento muy rápido de la pistola).	Reducir la presión. Ajustar a la distancia debida. Mover a un ritmo moderado, paralelo a la superficie de trabajo.
Nebulización excesiva	Demasiado diluyente o diluyente de secado muy rápido. Demasiada atomización (presión de aire)	Volver a mezclar adecuadamente. Reducir la presión de aire.
Atomización seca	Presión de aire muy alta. Punta de la pistola muy alejada de la superficie de trabajo. Movimiento demasiado rápido de la pistola. Pistola desajustada.	Reducir la presión de aire. Ajustar a la distancia debida. Mover más despacio. Ajustar.
Filtración de fluido desde la tuerca de presión	Tuerca de presión floja. Empaquetadura gastada o seca.	Apretar, no trabar la aguja. Reemplazar o lubricar.
Filtración o goteo de fluido desde la parte delantera de la pistola	Tuerca de presión demasiado apretada. Empaquetadura seca. Punta o aguja de fluido desgastada o dañada. Materias foráneas en la punta. Muelle de la aguja de fluido roto. Aguja o punta de tamaño equivocado.	Ajustar. Lubricar. Reemplazar la punta y la aguja. Limpiar. Reemplazar. Reemplazar.
Fluido se filtra o gotea desde la parte inferior de la cubeta	Cubeta floja en la pistola. Empaque de la cubeta gastado o faltante debajo de la cubeta. Roscas sucias en la cubeta.	Apretar. Reemplazar el empaque de la cubeta. Limpiar.
Corrimiento de la pintura	Demasiado flujo de material. Material demasiado diluido. Pistola inclinada en ángulo o con movimiento muy lento.	Ajustar la pistola o reducir el flujo de fluido. Mezclar debidamente o aplicar capas livianas. Sostener la pistola en ángulo recto respecto de la superficie de trabajo y adaptarse a la técnica debida de atomizado.
Acabado fino, arenoso-rugoso que se seca antes de fluir	Pistola demasiado alejada de la superficie. Demasiada presión de aire. Se está usando diluyente inadecuado.	Revisar la distancia. Suele ser alrededor de 8". Reducir la presión de aire y revisar el patrón de atomización. Seguir las instrucciones de mezclado del fabricante de la pintura.
Acabado grueso, no uniforme, tipo "cáscara de naranja"	Pistola demasiado cerca de la superficie. Demasiado material fue atomizado con acabado espeso. Presión del aire demasiado baja. Se está usando diluyente inadecuado. Material no mezclado debidamente. Superficie áspera, grasosa, sucia.	Revisar la distancia. Suele ser alrededor de 8". Seguir las instrucciones de mezclado del fabricante de la pintura. Reducir la presión de aire o reducir el flujo de fluido. Seguir las instrucciones de mezclado del fabricante de la pintura. Seguir las instrucciones de mezclado del fabricante de la pintura. Limpiar y preparar debidamente.

ACCESORIOS

HAF-507-K12
Kit de 12 filtros de aire en línea Whirlwind™



Elimina agua, aceite y restos de la línea de aire.

192212 Kit de limpieza de pistola atomizadora profesional



Contiene seis herramientas de precisión diseñadas para limpiar eficazmente todas las pistolas atomizadoras de DeVilbiss, Binks, Finishline y de otras marcas.

6-429
Lubricante de pistola Gunners Mate de Binks (Veinte botellas de 2 oz)



Compatible con todos los materiales de pintura; no contiene silicio ni destilados de petróleo para contaminar la pintura. MSDS (Hoja de datos de seguridad de los materiales) disponible previa solicitud.

HAV-500 O HAV-501
Válvula de ajuste (HAV-501 MOSTRADA)



La HAV-500 no tiene manómetro. Se usa para controlar el uso de aire en la pistola.

Millennium 3000
Respirador para pulverizador de pintura con cartucho doble



Certificado por el NIOSH para protección respiratoria en atmósferas que no pongan en peligro inminente la vida.

Pequeño	Mediano	Grande
40-141	40-128	40-143

Acopladores de conexión rápida para pistolas de HVLP (aire)
 Tipo de flujo alto

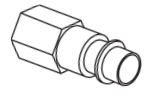

HC-4419 Vástago 1/4" NPT(F) Extremo de la pistola

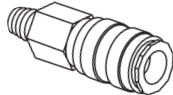

HC-4719 Acoplador 1/4" NPT(M) Extremo de la pistola

29-3100 Toallas Scrubs® para limpiarse las manos



Scrubs® son toallas de limpieza de manos prehumedecidas para pintores, operarios de talleres y mecánicos, para usarlas donde esté sin necesidad de agua.

54-6106
Cubeta del gravedad de 1 Qt. (aluminio)

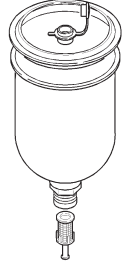

192219
Portapistola

Portapistola fabricado para sostener la pistola con cubetas de gravedad.



KGP-13-K5
Empaque de la cubeta











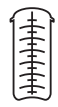
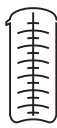
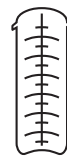



Empaque de la entrada de fluido necesario para usar con cubetas metálicas de gravedad.



54-6197
Tope de ajuste de la aguja



Accesorios DeKups® para cubetas de alimentación a gravedad

<p>DPC-60-K10 9oz Universal x10</p> 	<p>DPC-59-K10 24oz Universal x10</p> 	<p>DPC-61-K10 34oz Universal x10</p> 	<p>125 µm  DPC-42-K24 x24</p>	<p>200 µm  DPC-66-K24 x24</p>	<p> DPC-6-K10 x10</p>	
			<p>125 µm  DPC-65-K24 x24</p>	<p>200 µm  DPC-67-K24 x24</p>	<p> DPC-22-K24 x24</p>	
<p> DPC-607 x2</p>	<p> DPC-606 x2</p>	<p> DPC-608 x2</p>	<p> 9 FL 265 mL DPC-602 x32</p>	<p> 24 FL 710 mL DPC-601 x32</p>	<p> 34 FL 1000 mL DPC-600 x32</p>	<p> DPC-44</p>
<p>CASCOS</p>			<p>REVESTIMIENTOS</p>			<p> DPC-31</p>

POLÍTICA DE GARANTÍAS

Los productos Binks están cubiertos por la garantía limitada de materiales y mano de obra por un año de Carlisle Fluid Technologies. El uso de cualquier pieza o accesorio de una fuente que no sea Carlisle Fluid Technologies, anulará todas las garantías. Para obtener información específica sobre la garantía, favor ponerse en contacto con el local de Carlisle Fluid Technologies más cercano a usted entre los listados a continuación.

Carlisle Fluid Technologies se reserva el derecho de modificar las especificaciones del equipo sin previo aviso. DeVilbiss®, Ransburg®, MS®, BGK®, y Binks® son marcas registradas de Carlisle Fluid Technologies, Inc. ©2017 Carlisle Fluid Technologies, Inc. Reservados todos los derechos.



Binks es parte de Carlisle Fluid Technologies, un líder global en tecnologías de acabados innovadores. Para asistencia técnica o para localizar un distribuidor autorizado, póngase en contacto con uno de nuestros centros internacionales de ventas y apoyo al cliente listados.

EE.UU./Canadá

info@carlisleleft.com
Teléfono: 1-888-992-4657
Fax: 1-888-246-5732

México

ventas@carlisleleft.com.mx
Teléfono: 011 52 55 5321 2300
Fax: 011 52 55 5310 4790

Brasil

vendas@carlisleleft.com.br
Teléfono: +55 11 5641 2776
Fax: 55 11 5641 1256

Reino Unido

info@carlisleleft.eu
Teléfono: +44 (0)1202 571 111
Fax: +44 (0)1202 573 488

Francia

info@carlisleleft.eu
Teléfono: +33(0)475 75 27 00
Fax: +33(0)475 75 27 59

Alemania

info@carlisleleft.eu
Teléfono: +49 (0) 6074 403 1
Fax: +49 (0) 6074 403 281

China

mkt@carlisleleft.com.cn
Teléfono: +8621-3373 0108
Fax: +8621-3373 0308

Japón

overseas-sales@carlisleleft.co.jp
Teléfono: 081 45 785 6421
Fax: 081 45 785 6517

Australia

sales@carlisleleft.com.au
Teléfono: +61 (0) 2 8525 7555
Fax: +61 (0) 2 8525 7575

Para obtener la última información sobre nuestros productos, visite www.carlisleleft.com.



PISTOLETS PULVÉRISATEURS DE LA GAMME « TROPHY » DE BINKS

À ALIMENTATION PAR GRAVITÉ,
ASPIRATION TECHNOLOGIE
CONVENTIONNELLE, HVLP, ET LVMP
(2466-XXXX-XXXX)



CE  II 2 G X

Le pistolet pulvérisateur à alimentation par gravité de la gamme Trophy de Binks est le pistolet idéal pour les applications de pulvérisation avec alimentation par gravité. Il établit un nouveau standard en termes de durabilité, d'ergonomie et d'atomisation. Sa conception légère et ergonomique assure un contrôle et un confort inégalés. Il intègre la plus récente technologie avancée d'atomisation pour réaliser des finitions consistantes de très haute qualité pour une large gamme d'applications de revêtement industriel.

Les pistolets pulvérisateur à alimentation par gravité de la gamme Trophy de Binks sont proposés avec trois différentes technologies d'atomisation : HVLP, LVMP et conventionnelle.



SPÉCIFICATIONS

Les pistolets pulvérisateur de la gamme Trophy de Binks possèdent une grande efficacité de transfert conforme à la réglementation du "California South Coast Air Quality Management District" pour les pistolets pulvérisateurs à haut volume et basse pression.

Pression d'air maximale	140 lb/po ² / 9,6 bar (P-1)
Corps du pistolet	Aluminium anodisé
Circuit de fluide	Acier inoxydable
Dimension d'entrée du produit	3/8 po – 19 NPS / BSP(f)
Dimension d'entrée d'air	1/4 po NPS / BSP(m)
Poids du pistolet	13.8 oz. / 394 g (sans godet)
Pièces en contact avec le fluide	Stainless Steel & PTFE

IMPORTANT ! NE PAS DÉTRUIRE

Il est de la responsabilité du client de veiller à ce que tous les opérateurs et le personnel de service lisent et comprennent le présent manuel. Contactez votre représentant local Binks pour obtenir des exemplaires supplémentaires de ce manuel.

LIRE TOUTES LES INSTRUCTIONS AVANT D'UTILISER CE PRODUIT BINKS.

Dans la présente fiche technique, les mots **AVERTISSEMENT**, **ATTENTION** et **REMARQUE** servent à souligner des renseignements importants comme suit :

⚠ AVERTISSEMENT
Dangers ou pratiques dangereuses qui peuvent entraîner des blessures graves, la mort ou des dommages matériels considérables.

⚠ ATTENTION
Dangers ou pratiques dangereuses qui peuvent entraîner des blessures légères et des dommages matériels.

REMARQUE
Renseignements importants relatifs à l'installation, le fonctionnement ou l'entretien.

⚠ ATTENTION

Lisez les avertissements suivants avant d'utiliser cet équipement.



LIRE LE MANUEL

Avant d'utiliser le matériel de finition, il est impératif de lire et comprendre toutes les informations relatives à la sécurité, à l'utilisation et à l'entretien disponibles dans le mode d'emploi.



PORTER DES LUNETTES DE SÉCURITÉ

Ne pas porter de lunettes de sécurité à écrans latéraux peut entraîner des blessures oculaires sérieuses ou la cécité.



METTRE HORS TENSION, DÉPRESSURISER, DÉBRANCHER ET VERROUILLER TOUTES LES SOURCES D'ALIMENTATION DURANT L'ENTRETIEN

Ne pas mettre hors tension, déconnecter et verrouiller toutes les sources d'alimentation avant d'effectuer l'entretien de l'équipement peut causer des blessures graves ou la mort.



FORMATION DE L'OPÉRATEUR

Tout le personnel doit être formé avant d'utiliser le matériel de finition.



RISQUE LIÉ À UN UTILISATION ABUSIVE DE L'ÉQUIPEMENT

Une utilisation abusive de l'équipement peut provoquer une détérioration, un dysfonctionnement, ou un déclenchement soudain de l'équipement et entraîner des blessures graves.



GARDER EN PLACE LES PROTECTION DE L'ÉQUIPEMENT

Ne pas utiliser l'appareil si les sécurités ont été retirées.

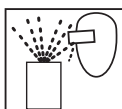

RISQUE DE PROJECTION

Vous pouvez être blessé par l'évacuation de liquides ou de gaz sous pression, ou par la projection de débris.



DANGER DE PINCEMENT

Les pièces mobiles peuvent écraser et couper. Les points de pincement sont en règle générale toutes les zones où il y a des pièces mobiles.



INSPECTER L'ÉQUIPEMENT QUOTIDIENNEMENT

Inspecter l'équipement quotidiennement pour rechercher les traces d'usure ou des pièces défectueuses. N'utilisez pas l'appareil si vous êtes incertain de son état.



NE JAMAIS MODIFIER L'ÉQUIPEMENT

Ne modifiez pas l'équipement, à moins d'obtenir l'autorisation écrite du fabricant.



TOUJOURS CONNAÎTRE L'EMPLACEMENT ET LE MODE D'EMPLOI DES DISPOSITIFS D'ARRÊT DE L'ÉQUIPEMENT POUR LES CAS D'URGENCE



PROCÉDURE DE DÉCOMPRESSION

Toujours suivre la procédure de décompression indiquée dans le manuel d'utilisation de l'équipement.



RISQUE LIÉ AU BRUIT

Vous pouvez être blessé par un bruit fort. Une protection auditive peut être nécessaire lors de l'utilisation de cet équipement.



CHARGE STATIQUE

Le fluide peut développer une charge statique qui doit être dissipée par le biais du raccordement à la terre de l'équipement, des objets à peindre et de tous les objets conducteurs d'électricité dans la zone d'application. Une mauvaise mise à la terre ou des étincelles peuvent créer une situation dangereuse et provoquer un incendie, une explosion, un choc électrique et d'autres blessures graves.



RISQUE D'INCENDIE ET D'EXPLOSION

Ne jamais utiliser de 1,1,1-trichloroéthane, de chlorure de méthylène, d'autres solvants hydrocarbures halogénés ou des fluides contenant de tels solvants dans un appareil avec des pièces en aluminium en contact avec le fluide. Une telle utilisation pourrait entraîner une grave réaction chimique, avec un risque d'explosion. Consultez vos fournisseurs de fluides pour vous assurer que les fluides utilisés sont compatibles avec les pièces en aluminium.



AVERTISSEMENT RELATIF À LA PROPOSITION 65

AVERTISSEMENT : Ce produit contient des produits chimiques reconnus par l'état de Californie pour causer le cancer et des malformations congénitales ou d'autres problèmes reproductifs.

IL INCOMBE À L'EMPLOYEUR DE FOURNIR CES RENSEIGNEMENTS À L'OPÉRATEUR DE L'APPAREIL.

POUR DE PLUS AMPLES INFORMATIONS CONCERNANT LES ÉQUIPEMENTS BINKS ET DEVILBISS, CONSULTEZ LE LIVRET DE SÉCURITÉ DES ÉQUIPEMENT (77-5300).

Description / objet de la Déclaration de produit:	Trophy
Ce produit a été conçu pour être utilisé avec :	Matériaux à base de solvant et d'eau
Approprié pour une utilisation dans des zones dangereuses :	Zones 1 / Zones 2
Niveau de protection :	II 2 G X
Notifiée de carrosserie et le rôle :	TRAC Global Ltd (0891) Introduction des Fiche technique
Cette déclaration de conformité / incorporation est établie sous la seule responsabilité du fabricant :	Carlisle Fluid Technologies, 320 Phillips Ave., Toledo, OH 43612

Déclaration de conformité EU



L'objet de la déclaration décrit ci-dessus est en conformité avec la législation d'harmonisation de l'Union :

Directive machines 2006/42/EC

Directive ATEX 2014/34/EU

en nous conformant aux documents statutaires et aux normes harmonisées suivants :

Norme EN ISO 12100 : Sécurité des machines - Principes généraux de conception

Norme BS, EN, 1953:2013 Équipements d'atomisation et de pulvérisation pour produits de revêtement - Exigences de sécurité

Norme EN 1127-1:2011 Atmosphères explosives - Prévention de l'explosion - Notions fondamentales

Norme EN 13463-1 : Appareils non électriques destinés à être utilisés en atmosphères explosibles - Méthodes et prescriptions de base

Offrir à tous les conditions d'utilisation sécuritaire / l'installation a déclaré dans les manuels des produits ont été respectées et également installé en conformité avec les codes locaux en vigueur de la pratique .

Signé pour et au nom de
Carlisle Fluid Technologies:

DJ Hasselschwert
11-Jul-16

(Vice-président : Global
Development Product)

Toledo, OH 43612

PISTOLET DE PULVÉRISATION À GRAVITÉ BINKS DE LA GAMME « TROPHY »

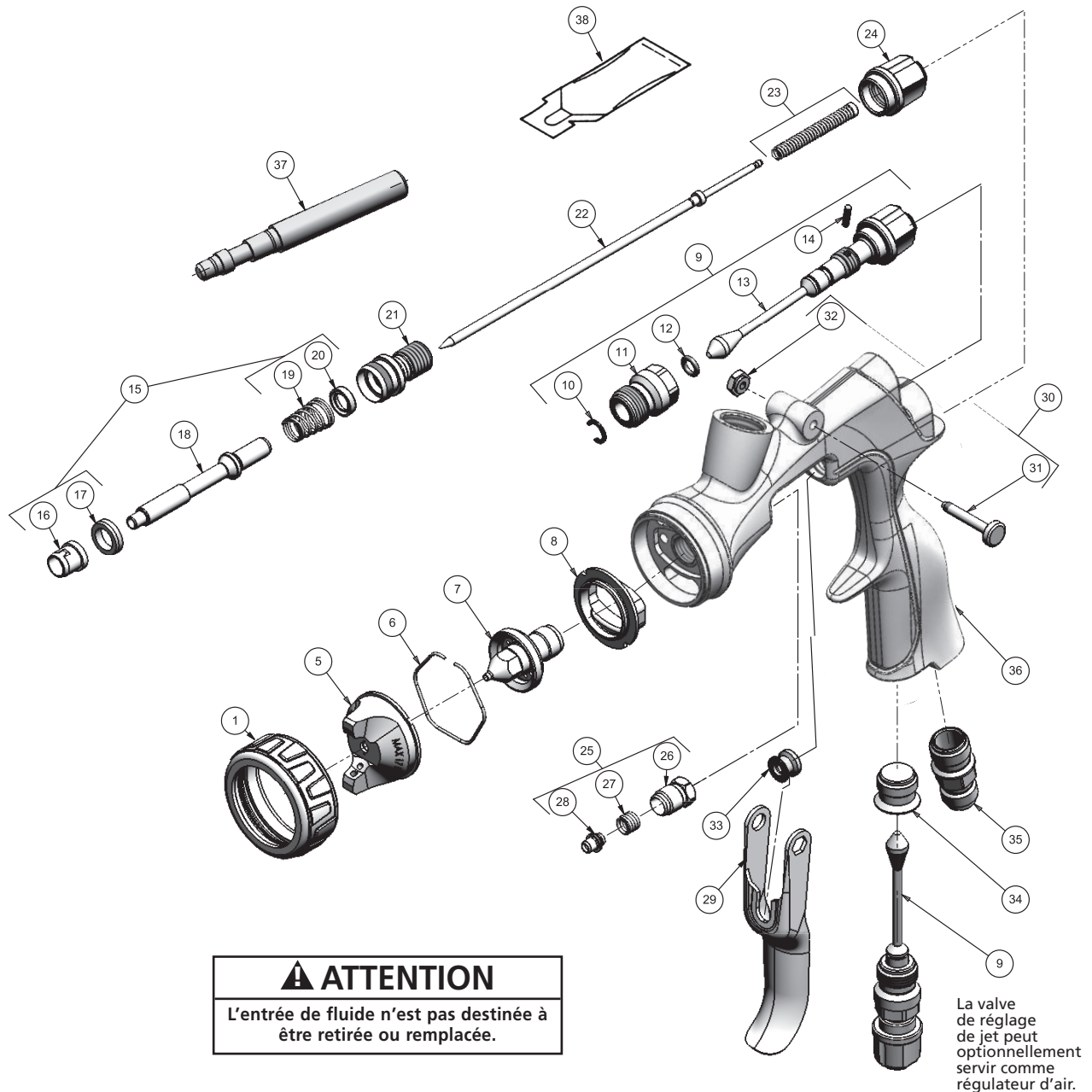

SYSTÈME DE NUMÉROTATION POUR LES PISTOLETS À GRAVITÉ COMPLETS DE LA GAMME « TROPHY » DE BINKS

2466 – XXXX – XXXX

PISTOLET À GRAVITÉ	↑	2466	↑	XXXX	↑	XXXX	↑	XXXX
TAILLES D'ORIFICE	↑	12 1,2 MM 14 1,4 MM 16 1,6 MM 18 1,8 MM	↑	TECHNOLOGIE DE PULVÉRISATION CN CONVENTIONNEL LV LVMP HV HVLP	↑	DÉSIGNATION DU GODET 0 AUCUN GODET G GODET À GRAVITÉ	↑	DÉSIGNATION DU CHAPEAU D'AIR Série 10 CONVENTIONNEL Série 20 LVMP Série 30 HVLP
						MATÉRIAU DE L'AIGUILLE S ACIER INOXYDABLE (DURCI)		

Voir les tableaux à la page 6 pour les ensembles complets de pistolets.

**TABLEAU 1 : LISTE DES PIÈCES DES PISTOLETS DE PULVÉRISATION À GRAVITÉ
BINKS DE LA GAMME « TROPHY »**

NUMÉRO D'ARTICLE	RÉFÉRENCE	DESCRIPTION	QTÉ	NUMÉRO D'ARTICLE	RÉFÉRENCE	DESCRIPTION	QTÉ
1	54-6120	ENSEMBLE BAGUE DE RETENUE DU CHAPEAU D'AIR	1	24	54-6111	MOLETTE DE RÉGLAGE DE L'AIGUILLE	1
5	SEE CHARTS ON PAGE 7	CHAPEAU D'AIR	1	25	54-6130-K	KIT DE PRESSE-ÉTOUPE D'AIGUILLE (STANDARD)	1
6	JGA-156-K10	CLIP DE RETENUE (KIT DE 10)	1	26	-----	■ ÉCROU DE PRESSE-ÉTOUPE	1
7	SEE CHARTS BELOW	BUSE DE FLUIDE	1	27	-----	■ RESSORT DE PRESSE-ÉTOUPE	1
8	54-6102-K3	DÉFLECTEUR/SÉPARATEUR (KIT DE 3)	1	28	-----	□ ■ ▼ PRESSE-ÉTOUPE D'AIGUILLE (STANDARD)	1
9	54-6122	ENSEMBLE VALVE DE RÉGLAGE DE JET	1	29	54-4360	GÂCHETTE	1
10	-----	+ △ CLIP DE RETENUE	1	30	54-6132-K	KIT VIS ET ÉCROU DE LA GÂCHETTE	1
11	-----	+ BAGUE DE CORPS	1	31	-----	○ VIS DE LA GÂCHETTE	1
12	-----	+ △ JOINT TORIQUE	1	32	-----	○ ÉCROU DE LA GÂCHETTE	1
13	-----	+ MOLETTE DE RÉGLAGE DE VALVE DE RÉGLAGE DE JET	1	33	54-3513	EMBOUT DE TIGE	1
14	-----	+ △ GOUPILLE	1	34	SN-11	RACCORD	1
15	54-6131-K	□ KIT DE RÉGLAGE DU DÉBIT D'AIR	1	35	54-6112	RACCORD – ENTRÉE D'AIR	1
16	-----	• JOINT AVANT – SOUPAPE D'AIR	1	36	-----	CORPS DE PISTOLET AVEC ENTRÉE DE FLUIDE	1
17	-----	• JOINT AVANT DE LA SOUPAPE D'AIR	1	37	-----	OUTIL – INSERTION DE JOINT	1
18	54-6109	□ TIGE DE LA SOUPAPE D'AIR	1	38	-----	LUBRIFIANT GUNNER'S MATE (SACHET DE 3 CC)	1
19	-----	• RESSORT DE LA SOUPAPE D'AIR	1				
20	-----	• JOINT ARRIÈRE – SOUPAPE D'AIR	1				
21	SN-66	CORPS DE VALVE	1				
22	47-6825	AIGUILLE – ACIER INOXYDABLE (STD).	1				
23	-----	□ ENSEMBLE RESSORT ET TAMPON D'AIGUILLE	1				
	54-6133-K3	ENSEMBLE RESSORT ET TAMPON D'AIGUILLE (STANDARD) (KIT DE 3)	1				

+	PIÈCES COMPRISE DANS 54-6122	○	PIÈCES COMPRISE DANS 54-6132-K
■	PIÈCES COMPRISE DANS 54-6130-K	△	KIT DE RÉPARATION DE LA VALVE DE RÉGLAGE DE JET GTI-428-K5
▼	ÉGALEMENT DISPONIBLE EN KIT de 3 SN-2-K3	□	PIÈCES COMPRISE DANS 54-6135
•	PIÈCES COMPRISE DANS 54-6131-K		

**TABLEAU 2:
BUSES EN ACIER INOXYDABLE (DURCI) –
STD.**

TAILLE DE L'ORIFICE DE LA BUSE EN ACIER INOXYDABLE		NUMÉRO DE RÉFÉRENCE DE LA BUSE
.039 po	1,0 mm	45-11050-10
.047 po	1,2 mm	45-11050-12
.055 po	1,4 mm	45-11050-14
.063 po	1,6 mm	45-11050-16
.071 po	1,8 mm	45-11050-18

**TABLEAU 3:
KITS D'ESSAI DE
CHAPEAU D'AIR – EN
OPTION**

CONVENTIONNEL	
54-6141-K	KIT 12-C
LVMP	
54-6147-K	KIT 23-L
HVLP	
54-6152-K	KIT 32-H – HVLP

GUIDE DE SÉLECTION DES BUSES ET AIGUILLES DES PISTOLETS DE LA GAMME "TROPHY" DE BINKS À ALIMENTATION PAR GRAVITÉ

TABLEAU 4 : CONFIGURATIONS DE PISTOLET CONVENTIONNEL

TYPE DE LIQUIDE À PULVÉRISER	NUMÉRO DE RÉFÉRENCE DE L'ENSEMBLE PISTOLET COMPLET	BUSE DE FLUIDE EY CHAPEAU D'AIR
MINCE 5-25 CENTIPOISE Coupe 2 de Zahn 15-19 s Wash primers, teintures, lasures, solvants, eau, encres, peintures d'impression, laques, lubrifiants, chromates de zinc, acryliques	2466-14CN-12SG	1,4 mm (.055 po) X 12C
	2466-16CN-12SG	1,6 mm (.063 po) X 12C
MÉDIUM 25-70 CENTIPOISE Coupe 2 de Zahn 20-30 s émail synthétique, vernis, laque, enduits, apprêts, époxy, uréthanes, lubrifiants, émulsions de cires, émaux	2466-16CN-12SG	1,6 mm (.063 po) X 12C
	2466-18CN-12SG	1,8 mm (.070 po) X 12C

TABLEAU 5 : CONFIGURATIONS DE PISTOLET LVMP

TYPE DE LIQUIDE À PULVÉRISER	NUMÉRO DE RÉFÉRENCE DE L'ENSEMBLE PISTOLET COMPLET	BUSE DE FLUIDE EY CHAPEAU D'AIR
MINCE 5-25 CENTIPOISE Coupe 2 de Zahn 15-19 s Wash primers, teintures, lasures, solvants, eau, encres, peintures d'impression, laques, lubrifiants, chromates de zinc, acryliques	2466-12LV-23SG	1,2 mm (.067 po) X 23L
	2466-14LV-23SG	1,4 mm (.055 po) X 23L
MÉDIUM 25-70 CENTIPOISE Coupe 2 de Zahn 20-30 s émail synthétique, vernis, laque, enduits, apprêts, époxy, uréthanes, lubrifiants, émulsions de cires, émaux	2466-14LV-23SG	1,4 mm (.055 po) X 23L
	2466-18LV-23SG	1,8 mm (.070 po) X 23L

TABLEAU 6 : CONFIGURATIONS DE PISTOLET HVLP

TYPE DE LIQUIDE À PULVÉRISER	NUMÉRO DE RÉFÉRENCE DE L'ENSEMBLE PISTOLET COMPLET	BUSE DE FLUIDE EY CHAPEAU D'AIR
MINCE 5-25 CENTIPOISE Coupe 2 de Zahn 15-19 s Wash primers, teintures, lasures, solvants, eau, encres, peintures d'impression, laques, lubrifiants, chromates de zinc, acryliques	2466-12HV-32SG	1,2 mm (.047 po) X 32H
	2466-14HV-32SG	1,4 mm (.055 po) X 32H
MÉDIUM 25-70 CENTIPOISE Coupe 2 de Zahn 20-30 s émail synthétique, vernis, laque, enduits, apprêts, époxy, uréthanes, lubrifiants, émulsions de cires, émaux	2466-14HV-32SG	1,4 mm (.055 po) X 32H
	2466-18HV-32SG	1,8 mm (.070 po) X 32H

TABLEAUX DE SÉLECTION DES BUSES ET DES CHAPEAUX D'AIR DES PISTOLETS DE PULVÉRISATION À GRAVITÉ DE LA GAMME "TROPHY" DE BINKS

TABLEAU 7 : TABLEAU DE SÉLECTION DES BUSES ET DES CHAPEAUX D'AIR CONVENTIONNELS

Chapeau d'air	N° de réf. du chapeau d'air	Plage répartition de pulvérisation	PI ³ /MIN À 30 LB/PO ²	PI ³ /MIN À 50 LB/PO ²	PI ³ /MIN À 70 LB/PO ²	Buse de fluide	Revêtements types
12-C	46-6501	4 – 12 po	8,3	12,1	14,2	Série 45-11050, 1,2 mm – 1,8 mm	Laques, émaux, couches de finition, adhésifs à faible viscosité

TABLEAU 8 : TABLEAU DE SÉLECTION DES BUSES ET DES CHAPEAUX D'AIR À BAS VOLUME ET PRESSION MOYENNE - LVMP

Chapeau d'air	N° de réf. du chapeau d'air	Plage répartition de pulvérisation	PI ³ /MIN @ 30 lb/po ² entrée du pistolet (dynamique)	Buse de fluide	Revêtements types
23-L	46-6511	4 – 12 po	10,6	Série 45-11050, 1,2 mm – 1,8 mm	Laques, émaux, couches de finition, adhésifs à faible viscosité
24-L	46-6512	2 – 6 po	14,3	Série 45-11050, 1,0 à 1,8 mm	Petites applications de motif de taches, émaux, acryliques

TABLEAU 9 : TABLEAU DE SÉLECTION DES BUSES ET DES CHAPEAUX D'AIR À HAUT VOLUME ET PRESSION MOYENNE - HVLP

Chapeau d'air	N° de réf. du chapeau d'air	Plage répartition de pulvérisation	pi ³ /min @ 10 lb/po ² pression du chapeau (dynamique)	Entrée de pistolet lb/po ² @ 10 lb/po ² au chapeau d'air (dynamique)	Buse de fluide	Revêtements types
32-H	46-6518	8 – 14 po	15,5	26	Série 45-11050, 1,2 mm – 1,8 mm	Laques, émaux, multi-couleurs, Multi-spécification, revêtement anti-adhésif, Latex pré-coupé

TABLEAU 10 : TABLEAU DE SÉLECTION DES BUSES ET DES CHAPEAUX D'AIR POUR JETS RONDS

Chapeau d'air	N° de réf. du chapeau d'air	Plage répartition de pulvérisation	PI ³ /MIN À 30 LB/PO ²	PI ³ /MIN À 50 LB/PO ²	PI ³ /MIN À 70 LB/PO ²	Buse de fluide	Revêtements types
16	46-6505	2 – 4 po	5,6	7,8	10,5	Série 45-11050, 1,2 mm – 1,8 mm	Laques, émaux

TYPES D'INSTALLATION

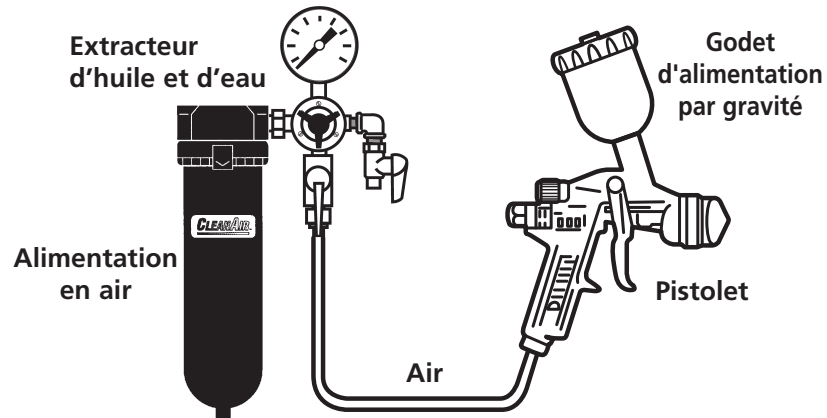

La pression d'air pour l'atomisation est réglée sur l'extracteur. Le débit du fluide dépend de la position de la valve de réglage de jet sur le pistolet, de la viscosité de la peinture et de la pression de l'air.

BRANCHEMENT POUR ALIMENTATION PAR GRAVITÉ

Sur les pistolets gravitaires la godet se trouve au-dessus de l'arme. La force de gravité pousse le fluide dans le pistolet.

Avantages: cette méthode offre des changements de couleur rapides et de proximité pour les petits travaux ou de retouche d'applications. Pistolets à gravité sont en mesure d'utiliser la totalité des déchets revêtement de réduction.

PRESSION D'AIR

La pression de pulvérisation doit être correctement réglée pour permettre une chute de pression d'air entre le régulateur et le pistolet.

AVEC 60 LB/PO² APPLIQUÉE À L'ADMISSION D'AIR



5/16 po

RECOMMANDÉ

48 Lb/po² à l'entrée du pistolet
25 pieds d'un flexible avec D.I. 5/16 po entraîne une chute de pression de 12 lb/po² entre l'alimentation en air et le pistolet. Pour cette raison, Binks recommande l'utilisation du tuyau 5/16 po.

*Vue en coupe transversale illustrant une comparaison des diamètres intérieurs du flexible (taille réelle).
pression réglée de 60 lb*



1/4 po

NON RECOMMANDÉ

Seulement 34 Lb/po² à l'entrée du pistolet

25 pieds d'un flexible avec D.I. 1/4 po entraîne une chute de pression de 26 lb/po² entre l'alimentation en air et le pistolet.

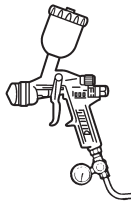

Un extracteur d'huile et d'eau est important.

Réaliser une pulvérisation de finition de grande qualité sans l'utilisation d'un bon extracteur d'huile et d'eau est pratiquement impossible.

Le régulateur/extracteur effectue une double fonction. Il élimine la formation de cloques et tacheture en gardant l'air exempt d'huile et d'eau, et il assure un contrôle précis de la pression de l'air depuis le pistolet.

Utilisez les régulateurs et les extracteurs d'huile et d'eau de DeVilbiss. Contacter votre distributeur local pour les modèles.

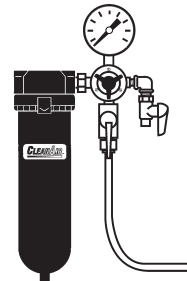

INSTRUCTIONS D'INSTALLATION

Pour une efficacité de transfert maximale, ne pas utiliser plus de pression que nécessaire pour pulvériser le produit à appliquer.

REMARQUE

Lors de l'utilisation du HVLP, ne pas dépasser les pressions d'admission indiquées à la page 7.

1. Raccorder le pistolet à une alimentation en air propre, sèche et exempte d'huile au moyen d'un flexible conducteur d'au moins 5/16 po de D.I.

REMARQUE

Selon la longueur du flexible, un flexible de diamètre intérieur plus gros pourrait être nécessaire. Monter un manomètre sur la poignée du pistolet. Voir la page 7 pour les pressions de fonctionnement. Ne pas utiliser plus de pression que nécessaire pour pulvériser le produit à appliquer. Une pression excessive accroît les retombées de pistolage et réduit l'efficacité du transfert de produit.

REMARQUE

Si des raccords rapides sont nécessaires, utiliser uniquement des raccords haut débit homologués pour l'usage HVLP. Le débit d'air offert par d'autres types risque d'être insuffisant pour permettre au pistolet de fonctionner correctement.

REMARQUE

Si une soupape de réglage d'air est utilisée à l'entrée du pistolet, utiliser une soupape de réglage HAV-501.

REMARQUE

Avant d'utiliser le pistolet, le rincer avec du solvant pour s'assurer que les canalisations soient propres.

FONCTIONNEMENT

MODÈLES À GRAVITÉ

1. Mixer le produit selon les instructions du fabricant et le filtrer.
2. Le niveau du produit doit s'arrêter à 3/4 po au moins du haut du godet. NE PAS REMPLIR EXCESSIVEMENT.
3. Fixer le godet sur le couvercle.
4. Tourner la molette de réglage de produit (24) dans le sens horaire pour immobiliser l'aiguille.
5. Tourner la molette de la valve de réglage de jet (9) dans le sens antihoraire pour l'ouvrir complètement.
6. Régler la pression d'entrée d'air au besoin.
7. Tourner la molette de réglage de produit dans le sens antihoraire jusqu'à l'apparition du premier filet.
8. Faire un essai de pulvérisation. Si la finition est trop sèche, réduire la pression d'entrée pour réduire le flux d'air.

9. Si la finition est trop humide, tourner la molette de réglage de produit (24) dans le sens horaire pour réduire le débit. Si la pulvérisation est trop grossière, augmenter la pression d'entrée d'air. Si elle est trop fine, réduire la pression d'entrée.
10. La taille du jet peut être réduite en tournant la molette de la valve (9) dans le sens horaire.
11. Maintenir le pistolet perpendiculaire à la surface de travail. L'application risque de ne pas être uniforme si le pistolet est incliné vers le haut ou le bas.
12. La distance de pulvérisation préconisée est de 8 pouces.
13. Commencer la pulvérisation sur les côtés. Empiéter au moins de 75% sur la pulvérisation précédente. Déplacer le pistolet à vitesse constante.
14. Toujours couper l'arrivée d'air et évacuer la pression quand le pistolet est inutilisé.

ENTRETIEN PRÉVENTIF ET NETTOYAGE

Pour nettoyer le chapeau d'air et la buse, brosser l'extérieur avec une brosse dure. Si les trous du chapeau ont besoin d'être nettoyés, utiliser une paille ou un cure-dents de préférence. Si du fil métallique ou un instrument dur est utilisé, veiller à ne pas endommager les orifices ce qui aurait pour effet de déformer le jet.

Pour nettoyer les conduits de produit, vider l'excédent de produit du godet puis rincer avec la solution nettoyante du pistolet. Essuyer l'extérieur du pistolet avec un chiffon humide. Ne jamais plonger le produit entièrement dans du solvant ou du nettoyant qui risquent de détériorer les lubrifiants et réduire la durée de vie du pistolet.

REMARQUE

S'il faut remplacer la buse (7) ou l'aiguille (22), les deux doivent être remplacées en même temps. L'utilisation de pièces usées peut causer des fuites de produit. Voir page 4. Remplacer également le presse-étoupe de l'aiguille à cette occasion. Serrer la buse avec un couple de 230-240 po-lb. Ne pas serrer excessivement.

⚠ ATTENTION

Pour ne pas endommager la buse (7) ou l'aiguille (22), toujours 1) actionner et maintenir la gâchette pendant le serrage ou le desserrage de la buse, ou 2) enlever la molette de réglage de produit (24) pour réduire la pression du ressort contre la bague de l'aiguille.

GODET À GRAVITÉ Vider l'excès de produit et nettoyer le godet. S'assurer que l'évent du couvercle n'est pas obstrué.

PROCÉDURES DE MONTAGE ET DE DÉMONTAGE

MONTAGE ET DÉMONTAGE DE L'AIGUILLE ET DE LA VALVE

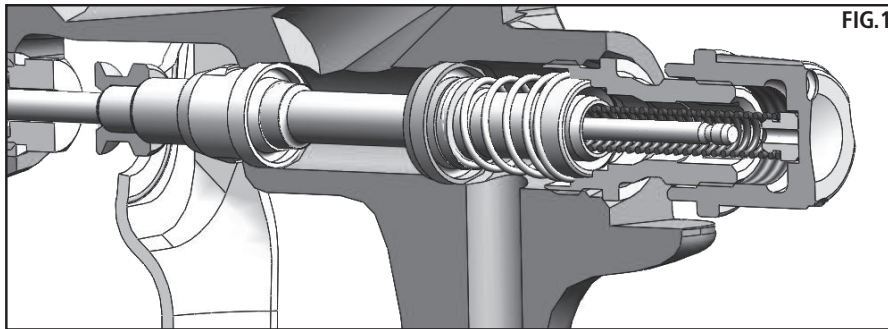

DÉMONTAGE

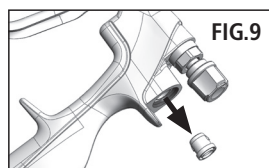
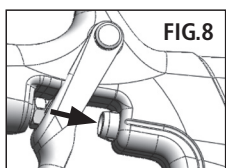
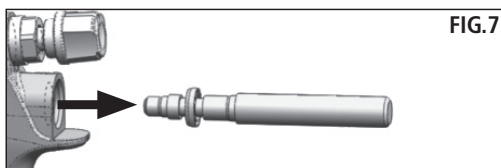
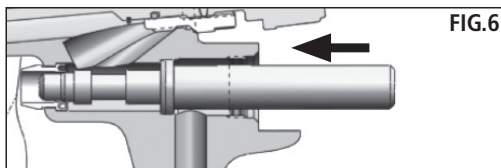
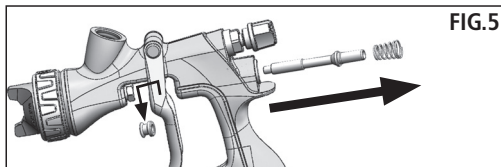
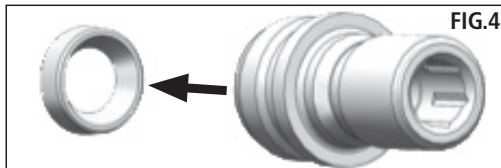
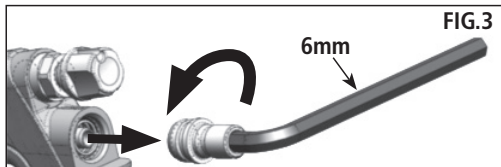
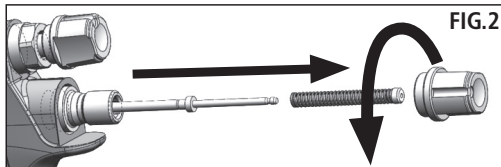

MONTAGE

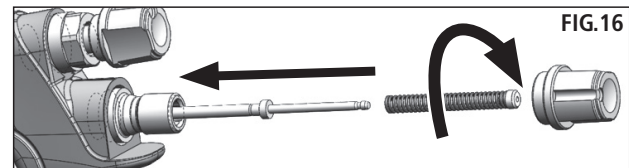
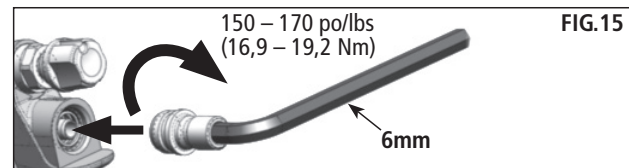
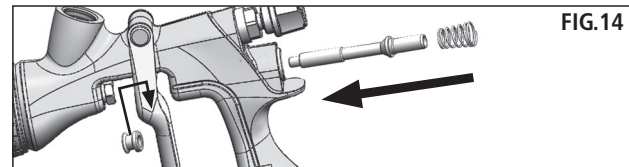
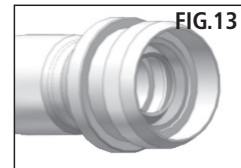
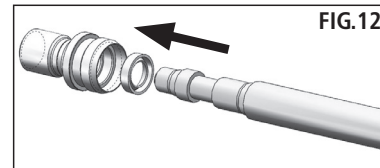
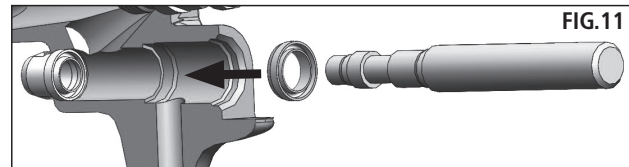
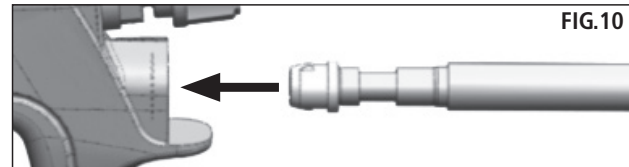

ENTRETIEN – MONTAGE ET DE DÉMONTAGE DE LA BUSE ET DU DÉFLECTEUR

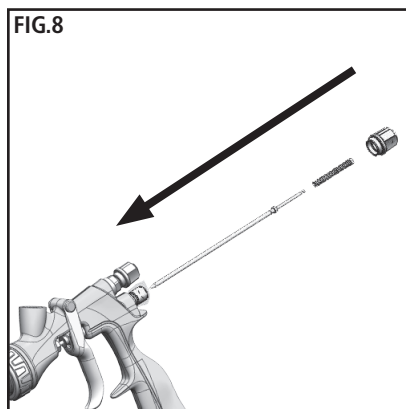
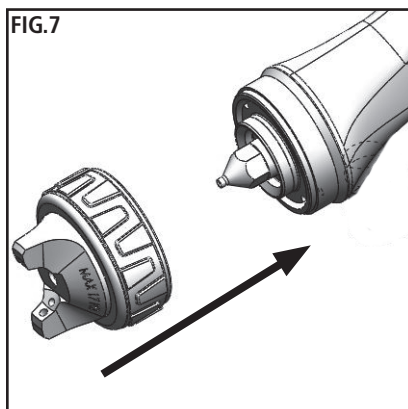
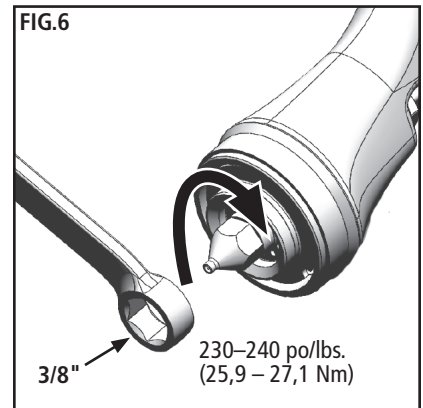
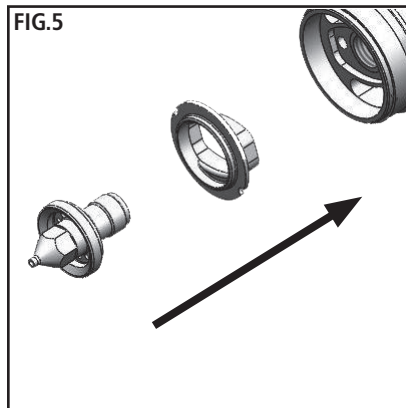
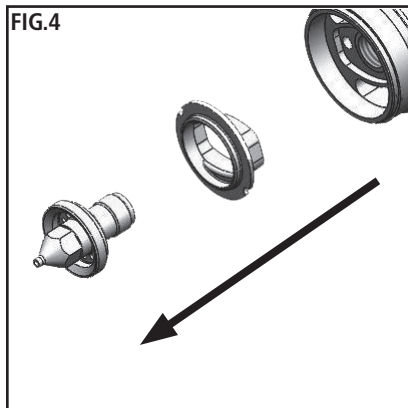
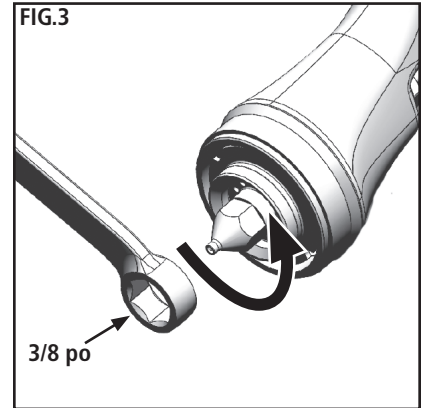
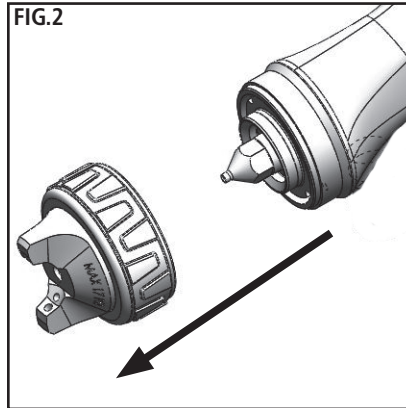
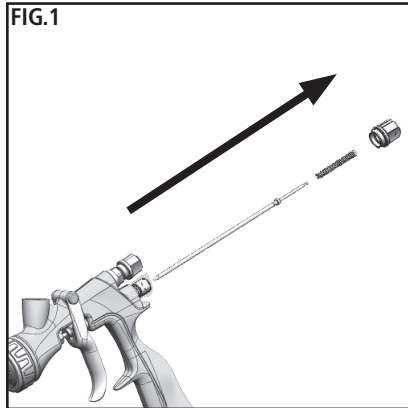

INSTALLATION DU DOIGT D'INDEXAGE DU CHAPEAU D'AIR (EN OPTION - FONCTION D'INDEXATION À 90°)

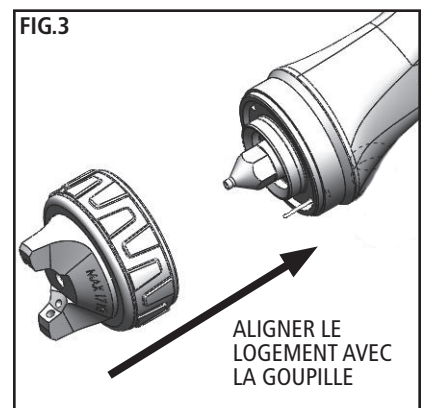
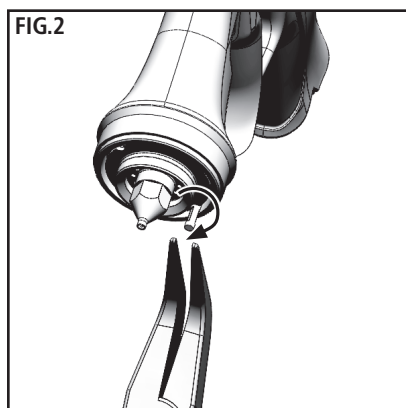
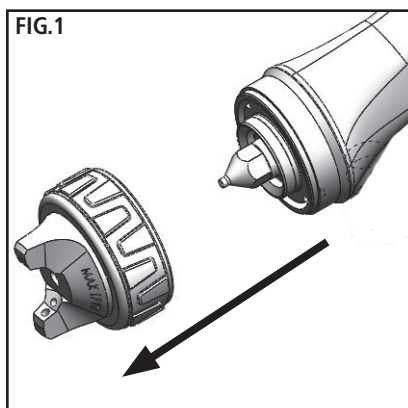



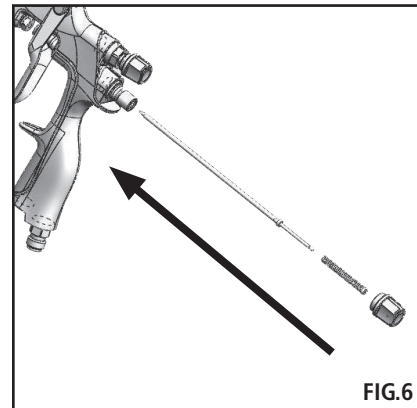
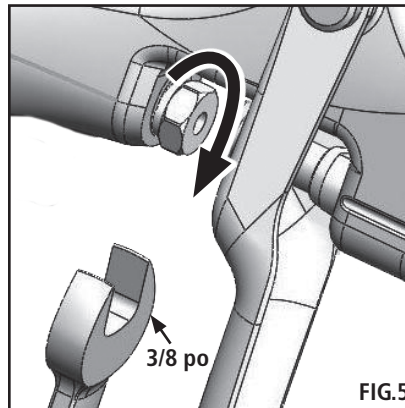
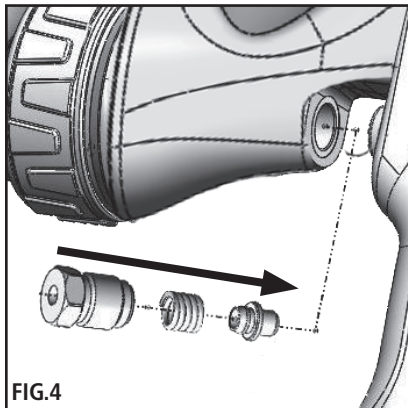
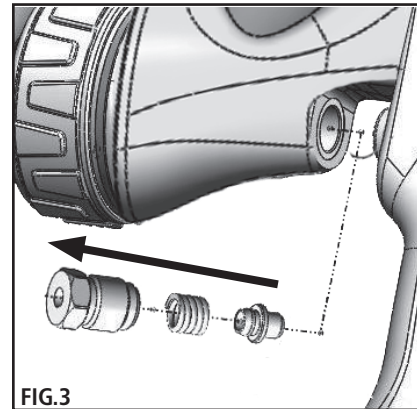
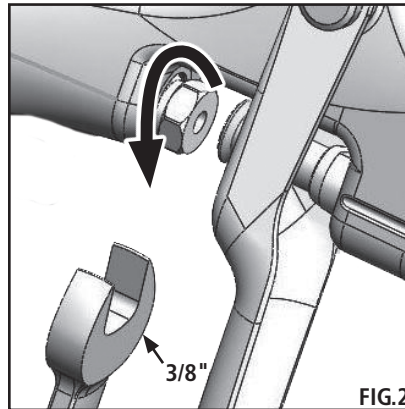
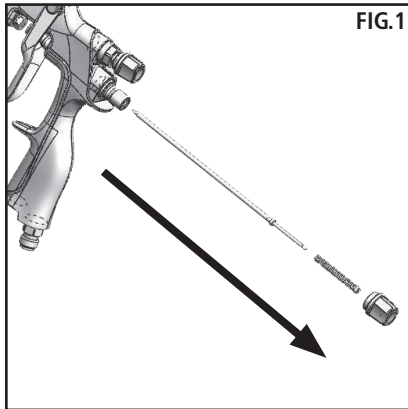

ENTRETIEN – MONTAGE ET DÉMONTAGE DU PRESSE-ÉTOUPE DE L'AIGUILLE

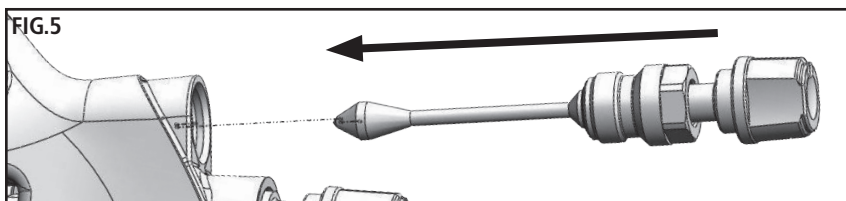
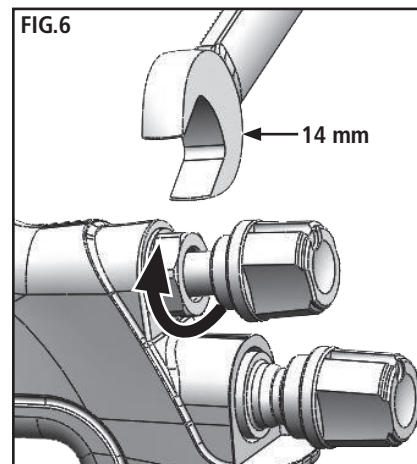
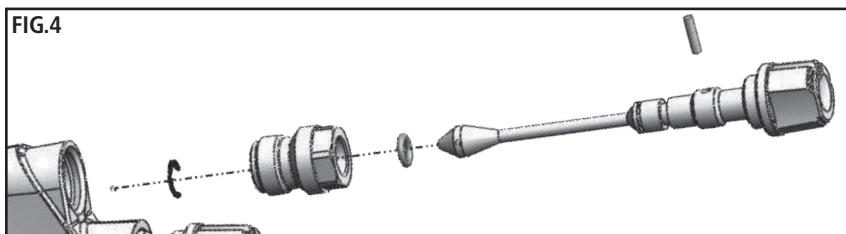
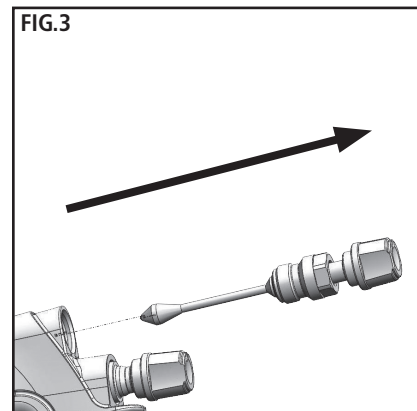
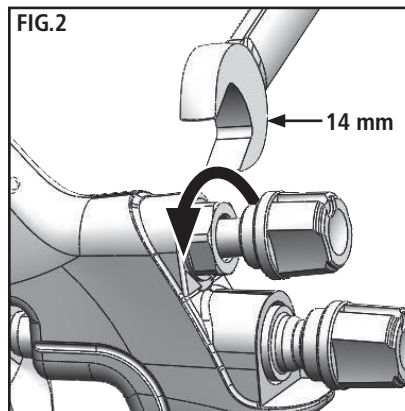
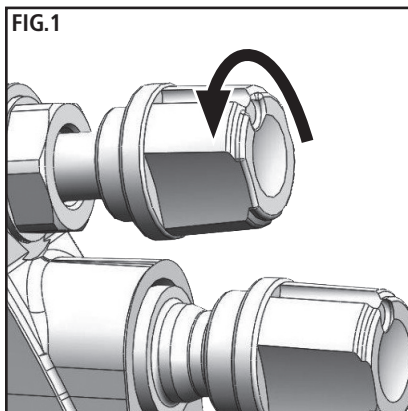

ENTRETIEN – MONTAGE ET DÉMONTAGE DE LA VALVE DE RÉGLAGE DE JET



DÉPANNAGE

CONDITION	CAUSE	CORRECTION
Surépaisseur en haut et en bas 	Trous évasés bouchés. Obstruction en haut ou en bas de la buse. Chapeau et/ou siège de buse encrassé.	Nettoyer. Aléser avec une pointe non-métallique. Nettoyer. Nettoyer.
Surépaisseur à droite ou à gauche 	Trous évasés gauches ou droits bouchés. Côté gauche ou droit de la buse encrassé.	Nettoyer. Aléser avec une pointe non-métallique. Nettoyer.
	Solutions pour remédier à la surépaisseur de produit en haut, en bas, à droite et à gauche : 1. Déterminer si l'obstruction se situe sur le chapeau d'air ou la buse. Pour ce faire, effectuer un essai de pulvérisation. Tourner ensuite le chapeau d'un demi-tour et effectuer une nouvelle pulvérisation. Si le défaut est inversé, l'obstruction se situe sur le chapeau d'air. Nettoyer le chapeau d'air comme expliqué précédemment. 2. Si le défaut n'est pas inversé, le problème provient de la buse. Vérifier si de la peinture sèche s'est déposée sur le bord de la buse. Enlever avec du papier de verre humide ou sec #600. 3. Vérifier si de la peinture sèche est déposée dans l'orifice central du chapeau et l'éliminer au besoin avec du solvant.	
Surépaisseur centrale 	Débit de fluide trop élevé pour l'air de pulvérisation. Le débit du produit dépasse la capacité du chapeau d'air. Valve de réglage de jet trop fermée. Pression de pulvérisation trop faible. Produit trop épais.	Régler la pression d'air et le débit du produit. Augmenter la largeur de pulvérisation avec la valve de réglage de jet. Réduire le débit du produit. Régler. Augmenter la pression. Diluer pour obtenir une consistance correcte.
Creux au centre de l'application 	Pression d'air trop élevée. Débit de produit trop faible. Molette de réglage de produit trop serrée.	Réduire au niveau du régulateur ou de la poignée du pistolet. Augmenter le débit du produit (augmente la vitesse d'utilisation du pistolet). Régler.
Projection irrégulière ou saccadée 	* Buse ou siège desserré ou endommagé. Niveau de produit insuffisant. Godet trop incliné. Obstruction dans le conduit de produit. Écrou de presse-étoupe d'aiguille desserré ou sec.	Serrer ou remplacer. Rajouter du produit. Redresser le pistolet. Rincer avec du solvant. Lubrifier ou serrer.
Impossible d'obtenir une pulvérisation ronde	La vis de réglage du jet n'est pas correctement mise en place. La bague de retenue du chapeau d'air est desserrée.	Nettoyer ou remplacer. Serrer.
Aucune pulvérisation	Aucune pression d'air dans le pistolet. La vis de réglage de l'aiguille de produit est trop fermée. Le produit est trop épais pour une alimentation par gravité.	Vérifier l'alimentation en air et les tuyaux d'air, souffler le circuit d'air du pistolet. Ouvrir la vis de réglage de l'aiguille de produit. Diluer le produit et/ou changer par un plus grand orifice central.
Bulles de peinture dans le godet	La buse n'est pas serrée.	Serrer la buse.
Le produit fuit ou s'égoutte par le couvercle du godet	Couvercle de godet mal fermé. filets du couvercle encrassés. Godet ou couvercle fissuré.	Serrer le couvercle. Nettoyer. Remplacer le godet et le couvercle.

* Le problème le plus courant.

DÉPANNAGE

CONDITION	CAUSE	CORRECTION
Projection faible	Mauvais débit de produit. Pression d'air de pulvérisation trop basse.	Desserrer la molette de réglage de produit ou remplacer la buse par une buse plus grande. Augmenter la pression d'air et équilibrer le pistolet.
Retombées de pistolage excessives	Pression d'air trop élevée. Pistolet trop loin de la surface de travail. Mauvaise application (inclinaison, mouvement trop rapide du pistolet).	Réduire la pression. Ajuster la distance du pistolet. Travailler à un rythme modéré, parallèlement à la surface de travail.
Dissipation excessive	Trop de diluant ou le diluant sèche trop rapidement. Pression d'air trop élevée (pression de pulvérisation).	Re-mélanger correctement. Réduire la pression d'air.
Pulvérisation sèche	Pression d'air trop élevée. Pistolet trop loin de la surface de travail. Mouvement du pistolet trop rapide. Pistolet mal réglé.	Réduire la pression d'air. Ajuster la distance du pistolet. Ralentir. Régler.
Fuite de produit par l'écrou de presse-étoupe	Écrou de presse-étoupe desserré. Presse-étoupe usé ou sec.	Serrer sans affecter l'aiguille. Remplacer ou lubrifier.
Fuite de produit par l'avant du pistolet	Écrou de presse-étoupe trop serré. Presse-étoupe sec. Buse ou aiguille usée ou endommagée. Corps étranger dans la buse. Ressort de l'aiguille endommagé. Aiguille ou buse de dimension incorrecte.	Régler. Lubrifier. Remplacer la buse et l'aiguille. Nettoyer. Remplacer. Remplacer.
Fuite de produit par le fond du godet	Godet desserré. Joint de godet usé ou manquant. Filets du godet encrassés.	Serrer. Remplacer le joint du godet. Nettoyer.
Coulures et festons	Débit de produit excessif. Produit trop dilué. Pistolet incliné ou mouvement d'application trop lent.	Régler le pistolet ou réduire le débit du produit. Mélanger correctement ou appliquer en couches minces. Tenir le pistolet à l'angle correct et adopter une technique de pistolage correcte.
Finition mince, grossière et sableuse séchant avant l'application	Pistolet trop loin de la surface de travail. Pression d'air trop élevée. Mauvais diluant utilisé.	Vérifier la distance. Elle est normalement d'environ 8 po. Réduire la pression d'air et vérifier la projection. Suivre les instructions de préparation du fabricant de peinture.
Finition épaisse en « peau d'orange »	Pistolet trop proche de la surface. Trop de produit pulvérisé grossièrement. Pression d'air trop faible. Mauvais diluant utilisé. Produit incorrectement préparé. Surface rugueuse, grasse, encrassée.	Vérifier la distance. Elle est normalement d'environ 8 po. Suivre les instructions de préparation du fabricant de peinture. Augmenter la pression d'air ou réduire le débit du produit. Suivre les instructions de préparation du fabricant de peinture. Suivre les instructions de préparation du fabricant de peinture. Nettoyer et préparer correctement.

ACCESSOIRES

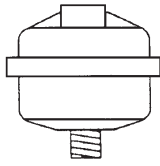
HAF-507-K12
Kit de filtrage d'air
en ligne Whirlwind™
kit de 12

Nettoie l'air de toute trace d'eau, d'huile et de débris.

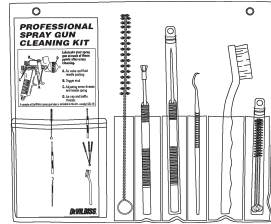
192212
Kit de nettoyage de pistolet pulvérisateur
professionnel

Contient six outils de précision conçus pour nettoyer efficacement tous les pistolets pulvérisateurs DeVilbiss, Binks, Finishline et ceux des autres de marque.

6-429
Lubrifiant
Gunners
Mate de
Binks
(Vingt
bouteilles
de 2 oz.)

Compatible avec tous les produits de peinture ; ne contient pas de silicone ou de distillats de pétrole qui peuvent contaminer la peinture. Fiche signalétique disponible sur demande.

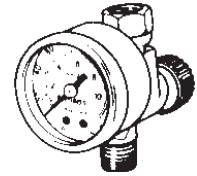
HAV-500 OU HAV-501
Vanne de régulation
(INDIQUÉ HAV-501)

HAV-500 ne dispose pas de manomètre. Utiliser pour contrôler l'utilisation d'air au pistolet.

Respirateur Millennium
3000 à deux cartouches pour
pulvérisation de peinture

Certifié NIOSH, pour une protection respiratoire dans des atmosphères sans danger immédiat pour la vie.

Petit 40-141 Moyen 40-128 Large 40-143

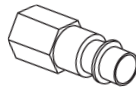
Raccords rapides pour
les pistolets HVLP (Air)
 Type haut débit

HC-4419 Tige
1/4 po NPT(F)
Côté pistolet

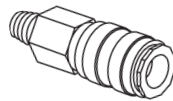

HC-4719 Raccord
1/4 po NPT(M)
Côté flexible

29-3100 Lingettes
nettoyantes Scrubs®

Les lingettes humidifiées Scrubs® sont des serviettes de nettoyage pour les peintres, les tôliers et les mécaniciens qui se déplacent sans avoir nécessairement besoin d'eau.

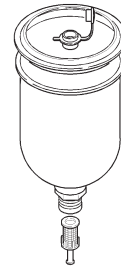
54-6106
1 Qté Godet à aspiration
(gravité)

192219
Support de pistolet

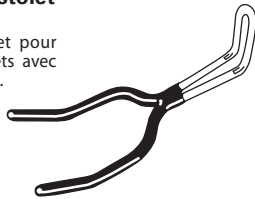
Support de pistolet pour soutenir les pistolets avec des godets à gravité.

KGP-13-K5
Joint de godet

Nécessaire de joint d'étanchéité à l'entrée du liquide pour godets à gravité métalliques.



54-6197
Arrêt de l'aiguille de réglage

Accessoires DeKups® pour les godets à gravité

DPC-60-K10
9oz Universal
x10

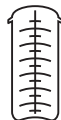

DPC-59-K10
24oz Universal
x10



DPC-61-K10
34oz Universal
x10

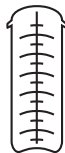

125 µm
DPC-42-K24
x24



125 µm
DPC-65-K24
x24



200 µm
DPC-66-K24
x24



200 µm
DPC-67-K24
x24



DPC-6-K10
x10



DPC-22-K24
x24



DPC-44



DPC-31



DPC-607
x2



DPC-606
x2



DPC-608
x2



9 FL
265 mL
DPC-602
x32



24 FL
710 mL
DPC-601
x32



34 FL
1000 mL
DPC-600
x32

GODETS

DOUBLURES

CONDITIONS DE GARANTIE

Les produits Binks sont couverts contre les vices de matériel et de fabrication par une garantie limitée d'un an de Carlisle Fluid Technologies. L'utilisation de toutes pièces ou accessoires issus d'une source autre que Carlisle Fluid Technologies, annulera toutes les garanties. Pour des informations précises sur la garantie, veuillez contacter le site de Carlisle Fluid Technologies le plus proche, que vous trouverez sur la liste ci-dessous.

Carlisle Fluid Technologies se réserve le droit de modifier sans préavis les spécifications de l'équipement. DeVilbiss®, Ransburg®, MS®, BGK®, et Binks® sont des marques de commerce déposées de Carlisle Fluid Technologies, Inc. ©2017 Carlisle Fluid Technologies, Inc. Tous droits réservés.



Binks fait partie de Carlisle Fluid Technologies, un leader mondial dans le domaine des technologies innovatrices de finition. Pour toute assistance technique ou pour localiser un distributeur agréé, veuillez contacter l'un de nos bureaux de ventes internationaux et de soutien client.

USA/Canada

info@carlisleleft.com
Tél : 1-888-992-4657
Fax : 1-888-246-5732

Mexique

ventas@carlisleleft.com.mx
Tél : 011 52 55 5321 2300
Fax : 011 52 55 5310 4790

Brésil

vendas@carlisleleft.com.br
Tél : +55 11 5641 2776
Fax : 55 11 5641 1256

Royaume-Uni

info@carlisleleft.eu
Tél : +44 (0)1202 571 111
Fax : +44 (0)1202 573 488

France

info@carlisleleft.eu
Tél : +33(0)475 75 27 00
Fax : +33(0)475 75 27 59

Allemagne

info@carlisleleft.eu
Tél : +49 (0) 6074 403 1
Fax : +49 (0) 6074 403 281

Chine

mkt@carlisleleft.com.cn
Tél : +8621-3373 0108
Fax : +8621-3373 0308

Japon

overseas-sales@carlisleleft.co.jp
Tél : 081 45 785 6421
Fax : 081 45 785 6517

Australie

sales@carlisleleft.com.au
Tél : +61 (0) 2 8525 7555
Fax : +61 (0) 2 8525 7575

Pour obtenir les dernières informations sur nos produits, visitez www.carlisleleft.com.





**BINKS „TROPHY“ REIHE
SCHWERKRAFTZUFUHR HVLP, LVMP &
KONVENTIONELL
HANDSPRITZPISTOLE**

(2466-XXXX-XXXX)

CE II 2 G X

Die Binks-Spritzpistole der Schwerkraft-Reihe ist die führende Spritzpistole zum Einsatz in Schwerkraft-Anwendungen, und legt einen neuen Standard in Langlebigkeit, Ergonomie und Zerstäubung fest. Das leichte ergonomische Design bietet einzigartigen Komfort und herausragende Kontrolle. Die modernste Sprühtechnologie wurde integriert, um konsistentes, feines Finish auf einer Vielfalt von industriellen Beschichtungsanwendungen zu erzielen.

Spritzpistolen der Binks Schwerkraft-Reihe werden in drei unterschiedlichen Sprühtechnologien angeboten: HVLP, LVMP und konventionell.



SPEZIFIKATIONEN

Die Trophy HVLP-Reihe an Spritzpistolen kann verwendet werden, um bei hoher Übertragungswirksamkeit gemäß den Richtlinien des „California South Coast Air Quality Management District“ als hochvolumige, Niederdruck-Spritzpistole eingesetzt zu werden.

Maximaler Luftdruck	140 psi / 9,6 bar (P-1)
Spritzpistolengehäuse	Eloxiertes Aluminium
Flüssigkeitsverlauf	Rostfreier Stahl
Flüssigkeitseinlassgröße	3/8" – 19 NPS / BSP(f)
Lufteinlassgröße	1/4 Zoll NPS / BSP(m)
Pistolen-gewicht	13.8 oz. / 394 Gramm (ohne Becher)
Benetzte Teile	Rostfreier Stahl & PTFE

WICHTIG! NICHT ENTSORGEN

Der Kunde ist dafür verantwortlich, dass alle Bediener und das gesamte Wartungspersonal diese Anleitung lesen und verstehen. Kontaktieren Sie Ihre Binks-Vertretung vor Ort, um zusätzliche Kopien dieser Anleitung anzufordern.

LESEN SIE ALLE ANWEISUNGEN BEVOR SIE DIESES BINKS-PRODUKT VERWENDEN.

Auf dieser Teile-Seite werden die Wörter **WARNUNG**, **ACHTUNG** und **HINWEIS** dazu verwendet, wichtige Sicherheitsinformationen wie folgt zu betonen:

! WARNUNG

Gefahren oder unsichere Verfahrensweisen können zu schweren Körperverletzungen, Tod oder erheblichen Sachschaden führen.

! ACHTUNG

Gefahren oder unsichere Verfahrensweisen können zu geringen Körperverletzungen, Produkt- oder Sachschaden führen.

HINWEIS

Wichtige Installations-, Betriebs- und Wartungsinformationen.

! WARNUNG

Lesen Sie die folgenden Warnungen, bevor Sie dieses Gerät verwenden.



BEDIENUNGSANLEITUNG LESEN

Vor der Inbetriebnahme von Endbearbeitungsgeräten alle Sicherheits-, Betriebs- und Wartungsinformationen in der Betriebsanleitung lesen und verstehen.



TRAGEN SIE EINE SCHUTZBRILLE

Das Tragen einer Schutzbrille mit Seitenschildern ist notwendig, um schwere Augenverletzungen oder Blindheit zu vermeiden.



VOR ALLEN WARTUNGSARBEITEN STROM ABSCHALTEN, DRUCK ABLASSEN UND ALLE STROMQUELLEN AUSSCHALTEN

Wenn vor Wartungsarbeiten der Strom nicht abgeschaltet wird, der Druck nicht abgelassen und alle Stromquellen ausschaltet werden, kann das zu schweren Verletzungen oder sogar zum Tod führen.



BEDIENERSCHULUNG

Das gesamte Personal muss vor der Arbeit mit Endbearbeitungsgeräten geschult werden.



GEFAHR BEI GERÄTEMISBRAUCH

Gerätemissbrauch kann zum Bruch, Versagen oder unerwarteten Start und zu schweren Verletzungen führen.



ALLE SCHUTZVORRICHTUNGEN AN ORT UND STELLE BELASSEN

Das Gerät nicht verwenden, wenn die Sicherheitsvorrichtungen entfernt wurden.

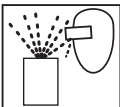

GEFAHR DURCH HERUMFLIEGENDE GEGENSTÄNDE

Verletzungsgefahr durch unter Druck abgelassene Flüssigkeiten oder Gase oder durch Splitter.

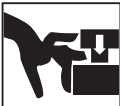

QUETSCHGEFAHR

Bewegliche Teile können Quetschungen und Schnitte verursachen. Quetschstellen sind alle Bereiche mit beweglichen Teilen.



GERÄTE TÄGLICH INSPIZIEREN

Geräte täglich auf verschlissene oder beschädigte Teile inspizieren. Gerät nicht betreiben, wenn der Zustand des Geräts unbekannt ist.



DIE GERÄTE DÜRFEN IN KEINER WEISE MANIPULIERT WERDEN.

Die Geräte dürfen nur nach schriftlicher Genehmigung des Herstellers geändert werden.



ES IST WICHTIG, DASS SIE IM NOTFALL WISSEN, WO UND WIE DIE PISTOLE AUSGESCHALTET WERDEN KANN.



DRUCKABLASSVERFAHREN

Halten Sie sich immer an die Druckablassverfahren in der Geräte-Bedienungsanleitung.



LÄRMGEFAHR

Laute Geräusche können Verletzungen verursachen. Beim Einsatz dieses Geräts kann ein Hörschutz notwendig sein.



STATISCHE LADUNG

Flüssigkeit kann eine statische Ladung entwickeln, die durch angemessene Erdung der Geräte, der zu besprühenden Teile sowie aller anderen elektrisch geladenen Teile im Sprühbereich abgeleitet werden kann. Unsachgemäße Erdung oder Funken können gefährliche Zustände schaffen und zu Brand, Explosion oder Elektroschock sowie anderen schweren Verletzungen führen.



BRAND- UND EXPLOSIONSGEFAHR

Verwenden Sie mit aluminiumbenetzten Teilen nie Lösungsmittel mit 1,1,1-Trichloroethan, Methylenchlorid oder andere halogenierte Kohlenwasserstoff-Lösungsmittel, oder Flüssigkeiten, die solche Lösungsmittel enthalten. Das könnte gefährliche chemische Reaktionen und möglicherweise eine Explosion hervorrufen. Wenden Sie sich an Ihren Flüssigkeitslieferanten, um sicherzugehen, dass die verwendeten Flüssigkeiten mit den Aluminiumteilen kompatibel sind.



PROP 65-WARNUNG

WARNUNG: Dieses Produkt enthält Chemikalien, die im Staate Kalifornien als Ursache für Krebs, Geburtsfehler oder Einschränkung der Fortpflanzungsfähigkeit eingestuft werden.

DER ARBEITGEBER MUSS DEM BEDIENER DES GERÄTS DIESE INFORMATIONEN ZUKOMMEN LASSEN.

ZUSÄTZLICHE SICHERHEITSINFORMATIONEN ZU BINKS- UND DEVILBISS-GERÄTEN FINDEN SIE IM GENERAL EQUIPMENT SAFETY BOOKLET (77-5300).

Produktbeschreibung / Objekt der Erklärung :	Trophy
Dieses Produkt wurde entwickelt zur Verwendung mit:	Wasser- und lösungsmittelhaltige Materialien
Für den Einsatz in explosionsgefährdeten Bereichen geeignet	Zone 1 / Zone 2
Schutzniveau:	II 2 G X
Benannte Stelle Details und Rolle :	TRAC Global Ltd (0891) Unterkünfte für Technische Datei
Diese Konformitätserklärung / Eingliederung wird unter der alleinigen responsibility des Herstellers ausgestellt :	Carlisle Fluid Technologies, 320 Phillips Ave., Toledo, OH 43612

EU -Konformitätserklärung



Der Gegenstand der Erklärung oben beschrieben ist in Übereinstimmung mit den einschlägigen EU-Harmonisierungsgesetz :

Maschinenrichtlinie 2006/42/EG

ATEX-Richtlinie 2014/34/EU

durch Einhaltung der folgenden gesetzlichen Dokumente und harmonisierten Normen:

EN ISO 12100:2010 Sicherheit von Maschinen - Allgemeine Gestaltungsgrundsätze

DIN EN 1953:2013 Spritz- und Sprühgeräte für Beschichtungsstoffe - Sicherheitsanforderungen

EN 1127-1:2011 Explosionsfähige Atmosphären - Explosionsschutz - Grundlagen

EN 13463-1:2009 Nichtelektrische Geräte für den Einsatz in explosionsgefährdeten Bereichen - Grundmethoden und -anforderungen

Bereitstellung aller Bedingungen für die sichere Verwendung / Installation angegeben innerhalb der Produkthandbücher mit und auch in Übereinstimmung mit allen anwendbaren lokalen Regeln der Technik installiert eingehalten wurden.

Unterzeichnet für und im
Namen von Carlisle Fluid
Technologies:

DJ Hasselschwert
11-Jul-16

(Vice President Global
Product Development)
Toledo, OH 43612

BINKS SPRITZPISTOLE DER SCHWERKRAFT-REIHE

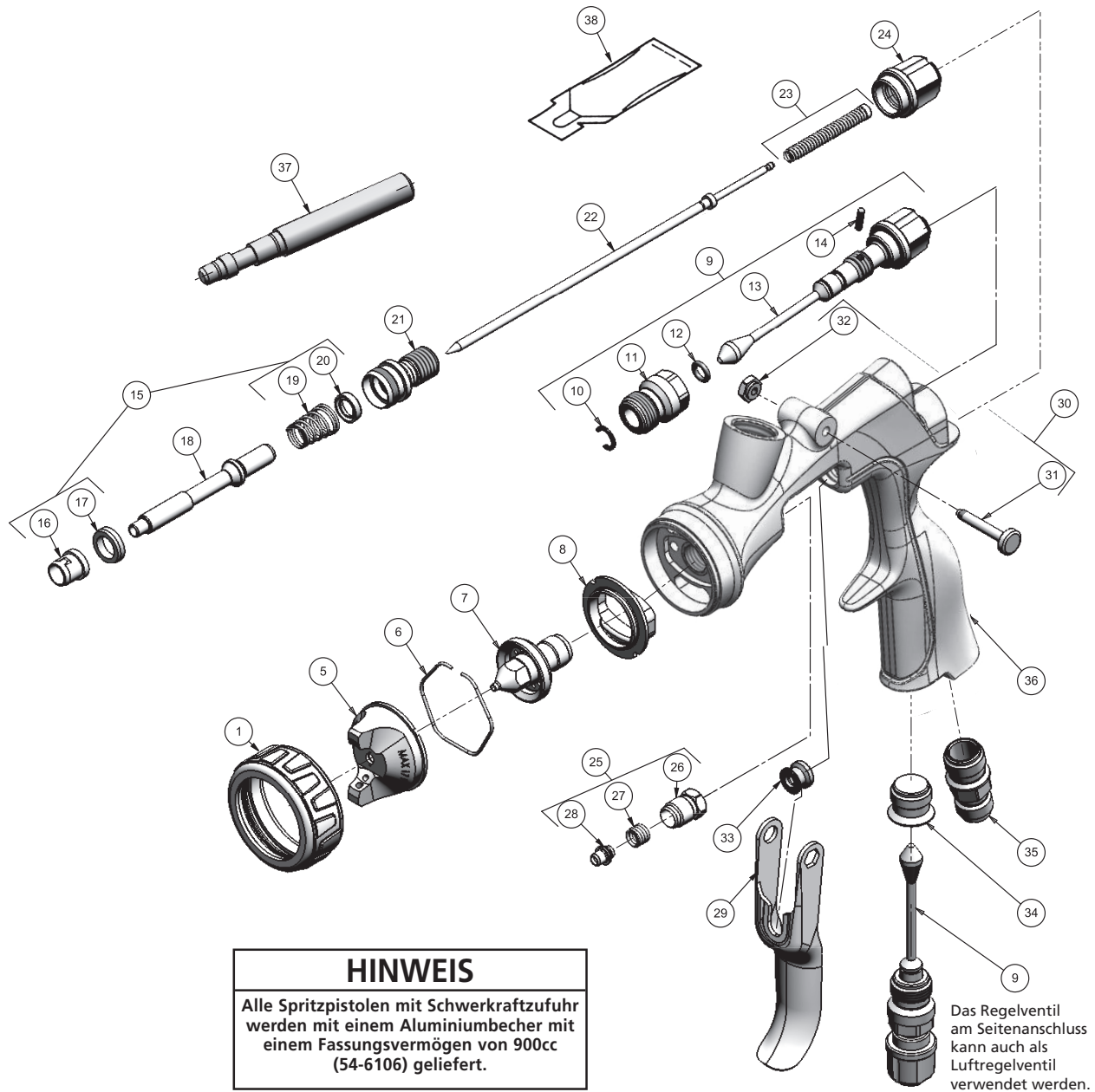

NUMMERIERUNGSSYSTEM FÜR NORMALGRÖSSEN-SPRITZPISTOLEN DER BINKS-REIHE VON SCHWERKRAFT-SPRITZPISTOLEN

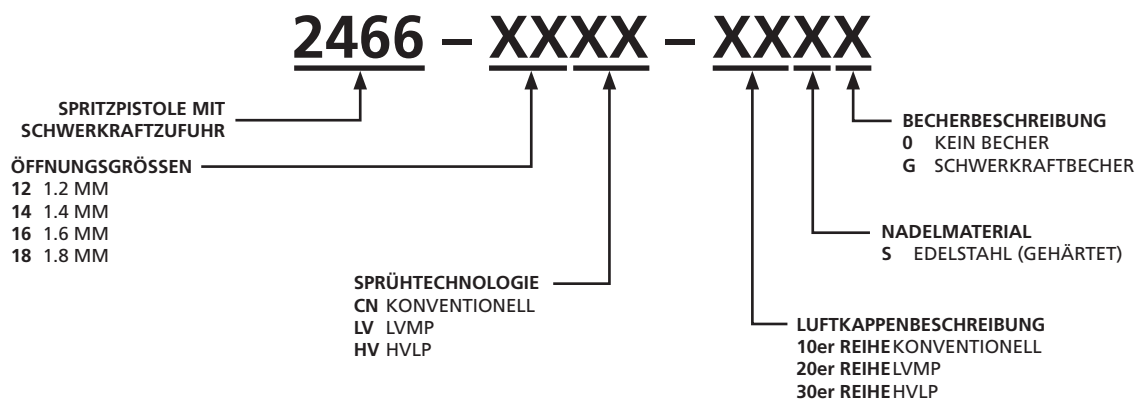

Siehe Tabelle auf Seite 6 für die gesamte Pistolenbaugruppe.

TABELLE 1: TEILELISTE FÜR DIE BINKS SPRITZPISTOLE DER SCHWERKRAFT-REIHE

ARTIKELNR.	TEILNUMMER	BESCHREIBUNG	ANZ.	ARTIKELNR.	TEILNUMMER	BESCHREIBUNG	ANZ.
1	54-6120	LUFTKAPPEN-HALTERING-BAUGRUPPE	1	24	54-6111	KNOPF – NADELVERSTELLUNG	1
5	SIEE TABELLEN AUF SEITE 7	LUFTKAPPE	1	25	54-6130-K	NADELPAKUNGS-KIT (STANDARD)	1
6	JGA-156-K10	FEDERBÜGEL (10ER PACK)	1	26	-----	■ MUTTER – PACKUNG	1
7	SIEHE NACHSTEHENDE TABELLEN	FLÜSSIGKEITSDÜSE	1	27	-----	■ FEDER FÜR PACKUNG	1
8	54-6102-K3	UMLENKBLECH/ABSCHIEDER (3ER SATZ)	1	28	-----	□ ■ ▼ NADELPAKUNG (STANDARD)	1
9	54-6122	VENTILBAUGRUPPE SEITENANSCHLUSS	1	29	54-4360	AUSLÖSER	1
10	-----	+ Δ HALTECLIP	1	30	54-6132-K	AUSLKÖSERSCHRAUBEN-MUTTER-SATZ	1
11	-----	+ KÖRPERBUCHSE	1	31	-----	○ AUSLÖSERSCHRAUBE	1
12	-----	+ Δ O-RING	1	32	-----	○ AUSLÖSERMUTTER	1
13	-----	+ SEITENANSCHLUSSSTANGE	1	33	54-3513	SPINDELKAPPE	1
14	-----	+ Δ STIFT	1	34	SN-11	STECKER	1
15	54-6131-K	□ LUFTVENTIL-SERVICEKIT	1	35	54-6112	MUFFE– LUFTEINLASS	1
16	-----	• DICHTUNG VORNE - LUFTVENTIL	1	36	-----	PISTOLENKÖRPER MIT FLÜSSIGKEITSEINLASS	1
17	-----	• LUFTVENTILDICHTUNG VORNE	1	37	-----	WERKZEUG – DICHTUNGSEINSATZ	1
18	54-6109	□ LUFTVENTILSPINDEL	1	38	-----	SCHMIERMITTEL GUNNER'S MATE (3 CC BEUTEL)	1
19	-----	• LUFTVENTILFEDER	1				
20	-----	• DICHTUNG HINTEN - LUFTVENTIL	1				
21	SN-66	GEHÄUSE	1				
22	47-6825	NADEL - EDELSTAHL (STD)	1				
23	-----	□ FEDER/PLATTEN-BAUGRUPPE	1				
	54-6133-K3	FEDER/PLATTEN-BAUGRUPPE (3ER SATZ)	1				

+	IM LIEFERUMFANG VON 54-6122 ENTHALTENE TEILE
■	IM LIEFERUMFANG VON 54-6130-K ENTHALTENE TEILE
▼	AUCH IM 3er SATZ ERHÄLTICH SN-2-K3
•	IM LIEFERUMFANG VON 54-6131-K ENTHALTENE TEILE

○	IM LIEFERUMFANG VON 54-6132-K ENTHALTENE TEILE
Δ	GTI-428-K5 SEITENANSCHLUSS-REPARATURKIT
□	IM LIEFERUMFANG VON 54-6135 ENTHALTENE TEILE

TABELLE 2:
EDELSTAHL (GEHÄRTET)
FLÜSSIGKEITSDÜSEN - STD.

ÖFFNUNGSGRÖSSE EDELSTAHL-FLÜSSIGKEITSDÜSE		FLÜSSIGKEITSDÜSE TEILNUMMER
.039"	1,0 mm	45-11050-10
.047"	1,2 mm	45-11050-12
.055"	1,4 mm	45-11050-14
.063"	1,6 mm	45-11050-16
.071"	1,8 mm	45-11050-18

TABELLE 3:
TEST-LUFTKAPPEN-KITS-
OPTIONAL

KONVENTIONELL	
54-6141-K	12-C KIT
LVMP	
54-6147-K	23-L KIT
HVLP	
54-6152-K	32-H KIT – HVLP

BINKS SPRITZPISTOLEN DER SCHWERKRAFT-REIHE ANLEITUNG ZUR NADEL- UND DÜSENAUSWAHL

TABELLE 4: VORBEREITUNG KONVENTIONELLER PISTOLEN

ZU SPRÜHENDE FLÜSSIGKEIT	VOLLSTÄNDIGE PISTOLENBAUGRUPPE TEILNUMMER	FLÜSSIGKEITSDÜSE UND LUFTKAPPE
DÜNN 5-25 CENTIPOISE 15-19 Sek. Zahn 2 Becher Waschgrundierer, Farbstoffe, Färbemittel, Lösungsmittel, Wasser, Tinten, Versiegelungsmittel, Lacke, Schmierstoffe, Zinkchromat, Kunststoffe	2466-14CN-12SG	1,4 mm (.055") X 12C
	2466-16CN-12SG	1,6 mm (.063") X 12C
MITTEL 25-70 CENTIPOISE 20-30 Sek. Zahn 2 Becher synthetisches Emaille, Lacke, Schellack, Füllmittel, Grundierungen, Epoxyfarben, Urethan, Schmierstoffe, Wachsemulsionen, Emaille	2466-16CN-12SG	1,6 mm (.063") X 12C
	2466-18CN-12SG	1,8 mm (.070") X 12C

TABELLE 5: LVMP- PISTOLENVORBEREITUNG

ZU SPRÜHENDE FLÜSSIGKEIT	VOLLSTÄNDIGE PISTOLENBAUGRUPPE TEILNUMMER	FLÜSSIGKEITSDÜSE UND LUFTKAPPE
DÜNN 5-25 CENTIPOISE 15-19 Sek. Zahn 2 Becher Waschgrundierer, Farbstoffe, Färbemittel, Lösungsmittel, Wasser, Tinten, Versiegelungsmittel, Lacke, Schmierstoffe, Zinkchromat, Kunststoffe	2466-12LV-23SG	1,2 mm (.067") X 23L
	2466-14LV-23SG	1,4 mm (.055") X 23L
MITTEL 25-70 CENTIPOISE 20-30 Sek. Zahn 2 Becher synthetisches Emaille, Lacke, Schellack, Füllmittel, Grundierungen, Epoxyfarben, Urethan, Schmierstoffe, Wachsemulsionen, Emaille	2466-14LV-23SG	1,4 mm (.055") X 23L
	2466-18LV-23SG	1,8 mm (.070") X 23L

TABELLE 6: VORBEREITUNG KONVENTIONELLER PISTOLEN

ZU SPRÜHENDE FLÜSSIGKEIT	VOLLSTÄNDIGE PISTOLENBAUGRUPPE TEILNUMMER	FLÜSSIGKEITSDÜSE UND LUFTKAPPE
DÜNN 5-25 CENTIPOISE 15-19 Sek. Zahn 2 Becher Waschgrundierer, Farbstoffe, Färbemittel, Lösungsmittel, Wasser, Tinten, Versiegelungsmittel, Lacke, Schmierstoffe, Zinkchromat, Kunststoffe	2466-12HV-32SG	1,2 mm (.047") X 32H
	2466-14HV-32SG	1,4 mm (.055") X 32H
MITTEL 25-70 CENTIPOISE 20-30 Sek. Zahn 2 Becher synthetisches Emaille, Lacke, Schellack, Füllmittel, Grundierungen, Epoxyfarben, Urethan, Schmierstoffe, Wachsemulsionen, Emaille	2466-14HV-32SG	1,4 mm (.055") X 32H
	2466-18HV-32SG	1,8 mm (.070") X 32H

BINKS SPRITZPISTOLE DER FÜR SPRITZPISTOLEN MIT SCHWERKRAFTZUFUHR TABELLEN ZUR LUFTKAPPEN- UND FLÜSSIGKEITSDÜSENAUSWAHL

TABELLE 7: TABELLE ZUR AUSWAHL KONVENTIONELLER LUFTKAPPEN UND FLÜSSIGKEITSDÜSEN							
Luftkappe	Luftkappen-Teilnr.	Sprühmusterbereich	CFM bei 30 PSI	CFM bei 50 PSI	CFM bei 70 PSI	Flüssigkeitsdüse	Typische Beschichtungen
12-C	46-6501	4 – 12 Zoll	8,3	12,1	14,2	45-11050 Reihe, 1,2 mm – 1,8 mm	Lacke, Lackfarben, Decklacke, Klebstoffe mit geringer Viskosität

TABELLE 8: AUSWAHLTABELLE LVMP-LUFTKAPPEN UND FLÜSSIGKEITSDÜSEN					
Luftkappe	Luftkappen-Teilnr.	Sprühmusterbereich	CFM bei 30 PSI Pistoleneinlass (dynamisch)	Flüssigkeitsdüse	Typische Beschichtungen
23-L	46-6511	4 – 12 Zoll	10,6	45-11050 Reihe, 1,2 mm – 1,8 mm	Lacke, Lackfarben, Decklacke, Klebstoffe mit geringer Viskosität
24-L	46-6512	2 – 6 Zoll	14,3	45-11050 Reihe, 1,0 mm – 1,8 mm	Kleine Muster-Anwendungen von Farbstoffe, Lacke, Emaille, Acrylfarben

TABELLE 9: AUSWAHLTABELLE HVLP-LUFTKAPPEN UND FLÜSSIGKEITSDÜSEN						
Luftkappe	Luftkappen-Teilnr.	Sprühmusterbereich	SCFM bei 10 PSI Kappendruck (dynamisch)	Pistoleneinlass PSI bei 10 PSI an Luftkappe (dynamisch)	Flüssigkeitsdüse	Typische Beschichtungen
32-H	46-6518	8 – 14 Zoll	15,5	26	45-11050 Reihe, 1,2 mm – 1,8 mm	Lacke, Emaille, Vielfarbig, Multispez., Antihaft-Beschichtungen, Schnitt-Latex

TABELLE 10: TABELLE ZUR AUSWAHL VON RUNDSTRAHL- LUFTKAPPEN UND FLÜSSIGKEITSDÜSEN (OPTIONAL)							
Luftkappe	Luftkappen-Teilnr.	Sprühmusterbereich	CFM bei 30 PSI	CFM bei 50 PSI	CFM bei 70 PSI	Flüssigkeitsdüse	Typische Beschichtungen
16	46-6505	2 – 4 Zoll	5,6	7,8	10,5	45-11050 Reihe, 1,2 mm – 1,8 mm	Lacke, Emaille

INSTALLATIONSARTEN

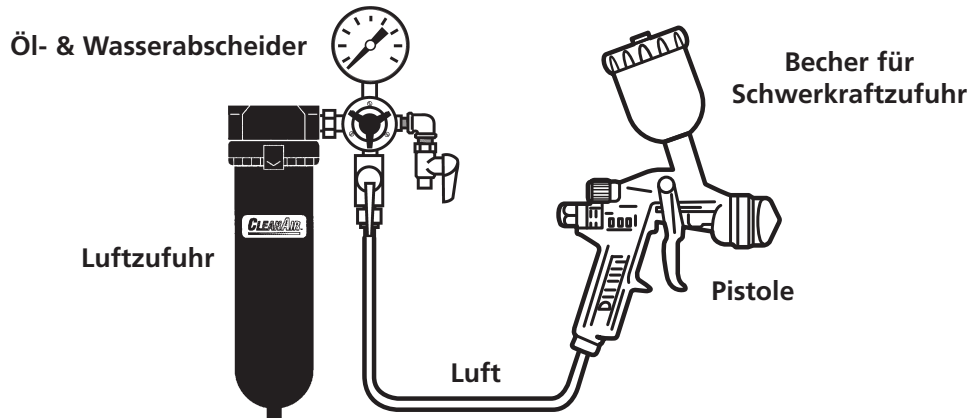

Der Luftdruck für die Zerstäubung wird am Auszieher eingestellt. Der Flüssigkeitsfluss wird mithilfe des Flüssigkeitsventil-Reglerknopfs an der Spritzpistole, der Lackviskosität und des Luftdrucks eingestellt.



SCHWERKRAFTZUFUHR VORBEREITUNG

Bei Spritzpistolen mit Schwerkraftzufuhr ist der Becher über der Pistole angebracht. Die Schwerkraft drückt die Flüssigkeit in die Pistole.

Vorteile: diese Methode ermöglicht schnelle Farbänderungen und ist praktisch für kleinere Anwendungen und Ausbesserungsarbeiten. In Spritzpistolen mit Schwerkraftzufuhr kann das gesamte Beschichtungsmaterial eingesetzt werden, wodurch Abfall reduziert wird.

LUFTDRUCK

Der Sprühdruk muss richtig eingestellt werden, damit ein Luftdruckabfall zwischen dem Regler und der Spritzpistole möglich ist.

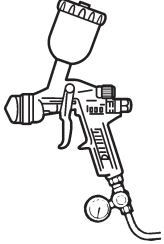
 <p>5/16 Zoll</p>	<p>LUFTZUFUHR 60 PSI</p> <p>Querschnitt mit Vergleich der Innenschlauchdurchmesser (tatsächliche Größe). 60 lbs. Regeldruck</p>	 <p>1/4 Zoll</p>
<p>EMPFOHLEN</p> <p>48 PSI am Spritzpistoleneinlass</p> <p>25 Fuß Schlauch mit einem Innendurchmesser von 5/16 Zoll führt zu einem Druckabfall von 12 PSI zwischen der Luftzufuhr und der Spritzpistole. Daher empfiehlt Binks die Verwendung eines Schlauchs mit einem Innendurchmesser von 5/16 Zoll.</p>		<p>NICHT EMPFOHLEN</p> <p>Nur 34 PSI am Spritzpistoleneinlass</p> <p>25 Fuß Schlauch mit einem Innendurchmesser von 1/4 Zoll führt zu einem Druckabfall von 26 PSI zwischen der Luftzufuhr und der Spritzpistole.</p>

Ein Öl- und Wasserabscheider ist wichtig.

Es ist so gut wie unmöglich ein feines Sprüh-Finish ohne den Einsatz eines guten Öl- und Wasserabscheiders zu erreichen.

Ein Regler/Abscheider hat zwei Aufgaben. Er eliminiert Blasendbildung und Flecken, indem Wasser und Öl aus der Sprühluft entfernt werden und er ermöglicht eine präzise Luftdruckregelung an der Spritzpistole.

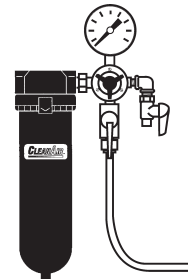

Verwenden Sie Öl- und Wasserabscheider und Regler von DeVilbiss. Wenden Sie sich für die Modelle an Ihren Händler vor Ort.

MONTAGEANLEITUNG

Um optimale Übertragungswirksamkeit zu erreichen, wird empfohlen, dass nur der für das zu sprühende Material notwendige Druck angewandt wird.

HINWEIS

Bei der Verwendung von HVLP sicherstellen, dass der auf Seite 7 aufgelistete Einlassdruck nicht überschritten wird.

1. Pistole mit einem Leitungsschlauch mit einem Innendurchmesser von mindestens 5/16 Zoll an eine saubere, trockene und ölfreie Luftversorgung anbringen.

HINWEIS

Je nach Länge des Schlauchs kann ein Schlauch mit einem größeren Innendurchmesser notwendig sein. Bringen Sie am Spritzpistolengriff ein Luftdruckmessgerät an. Siehe Seite 7 für Betriebsdrücke. Es wird empfohlen, dass nur der für das zu sprühende Material notwendige Druck angewandt wird. Übermäßiger Druck schafft zusätzliches Übersprühen und reduziert die Übertragungswirksamkeit.

HINWEIS

Wenn Schnellkupplungen erforderlich sind, nur Schnellkupplungen für hohe Fließraten verwenden, die zur Verwendung mit HVLP zugelassen sind. Andere Arten lassen nicht genügend Luft für den korrekten Spritzpistolbetrieb durch.

HINWEIS

Wenn ein Luftregelventil am Spritzpistoleneinlass verwendet werden, Typ HAV-501 verwenden.

HINWEIS

Vor der Verwendung der Spritzpistole sollte diese mit Lösungsmittel ausgespült werden, um sicherzugehen, dass die Flüssigkeitsleitungen sauber sind.

BETRIEB

SCHWERKRAFTMODELLE

1. Beschichtungsmaterial nach Anleitung des Herstellers mischen und abseihen.
2. Den Becher bis ca. 2 cm vom obere Becherrand füllen.
3. Am Becherdeckel anbringen.
4. Flüssigkeitsreglerknopf (24) im Uhrzeigersinn drehen, um eine Bewegung der Flüssigkeitsnadel zu vermeiden.
5. Seitenanschlussregler (9) zur vollständigen Öffnung gegen den Uhrzeigersinn drehen.
6. Ggf. Einlassdruck einstellen.
7. Flüssigkeitsreglerknopf gegen den Uhrzeigersinn drehen, bis die erste Gewindelinie zu sehen ist.

8. Sprühtest vornehmen. Wenn das Finish zu trocken ist, Luftmenge durch die Reduzierung des Luftenlassdrucks reduzieren.
9. Wenn das Finish zu nass ist, den Flüssigkeitsfluss durch Drehen des Flüssigkeitsreglerknopfs (24) im Uhrzeigersinn reduzieren. Wenn das Sprühmuster zu grob ist, muss der Luftenlassdruck erhöht werden. Wenn es zu fein ist, muss der Einlassdruck reduziert werden.
10. Die Sprühmustergröße kann durch Drehen des Seitenanschlussreglers (9) im Uhrzeigersinn reduziert werden.
11. Pistole senkrecht zur besprühenden Oberfläche halten.
12. Die empfohlene Entfernung zwischen der Oberfläche und der Spritzpistole beträgt ca. 20 cm.
13. Immer zuerst die Kanten besprühen. Jedes Sprühen um mindestens 75% überlappen. Spritzpistole bei konstanter Geschwindigkeit bewegen.
14. Wenn die Spritzpistole nicht verwendet wird, Luftzufuhr abschalten und Druck ablassen.

PRÄVENTIVMASSNAHMEN UND REINIGUNG

Zum Reinigen der Luftkappe und der Flüssigkeitsdüse das Äußere mit einer steifen Bürste abbürsten. Zur Reinigung der Kappenlöcher kann ein spitzer Gegenstand, wie ein Zahnstocher verwendet werden. Wenn Draht oder ein harter Gegenstand verwendet wird, vorsichtig vorgehen, damit die Oberfläche nicht zerkratzt oder die Löcher keine Gratspuren bekommen, was zu einem verzerrten Sprühmuster führen kann.

Zum Reinigen der Flüssigkeitsleitungen überschüssiges Material aus der Spritzpistole entfernen und diese dann mit einer speziellen Waschlösung waschen. Das Äußere der Spritzpistole mit einem feuchten Tuch abwischen. Die Spritzpistole niemals vollkommen in Lösungsmittel oder Reinigungsmittel eintauchen, weil das für den Schmierstoff schädlich ist und die Standzeit der Spritzpistole verkürzt.

HINWEIS

Die Flüssigkeitsdüse (7) oder die Flüssigkeitsnadel sollten immer gemeinsam ausgewechselt werden. Bei der Verwendung von verschlissenen Teilen können Flüssigkeitslecks auftreten. Siehe Seite 4. Wechseln Sie zu diesem Zeitpunkt auch die Packung aus. Die Flüssigkeitsdüse mit einem Drehmoment von 230–240 inch-lbs festdrehen. Nicht zu fest anziehen.

⚠ ACHTUNG

Um Schaden an der Flüssigkeitsdüse (7) oder der Flüssigkeitsnadel (22) zu vermeiden, sichergehen, dass entweder 1) der Auslöser gezogen und gehalten wird, während die Flüssigkeitsdüse festgezogen oder gelöst wird, oder 2) dass der Flüssigkeitsreglerknopf entfernt wird, (24) um den Federdruck am Nadelansatz zu reduzieren.

SCHWERKRAFTBECHER. Überschüssiges Material leeren und den Becher reinigen. Sicherzugehen, dass das Entlüftungsloch im Deckel frei ist.

DEMONTAGE- UND MONTAGEVERFAHREN

NADEL- UND DÜSEN-DEMONTAGE UND MONTAGE

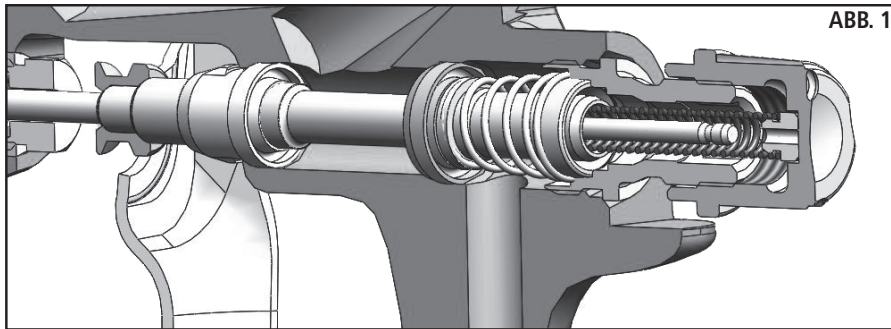

DEMONTAGE

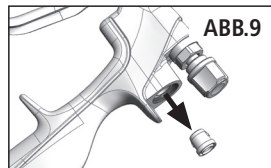
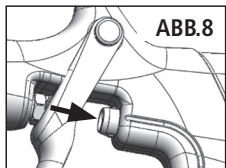
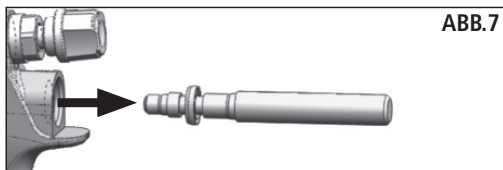
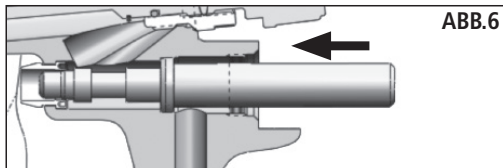
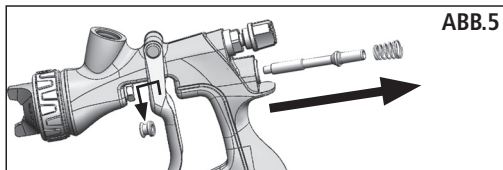
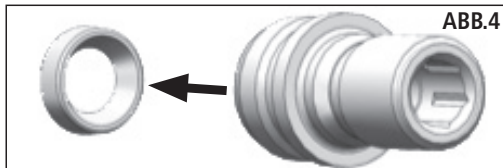
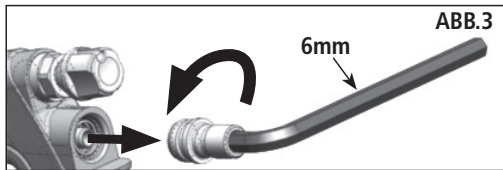
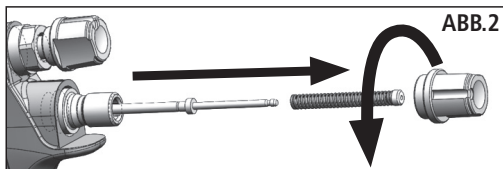

MONTAGE

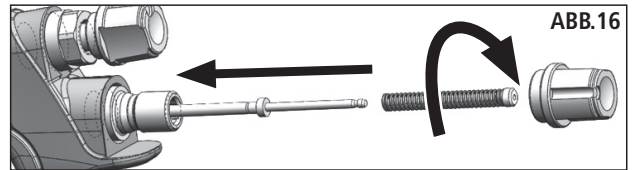
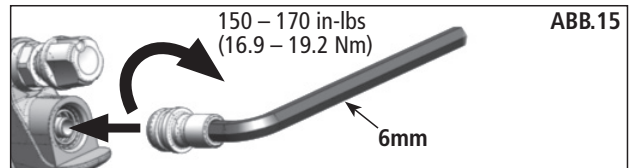
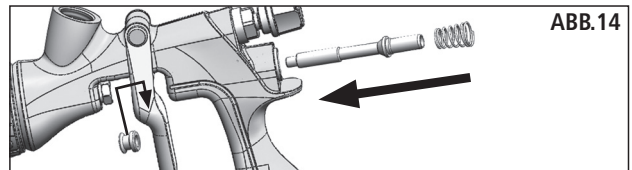
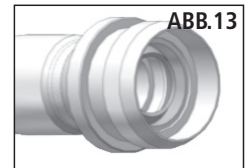
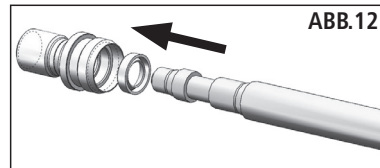
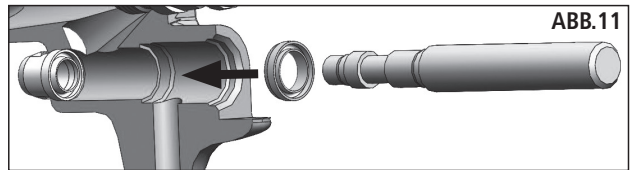
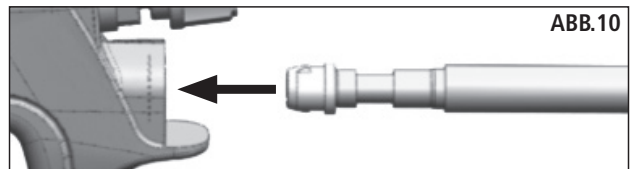

WARTUNG – FLÜSSIGKEITSDÜSEN- UND UMLENKBLECH-DEMONTAGE UND MONTAGE

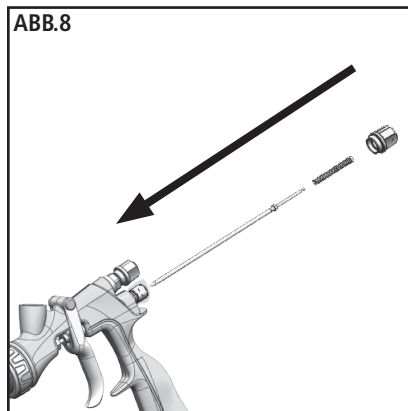
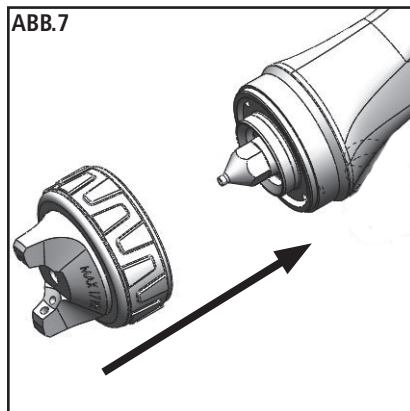
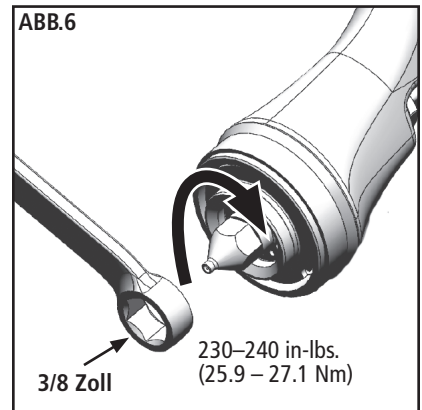
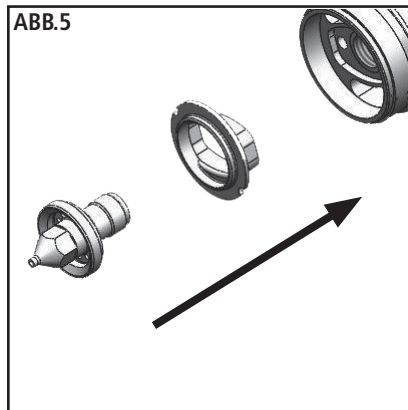
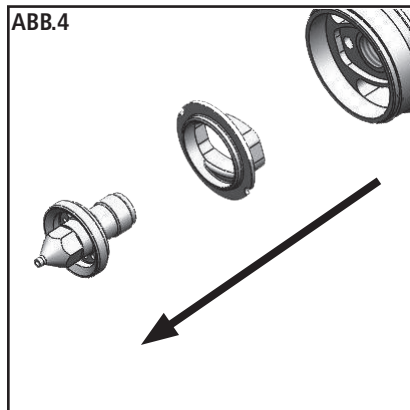
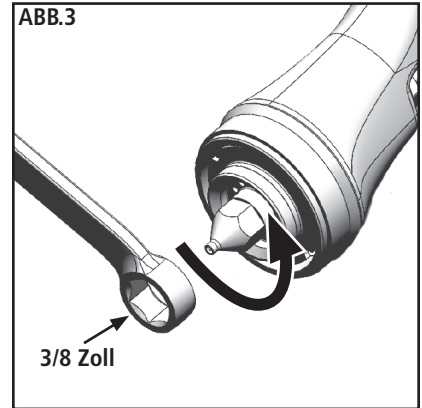
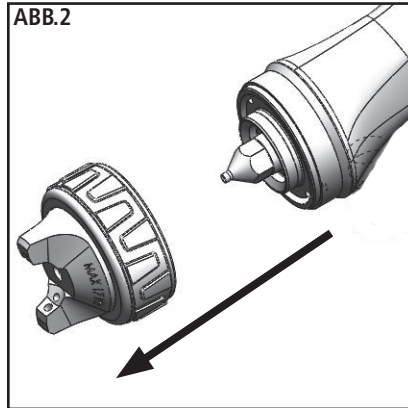
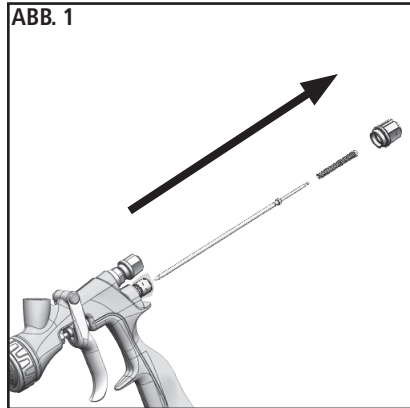

LUFTKAPPEN-INDEXIERSTIFT (54-6184) MONTAGE
(OPTIONAL – 90° STUFENEINTEILUNG)

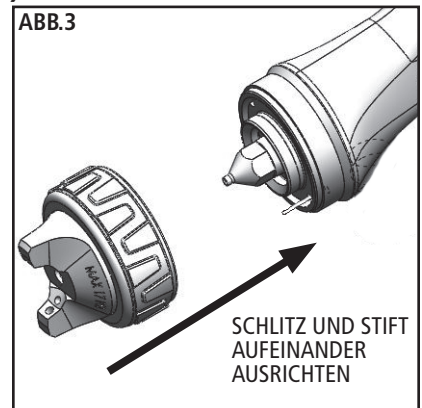
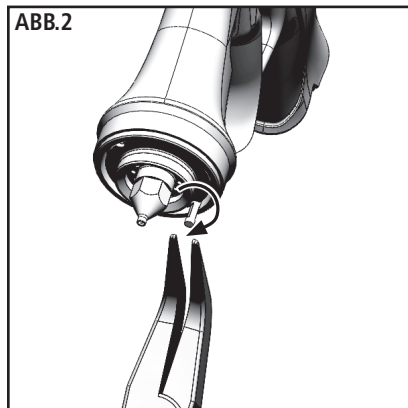
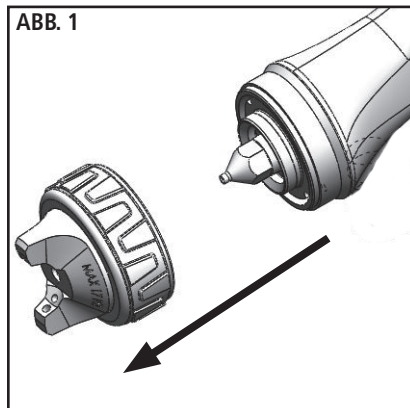



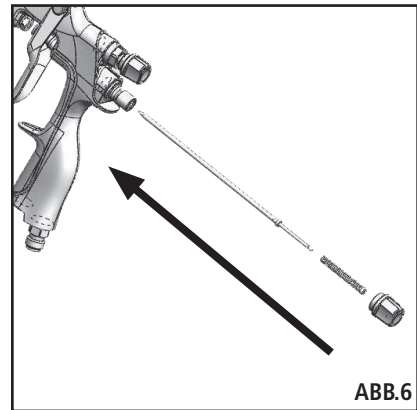
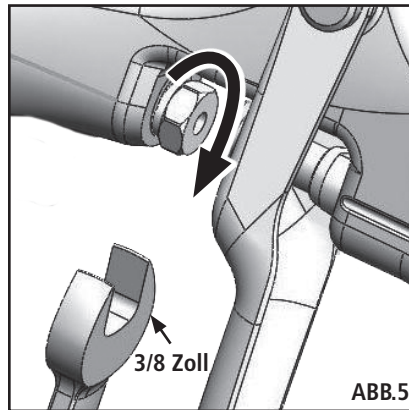
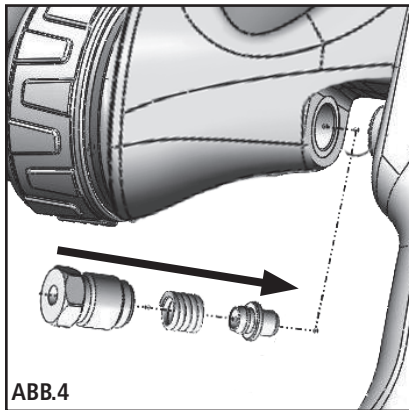
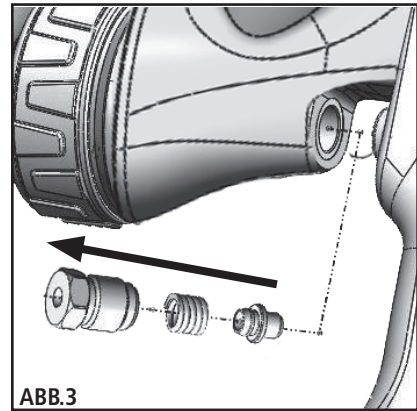
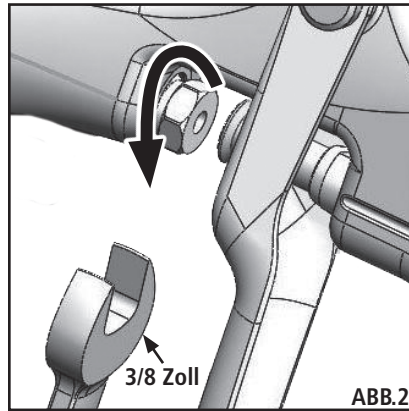
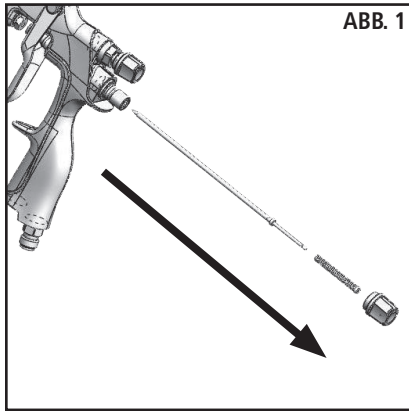

WARTUNG- NADELPACKUNGS-DEMONTAGE UND -MONTAGE

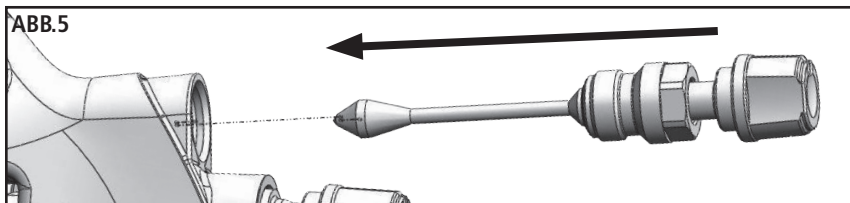
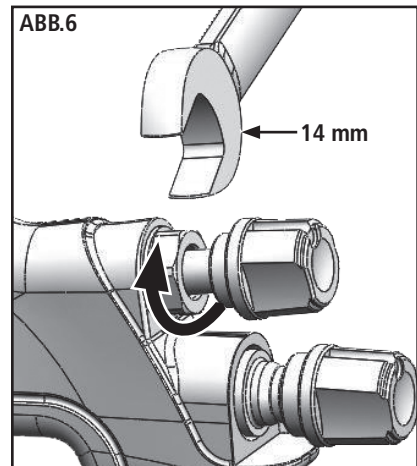
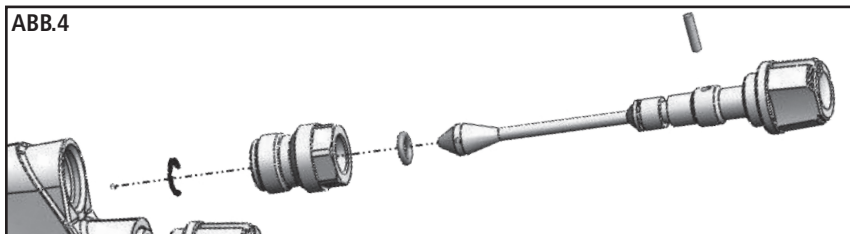
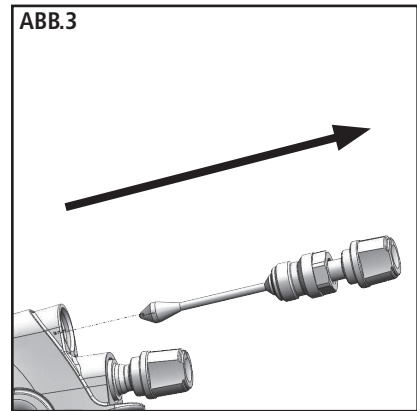
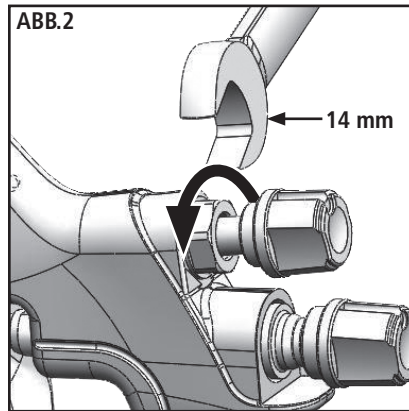
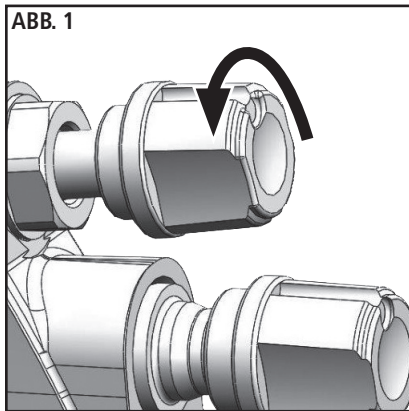

WARTUNG- SEITENANSCHLUSS-DEMONTAGE UND -MONTAGE



FEHLERBEHEBUNG

ZUSTAND	URSACHE	KORREKTUR
Starkes Muster oben oder unten 	Hornlöcher verstopft Verstopfung am oberen oder unteren Teil der Flüssigkeitsspitze. Kappe und/oder Spitzenpassung verschmutzt.	Sauber. Schliere mit nichtmetallischer Spitze. Sauber. Sauber.
Starkes Seitenmuster links oder rechts 	Hornlöcher links oder rechts verstopft. Schmutz an der linken oder rechten Seite der Flüssigkeitsspitze. Methoden, um Sprühmuster zu korrigieren, die an der Oberseite, an der Unterseite, rechts oder links zu stark sind: 1. Bestimmen Sie, ob die Luftkappe oder die Flüssigkeitsspitze verstopft ist. Machen Sie dazu ein Test-Sprühbild. Drehen Sie dann die Kappe um eine halbe Drehung und machen Sie ein weiteres Test-Sprühbild. Wenn der Sprühfehler umgekehrt ist, ist die Luftkappe verstopft. Reinigen Sie die Luftkappe wie zuvor beschrieben. 2. Wenn der Sprühfehler nicht umgekehrt ist, ist die Flüssigkeitsdüse verstopft. Prüfen Sie die Kante der Flüssigkeitsspitze auf feine Gratschäden. Entfernen Sie den Grat mit trockenem oder nassem 600er Sandpapier. 3. Prüfen Sie die Öffnung auf angetrocknete Farbe und waschen Sie diese ggf. mit Lösungsmittel ab.	Sauber. Schliere mit nichtmetallischer Spitze. Sauber.
Starkes Sprühbild Mitte 	Zu viel Flüssigkeit für die Sprühluft. Der Materialfluss überschreitet die Kapazität der Luftkappe. Streuerstellventil ist zu niedrig eingestellt. Sprühdruk zu niedrig. Material zu dick.	Luftdruck und Flüssigkeitsfluss ausgleichen. Spritzmusterbreite mithilfe des Streuerstellventils vergrößern. Flüssigkeitsfließgeschwindigkeit verringern oder erhöhen. Einstellen. Druck erhöhen. Auf die richtige Konsistenz verdünnen.
Gespaltenes Spritzmuster 	Sprühluftdruck zu hoch. Flüssigkeit fließt zu langsam. Streuerstellventil ist zu hoch eingestellt.	Am Transformator oder an der Pistole reduzieren. Flüssigkeitsfluss erhöhen (Spritzpistolbetrieb beschleunigen) Einstellen.
Zuckendes oder vibrierendes Sprühen 	*Lose(r) oder beschädigte(r) Flüssigkeitsspitze/-ansatz. Zu wenig Material. Behälter zu weit geneigt. Flüssigkeitsleitung verstopft. Trockene oder lose Flüssigkeitsnadel-Packungsmutter.	Festziehen oder auswechseln. Wieder auffüllen. Gerader halten. Mit Lösungsmittel rückspülen. Schmierer oder festziehen.
Kein rundes Sprühmuster	Streuerstellschraube sitzt nicht richtig. Luftkappen-Haltering ist locker.	Festziehen oder auswechseln. Reinigen und auswechseln.
Sprüht nicht	Kein Luftdruck an der Pistole. Flüssigkeitsnadelstellschraube nicht weit genug offen. Flüssigkeit zu schwer für Schwerkraftzufuhr.	Luftzufuhr und Leitungen prüfen und Pistolen-Luftleitungen durchblasen. Flüssigkeitsnadelstellschraube öffnen. Material verdünnen und/oder eine größere Spitze verwenden.
Farbblasen im Becher	Flüssigkeitsspitze sitzt nicht fest.	Spitze festziehen.
Flüssigkeit leckt oder tropft vom Becherdeckel	Becherdeckel lose. Schmutziges Gewinde im Becher oder Deckel. Gesprungener Becher oder Deckel.	Deckel festschrauben. Sauber. Becher oder Deckel auswechseln.

*Häufigstes Problem..

FEHLERBEHEBUNG

ZUSTAND	URSACHE	KORREKTUR
Mangelndes Spritzmuster	Unzureichender Materialfluss. Niedriger Sprühluftdruck.	Flüssigkeitsstellschraube zur ersten Gewindelinie schrauben oder eine größere Spitze verwenden. Luftdruck erhöhen und Spritzpistole wieder ausgleichen.
Übermäßiges Übersprühen	Zu hoher Sprühluftdruck. Spritzpistole ist zu weit von der Arbeitsoberfläche entfernt. Unsachgemäße Streichbewegungen (Bogenbildung, zu schnell).	Druck reduzieren. Auf die richtige Entfernung einstellen. Langsam und parallel zur Arbeitsoberfläche arbeiten.
Zu viel Sprühnebel	Zu viel Verdünnungsmittel oder Verdünnungsmittel trocknet zu schnell. Zu hohe Sprühkraft (Luftdruck).	Material entsprechend neu mischen. Luftdruck reduzieren.
Trockenes Sprühen	Luftdruck zu hoch. Pistolenspitze ist zu weit von der Arbeitsoberfläche entfernt. Pistole wird zu schnell bewegt. Pistole ist nicht richtig eingestellt.	Luftdruck reduzieren. Auf die richtige Entfernung einstellen. Langsamer sprühen. Einstellen.
Flüssigkeit leckt von der Packungsmutter	Packungsmutter ist lose. Packung verschlissen oder trocken.	Festziehen, aber Nadel nicht einklemmen. Auswechseln oder schmieren.
Flüssigkeit leckt oder tropft von der Vorderseite der Spritzpistole	Packungsmutter sitzt zu fest. Trockenlauf. Flüssigkeitsspitze oder -nadel verschlissen oder beschädigt. Fremdkörper in der Spitze. Flüssigkeitsnadelspitze ist abgebrochen. Falsche Nadelgröße oder Nadelspitze.	Einstellen. Schmieren. Spitze und Nadel auswechseln. Saubere. Auswechseln. Auswechseln.
Flüssigkeit tropft oder leckt vom Becherboden	Becher wurde nicht fest an der Spritzpistole angebracht. Becherdichtung verschlissen oder fehlt. Bechergewinde schmutzig.	Festziehen. Becherdichtung auswechseln. Reinigen.
Unebene Farbschichten	Zu starker Materialfluss. Material zu dünn. Spritzpistole wird in einem Winkel geschwenkt oder Spritzpistole wird zu langsam bewegt.	Spritzpistole einstellen oder Flüssigkeitsfluss reduzieren. Richtig mischen oder dünne Schichten auftragen. Spritzpistole im richtigen Winkel halten und die richtige Technik anwenden.
Dünnes, sandig grobes Finish trocknet bevor es austritt	Spritzpistole ist zu weit von der Arbeitsoberfläche entfernt. Zu hoher Luftdruck. Falsches Verdünnungsmittel.	Entfernung prüfen. Normalerweise rund 20 cm. Luftdruck reduzieren und Sprühmuster prüfen. Mischenweisungen des Lackherstellers befolgen.
Dickes Orangenhaut-Finish	Spritzpistole ist nahe an der der Arbeitsoberfläche. Zu viel Material wird grob versprüht. Luftdruck zu niedrig. Falsches Verdünnungsmittel. Material nicht richtig gemischt. Raue, ölige, schmutzige Oberfläche.	Entfernung prüfen. Normalerweise rund 20 cm. Mischenweisungen des Lackherstellers befolgen. Luftdruck erhöhen und Flüssigkeitsfluss reduzieren. Mischenweisungen des Lackherstellers befolgen. Mischenweisungen des Lackherstellers befolgen. Richtig reinigen und vorbereiten.

ZUBEHÖR

HAF-507-K12 Whirlwind™ In-Line Luftfilter Satz mit 12

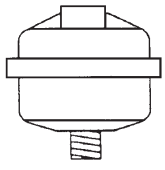

Entfernt Wasser, Öl und Schmutz aus der Luftleitung.

192212 Professionelles Spritzpistolen Reinigungsset



Enthält sechs Präzisionswerkzeuge, die alle DeVilbiss, Binks Finishline und andere Marken-Spritzpistolen wirksam reinigen.

6-429 Binks Gunners Mate Schmierstoff (Zwanzig 2 oz. Flaschen)



Kompatibel mit allen Lackmaterialien; enthält kein Silikon oder Petroleumdestillate, die den Lack kontaminieren könnten. Material-Sicherheitsdatenblätter auf Anfrage erhältlich.

HAV-500 OR HAV-501 Stellventil (HAV-501 ABGEBILDET)

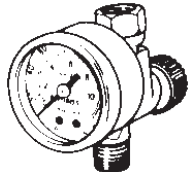

HAV-500 hat kein Druckmessgerät. Zur Kontrolle der Luftmenge an der Spritzpistole verwendet.

Millennium 3000 Twin Cartridge Farbspray-Doppel-Atemschutzmaske



NIOSH-zertifiziert für Atemschutz in Atmosphären, die keine unverzügliche Lebensgefahr darstellen.

Klein 40-141	Mittel 40-128	Groß 40-143
-----------------	------------------	----------------

Schnellverbindungen für HVLP-Spritzpistolen (Luft) Hoher Durchfluss

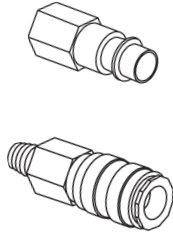

HC-4419 Stange 1/4" NPT(F) Pistolenende
HC-4719 Verbindungsteil 1/4" NPT(M) Schlauchende

29-3100 Scrubs® Handreinigungstücher



Scrubs® sind feuchte Handreinigungstücher für Maler, Reparateure und Mechaniker, die Sie immer bei sich tragen können und für die kein Wasser notwendig ist.

54-6106 1 Qt. Schwerkraftbecher (Aluminium)

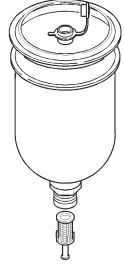

192219 Pistolenhalterung

Pistolenhalterung zum Halten von Spritzpistolen mit Schwerkraftbechern.



KGP-13-K5 Becherdichtung











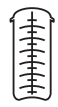
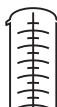





Bei der Verwendung von Metall-Schwerkraftbechern ist eine Flüssigkeitseinlassdichtung notwendig.



54-6197 Nadelverstellung Drossel



DeKups® Zubehör für Schwerkraftzufuhrbecher

DPC-60-K10 9oz Universal x10	DPC-59-K10 24oz Universal x10	DPC-61-K10 34oz Universal x10	DPC-42-K24 125 µm x24	DPC-66-K24 200 µm x24	DPC-6-K10 x10
					
DPC-607 x2	DPC-606 x2	DPC-608 x2	DPC-65-K24 125 µm x24	DPC-67-K24 200 µm x24	DPC-22-K24 x24
					
DPC-602 x32	DPC-601 x32	DPC-600 x32	DPC-44	DPC-31	
					
HÜLLEN			EINSÄTZE		

GARANTIE

Carlisle Fluid Technologies erteilt für Binks-Produkte eine beschränkte Garantie von einem Jahr für Material und Verarbeitung. Bei der Verwendung von Teilen oder Zubehör von einem anderen Hersteller als Carlisle Fluid Technologies erlöschen alle Garantien. Spezifische Garantieinformationen erhalten Sie von den nachstehend aufgelisteten Carlisle Fluid Technologies -Niederlassungen in Ihrer Nähe.

Carlisle Fluid Technologies behält sich das Recht vor, die Gerätespezifikationen ohne vorherige Benachrichtigung zu ändern. DeVilbiss®, Ransburg®, MS®, BGK® und Binks® sind eingetragene Warenzeichen von Carlisle Fluid Technologies, Inc. ©2017 Carlisle Fluid Technologies, Inc. Alle Rechte vorbehalten.



Binks gehört zur Carlisle Fluid Technologies, ein global führender Konzern im Bereich innovativer Endbearbeitungstechnologien. Für technische Hilfe oder um einen autorisierten Händler zu finden, können Sie einen unserer internationalen Verkaufs- und Kundenservice-Standorte kontaktieren.

USA/Kanada

info@carlisleleft.com
Tel: 1-888-992-4657
Fax: 1-888-246-5732

Mexiko

ventas@carlisleleft.com.mx
Tel: 011 52 55 5321 2300
Fax: 011 52 55 5310 4790

Brasilien

vendas@carlisleleft.com.br
Tel: +55 11 5641 2776
Fax: 55 11 5641 1256

Vereinigtes Königreich

info@carlisleleft.eu
Tel: +44 (0)1202 571 111
Fax: +44 (0)1202 573 488

Frankreich

info@carlisleleft.eu
Tel: +33(0)475 75 27 00
Fax: +33(0)475 75 27 59

Deutschland

info@carlisleleft.eu
Tel: +49 0 6074 403 1
Fax: +49 0 6074 403 281

China

mkt@carlisleleft.com.cn
Tel: +8621-3373 0108
Fax: +8621-3373 0308

Japan

overseas-sales@carlisleleft.co.jp
Tel: 081 45 785 6421
Fax: 081 45 785 6517

Australien

sales@carlisleleft.com.au
Tel: +61 0 2 8525 7555
Fax: +61 0 2 8525 7575

Für die neuesten Informationen über unsere Produkte, besuchen www.carlisleleft.com.





SERIE "TROPHY" BINKS
ALIMENTAZIONE A GRAVITÀ HVLP,
LVMP E CONVENZIONALE
PISTOLE A SPRUZZO MANUALI

(2466-XXXX-XXXX)

CE II 2 G X

La pistola a spruzzo con serbatoio superiore serie Trophy Binks è la pistola a spruzzo ideale per l'uso in applicazioni di spruzzatura con alimentazione a gravità e definisce un nuovo standard per durabilità, ergonomia e atomizzazione. Il modello ergonomico leggero offre comfort e controllo senza pari. È stata incorporata l'ultima tecnologia all'avanguardia per ottenere finiture costanti, di ottima qualità per applicazioni che usano un'ampia gamma di rivestimenti industriali.

Le pistole a spruzzo con serbatoio superiore serie Trophy Binks sono disponibili in tre diverse tecnologie di atomizzazione: HVLP, LVMP e convenzionale.



Le pistole a spruzzo serie HVLP Trophy possono essere usate per funzionare ad alte efficienze di trasferimento in conformità con la normativa ecologica della "California South Coast Air Quality Management District" (Distretto di tutela della qualità dell'aria della costa meridionale della California) come pistole a pressione ad alto volume, bassa pressione.

SPECIFICHE TECNICHE

Massima pressione aria	140 psi / 9,6 bar (P-1)
Corpo della pistola	Alluminio anodizzato
Percorso del fluido	Acciaio inox
Dimensioni ingresso fluido	3/8" NPS / BSP(f)
Dimensioni ingresso aria	1/4" NPS / BSP(m)
Peso pistola	13,8 once / 394 grammi (senza serbatoio)
Parti bagnate	Acciaio inox e PTFE

IMPORTANTE NON DISTRUGGERE

Il cliente deve fare leggere attentamente questo manuale a tutti gli operatori e al personale addetto alla manutenzione. Rivolgersi al rappresentante Binks di zona per richiedere copie aggiuntive di questo manuale.

LEGGERE TUTTE LE ISTRUZIONI PRIMA DI USARE QUESTO PRODOTTO BINKS.

In questo listino parti, le parole **AVVERTENZA**, **ATTENZIONE** e **NOTA** sono usate per segnalare importanti informazioni cautelative, nel seguente modo:

⚠ AVVERTENZA
Rischi e pratiche pericolose che potrebbero dare luogo a gravi infortuni, morte o seri danni a proprietà.

⚠ ATTENZIONE
Rischi e pratiche pericolose che potrebbero dare luogo a infortuni non gravi, danni al prodotto o alla proprietà.

NOTA
Informazioni importanti sull'installazione, l'uso o la manutenzione.

⚠ AVVERTENZA

Leggere le seguenti avvertenze prima di usare questo apparecchio.



LEGGERE QUESTO MANUALE

Prima di usare apparecchi di finitura, leggere attentamente tutte le informazioni sulla sicurezza, l'uso e la manutenzione incluse nel manuale d'uso.



INDOSSARE PROTEZIONE OCULARE

Se non si usa protezione oculare con schermi laterali si rischiano gravi lesioni oculari o cecità.



DISECCITARE, DEPRESSURIZZARE, SCOLLEGARE E BLOCCARE TUTTE LE FONTI DI ALIMENTAZIONE DURANTE LA MANUTENZIONE

Se non si diseccitano, depressurizzano, scollegano e bloccano tutte le fonti di alimentazione prima di eseguire interventi di manutenzione sugli apparecchi si rischiano gravi infortuni o morte.



FORMAZIONE DEGLI OPERATORI

Tutto il personale deve completare l'appropriata formazione prima di usare apparecchi di finitura.



RISCHI DELL'USO ERRATO DEGLI APPARECCHI

L'uso errato degli apparecchi può causare la rottura, guasti o avviamento imprevisto degli apparecchi con conseguenti gravi infortuni.



TENERE IN POSIZIONE LE PROTEZIONI DEGLI APPARECCHI

Non usare l'apparecchio se i dispositivi di sicurezza sono stati rimossi.

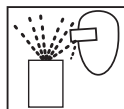

RISCHIO DI LANCIO DI OGGETTI

Si può essere feriti da liquidi o gas liberati sotto pressione o detriti lanciati nell'aria.



PUNTO AD ALTO RISCHIO

Parti in movimento possono schiacciare e tagliare. I punti ad alto rischio sono praticamente tutte le zone in cui vi sono parti in movimento.



CONTROLLARE GLI APPARECCHI OGNI GIORNO

Verificare che non vi siano parti logorate o rotte ogni giorno. Non usare l'apparecchio se non si è sicuri delle sue condizioni.



NON MODIFICARE MAI L'APPARECCHIO

Non modificare l'apparecchio a meno che non sia stato approvato per iscritto dal produttore.



SAPERE DOVE E COME SPEGNERE L'APPARECCHIO IN CASO DI EMERGENZE.



METODO DI SFIATO DELLA PRESSIONE

Seguire sempre il metodo di sfiato della pressione descritto nel manuale d'uso.



RISCHIO DA RUMORE

L'udito può essere danneggiato da forte rumore. Può essere necessaria protezione acustica quando si usa questo apparecchio.



CARICA STATICA

Il fluido può sviluppare una carica statica che deve essere dissipata attraverso la messa a terra idonea dell'apparecchio, di oggetti da spruzzare e tutti gli altri oggetti a conduzione elettrica nell'area di lavoro. La messa a terra inadeguata o scintille possono creare una condizione di rischio e dare luogo a incendi, esplosione o elettrocuzione e altri seri infortuni.



RISCHIO DI INCENDIO ED ESPLOSIONI

Non usare mai trichloroetano, cloruro di metilene, altri solventi a base di idrocarburi alogenati o fluidi che contengono tali solventi in apparecchi con parti in alluminio bagnate. Questo tipo di utilizzo può generare una reazione chimica grave con il rischio di esplosione. Consultare il fornitore del fluido per assicurarsi che i fluidi usati siano compatibili con le parti di alluminio.



AVVERTENZA PROP 65

AVVERTENZA Questo prodotto contiene agenti chimici che nello Stato della California sono considerati causare cancro e anomalie congenite o altri danni all'apparato riproduttivo.

SPETTA AL DATORE DI LAVORO FORNIRE QUESTE INFORMAZIONI ALL'OPERATORE DELL'APPARECCHIO.

PER ULTERIORI INFORMAZIONI SULLA SICUREZZA RELATIVE AGLI APPARECCHI BINKS E DEVILBISS, CONSULTARE L'OPUSCOLO GENERALE PER LA SICUREZZA DEGLI APPARECCHI (77-5300).

Descrizione del prodotto / Oggetto della dichiarazione :	Trophy
Il presente Prodotto è destinato all'uso con:	Materiali a base solvente e acqua
Adatto per l'uso in aree pericolose:	Zona 1 / Zona 2
Livello protezione:	II 2 G X
Notificato dettagli del corpo e il ruolo :	TRAC Global Ltd (0891) Presentazione di Fascicolo tecnico
Questa dichiarazione di conformità / incorporazione viene rilasciata sotto l'esclusiva responsabilità del produttore :	Carlisle Fluid Technologies, 320 Phillips Ave., Toledo, OH 43612

Dichiarazione di conformità EU



L'oggetto della dichiarazione di cui sopra è conforme alla pertinente normativa di armonizzazione dell'Unione :

Direttiva macchine 2006/42/CE

Direttiva ATEX 2014/34/EU

conformemente ai seguenti documenti e standard armonizzati:

EN ISO 12100:2010 Sicurezza del macchinario - Principi generali di progettazione

BS EN 1953:2013 Attrezzatura di nebulizzazione e spruzzatura per materiali di rivestimento - Requisiti di sicurezza

EN 1127-1:2011 Atmosfere esplosive - Prevenzione dell'esplosione - Concetti fondamentali

EN 13463-1:2009 Apparecchi non elettrici destinati ad essere utilizzati in atmosfere potenzialmente esplosive - Metodo e requisiti di base

Fornire tutte le condizioni di uso sicuro / installazione dichiarato nei manuali dei prodotti sono state rispettate e anche installato in accordo con i codici locali applicabili pratica .

Firmato nome e per conto di
Carlisle Fluid Technologies:

DJ Hasselschwert
11-Jul-16

(Vice Presidente : sviluppo
globale del prodotto)

Toledo, OH 43612

PISTOLA A SPRUZZO CON SERBATOIO SUPERIORE SERIE "TROPHY" BINKS

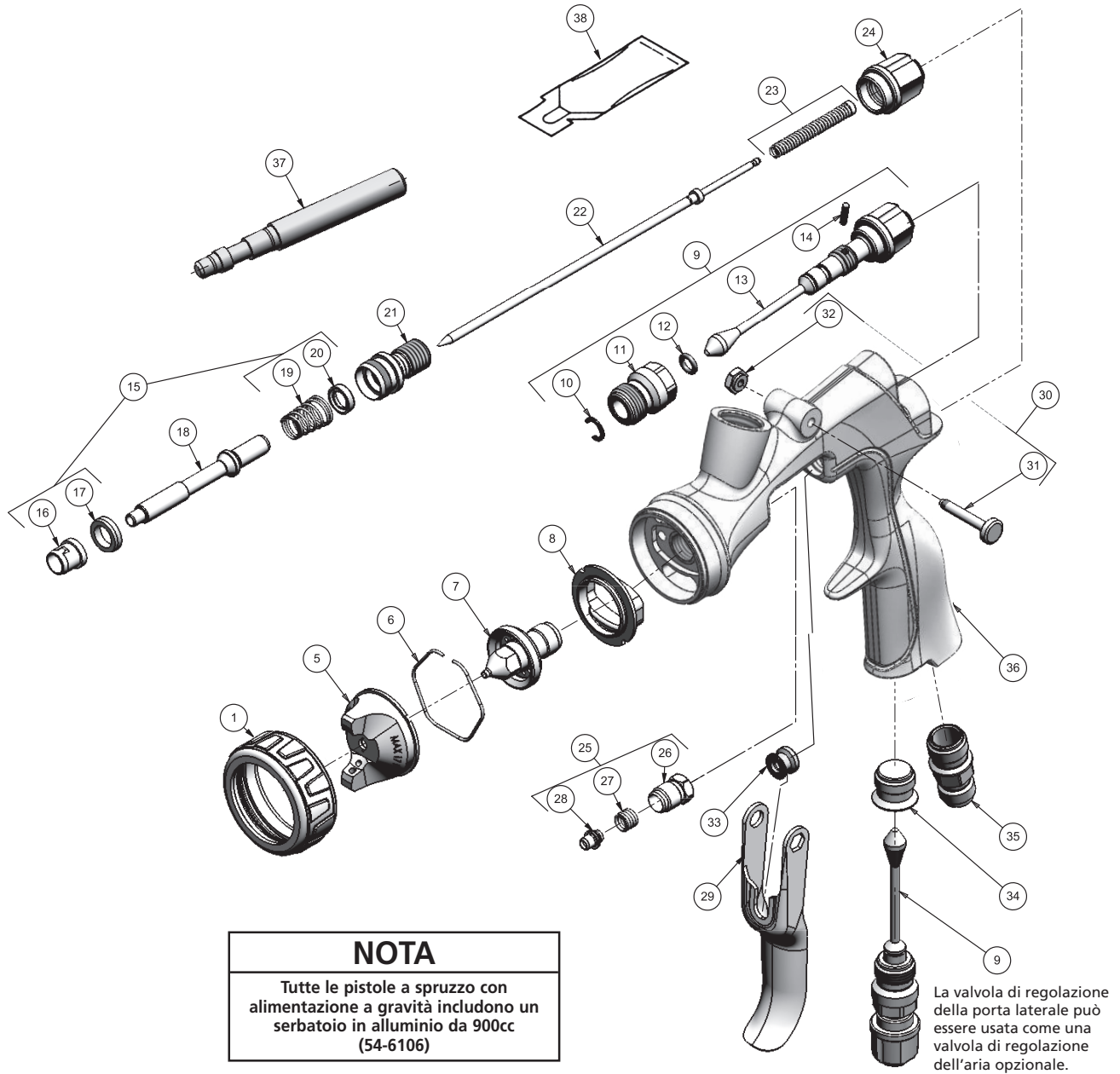

NOTA
 Tutte le pistole a spruzzo con alimentazione a gravità includono un serbatoio in alluminio da 900cc (54-6106)

La valvola di regolazione della porta laterale può essere usata come una valvola di regolazione dell'aria opzionale.

SISTEMA DI IDENTIFICAZIONE NUMERICA PER LE PISTOLE A SPRUZZO CON SERBATOIO SUPERIORE SERIE "TROPHY" BINKS A DIMENSIONI INTERE

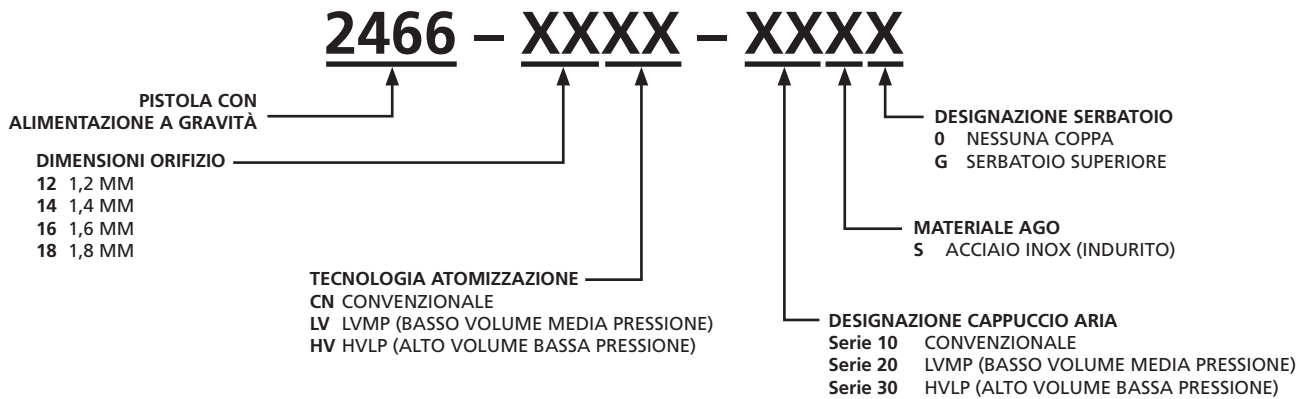

Vedere la tabella a pagina 6 per i gruppi pistola completi.

TABELLA 1: LISTINO PARTI PISTOLA A SPRUZZO CON SERBATOIO SUPERIORE SERIE "TROPHY" BINKS

ARTICOLO N.	CODICE	DESCRIZIONE	QTÀ	ARTICOLO N.	CODICE	DESCRIZIONE	QTÀ
1	54-6120	GRUPPO ANELLO DI FERMO CAPPuccio ARIA	1	24	54-6111	KIT GIUNTO AGO (STANDARD)	1
5	CFR. TABELLE A PAGINA 7	CAPPuccio ARIA	1	25	54-6130-K	DADO - GIUNTO	1
6	JGA-156-K10	CLIP A MOLLA (KIT DI 10)	1	26	-----	■ MOLLA PER GIUNTO	1
7	CFR. TABELLE QUI SOTTO	UGELLO FLUIDO	1	27	-----	■ GIUNTO AGO (STANDARD)	1
8	54-6102-K3	DEFLETTORE/SEPARATORE (KIT DI 3)	1	28	-----	□ ■ ▼ GRILLETTO	1
9	54-6122	GRUPPO VALVOLA PORTA LATERALE	1	29	54-4360	KIT DADO VITE GRILLETTO	1
10	-----	+ Δ CLIP DI FERMO	1	30	54-6132-K	VITE GRILLETTO	1
11	-----	+ BOCCOLA CORPO	1	31	-----	○ DADO GRILLETTO	1
12	-----	+ Δ O-RING	1	32	-----	○ CAPPuccio ALBERO	1
13	-----	+ STELO PORTA LATERALE	1	33	54-3513	TAPPO	1
14	-----	+ Δ CHIODO	1	34	SN-11	RACCORDO - INGRESSO ARIA	1
15	54-6131-K	□ KIT MANUTENZIONE VALVOLA ARIA	1	35	54-6112	CORPO PISTOLA CON INGRESSO FLUIDO	1
16	-----	• SIGILLO ANTERIORE – VALVOLA ARIA	1	36	-----	ATTREZZO – INSERIMENTO SIGILLO	1
17	-----	• SIGILLO VALVOLA ARIA ANTERIORE	1	37	-----	GUNNER'S MATE (BORSA DA 3 CC)	1
18	54-6109	□ ALBERO VALVOLA ARIA	1	38	-----	GUNNER'S MATE (3 CC BORSA)	1
19	-----	• MOLLA VALVOLA ARIA	1				
20	-----	• SIGILLO POSTERIORE – VALVOLA ARIA	1				
21	SN-66	ALLOGGIAMENTO	1				
22	47-6825	AGO - ACCIAIO INOX (STANDARD)	1				
23	-----	□ GRUPPO MOLLA/CUSCINETTO	1				
	54-6133-K3	GRUPPO MOLLA/CUSCINETTO (KIT DI 3)	1				

+	PARTI INCLUSE NEL 54-6122	○	PARTI INCLUSE NEL 54-6132-K
■	PARTI INCLUSE NEL 54-6130-K	Δ	KIT DI RIPARAZIONE PORTA LATERALE GTI-428-K5
▼	DISPONIBILI ANCHE NEL KIT DI 3 SN-2-K3	□	PARTI INCLUSE NEL 54-6135
•	PARTI INCLUSE NEL 54-6131-K		

**TABELLA 2:
UGELLI FLUIDO ACCIAIO INOX
(INDURITO) - STANDARD**

DIMENSIONI ORIFIZIO UGELLO FLUIDO INOX		CODICE UGELLO FLUIDO
0,039"	1,0 mm	45-11050-10
0,047"	1,2 mm	45-11050-12
0,055"	1,4 mm	45-11050-14
0,063"	1,6 mm	45-11050-16
0,071"	1,8 mm	45-11050-18

**TABELLA 3:
KIT CAPPucci ARIA
PROVA - OPZIONALI**

CONVENZIONALE	
54-6141-K	12-C KIT
LVMP	
54-6147-K	23-L KIT
HVLP	
54-6152-K	32-H KIT – HVLP

GUIDA ALLA SELEZIONE DI AGO E UGELLO PER LA PISTOLA A SPRUZZO CON SERBATOIO SUPERIORE SERIE "TROPHY" BINKS

TABELLA 4: IMPOSTAZIONI PISTOLA CONVENZIONALE

TIPO DI FLUIDO DA SPRUZZARE	CODICE GRUPPO COMPLETO PISTOLA	UGELLO FLUIDO E CAPPUCCIO ARIA
SOTTILE 5-25 CENTIPOISE 15-19 sec. Zahn 2 cup primer di lavaggio, tinte, coloranti, solventi, acqua, inchiostri, sigillanti, lacche, lubrificanti, cromati di zinco, acrilici	2466-14CN-12SG	1,4 mm (0,055") X 12C
	2466-16CN-12SG	1,6 mm (0,063") X 12C
MEDIO 25-70 CENTIPOISE 20-30 sec. Zahn 2 cup smalti sintetici, vernici, gommalacca, riempitivi, primer, resine epossidiche, uretani, lubrificanti, emulsioni di cera, smalti	2466-16CN-12SG	1,6 mm (0,063") X 12C
	2466-18CN-12SG	1,8 mm (0,070") X 12C

TABELLA 5: IMPOSTAZIONI PISTOLA LVMP

TIPO DI FLUIDO DA SPRUZZARE	CODICE GRUPPO COMPLETO PISTOLA	UGELLO FLUIDO E CAPPUCCIO ARIA
SOTTILE 5-25 CENTIPOISE 15-19 sec. Zahn 2 cup primer di lavaggio, tinte, coloranti, solventi, acqua, inchiostri, sigillanti, lacche, lubrificanti, cromati di zinco, acrilici	2466-12LV-23SG	1,2 mm (0,067") X 23L
	2466-14LV-23SG	1,4 mm (0,055") X 23L
MEDIO 25-70 CENTIPOISE 20-30 sec. Zahn 2 cup smalti sintetici, vernici, gommalacca, riempitivi, primer, resine epossidiche, uretani, lubrificanti, emulsioni di cera, smalti	2466-14LV-23SG	1,4 mm (0,055") X 23L
	2466-18LV-23SG	1,8 mm (0,070") X 23L

TABELLA 6: IMPOSTAZIONI PISTOLA HVLP

TIPO DI FLUIDO DA SPRUZZARE	CODICE GRUPPO COMPLETO PISTOLA	UGELLO FLUIDO E CAPPUCCIO ARIA
SOTTILE 5-25 CENTIPOISE 15-19 sec. Zahn 2 cup primer di lavaggio, tinte, coloranti, solventi, acqua, inchiostri, sigillanti, lacche, lubrificanti, cromati di zinco, acrilici	2466-12HV-32SG	1,2 mm (0,047") X 32H
	2466-14HV-32SG	1,4 mm (0,055") X 32H
MEDIO 25-70 CENTIPOISE 20-30 sec. Zahn 2 cup smalti sintetici, vernici, gommalacca, riempitivi, primer, resine epossidiche, uretani, lubrificanti, emulsioni di cera, smalti	2466-14HV-32SG	1,4 mm (0,055") X 32H
	2466-18HV-32SG	1,8 mm (0,070") X 32H

TABELLE DI SELEZIONE DEL CAPPUCCIO ARIA E UGELLO FLUIDO PER LA PISTOLA A SPRUZZO CON SERBATOIO SUPERIORE SERIE "TROPHY" BINKS

TABELLA 7: TABELLA DI SELEZIONE DI CAPPUCCI ARIA E UGELLI FLUIDO CONVENZIONALI							
Cappuccio aria	Codice cappuccio aria	Distanza del getto	CFM @ 30 PSI	CFM @ 50 PSI	CFM @ 70 PSI	Ugello fluido	Rivestimenti tipici
12-C	46-6501	4 – 12"	8,3	12,1	14,2	Serie 45-11050, 1,2 mm – 1,8 mm	Lacche, smalti, strati di copertura, adesivi a bassa viscosità

TABELLA 8: LVMP - BASSO VOLUME MEDIA PRESSIONE TABELLA DI SELEZIONE DI CAPPUCCI ARIA E UGELLI FLUIDO					
Cappuccio aria	Codice cappuccio aria	Distanza del getto	CFM @30 PSI Ingresso pistola (dinamico)	Ugello fluido	Rivestimenti tipici
23-L	46-6511	4 – 12"	10,6	Serie 45-11050, 1,2 mm – 1,8 mm	Lacche, smalti, strati di copertura, adesivi a bassa viscosità
24-L	46-6512	2 – 6"	14.3	Serie 45-11050, 1,0 mm – 1,8 mm	Piccole applicazioni del modello di coloranti, lacche, smalti, acrilici

TABELLA 9: HVLP - ALTO VOLUME BASSA PRESSIONE TABELLA DI SELEZIONE DI CAPPUCCI ARIA E UGELLI FLUIDO						
Cappuccio aria	Codice cappuccio aria	Distanza del getto	SCFM @ 10 PSI Pressione cappuccio (dinamica)	Ingresso pistola PSI @ 10 PSI al cappuccio aria (dinamica)	Ugello fluido	Rivestimenti tipici
32-H	46-6518	8 – 14"	15,5	26	Serie 45-11050, 1,2 mm – 1,8 mm	Lacche, smalti, multicolori, multi-spec, rivestimenti antiadesivi, latex tagliato

TABELLA 10: TABELLA DI SELEZIONE DI CAPPUCCI ARIA E UGELLI FLUIDO PER PISTOLA ROTONDA (OPZIONALE)							
Cappuccio aria	Codice cappuccio aria	Distanza del getto	CFM @ 30 PSI	CFM @ 50 PSI	CFM @ 70 PSI	Ugello fluido	Rivestimenti tipici
16	46-6505	2 – 4"	5,6	7,8	10,5	Serie 45-11050, 1,2 mm – 1,8 mm	Lacche, smalti

TIPI DI INSTALLAZIONE

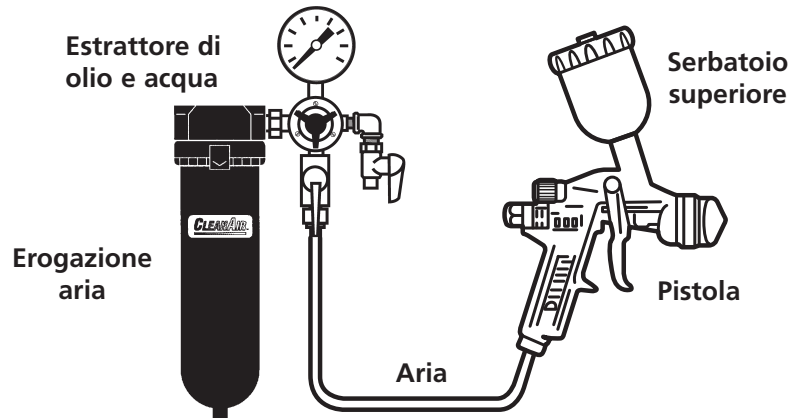

La pressione dell'aria per l'atomizzazione è regolata in corrispondenza dell'estrattore. Il flusso del fluido viene regolato dalla manopola di controllo della valvola del fluido sulla pistola, dalla viscosità della vernice e dalla pressione dell'aria.



CONNESSIONE DELL'ALIMENTAZIONE A GRAVITÀ

Sulle pistole a spruzzo con alimentazione a gravità il serbatoio si trova sopra la pistola. La forza di gravità spinge il fluido nella pistola.

Vantaggi: questo metodo consente rapidi cambiamenti di colore e convenienza per lavori piccoli o di ritocco. Le pistole a spruzzo con serbatoio superiore possono usare tutto il rivestimento – riducendo sprechi.

PRESSIONE DELL'ARIA

La pressione di atomizzazione deve essere impostata correttamente per consentire la caduta di pressione dell'aria fra il regolatore e la pistola a spruzzo.

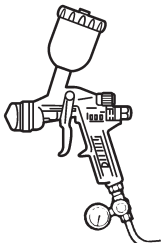
CON 60 PSI APPLICATI ALL'EROGAZIONE DELL'ARIA	
 5/16"	 1/4"
<p>RACCOMANDATO 48 PSI all'ingresso della pompa Un tubo flessibile da 25 piedi (7,6 metri) e 5/16" (0,8 cm) di diametro interno causa una caduta di pressione di 12 PSI fra l'erogazione dell'aria e la pistola. Per questo motivo, Binks raccomanda l'uso di un tubo da 5/16".</p>	<p>NON RACCOMANDATO Solamente 34 PSI all'ingresso della pompa Un tubo flessibile da 25 piedi (7,6 metri) e 1/4" (0,6 cm) di diametro interno causa una caduta di pressione di 26 PSI fra l'erogazione dell'aria e la pistola.</p>
	

Un estrattore di olio e acqua è un elemento importante.

Ottenere una finitura fine di vernice senza usare un buon estrattore di olio e acqua è praticamente impossibile.

Un regolatore/estrattore ha un doppio scopo. Elimina la formazione di bollicine e chiazze mantenendo l'aria libera da olio e acqua e consente un controllo della pressione preciso in corrispondenza della pistola.

Usare estrattori di olio e acqua e regolatori DeVilbiss. Rivolgersi al distributore di zona per i modelli.

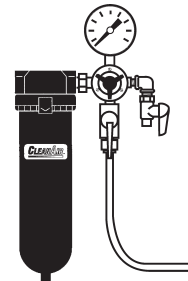

ISTRUZIONI PER L'INSTALLAZIONE

Per una massima efficienza di trasferimento, non usare più pressione di quanta necessaria per atomizzare il materiale da applicare.

NOTA

Quando si usa HVLP non superare le pressioni in ingresso elencate a pagina 7.

1. Collegare la pistola a una fonte d'aria pulita, priva di umidità e olio usando un tubo flessibile conduttivo di almeno 5/16" (0,8 cm) di diametro interno.

NOTA

A seconda della lunghezza del tubo, può essere necessario un tubo di diametro interno maggiore. Installare un manometro della pressione dell'aria sull'impugnatura della pistola. Vedere a pagina 7 le pressioni di servizio. Non usare più pressione di quanta necessaria per atomizzare il materiale da applicare. Una pressione eccessiva creerà una spruzzatura eccessiva riducendo l'efficienza di trasferimento.

NOTA

Se sono necessari accoppiamenti a connessione rapida, usare solamente connessioni rapide ad alto flusso approvate per l'uso HVLP. Altri tipi non faranno fluire sufficiente aria per il funzionamento corretto della pistola.

NOTA

Se si usa una valvola di regolazione dell'aria all'ingresso della pistola, usare la valvola di regolazione HAV-501.

2. **SOLAMENTE PER I MODELLI A SIFONE.** Collegare il gruppo del coperchio della coppa al connettore dell'ingresso del fluido. Posizionare la staffa della coppa ad angoli retti rispetto alla pistola.
3. **MODELLI CON ALIMENTAZIONE IN PRESSIONE.** Collegare il tubo flessibile di erogazione di fluido al connettore dell'ingresso del fluido.

NOTA

Prima di usare la pistola a spruzzo, lavarla con solvente per assicurarsi che i passaggi del fluido siano puliti.

USO

MODELLI CON SERBATOIO SUPERIORE

1. Mescolare il materiale di rivestimento seguendo le istruzioni del produttore e filtrare il materiale.
2. Riempire il serbatoio fino a non oltre 1,9 cm dal bordo superiore del serbatoio. **NON RIEMPIRE ECCESSIVAMENTE.**
3. Collegare al coperchio del serbatoio.
4. Ruotare la manopola di regolazione del fluido (24) in senso orario per prevenire il movimento dell'ago di fluido.

5. Ruotare il controllo della porta laterale (9) in senso antiorario per aprire completamente.
6. Regolare la pressione dell'aria ingresso, come necessario.
7. Ruotare in senso antiorario la manopola di regolazione del fluido fino a quando non si vede la filettatura iniziale.
8. Provare lo spruzzo. Se la finitura è troppo secca, ridurre il flusso d'aria abbassando la pressione di ingresso dell'aria.
9. Se la finitura è troppo bagnata, ridurre il flusso di fluido ruotando la manopola di regolazione del fluido (24) in senso orario. Se l'atomizzazione è troppo grossolana, aumentare la pressione dell'aria all'ingresso. Se è troppo fine, ridurre la pressione all'ingresso.
10. Le dimensioni del getto possono essere ridotte ruotando in senso orario il controllo della porta laterale (9).
11. Tenere la pistola perpendicolare alla superficie da spruzzare. Curvature o inclinazioni possono generare un rivestimento non uniforme.
12. La distanza di spruzzatura raccomandata è di 20 centimetri.
13. Spruzzare prima i bordi. Sovrapporre ciascuna spennellatura almeno del 75%. Spostare la pistola a una velocità costante.
14. Disattivare sempre l'erogazione d'aria e sfiatare la pressione quando non si usa la pistola.

MANUTENZIONE PREVENTIVA E PULIZIA

Per pulire il cappuccio dell'aria e l'ugello di fluido, strofinare la superficie esterna con una spazzola dura. Se è necessario pulire i fori del cappuccio, usare la paglia di una scopa o uno stuzzicadenti, se possibile. Se si usa uno strumento metallico o duro, fare molta attenzione ad evitare di graffiare o sbavare i fori con il rischio di deformare il getto.

Per pulire i passaggi di fluido, rimuovere il materiale in eccesso dalla pistola, quindi lavarla con una soluzione apposita. Strofinare la superficie esterna della pistola con un panno inumidito. Non immergere mai completamente in solventi o soluzioni detergenti poiché sono dannosi per i lubrificanti e riducono la vita della pistola a spruzzo.

NOTA

Se occorre sostituire l'ugello di fluido (7) o l'ago di fluido (22), sostituirli entrambi allo stesso tempo. L'uso di parti logorate può causare fuoriuscita di fluido. Cfr. pagina 4. Sostituire anche il giunto dell'ago allo stesso tempo. Ruotare l'ugello del fluido a una coppia di 230-240 inch-lbs. Non serrare eccessivamente.

ATTENZIONE

Per evitare di danneggiare l'ugello di fluido (7) o l'ago di fluido (22), assicurarsi di 1) tirare il grilletto e mantenerlo tirato mentre si serra o allenta l'ugello di fluido, o 2) rimuovere la manopola di regolazione del fluido (24) per sfiatare la pressione della molla contro il collare dell'ago.

SERBATOIO SUPERIORE. Versare il materiale in eccesso e pulire il serbatoio. Assicurarsi che il foro di sfiato nel coperchio sia aperto.

RIMOZIONE E INSTALLAZIONE

SMONTAGGIO E MONTAGGIO DELL'AGO E DELLA VALVOLA

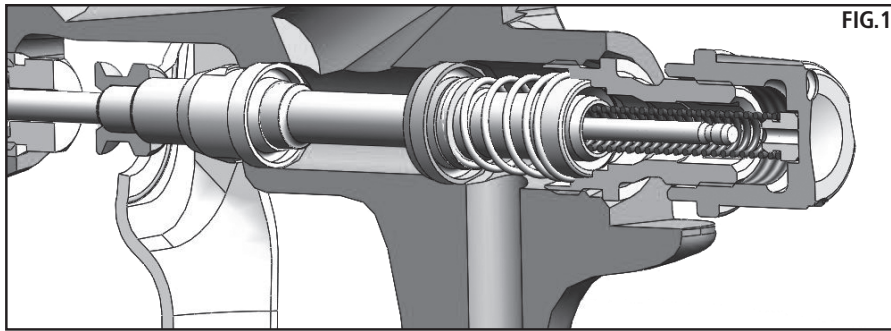

SMONTAGGIO

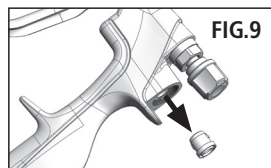
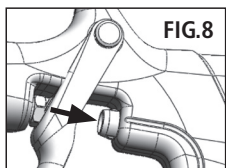
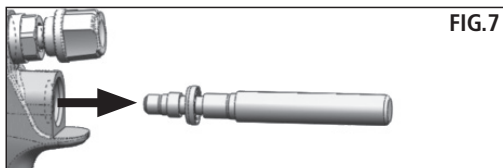
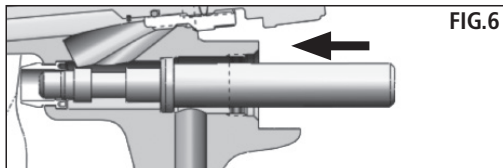
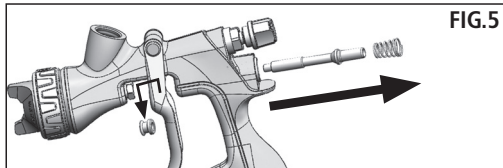
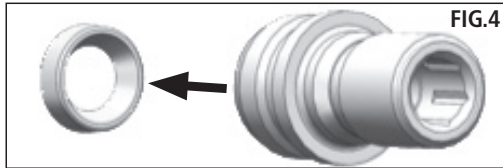
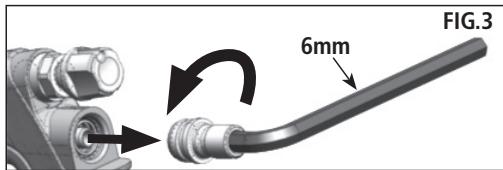
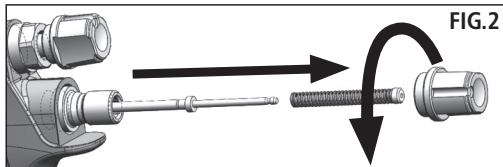

MONTAGGIO

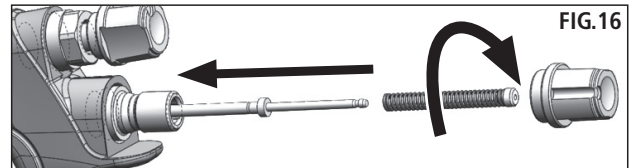
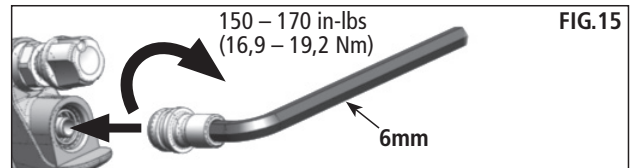
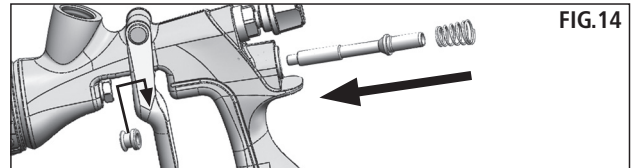
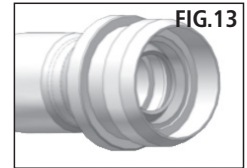
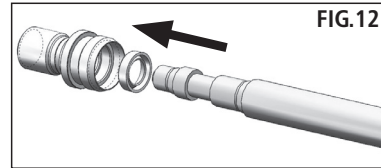
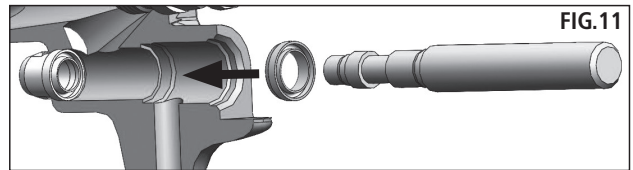
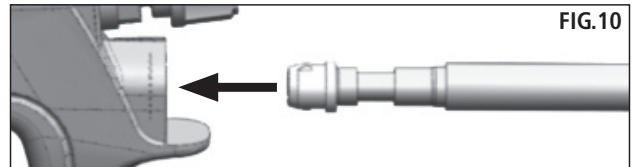

MANUTENZIONE – RIMOZIONE E INSTALLAZIONE DELL'UGELLO DI FLUIDO E DEL DEFLETTORE

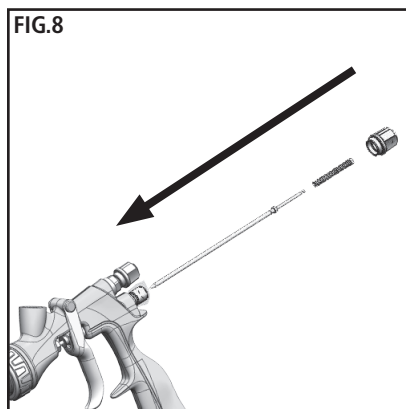
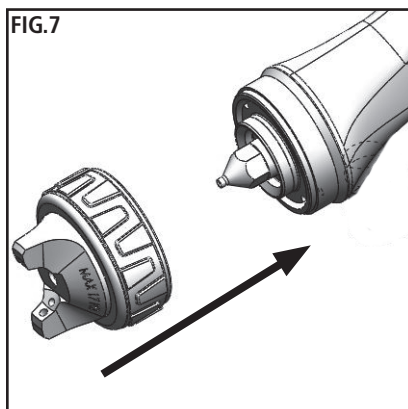
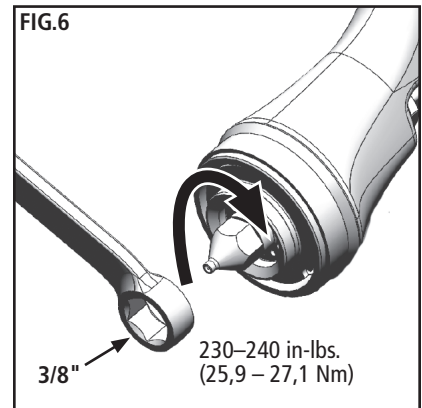
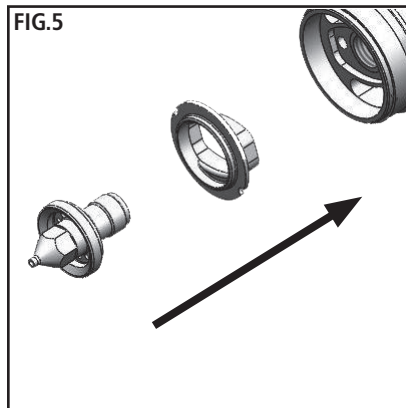
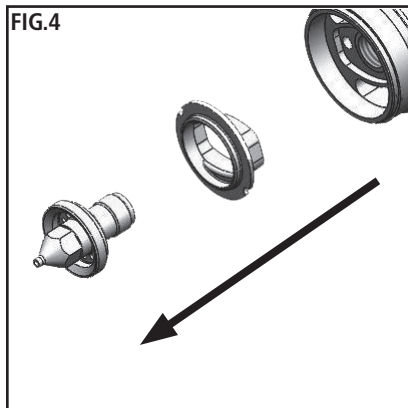
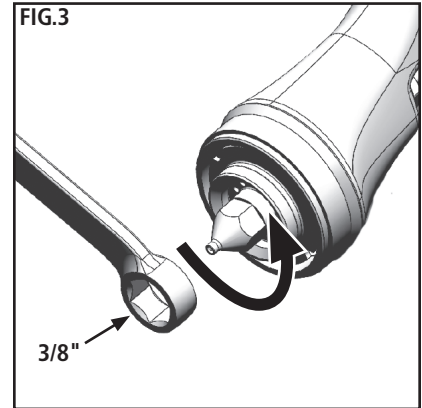
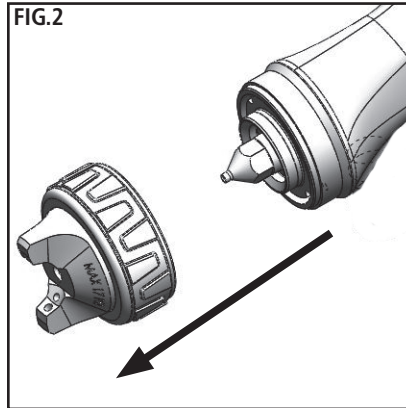
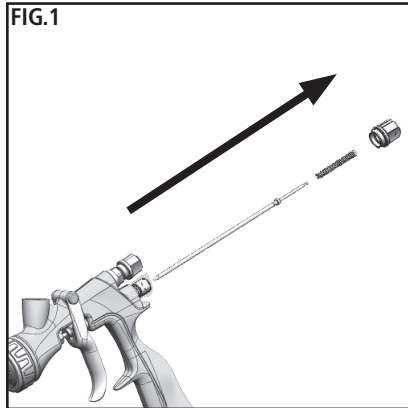

INSTALLAZIONE DEL CHIEDO INDICE CAPPUCCIO ARIA (54-6184) (CARATTERISTICA OPZIONALE – INDICIZZAZIONE AD INCREMENTI DI 90°)

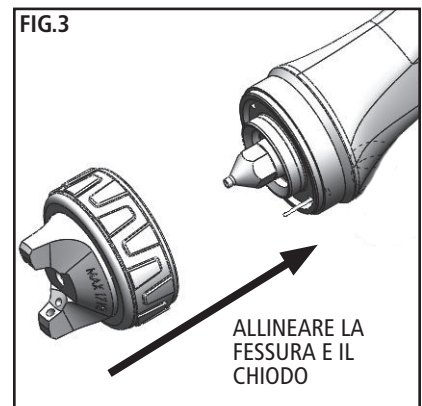
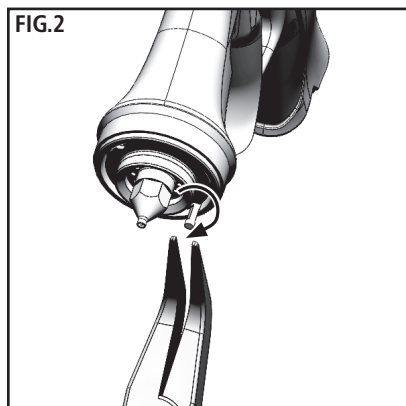
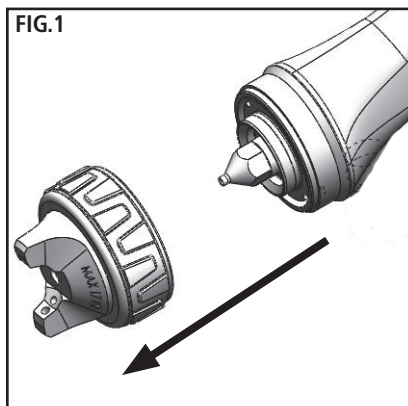



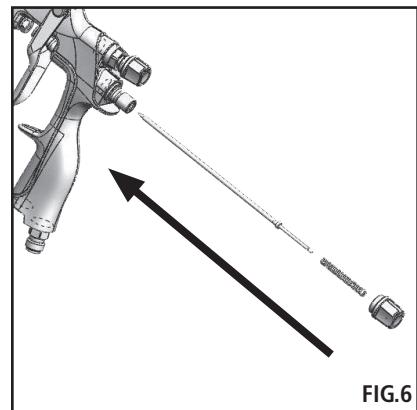
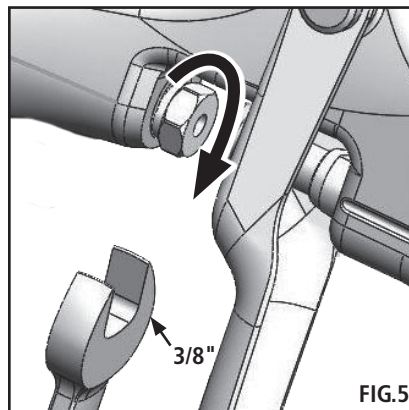
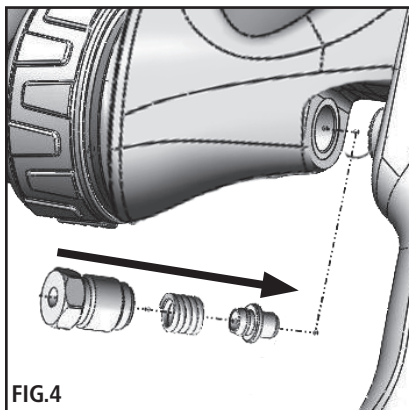
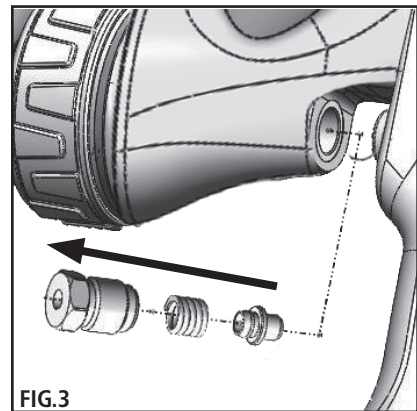
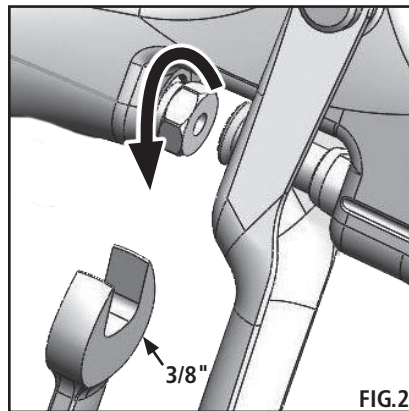
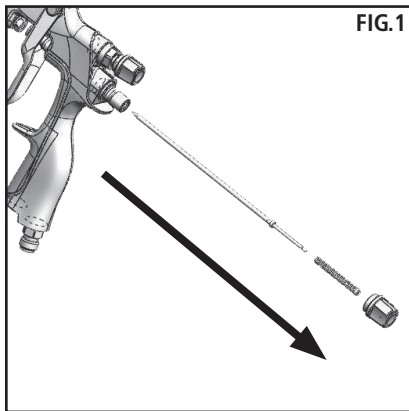

MANUTENZIONE – RIMOZIONE E INSTALLAZIONE DEL GIUNTO AGO

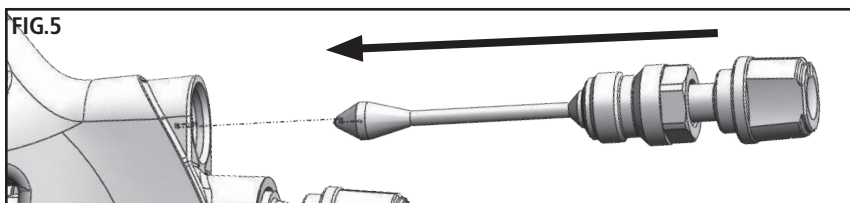
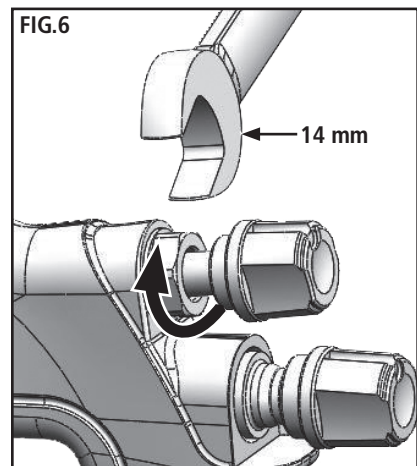
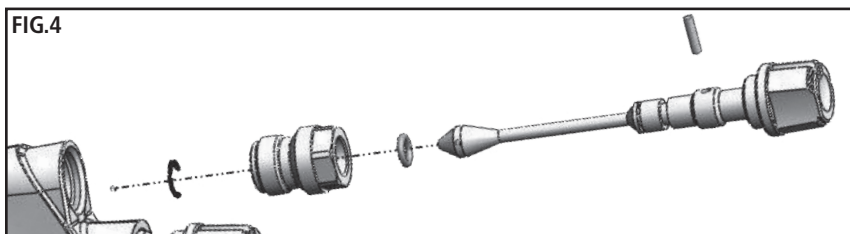
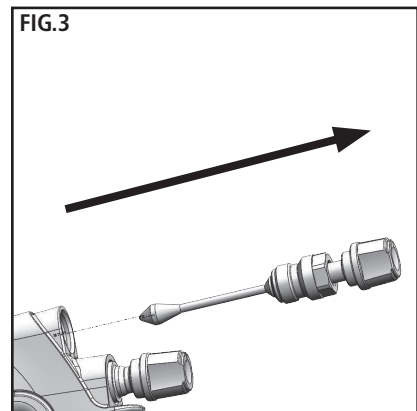
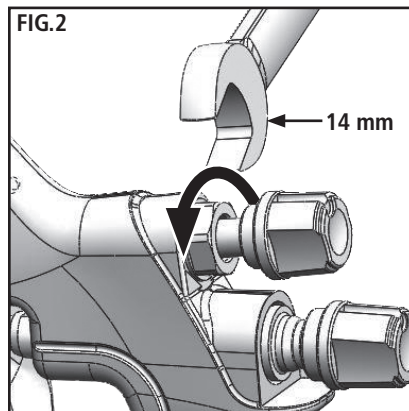
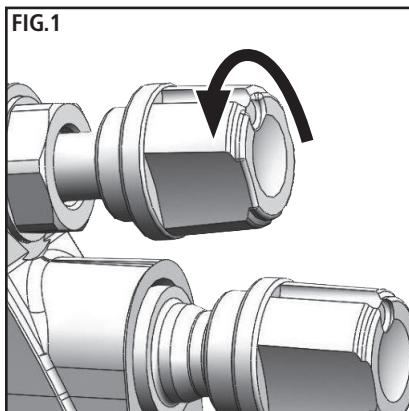

MANUTENZIONE – RIMOZIONE E INSTALLAZIONE DELLA PORTA LATERALE



RISOLUZIONE DEI PROBLEMI

CONDIZIONE	CAUSA	CORREZIONE
Getto pesante in alto o in basso 	Fori del corno tappati Ostruzione sulla parte superiore o inferiore della punta del fluido. Cappuccio e/o sede della punta sporchi.	Pulire. Alesare con una punta non metallica. Pulire. Pulire.
Getto pesante a destra o a sinistra 	Fori laterali del corno a sinistra o a destra tappati. Detriti sul lato sinistro o destro della punta del fluido.	Pulire. Alesare con una punta non metallica. Pulire.
Rimedi per getti pesanti in alto, in basso a destra e a sinistra. 1. Determinare se l'ostruzione è sul cappuccio dell'aria o sulla punta di fluido. Per farlo, fare una spruzzatura di prova. Quindi, ruotare il cappuccio di mezzo giro e spruzzare un altro getto. Se il difetto è invertito, l'ostruzione è sul cappuccio dell'aria. Pulire il cappuccio dell'aria come indicato in precedenza. 2. Se il difetto non è invertito, è sulla punta del fluido. Controllare se c'è una sbavatura sottile sul bordo della punta del fluido. Rimuovere con una carta smerigliata #600 bagnata o asciutta. 3. Controllare che non vi sia vernice secca all'interno dell'apertura, rimuoverla lavando con solvente.		
Getto pesante al centro 	Il fluido scorre troppo in alto per l'aria di atomizzazione. Il flusso di materiale supera la capacità del cappuccio dell'aria. La valvola di regolazione del distributore è impostata su un livello insufficiente. La pressione di atomizzazione è troppo bassa. Il materiale è troppo denso.	Equilibrare la pressione dell'aria e il flusso di fluido. Aumentare l'ampiezza del getto con la valvola di regolazione del distributore. Diluire o ridurre il flusso di fluido, Regolare, Aumentare la pressione. Consistenza da sottile a corretta.
Getto diviso 	La pressione dell'aria di atomizzazione è troppo elevata. Il flusso di fluido è troppo basso. La valvola di regolazione del distributore è impostata su un livello eccessivo.	Ridurre al trasformatore o alla pistola. Aumentare il flusso di fluido (aumentare la velocità di movimentazione della pistola) Regolare.
Spruzzo a scatti o vibrazioni 	*Punta/sede del fluido allentata o danneggiata. Livello di materiale troppo basso. Contenitore inclinato eccessivamente. Ostruzione nel passaggio di fluido. Dado di giunto dell'ago del fluido asciutto o allentato.	Serrare o sostituire. Riempire. Tenere verticalmente. Lavare dal retro con solvente. Lubrificare o serrare.
Impossibile ottenere una spruzzatura circolare	Vite di regolazione del distributore non posizionata correttamente. Anello di fermo del cappuccio dell'aria allentato.	Pulire o sostituire. Serrare.
Non spruzza	Nessuna pressione dell'aria alla pistola. Vite di regolazione dell'ago di fluido non aperta sufficientemente. Fluido troppo pesante per l'alimentazione a gravità.	Controllare l'aria e i tubi dell'aria, soffiare sui passaggi dell'aria della pistola. Aprire la vite di regolazione dell'ago di fluido. Diluire il materiale e/o usare una punta più grande.
Bolle di vernice nella coppa	Punta di fluido serrata eccessivamente.	Serrare la punta.
Fuoriuscita o gocce dal coperchio della coppa	Coperchio della coppa allentato. Filettature sporche sulla coppa o sul coperchio. Coppa o coperchio incrinato.	Serrare il coperchio, Pulire Sostituire la coppa e il coperchio.

*Problemi più comuni.

RISOLUZIONE DEI PROBLEMI

CONDIZIONE	CAUSA	CORREZIONE
Getto non impregnato a sufficienza	Flusso di materiale inadeguato. Bassa pressione dell'aria di atomizzazione.	Tirare indietro la vite di regolazione del fluido fino alla prima filettatura, o usare una punta più grande. Aumentare la pressione dell'aria e riequilibrare la pistola.
Spruzzatura eccessiva	Eccessiva pressione dell'aria di atomizzazione. Pistola troppo lontana dalla superficie di lavoro. Spennellatura inadeguata (curve, movimento della pistola troppo veloce).	Ridurre la pressione Modificare la distanza. Spostarsi a un ritmo moderato, parallelamente alla superficie di lavoro.
Velo eccessivo	Troppo diluente o diluente che si asciuga troppo in fretta. Troppa atomizzazione (pressione dell'aria).	Rimescolare correttamente. Ridurre la pressione dell'aria.
Spruzzatura secca	Pressione dell'aria troppo elevata. Punta della pistola troppo lontana dalla superficie di lavoro. Movimento della pistola troppo veloce. Pistola non regolata correttamente.	Ridurre la pressione dell'aria. Modificare la distanza. Rallentare. Regolare.
Fuoriuscita di fluido dal dado del giunto	Dado del giunto allentato. Giunto logorato o asciutto.	Serrare, non bloccare l'ago. Sostituire o lubrificare.
Fuoriuscita di fluido o gocce dalla parte frontale della pistola.	Dado del giunto troppo serrato. Giunto asciutto. Punta o ago del fluido logorato o danneggiato. Materia estranea nella punta. Molla dell'ago di fluido rotta. Ago o punta delle dimensioni errate.	Regolare Lubrificare. Sostituire la punta e l'ago. Pulire. Sostituire. Sostituire.
Gocce o fuoriuscita di fluido dal fondo della coppa.	Coppa allentata sulla pistola. Guarnizione della coppa logorata o nessuna guarnizione sotto la coppa. Filettature della coppa sporche.	Serrare. Sostituire la guarnizione della coppa. Pulire.
Colature e incurvature	Eccessivo flusso di materiale. Materiale troppo diluito. Pistola inclinata ad un angolo, o movimento della pistola troppo lento.	Regolare la pistola o ridurre il flusso di fluido. Mescolare correttamente o applicare strati leggeri. Tenere la pistola a un angolo retto per lavorare e usare la tecnica appropriata.
Finitura leggera, sabbiosa a grana grossa che si asciuga prima di uscire.	Pistola troppo lontana dalla superficie di lavoro. Eccessiva pressione dell'aria. Diluente usato non idoneo.	Controllare la distanza. In genere circa 20 cm. Ridurre la pressione dell'aria e controllare il getto. Seguire le istruzioni del produttore per la miscelatura.
Finitura spessa, increspata a "buccia d'arancia"	Pistola troppo vicina alla superficie. Troppo materiale atomizzato a grana grossa. Pressione dell'aria troppo bassa. Diluente usato non idoneo. Materiale non mescolato correttamente. Superficie ruvida, grassa, sporca.	Controllare la distanza. In genere circa 20 cm. Seguire le istruzioni del produttore per la miscelatura. Aumentare la pressione dell'aria o ridurre il flusso di fluido. Seguire le istruzioni del produttore per la miscelatura. Seguire le istruzioni del produttore per la miscelatura. Pulire bene e preparare.

ACCESSORI

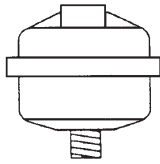
HAF-507-K12
Whirlwind™
Filtro dell'aria in linea
Kit di 12

Elimina acqua, grasso e detriti dal tubo dell'aria.

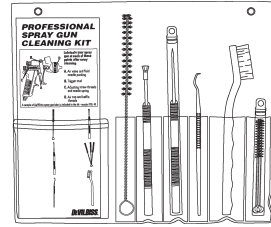
192212 Kit di pulizia della pistola a spruzzo professionale

Contiene sei attrezzi di precisione concepiti per pulire efficacemente tutte le pistole a spruzzo DeVilbiss, Binks, Finishline e di altre marche.

6-429 Binks Gunners Mate Lube
(Venti flaconi da 59 ml)

Compatibile con tutti i materiali di vernice, non contiene silicone o distillati di petrolio che possono contaminare la vernice. MSDS disponibile a richiesta.

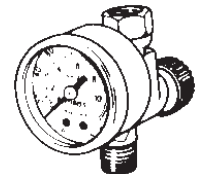
HAV-500 OR HAV-501
Valvola di regolazione
(HAV-501 IN FIGURA)

HAV-500 non dispone di manometro. Usare per controllare l'utilizzo d'aria alla pistola.

Millennium 3000
Maschera respiratore per vernice a doppia cartuccia

Omologata NIOSH, per protezione delle vie respiratorie in atmosfere non immediatamente dannose per la vita.

Piccola	Media	Grande
40-141	40-128	40-143

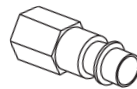
Connettori rapidi per pistole HVLP (Aria)
 Tipo alto flusso

HC-4419 Stelo
1/4" NPT(F)
Punta pistola

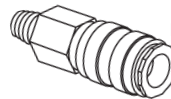

HC-4719 accoppiatore
1/4" NPT(F)
Punta tubo flessibile

Salviette detergenti 29-3100 Scrubs®

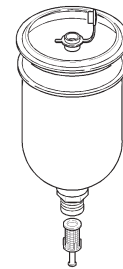

Le Scrubs® sono salviette bagnate per verniciatori, carrozzieri e meccanici che possono essere portate ovunque e che non richiedono acqua.

Serbatoio superiore in alluminio da 1,1 litro

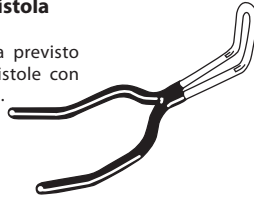
192219
Supporto pistola

Supporto pistola previsto per sostenere pistole con serbatoi superiori.

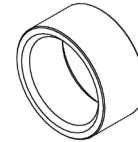
KGP-13-K5
Guarnizione serbatoio

Guarnizione dell'ingresso di fluido necessario per l'uso per serbatoi metallici.

54-6197
Arresto di regolazione ago

Accessori DeKups® per coppe a sifone

DPC-60-K10
9oz Universal
x10

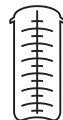

DPC-59-K10
24oz Universal
x10



DPC-61-K10
34oz Universal
x10

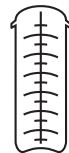

125 µm
DPC-42-K24
x24



125 µm
DPC-65-K24
x24



200 µm
DPC-66-K24
x24



200 µm
DPC-67-K24
x24



DPC-6-K10
x10



DPC-22-K24
x24



DPC-44

DPC-31



DPC-607
x2



DPC-606
x2



DPC-608
x2

CARCASSE



9 FL
265 mL
DPC-602
x32



24 FL
710 mL
DPC-601
x32



34 FL
1000 mL
DPC-600
x32

RIVESTIMENTI

GARANZIA

I prodotti Binks sono coperti dalla garanzia limitata per materiali e lavorazione di un anno di Carlisle Fluid Technologies. L'uso di qualsiasi parte o accessorio, che non sia Carlisle Fluid Technologies, rende nulle tutte le garanzie. Per informazioni specifiche sulla garanzia si prega di rivolgersi alla sede Carlisle Fluid Technologies più vicina fra quelle elencate qui sotto.

Carlisle Fluid Technologies si riserva il diritto di modificare le specifiche tecniche dell'apparecchio senza preavviso. DeVilbiss®, Ransburg®, MS®, BGK®, e Binks® sono marchi depositati di Carlisle Fluid Technologies, Inc. ©2017 Carlisle Fluid Technologies, Inc. Tutti i diritti riservati.



Binks fa parte di Carlisle Fluid Technologies, leader globale nelle tecnologie di finitura. Per assistenza tecnica o per individuare un distributore autorizzato, rivolgersi a una delle nostre sedi internazionali di vendita e assistenza.

USA/Canada

info@carlisleleft.com
Tel: 1-888-992-4657
Fax: 1-888-246-5732

Messico

ventas@carlisleleft.com.mx
Tel: 011 52 55 5321 2300
Fax: 011 52 55 5310 4790

Brasile

vendas@carlisleleft.com.br
Tel: +55 11 5641 2776
Fax: 55 11 5641 1256

Regno Unito

info@carlisleleft.eu
Tel: +44 (0)1202 571 111
Fax: +44 (0)1202 573 488

Francia

info@carlisleleft.eu
Tel: +33(0)475 75 27 00
Fax: +33(0)475 75 27 59

Germania

info@carlisleleft.eu
Tel: +49 (0) 6074 403 1
Fax: +49 (0) 6074 403 281

Cina

mkt@carlisleleft.com.cn
Tel: +8621-3373 0108
Fax: +8621-3373 0308

Giappone

overseas-sales@carlisleleft.co.jp
Tel: 081 45 785 6421
Fax: 081 45 785 6517

Australia

sales@carlisleleft.com.au
Tel: +61 (0) 2 8525 7555
Fax: +61 (0) 2 8525 7575

Per le ultime informazioni sui nostri prodotti, visitare il sito www.carlisleleft.com.

