

DX200-3 3:1

Stainless Steel Diaphragm Pump

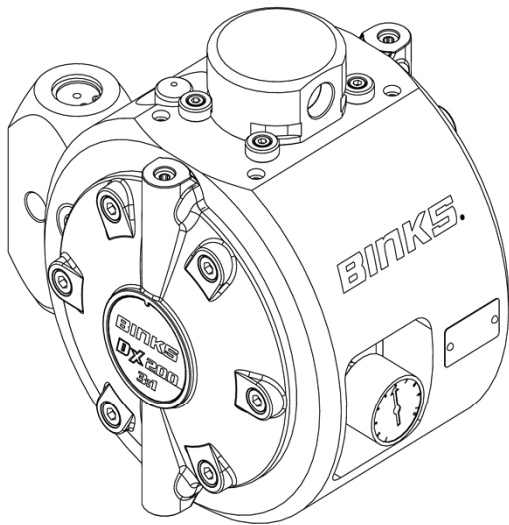

DX200-3SN

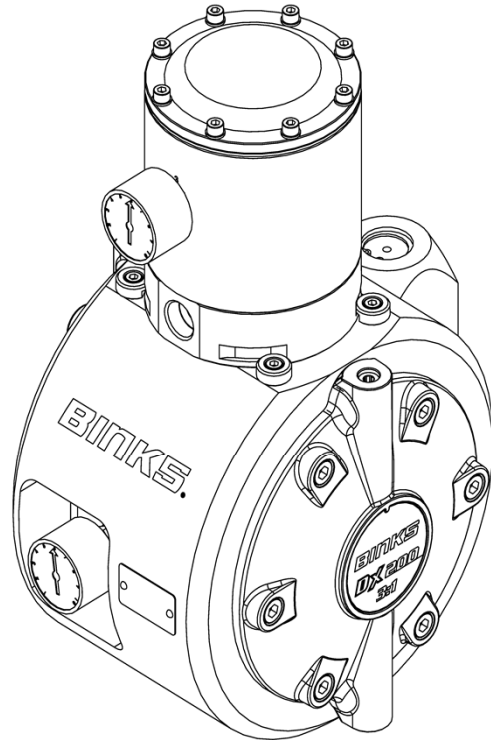

DX200-3SP

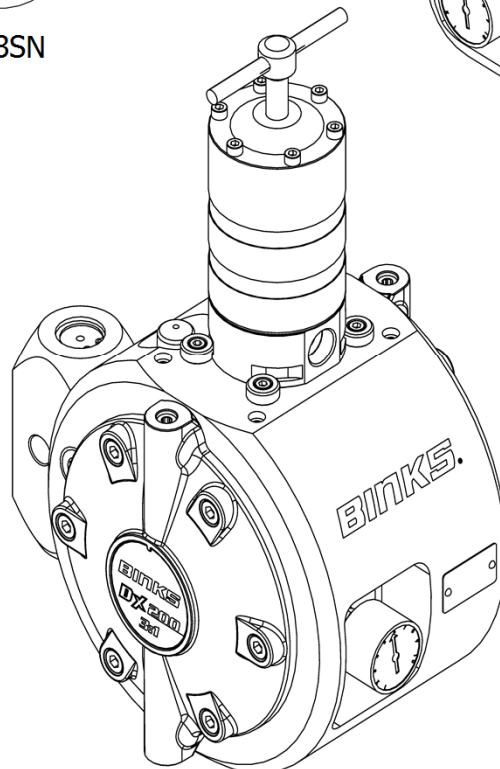

DX200-3SM

Product Description / Object of Declaration: Diaphragm Pumps - DX70, DX200, DX200-3 Bare pump and packages

EN

This Product is designed for use with: Solvent and Water based Materials

Suitable for use in hazardous area: Zone 1

Protection Level: II 2 G c X IIB T4

Notified body details and role: TRAC Global Ltd (0891)
Lodging of Technical file

This Declaration of conformity / incorporation is issued under the sole responsibility of the manufacturer: Finishing Brands UK Ltd,
Ringwood Road,
Bournemouth, BH11 9LH. UK

EU Declaration of Conformity



The object of the declaration described above is in conformity with the relevant Union harmonisation legislation:

Machinery Directive 2006/42/EC

ATEX Directive 2014/34/EU

by complying with the following statutory documents and harmonized standards:

EN ISO 12100:2010 Safety of Machinery - General Principles for Design

EN 12621:+A1:2010 Machinery for the supply and circulation of coating materials under pressure - Safety requirements

EN1127-1:2011 Explosive atmospheres - Explosion prevention - Basic concepts

EN 13463-1:2009 Non electrical equipment for use in potentially explosive atmospheres - Basic methods and requirements



EN 13463-5:2011 Non electrical equipment for use in potentially explosive atmospheres - Protection by constructional safety

Providing all conditions of safe use / installation stated within the product manuals have been complied with and also installed in accordance with any applicable local codes of practice.

Signed for and on behalf of Finishing Brands
UK Ltd:

D Smith
20/4/16

Director of Sales (EMEA)
Bournemouth, BH11 9LH, UK

 WARNING	 CAUTION	NOTE
Hazards or unsafe practices which could result in severe personal injury, death or substantial property damage.	Hazards or unsafe practices which could result in minor personal injury, product or property damage	Important installation, operation or maintenance information.

 **WARNING**

Read the following warnings before using this equipment.



READ THE MANUAL. Before operating finishing equipment, read and understand all safety, operation and maintenance information provided in the operation manual.



AUTOMATIC EQUIPMENT. Automatic equipment may start suddenly without warning.



WEAR SAFETY GLASSES. Failure to wear safety glasses with side shields could result in serious eye injury or blindness.

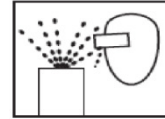

PROJECTILE HAZARD. You may be injured by venting liquids or gases that are released under pressure, or flying debris.



DE-ENERGIZE, DE-PRESSURISE, DISCONNECT AND LOCK OUT ALL POWER SOURCES DURING MAINTENANCE. Failure to de-energize, disconnect and lock out all power supplies before performing equipment maintenance could cause serious injury or death.



KNOW WHERE AND HOW TO SHUT OFF THE EQUIPMENT IN CASE OF AN EMERGENCY.



NOISE LEVELS. The A-weighted sound level of pumping and spray equipment may exceed 85 dB(A) depending on equipment settings. Actual noise levels are available on request. It is recommended that ear protection is worn at all times while equipment is in use.



PRESSURE RELIEF PROCEDURE. Always follow the pressure relief procedure in the equipment instruction manual.



INSPECT THE EQUIPMENT DAILY. Inspect the equipment for worn or broken parts on a daily basis. Do not operate the equipment if you are uncertain about its condition.

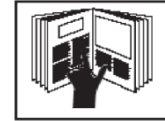

OPERATOR TRAINING. All personnel must be trained before operating finishing equipment.



EQUIPMENT MISUSE HAZARD. Equipment misuse can cause the equipment to rupture, malfunction or start unexpectedly and result in serious injury.



PACEMAKER WARNING. You are in the presence of magnetic fields which may interfere with the operation of certain pacemakers.



HIGH PRESSURE CONSIDERATION. High pressure can cause serious injury. Relieve all pressure before servicing. Spray from the gun, hose leaks or ruptured components can inject fluid into your body and cause extremely serious injury.



KEEP EQUIPMENT GUARDS IN PLACE. Do not operate the equipment if the safety devices have been removed.



STATIC CHARGE. Fluid may develop a static charge that must be dissipated through proper grounding of the equipment, objects to be sprayed and all other electrically conductive objects in the dispensing area. Improper grounding or sparks can cause a hazardous condition and result in fire, explosion or electric shock and other serious injury.



NEVER MODIFY THE EQUIPMENT. Do not modify the equipment unless the manufacturer provides written approval.



PROP 65 WARNING. WARNING: This product contains chemicals known to the state of California to cause cancer and birth defects or other reproductive harm.



PINCH POINT HAZARD. Moving parts can crush and cut. Pinch points are any areas where there are moving parts.

IT IS THE RESPONSIBILITY OF THE EMPLOYER TO PROVIDE THIS INFORMATION TO THE OPERATOR OF THE EQUIPMENT.

Specification

	Ratio:	3:1	
	Maximum air inlet pressure:	7 Bar [100 PSI]	
	Maximum fluid pressure:	21 Bar [305 PSI]	
	Displacement per cycle:	0.14 Litres [0.037 US Gall]	
	Output @ 60 cycles / min:	8.4 Litres/min [2.2 US Gall/min]	
	Maximum Recommended Continuous Cycle Rate (cycles / min):	20	
	Maximum Recommended Intermittent Cycle Rate (cycles / min):	40	
A	Fluid inlet connection:	1/2" BSPP Female	
B	Fluid outlet connection:	1/2" BSPP Female	
C	Air inlet connection:	1/4" Universal (BSPP/ NPSM) Female	
	Maximum dry/wet Lift:	6.9m [22.6ft] / 8.7m [28.5ft]	
	Air volume / cycle @ 6.9 Bar/100psi:	5.0L [0.18 SCFM]	
	Air flow @ 10 cycles / min 6.9 bar / 100psi:	47.8L [1.69 SCFM]	
	Air flow @ 30 cycles / min 6.9 bar / 100psi:	156.9L [5.54 SCFM]	
	Recommended air quality ISO 8573.1 Class 3.3.2 #:	Dirt:	5 µm
		Water:	-20°C@7bar [940ppm]
		Oil:	0.1mg/m ³
		Non Lubricated	
	Noise Level @ 40 cycles/min & 7 bar [100 psi]	79.8 dBA Leq	
E	Earth connection resistance:	<1Ω	
	Weight:	DX200-3SN	17.9 Kg [39.4lb's]
		DX200-3SM	19.1 Kg [42.1lb's]
		DX200-3SP	21.1 Kg [46.5lb's]
	Temperature range	0 - 40 °C [32 - 104 °F]	

Installation

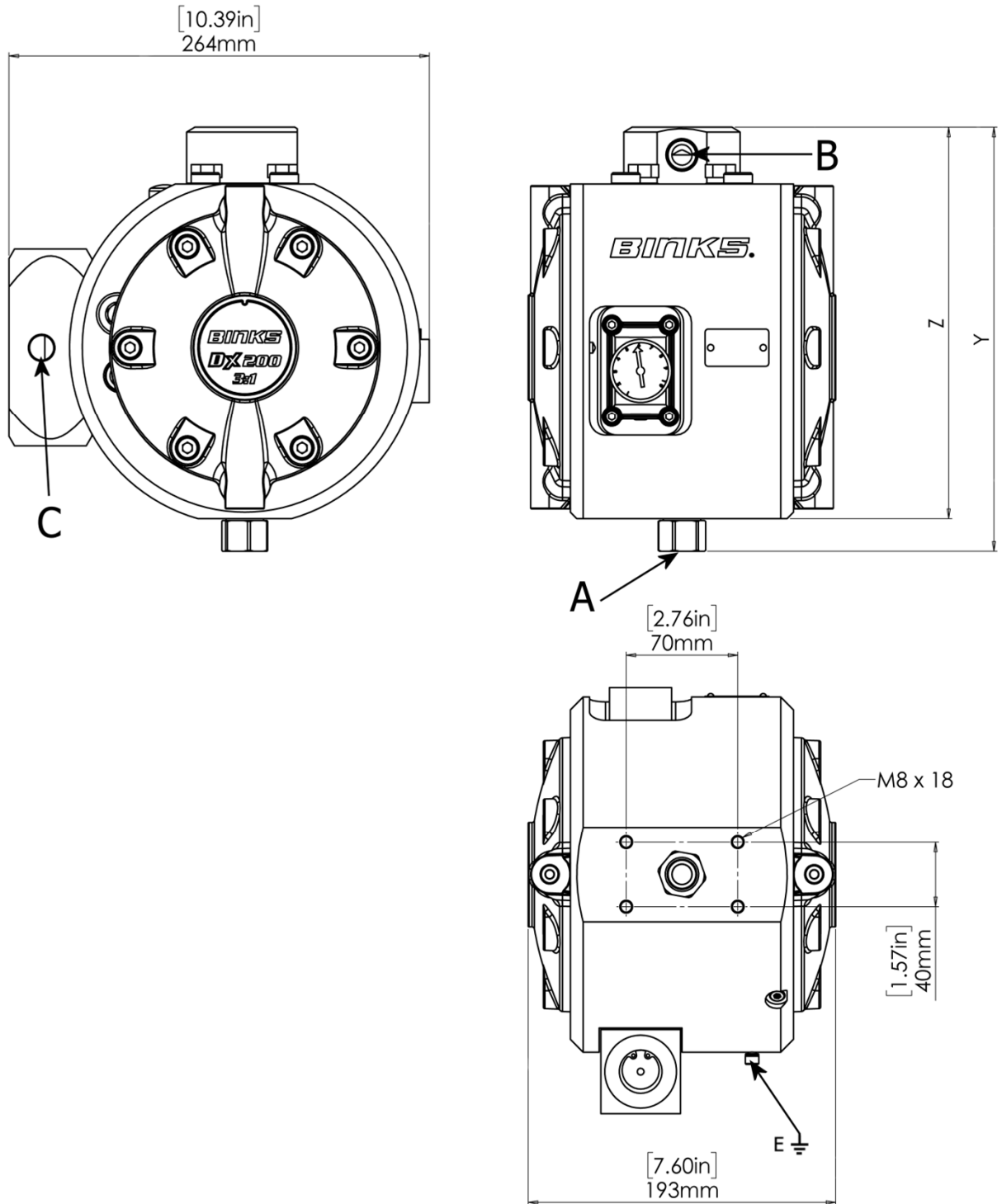

	Dimension	
	Y	Z
DX200-3SN	262mm	242mm
DX200-3SM	410mm	390mm
DX200-3SP	344mm	324mm

Prior To Use

This product should be flushed with a suitable compatible solvent prior to use.

Mount the pump securely and position the pump at a convenient height to allow for maintenance.

Attach flexible hoses to all connections. Connect a regulated air supply to the air connection.

Set the pump speed to a slow cycle rate and prime the pump to remove any air before increasing pressure.

End caps are to be re-torqued to 14Nm prior to use. To be checked again after 24 hours of use.

ATEX special conditions for safe use:

Pump Earthing

The pump must be earthed at all times. A resistance $<1\Omega$ when measuring with an ohm-meter at the earth point

Earth connection, Binks Part No. 0114-011798

Paint section materials of construction

Item	Material
Pump body inserts	Stainless steel
End cap	Stainless steel
Diaphragms	PTFE
Seals	FKM/PE
Valve ball & spring	Stainless steel
End cap plugs	Stainless steel
Ball Cage	(Acetal) POM
Fluid regulator & pulsation chamber	Stainless steel/PTFE/PE/FKM

Spare parts

Item	Part No.	Description
1	DXK-284	Check valve seal kit x4
2	DXK-285	Check valve kit x4
3	DXK-258	Diaphragm kit x2
4	DXK-206	Caps & screws x2
5	DXK-18	Cover, seal & screws
6	DXK-25	Gasket x4
7	DXK-216	Air valve kit
8	DXK-275	End cap x1 End cap x1
9	DXK-207	End cap bolts x12
10	0114-019209	Reducing Bush
11	GA-382-P	Gauge
12	DXK-286	End cap seal kit x4

Spare Parts

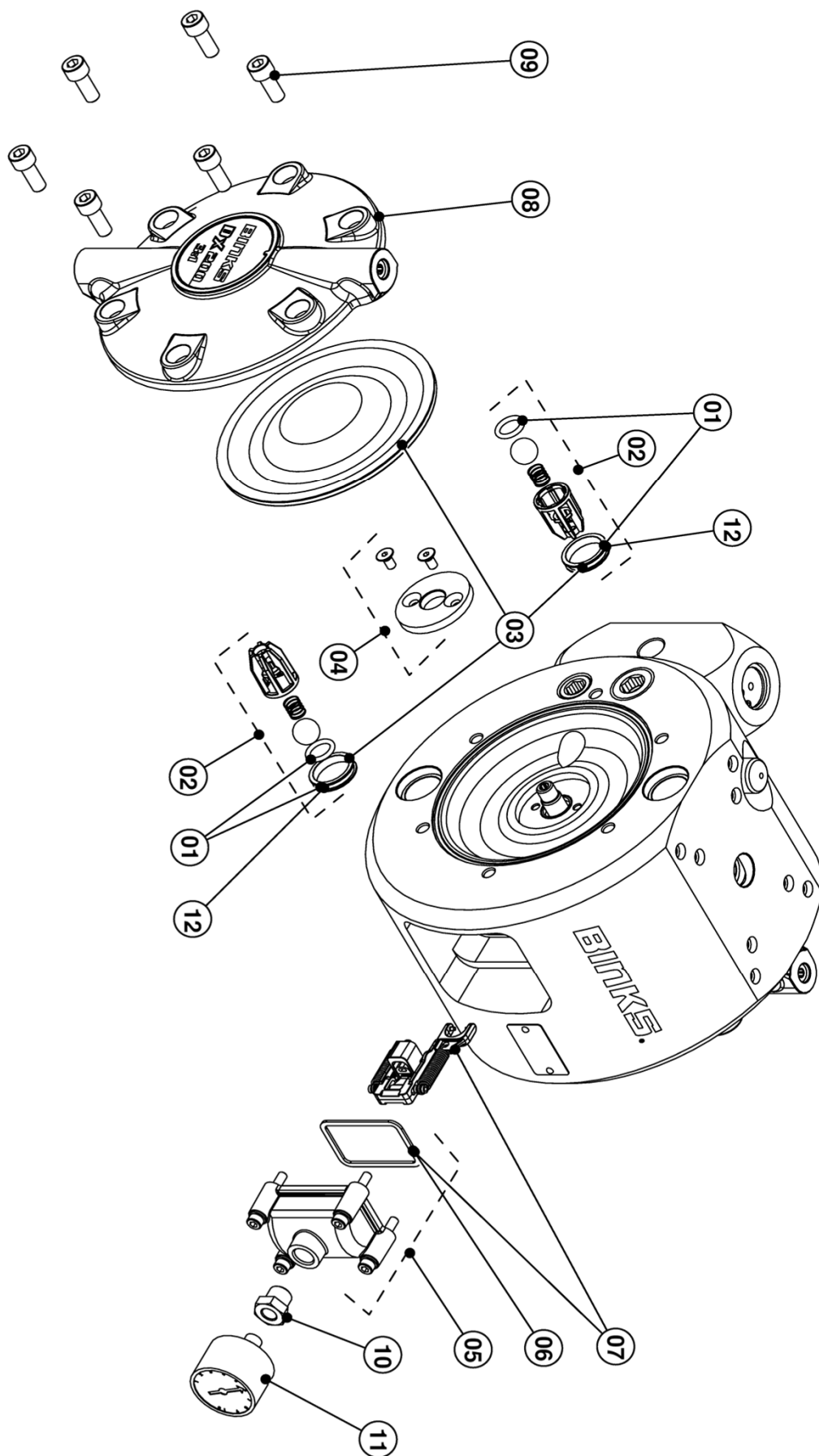

Spare Parts

Item	Part No.	Description
13	DXK-207	End cap bolts x12
14	DXK-275	End cap - Includes seals
15	DXK-258	Diaphragm kit x2
16	DXK-236	Cylinder cap - Includes seals x3
17	DXK-263	Piston & shaft assembly - Includes seals
18	DXK-266	Shaft & seal kit
19	DXK-261	Shaft seal x1
20	DXK-237	Seal x2
21	DXK-264	Piston assembly - Includes seals
22	DXK-265	Piston seal x1
23	DXK-285	Check valve kit x4
24	DXK-284	Check valve seal kit x4
25	DXK-232	1/2" Female inlet connector kit, with seals
26	DXK-273	Stainless steel inserts
27	DXK-229	Inlet/outlet seal x4
28	DXK-230	Insert seal x4
29	DXK-238	Pin - Includes seal
30	DXK-239	Seal x1
31	DXK-240	SILENCER
32	DXK-241	Gasket x2
33	DXK-242	Bolts x4
34	DXK-243	Air valve kit
	DXK-244	Air Valve rebuild kit

Spare parts

Item	Part No.	Description
35	DXK-268	Adjusting screw
36	DXK-269	Screw x6
37	DXK-270	Spring pad
38	DXK-271	Spring
39	DXK-272	Diaphragm assembly
40	DXK-214	Regulator Insert
41	DXK-215	Seal x4
42	DXK-229	Inlet/outlet seal x4
43	DXK-230	Insert seal x4
44	DXK-231	Non regulated assembly
45	DXK-274	Manual regulator assembly
46	DXK-282	Retainer kit x4
47	DXA-SC31P	Active surge chamber
48	DXK-259	Regulator body

Spare parts

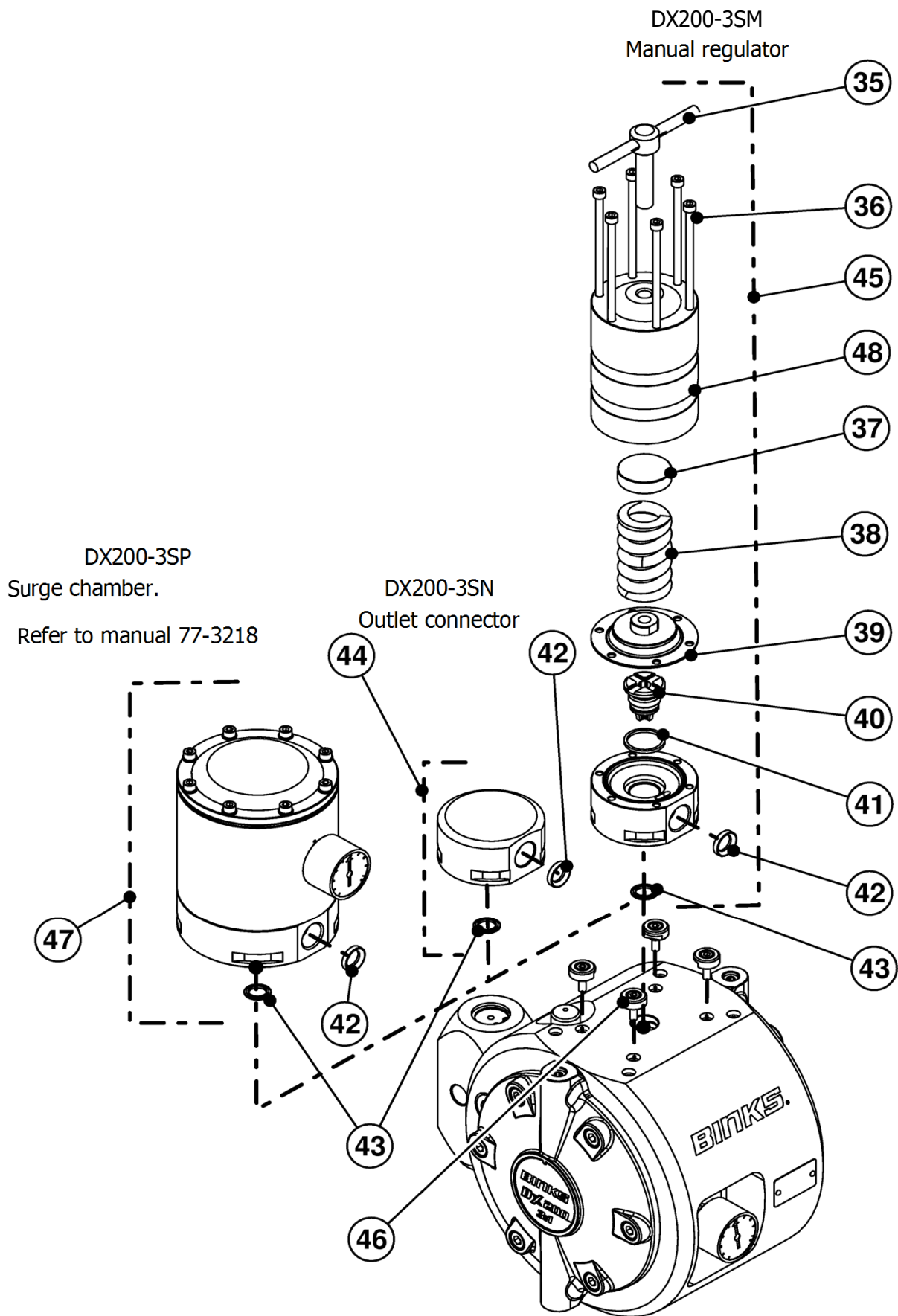

ACCESSORIES

Item	Part No.	Description
1	DXK-232	1/2" Female inlet connector kit, with seals
2	DXK-233	1/2" Male inlet connector kit, with seals
3	DXK-234	3/4" Female inlet connector kit, with seals
4	DXK-235	1/2" - 3/8" Male inlet connector kit, with seals
5	DXK-230	Seal x4
6	DXK-229	Seal x4
7	DXK-221	Seal x4

Inlet Connectors

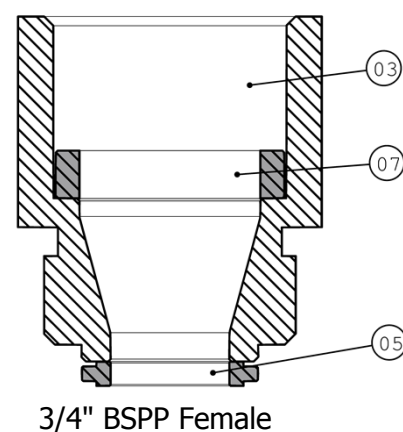
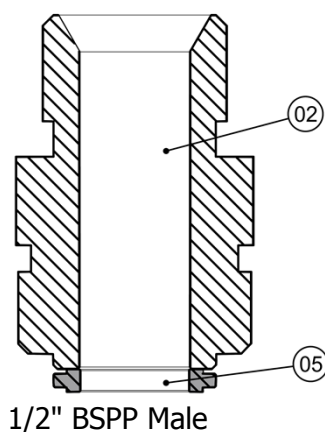
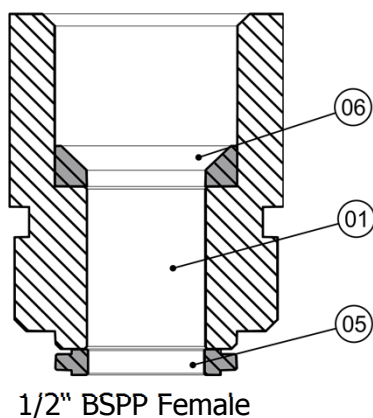

Outlet Adaptor

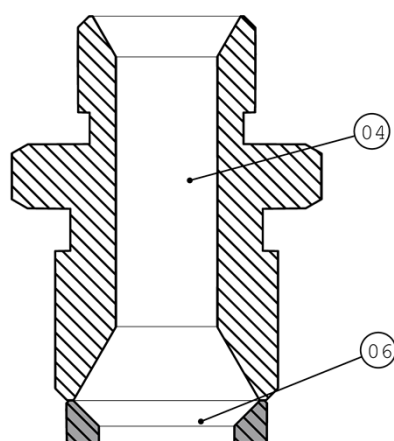

Maintenance

Key - Maintenance symbols



= Order for dis-assembly
(reverse for assembly)



= Grease (AGMD-010)

Fig. 1

= refer to figure

13MM

= Spanner or socket size

8 Nm

= Torque required

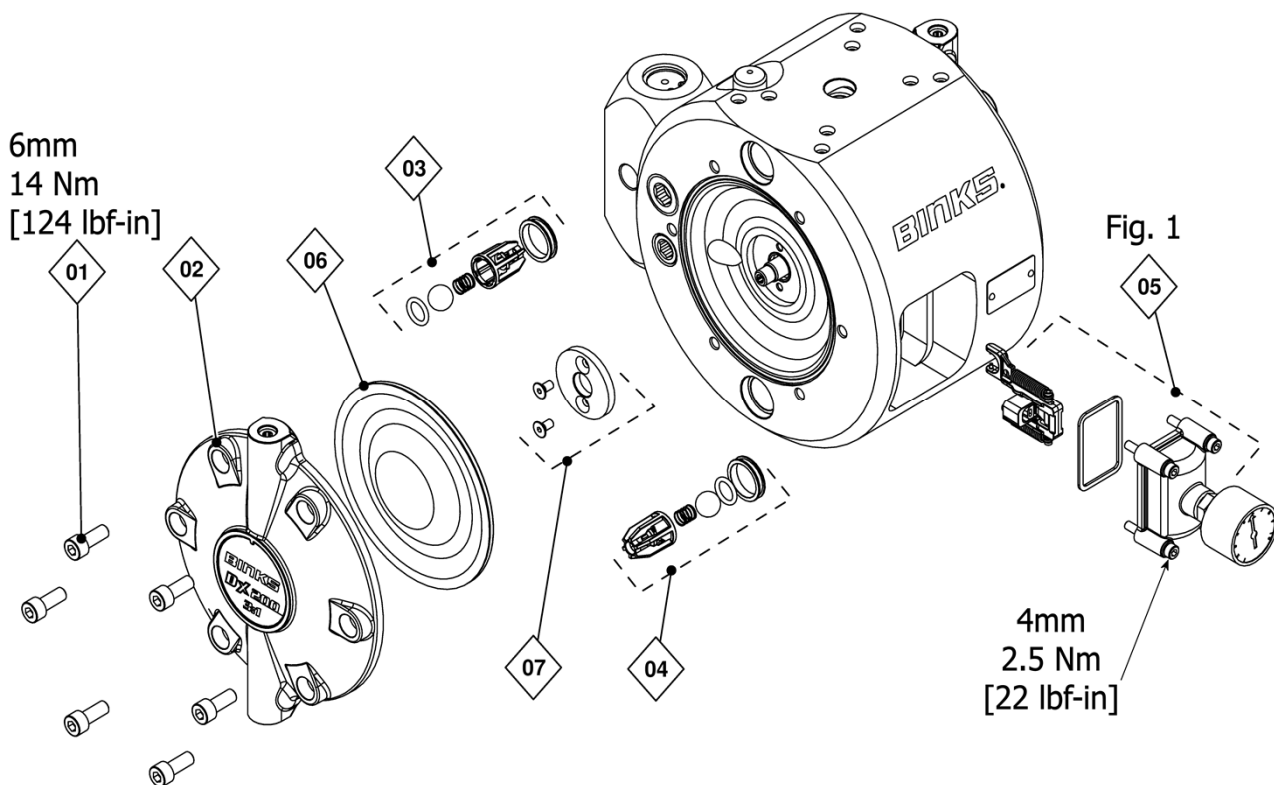

Non-Piston side

Maintenance

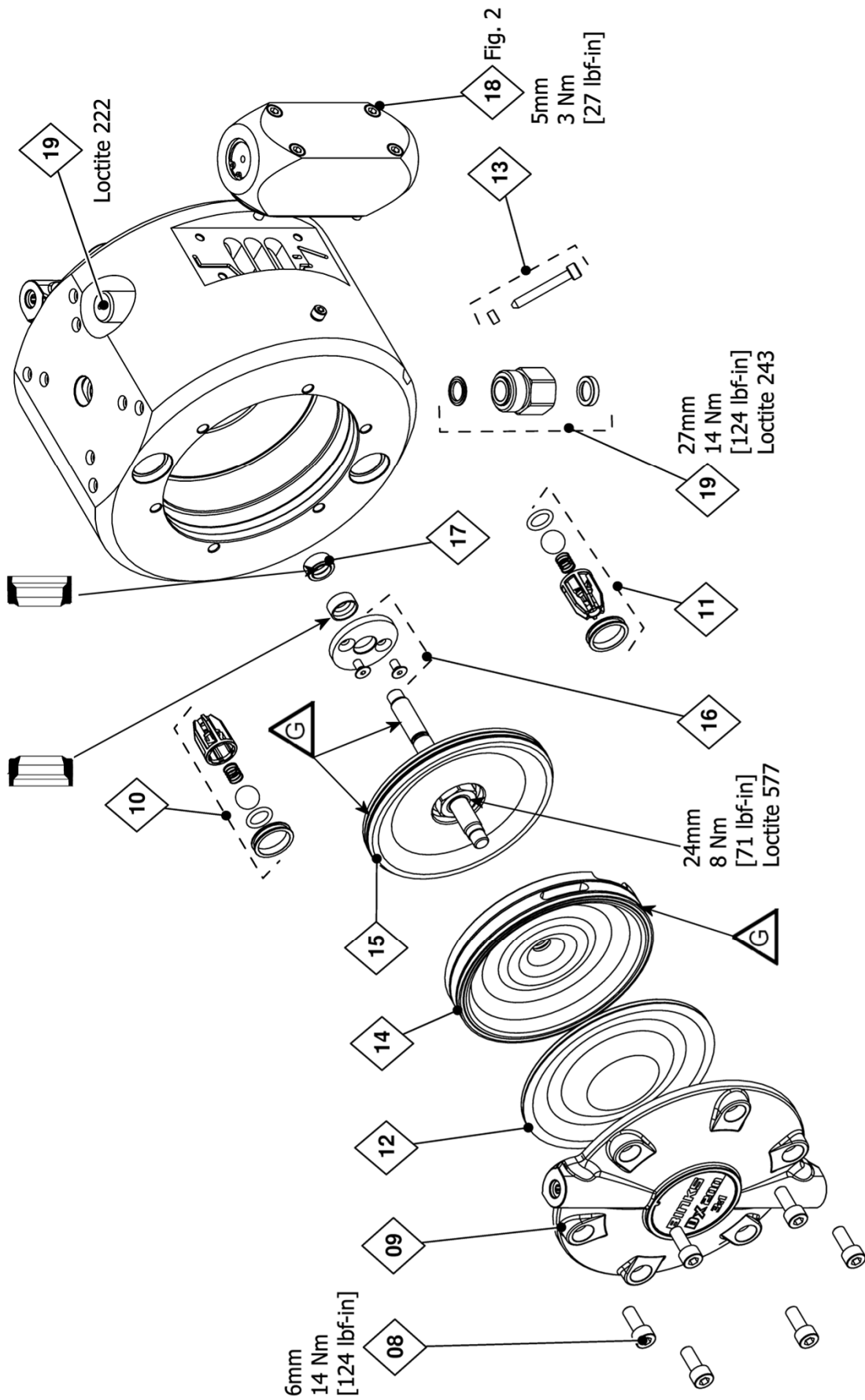

Piston side

Maintenance

Figure 1

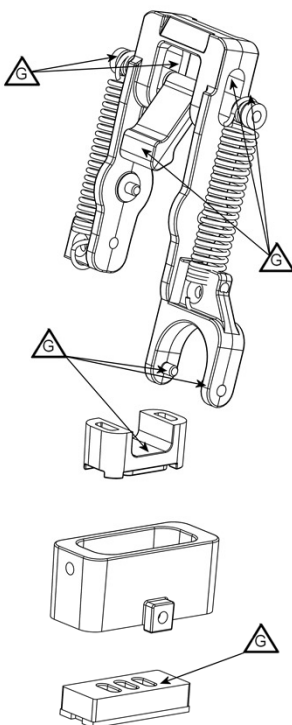
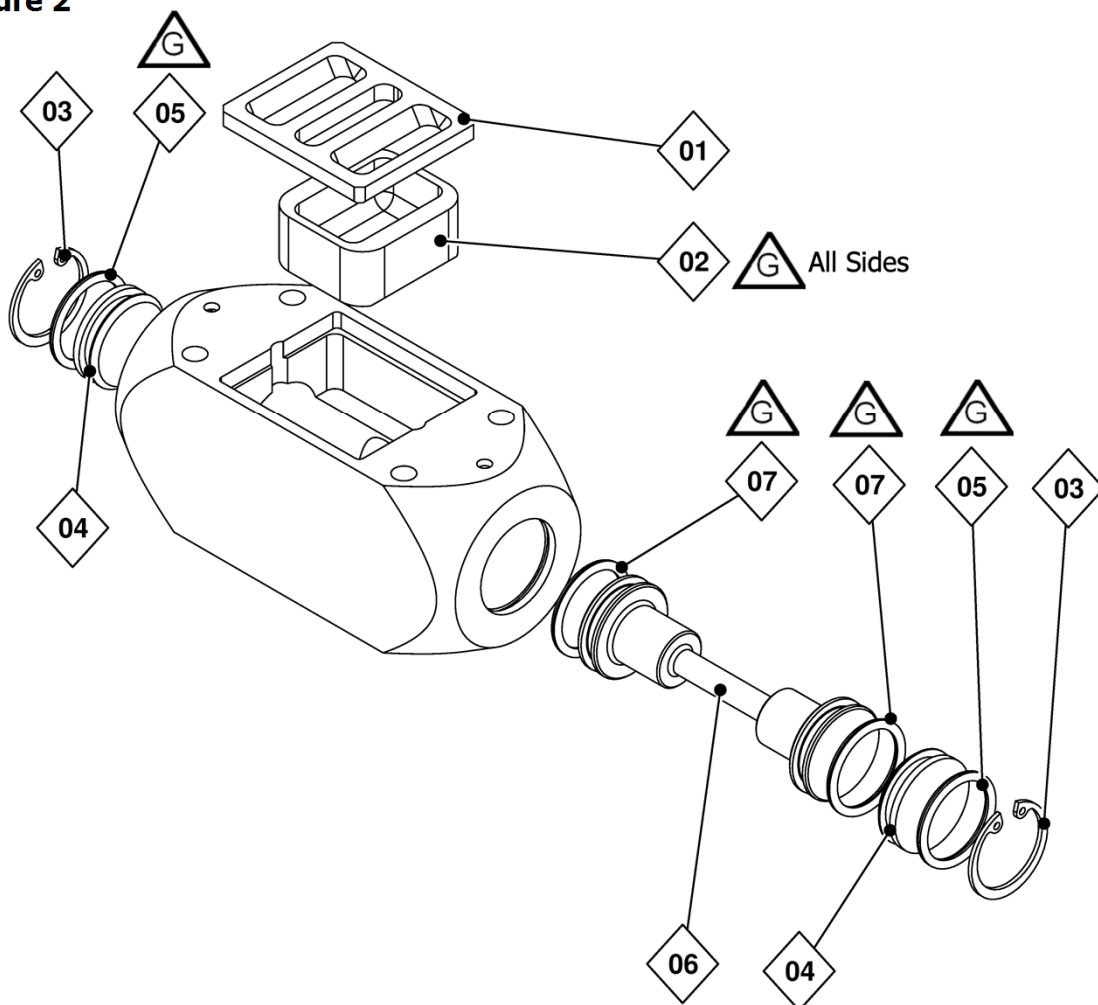
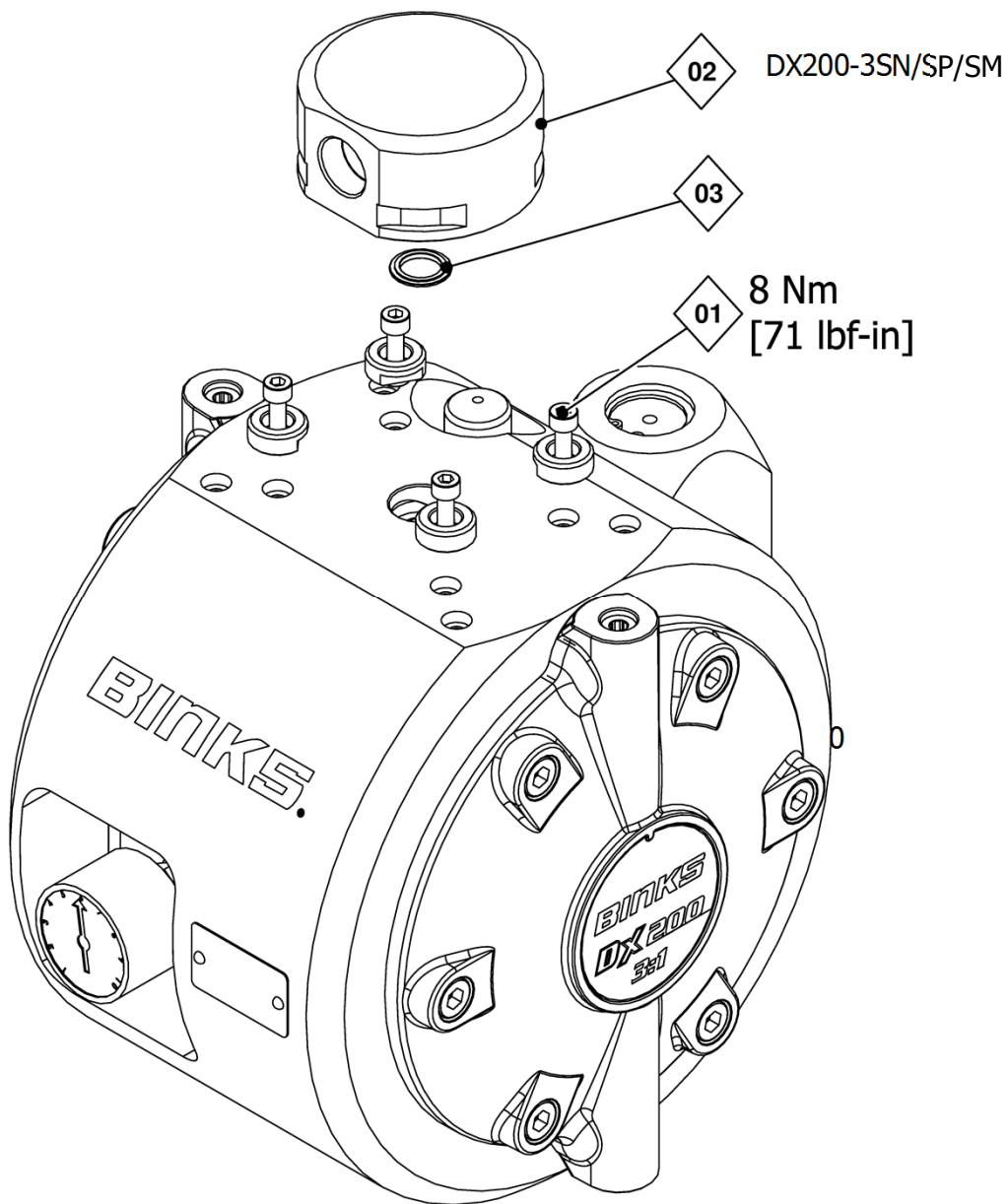

Figure 2



Maintenance

Figure 3



Maintenance schedule

0

Typical period	Recommended operation
Monthly	<ul style="list-style-type: none"> - Check for fluid or air leaks - Inspect Pump for Correct operation - Check for any excessive mechanical noise - Check for excessive fluid pressure pulsation
6 Months	<p>Perform a pump stop test to ensure correct operation, by ensuring pump stops when the spraygun trigger is closed and there is no fluid flow. If pump does not stop inspect ball check valves, replace as required.</p> <ul style="list-style-type: none"> - Check fluid regulator adjusts fluid pressure correctly. Replace if faulty
12 Months	<ul style="list-style-type: none"> - Replace Diaphragms - Replace fluid regulator seat and diaphragm - Replace centre shaft and seals - Replace Check valves - Inspect and replace if required:- Air Valve module

Fault finding

Symptom	Possible Cause	Remedy
Pump will not 'Prime'	<ul style="list-style-type: none"> a. Air getting into the suction hose/manifold b. Check valve ball/seal damaged 	<ul style="list-style-type: none"> a. Check hose connections b. Inspect, clean/replace balls/seats
Pump will not run	<ul style="list-style-type: none"> a. No Air or Fluid supply b. Air valve worn or defective 	<ul style="list-style-type: none"> a. Check air and fluid supply ball valves and supply hoses. b. Replace valve module.
Pump runs but has excessive pulsation	<ul style="list-style-type: none"> a. Air getting into fluid line, air supply restricted. b. Fluid check valves damaged c. Worn centre shaft/seals d. Worn air valve 	<ul style="list-style-type: none"> a. Check seals and hose connections. Check air supply b. Remove, clean, and inspect seat, ball, and ball cage. Replace if suspect or worn. c. Replace shaft and seals. d. Replace air valve module

Bare pump selection

DX200-3

S	N
---	---

 -

1

Pump body

S	Stainless Steel
----------	-----------------

Air regulators

-	No regulator
1	1 Regulator

Fluid regulator/Pulsation chamber

M	Manual Regulator
N	No regulator
P	Pulsation Chamber

Air regulators

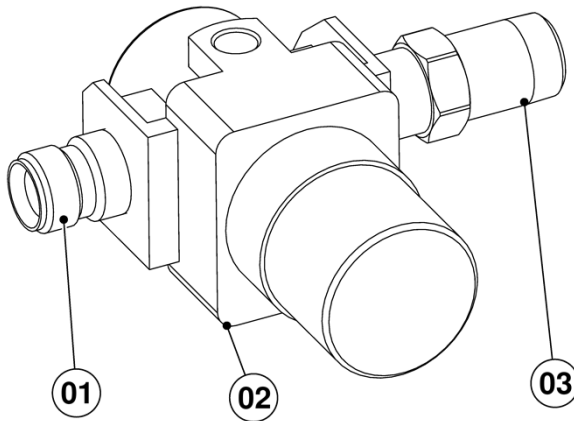

DXA-AC1-200-3 1 Regulator
- Pump

Item	Part No.	Description
1	180584	Nipple
2	DVX-353	Air Regulator
3	DVX-354	Nipple

NOTES

NOTES

NOTES

WARRANTY POLICY

Binks products are covered by Carlisle Fluid Technologies five year materials and workmanship limited warranty. The use of any parts or accessories, from a source other than Carlisle Fluid Technologies, will void all warranties. For specific warranty information please contact the closest Carlisle Fluid Technologies location listed below.

Carlisle Fluid Technologies reserves the right to modify equipment specifications without prior notice. DeVilbiss®, Ransburg®, MS®, BGK® and Binks® are registered trademarks of Carlisle Fluid Technologies, Inc.

© 2016 Carlisle Fluid Technologies, Inc.

All rights reserved.



Binks is part of Carlisle Fluid Technologies, a global leader in innovative finishing technologies. For technical assistance or to locate an authorized distributor, contact one of our international sales and customer support locations below.

USA/Canada

www.binks.com
info@carlisleleft.com
Toll Free Tel: 1-800-992-4657
Toll Free Fax: 1-888-246-5732

Mexico

www.carlisleleft.com.mx
ventas@carlisleleft.com.mx
Tel: 011 52 55 5321 2300
Fax: 011 52 55 5310 4790

Brazil

www.devilbiss.com.br
vendas@carlisleleft.com.br
Tel: +55 11 5641 2776
Fax: +55 11 5641 1256

United Kingdom

www.carlisleleft.eu
info@carlisleleft.eu
Tel: +44 (0)1202 571 111
Fax: +44 (0)1202 573 488

France

www.carlisleleft.eu
info@carlisleleft.eu
Tel: +33(0)475 75 27 00
Fax: +33(0)475 75 27 59

Germany

www.carlisleleft.eu
info@carlisleleft.eu
Tel: +49 (0) 6074 403 1
Fax: +49 (0) 6074 403 281

China

www.carlisleleft.com.cn
mkt@carlisleleft.com.cn
Tel: +8621-3373 0108
Fax: +8621-3373 0308

Japan

www.ransburg.co.jp
overseas-sales@carlisleleft.co.jp
Tel: 081 45 785 6421
Fax: 081 45 785 6517

Australia

www.carlisleleft.com.au
sales@carlisleleft.com.au
Tel: +61 (0) 2 8525 7555
Fax: +61 (0) 2 8525 7575

