

BINKS[®]

Instruction Manual

Back Pressure Regulator (Low Shear 1 1/2")

- **107754 – Manual Control**
- **107755 – Pilot Control**

Note: Read and follow all instructions and safety precautions before using this equipment

Product Description

107754 Low Shear Back Pressure Regulator
107755 Low Shear Back Pressure Regulator



This equipment is designed for use with Solvent based and Waterborne materials.
Suitable for use in Zone 1 and 2, Protection Level: **II 2 G X**

Manufacturer: - Binks PCE
Justus-von-Liebig-Straße 31,
63128 Dietzenbach. DE

EU Declaration of Conformity

We: Binks declare that the above product conforms with the Provisions of Machinery Directive 2006/42/EC and the ATEX Directive 94/9/EC by complying with the following statutory documents and harmonized standards: -

Machinery Safety Standards EN ISO 12100, EN ISO 4413, EN ISO 4414 & EN12621
Explosion Prevention Potentially Explosive Atmospheres EN 1127-1
Non-electrical Equipment for Potentially Explosive Atmospheres BS EN 13463-1
Constructional Safety for Potentially Explosive Atmospheres EN 13463-5

Providing all conditions of safe use stated within the product manuals have been complied with and that the final equipment into which this product is installed has been re-assessed as required, in accordance with essential health and safety requirements of the above standards, directives and statutory instruments and also installed in accordance with any applicable local codes of practice.

A handwritten signature in black ink, appearing to read 'H. Beiersdorfer'.

H Beiersdorfer (General Manager)
26th October 2010

Index

Section

- 1.1 General Description
- 1.2 Model Selection

- 2.1 Installation – Mounting
- 2.2 Installation – Setting to work

- 3.1 Assembly Procedure
- 3.2 Parts Lists

- 4.1 Spare Parts List

- 5.1 Important Information

General Description – Section 1.1

A range of Binks low shear back pressure regulators are available to suit most pressure and technical requirements for paint circulating systems.

Model	Ideal Working Range		Max Static Pressure	Wetted Materials
107754 - 15 Bar	3-15 Bar	10 – 90 L/min	25 Bar	300 Series Stainless Steel & Modified PTFE
107755 - Pilot	1-15 Bar	10 – 90 L/min	25 Bar	

This equipment is designed for use with Solvent based and Waterborne materials. Suitable for use in Zone 1 and 2, Protection Level: II 2 G X

The Binks low shear back pressure regulators adjust to control the paint system back pressure within the pipe line and minimise 'paint shear' due to the large surface area of the valve seating.

The 'back pressure' regulator responds to the changes in system fluid pressure, (due to variable paint usage) by dynamically adjusting to maintain the set pressure, thus maintaining the required system back pressure.

If the pressure in the system drops below the regulated level (system demand exceeds pump supply rate) then the valve will close.

Manual or Air pilot Control Models are available with a range of standard or customer specified connections, see selection chart (section 1.2) for variants. The required connections are factory fitted and not intended for removal in the field.

Model Selection – Section 1.2

(Manual Control) 107754
 (Pilot Control) 107755 A-B-C etc

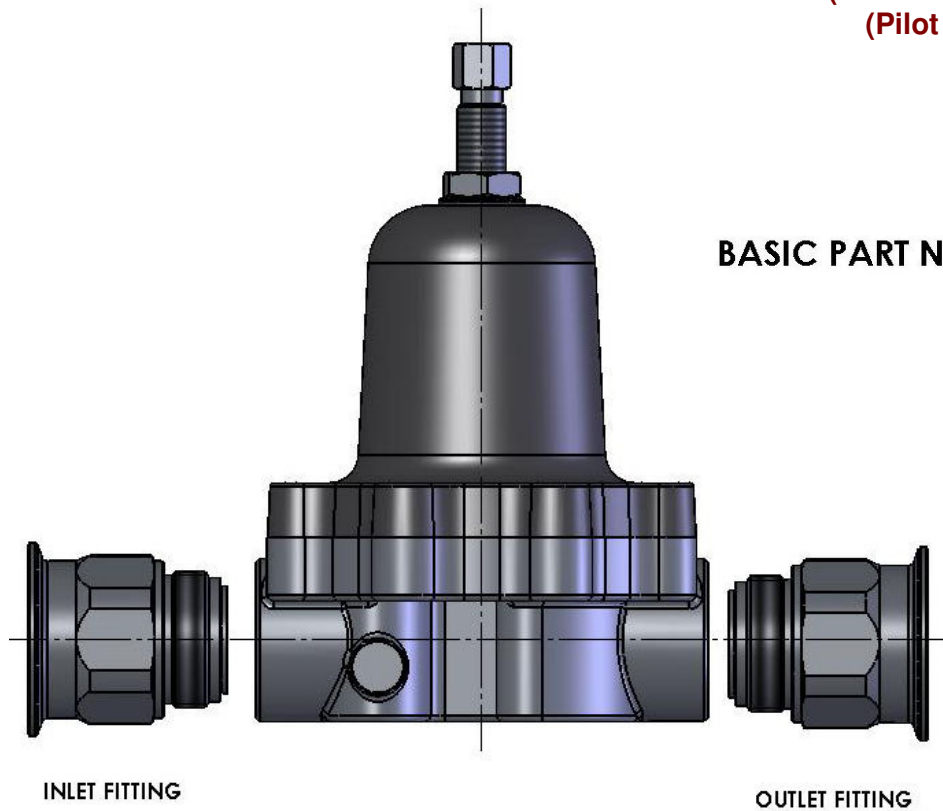

107754 - X - X

BASIC PART NUMBER

INLET FITTING

OUTLET FITTING

INLET FITTING

OUTLET FITTING

INLET / OUTLET FITTING SELECTION TABLE

SUFFIX	PART No	DESCRIPTION	REMARKS
A	192553	FITTING - M45 x SLIP FLANGE ASSEMBLY	DN 50 BS4504 PN16
B	192554	FITTING - M45 x 2" SANITARY	STANDARD
C	192555	FITTING - M45 x 1 1/2" SANITARY	STANDARD
D	192556	FITTING - M45 x 1 1/2" NPT (FEMALE)	
E	192557	FITTING - M45 x 1 1/2" BSPT (FEMALE)	
F	192558	FITTING - M45 x 42 MM COMPRESSION COUPLING	DIN 2353
G	192559	FITTING - M45 x 1 1/4" BSP (H)	
H	192560	FITTING - M45 x 1 1/2" BSP (H)	
I	192561	FITTING - M45 x ECOFITTING DN32 (35 O/D)	
J	192562	FITTING - M45 x ECOFITTING DN40 (40 O/D)	
K	192563	FITTING - M45 x ECOFITTING DN50 (50 O/D)	
L	192564	FITTING - M45 x 1" SANITARY	STANDARD
M	192565	FITTING - M45 x 2" SANITARY	BPR LENGTH = 272mm
N			

Installation - Mounting – Section 2.1

1. Connect the unit into the paint system pipework in the direction indicated by the arrow on the valve body.

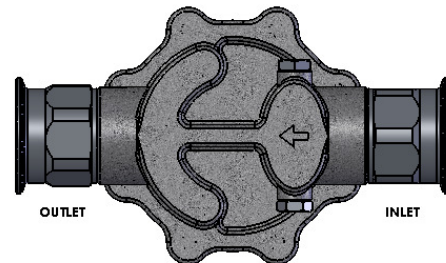

2. Always connect the unit using the correct fittings /gaskets and if a threaded fitting is used a suitable thread compatible sealant.
3. A pressure gauge should be mounted directly into the pipework on the inlet side of the unit to allow precise adjustment for the regulated back pressure. Alternatively 2 off gauge connection ports are provided in the valve body to suit orientation (See accessories for relevant part number.)

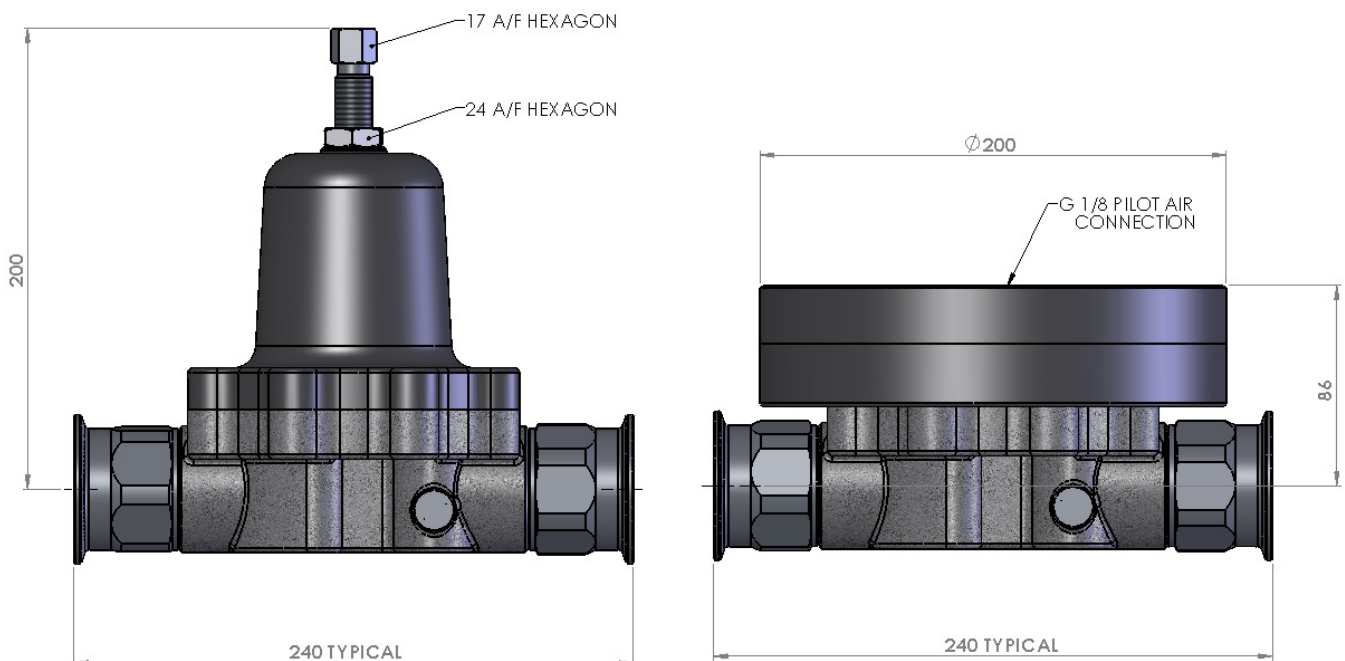

Installation – Setting to work – Section 2.2

The Back pressure regulator is tested with demineralised water, therefore the fluid chamber should be flushed with suitable material prior to use.

Note: Before attempting any maintenance ensure that all relevant directions for working safety are followed.

1. If circulating system pressure testing is carried out with the back pressure regulator in circuit, the fluid test pressure must not exceed 25 Bar and the back pressure valve **must** 'be unloaded' have no spring pressure (or air pressure) acting on the diaphragm.
2. When the paint pipework is to be flushed with the back pressure regulator installed, the back pressure regulator **must not** have any spring pressure (or air pressure) acting on the diaphragm. This status must remain until the paint system has been accepted as clean and contaminant free.
3. Following pressure testing and flushing procedures the diaphragms should be examined and replaced if necessary to ensure the integrity of the unit prior to use in production.
4. Turning the main adjusting screw clockwise will increase the spring pressure on the unit and therefore the fluid back pressure on the paint system. Turning the screw anti-clockwise will decrease back pressure. The Pilot controlled unit operates in the same way, an increase in pilot air pressure increases the system back pressure.
5. Adjust the spring (or pilot air pressure) until the desired system fluid back pressure is achieved on the pressure gauge in the BPR inlet pipework.

Installation – Setting to work – Section 2.2

Pilot Operated Fluid Back Pressure

The air pilot pressure should be adjusted until the reading on the pipework fluid gauge is showing the desired back pressure.

If no fluid gauge is available then the table below can be used as a basic guide.

Air Pilot relative to given Fluid Back Pressure	
Set Air Pilot Pressure - BAR	Fluid Back Pressure - BAR
6.0	17.0
5.5	15.5
5.0	14.3
4.5	12.9
4.0	11.4
3.5	10.2
3.0	8.8
2.5	7.5
2.0	6.1
1.5	4.6

Dismantling / Assembly Procedure – Section 3.1

The Back pressure regulator can be serviced and maintained without removing the unit from the paint pipework.

1. Fully unscrew the adjusting screw to remove all paint line pressure. Note grease should be re-applied to the thread as required. (For the case air pilot version isolate and completely exhaust the compressed air pilot supply)
2. Isolate the unit from the paint system pipework (and compressed air supply if applicable)
3. Position a suitable 'drip tray' underneath the unit to minimise any residual paint spillage when dismantling.
4. Unscrew the 8 off screws securing the bonnet; remove the diaphragm plate and diaphragms.
For the air pilot controlled version firstly remove the 12 off screws retaining the air pilot cap and remove with the air diaphragm, then remove the 8 off screws.
5. Clean any residual paint remaining within the fluid chamber. Clean all parts as required.
6. Reassemble the unit with new diaphragm; ensure PTFE side of the Fluid diaphragm is closest to the fluid chamber (face down).
7. Place the diaphragm plate on the diaphragm, fit the bonnet/base and tighten the 8 off Bonnet screws to 18 N-M (13 foot-pounds) Tighten opposed screws in stages to maintain an even clamping force.
For the pilot version assemble the air diaphragm (rubber side towards the air connection) and end cap with the 12 screws. Tighten to 18 N-M (13 foot-pounds)
8. Pressure test with 6 bar compressed air and check for leaks.
9. Reintroduce the paint system pressure and adjust the back pressure regulator to the required setting.

Parts Lists – Section 3.2

Part List -107754 (15 Bar BPR)				
ITEM	PART NUMBER	DESCRIPTION	QTY	REMARKS
1	192548	BASE - MACHINING (1 1/2 BPR)	1	
2	192546	BONNET - MACHINING	1	
3	193232	FLUID DIAPHRAGM	1	
4				
5	192585	DIAPHRAGM PLATE	1	
6	192549	ADJUSTING SCREW	1	17 A/F HEXAGON
7	160406	SPRING - 15 BAR BPR	1	
8	191964	BUTTON	1	
9	192551	HEXAGON PLUG - 1/4 BSP	2	17 A/F HEXAGON
10	164472	M8 x 25 CAP HD SCREW ST ST	8	
11	163060	M16 LOCKNUT ST ST	1	
12	161981	O-RING Ø36	2	
13	192505	O-RING Ø12	2	

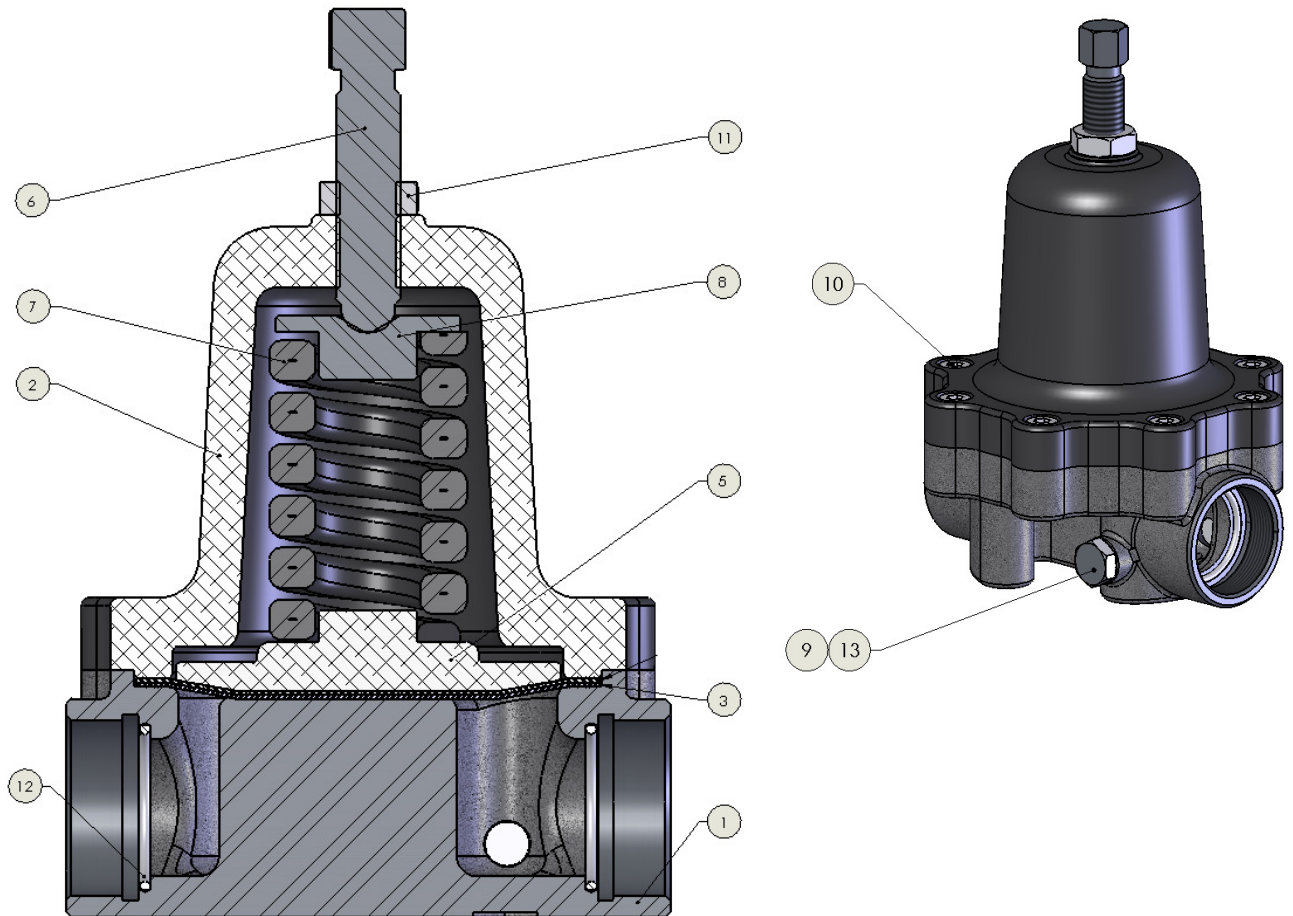

Parts Lists – Section 3.2

Part List -107755 (Pilot BPR)				
ITEM	PART NUMBER	DESCRIPTION	QTY	REMARKS
1	192548	BASE - MACHINING (1 1/2 BPR)	1	
2				
3	193232	FLUID DIAPHRAGM	1	
4	192551	HEXAGON PLUG - 1/4 BSP	2	17 A/F HEXAGON
5	192586	DIAPHRAGM PLATE	1	
6	192587	BASE	1	
7	192540	PILOT DIAPHRAGM	1	
8	192537	CAP	1	
9	163962	M8 x 30 CAP HD SCREW ST ST	12	
10	165961	M8 x 20 CAP HD SCREW ST ST	8	(NOT SHOWN)
11	161981	O-RING Ø36	2	
12	192505	O-RING Ø12	2	(NOT SHOWN)
13	174647	1/8 -4 MM STUD ELBOW	1	(NOT SHOWN)

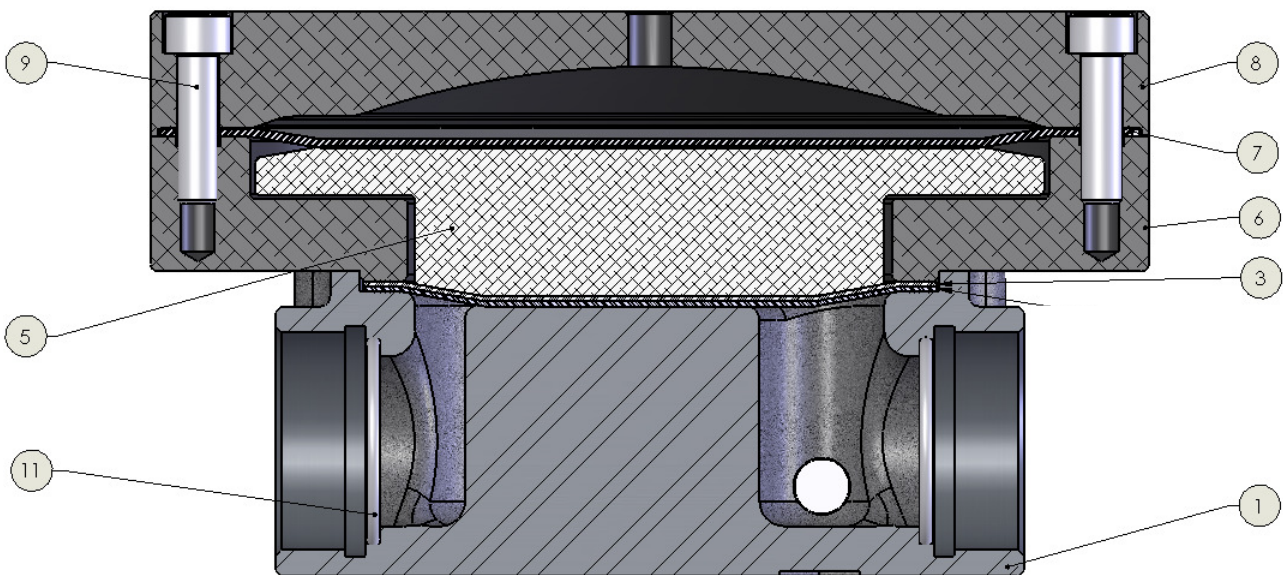

Spare Parts List – Section 4.1

107754 Spare Part List - 250602				
ITEM	PART NUMBER	DESCRIPTION	QTY	REMARKS
3	193232	FLUID DIAPHRAGM	1	
13	192505	O-RING	1	

107755 Spare Part List - 250603				
ITEM	PART NUMBER	DESCRIPTION	QTY	REMARKS
3	193232	FLUID DIAPHRAGM	1	
7	192540	PILOT DIAPHRAGM	1	
12	192505	O-RING	1	

Important Safety Information - Section 5.1

Directions for Working Safety

This Product has been constructed according to advanced technological standards and is operationally reliable. Damage may, however, result if it is used incorrectly by untrained persons or used for purposes other than those for which it was constructed.

The locally current regulations for safety and prevention of accidents are valid for the operation of this product under all circumstances.

International, national and company safety regulations are to be observed for the installation and operation of this product, as well as the procedures involved in maintenance, repairs and cleaning.

These instructions are intended to be read, understood and observed in all points by those responsible for this product. These operating and maintenance instructions are intended to ensure trouble free operation. Therefore, it is recommended to read these instructions carefully before start-up. Binks PCE cannot be held responsible for damage or malfunctions resulting from the non-observance of the operating instructions. These instructions including regulations and technical drawings may not be copied, distributed, used for commercial purposes or given to others either in full or in part without the consent of Binks PCE.

We reserve the right to alter drawings and specifications necessary for the technical improvement of this product without notice.

High Pressure/Electrostatic Warning

High pressure equipment can be dangerous if used incorrectly, serious bodily injury may occur if the following instructions are ignored. Installation and maintenance should only be carried out by suitably qualified personnel.

1. Before attempting any work on a high-pressure system ensure material pump, hydraulics, compressed air motor are isolated where relevant.
 2. Relieve all pressure from the system. Note: It is possible for pressure to get locked into a system, therefore, ensure all sections of the system are checked thoroughly for remaining pressure.
 3. Take care when releasing fittings
 4. Always replace worn hoses immediately
 5. Never plug a leak with your finger, adhesive tape or other stop gap devices
- Always ensure equipment is suitably earthed before running, to avoid any chance of electrostatic build up.

Equipment Misuse Hazard

Equipment misuse can cause the equipment to rupture or malfunction and result in serious injury.

- This equipment is for professional use only.
- Read all instruction manuals, tags, and labels before operating the equipment.
- Use the equipment only for its intended purpose.
- Do not alter or modify this equipment. Use only genuine Binks PCE parts and accessories.
- Check equipment daily. Repair or replace worn or damaged parts immediately.
- Do not exceed the maximum working pressure stated on the equipment or in the Technical Data for your equipment. Do not exceed the maximum working pressure of the lowest rated component in your system.
- Use fluids and solvents which are compatible with the equipment wetted parts. Refer to the Technical Data section of all equipment manuals. Read the fluid and solvent manufacturer's warnings.
- Route hoses away from traffic areas, sharp edges, moving parts, and hot surfaces. Do not expose hoses to temperatures above 82°C (180°F) or below -40°C (-40°F).
- Wear hearing protection when operating this equipment.
- Do not lift pressurized equipment.
- Comply with all applicable local, state, and national fire, electrical, and safety regulations.

Important Safety Information - Section 5.1

Fire, Explosion and Electric Shock Hazard

Improper grounding, poor ventilation, open flames or sparks can cause a hazardous condition and result in a fire, explosion, or electric shock.

When installed and operated in accordance with its instructions, the unit is approved for operation in Zone 1 (Europe) & Division 1 (North America), hazardous locations. (ATEX Cat 2)

- Electrical equipment must be installed, operated, and serviced only by trained, qualified personnel who fully understand the requirements stated in this instruction manual.
- Ground the equipment and all other electrically conductive objects in the spray area. Keep all covers tight while the motor is energized.
- If there is any static sparking or you feel an electric shock while using this equipment, stop spraying/dispensing immediately. Do not use the equipment until you identify and correct the problem.
- Provide fresh air ventilation to avoid the build up of flammable fumes from solvents or the fluid being pumped.
- Keep the pumping area free of debris, including solvent, rags, and gasoline.
- Electrically disconnect all equipment in the pumping area.
- Extinguish all open flames or pilot lights in the spray/dispense area.
- Do not smoke in the spray/dispense area.
- Do not turn on or off any light switch in the spray/dispense area while operating or if fumes are present.
- Do not operate a gasoline engine in the spray/dispense area.

Hot Surface Hazard

- The electric motor becomes hot during operation, and the heat may be transferred to other connected equipment. To reduce the risk of burning yourself, do not touch the motor surfaces while it is operating. Before servicing, allow the motor to cool.
- Keep flammable materials and debris away from the equipment.

Pressurized Equipment Hazard

Spray from the gun/valve, hose leaks, or ruptured components can splash fluid in the eyes or on the skin and cause serious injury.

- Do not point the gun/valve at anyone or at any part of the body.
- Do not stop or deflect leaks with your hand, body, glove or rag.
- Follow the Pressure Relief Procedure whenever you: are instructed to relieve pressure; stop spraying/dispensing; clean, check, or service the equipment.
- Tighten all fluid connections before operating the equipment.
- Check the hoses, tubes, and couplings daily. Replace worn, damaged, or loose parts immediately. Permanently coupled hoses cannot be repaired; replace the entire hose.

Toxic Fluid Hazard

Hazardous fluid or toxic fumes can cause serious injury or death if splashed in the eyes or on the skin, inhaled, or swallowed.

- Know the specific hazards of the fluid you are using.
- Store hazardous fluid in an approved container. Dispose of hazardous fluid according to all local, state and national guidelines.
- Always wear protective eyewear, gloves, clothing and respirator as recommended by the fluid and solvent manufacturer.

Moving Parts Hazard

Moving parts, such as the cam and drive mechanism, can pinch or amputate your fingers.

- Keep clear of all moving parts when starting or operating the pump.
- Never remove the drive section cover while operating the pump.

Before servicing the equipment prevent the equipment from starting unexpectedly



Justus-von-Liebig-Straße 31, 63128 Dietzenbach. DE
Tel. +49 (0) 6074 403 1 Fax. +49 (0) 607 403 300
General e-mail: info@finishingbrands.eu

Ringwood Road, Bournemouth, Dorset BH11 9LH. UK
Tel. +44 (0)1202 571 111 Fax. +44 (0)1202 573 488
General e-mail: info@finishingbrands.eu

163-171, Av. des Auréats, 26014 Valence cedex. FR
Téléphone : +33 (0) 4 75 75 27 53 Télécopie: +33 (0) 4 75 75 27 79
General e-mail: info@finishingbrands.eu

USA Canada Customer Service

195 Internationale Blvd.
Glendale Height, IL 60139
630-237-5000

Toll Free Customer Service and
Technical Support 800-992-4657
Toll Free Facsimile 800-246-5732