

***AutoCure 6000 - 2216* Overhead Heater Assembly and Operating Manual**



AC6-2216 TABLE OF CONTENTS

1.	WARNINGS AND DANGER	4
	• WARNING, CAUTION & NOTE	5
2.	EQUIPMENT SAFETY GUIDELINES	
	• CAUTION	6
	• Lamps, Pyrometer Positioning Beam, Environment	7
3.	OPERATING INSTRUCTIONS	
	• Temperature Controllers Single or Double Ramp Operation	8
	• Temperature Controller Displays.....	8
	• Cycle Start Button, Heater Position.....	8
	• Setting the Temperature Controller Parameters.....	9
4.	LAMP INSTALLATION AND REPLACEMENT INSTRUCTIONS	
	• DANGER!! Precautions for Handling Quartz Infrared Lamps	10
	• CAUTION!! Lamp Instruction/Replacement Procedure	10
5.	HEATER POSITION INSTRUCTIONS	
	• General Instructions (Read All)	11
	• Heat Masking.....	12
	• Positioning/Set-up of Heater Head Instructions.....	12-13
	• Yellow Pendant (for overhead arm movement)	14
6.	MAINTENANCE	
	• Actuator & Pivot Points	15
	• Lamps, Reflectors and Heat Sensor (Pyrometer) Lens	15
7.	TROUBLESHOOTING GUIDE	
	• Heater Power Problems.....	16
	• Temperature Controller Problems.....	17
	• Temperature Problems	18
8.	TEMPERATURE CONTROLLER ERROR CODES	19
9.	PYROMETER ASSEMBLY (DRAWING# AC-61231 – 4 pgs)	20-23
10.	SERVICE INSTRUCTIONS FOR PYROMETER	24
	• Old and New Raytek Units (2 pgs).....	25-26
	• Replacement of New Pyrometer Sensor (2 pgs)	27-28
	• Replacement of Pyrometer Controller (2 pgs)	28-29

- Verification / Calibration Procedure.....30
 - Begin Verification / Calibration Cycle31
 - Verify “Lock” Status of Raytek Comm Module31
 - Adjusting Raytek Calibration Procedure (3 pgs).....32-34
 - Begin Calibration Cycle.....34
 - Calibration Adjustment35
- “Lock” Out the Comm Box36
- 11. **SINGLE HEAD BACK PANEL/BILL OF MATERIAL**.....37-38
- 12. **JUNCTION BOX**39
- 13. **MECHANICAL DRAWINGS/PARTS LIST (3 pgs)**40-42
- 14. **TABLES (4 pgs)**.....43-46
- 15. **AUTOCURE MODEL NUMBERS**47
 - AC6-2216-480-SP47
 - Electrical Schematic (2 pgs).....48-49
 - Spray/Bake50
 - Heater Heads (5 pgs).....51-55
 - Recommended Spare Parts56
- 16. **BGK-CARLISLE FLUID TECHNOLOGIES CUSTOM PRODUCTS WARRANTY**57



1. Warnings and Danger



**DANGEROUS VOLTAGES ARE
PRESENT IN THIS EQUIPMENT!**

**CONTACT WITH LIVE PARTS
COULD CAUSE
SERIOUS INJURY OR DEATH!**

**CONNECTION, INSTALLATION, MAINTENANCE,
ADJUSTMENT, SERVICING AND OPERATION TO BE
DONE BY QUALIFIED PERSONNEL ONLY.**

**ENSURE THAT EQUIPMENT IS COMPLETELY
AND PROPERLY GROUNDED BEFORE APPLYING
SUPPLY POWER AND BEFORE EQUIPMENT
OPERATION.**

In this manual, the words **WARNING**, **CAUTION** and **NOTE** are used to emphasize important safety information as follows:

WARNING

Hazards or unsafe practices which could result in severe personal injury, death or substantial property damage.

CAUTION

Hazards or unsafe practices which could result in minor personal injury, product or property damage.

NOTE

Important installation, operation or maintenance information.

WARNING

Read the following warnings before using this equipment



READ THE MANUAL

Before operating finishing equipment, read and understand all safety, operation and maintenance information provided in the operation manual.



OPERATOR TRAINING

All personnel must be trained before operating finishing equipment.



EQUIPMENT MISUSE HAZARD

Equipment misuse can cause the equipment to rupture, malfunction, or start unexpectedly and result in serious injury.



LOCK OUT / TAG-OUT

Failure to de-energize, disconnect, lock out and tag-out all power sources before performing equipment maintenance could cause serious injury or death.



AUTOMATIC EQUIPMENT

Automatic equipment may start suddenly without warning.



PRESSURE RELIEF PROCEDURE

Always follow the pressure relief procedure in the equipment instruction manual.



KEEP EQUIPMENT GUARDS IN PLACE

Do not operate the equipment if the safety devices have been removed.



KNOW WHERE AND HOW TO SHUT OFF THE EQUIPMENT IN CASE OF AN EMERGENCY



WEAR SAFETY GLASSES

Failure to wear safety glasses with side shields could result in serious eye injury or blindness.



INSPECT THE EQUIPMENT DAILY

Inspect the equipment for worn or broken parts on a daily basis. Do not operate the equipment if you are uncertain about its condition.



NEVER MODIFY THE EQUIPMENT

Do not modify the equipment unless the manufacturer provides written approval.



NOISE HAZARD

You may be injured by loud noise. Hearing protection may be required when using this equipment.

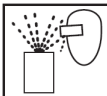

PROJECTILE HAZARD

You may be injured by venting liquids or gases that are released under pressure, or flying debris.



PINCH POINT HAZARD

Moving parts can crush and cut. Pinch points are basically any areas where there are moving parts.



STATIC CHARGE

Fluid may develop a static charge that must be dissipated through proper grounding of the equipment, objects to be sprayed and all other electrically conductive objects in the dispensing area. Improper grounding or sparks can cause a hazardous condition and result in fire, explosion or electric shock and other serious injury.



WEAR RESPIRATOR

Toxic fumes can cause serious injury or death if inhaled. Wear a respirator as recommended by the fluid and solvent manufacturer's Safety Data Sheet.



TOXIC FLUID & FUMES

Hazardous fluid or toxic fumes can cause serious injury or death if splashed in the eyes or on the skin, inhaled, injected or swallowed. LEARN and KNOW the specific hazards or the fluids you are using.



FIRE AND EXPLOSION HAZARD

Improper equipment grounding, poor ventilation, open flame or sparks can cause a hazardous condition and result in fire or explosion and serious injury.



MEDICAL ALERT

Any injury caused by high pressure liquid can be serious. If you are injured or even suspect an injury:

- ◆ Go to an emergency room immediately.
- ◆ Tell the doctor you suspect an injection injury.
- ◆ Show the doctor this medical information or the medical alert card provided with your airless spray equipment.
- ◆ Tell the doctor what kind of fluid you were spraying or dispensing.



GET IMMEDIATE MEDICAL ATTENTION

To prevent contact with the fluid, please note the following:

- Never point the gun/valve at anyone or any part of the body.
- Never put hand or fingers over the spray tip.
- Never attempt to stop or deflect fluid leaks with your hand, body, glove or rag.
- Always have the tip guard on the spray gun before spraying.
- Always ensure that the gun trigger safety operates before spraying.



**CA PROP
65**

PROP 65 WARNING

WARNING: This product contains chemicals known to the State of California to cause cancer and birth defects or other reproductive harm.

It is the responsibility of the employer to provide this information to the operator of the equipment.

For further safety information regarding this equipment, see the General Equipment Safety Booklet (77-5300).

2. Equipment Safety Guidelines

(Read and understand this manual before operating equipment.)

CAUTION!!

1. Turn power off at source before servicing equipment or attempting any electrical or mechanical maintenance, especially lamp replacement.
2. If the control panel main power switch is ON, voltage may exist at the lamps even though the lamps are not emitting light. AN ELECTRICAL SHOCK COULD POSSIBLY RESULT!
3. Heater head(s) contains high voltage. Do not insert metallic objects into cooling louver openings.
4. Before applying supply power, make sure the AutoCure arm(s) are grounded properly before equipment operation.
5. Before each operation of the AutoCure arm(s), inspect the repair arm(s) heater lamp(s). If any lamps are broken or break at any time, shut the power off and discontinue use. When the damaged or broken lamp(s) are replaced by the qualified personnel, turn the power back on.
6. This is an automatic piece of equipment. Heater can very quickly come on to full intensity without warning to unaware personnel.
7. Heater surfaces can become hot when used at high power for extended periods. Use caution whenever handling heater head(s). The heater head(s) have black insulated handles to use for moving or manipulating heater head(s).
8. Do not move heater when in operation because it will move the temperature sensor viewing area and the heater head's distance to product. If the heater accidentally moves, check temperature sensor viewing area with the "Positioning Beam" and verify acceptable positioning of heater head.
9. Use care when manipulating or positioning heater head(s) and arms. Avoid possible pinch points.
10. The positioning beam/pyrometer must be aimed at the surface target to be heated. If it is not properly aimed at the surface target, (i.e. aimed into open air) the pyrometer will read a lower temperature causing the unit to go to high lamp intensities for abnormal time lengths. If used in this condition for extended period of time, it can damage the unit.
11. When the unit is NOT in operation, the E-stop button MUST be pressed for safety of personnel, unit, and other material/equipment in vicinity of the heater head(s).

LAMPS

All lamp end covers and grills must be installed before operating and using the repair arms to avoid electrical shock.

The lamps of the repair arms have similarities to a standard incandescent light bulb. During the repair arm curing cycle, the repair arm lamps can sometimes emit bright light similar to a standard incandescent light bulb. As you would with an incandescent light bulb, we high recommend you **DO NOT STARE DIRECTLY INTO THE BRIGHT LIGHT.**

DO NOT HANDLE INFRARED LAMPS WITH BARE HANDS. Remove any contamination with alcohol and a clean, soft cloth. Contamination on quartz tubes allows the quartz to overheat, which leads to premature lamp failure.

PYROMETER POSITIONING BEAM

A class 2 laser emits in the visible region (635-870mN) at 1mW of power. The blink reflex of the human eye (aversion response) will prevent eye damage, unless the person deliberately stares into the beam for an extended period. **DO NOT STARE INTO THE BEAM.**

ENVIRONMENT

Heater head contains high voltage connections that are open to atmosphere. These units are not air-purged. Ensure use of unit is acceptable in the area in which it will be used.

3. Operating Instructions

Temperature Controller Single or Double Ramp Operation (See Figure 1)

Single Ramp Operation: The temperature ramps in a predetermined amount of time from ambient to a set point temperature and holds at that temperature for a required amount of time.

Double Ramp Operation: The temperature ramps in a predetermined amount of time from ambient to the first set point temperature and holds at that temperature for a required amount of time, it then ramps in a predetermined amount of time to a second set point temperature and holds at that temperature for a required amount of time.

Temperature Controller Displays

The upper display indicates the mode of the heating cycle and the process temperature. During the Ramp mode the upper display will toggle between the process temperature and ramping. Once the cure temperature (set point) has been reached the upper display will toggle between the hold time remaining (in minutes) and the process temperature. When the hold time becomes less than one minute the upper display will toggle between the hold time remaining (in seconds) and the process temperature. The lower display indicates the cure temperature (set point).

Cycle Start Button

The product will heat to the set point temperature and remain there for the time selected. The hold time will start when the temperature reaches 15°F before set point.

Heater Position





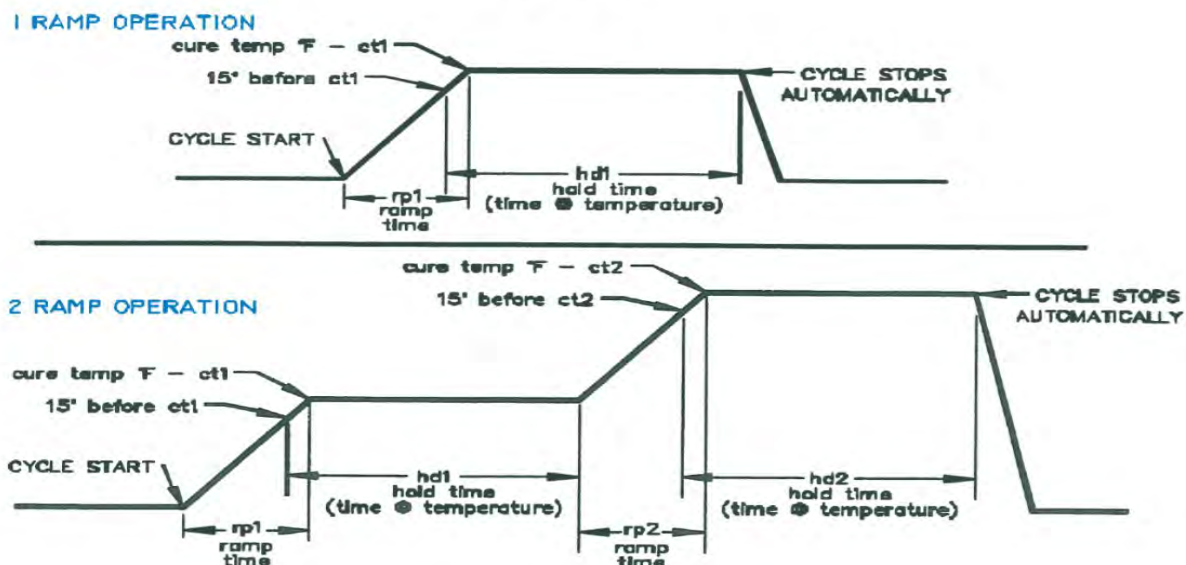







If the heater is too far from the product, the temperature will not be reached and the hold timer will not be activated.

Figure 1



Setting the Temperature Controller Parameters (See Figure 2)

Single Ramp

1. Turn power on.
2. Turn positioning beam on and position heater.
3. Set controller parameters
4. Hold the  button for 1-2 seconds
 - a. Set rp1 (ramp time) in minutes  
Press 
 - b. Set ct1 (cure temp) in degrees  
Press 
 - c. Set hd1 (hold time) in minutes  
Press 
 - d. Set rp2 = 0 (this disables 2nd ramp)
Press 
5. Press the  to exit setup menu
6. Set auxiliary heater off or on
7. Press the cycle start

Double Ramp





















1. Turn power on.
2. Turn positioning beam on and position heater.
3. Set controller parameters
4. Hold the  button for 1-2 seconds
 - a. Set rp1 (ramp time) in minutes  
Press 
 - b. Set ct1 (cure temp) in degrees  
Press 
 - c. Set hd1 (hold time) in minutes  
Press 
 - d. Set rp2 (2nd ramp time) in minutes  
Press 
 - e. Set ct2 (2nd cure temp) in degrees  
Press 
 - f. Set hd2 (2nd hold time) in minutes  
Press 
5. Press the  to exit the setup menu
6. Set auxiliary heater off or on
7. Press cycle start

Figure 2



4. Lamp Installation and Replacement Instructions

Danger!!

Turn power off at source before removing end covers and servicing lamps. A fatal electrical shock could possibly result.

Precautions for Handling Quartz Infrared Lamps

Do not handle infrared lamps with bare hands. Remove any contaminations with alcohol and a clean, soft cloth. Contaminations on quartz tubes cause the quartz to overheat, which may lead to premature lamp failure.

Caution!!

If lamps are replaced, with lamps having metal ends, metal ends must be removed to permit proper assembly and prevent the possibility of arcing or shorting.

Lamp Installation / Replacement Procedure

1. Make sure main system circuit breaker is OFF.
2. Rotate heater so lamps are horizontal.
3. Remove end covers to gain access to lamp leads.
4. Disconnect wire from the ceramic terminal block and remove lamp that is being replaced.
5. Carefully slide the lamp through the lamp support.
6. Remove electrical insulation sleeves from the old lamp on both lamp leads and install them on the new lamp leads. Push the sleeve to the ceramic end of the lamp (see drawing below).
7. Secure the lamp lead to the power wire coming into the heater at the ceramic terminal block.
8. Install end covers.

NOTE: If lamp leads are too tight, damage to lamp may result.

Make sure lamp sleeving is pushed all the way into ceramic end of lamp

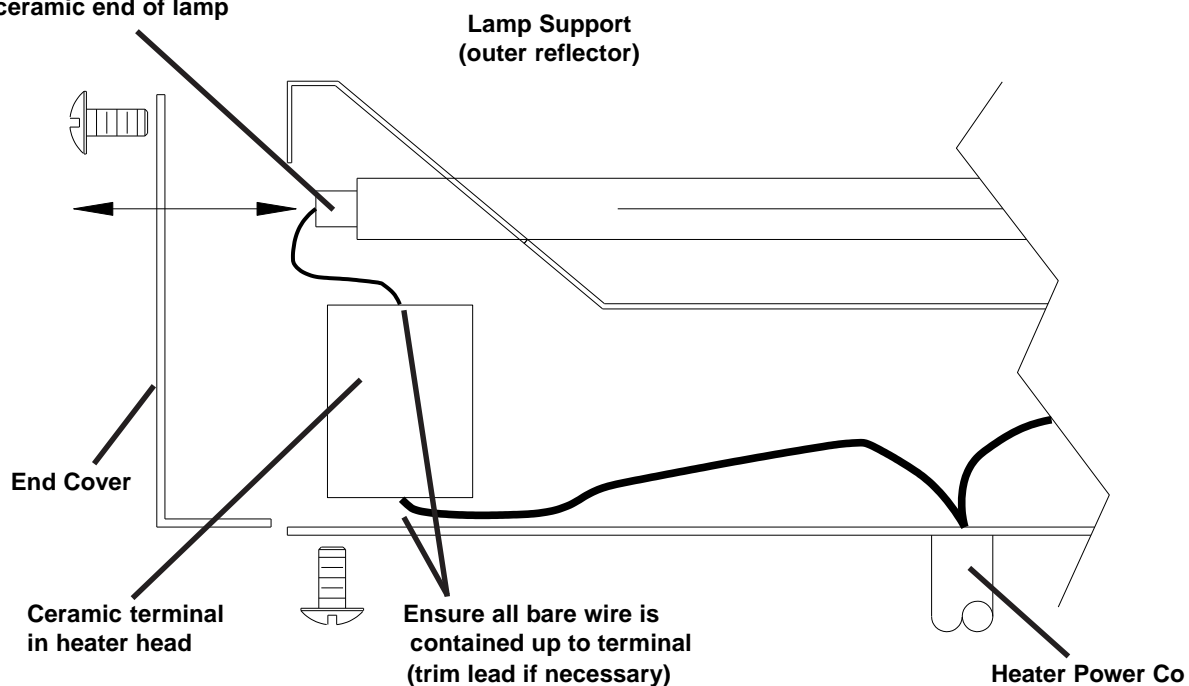

5. Heater Position Instructions

Important: Precautions and Instructions

General Instructions (Read All)

1. The "Positioning Beam" (red dot) is an aid for proper placement of the heat sensor. The heat sensor reads an area of 0.8 to 1.2" diameter depending on the heater's distance from the surface. The sensor takes an average temperature reading of the area and displays it on the temperature controller. **Note: the red dot is not at the exact center of the sensing area. As you face the control panel the dot is 3/4" to the left of the heat sensor.**
2. Make sure the heat sensing area is reading a painted surface. If the sensing area is positioned incorrectly and is partially reading tape, masking, trim, plastic, rubber, a window, or a wheel well, it will measure an average temperature much higher or lower than the actual temperature of the painted surface. Thus, the heater will possibly overheat the area and scorch the paint, or not heat the part enough and the paint will not be cured.
3. The heater head distance from the product is important. If the heater head is too far away, the product will not reach cure temperature and will run indefinitely trying to get to temperature. If the heater head is too close "striping" may occur. The recommended distance of the heater face to the product is 8 -12". The heater should be as parallel as possible to the product surface, which helps maintain uniform heating over the heated area.
4. Before heating a repair, determine if there are any types of reinforcements or extra thicknesses of metal in the area to be cured. These areas will heat at different rates and not achieve the same temperature as the single thickness metals without reinforcements. Aim the heat sensor on, or near, the multiple thickness or reinforced areas so they will be fully cured.
5. Once the cycle has started, do not move the unit. This will cause the temperature sensor to "see" a different area, which may be cooler. If the temperature drops 18°F, it will reset the timer and run another complete cycle. To help the unit's stability, be sure to lock the casters on the base of the arm after positioning the heater to lock it in place.
6. Check the control panel 3 to 5 minutes into the cycle. See if the temperature has risen to set point and if the timer has started. If it hasn't, determine the problem and correct it. If there is a problem with the position or setup of the arm where it cannot achieve the set point temperature, the timer will not turn on. The heater will run at full intensity indefinitely.
7. To achieve a full cure on a repair area, including overspray, the "effective cure area" of the heater must be considered. The "effective cure area" of the rectangular shaped heater heads is an oval shape that is just slightly smaller than the heater head. A general rule for the "effective cure area" dimensions are 1" in from the sides and end covers of the heater head, which creates the outer boundaries of the oval. When main and auxiliary heater heads are used together, add the two areas together.

Heat Masking

1. Any heat sensitive materials or surfaces (including plastic, rubber, trim, pin stripes, decals, light lenses, mirrors, door handles, interior materials, etc.) in the heating area must be masked or removed during the heating cycle. High temperature/reflective masking material approved for this type of application is required.
2. When curing small areas, it is not recommended to use heat masking around the area except to cover heat sensitive materials. The heat sensor "sees" an area approximately 1" in diameter, a heating area that is 1.5" or smaller could result in a false reading if the heat sensor is reading the masking.

Positioning / Set-Up of Heater Head Instructions

Positioning / Set-Up of an arm on flat surfaces (doors, hood, roofs, trunk lids, etc.)

1. Follow any of the instructions previously mentioned in the precautions and instructions section.
2. Always position heaters parallel and 8 to 12" from the surface.
3. Aim the positioning beam on spot being repaired; make sure that the beam is not aimed at heat sensitive materials.
4. Engage caster locks.
5. Recheck heat sensor aim with the positioning beam.
6. Set the temperature and time settings.
7. Start heat cycle.
8. Approximately 3-5 minutes after start, check that the temperature is at set point and the timer has started.
9. When the timer and the heater lamps shut off, the cycle is complete and ready for the next repair.
10. Press the E-stop button on unit when cycle has completed before moving unit to next repair or in to storage position.

Positioning / Set-Up of a heater on a curved or contoured surfaces (fender, hood, roof, trunk corners)

1. Follow any of the instructions previously mentioned in the precautions and instructions section.
2. Always position heaters parallel and 8 to 12" from the surface. Adjust the A and B heaters to the contour of the curve, with the most direct heat radiation in the area of the repair.
3. Aim the positioning beam on spot being repaired; make sure that the beam is not aimed at heat sensitive materials.
4. Engage caster lock.
5. Recheck heat sensor aim with the positioning beam.
6. Set the temperature and time settings.
7. Start heat cycle.
8. Approximately 3-5 minutes after start, check that the temperature is at set point and the timer has started.
9. When the timer and the heater lamps shut off, the cycle is complete and ready for the next repair.
10. Press the E-stop button on unit when cycle has completed before moving unit to next repair or in to storage position.

Positioning/Set-Up of an arm on roof posts (heavy reinforcements/multiple metal thickness)

1. Follow any of the instructions previously mentioned in the precautions and instructions section.
2. Position heaters parallel to the surface, the length of the heater along the length of the roof post. Do not put the heater 90° to the post, unless the repair area is very small. The heater should be about 8" from the surface for the heavy reinforcement in the posts.
3. Aim the positioning beam on spot being repaired; make sure that the beam is not aimed at heat sensitive materials. The post is very narrow, so carefully position the heat sensor where it will "see" the post.
4. Engage caster lock.
5. Recheck heat sensor aim with the positioning beam.
6. Set the temperature and time settings.
7. Start heat cycle.
8. Approximately 3-5 minutes after start, check that the temperature is at set point and the timer has started.
9. When the timer and the heater lamps shut off, the cycle is complete and ready for the next repair.
10. Press the E-stop button on unit when cycle has completed before moving unit to next repair or in to storage position.

Positioning/Set-Up of an arm on rocker panels (heavy reinforcements/multiple metal thickness)

1. Follow any of the instructions previously mentioned in the precautions and instructions section.
2. Position heaters parallel to the surface, the length of the heater along the length of the rocker panel. If there is an auxiliary heater head, use both heaters and bend them at about a 135° angle to focus more direct heat around the curve of the rocker panel. The heater should be spaced about 8" from the surface for the heavy reinforcement in the rocker panel.
3. Aim the positioning beam on spot being repaired; make sure that the beam is not aimed at heat sensitive materials
4. Engage caster lock.
5. Recheck heat sensor aim with the positioning beam.
6. Set the temperature and time settings.
7. Start heat cycle.
8. Approximately 3-5 minutes after start, check that the temperature is at set point and the timer has started.
9. When the timer and the heater lamps shut off, the cycle is complete and ready for the next repair.
10. Press the E-stop button on unit when cycle has completed before moving unit to next repair or in to storage position.

Yellow Pendant (for overhead arm movement)

The yellow pendant has a button labeled “Beam On” and “Start”. Toggling the “Beam on” activates the position beam and toggling the start button will initiate the heating cycle. Refer to “Setting the Temperature Controller Parameters” in the Operating Instructions for further instructions.

The controller has the following programmed features which allow the operator some flexibility on running heating cycles:

1. While running a cycle without a second ramp set up in the controller, operator may toggle the start button a second time resulting in bypassing the ramp feature.
2. While running a cycle with a second ramp set up in the controller, operator may toggle the start button a second time resulting in bypassing both ramps and going directly to second cure temperature without ramping feature.
3. Pushing the E-stop button will stop the current heating cycle.

NOTE: These are procedures that give reliable results for most repairs. Unusual or complex repairs might need modified procedures. Contact BGK service for assistance.

6. Maintenance

The AutoCure™6000 will require some basic maintenance when used on a regular basis. Failure to do so may degrade the performance of the unit.

Disconnect main power at the source before performing any maintenance procedures.

Actuator

1. Periodically check clevis ends for wear, cracks or distortion.
2. Periodically check the shoulder bolt/nut and 3/8" diameter rod for excessive wear.
3. Periodically apply a few drops of oil at these pivot points.

Pivot Points

1. Single head units have three (3) castle nut/spring combinations and two (2) shoulder bolts with Nylock nuts. If pivot points become loose, heater positioning will not be maintained. Check these points monthly.
2. Dual head units have seven (7) castle nut/spring combinations and two (2) shoulder bolts with Nylock nuts. If pivot points become loose, heater positioning will not be maintained. Check these points monthly.
3. To adjust spring tension; remove cotter pin, tighten castle nut (usually one or two notches) and replace cotter pin through bolt.

Lamps, Reflectors and Heat Sensor (Pyrometer) Lens

1. Clean with soft cloth and alcohol monthly. Heat sensor accuracy is dependent on a clean lens.

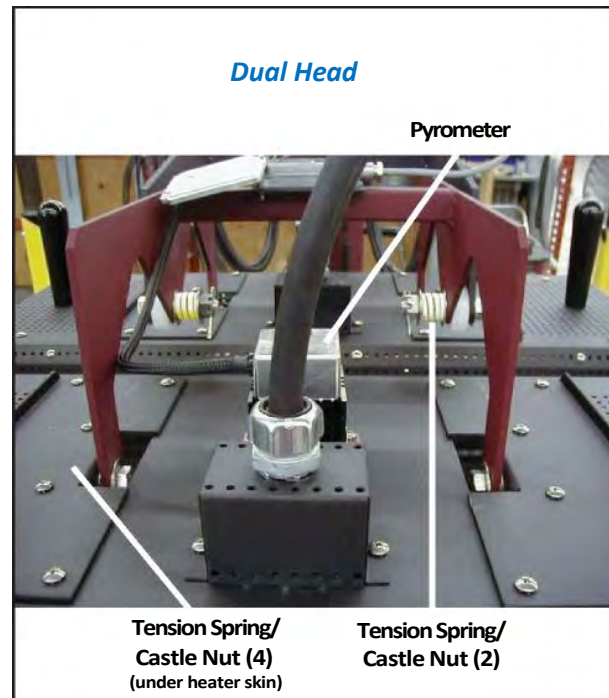
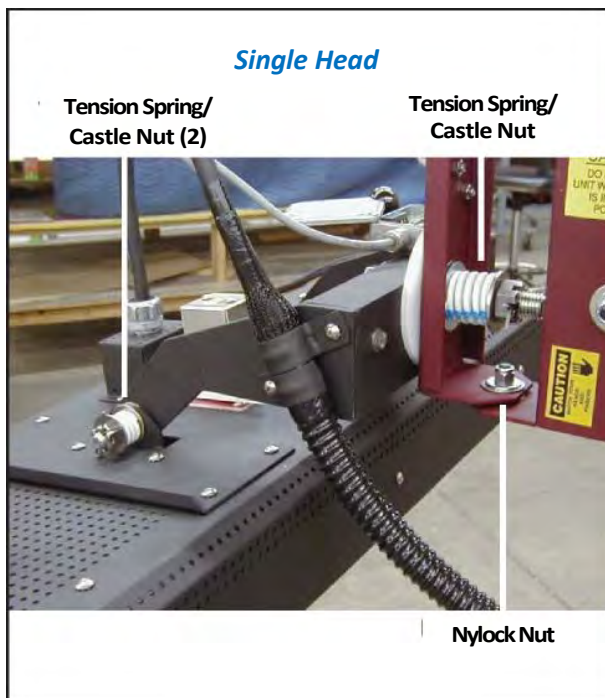

7. Troubleshooting Guide

Heater Power Problems

Problem

Heater lamps come on immediately when disconnect is closed.

Possible Cause and Corrective Action

- With power OFF, measure the resistance from the lamp wires to ground. The measurement should be more than 100 K ohms. If it is less than 100 K, check the lamp wiring and heater head for shorts to ground. Check for a bad firing circuit board or a shorted SCR by: exchanging the firing circuit board with one from a known good control. Does the problem follow the firing circuit board or does it stay with the SCR – replace the defective component.
- Contactor held closed – failed ON. Replace the contactor.

Problem

Heater lamps do not come on.

Possible Cause and Corrective Action

- Is the Power On/Off button illuminated, is the temperature controller on? - Check that incoming line power is present; transformer fuses, primary and secondary are good.
- Do the contactors energize when the Cycle Start button is pressed? – Check for loose wires associated with the contactors, change the temperature controller.
- Check that the set point (bottom display) is higher than the process temperature (top display).
- Are the line fuses in front of the contactors good – check voltage on the load side of the fuses or remove the fuses and check with an ohmmeter.
 - Is the green LED on the firing circuit lit? – Check that the firing circuit has 24 vac, with an ammeter check that the 4-20ma input signal is present from the temperature controller. If the 4-20ma signal is not present, see the section “No Output Signal from Temperature Controller”.
 - Do any of the zones function? – If the above points have been checked, confirm that there is a complete circuit through the lamps and all wiring is tight – change the SCR.
- Are all zones dead? – Zone A should function regardless of the zone switch setting, there is only one firing circuit for all zones - change the firing circuit

Temperature Controller Problems

Problem

Temperature controller has no display.

Possible Cause and Corrective Action

Check the supply voltage (24 VAC) to the unit at terminals 11 and 12. If voltage is present, replace the controller. If voltage is not present, check source of power (fuses, transformers, wiring, etc.)

Problem

No output signal from temperature controller.

Possible Cause and Corrective Action

- Check that the set point (bottom display) is higher than the process temperature (top display).
- Check the 0-5v input to the temperature controller at pins 9 & 10. If the 0-5v signal is not present, confirm that the Raytek pyrometer is functioning.
- Is the LCD display lit? If not, check that the Raytek input power (12 vdc) is present, check that the power supply board is supplying 12 vdc (TB 4) – replace the temperature controller, Raytek, or the power supply board.

Problem

Temperature controller output signal is present, but heater lamps do not come on.

Possible Cause and Corrective Action

Possible defective power controller firing circuit board and/or SCR. Check for a bad firing circuit board or SCR by exchanging the firing circuit board with one from a known good control. Does the problem follow the firing circuit board or does it stay with the SCR – replace the defective component.

Temperature Problems

Problem

The heater reaches set-point temperature, but the paint isn't cured properly or is darkened, or the heater does not reach set-point temperature.

Possible Cause and Corrective Action

- Read the instructions in the manual on how to position and run the heater.
- Clean the temperature sensor lens as described in maintenance section.
- The optical pyrometer is not seeing the surface of the object being heated. The pyrometer has about a 1-inch diameter field of view on the objects' surface. Position the heater head with the pyrometer so it sees the surface being heated. Make sure the pyrometer is not seeing parts of a window, wheel well, tape, masking, etc.

Problem

The temperature display jumps up or down many degrees within a second.

Possible Cause and Corrective Action

- Check for loose connections on the heat sensor (pyrometer) wiring.
- While the heater is running at temperature, gently wiggle the pyrometer cable and have someone watch for sudden temperature changes. If this happens – replace the cable.

Problem

Positioning Beam does not work

Possible Cause and Corrective Action

Check that the power supply board is supplying approximately 3.25 vdc (TB 3). Check that the wires are secure on the power supply board and on the push button. Open the cover on the heat sink assembly on the back of the heater and retest for the 3.25 v. If the power supply is functioning and there is no voltage at the heat sink assembly, open the Raytek pyrometer and test for the voltage (the 2 wire nuts) – replace the Positioning Beam.

8. TEMPERATURE CONTROLLER ERROR CODES

<u>Display</u>	<u>Problem</u>	<u>Actions</u>
Err.H	Open Sensor	Check sensor,wiring, and input
Err.L	Reversed Sensor	Check Sensor polarity
LPbr	Loop Break	Correct problem and Reset controller
0100	Checksum Error	Press Any Key to perform a soft reset and reinitialize controller
0101	RAM Error	
0202	Defaults Loaded	
0303	EEPROM Write Failure	
3865	Power Fail Resume Feature Disabled	No further resume actions available
36 Plus other 2 digit code	Unexpected or invalid interrupt	Reset Controller

Ramp/ Soak Errors

02= Recipe Empty (i.e. no non-zero ramp times)

05= Insufficient Setpoint - Process Value Deviation

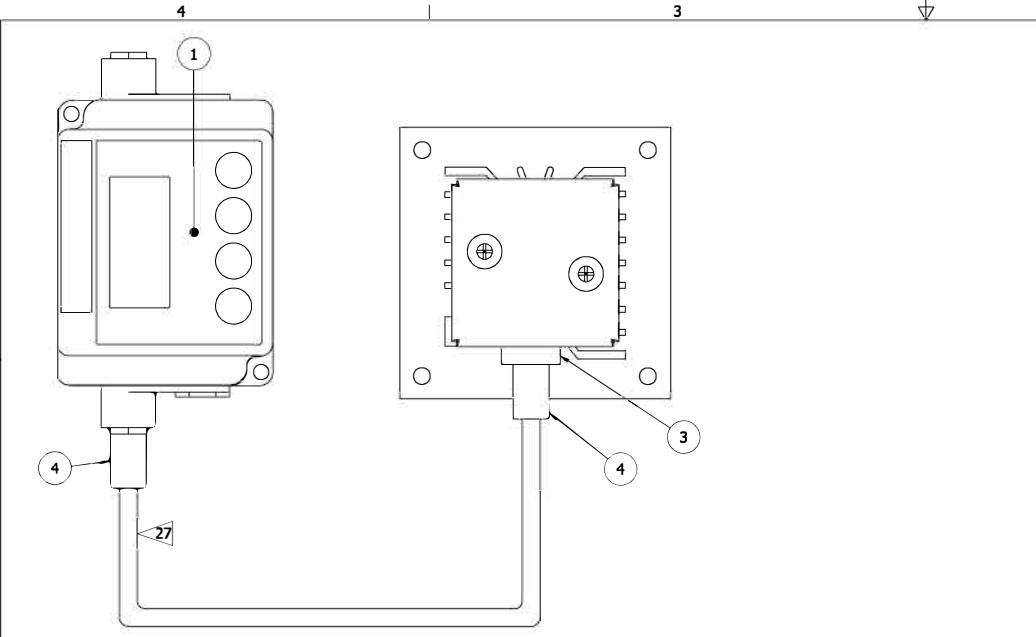

TOP VIEW

PARTS LIST			
ITEM	QTY	PART NUMBER	DESCRIPTION
1	1	42936	PYROMETER SENSOR
3	1	AC-200026	PYROMETER WIRE CLIP
4	2" x 2	TR-SSEM-283	SHRINK TUBING
5			
8	1	AC-65427	LASER
9	1	AC-61229	PLATE INTERMEDIATE
10	1	AC-61228	INSULATOR PYROMETER
11	1	AC-61227	MOUNT INSULATOR
12	1	AC-61232	HOUSING PYROMETER
13	1	AC-61230	COVER PYROMETER
14	2	AC-200099-3	SCREW MACH FL HD SLOT 8-32 X 2.750
15	2	AC-200032	STANDOFF HEX 8-32 X .750
16	2	AC-13938	WASHER LOCK EXTERNAL
17	2	AC-10142	SCREW MACH TRUSS PH 8-32 X 3/8
18	1	AC-200088	CAUTION LABEL
19	2	AC-200031	FEMALE CONNECTOR
20	2	AC-200030	MALE WIRE CONNECTOR
21	2	AC-200033	CABLE SLEEVE
22	28"	AC-200052-4 (G)	MESH
23	35"	AC-200077	BROWN WIRE
24	35"	AC-200078	GREEN WIRE
25	2	72591-01	WHITE CABLE SLEEVE
26	2	AC-200034	WIRE NUTS
27	1	AC-200026	STRAIGHT-THROUGH STRAIN RELIEF

NOTES:

- OPEN HOUSING AND LOOSEN 4 TERMINALS TO REMOVE PYROMETER.
- LOOSEN NUT AND REMOVE NUT, GROMMET, AND 3 WASHERS. DISCARD ONE WASHER.
- WRAP 3.3" COPPER TAPE AROUND PYROMETER TO ENSURE RUNNING FIT (USE AC-200198). WRAP 4.5" OF TAPE AROUND LASER (AC-65427) (H)
- APPLY THERMAL JOINT COMPOUND USING APPLICATOR AND SPREAD ACROSS ENTIRE CIRCUMFERENCE (USE AC-200199).
- CENTER PYROMETER AND LASER TO THROUGH HOLES WHILE ASSEMBLING PLATES.
- INSTALL LASER FACE FLUSH WITH HEAT SINK (H)
- STRIP BACK 5/16" MINIMUM.
- ASSEMBLE WITH TOOL HEYCO NO. 29.
- ASSEMBLE WITH WEIDEMUELLER 901250. (H)
- ASSEMBLE WITH KLINE CRIMPER 1005.
- STRIP BACK 1/4" MINIMUM.
- USE TOOL TO INSTALL TERMINALS ONTO WIRES.
- INSTALL FLEXIBLE CONDUIT AROUND WIRES.
- INSTALL SHRINK WRAP.
- INSTALL CABLE THROUGH PYROMETER HOUSING.
- INSTALL GROMMET OVER SHRINK WRAP INTO PYROMETER HOUSING.
- AC-200034 REQUIRED FOR WIRE COVER ON AC-42936 2 PLACES. LEAVE LOOSE IN HOUSING. SEE SHEET 3. (26)

REVISION HISTORY				
REV	DESCRIPTION	DCO	DATE	APPROVED
B	UPDATED BOM	18943	8/16/12	RAN
C	ADDED NEW PYROMETER	19524	8/16/13	RAN
D	CHANGED 6655-01 TO AC-200077, 6655-05 TO AC-200078	20079	1/21/15	RAN
E	CHANGED QTY OF #18 FROM 2 TO 1 AND REMOVED REF QTYS ON PAGE 2	20168	3/13/15	RN
F	MOVED NOTES 1-2,4-7. REVISED NOTE 8. REMOVED NOTES 2,9,10. ADDED 18 ASSEMBLY NOTES. RENUMBERED NOTES. REMOVED FRONT AND BOTTOM VIEW FROM SHEET 1	20425	8/31/2015	EAO
F+	CORRECT REVISION	20482	10/20/2015	EAO
G	WAS AC-200052-1	20832	5/26/16	EAO
H	ADDED NOTE FOR MOUNT FLUSH, RENUMBERED FOLLOWING NOTES, WAS SEED CRIMPER, REVERSE DIRECTION OF CONNECTORS ON BLACK/ BROWN WIRE SHEET 4, ADD LENGTH OF TAPE TO NOTE 6	30856	1/11/2017	EAO

NOTES (CONT'D):

- APPLY SHRINK TUBING ONTO MESH AFTER TRIMMING WIRES TO SAME LENGTH AS MESH. SEE SHEET 4 OF 4 FOR LOCATION.
- MOVE NUT UP ONTO SHRINK TUBING TO ALLOW FOR GROMMET INSTALLATION.
- CUT 1/8" X 1/8" V-NOTCH TO SHRINK TUBE.
- INSTALL GROMMET ONTO SHRINK TUBE USING BULLET TOOL OR PLIERS.
- INSTALL 2 WASHERS AS SHOWN - SEE SHEET 3.
- INSTALL NUT ASSEMBLY.
- AFTER INSTALLING WIRES INTO TERMINAL BLOCK, PERFORM TWO FINGER PULL TEST.
- AFTER ASSEMBLY, CONNECTION TO HOUSING MUST PASS UL STANDARD 3LB DROP TEST.

JOB NO	QTY	REL BY	ENG REL	SHOP	VENDER	P.O.NO	PROD REL	DUE
BGK FINISHING SYSTEMS								
DRAWN:	SCALE:	TOLERANCES		THIS MATERIAL IS THE PROPERTY OF BGK FINISHING SYSTEMS IT MUST NOT BE COPIED OR ITS CONTENTS DISCLOSED WITHOUT AUTHORIZATION © 2004 BGK FINISHING SYSTEMS				
DATE:	JOB NO:	2 PLACE ± .030	FRACT. ± .1/32	PYROMETER				
MATERIAL:		3 PLACE ± .030	ANGULAR ±					
FINISH:	NEXT ASSY:	PART NO:	DRAWING NO:	REV:	SHEET:			
			AC-61231	H	1	OF 4		

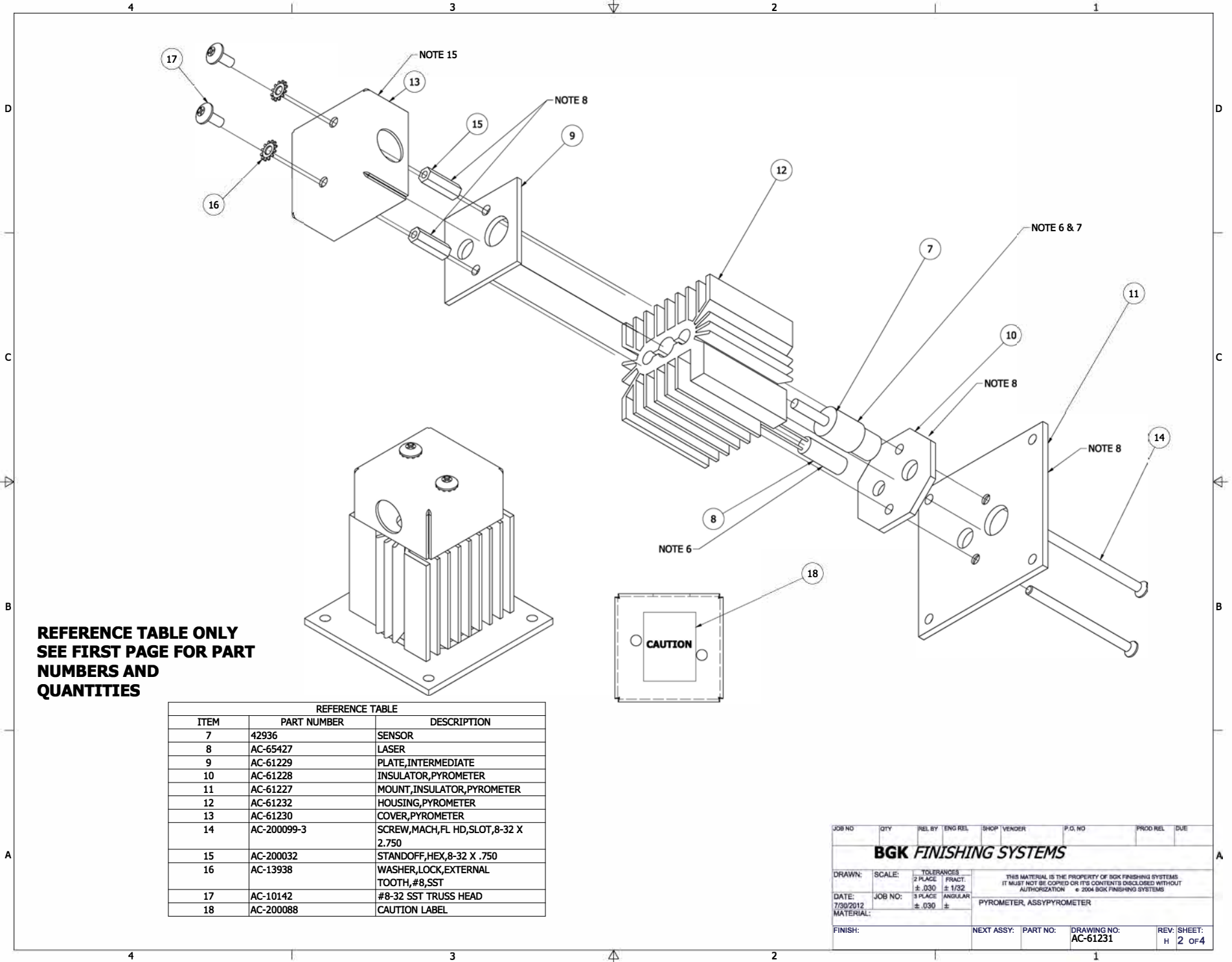

**REFERENCE TABLE ONLY
SEE FIRST PAGE FOR PART
NUMBERS AND
QUANTITIES**

REFERENCE TABLE		
ITEM	PART NUMBER	DESCRIPTION
7	42936	SENSOR
8	AC-65427	LASER
9	AC-61229	PLATE,INTERMEDIATE
10	AC-61228	INSULATOR,PYROMETER
11	AC-61227	MOUNT,INSULATOR,PYROMETER
12	AC-61232	HOUSING,PYROMETER
13	AC-61230	COVER,PYROMETER
14	AC-200099-3	SCREW,MACH,FL HD,SLOT,8-32 X 2.750
15	AC-200032	STANDOFF,HEX,8-32 X .750
16	AC-13938	WASHER,LOCK,EXTERNAL TOOTH,#8,SST
17	AC-10142	#8-32 SST TRUSS HEAD
18	AC-200088	CAUTION LABEL

JOB NO	QTY	REL BY	ENG REL	SHOP VENDOR	P.O. NO	PROD REL	DUE
BGK FINISHING SYSTEMS							
DRAWN:	SCALE:	TOLERANCES		THIS MATERIAL IS THE PROPERTY OF BGK FINISHING SYSTEMS IT MUST NOT BE COPIED OR ITS CONTENTS DISCLOSED WITHOUT AUTHORIZATION © 2004 BGK FINISHING SYSTEMS			
DATE:	JOB NO:	2 PLACE	FRACT:	PYROMETER, ASSYPYROMETER			
MATERIAL:		3 PLACE	ANGULAR				
FINISH:	NEXT ASSY:	PART NO:	DRAWING NO:	REV:	SHEET:		
			AC-61231	H	2 OF 4		

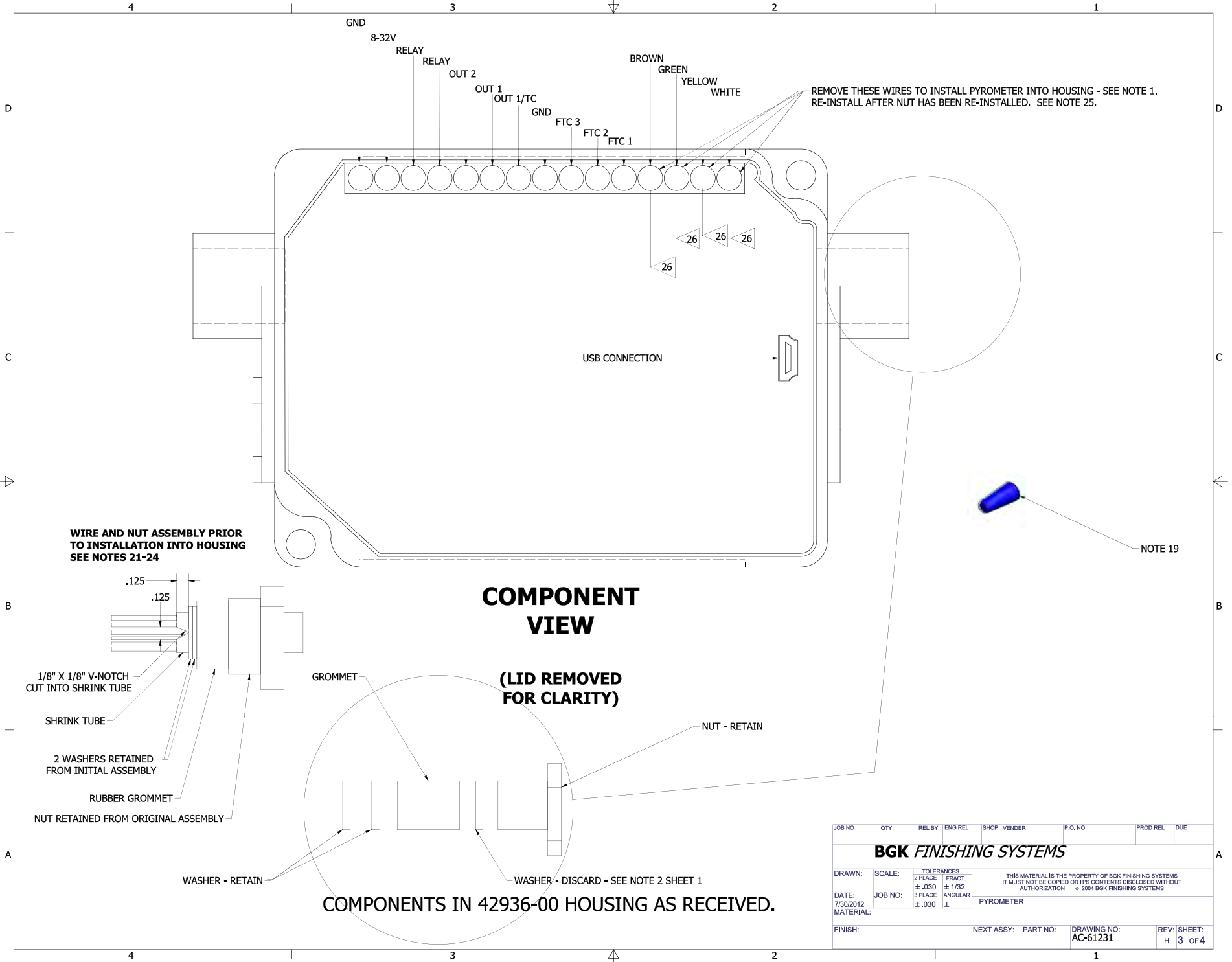

**WIRE AND NUT ASSEMBLY PRIOR TO INSTALLATION INTO HOUSING
SEE NOTES 21-24**

COMPONENT VIEW

(LID REMOVED FOR CLARITY)

COMPONENTS IN 42936-00 HOUSING AS RECEIVED.

JOB NO	QTY	REL BY	ENG REL	SHOP	VENDOR	P.O. NO	PROD REL	DUE
BGK FINISHING SYSTEMS								
DRAWN:	SCALE:	TOLERANCES		THIS MATERIAL IS THE PROPERTY OF BGK FINISHING SYSTEMS IT MUST NOT BE COPIED OR ITS CONTENTS DISCLOSED WITHOUT AUTHORIZATION © 2004 BGK FINISHING SYSTEMS				
DATE:	JOB NO:	2 PLACE	FRACT.	PYROMETER				
MATERIAL:		± .030	± 1/32	3 PLACE	ANGULAR			
		± .030	±					
FINISH:	NEXT ASSY:	PART NO:	DRAWING NO:	REV:	SHEET:			
			AC-61231	H	3	OF 4		

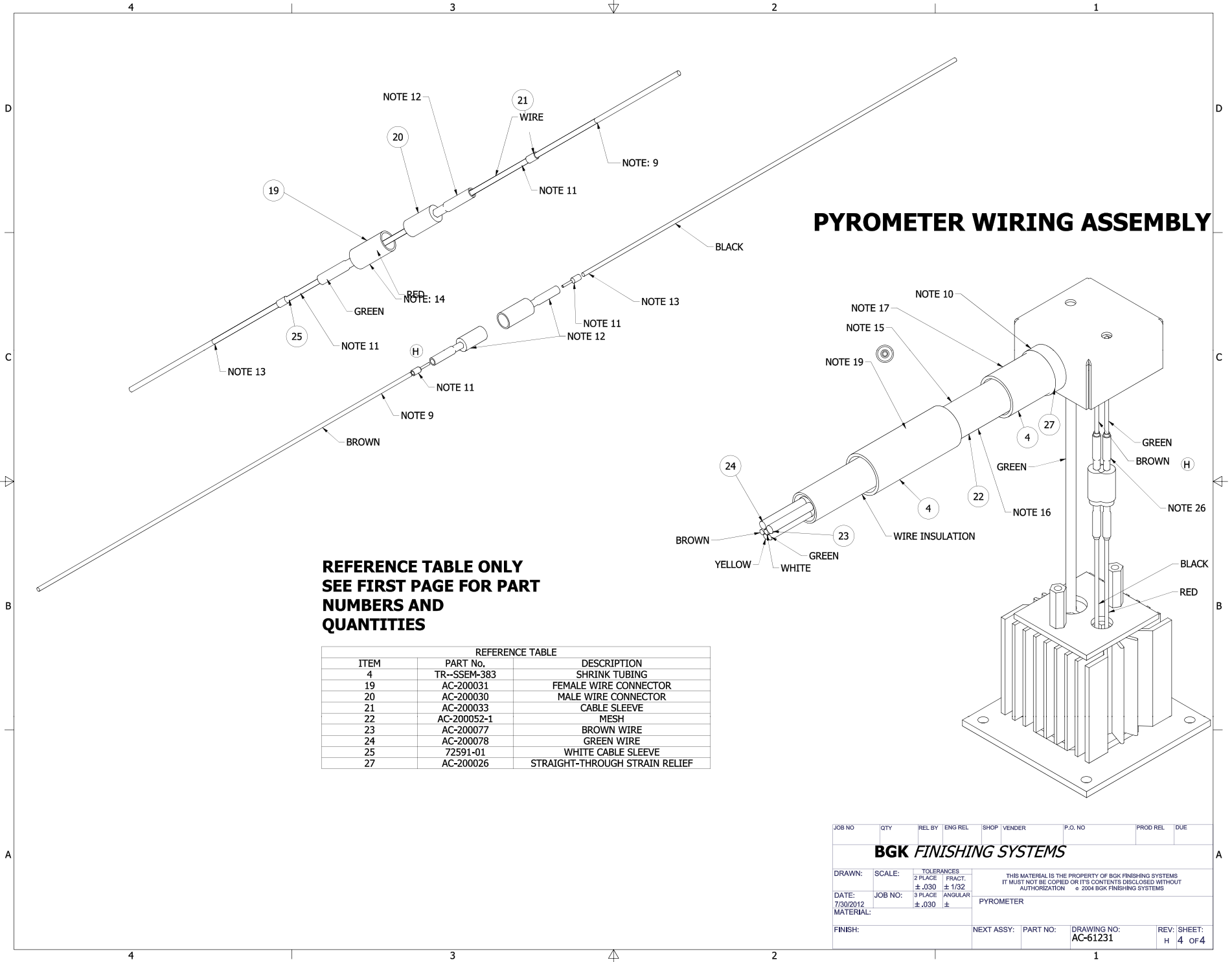

PYROMETER WIRING ASSEMBLY

**REFERENCE TABLE ONLY
SEE FIRST PAGE FOR PART
NUMBERS AND
QUANTITIES**

REFERENCE TABLE		
ITEM	PART No.	DESCRIPTION
4	TR--SSEM-383	SHRINK TUBING
19	AC-200031	FEMALE WIRE CONNECTOR
20	AC-200030	MALE WIRE CONNECTOR
21	AC-200033	CABLE SLEEVE
22	AC-200052-1	MESH
23	AC-200077	BROWN WIRE
24	AC-200078	GREEN WIRE
25	72591-01	WHITE CABLE SLEEVE
27	AC-200026	STRAIGHT-THROUGH STRAIN RELIEF

JOB NO	QTY	REL BY	ENG REL	SHOP	VENDOR	P.O. NO	PROD REL	DUE
BGK FINISHING SYSTEMS								
DRAWN:	SCALE:	TOLERANCES		THIS MATERIAL IS THE PROPERTY OF BGK FINISHING SYSTEMS IT MUST NOT BE COPIED OR ITS CONTENTS DISCLOSED WITHOUT AUTHORIZATION © 2004 BGK FINISHING SYSTEMS				
DATE:	JOB NO:	2 PLACE	FRACT.	PYROMETER				
MATERIAL:		± .030	± 1/32	3 PLACE	ANGULAR			
		± .030	±					
FINISH:	NEXT ASSY:	PART NO:	DRAWING NO:	REV:	SHEET:			
			AC-61231	H	4	OF 4		

10. SERVICE INSTRUCTIONS FOR PYROMETER

RAYTEK PYROMETER REPLACEMENT CALIBRATION VERIFICATION ON OVERHEAD OR PORTABLE REPAIR ARM USING A HAND HELD PYROMETER (Raytek MID Pyrometer with BGK Temperature Controller ONLY)

Purpose:

This procedure is to be completed to verify the temperature display is correct on the BGK temperature controller. Then the BGK “*Auto-Cure*” series repair arms will heat the painted spot repair to the correct temperatures to achieve the proper cure of the paint.

Equipment Required:

- Hand-held Infrared pyrometer in good working order with a current calibration label. Pyrometer with laser aiming is preferred.
- A good condition scrap painted door, fender, or test panel on which to perform the calibration is required. (White or light color is preferred).
- A #1 Phillips screwdriver.

RAYMID10LT Pyrometer Sensor manufactured by Raytek has been discontinued. It has been replaced by model number RAYMI3D10LTS. This Change affects the following Autocure units AC3, AC5, AC6 & AC7, and AC8.

Shown below are photos of the differences between sensors:

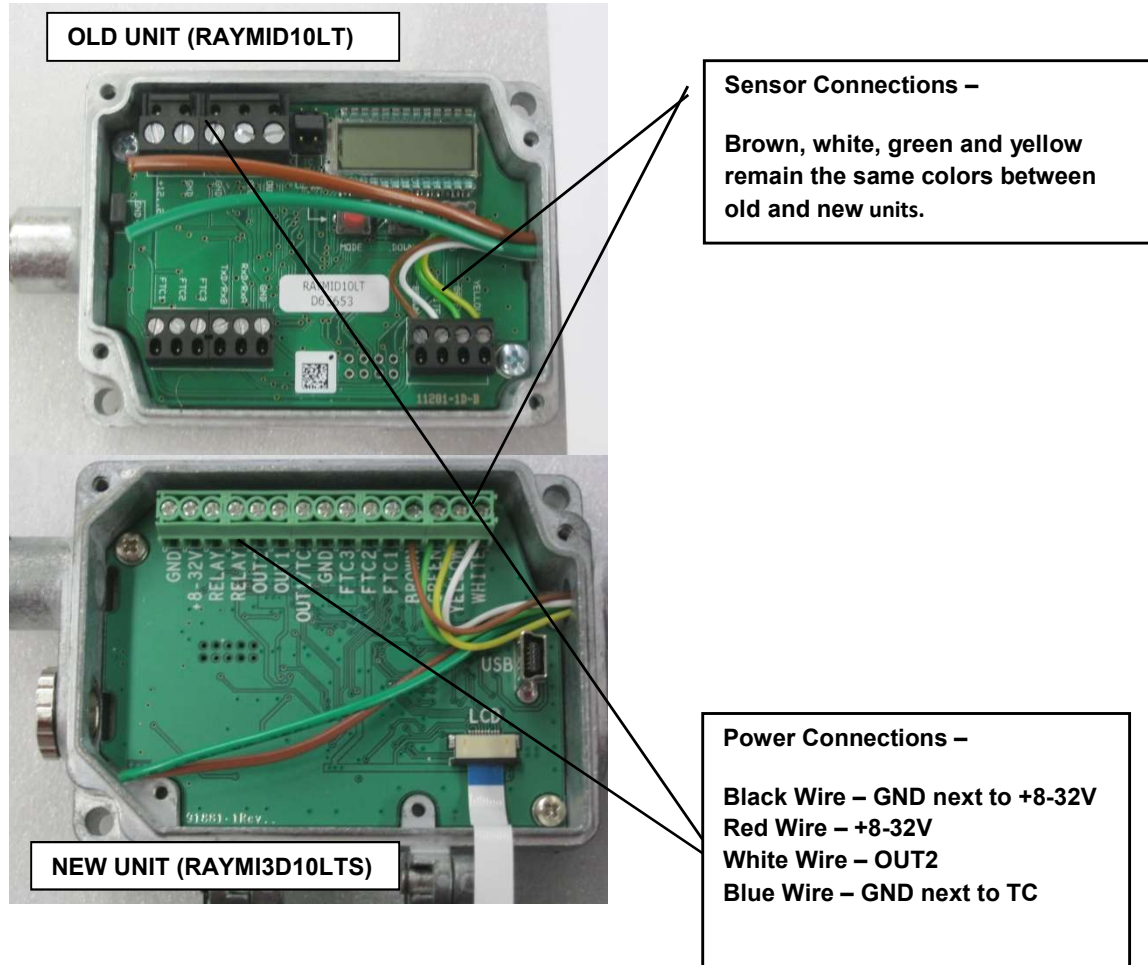

Additional modifications required – The AWG gage size of the laser wires that are typically connected inside the sensor with wire nuts. The wire gauge will be changing from 20 AWG to 22 AWG effective upon change over in February 2015.

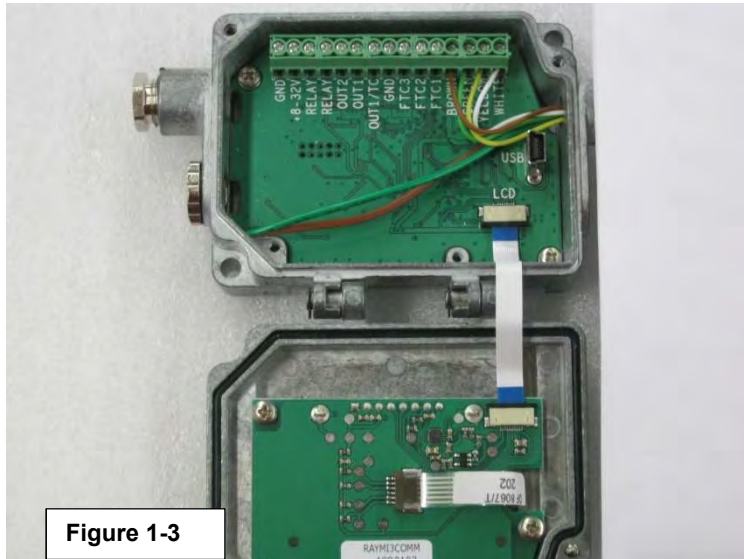

Figure 1-3

The new unit is hinged as shown in Figure 1-3.

Performance - the new sensor is equal, a direct replacement to the older unit. There is no change in emissivity or response time between units, they are equal.



Figure 1-4

The front cover over lay is solvent resistant. Figure 1-4.

Both the old and new **Raytek units are not rated for hazardous environment nor are they ATEX approved.**

They are **CE rated only.**

Replacement of New Pyrometer Sensor

1. Open Cover for Raytek Sensor, loosen and remove wire from terminals shown below.

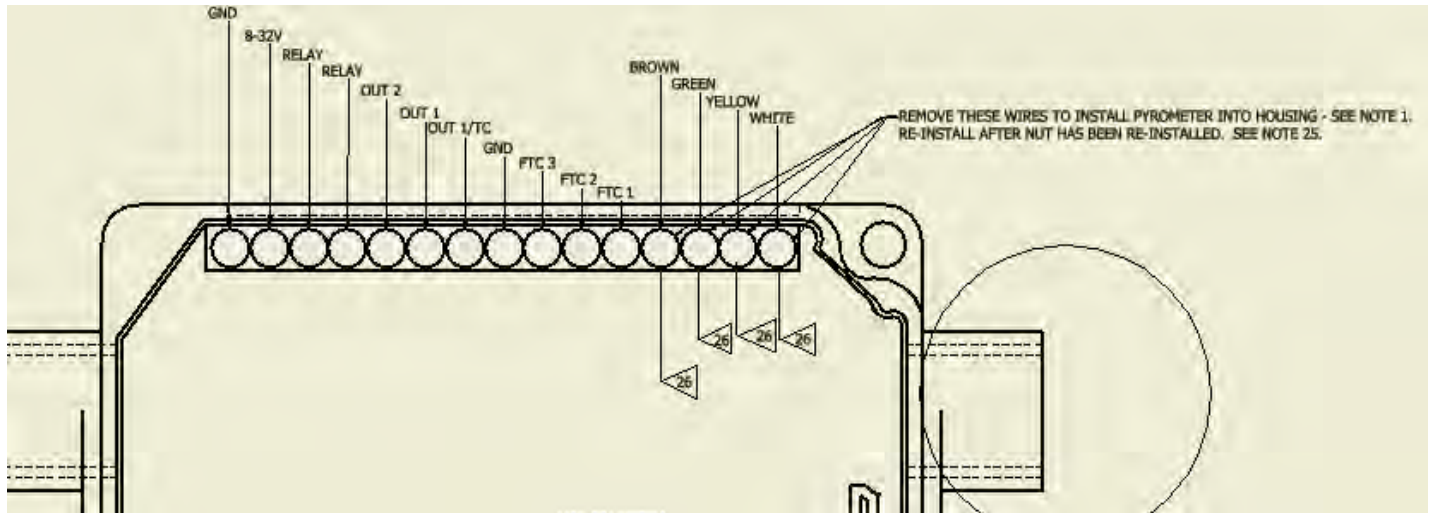

2. Undo wires from two wire nuts, as shown.

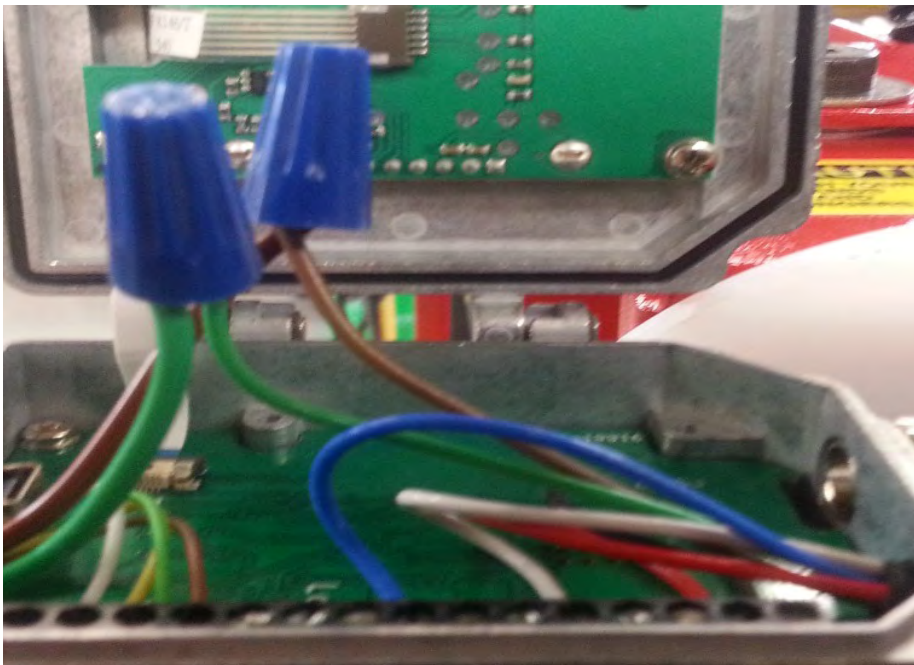

3. Loosen nut on pyrometer side, and remove wires from housing.
4. Open enclosure on top of heat sink, and isolate wires for laser (black/red leads)
5. Clip leads, leaving enough wire to strip and re-connect with crimp connections
6. Loosen and remove standoffs
7. Remove insulating plate
8. Remove heat sink, then remove pyrometer.

9. Install new pyrometer into heat sink, making sure to adjust fit using varnish tape wrapped on the outside.
10. Install heat sink onto lower insulators
11. Install intermediate plate
12. Crimp laser leads to leads in pyrometer bundle – red to green and brown to black.
13. Install standoffs
14. Replace cover and tighten nuts.
15. If new pyrometer, replace grommet into side of housing.
16. Reconnect leads in Raytek sensor housing using schematic in Step 1.
17. Reconnect wires in wire harness as shown above.

Replacement of Pyrometer Controller

1. Open Housing and loosen 4 terminals to remove pyrometer. Loosen 4 terminals to remove connection to AutoCure Arm as shown below.

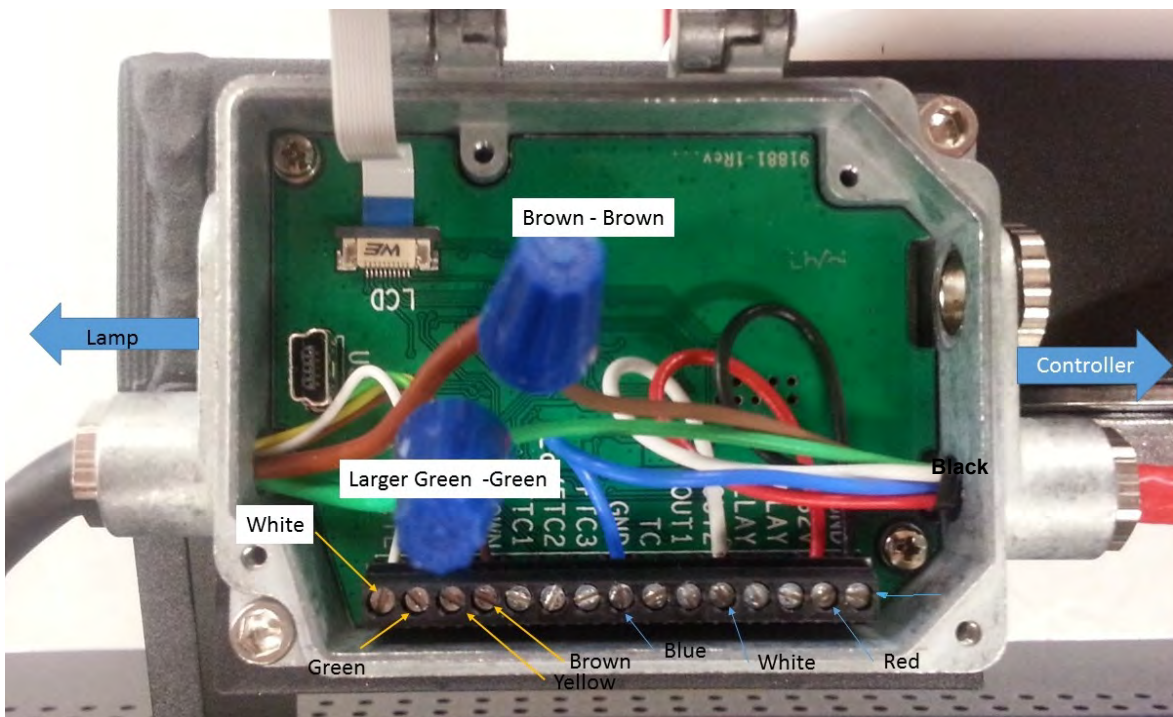

2. Open New Housing, and loosen 4 terminals as shown above to remove pyrometer.
3. Disconnect wires in wire nuts.
4. On New Housing, Loosen and remove nut, grommet, and three washers on thermocouple side. Loosen and remove nut and all washers on AC arm side.
5. Unmount housing and replace with new housing.
6. Install nut, grommet and 2 washers onto Thermocouple leads, as shown below.

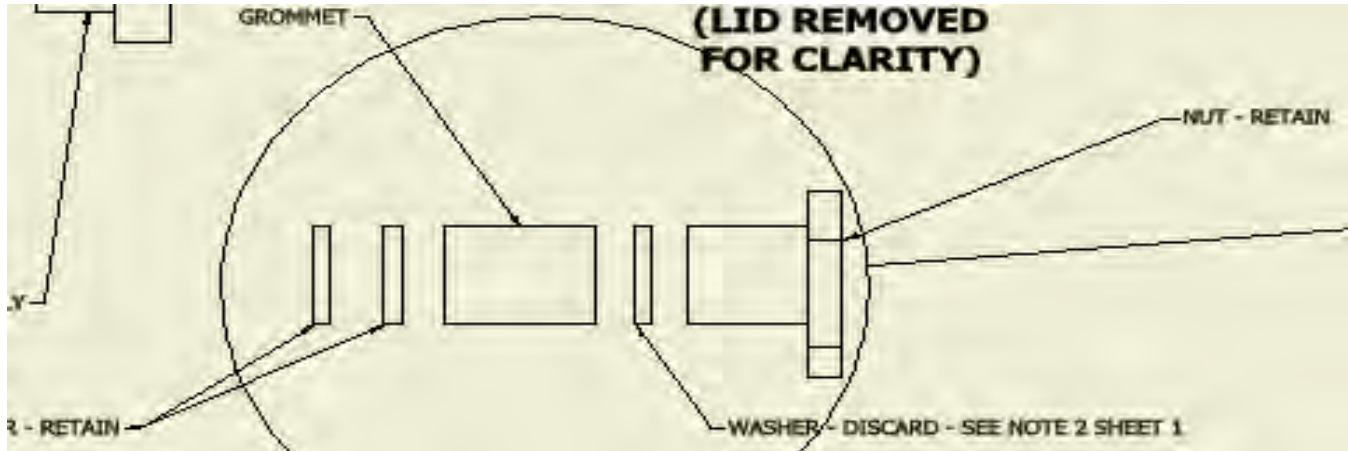

7. Once installed, insert leads for thermocouple into terminals indicated in Step 1.
8. Insert and tighten down to 20 Nm.
9. From AC arm, insert nut, AC-200104 Nylon washers and Grommet, similar to diagram in step 5.
10. Insert leads into terminals indicated in step 1. Reconnect leads into wire terminals.
11. Tighten down nut to 20 Nm.
12. Verify calibration per SI-B-11-02.1 (see next page).

Verification / Calibration Procedure

1. Position the good condition testing surface (door, fender, etc.) in front of the heater head. Adjust the heater head about 10" away from the painted test surface. (Approx. an open hand width.)

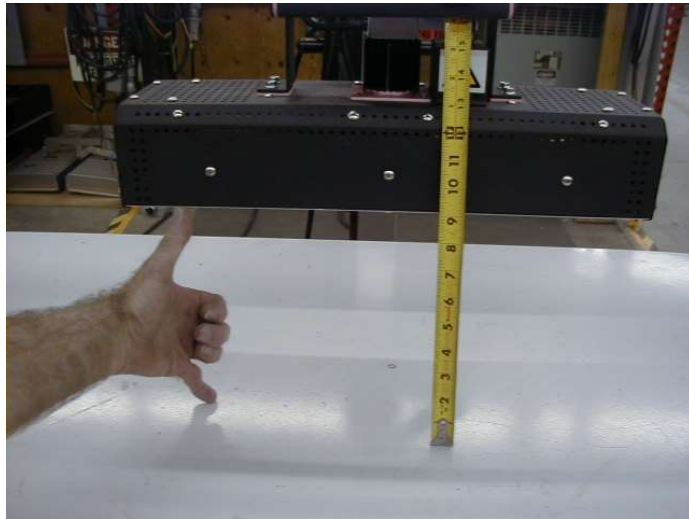

2. On the good condition, scrap painted testing surface with a pen, pencil or grease pen make a small "X" or dot where the surface is mainly flat and there are **NO** reinforcements or multiple thickness metals within about 12 inches of the mark.

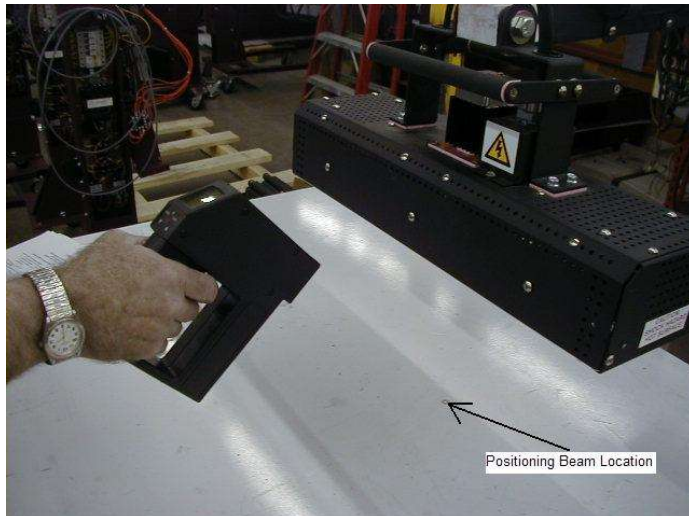

3. Then on the arm control panel, push the "Positioning Beam On" button. Locate the positioning beam (red dot) on the test surface on the "X" or dot you made above. Make sure you maintain the 10-inch gap between the test surface and the heater head. This dot is also the point where the hand-held pyrometer will be aimed during calibration to read the same area the arm pyrometer is reading (temperature reading area). Again, ensure the red dot is **not** aimed at areas with reinforcements or multiple thickness metals within about 12 inches of the dot.

Begin Verification / Calibration Cycle

1. Verify that the Ramp 1 and Ramp 2 (if used) cure temperatures (ct1 and ct2) settings are at the proper temperature set points used for the area.
2. Press the “Cycle Start” **button two times with in two seconds**.
Lamp cycle should begin with a ramp-up to the final cure ramp settings. They will be “rp1” set points on a single ramp setup and “rp2” on a dual ramp setup. (See figure A). The temperature set point will be displayed on the bottom display of the temperature controller. The upper display will alternate between “rp_” and the actual temperature feedback from the pyrometer.
After the “rp_” has completed the ramp and flashing, the hold cycle will begin with a constant temperature on the upper display at the “ct_” set point.



Using the handheld pyrometer, measure the temperature of the target about 1” to the right of the positioning beam spot. (Figure D). **Hold the hand-held pyrometer as close to 90° to the testing surface as possible by the edge of the heater head.** This is critical for an accurate and consistent reading.

3. ***Compare the handheld reading with the process temperature (upper display) on the temperature controller. If they are within 5 degrees, no further changes are required. If they are not, continue with doing the following calibration procedure.***

Verify “Lock” Status of Raytek Comm Module

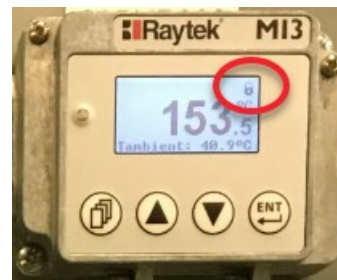
1. **Verify lock status on Raytek box** – Observe the display for a “Padlock” on the screen as shown. If the icon is displayed the unit is “Locked out” preventing any parameter changes. Complete steps below to “Unlock” the unit, otherwise continue with next section.







2. The unit can be unlocked by pressing the  button and the  button simultaneously for 3 seconds or alternatively by pressing the  button for 5 seconds.

Adjusting Raytek Calibration Procedure

1. **Verify correct settings on Raytek box** – Press the page button  until “BOX SETUP” is displayed.



OUT2 Mode

Using the arrow keys   until “OUT2 Mode” is displayed. Verify  setting for mode is 0-5V. If the setting is incorrect, press the enter button



and the setting should be highlighted. Press the arrows keys   until the correct settings is display, 0-5V. After settings is correct, press the enter button

 to save setting.

OUT2 Value

Using the arrow keys   until “OUT2 Value” is displayed. Verify the setting for mode is “Tobject”. If the





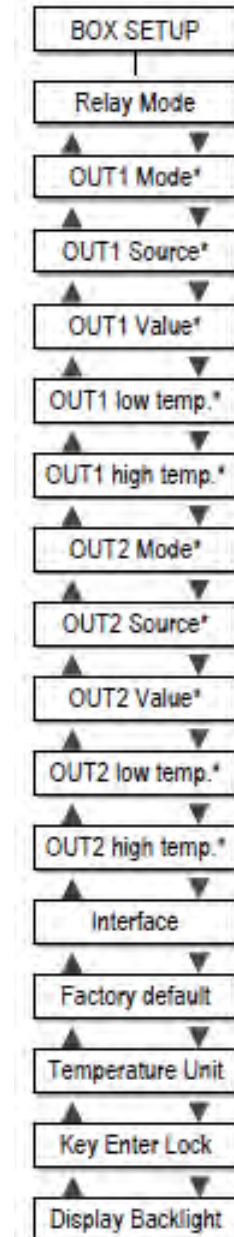

setting is incorrect, press the enter button  and the setting should be highlighted. Press the arrows keys

  until the correct settings is display, “Tobject”.

After settings is correct, press the enter button  to save setting.



Temperature Unit

Using the arrow keys   until "Temperature Unit" is displayed. Press the enter button  and the setting should be highlighted. Press the arrows keys   until the correct setting is displayed, °F or °C. After settings is correct, press the enter button  to save setting.



2. Position the testing surface (door, fender, etc.) in front of the heater head. Adjust the heater head about 10" away from the painted test surface. (Approx. an open hand width.)

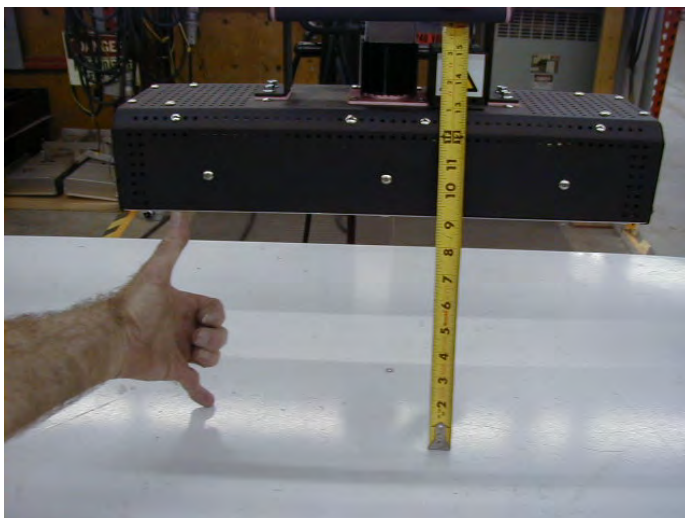

3. On the scrap painted testing surface with a pen, pencil or grease pen make a small “X” or dot where the surface is mainly flat and there are **NO** reinforcements or multiple thickness metals within about 12 inches of the mark.

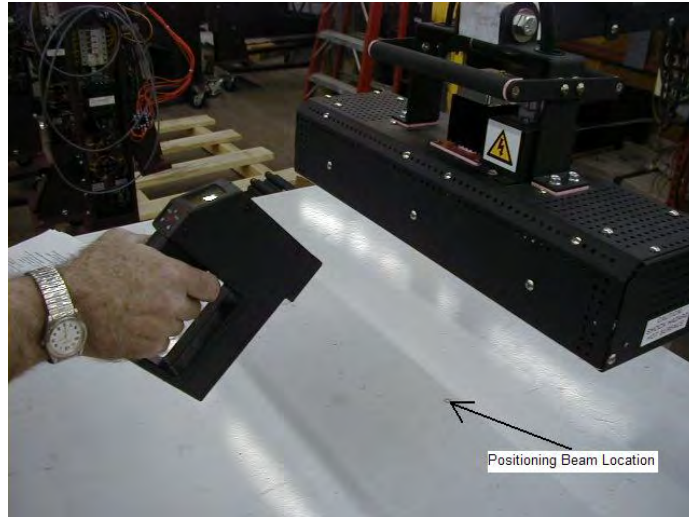

4. Then on the arm control panel, push the “Positioning Beam On” button. Locate the positioning beam (red dot) on the test surface on the “X” or dot you made above. Make sure you maintain the 10-inch gap between the test surface and the heater head. This dot is also the point where the hand-held pyrometer will be aimed during calibration to read the same area the arm pyrometer is reading (temperature reading area). Again, ensure the red dot is **not** aimed at areas with reinforcements or multiple thickness metals within about 12 inches of the dot.

Begin Calibration Cycle

1. Verify that the Ramp 1 and Ramp 2 (if used) cure temperatures (ct1 and ct2) settings are at the proper temperature set points used for the area.
2. Press the “Cycle Start” **button two times with in two seconds.**







Lamp cycle should begin with a ramp-up to the final cure ramp settings. They will be “rp1” set points on a single ramp setup and “rp2” on a dual ramp setup. (See figure A). The temperature set point will be displayed on the bottom display of the temperature controller. The upper display will alternate between “rp_” and the actual temperature feedback from the pyrometer.

After the “rp_” has completed the ramp and flashing, the hold cycle will begin with a constant temperature on the upper display at the “ct_” set point.





Using the handheld pyrometer, measure the temperature of the target about 1” to the right of the positioning beam spot. (Figure D). **Hold the hand-held pyrometer as close to 90° to the testing surface as possible by the edge of the heater head.** This is critical for an accurate and consistent reading.

Compare the handheld reading with the process temperature (upper display) on the temperature controller. If they are within 5 degrees, no further calibration is required. If they are not, continue with the calibration.

Calibration Adjustment

1. Depress the page button  until "BOX SETUP" is displayed. Press the arrow buttons   until "OUT2 high temp" is displayed. Press the enter button  to allow the temperature setting to be changed.









2. If the reading on the handheld pyrometer is higher than that of the process temperature on the temperature controller, decrease the temperature number using the down button . After adjusting the value press the enter button  to save the value.
3. If the reading on the handheld pyrometer is less than the process temperature on the temperature controller, increase the temperature number using the up button . After adjusting the value press the enter button  to save the value.
4. ***When you are within 5 degrees difference between the handheld pyrometer and the process temperature, no further calibration is required. Calibration is complete.***
5. Press the page button  until display returns to main screen.

“Lock” out the Comm Box

1. Press the page button  until “BOX SETUP” is displayed.

Key Enter Lock

2. Using the arrow keys   until “Key Enter Lock” is displayed. Verify the setting “YES”. If the setting is incorrect, press the enter button  and the setting should be highlighted. Press the arrows keys   until the correct settings “Yes” is displayed. After settings is correct, press the enter button  to save setting.

3. Verify the padlock is displayed as shown.

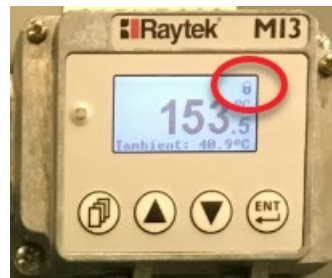

Procedure is completed.

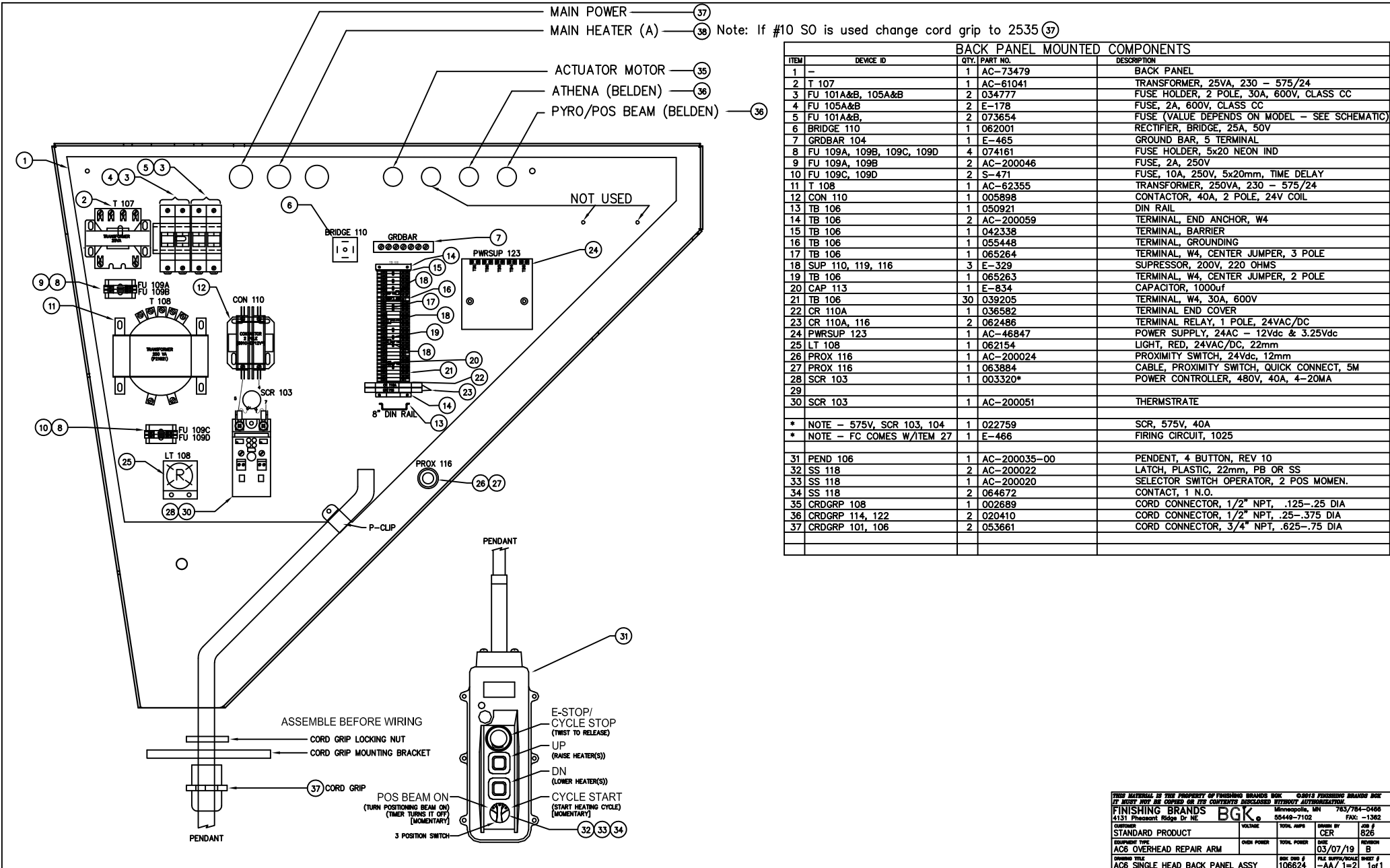

BACK PANEL MOUNTED COMPONENTS			
ITEM	DEVICE ID	QTY. PART NO.	DESCRIPTION
1	-	1 AC-73479	BACK PANEL
2	T 107	1 AC-61041	TRANSFORMER, 25VA, 230 - 575/24
3	FU 101A&B, 105A&B	2 034777	FUSE HOLDER, 2 POLE, 30A, 600V, CLASS CC
4	FU 105A&B	2 E-178	FUSE, 2A, 600V, CLASS CC
5	FU 101A&B,	2 073654	FUSE (VALUE DEPENDS ON MODEL - SEE SCHEMATIC)
6	BRIDGE 110	1 062001	RECTIFIER, BRIDGE, 25A, 50V
7	GRDBAR 104	1 E-465	GROUND BAR, 5 TERMINAL
8	FU 109A, 109B, 109C, 109D	4 074161	FUSE HOLDER, 5x20 NEON IND
9	FU 109A, 109B	2 AC-200046	FUSE, 2A, 250V
10	FU 109C, 109D	2 S-471	FUSE, 10A, 250V, 5x20mm, TIME DELAY
11	T 108	1 AC-62355	TRANSFORMER, 250VA, 230 - 575/24
12	CON 110	1 005898	CONTACTOR, 40A, 2 POLE, 24V COIL
13	TB 106	1 050921	DIN RAIL
14	TB 106	2 AC-200059	TERMINAL, END ANCHOR, W4
15	TB 106	1 042338	TERMINAL, BARRIER
16	TB 106	1 055448	TERMINAL, GROUNDING
17	TB 106	1 065264	TERMINAL, W4, CENTER JUMPER, 3 POLE
18	SUP 110, 119, 116	3 E-329	SUPPRESSOR, 200V, 220 OHMS
19	TB 106	1 065263	TERMINAL, W4, CENTER JUMPER, 2 POLE
20	CAP 113	1 E-834	CAPACITOR, 1000uF
21	TB 106	30 039205	TERMINAL, W4, 30A, 600V
22	CR 110A	1 036582	TERMINAL END COVER
23	CR 110A, 116	2 062486	TERMINAL RELAY, 1 POLE, 24VAC/DC
24	PWRSUP 123	1 AC-46847	POWER SUPPLY, 24AC - 12Vdc & 3.25Vdc
25	LT 108	1 062154	LIGHT, RED, 24VAC/DC, 22mm
26	PROX 116	1 AC-200024	PROXIMITY SWITCH, 24Vdc, 12mm
27	PROX 116	1 063884	CABLE, PROXIMITY SWITCH, QUICK CONNECT, 5M
28	SCR 103	1 003320*	POWER CONTROLLER, 480V, 40A, 4-20MA
29			
30	SCR 103	1 AC-200051	THERMSTRATE
* NOTE - 575V, SCR 103, 104		1 022759	SCR, 575V, 40A
* NOTE - FC COMES W/ITEM 27		1 E-466	FIRING CIRCUIT, 1025
31	PEND 106	1 AC-200035-00	PENDANT, 4 BUTTON, REV 10
32	SS 118	2 AC-200022	LATCH, PLASTIC, 22mm, PB OR SS
33	SS 118	1 AC-200020	SELECTOR SWITCH OPERATOR, 2 POS MOMEN.
34	SS 118	2 064672	CONTACT, 1 N.O.
35	CRDGRP 108	1 002689	CORD CONNECTOR, 1/2" NPT, .125-.25 DIA
36	CRDGRP 114, 122	2 020410	CORD CONNECTOR, 1/2" NPT, .25-.375 DIA
37	CRDGRP 101, 106	2 053661	CORD CONNECTOR, 3/4" NPT, .625-.75 DIA

COMPONENTS LOCATED ON THE ARM

1	INST 116	1	AC-74816-XXX-X-XXX TEMPERATURE CONTROLLER (See Spare Parts for Complete #)
---	----------	---	--

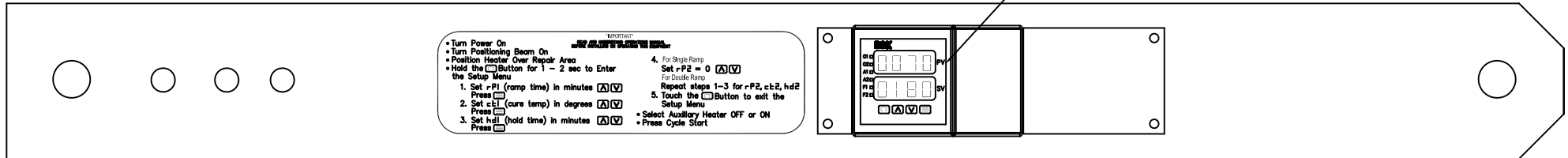

IMPORTANT!

- Turn Power On
- Turn Positioning Beam On
- Position Heater Over Repair Area
- Hold the Button for 1 - 2 sec to Enter the Setup Menu
- 1. Set rPI (ramp time) in minutes
- 2. Set cEI (cure temp) in degrees
- 3. Set hdi (hold time) in minutes
- 4. For Single Ramp Set rP2 = 0
- For Double-Ramp Repeat steps 1-3 for rP2, cE2, hd2
- 5. Touch the Button to exit the Setup Menu
- Select Auxiliary Heater OFF or ON
- Press Cycle Start

Parts List						
ITEM	QTY	TYPE	PART NUMBER	DESCRIPTION		
1	1	P	-	6" CUT DIN RAIL		
2	1	P	A8066CH	J-BOX,8X6X6		
3	1	P	A8P6	INNER PANEL,8X6		
4	3	P	AC-200058	AB IEC ONE CIRCUIT FEED THROUGH BLOCK		
5	2	P	AC-200059	AB END ANCHOR		
6	1	P	AC-200060	AB END BARRIER		
7	1	P	AC-200061	AB IEC ONE CURCUIT FEED THROUGH GND BLOCK		

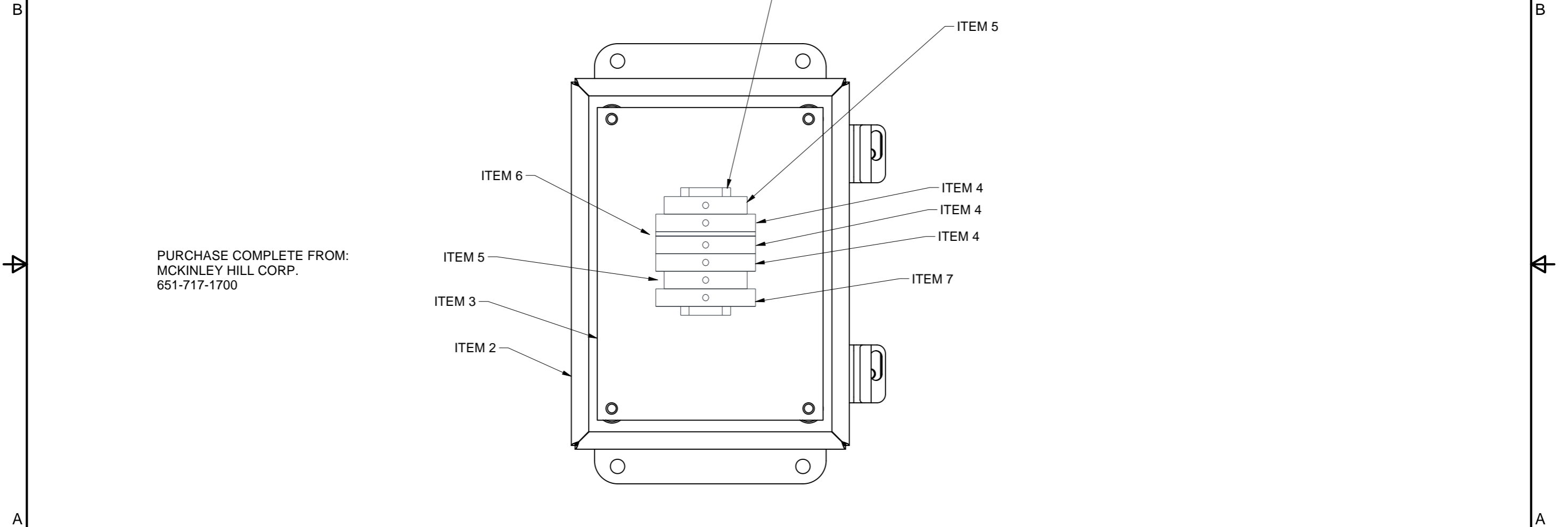

PURCHASE COMPLETE FROM:
MCKINLEY HILL CORP.
651-717-1700



JOB NO:		DRAWN: C Lameyer	TOLERANCES		THIS MATERIAL IS THE PROPERTY OF BGK FINISHING SYSTEMS IT MUST NOT BE COPIED OR IT'S CONTENTS DISCLOSED WITHOUT AUTHORIZATION © 2012 BGK FINISHING SYSTEMS			
QTY AS SHOWN (-1):	QTY OPPOSITE (-2):	DRAWN DATE: 9/4/2012	2 PLACE: .03	FRACT: 1/32				
PROJ MGR: CTL	REL DATE:	MATERIAL:	3 PLACE: .015	ANGULAR:	JUNCTION BOX,STD,8X6X6,AC6			
NEXT ASSY:	FINISH: DEBURR SHARP EDGES	SCALE:	SIZE: B	DRAWING NO: AC-200188				

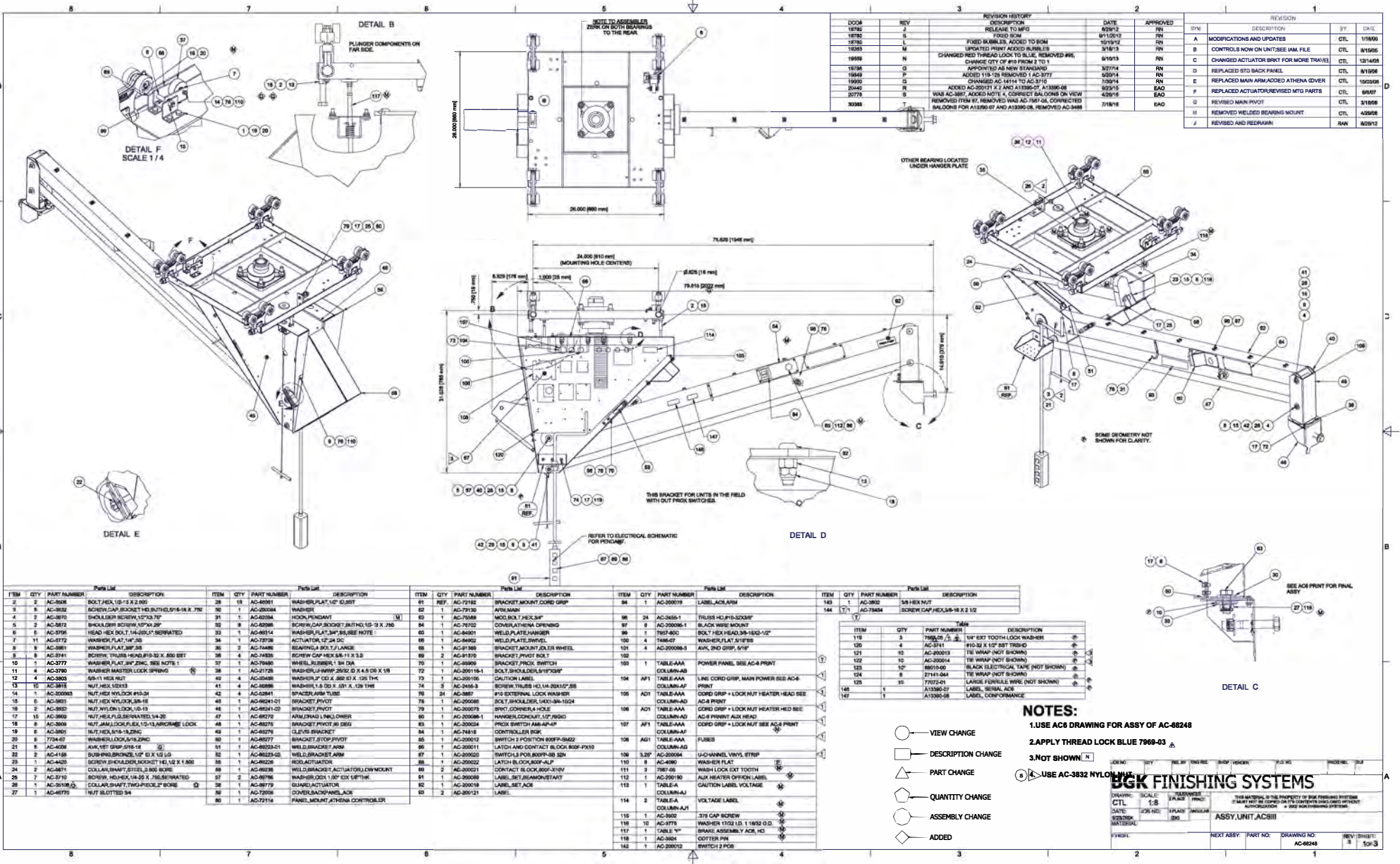

DOOR	REV	DESCRIPTION	DATE	APPROVED	BY	DESCRIPTION	BY	DATE
19780	J	RELEASE TO MFG	05/01/12	RN	RYN	ISSUE FOR TOWN	CTL	1/18/00
19780	K	FIXED BOM	01/10/12	RN	A	MODIFICATIONS AND UPDATES	CTL	1/18/00
19780	L	FIXED BOM	10/19/12	RN	B	CONTROLS NEW ON UNIT/SEE IAM FILE	CTL	01/09/00
13081	M	UPDATED PRINT ADDRESS NUMBERS	3/18/13	RN	C	CHANGED ACTUATOR BRKT FOR MORE TRAVEL	CTL	12/14/00
19988	N	CHANGED RED THREAD LOCK TO BLUE, REMOVED PRL	01/09/13	RN	D	REPLACED STD BACK PANEL	CTL	01/09/00
19780	O	CHANGED CITY OF #10 FROM 3 TO 1	02/07/14	RN	E	REPLACED MAN ARM/ADDED ATHENA COVER	CTL	10/03/00
19948	P	ADDED 119-120 REMOVED 1 AC-3777	05/01/14	RN	F	REPLACED ACTUATOR/REMOVED MFG PARTS	CTL	06/07/00
19990	Q	CHANGED AC 4114 TO AC-3710	7/09/14	EAQ	G	REVISED MAN PIVOT	CTL	3/10/00
20442	R	ADDED AC-20011 X 2 AND A1330-07, A1330-08	09/15/15	EAQ	H	REMOVED WELDED BEARING MOUNT	CTL	02/08/00
20778	S	WAS AC-3887, ADDED NOTE 4, CORRECT BALCOON ON VIEW	02/09/16	EAQ	J	REVISED AED REFRAMIN	RAN	02/01/12
30388	T	REMOVED ITEM 87, REMOVED WAS AC-701 AL, CORRECTED BALCOON FOR A1330-07 AND A1330-08, REMOVED AC-3488	7/16/16	SAC				

ITEM	QTY	PART NUMBER	PART LIST DESCRIPTION	ITEM	QTY	PART NUMBER	PART LIST DESCRIPTION	ITEM	QTY	PART NUMBER	PART LIST DESCRIPTION	ITEM	QTY	PART NUMBER	PART LIST DESCRIPTION
2	2	AC-3688	BOLT, HEX, 1/8" X 1.500	61	REF	AC-7282	BRACKET MOUNT COORD GRIP	98	1	AC-30078	LABEL, AC, ALARM	143	1	AC-382	3/8" HEX NUT
3	8	AC-3832	SCREW, CAP, BUCKNET HD, BUTYL, 1/8" X 1.500	62	1	AC-7970	ARM, MAN	99	24	AC-24661	TRUSS HD, #10-2000R*	144	1	AC-7844	SCREW, CAP, HEX, 3/8" X 1.500
4	2	AC-3870	SHOULDER SCREW, 1/2" X 3/8"	63	1	AC-7068	MOO, BOLT, 1/2" X 3/8"	100	1	AC-30081	TRUSS HD, #10-2000R*				
5	2	AC-3872	SHOULDER SCREW, 1/2" X 3/8"	64	1	AC-7512	COVER, LATHENA DRIVING	101	2	AC-20006-1	BLACK WIRE MOUNT				
6	8	AC-3706	HEAD, HEX, 1/4" X 1/8", SERATED	65	1	AC-8401	WELD, PLATE, HANGER	102	1	7907-800	BOLT, HEX, HEAD, 3/8" X 1/2"				
7	11	AC-8772	WASHER, FLAT, 1/4" X 3/8"	66	1	AC-8402	WELD, PLATE, SWIVEL	103	4	7486-07	WASHER, FLAT, 3/16"				
8	8	AC-3881	WASHER, FLAT, 1/4" X 3/8"	68	1	AC-9130	SPACER, MOUNT, ZER, RING	104	4	AC-20008-3	AVC, 2ND GRIP, 3/16"				
9	8	AC-8741	SCREW, TRUSS, HEAD, #10-20 X 1.500 BBT	69	2	AC-9130	BRACKET, PIVOT, BOLT	105	1	TABLE-AAA	POWER PANEL, SEE AC-8 PRNT				
10	1	AC-3777	WASHER, FLAT, 1/4" X 3/8", SEE NOTE 1	70	1	AC-8989	BRACKET, PROX, SWITCH	106	AD1	TABLE-AAA	LINE CORD GRIP, MAIN POWER, SEE AC-8 PRNT				
11	4	AC-3780	WASHER, FLAT, 1/4" X 3/8"	72	1	AC-20118-1	BOLT, SHOULDER, 1/2" X 3/8"	107	AD1	TABLE-AAA	CORD GRIP + LOCK NUT, HEATER, HEAD, SEE AC-8 PRNT				
12	4	AC-3803	5/8"-11 HEX NUT	73	1	AC-30010	CAUTION LABEL	108	AD1	TABLE-AAA	CORD GRIP + LOCK NUT, HEATER, HEAD, SEE AC-8 PRNT				
13	10	AC-3818	NUT, HEX, 1/2" X 3/8"	74	3	AC-2466-3	SCREW, TRUSS, HD, 1/4" X 1/2" X 3/8"	109	AD1	TABLE-AAA	CORD GRIP + LOCK NUT, HEATER, HEAD, SEE AC-8 PRNT				
14	1	AC-20003	NUT, HEX, NYLON, #10-20 X 1.500	76	24	AC-3887	#10 EXTERNAL LOCK WASHER	110	AD1	TABLE-AAA	FUSES				
15	6	AC-3801	NUT, HEX, NYLON, 3/8" X 1/2"	78	1	AC-20008	BOLT, SHOULDER, 1/2" X 3/8"	111	3	7907-800	WASHER, FLAT				
16	2	AC-3832	NUT, NYLON, LOCK, 1/2" X 3/8"	79	1	AC-20007	BRKT, CONVERTER, HOLE	112	1	AC-20010	AUX, HEX, OFF, ON LABEL				
17	18	AC-3863	NUT, HEX, FL, SERATED, 1/4" X 3/8"	80	1	AC-20006-1	HANGER, CONDUIT, 1/2" FBG	113	1	7707-01	LARGE, SQUARE, WIRE, (NOT SHOWN)				
18	8	AC-3809	NUT, JAM, LOCK, FL, SERATED, 1/4" X 3/8"	81	1	AC-20004	PROX, SWITCH, MAN, ARM	114	1	A1330-07	LABEL, SERIAL, AC				
19	8	AC-3801	NUT, HEX, FL, SERATED, 1/4" X 3/8"	84	1	AC-7418	CONTROLLER, BRK	115	1	A1330-08	LABEL, CONFORMANCE				
20	8	7704-07	WASHER, FLAT, 1/4" X 3/8"	85	1	AC-20012	SWITCH, 2 POSITION, 800V, 30A	116	8	AC-490	WASHER, FLAT				
21	8	AC-4008	ANK, VET, GRIP, #10-20 X 1.500	86	1	AC-20011	LATCH, LANG, CONTACT, BLOCK, 800V, 30A	117	1	TABLE-AAA	CORD GRIP + LOCK NUT, HEATER, HEAD, SEE AC-8 PRNT				
22	2	AC-4188	BUSH, BRONZE, 1/2" O.D. X 1/2" L.G.	87	1	AC-20020	SWITCH, 3 POS, 800V, 30A	118	3/2"	AC-20004	U-CORNER, VINYL, STRIP				
23	1	AC-4431	SCREW, #10-20 X 1.500, BUCKNET HD, 1/2" X 1.500	88	1	AC-20022	LATCH, BLOCK, 800V, 30A	119	8	AC-490	WASHER, FLAT				
24	2	AC-8711	COLLAR, BRNFT, STEEL, SER, BORE	89	2	AC-20021	CONTACT, BLOCK, 800V, 30A	120	1	7907-800	WASHER, FLAT				
25	7	AC-3710	SCREW, HD, HEX, 1/4" X 3/8" X 1.500, SERATED	91	1	AC-20008	LABEL, SET, BEANON, START	121	1	AC-20010	AUX, HEX, OFF, ON LABEL				
26	1	AC-3818	COLLAR, BRNFT, STEEL, SER, BORE	92	1	AC-20019	LABEL, SET, ACK	122	1	TABLE-AAA	CORD GRIP + LOCK NUT, HEATER, HEAD, SEE AC-8 PRNT				
27	1	AC-4070	NUT, BUSH, 1/2" X 3/8"	93	2	AC-30012	LABEL	123	1	TABLE-AAA	CORD GRIP + LOCK NUT, HEATER, HEAD, SEE AC-8 PRNT				
				94	2	AC-30012	LABEL	124	8	AC-490	WASHER, FLAT				
				95	1	AC-20020	SWITCH, 3 POS, 800V, 30A	125	10	AC-20013	THE WRAP (NOT SHOWN)				
				96	1	AC-20022	LATCH, BLOCK, 800V, 30A	126	10	AC-20014	THE WRAP (NOT SHOWN)				
				97	1	AC-20021	CONTACT, BLOCK, 800V, 30A	127	10	8810-00	BLACK ELECTRICAL TAPE (NOT SHOWN)				
				98	1	AC-20008	LABEL, SET, BEANON, START	128	8	2714-044	THE WRAP (NOT SHOWN)				
				99	1	AC-20019	LABEL, SET, ACK	129	10	7707-01	LARGE, SQUARE, WIRE, (NOT SHOWN)				
				100	2	AC-30012	LABEL	147	1	A1330-07	LABEL, SERIAL, AC				
				101	2	AC-30012	LABEL	148	1	A1330-08	LABEL, CONFORMANCE				

- NOTES:**
- USE AC-8 DRAWING FOR ASSY OF AC-8248
 - APPLY THREAD LOCK BLUE 7969-03
 - NOT SHOWN
 - USE AC-3832 NYLON

- VIEW CHANGE
- DESCRIPTION CHANGE
- PART CHANGE
- QUANTITY CHANGE
- ASSEMBLY CHANGE
- ADDED

BGK FINISHING SYSTEMS

THIS MATERIAL IS THE PROPERTY OF BORG PRESIDENTIAL SYSTEMS. IT IS TO BE USED ONLY ON THE EQUIPMENT SPECIFIED. IT IS NOT TO BE REPRODUCED OR COPIED.

SCALE: 1:8

DATE: [] [] []

ISSUE NO: []

ASSY. UNIT: AC818

DRAWING NO: AC-8248

REV: []



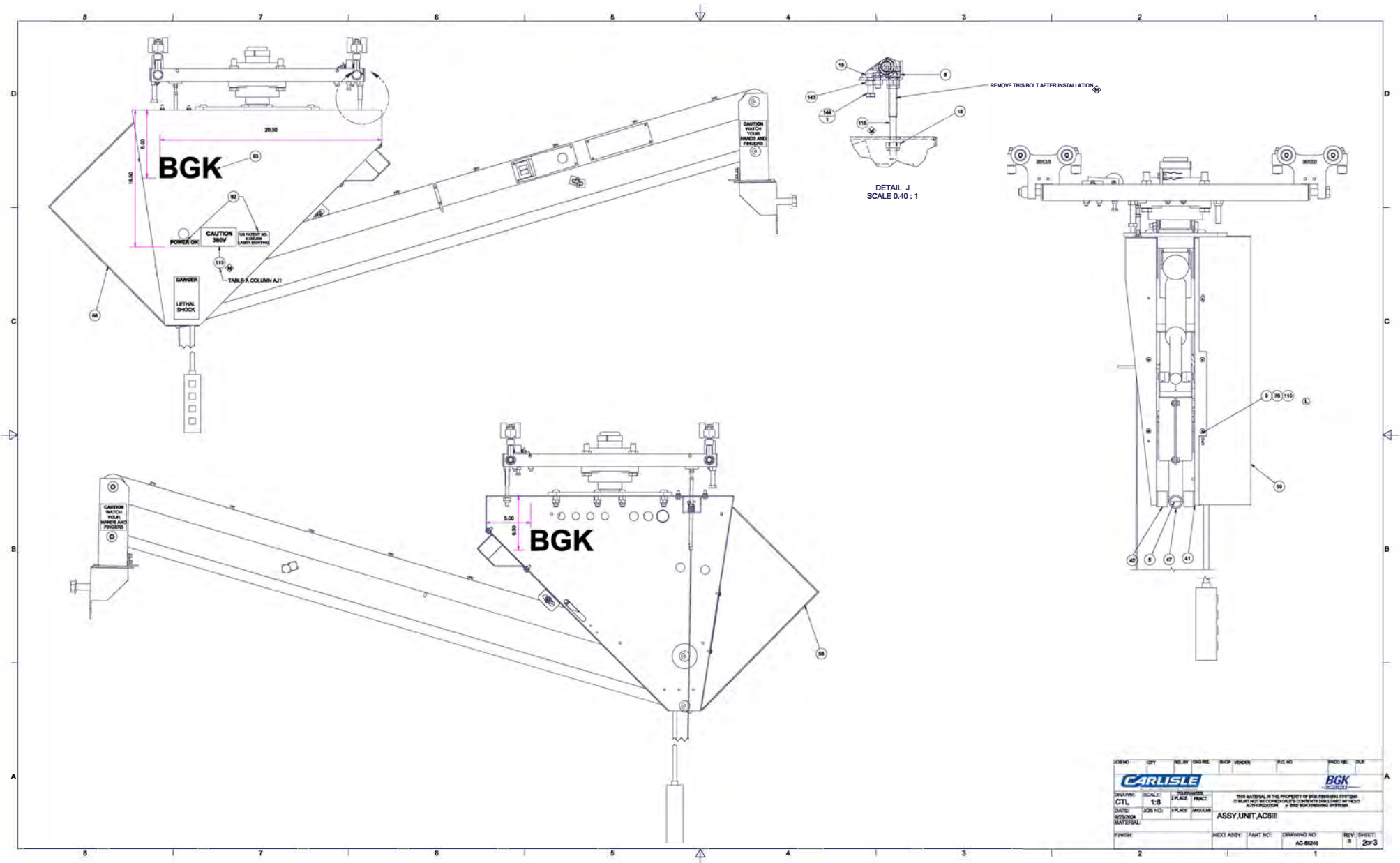

JOB NO.	DIV.	REV. BY	DATE	REV. CHECKED	PLG. NO.	PROJ. NO.	SIZE
CARLISLE		SCALE: 1:8		SHEET: 2 OF 3		BGK	
DRAWN:	DATE:	JOB NO.:	PLANT:	ANGULAR:	THIS MATERIAL IS THE PROPERTY OF BGK. PRESERVE IT CAREFULLY. IT MUST NOT BE COPIED OR THE CONTENTS DISCLOSED WITHOUT AUTHORIZATION. © 2016 BGK. PRESERVE IT CAREFULLY.		
MATERIAL:	ASSY UNIT AC8III						
FINISH:	NEXT ASSY:	PART NO.:	DRAWING NO.:	REV.:	SHEET:		
		AC-80248		3	2		

AVK LOCATIONS (AC6)

NUMBER	AVK-TABLE	
	QTY	PART NUMBER
100	4	7486-07
101	4	200098-3

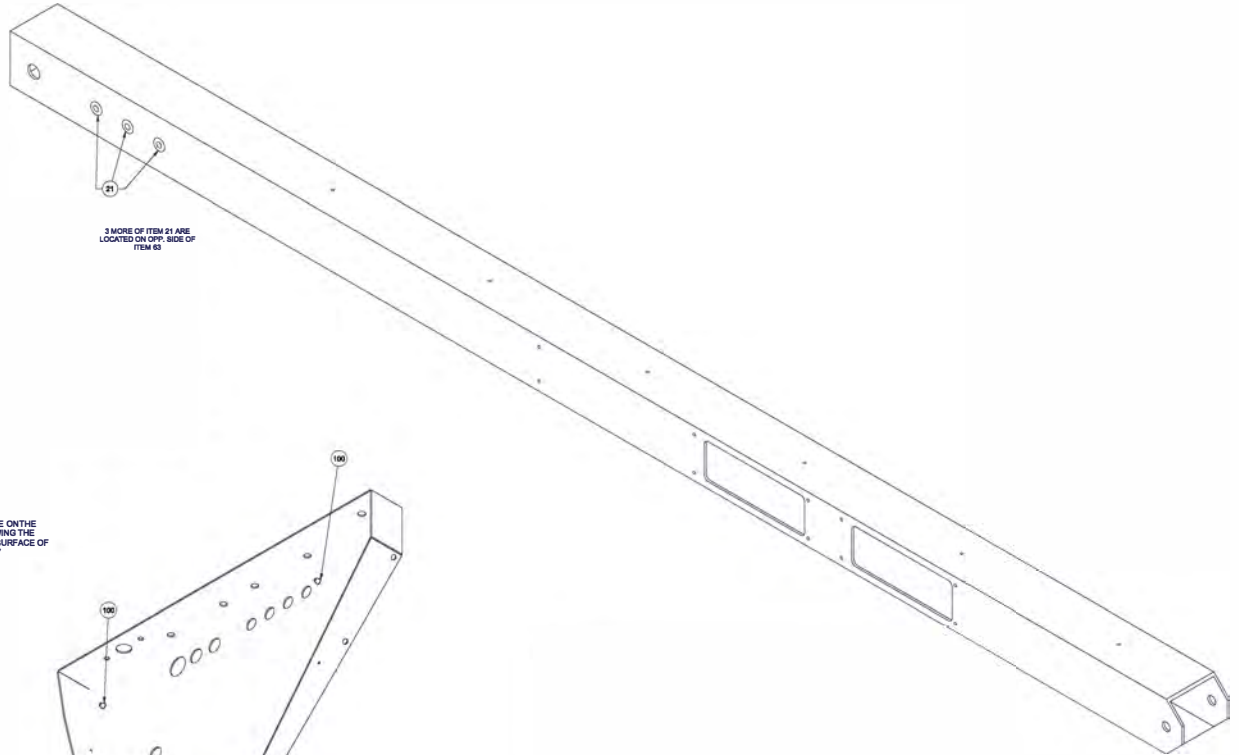

NOTE
 ITEM 101 IS PLACE ON THE INNER SIDE ON THE PANEL WHEN INSTALLING AVK ALLOWING THE ELECTRICAL PANEL TO SIT UP OFF THE SURFACE OF THE INNER PANEL OF ITEM 47

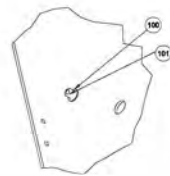
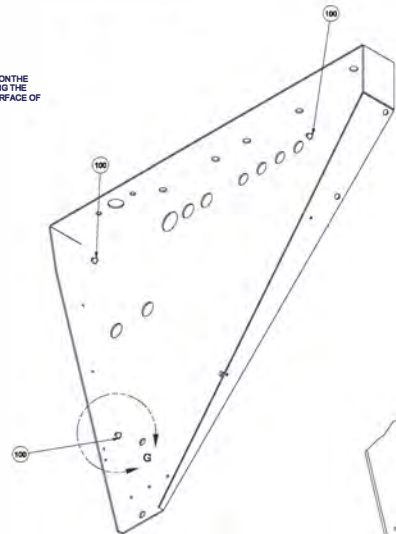
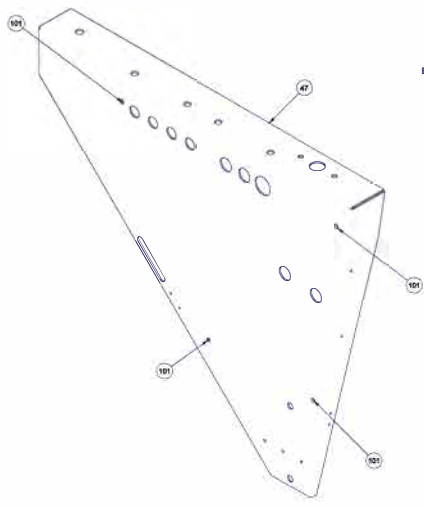

JOB NO.	QTY	REV. BY	ENG. FILE	SHOP	INSPECTOR	P.O. NO.	INSTR. FILE	REV.
CARLISLE						BGK		
DRAWING:	SCALE:	QUANTITY		THIS MATERIAL IS THE PROPERTY OF BGK FLOWING SYSTEMS IT IS TO BE USED ONLY IN THE MANUFACTURE OF THE EQUIPMENT SPECIFIED				
CTL	1:8	PLACE	PRICE	ARM, MAIN				
DATE:	JOB NO.:	PLATE:	ANGLER:					
VERSION:	MATERIAL: SEE P/L							
1. VISIT: WWW.CARLISLE.COM	NEXT ASSY:	PART NO.:	DRAWING NO.:	REV.:	SHEET:			
			AC-8248	R	3			

TABLE "AAA" HEAD CORD & LINE CORD PLUS MTG HARDWARE

REVISION HISTORY				
APP	DATE	DCO	DESC	REV
				SEE SHT.4



VOLTAGE OPTION	ACS - BREAK DOWN DESCRIPTION	TOTAL AMP DRAW	LAMP WIRING DETAIL	USE SUB-ASSY UNIT (AC6)	A1 HEATER HEAD PRINT	AA COMPRESSION SPRING-HEATER HEAD	AA1 BOLT-HEATER HEAD AC-64242-G	AB POWER PANEL W/O J-BOX AC-6	AC HEAD CORD PART No.	AD HEAD CORD + LOCK NUT HEATER HEAD	AD1	AC1 HEAD CORD LENGTH	AE LINE CORD PART No. SEE TABLE "E" FOR LENGTH	AF LINE CORD GRIP	AF1	AG CONTROL PANEL FUSES	AG1	AH2 LOCKNUT	AJ	AJ1
2116-240-PL	2116-240V 1600 Watt Single Head	13.33	Parallel	AC-68248	ACH6-2116	AC-54945	-02	AC-200007	AC-200081-7	AC-200115-3,AC-200117-1	1	15	AC-200081-7	AC-200115-4,AC-200117-2	1	AC-200039	2	3	AC-200191-4	AC-200019 REF
2116-380-SP	2116-380V 1600 Watt Single Head	5.88	Series-Parallel	AC-68248	ACH6-2116	AC-54945	-02	AC-200007	AC-200081-7	AC-200115-3,AC-200117-1	1	15	AC-200081-7	AC-200115-4,AC-200117-2	1	AC-200042	2	3	AC-200191-2	AC-200193-2
2116-480-SP	2116-480V 1600 Watt Single Head	6.67	Series-Parallel	AC-68248	ACH6-2116	AC-54945	-02	AC-200007	AC-200081-7	AC-200115-3,AC-200117-1	1	15	AC-200081-7	AC-200115-4,AC-200117-2	1	AC-200042	2	3	AC-200191-3	AC-200019 REF
2116-575-SP	2116-575V 1600 Watt Single Head	7.35	Series-Parallel	AC-68248	ACH6-2116	AC-54945	-02	AC-200194-1	AC-200081-7	AC-200115-3,AC-200117-1	1	15	AC-200081-7	AC-200115-4,AC-200117-2	1	AC-200042	2	3	AC-200191-1	AC-200193-3
2125-240-PL	2125-240V 2500 Watt Single Head	7.16	Parallel	AC-68248	ACH6-2125	AC-54945	-02	AC-200007	AC-200081-7	AC-200115-3,AC-200117-1	1	15	AC-200081-7	AC-200115-4,AC-200117-2	1	AC-200042	2	3	AC-200191-4	AC-200019 REF
2125-480-PL	2125-480V 2500 Watt Single Head	10.42	Parallel	AC-68248	ACH6-2125	AC-54945	-02	AC-200007	AC-200081-7	AC-200115-3,AC-200117-1	1	15	AC-200081-7	AC-200115-4,AC-200117-2	1	AC-200039	2	3	AC-200191-3	AC-200019 REF
4125-240-PL	4125-240V 2500 Watt Single Head	14.33	Parallel	AC-68248	ACH6-4125	AC-200125-3	-01	AC-200007	AC-200081-7	AC-200115-3,AC-200117-1	1	15	AC-200081-7	AC-200115-4,AC-200117-2	1	AC-200037	2	3	AC-200191-4	AC-200019 REF
4125-480-PL	4125-480V 2500 Watt Single Head	20.83	Parallel	AC-68248	ACH6-4125	AC-200125-3	-01	AC-200007	AC-200081-5	AC-200115-3,AC-200117-1	1	15	AC-200081-5	AC-200115-4,AC-200117-2	1	AC-200038	2	3	AC-200191-3	AC-200019 REF
4138-240-PL	4138-240V 3800 Watt Single Head	16.72	Parallel	AC-68248	ACH6-4138	AC-200125-3	-01	AC-200007	AC-200081-7	AC-200115-3,AC-200117-1	1	15	AC-200081-7	AC-200115-4,AC-200117-2	1	AC-200037	2	3	AC-200191-4	AC-200019 REF
4138-380-PL	4138-380V 3800 Watt Single Head	21.42	Parallel	AC-68248	ACH6-4138	AC-200125-3	-01	AC-200007	AC-200081-5	AC-200115-3,AC-200117-1	1	15	AC-200081-5	AC-200115-4,AC-200117-2	1	AC-200038	2	3	AC-200191-2	AC-200019 REF
4138-480-PL	4138-480V 3800 Watt Single Head	24.3	Parallel	AC-68248	ACH6-4138	AC-200125-3	-01	AC-200007	AC-200081-4	AC-200115-8,AC-200117-1	1	15	AC-200081-4	AC-200115-2,AC-200117-2	1	AC-200040	2	3	AC-200191-3	AC-200019 REF
2216-240-PL	2216-240V 1600 Watt Dual Head	26.67	Parallel	AC-68248	ACH6-2216	AC-54945	-02	AC-200006	AC-200081-7	AC-200115-3,AC-200117-1	2	15 (X2)	AC-200081-4	AC-200115-4,AC-200117-2	2	AC-200037	4	6	AC-200191-4	AC-200019 REF
2216-380-SP	2216-380V 1600 Watt Dual Head	17.09	Series-Parallel	AC-68248	ACH6-2216	AC-54945	-02	AC-200006	AC-200081-7	AC-200115-3,AC-200117-1	2	15 (X2)	AC-200081-7	AC-200115-4,AC-200117-2	2	AC-200042	4	6	AC-200191-2	AC-200019 REF
2216-480-SP	2216-480V 1600 Watt Dual Head	13.33	Series-Parallel	AC-68248	ACH6-2216	AC-54945	-02	AC-200006	AC-200081-7	AC-200115-3,AC-200117-1	2	15 (X2)	AC-200081-7	AC-200115-4,AC-200117-2	2	AC-200042	4	6	AC-200191-3	AC-200019 REF
2216-575-SP	2216-575V 1600 Watt Dual Head	14.7	Series-Parallel	AC-68248	ACH6-2216	AC-54945	-02	AC-200194-2	AC-200081-7	AC-200115-3,AC-200117-1	2	15 (X2)	AC-200081-7	AC-200115-4,AC-200117-2	2	AC-200042	4	6	AC-200191-1	AC-200193-3
2225-240-SP	2225-240V 2500 Watt Dual Head	14.33	Series-Parallel	AC-68248	ACH6-2225	AC-54945	-02	AC-200006	AC-200081-5	AC-200115-3,AC-200117-1	2	15 (X2)	AC-200081-7	AC-200115-4,AC-200117-2	2	AC-200042	4	6	AC-200191-4	AC-200019 REF
2225-380-SP	2225-380V 2500 Watt Dual Head	18.36	Series-Parallel	AC-68248	ACH6-2225	AC-54945	-02	AC-200006	AC-200081-5	AC-200115-3,AC-200117-1	2	15 (X2)	AC-200081-7	AC-200115-4,AC-200117-2	2	AC-200039	4	6	AC-200191-2	AC-200019 REF
2225-480-PL	2225-480V 2500 Watt Dual Head	20.83	Parallel	AC-68248	ACH6-2225	AC-54945	-02	AC-200006	AC-200081-7	AC-200115-3,AC-200117-1	2	15 (X2)	AC-200081-5	AC-200115-4,AC-200117-2	2	AC-200039	4	6	AC-200191-3	AC-200019 REF
2225-575-SP	2225-575V 2500 Watt Dual Head	7.90	Series-Parallel	AC-68248	ACH6-2225	AC-54945	-02	AC-200194-2	AC-200081-7	AC-200115-8,AC-200117-1	2	15 (X2)	AC-200081-7	AC-200115-4,AC-200117-2	2	AC-200041	4	6	AC-200191-1	AC-200193-3
4225-240-PL	4225-240V 2500 Watt Dual Head	28.66	Parallel	AC-68248	ACH6-4225	AC-200125-3	-01	AC-200006	AC-200081-5	AC-200115-3,AC-200117-1	2	15 (X2)	AC-200081-4	AC-200115-4,AC-200117-2	2	AC-200037	4	6	AC-200191-4	AC-200019 REF
4225-380-PL	4225-380V 2500 Watt Dual Head	36.73	Parallel	AC-68248	ACH6-4225	AC-200125-3	-01	AC-200006	AC-200081-5	AC-200115-3,AC-200117-1	2	15 (X2)	AC-200081-3	AC-200114-4,AC-200117-3	2	AC-200037	4	6	AC-200191-2	AC-200193-2
4225-480-PL	4225-480V 2500 Watt Dual Head	41.67	Parallel	AC-68248	ACH6-4225	AC-200125-3	-01	AC-200006	AC-200081-5	AC-200115-3,AC-200117-1	2	15 (X2)	AC-200081-2	AC-200114-4,AC-200117-3	2	AC-200038	4	6	AC-200191-3	AC-200019 REF
4225-480-SP	4225-480V 2500 Watt Dual Head	20.83	Series-Parallel	AC-68248	ACH6-4225	AC-200125-3	-01	AC-200006	AC-200081-7	AC-200115-3,AC-200117-1	2	15 (X2)	AC-200081-7	AC-200115-4,AC-200117-2	2	AC-200039	4	6	AC-200191-3	AC-200019 REF
4225-575-PL	4225-575V 2500 Watt Dual Head	45.93	Parallel	AC-68248	ACH6-4225	AC-200125-3	-01	AC-200194-2	AC-200081-5	AC-200115-3,AC-200117-1	2	15 (X2)	AC-200081-2	AC-200114-4,AC-200117-3	2	AC-200038	4	6	AC-200191-1	AC-200193-3
4225-575-SP	4225-575V 2500 Watt Dual Head	22.97	Series-Parallel	AC-68248	ACH6-4225	AC-200125-3	-01	AC-200194-2	AC-200081-7	AC-200115-8,AC-200117-1	2	15 (X2)	AC-200081-7	AC-200115-4,AC-200117-2	2	AC-200039	4	6	AC-200191-1	AC-200191-3

CONTINUED ON SHEET 2

NOTES:

- *LINE CORD LENGTH MAY INCREASE DEPENDENT UPON GANTRY RUN (DEVIATION REQUIRED).
- BECAUSE OF THE QTY'S OF MATERIALS THICKNESS, THE VARIANCE OF TOLERANCES MAY REQUIRE A COMBINATION OF ITEMS 4 AND 5.
- CONNECT CABLE TO PYROMETER FOLLOW COLOR CODING ON PYROMETER ASSY.

- SP - REQUIRES WRITTEN DEVIATION BY ENGINEERING DOCUMENTARY SPECIAL SETTINGS AND OR CABLE LENGTHS
- SOME UNITS REQUIRE ONE LINE CORD SEE TABLE "A" TO DETERMINE IF TWO ARE REQUIRED (X2XX-XXX-XX VOLTAGE OPTIONS REQUIRE TWO CORDS)
- QTY VARIES

- MAX POWER SETTING 75%
- ATTACH CAUTION TAG, AC-200105 TO LINE CORD USING AC-200013 TIE. ENSURE A CORRECT VOLTAGE LABEL IS PLACED ONTO TAG
- MAX POWER SETTING 60%

DRAWING: CTL	SCALE:	TOLERANCES: FRACTIONAL & DECIMAL	DATE:	JOB NO:	SHEET:	REV:	DATE:	BY:	CHECKED:	APPROVED:	PROJ. NO.:	PROD. REL.:	DATE:
<p>THIS MATERIAL IS THE PROPERTY OF BGR TRAINING SYSTEMS. IT MUST NOT BE COPIED OR ITS CONTENTS DISCLOSED WITHOUT AUTHORIZATION. © 2008 BGR TRAINING SYSTEMS</p> <p>AC-6 MASTER ASSY AUTO CURE 6000</p> <p>NEXT ASSY: AC6</p>													
<p>FINISH:</p>											REV: SHEET:	N 1 OF 4	

REVISION HISTORY				
APP	DATE	DCO	DESC	REV
				SEE SHT.4

TABLE "AAA" HEAD CORD & LINE CORD PLUS MTG HARDWARE - CONTINUED

VOLTAGE	AC6- BREAK DOWN	TOTAL AMP	LAMP WIRING	USE SUB-	A1	AA	AA1	AB	AC	AD	AD AC1	AE	AF	AF AG	A	AH2	AJ	AJ1		
OPTION	DESCRIPTION	DRAW	DETAIL	SUB ASSEMBLY UNIT (AC6)	HEATER HEAD PRINT	COMPRESSION SPRING - HEATER HEAD	BOLT, HEATER HEAD AC-64242-	POWER PANEL W/O J BOX AC6	HEAD CORD PART NO.	HEAD CORD + LOCK NUT HEATER HEAD	QTY	HEATER HEAD CORD LENGTH	LINE CORD PART NO. SEE TABLE "E" FOR LENGTH	LINE CORD GRIP	QTY	CONTROL PANEL FUSES	QTY	LOCK NUT		
4238-240-PL	4238-240V 3800 WATT Dual Head	33.43	PARALLEL	AC-68248	ACH6-4238	AC-200125-3	-01	AC-200194-2	AC-200081-7	AC-200115-3, AC-200117-1	2	15 (X2)	AC-200081-3	AC-200114-3, AC-200117-3	2	AC-200037	4	6	AC-200191-4	AC-200019 REF
4238-240-SP	4238-240V 3800 WATT Dual Head	11.5	SERIES-PARALLEL	AC-68248	ACH6-4238	AC-200125-3	-01	AC-200194-2	AC-200081-7	AC-200115-3, AC-200117-1	2	15 (X2)	AC-200081-7	AC-200115-4, AC-200117-2	2	AC-200042	4	6	AC-200191-4	AC-200019 REF
4238-380-PL	4238-380V 3800 Watt Dual Head	42.85	PARALLEL	AC-68248	ACH6-4238	AC-200125-3	-01	AC-200006	AC-200081-5	AC-200115-8, AC-200117-1	2	15 (X2)	AC-200081-2	AC-200114-2, AC-200117-3	2	AC-200038	4	6	AC-200191-2	AC-200019 REF
4238-480-PL	4238-480V 3800 Watt Dual Head	48.61	PARALLEL	AC-68248	ACH6-4238	AC-200125-3	-01	AC-200006	AC-200081-4	AC-200115-8, AC-200117-1	2	15 (X2)	AC-200081-2	AC-200114-2, AC-200117-3	2	AC-200040	4	6	AC-200191-3	AC-200019 REF
4238-480-SP	4238-480V 3800 Watt Dual Head	16.72	SERIES-PARALLEL	AC-68248	ACH6-4238	AC-200125-3	-01	AC-200006	AC-200081-7	AC-200115-3, AC-200117-1	2	15 (X2)	AC-200081-7	AC-200115-4, AC-200117-2	2	AC-200042	4	6	AC-200191-3	AC-200019 REF
4238-575-SP	4238-575V 3800 Watt Dual head	18.43	SERIES-PARALLEL	AC-68248	ACH6-4238	AC-200125-3	-01	AC-200194-2	AC-200081-7	AC-200115-3, AC-200117-1	2	15 (X2)	AC-200081-5	AC-200115-4, AC-200117-2	2	AC-200039	4	6	AC-200191-1	AC-200019 REF

NOTES:

- 1 > LINE CORD LENGTH MAY INCREASE DEPENDENT UPON GANTRY RUN (DEVIATION REQUIRED).
- 2 > BECAUSE OF THE QUANTITIES OF MATERIALS THICKNESS, THE VARIANCE OF TOLERANCE MAY REQUIRE A COMBINATION OF ITEMS 4 AND 5
- 3 > CONNECT CABLE TO PYROMETER, FOLLOW COLOR CODING ON PYROMETER ASSY.
- 4 > SP- REQUIRES WRITTEN DEVIATION BY ENGINEERING DOCUMENTARY SPECIAL SETTINGS AND/ OR CABLE LENGTHS
- 5 > SOME UNITS REQUIRE ONE LINE CORD -SEE TABLE "A" TO DETERMINE IF TWO ARE REQUIRED (X2XXX-XXX-XX VOLTAGE OPTIONS REQUIRE TWO CORDS)
- 6 > QTY VARIES
- 7 > MAX POWER SETTING 75%
- 8 > ATTACH CAUTION TAG, AC-200105 TO LINE CORD USING AC-200013 TIE. ENSURE A CORRECT VOLTAGE LABEL IS PLACED ONTO TAG
- 9 > MAX POWER SETTING 60%

JOB NO:	QTY:	REL BY:	ENG REL:	SHOP:	VENDER:	P.O. NO:	PROD REL:	DATE:
CARLISLE		SCALE:		TOLERANCES:		THIS MATERIAL IS THE PROPERTY OF BOK TRAINING SYSTEMS. IT MUST NOT BE COPIED OR ITS CONTENTS DISCLOSED WITHOUT AUTHORIZATION. + SPEC BOK TRAINING SYSTEMS		
DRAWN:	CTL	SCALE:	2" FRAC	1" FRAC	1/2" FRAC			
DATE:	JOB NO:	SYMBOL:	1/8" DIA	1/4" DIA	3/8" DIA	AC-6 MASTER ASSY		
MATERIAL:	FINISH:	NEXT ASSY:	PART NO:	REV:	SHEET:	N 2 OF 4		

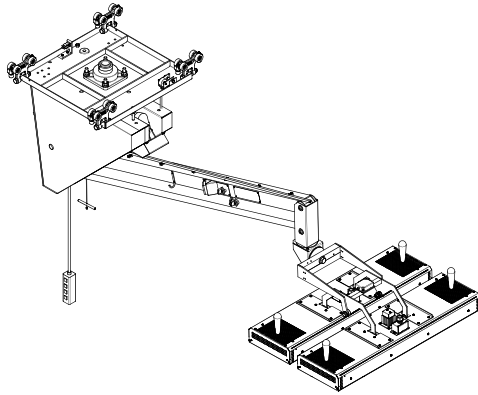

TABLE "B" JUNCTION BOX OPTION

OPTION	QTY. PER ASSY	PART NO.	DESCRIPTION
N			JUNCTION BOX ASSEMBLY-AC6
J	1	AC-200188	JUNCTION BOX ASSEMBLY-AC6

TABLE "C" CONTROLLER SELECTION

OPTION	DESCRIPTION
F	FARIENHIET (DEGREES F)
C	CELCIUS (DEGREES C)

TABLE "D" POWER SETTING (ATHENA CONTROLLER)

OPTION	DESCRIPTION
SP	SPECIAL POWER SETTING - DEVIATION REQUIRED
40	40% POWER SETTING OF THE ATHENA CONTROLLER
45	45% POWER SETTING OF THE ATHENA CONTROLLER
50	50% POWER SETTING OF THE ATHENA CONTROLLER
60	60% POWER SETTING OF THE ATHENA CONTROLLER
75	75% POWER SETTING OF THE ATHENA CONTROLLER
100	100% POWER SETTING OF THE ATHENA CONTROLLER

TABLE "E" LINE CORD LENGTH

OPTION	FEET/METERS	PART #
30	30/9.144	TABLE AAA - COLUMN AE (8)
50	50/15.244	TABLE AAA - COLUMN AE (8)
G 75	75/22.86	TABLE AAA - COLUMN AE (8)
100	100/30.48	TABLE AAA - COLUMN AE (8)
SP		DEVIATION REQUIRED (8)

TABLE "F" - BRAKE FOOT OPTION		
DAS	PART	DESCRIPTI
1	AC-200206-1	UHMW BRAKE FOOT
2	AC-200206-2	RUBBER BRAKE FOOT

EXAMPLE:

AC6-4238-480-SP-J-F-75-10-1

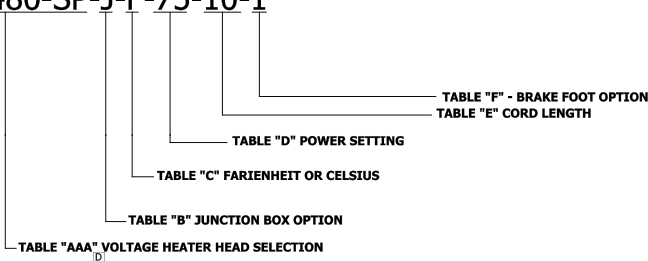

JOB NO.	QTY.	REL BY	ENG REL	SHOP	VENDER	P.O. NO.	PROD REL	DATE
CARLISLE		SCALE: 1/8" = 1"		TOLERANCES: 2 PLACE 1/16" 3 PLACE 1/32"		THIS MATERIAL IS THE PROPERTY OF BOK TRAINING SYSTEMS. IT MUST NOT BE COPIED OR ITS CONTENTS DISCLOSED WITHOUT AUTHORIZATION. * SPEC FOR FINISHING SYSTEMS		
DATE:	JOB NO.:	SYMBOL:	MATERIAL:	AC-6 MASTER ASSY		AUTO CURE 6000		
FINISH:	NEXT ASSY:	PART NO.:	AC6	REV: SHEET:		N 3 OF 4		

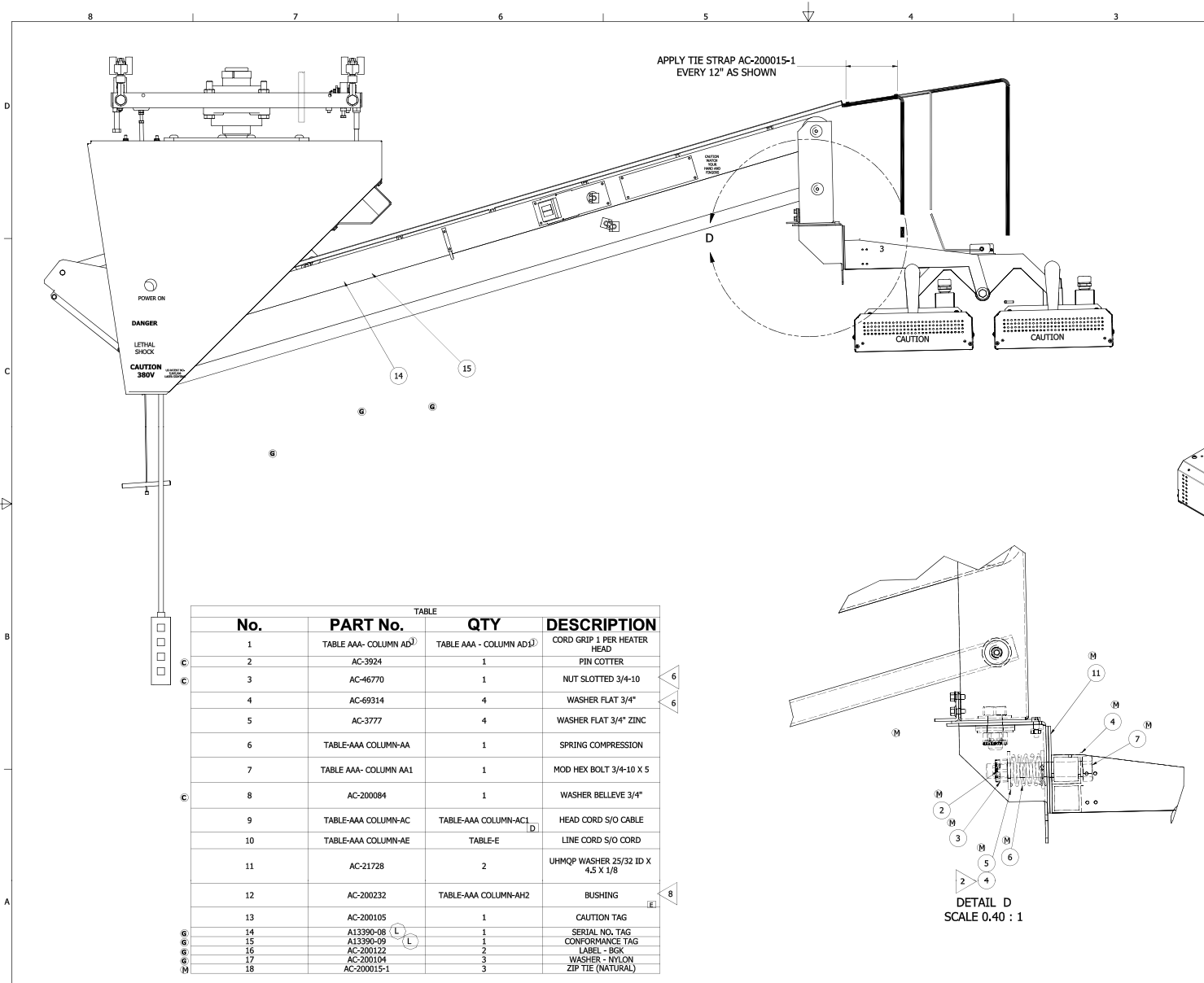

DCO#	REV	DESCRIPTION	DATE	APPROVED
18780	G	RELEASE TO MFG	6/29/2012	RN
18780	B	NEW EXCEL SPREADSHEET	9/11/2012	RN
18780	C	UPDATED TABLE	10/13/13	RN
19252	D	UPDATED TABLE AND SHEETS	3/18/13	RN
19695	E	ADDED BUSHING AC-200232	1/9/14	RN
19798	F	APPOINTED AS NEW STANDARD	3/27/14	RN
20440	G	WAS AC-200039, WAS AC-200081-7, ADD A13390-07, A13390-08, AC-100122 X 2 ADD TABLES J AND K, EXPAND PART NUMBER TABULATION TO INCLUDE BRAKE OPTIONS, ADD 2225-380, ADD COLUMN AA1 FOR HEATER HEAD MOUNTING BOLT OPTIONS ADD NYLON WASHER REPLACEMENT SKETCH	1/8/16	EAO
20710	H	REVERSE -01 AND -02	3/7/16	EAO
20818	J	WAS AC-200081-5, WAS AC-200115-3, WAS AC-200117-1, REMOVED COLUMN AH1, CHANGE HEADING, CORRECT ITEM 1, ADD SHEET 2, ADD 4136-380-PL, ADD CONTINUED TABLE AAA TO SHEET 2, RENUMBERED SHEETS	5/19/16	EAO
30621	K	ADDED 2216-380-PL, REVISED QTY FOR 2216-240-PL IN AD1, AC1, AF1, AG1, AND AH2 TO REFLECT 2 HEADS	1/10/17	EAO
30995	L	WAS A13390-07, WAS A13390-08, CORRECT HEAD CABLE ON 4125-240, 4125-240, 2216-240, 4225-575, 4238-240 SP&PL, 4238-480 SP&PL, 4238-575	2/16/17	EAO
31723	M	ADDED BALLOONS TO DETAIL C PG 4, ADD ZIP TIE TO BOM	08/30/17	EAO
32503	N	FIX 2216-380-SP, WAS -PL, UPDATE AMP READINGS, FUSE SELECTION, AND LABEL P/N'S	3/29/18	BCS

No.	PART No.	QTY	DESCRIPTION
1	TABLE AAA- COLUMN AD ¹	TABLE AAA - COLUMN AD ¹	CORD GRIP 1 PER HEATER HEAD
2	AC-3924	1	PIN COTTER
3	AC-46770	1	NUT SLOTTED 3/4-10
4	AC-69314	4	WASHER FLAT 3/4"
5	AC-3777	4	WASHER FLAT 3/4" ZINC
6	TABLE-AAA COLUMN-AA	1	SPRING COMPRESSION
7	TABLE-AAA- COLUMN AA1	1	MOD HEX BOLT 3/4-10 X 5
8	AC-200084	1	WASHER BELLEVE 3/4"
9	TABLE-AAA COLUMN-AC	TABLE-AAA COLUMN-AC ¹	HEAD CORD S/O CABLE
10	TABLE-AAA COLUMN-AE	TABLE-E	LINE CORD S/O CORD
11	AC-21728	2	UHMQP WASHER 25/32 ID X 4.5 X 1/8
12	AC-200232	TABLE-AAA COLUMN-AH2	BUSHING
13	AC-200105	1	CAUTION TAG
14	A13390-08	1	SERIAL NO. TAG
15	A13390-09	1	CONFORMANCE TAG
16	AC-200132	2	LABEL - B&K
17	AC-200104	3	WASHER - NYLON
18	AC-200015-1	3	ZIP TIE (NATURAL)

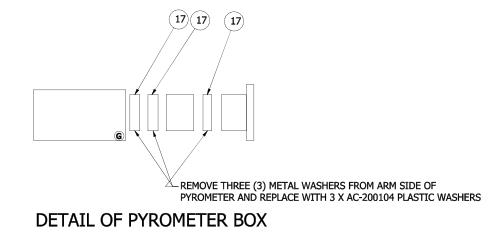
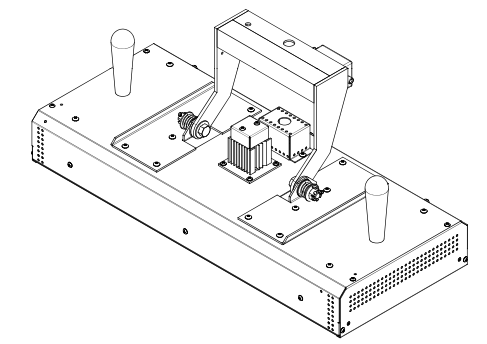
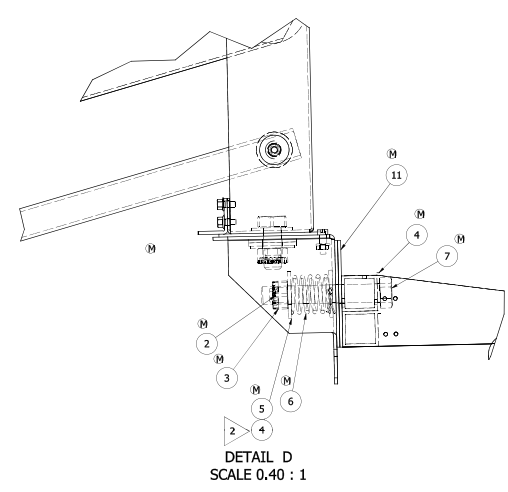

JOB NO:	QTY:	REL BY:	ENG REL:	SHOP:	VENDER:	P/O NO:	PROD REL:	DATE:
SCALE:	TOLERANCES:	THIS MATERIAL IS THE PROPERTY OF B&K TRAINING SYSTEMS. IT MUST NOT BE COPIED OR ITS CONTENTS DISCLOSED WITHOUT AUTHORIZATION. © B&K TRAINING SYSTEMS						
DATE:	JOB NO:	SCALE:	FRAC:	FRAC:	FRAC:	FRAC:	FRAC:	FRAC:
SIZES:	MATERIAL:	ASBY:	HEATER:	A125AC-8	MASTER ASSY:	AUTO CURE 6000		
FINISH:	NEXT ASSY:	PART NO:	AC5	REV: SHEET: N 4 OF 4				

AUTOCURE MODEL NUMBER

AC6-2216-480-SP

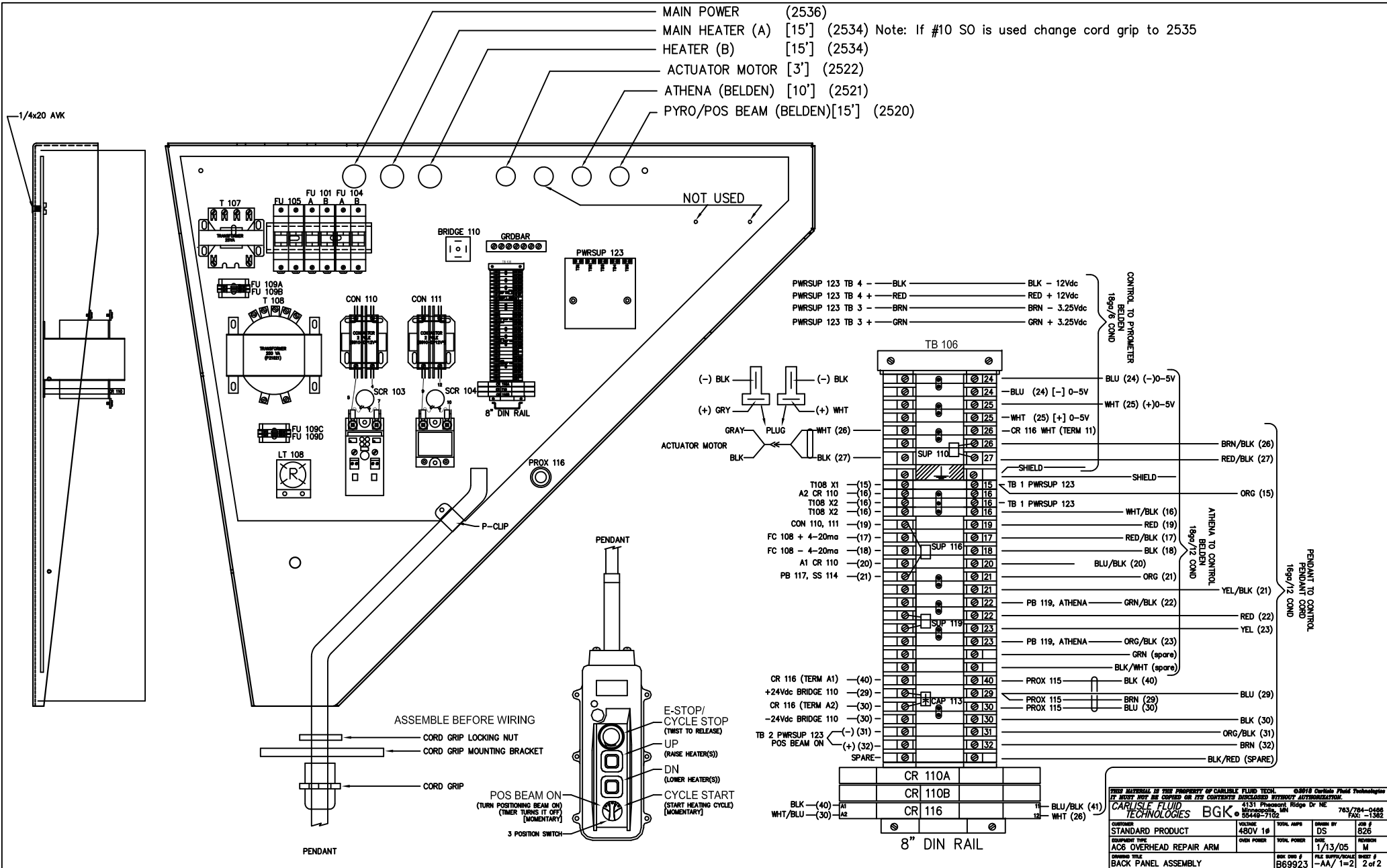

THIS MATERIAL IS THE PROPERTY OF CARLISLE FLUID TECH. ©2010 Carlisle Fluid Technologies. IT MUST NOT BE COPIED OR REPRODUCED WITHOUT AUTHORIZATION.

CARLISLE FLUID TECHNOLOGIES BGK • 4131 Pleasant Ridge Dr NE • 763-784-0448 • 800-448-7102 • FAX: -1382

DESCRIPTION	QUANTITY	UNIT	DATE	REVISION
STANDARD PRODUCT	480V 16	DS	1/13/05	M
EQUIPMENT TYPE	AC6 OVERHEAD REPAIR ARM	OVER POWER		
DRAWING TITLE	BACK PANEL ASSEMBLY	REV DATE	FILE NUMBER	SHEET #
		B69923	-AA/1-2	2 of 2

****THIS DOCUMENT APPLIES IF YOUR SYSTEM IS EQUIPPED WITH A SPRAY/BAKE SWITCH**

Small junction box to interlock controls during spraying.

Maximum Load: 40A FLA, 50A Resistive

Four configurations:

240V 1 ϕ 480V 1 ϕ

240V 3 ϕ 480V 3 ϕ

2 Modes of Operation

Local: There is a 2 position switch on the front of the box to switch from Spray to Bake.

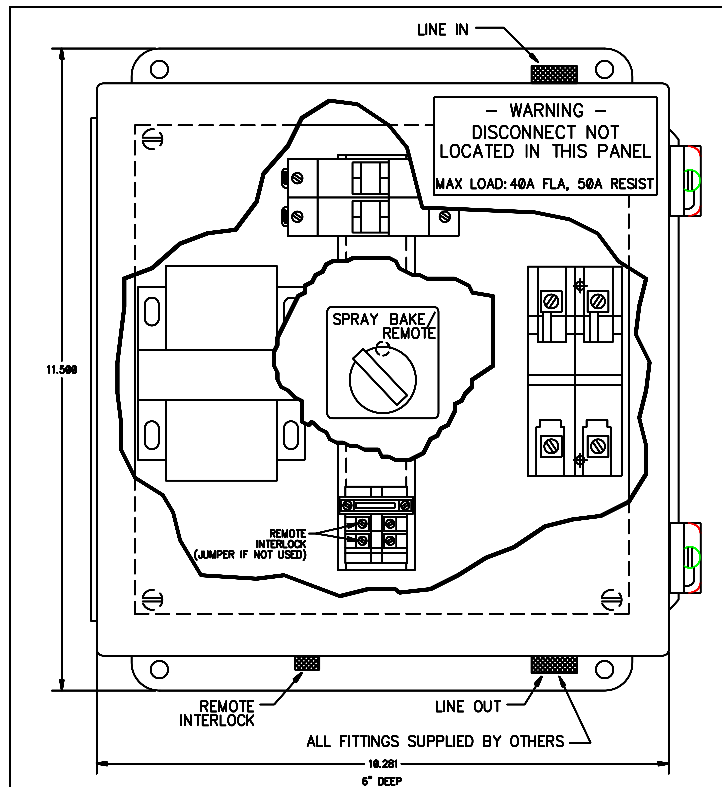

THIS MATERIAL IS THE PROPERTY OF BGK FINISHING SYSTEMS, © 2003 BY BGK FINISHING SYSTEMS. IT MUST NOT BE COPIED OR ITS CONTENTS DISCLOSED WITHOUT AUTHORIZATION.

ITW BGK		BGK Finishing Systems 4131 Pheasant Ridge Dr NE		Minneapolis, MN 55449-7102 763/784-0466 FAX: -1362	
CUSTOMER	VOLTAGE	TOTAL AMPS	DRAWN BY	JOB #	
-	240V 1 ϕ	-	DS	-	
EQUIPMENT TYPE	OVEN POWER	TOTAL POWER	DATE	REVISION	
INTERLOCK J-BOX	-	-	11/7/03	-	
DRAWING TITLE	MAXIMUM LOAD	BGK DWG #	FILE SUFFIX/SCALE	SHEET #	
ENCL ASSY	40A FLA/50A RESISTIVE	A65739	-AA/ 1=2	2 of 2	

REVISION HISTORY				
DCO	REV	DESCRIPTION	DATE	APPROVED
19112	B	UPDATED BOM ADDED ENGINEERING NOTES	1/30/13	RN
19887	C	CHANGED # 28 TO AC-50686-3	7/7/14	RN
20524	D	ADD NOTES TO SHT 4	11/12/2015	EAO

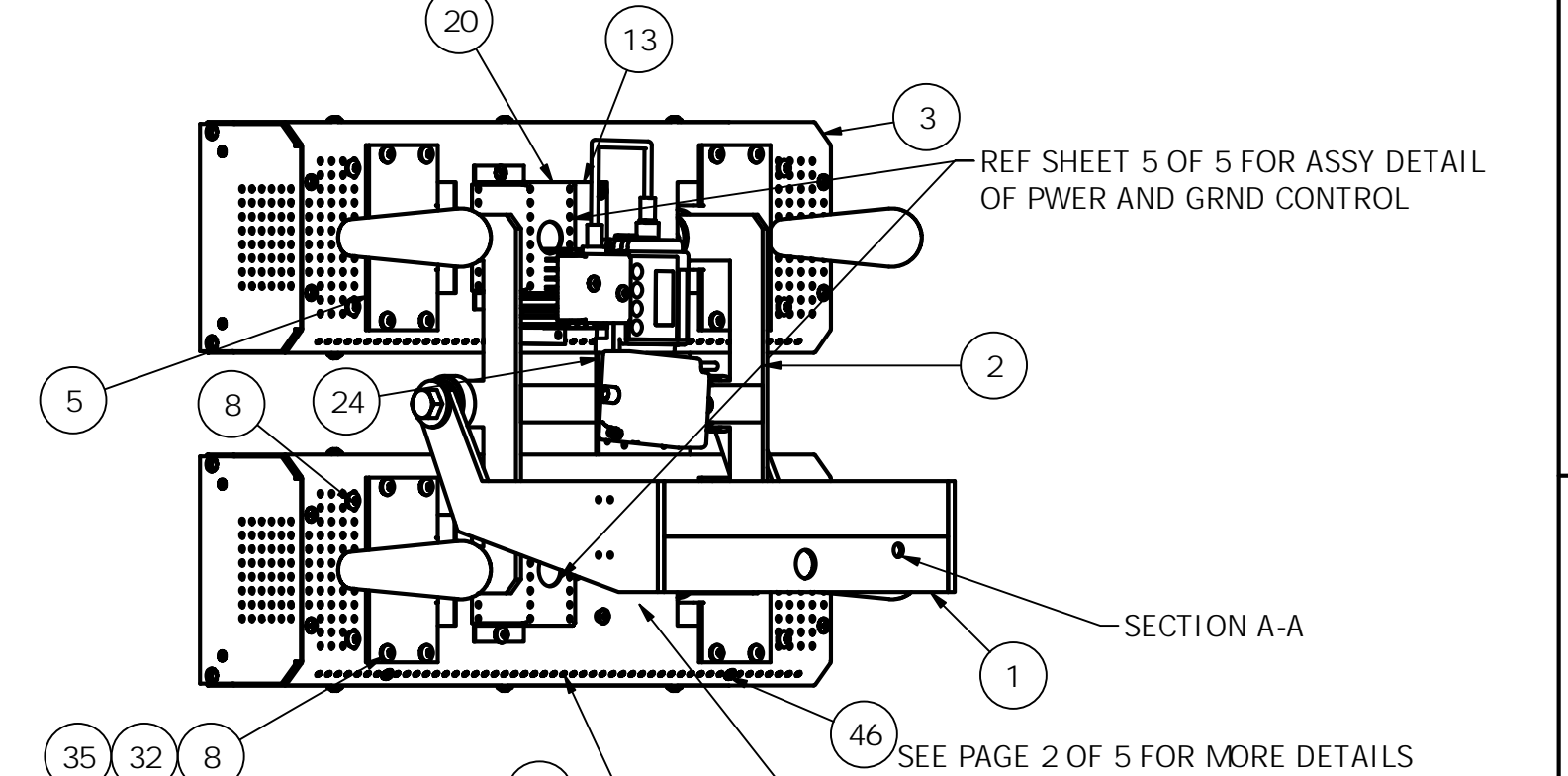
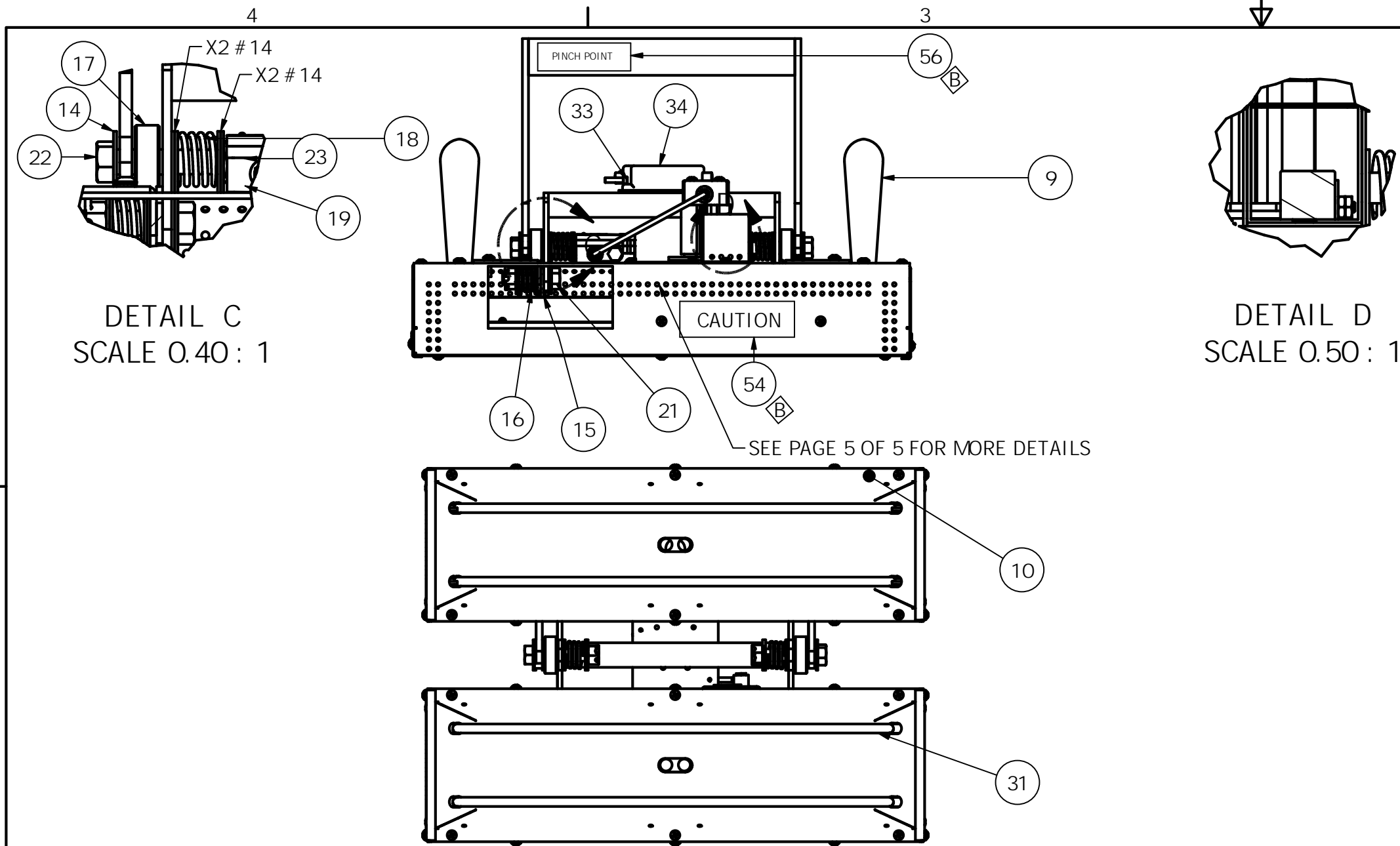

- VIEW CHANGE
- DESCRIPTION CHANGE
- PART CHANGE
- QUANTITY CHANGE
- ASSEMBLY CHANGE
- ADDED

PARTS LIST				PARTS LIST			
ITEM	QTY	PART NUMBER	DESCRIPTION	ITEM	QTY	PART NUMBER	DESCRIPTION
1	1	AC-61940	WELD, PIVOT, MAIN, DUAL, 2 LAMP	25	4	AC-64095	PLATE, REINFORCEMENT, H ANDLE
2	1	AC-61938	WELD, PIVOT, DUAL, 2 LAMP	26	4	AC-4012	3/8-16 AVK, 1ST GRIP
3	2	AC-61924	SKIN, 2 LAMP, 1600	27	6	AC-58833	TERMINAL, 3 POLE, CERAMIC, 600V
4	2	AC-59445	REFLECTOR, INNER, 2 LAMP, 1600	28	8	AC-50686-3	SCREW, CAP, SOCKET HD, 8-32 X 1.00
5	4	AC-64097	BRACKET, PIVOT, DUAL HEATER, 2 LAMP	30	24	AC-47799	# 8-32 SST MACH. NUT
6	1	AC-61231		31	4	39331	LAMP, IR, 1600W/240V, CER, CL, 19.70AL, 16.0L
7	50	AC-11799	SCREW, MACH, TRUSS, PH, 8-32 X .500, SST	32	25	AC-3887	# 10 EXTERNAL LOCK WASHER
8	25	AC-2455	# 10-32 X 3/4 TRUSS HEAD SCREW	33	2	AC-50686-1	PYROMETER SCREWS
9	4	AC-39917	3/8 STUD HANDLE	34	1	AC-42936	PYROMETER
10	2	AC-59449	REFLECTOR, OUTER, 2 LAMP, 1600	35	25	AC-4002	10-32 AVK, 1ST GRIP
11	4	AC-61923	INSULATOR, END COVER, 2 LAMP, 3" CTR	36	50	AC-200098-1	AVK, 1ST GRIP, # 8
12	4	AC-59463	COVER, END, 2 LAMP, 3" CENTER	37	8	AC-200097	RIVET, BLACK, ALUMINUM, # 43
13	1	AC-63210	COVER, SKIN, PRYO OPENING	38	50	AC-13938	WASHER, LOCK, EXTERNAL TOOTH, # 8, SST
14	37	AC-48081	WASHER, FLAT, 1/2" ID, SST	39	51"	AC-200048	WIRE 12 GAUGE
15	4	AC-50869	WASHER, 1.5 OD X .531 X .125 THK	41	4	AC-200108	8/32 GREEN SCREW
16	4	AC-54580	SPRING, COMPRESSION	42	2	AC-200192	GROUND WIRE
17	2	AC-64227	SPACER, "E" BRACKET	43	4	AC-200017	BLUE CABLE TIE
18	2	AC-54583	SPRING, COMPRESSION	44	4	AC-70476	NUT HEX MACH 6-32
19	6	AC-54585	PIN, COTTER, 1/8 X .750	45	4	AC-200018	4" WIRE 6-32
20	2	AC-63940	J-BOX, HEATER	46	4	AC-200091-1	SCREW 6-32
21	4	AC-64237	MOD, HEX BOLT, 1/2-13 X 2.00	50	2	AC-10142	8/3 - 3/8
22	2	AC-64238	MOD, HEX BOLT, 1/2-13 X 2.500	51	4	AC-200091-2	8/32 - 3/4
23	6	AC-39487	NUT, HEX, SLOTTED, 1/2-13	52	2	AC-61646	LAMP GAURD
24	1	AC-61657	PLATE, MOUNT, RAYTEC	53	2	AC-200099-1	8/32- 3/8 FLAT HD
				54	2	AC-200189	LABEL "CAUTION HOT"
				55	4	AC-200163	LABEL "CAUTION SHOCK"
				56	REF	AC-200019	LABEL "PINCH POINT"

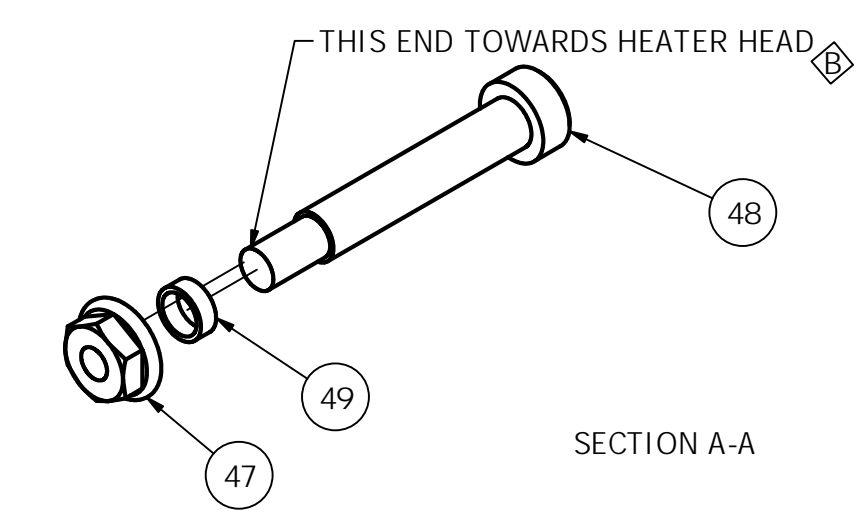

AC6			
Column 1	Column 2	Column 3	Column 4
ITEM	QTY	PART No.	DESCRIPTION
47	1	AC-3903	NUT HEX SERRATED 1/4-20
48	1	AC-200118-3	BOLT SHOULDER 5/16x1-1/2
49	1	AC-200183	WASHER SS ID. 26" OD. 325"

JOB NO	QTY	REL BY	ENG REL	SHOP	VENDER	P.O. NO	PROD REL	DUE
DRAWN: CTL		SCALE: 2 PLACE FRACT. .030 1/32		TOLERANCES 3 PLACE ANGULAR		THIS MATERIAL IS THE PROPERTY OF BGK FINISHING SYSTEMS IT MUST NOT BE COPIED OR ITS CONTENTS DISCLOSED WITHOUT AUTHORIZATION © 2002 BGK FINISHING SYSTEMS		
DATE: 6/13/2012		JOB NO:		MATERIAL:		ASSY, HEATER, 2216		
FINISH:		NEXT ASSY:		PART NO:		DRAWING NO: ACH6-2216		REV: C SHEET: 10F5

Technical drawing of a heater assembly with various views (Detail C, Detail D, Section A-A), a parts list, a revision history, and a drawing information block. The drawing includes callouts for components and assembly changes. The parts list details 56 items, including lamps, reflectors, brackets, screws, and electrical components. The revision history shows updates to the BOM and engineering notes. The drawing information block contains job number, quantities, dates, and material specifications.

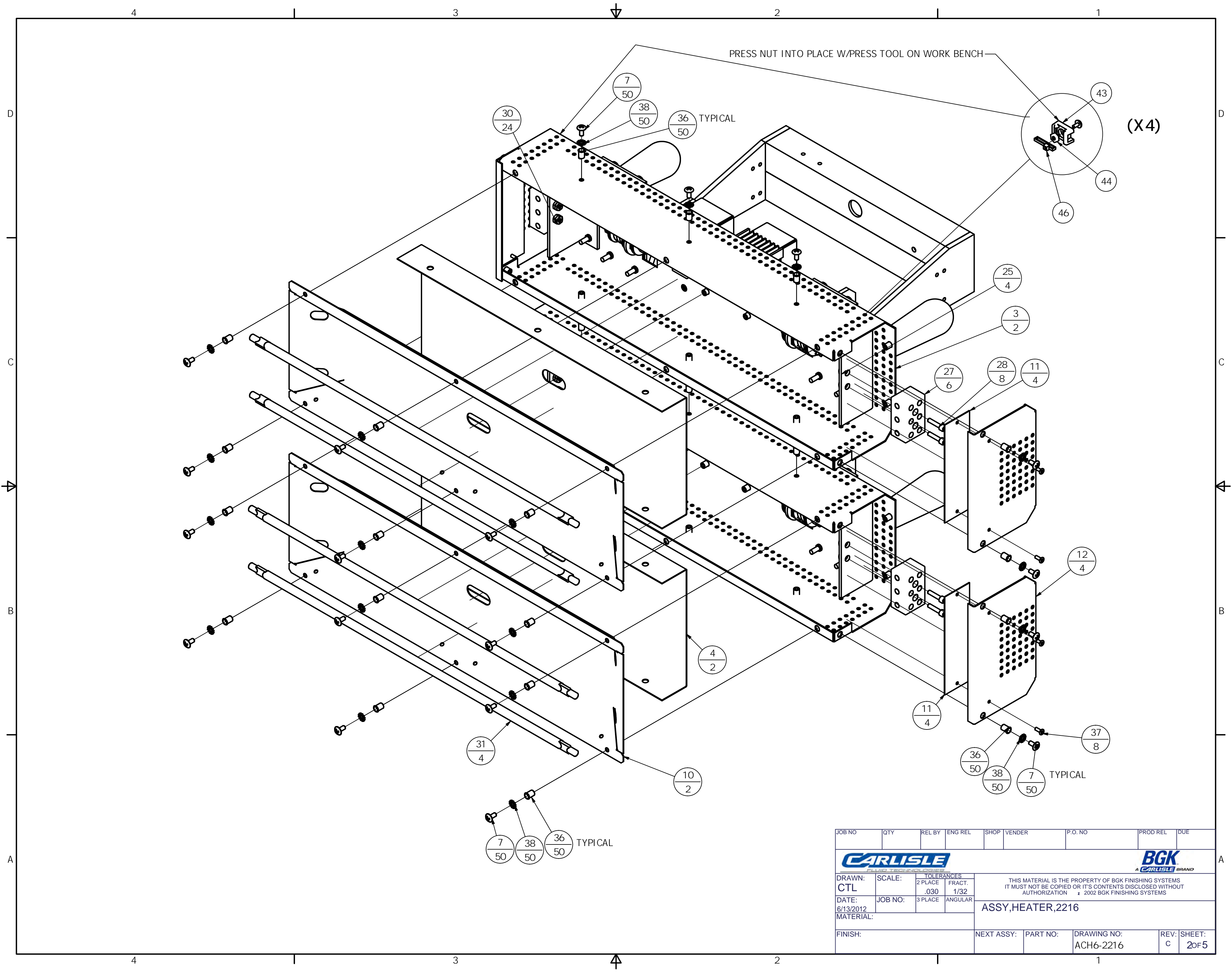

PRESS NUT INTO PLACE W/PRESS TOOL ON WORK BENCH

(X4)

JOB NO	QTY	REL BY	ENG REL	SHOP	VENDER	P.O. NO	PROD REL	DUE
DRAWN: CTL		SCALE: 2 PLACE FRACT. .030 1/32		TOLERANCES: 3 PLACE ANGULAR		THIS MATERIAL IS THE PROPERTY OF BGK FINISHING SYSTEMS IT MUST NOT BE COPIED OR IT'S CONTENTS DISCLOSED WITHOUT AUTHORIZATION © 2002 BGK FINISHING SYSTEMS		
DATE: 6/13/2012		JOB NO:		MATERIAL:		ASSY,HEATER,2216		
FINISH:		NEXT ASSY:		PART NO:		DRAWING NO: ACH6-2216		REV: C SHEET: 2of5



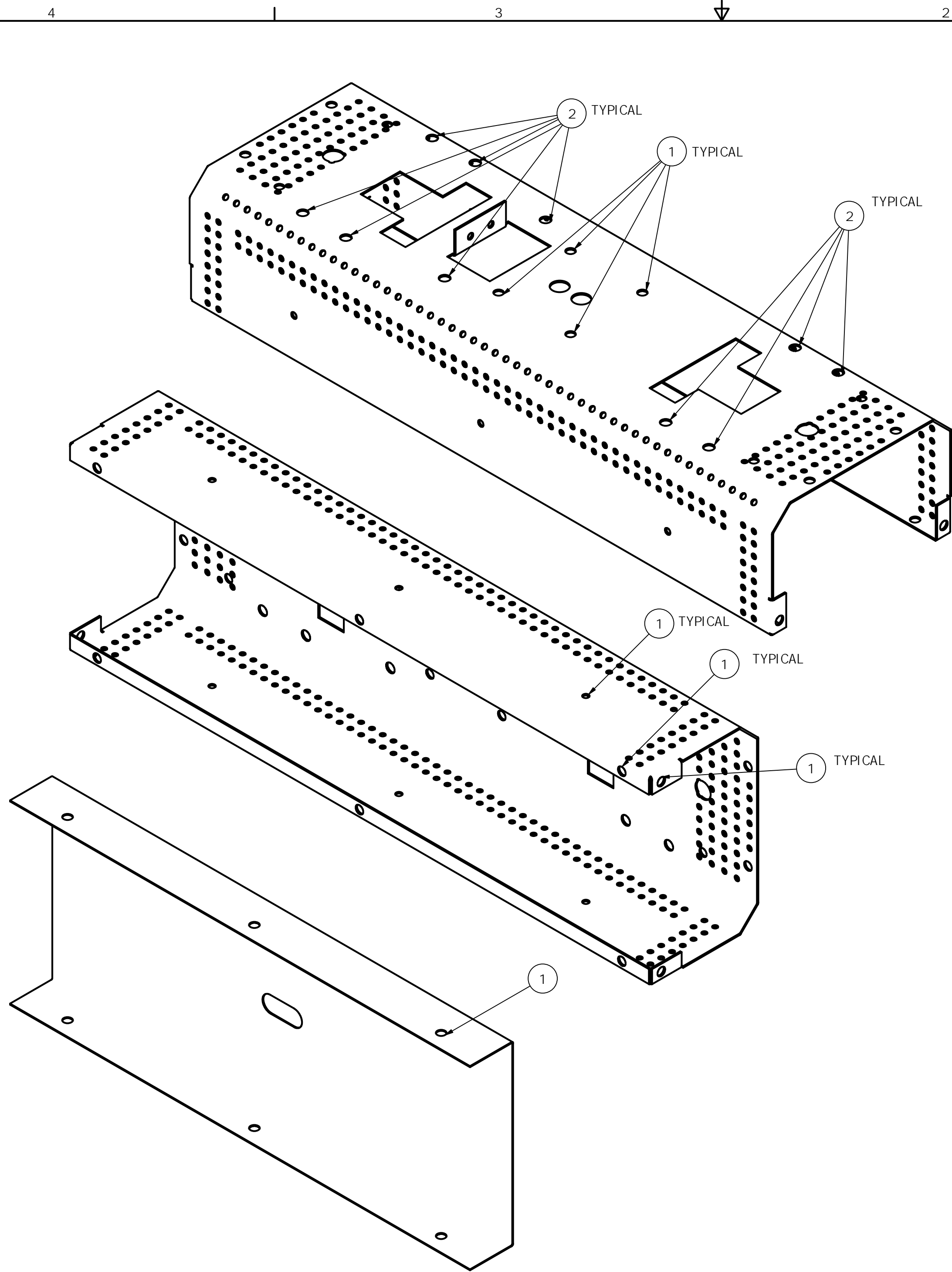

NUMBER	PART No.	DESCRIPTION
1	AC-200098-1	AVK 8/32
2	AC-4002	AVK 10/32
3	AC-200097	BLACK, RIVET
4	AC-4012	AVK 3/8

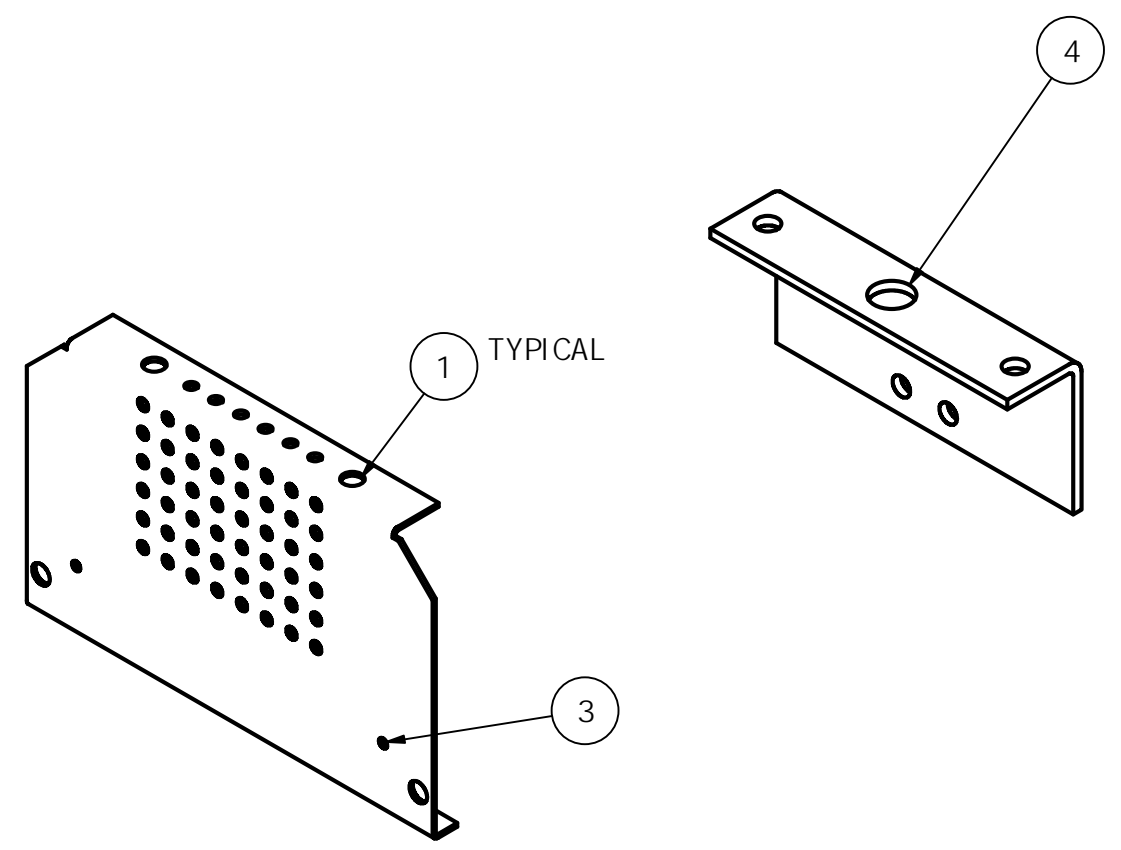

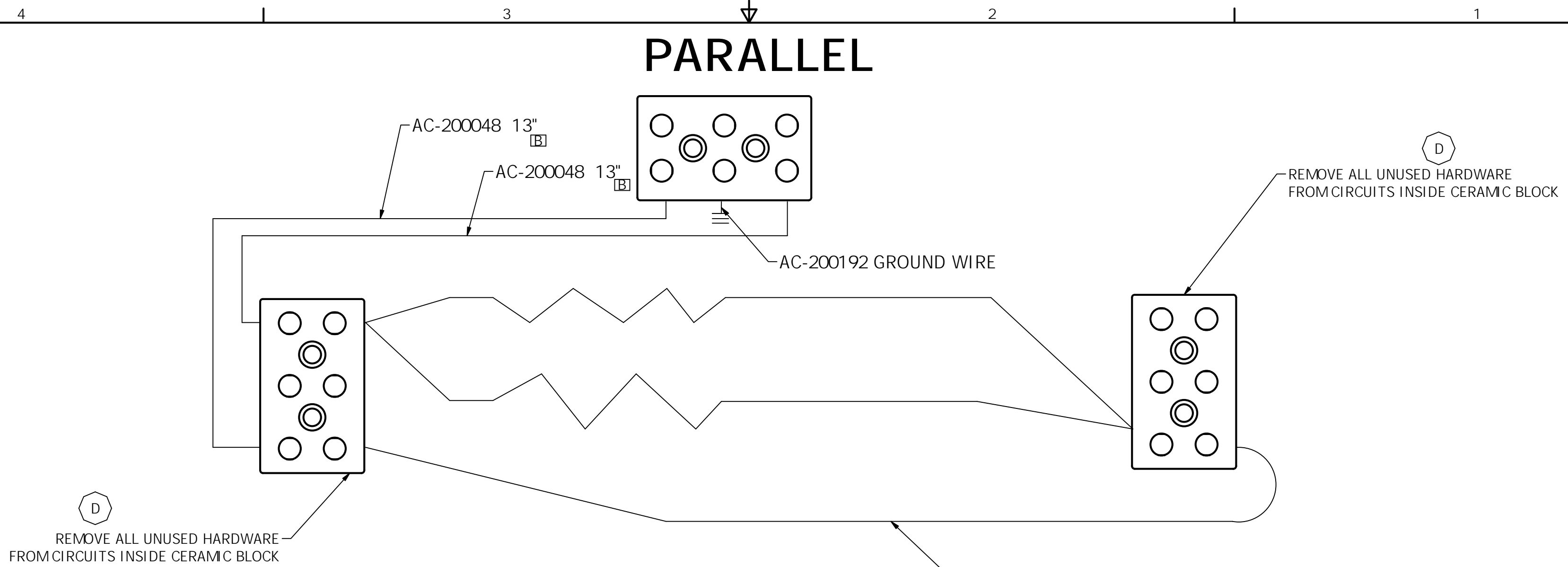

JOB NO	QTY	REL BY	ENG REL	SHOP	VENDER	P.O. NO	PROD REL	DUE
CARLISLE				BGK A CARLISLE BRAND				
DRAWN: CTL	SCALE:	TOLERANCES		THIS MATERIAL IS THE PROPERTY OF BGK FINISHING SYSTEMS IT MUST NOT BE COPIED OR ITS CONTENTS DISCLOSED WITHOUT AUTHORIZATION © 2002 BGK FINISHING SYSTEMS				
DATE: 6/13/2012	JOB NO:	2 PLACE .030	FRACT. 1/32					
MATERIAL:		3 PLACE	ANGULAR	COVER,END,2 LAMP,3" CENTER				
FINISH:	NEXT ASSY:	PART NO:	DRAWING NO: ACH6-2216	REV: C	SHEET: 3 of 5			

PARALLEL

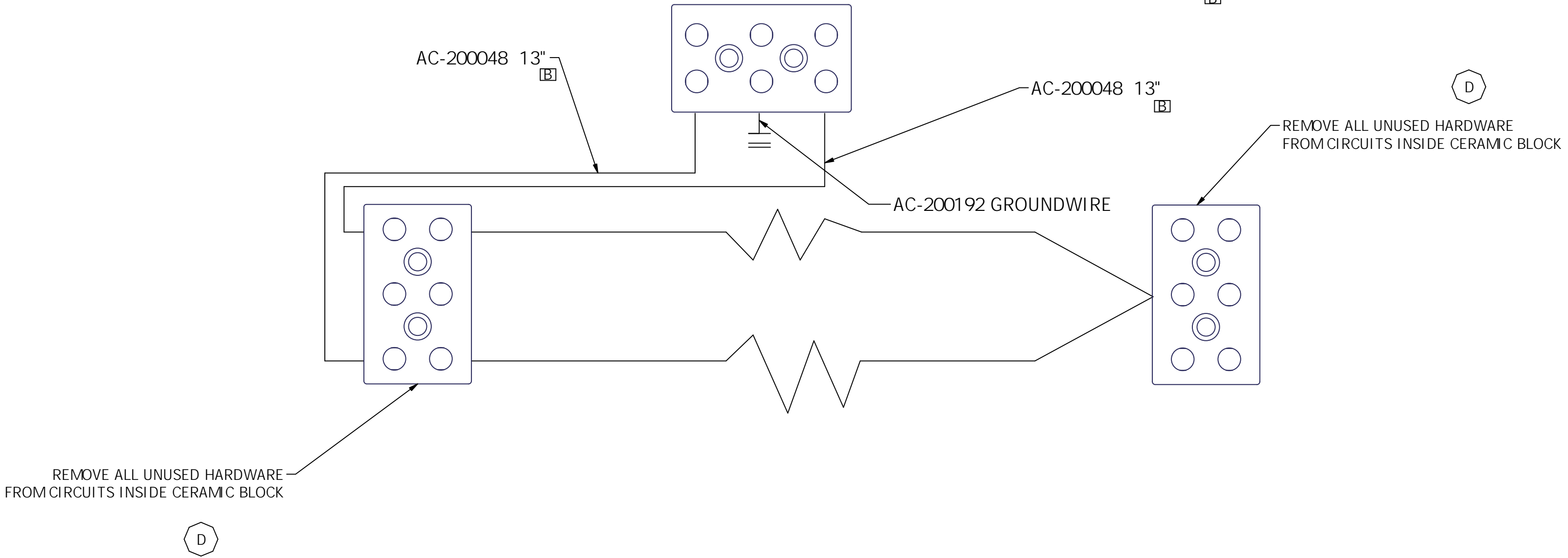

SERIES



JOB NO	QTY	REL BY	ENG REL	SHOP	VENDER	P.O. NO	PROD REL	DUE
 								
DRAWN: CTL	SCALE: 2 PLACE .030	TOLERANCES FRACT. 1/32 ANGULAR		THIS MATERIAL IS THE PROPERTY OF BGK FINISHING SYSTEMS IT MUST NOT BE COPIED OR ITS CONTENTS DISCLOSED WITHOUT AUTHORIZATION © 2002 BGK FINISHING SYSTEMS				
DATE: 6/13/2012	JOB NO: 	MATERIAL:		TERMINAL, 3 POLE, CERAMIC, 600V				
FINISH:	NEXT ASSY:	PART NO:	DRAWING NO: ACH6-2216	REV: C	SHEET: 4 of 5			

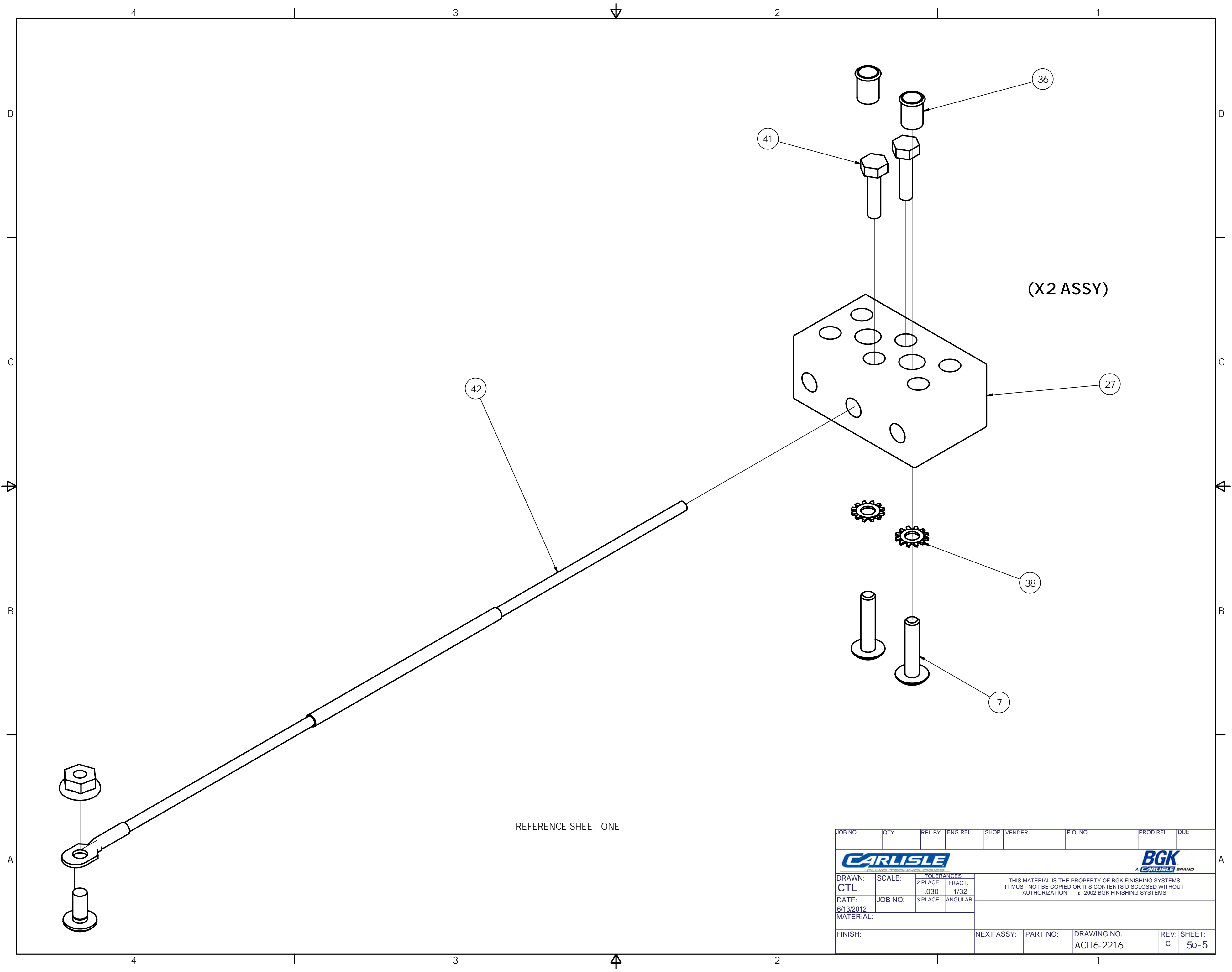

(X2 ASSY)

REFERENCE SHEET ONE

JOB NO	QTY	REL BY	ENG REL	SHOP	VENDER	P.O. NO	PROD REL	DUE
CARLISLE <small>FINISHING SYSTEMS</small>						BGK <small>A CARLISLE BRAND</small>		
DRAWN: CTL	SCALE:	TOLERANCES		THIS MATERIAL IS THE PROPERTY OF BGK FINISHING SYSTEMS IT MUST NOT BE COPIED OR IT'S CONTENTS DISCLOSED WITHOUT AUTHORIZATION © 2002 BGK FINISHING SYSTEMS				
DATE: 6/13/2012	JOB NO:	2 PLACE	FRACT.					
MATERIAL:		3 PLACE	ANGULAR					
FINISH:	NEXT ASSY:	PART NO:	DRAWING NO: ACH6-2216	REV: C	SHEET: 5 of 5			

RECOMMENDED SPARE PARTS

TO ORDER:

CONTACT: SPARE PARTS ORDER ENTRY

PHONE: 1-800-726-8097

E-MAIL: orderentry@CarlisleFT.com

AC6-2216-480-SP

Reference Number	Spares Qty	Part Number	Part Description
CON110, CON11	1	005898	CONTACTOR, 40A, 2-POLE, 24 COIL
FU105	4	E-178	FUSE,2A,600V,CLASS CC
FU109A, FU109B	4	AC-200046	FUSE,2A,250VAC,TIME DELAY
FU109C, FU109D	4	AC-200045	FUSE,10A,250VAC,TIME DELAY
FU101A, FU101B, FU104A, FU104B	4	AC-200042	FUSE, LOW PEAK CLASS CC, 10A
INST116	1	AC-74816-240-F-100	TEMP. CONTROLLER (Setup-100%, F deg, 240v)
PROX116	1	AC-200024	SWITCH, INDUCTIVE PROXIMITY
PWRSUP123	1	AC-46847	POWER SUPPLY,24VAC - 12VDC & 3.25VDC
SCR 103 FC	1	003317	Firing Circuit Board-PWR CTRLR,4-20MA,240V, 380V, 480V
SCR 103, SCR 104	1	002985	POWER CONTROLLER,SCR,40A, 240V, 380V, 480V
103	2	AC-200051	POWER CONTROLLER THERMSTRATE,H
CR110A, CR110B, CR116	1	062486	RELAY,1 PDT,24VDC/AC
	1	AC-200064	LASER KIT (Targeting laser only)
PYR 118	1	AC-61231	PYROMETER ASSEMBLY KIT (Complete)
Bridge 110	1	062001	RECTIFIER,BRIDGE,25A,50V
	1	AC-73709	ACTUATOR
SS114	1	064558	SELECTOR SW OP, 2 POS,MAINT
	2	AC-39917	HANDLE, PLASTIC, TAPERED 3/8-16
	1	AC-73841-8	PENDANT, 4-BUTTON, 8FT CABLE-Complete
	15FT	AC-62797	CABLE, SHIELD, 6 COND., RED
102	6	39331	Lamp,IR,1600W/240V

WARRANTY POLICY

This product is covered by Carlisle Fluid Technologies' materials and workmanship limited warranty. The use of any parts or accessories, from a source other than Carlisle Fluid Technologies, will void all warranties. Failure to reasonably follow any maintenance guidance provided, may invalidate any warranty.

For specific warranty information please contact Carlisle Fluid Technologies.

For technical assistance or to locate an authorized distributor, contact one of our international sales and customer support locations.

Region	Industrial / Automotive	Automotive Refinishing
Americas	Tel: 1-800-992-4657 Fax: 1-888-246-5732	Tel: 1-800-445-3988 Fax: 1-800-445-6643
Europe, Africa Middle East, India		Tel: +44 (0)1202 571 111 Fax: +44 (0)1202 573 488
China		Tel: +8621-3373 0108 Fax: +8621-3373 0308
Japan		Tel: +81 45 785 6421 Fax: +81 45 785 6517
Australia		Tel: +61 (0) 2 8525 7555 Fax: +61 (0) 2 8525 7575

For the latest information about our products, visit www.carlisleft.com

Carlisle Fluid Technologies is a global leader in innovative finishing technologies. Carlisle Fluid Technologies reserves the right to modify equipment specifications without prior notice.

BGK™, Binks®, DeVilbiss®, Hosco®, MS®, and Ransburg® are all registered trademarks of Carlisle Fluid Technologies, Inc.

©2020 Carlisle Fluid Technologies, Inc.
All rights reserved.

