

# RT-30SD

## Flow Transmitter with Local Display

Ideal for any industry or flow measurement application where a local rate and total display is required and in locations where equipment is exposed to the elements.

### Features:

- Available in single and dual access models
- Can be mounted directly on flow meter or in remote location
- HART® communication protocol option for remote monitoring and programming

### Benefits:

#### OPTIONS FOR REMOTE INDICATION

The RT-30 has options for remote flow monitoring:

- Frequency pulse output (standard)
- 4-20mA, user scalable (standard)
- HART communication protocol (optional)

#### EASY FIELD PROGRAMMING

Flow rate or total can be easily programmed to display in choice of engineering units. To change any key functions, simply use the magnet that is attached. No opening of the enclosure is required.

#### REMOTE MOUNTING AVAILABLE

The RT-30 can be mounted remotely when used in conjunction with any AW frequency output sensor.

#### UP AND RUNNING IN MINUTES

Easy thread-in installation. A quick setup procedure allows you to have the flow monitor working with just a few simple programming steps.

#### FLEXIBLE MOUNTING

Because of the integral swivel union, the RT-30 unit can be rotated 360° for optimal viewing from any angle. Options available to fit any AW Gear Meter or SABRE Turbine Meter.

#### WEATHER-PROOF ENCLOSURE

NEMA 4X enclosure provides environmental protection from moisture and debris.



### Technical Specifications:

- **Power Requirement:**  
9-24 VDC / 200mA (customer supplied)  
Class 2
- **Analog Output 4-20mA:**
  - PWM converter
  - 3- or 2-wire plus separate supply
  - Max load impedance 500 ohm
- **Frequency Output**
- **Three Opto-Isolated Open-Collector Outputs:**
  - Programmable for frequency or limit outputs
  - 5-30 VDC rating
  - 40 mA max (min. load impedance required 600 Ohm @ 30 VDC)
- **Built in 30 point Linearizer**
- **Sensor / Monitor Frequency Range:**  
0-4,500 Hz
- **Temperature Rating:**  
-20 to 60°C (-4 to 140°F)
- **Connection:**  
3/4" female NPT conduit provisions
- **One Opto-Isolated Input:**
  - 9-24 VDC remote reset

# RT-30SD

## Flow Transmitter with Local Display



### Monitor Dimensions:

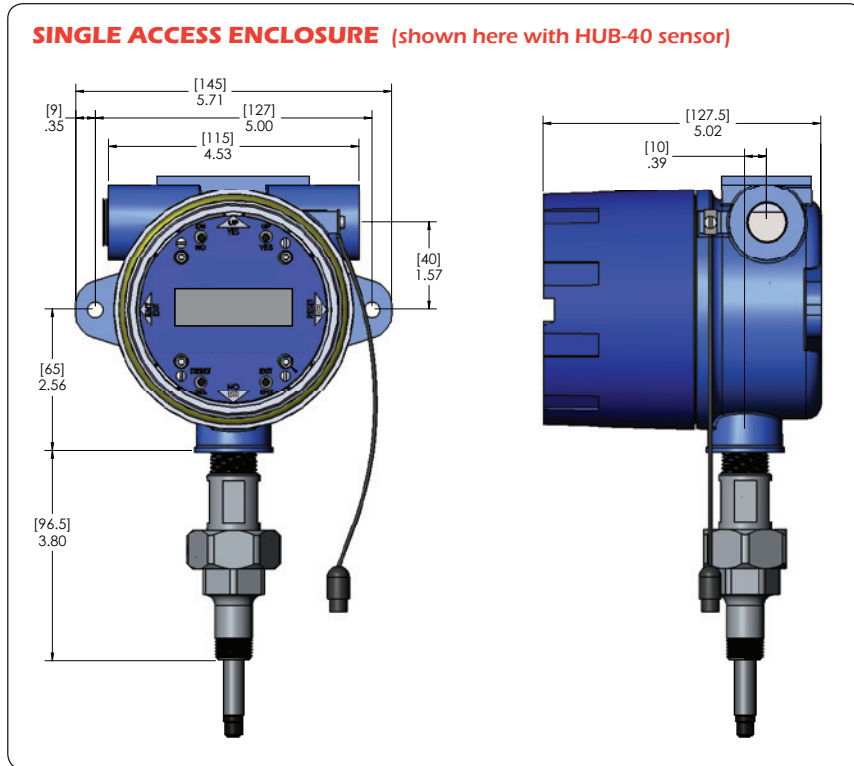

### Part Number Guide:

RT - 30SD -

**Enclosure style:**

- D = Dual access
- S = Single access
- T = Single access, 316 stainless steel

**Sensor:**

- 00 = None \*  
(Remote Mount)
- 02 = HUB-40SD1-S5-H2
- 11 = MAG-PB
- 31 = CAPM-15
- 41 = MG-300
- 42 = MG-450
- 81 = IR-PB

**Communication Protocol:**

- "blank" = none
- H = Hart®

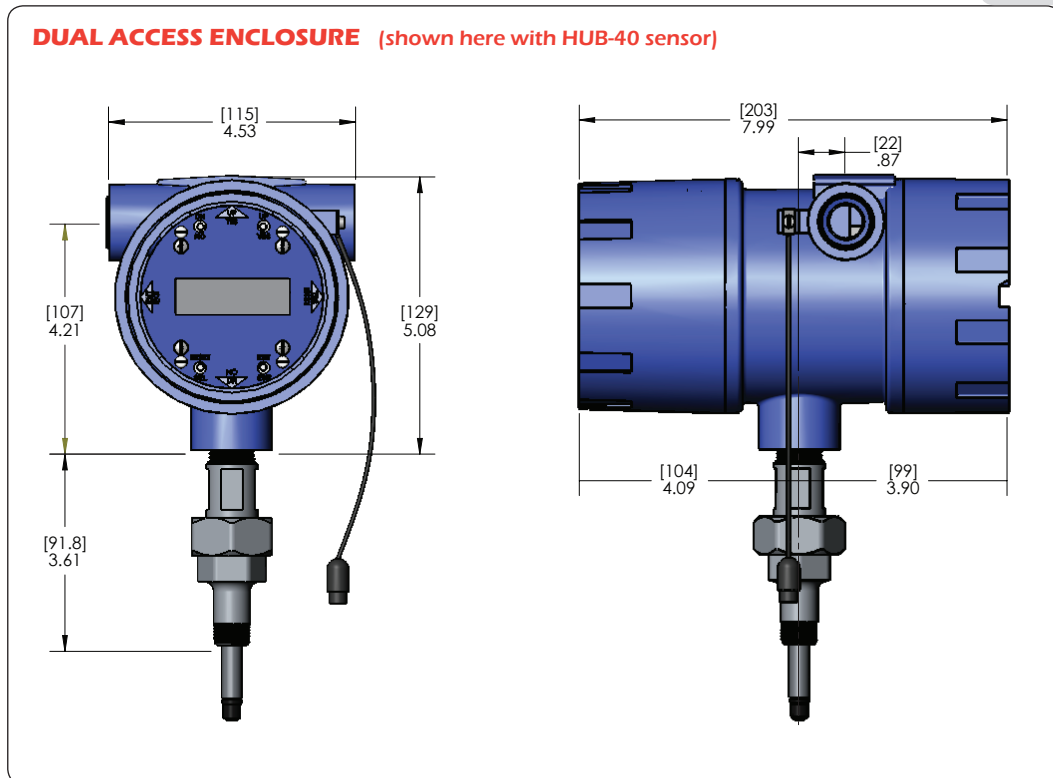

\* Requires external sensor

Products may be subject to change without notice - Contact factory for the most up-to-date product information.

**Contact  
AW Gear Meters:**

toll-free:  
**800-850-6110**

fax:  
**262-884-9810**

email:  
**awinfo@aw-lake.com**

website:  
**www.awgearmeters.com**