

AEROBELL™ 168



MODEL: 13350



IMPORTANT: Before using this equipment, carefully read SAFETY PRECAUTIONS, starting on page 1, and all instructions in this manual. Keep this Service Manual for future reference.

Service Manual Price: \$50.00 (U.S.)

NOTE: This manual has been changed from revision LN-9247-13 to revision LN-9247-13.1. Reasons for this change are noted under “Manual Change Summary” on page 110 of this manual.

CONTENTS

	PAGE
SAFETY:	1-5
SAFETY PRECAUTIONS	1
HAZARDS / SAFEGUARDS	2-5
ATEX:	6-13
EUROPEAN ATEX DIRECTIVE	6
LABELS	7
CONFIGURATION DRAWINGS.....	8-13
INTRODUCTION:	14-24
GENERAL DESCRIPTION	14
FEATURES	14
OPERATING CHARACTERISTICS AND SPECIFICATIONS	15-18
DIMENSIONAL CHARACTERISTICS.....	19-22
IMPORTANT NUMBERS.....	23
HOSE SPECIFICATIONS.....	24
INSTALLATION:	25-35
GENERAL INFORMATION	25
AIR FILTER INSTALLATION	25
HOSE SPECIFICATIONS.....	26
AIR FILTRATION REQUIREMENTS	27
TYPICAL MULTIPLE APPLICATOR CONFIGURATION	28-29
AIR HEATER REQUIREMENTS	30-31
FLUID CONNECTIONS.....	31-32
HIGH VOLTAGE CABLE ASSEMBLIES.....	33
HIGH VOLTAGE CABLE CONFIGURATIONS	33
AEROBELL 168 HIGH VOLTAGE CONNECT AT ATOMIZER END.....	33-34
AEROBELL 168 CASCADE CONNECTION	34-35
OPERATION:	36-40
TURBINE SPEED	36
BEARING AIR	37
BRAKE AIR.....	37
ELECTROSTATIC VOLTAGE.....	37
SHAPING AIRS	38
FLUID FLOW RATE CONTROL.....	38
FLUID TIP STREAM AND TIP STYLE USE	38-39
TARGET DISTANCE	39
MATERIAL CONDUCTIVITY	39
BELL CUPS.....	39
TURBINE AIR - NOTE.....	40
TURBINE EXHAUST AIR.....	40

(Continued on next page)

CONTENTS (Cont.)

	PAGE
MAINTENANCE:	41-81
O-RINGS	42-43
PREVENTIVE MAINTENANCE	43-45
AIR FILTERS / ELEMENT REPLACEMENT	45
BELL CUP CLEANINGS	46
CLEANING SHAPING AIR HOLES	47
AEROBELL 168 PREVENTIVE MAINTENANCE SCHEDULE	48
TOOLS REQUIRED TO DISASSEMBLE AEROBELL	49
OPTIONAL TOOLS REQUIRED TO DISASSEMBLE AEROBELL	50
DISASSEMBLY PROCEDURES (15MM BELL CUP)	51-56
DISASSEMBLY PROCEDURES (30MM BELL CUP)	57-61
DISASSEMBLY PROCEDURES (65MM BELL CUP)	62-70
DISASSEMBLY PROCEDURES (FOR ROBOT/MACHINE MOUNT KITS).....	71-81
PARTS IDENTIFICATION:	82-105
MODEL IDENTIFICATION	82-85
APPLICATOR PARTS BREAKDOWN / PARTS LIST	86-87
STUD MOUNT ASSEMBLY.....	88
MACHINE MOUNT KIT / PARTS LIST	89-91
ROBOT MOUNT KIT / PARTS LIST	92-94
CONFIGURATIONS	95-97
CABLES	98
HIGH VOLTAGE RESISTOR ASSEMBLY.....	99
EXTERNAL CASCADE COMPONENTS	99
ACCESSORIES	100
SERVICE KITS	101
RECOMMENDED SPARE PARTS	102-105
APPENDIX A:	106-108
TESTS OF THE STATIONARY EQUIPMENT	106-108
WARRANTY POLICIES:	109
LIMITED WARRANTY	109

SAFETY

SAFETY PRECAUTIONS

Before operating, maintaining or servicing any Ransburg electrostatic coating system, read and understand all of the technical and safety literature for your Ransburg products. This manual contains information that is important for you to know and understand. This information relates to USER SAFETY and PREVENTING EQUIPMENT PROBLEMS. To help you recognize this information, we use the following symbols. Please pay particular attention to these sections.

A WARNING! states information to alert you to a situation that might cause serious injury if instructions are not followed.

A CAUTION! states information that tells how to prevent damage to equipment or how to avoid a situation that might cause minor injury.

A NOTE is information relevant to the procedure in progress.

While this manual lists standard specifications and service procedures, some minor deviations may be found between this literature and your equipment. Differences in local codes and plant requirements, material delivery requirements, etc., make such variations inevitable. Compare this manual with your system installation drawings and appropriate Ransburg equipment manuals to reconcile such differences.

Careful study and continued use of this manual will provide a better understanding of the equipment and process, resulting in more efficient operation, longer trouble-free service and faster, easier troubleshooting. If you do not have the manuals and safety literature for your Ransburg system, contact your local Ransburg representative or Ransburg.



WARNING

- The user **MUST** read and be familiar with the Safety Section in this manual and the Ransburg safety literature therein identified.
- This manual **MUST** be read and thoroughly understood by **ALL** personnel who operate, clean or maintain this equipment! Special care should be taken to ensure that the **WARNINGS** and safety requirements for operating and servicing the equipment are followed. The user should be aware of and adhere to ALL local building and fire codes and ordinances as well as **NFPA-33 SAFETY STANDARD, LATEST EDITION**, prior to installing, operating, and/or servicing this equipment.



WARNING

- The hazards shown on the following pages may occur during the normal use of this equipment. Please read the hazard chart beginning on page 2.

<p>AREA Tells where hazards may occur.</p>	<p>HAZARD Tells what the hazard is.</p>	<p>SAFEGUARDS Tells how to avoid the hazard.</p>
<p>Spray Area</p> 	<p>Fire Hazard</p> <p>Improper or inadequate operation and maintenance procedures will cause a fire hazard.</p> <p>Protection against inadvertent arcing that is capable of causing fire or explosion is lost if any safety interlocks are disabled during operation. Frequent Power Supply or Controller shutdown indicates a problem in the system requiring correction.</p>	<p>Fire extinguishing equipment must be present in the spray area and tested periodically.</p> <p>Spray areas must be kept clean to prevent the accumulation of combustible residues.</p> <p>Smoking must never be allowed in the spray area.</p> <p>The high voltage supplied to the atomizer must be turned off prior to cleaning, flushing or maintenance.</p> <p>When using solvents for cleaning:</p> <ul style="list-style-type: none"> • Those used for equipment flushing should have flash points equal to or higher than those of the coating material. • Those solvents used for cleaning must have a flash point at minimum of 5°C (9°F) greater than the ambient temperature. It is the end users responsibility to insure this condition is met. <p>Spray booth ventilation must be kept at the rates required by NFPA-33, OSHA, country, and local codes. In addition, ventilation must be maintained during cleaning operations using flammable or combustible solvents.</p> <p>Electrostatic arcing must be prevented. Safe sparking distance must be maintained between the parts being coated and the applicator. A distance of 1 inch for every 10KV of output voltage is required at all times.</p> <p>Test only in areas free of combustible material. Testing may require high voltage to be on, but only as instructed.</p> <p>Non-factory replacement parts or unauthorized equipment modifications may cause fire or injury.</p> <p>If used, the key switch bypass is intended for use only during setup operations. Production should never be done with safety interlocks disabled.</p> <p>Never use equipment intended for use in waterborne installations to spray solvent based materials.</p> <p>The paint process and equipment should be set up and operated in accordance with NFPA-33, NEC, OSHA, local, country, and European Health and Safety Norms.</p>

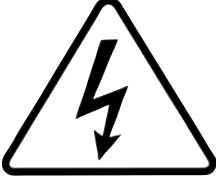
<p>AREA Tells where hazards may occur.</p>	<p>HAZARD Tells what the hazard is.</p>	<p>SAFEGUARDS Tells how to avoid the hazard.</p>
<p>Spray Area</p> 	<p>Explosion Hazard</p> <p>Improper or inadequate operation and maintenance procedures will cause a fire hazard.</p> <p>Protection against inadvertent arcing that is capable of causing fire or explosion is lost if any safety interlocks are disabled during operation.</p> <p>Frequent Power Supply or Controller shutdown indicates a problem in the system requiring correction.</p>	<p>Electrostatic arcing must be prevented. Safe sparking distance must be maintained between the parts being coated and the applicator. A distance of 1 inch for every 10KV of output voltage is required at all times.</p> <p>Unless specifically approved for use in hazardous locations, all electrical equipment must be located outside Class I or II, Division 1 or 2 hazardous areas, in accordance with NFPA-33.</p> <p>Test only in areas free of flammable or combustible materials.</p> <p>The current overload sensitivity (if equipped) MUST be set as described in the corresponding section of the equipment manual. Protection against inadvertent arcing that is capable of causing fire or explosion is lost if the current overload sensitivity is not properly set. Frequent power supply shutdown indicates a problem in the system which requires correction.</p> <p>Always turn the control panel power off prior to flushing, cleaning, or working on spray system equipment.</p> <p>Before turning high voltage on, make sure no objects are within the safe sparking distance.</p> <p>Ensure that the control panel is interlocked with the ventilation system and conveyor in accordance with NFPA-33, EN 50176.</p> <p>Have fire extinguishing equipment readily available and tested periodically.</p>
<p>General Use and Maintenance</p> 	<p>Improper operation or maintenance may create a hazard.</p> <p>Personnel must be properly trained in the use of this equipment.</p>	<p>Personnel must be given training in accordance with the requirements of NFPA-33, EN 60079-0.</p> <p>Instructions and safety precautions must be read and understood prior to using this equipment.</p> <p>Comply with appropriate local, state, and national codes governing ventilation, fire protection, operation maintenance, and housekeeping. Reference OSHA, NFPA-33, EN Norms and your insurance company requirements.</p>

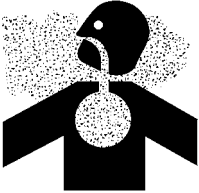
<p>AREA Tells where hazards may occur.</p>	<p>HAZARD Tells what the hazard is.</p>	<p>SAFEGUARDS Tells how to avoid the hazard.</p>
<p>Spray Area / High Voltage Equipment</p> 	<p>Electrical Discharge</p> <p>There is a high voltage device that can induce an electrical charge on ungrounded objects which is capable of igniting coating materials.</p> <p>Inadequate grounding will cause a spark hazard. A spark can ignite many coating materials and cause a fire or explosion.</p>	<p>Parts being sprayed and operators in the spray area must be properly grounded.</p> <p>Parts being sprayed must be supported on conveyors or hangers that are properly grounded. The resistance between the part and earth ground must not exceed 1 meg ohm. (Refer to NFPA-33.)</p> <p>Operators must be grounded. Rubber soled insulating shoes should not be worn. Grounding straps on wrists or legs may be used to assure adequate ground contact.</p> <p>Operators must not be wearing or carrying any ungrounded metal objects.</p> <p>When using an electrostatic handgun, operators must assure contact with the handle of the applicator via conductive gloves or gloves with the palm section cut out.</p> <p>NOTE: REFER TO NFPA-33 OR SPECIFIC COUNTRY SAFETY CODES REGARDING PROPER OPERATOR GROUNDING.</p> <p>All electrically conductive objects in the spray area, with the exception of those objects required by the process to be at high voltage, must be grounded. Grounded conductive flooring must be provided in the spray area.</p> <p>Always turn off the power supply prior to flushing, cleaning, or working on spray system equipment.</p> <p>Unless specifically approved for use in hazardous locations, all electrical equipment must be located outside Class I or II, Division 1 or 2 hazardous areas, in accordance with NFPA-33.</p>

AREA Tells where hazards may occur.	HAZARD Tells what the hazard is.	SAFEGUARDS Tells how to avoid the hazard.
<p>Electrical Equipment</p> 	<p>Electrical Discharge</p> <p>High voltage equipment is utilized in the process. Arcing in the vicinity of flammable or combustible materials may occur. Personnel are exposed to high voltage during operation and maintenance.</p> <p>Protection against inadvertent arcing that may cause a fire or explosion is lost if safety circuits are disabled during operation.</p> <p>Frequent power supply shut-down indicates a problem in the system which requires correction.</p> <p>An electrical arc can ignite coating materials and cause a fire or explosion.</p>	<p>Unless specifically approved for use in hazardous locations, the power supply, control cabinet, and all other electrical equipment must be located outside Class I or II, Division 1 and 2 hazardous areas in accordance with NFPA-33 and EN 50176.</p> <p>Turn the power supply OFF before working on the equipment.</p> <p>Test only in areas free of flammable or combustible material.</p> <p>Testing may require high voltage to be on, but only as instructed.</p> <p>Production should never be done with the safety circuits disabled.</p> <p>Before turning the high voltage on, make sure no objects are within the sparking distance.</p>
<p>Toxic Substances</p> 	<p>Certain material may be harmful if inhaled, or if there is contact with the skin.</p>	<p>Follow the requirements of the Material Safety Data Sheet supplied by coating material manufacturer.</p> <p>Adequate exhaust must be provided to keep the air free of accumulations of toxic materials.</p> <p>Use a mask or respirator whenever there is a chance of inhaling sprayed materials. The mask must be compatible with the material being sprayed and its concentration. Equipment must be as prescribed by an industrial hygienist or safety expert, and be NIOSH approved.</p>
<p>Spray Area</p> 	<p>Explosion Hazard – Incompatible Materials</p> <p>Halogenated hydrocarbon solvents for example: methylene chloride and 1,1,1,-Trichloroethane are not chemically compatible with the aluminum that might be used in many system components. The chemical reaction caused by these solvents reacting with aluminum can become violent and lead to an equipment explosion.</p>	<p>Aluminum is widely used in other spray application equipment - such as material pumps, regulators, triggering valves, etc. Halogenated hydrocarbon solvents must never be used with aluminum equipment during spraying, flushing, or cleaning. Read the label or data sheet for the material you intend to spray. If in doubt as to whether or not a coating or cleaning material is compatible, contact your coating supplier. Any other type of solvent may be used with aluminum equipment.</p>

EUROPEAN ATEX DIRECTIVE 94/9/EC, ANNEX II, 1.0.6

The following instructions apply to equipment covered by certificate number Sira 13ATEX5176X:

1. The equipment may be used with flammable gases and vapors with apparatus groups II and with temperature class T6.

2. The equipment is only certified for use in ambient temperatures in the range +0°C to +40°C and should not be used outside this range.

3. Installation shall be carried out by suitably trained personnel in accordance with the applicable code of practice e.g. EN 60079-14:1997.

4. Inspection and maintenance of this equipment shall be carried out by suitably trained personnel in accordance with the applicable code of practice e.g. EN 60079-17.

5. Repair of this equipment shall be carried out by suitable trained personnel in accordance with the applicable code of practice e.g. EN 60079-19.

6. Putting into service, use, assembling, and adjustment of the equipment shall be fitted by suitably trained personnel in accordance with the manufacturer's documentation.

Refer to the "Table of Contents" of this service manual:

- a. Installation
- b. Operation
- c. Maintenance
- d. Parts Identification

7. Components to be incorporated into or used as replacement parts of the equipment shall be fitted by suitably trained personnel in accordance with the manufacturer's documentation.

8. The certification of this equipment relies upon the following materials used in its construction:

If the equipment is likely to come into contact with aggressive substances, then it is the responsibility of the user to take suitable precautions that prevent it from being adversely affected, thus ensuring that the type of protection provided by the equipment is not compromised.

Aggressive substances: e.g. acidic liquids or gases that may attack metals, or solvents that may affect polymeric materials.

Suitable precautions: e.g. regular checks as part of routine inspections or establishing from the material's data sheets that it is resistant to specific chemicals.

Refer to "Specifications" in the "Introduction" section:

- a. All fluid passages contain stainless steel, nylon fittings or chemically compatible resins.
- b. High voltage cascade is encapsulated in di-electric oil.

9. A recapitulation of the certification marking is detailed in the "ATEX" section, on the next page, drawing numbers: 80108, A13349, A13383, A13384.

10. The characteristics of the equipment shall be detailed e.g. electrical, pressure, and voltage parameters.

The manufacturer should note that, on being put into service, the equipment must be accompanied by a translation of the instructions in the language or languages of the country in which the equipment is to be used and by the instructions in the original language.

AB168 A13350 ATEX PRODUCT MARKING DEFINITIONS

Ex Certificate Number: Sira 13ATEX5176X
 Sira = Notified Body performing EC-type examination
 13 = Year of certification
 ATEX = Reference to ATEX Directive
 5 = Protection Concept Code (code 5 is titled Encapsulation)
 176 = Document serial number
 X = Special conditions for safe use apply

Product Marking

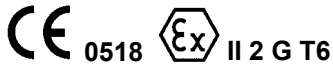

Ex = Specific marking of explosive protection
 II = Equipment Group hazardous area characteristics
 2 = Equipment Category
 G = Type of explosive atmosphere (gases, vapors, or mists)
 T6 = Temperature classification.

Power Supply Marking

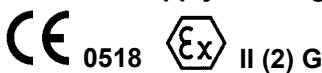

Special conditions for safe use:

- The AB168, Applicator shall only be used with associated 80120-51X or 80100-51X 9060 Power Supply according to configuration drawing A13351.
- The safe Distance of use for the Type AB168 Electrostatic Bell is 204mm minimum; from the electrode to earthed parts. The end user must ensure this distance, as a minimum is maintained and that grounded objects are prevented from contacting the applicator bell cup when the applicator is energized or operating.
- The 9060 and external cascade is intended for "Safe Area Use" only.
- The AB168 Electrostatic Bell is a potential hazard - refer to the manufacturers instructions.
- The end user must insure that installation is in accordance with all applicable requirements of EN 50 176. This includes the means of fire protection and fire detection being installed with this system.
- Before servicing bell insure that all voltage is completely de-energized and the bell cup is not rotating. Minimum 1 minute wait after turbine air has been shut off.
- If ignitable fluids are used for cleaning purposes, all parts must be completely discharged of high voltage.
- The fluid supply system must be properly grounded.

- If an object is within the 204mm safe distance, it must be cleared prior to restarting and/or re-energizing the system.
- The materials used in the construction of this equipment contain levels of Al, Mg, Ti and Zi that are greater than that allowed for EPL Ga and Gb by clause 8.3 of EN 60079-0, therefore in rare cases, ignition sources due to impact and friction sparks could occur. The equipment shall therefore be protected from such impact and friction when installed.
- The type AB168 Electrostatic Bell and type 9060 (80120-51X or 80100-51X) power supply complies with EN 50 176: 2009. Clauses 4, 5.1, 5.2.1, 5.2.2, 5.2.3, 5.2.4, 5.3, 5.5.1, 5.5.3, 5.5.5, 5.6, 6.1, 6.4, 7.2, 7.3 and 7.4. All remaining clauses of EN 50 176: 2009 are to be addressed during installation.
- The installer shall fix the warning sign that is supplied with these products in a position close to the equipment; in addition, it shall also be clearly visible to the operator.

Ransburg BRAND OF FINISHING BRANDS HOLDINGS INC., TOLEDO, OH.		CONTROL UNIT/POWER SUPPLY FOR ELECTROSTATIC PAINT FINISHING APPLICATIONS OF ALL VOLTAGE RANGES	
WARNING FAILURE TO OBSERVE THE FOLLOWING PRECAUTIONS MAY RESULT IN AN ELECTRICAL DISCHARGE CAPABLE OF STARTING A FIRE.			
1. THE ARTICLE BEING COATED MUST BE GROUNDED. 2. ALL OTHER ELECTRICALLY CONDUCTING OBJECTS WITHIN SPRAY BOOTH WITH THE SPRAY APPLICATOR MUST BE GROUNDED. 3. THIS CONTROL UNIT/POWER SUPPLY MUST BE INTERLOCKED WITH THE SPRAY BOOTH VENTILATORS SO AS TO PREVENT OPERATION OF THE POWER SUPPLY UNLESS VENTILATING FANS ARE IN OPERATION. 4. SERVICE WARNING: ENCLOSURE PROTECTS AGAINST SHOCK AND INJURY. SERVICE TRAINING REQUIRED. 5. KEEP POWER SUPPLY OUTSIDE THE HAZARDOUS AREA. 6. DO NOT ATTEMPT OPERATION OR REPAIR BEFORE READING SERVICE MANUAL. 7. FOR ELECTROSTATIC PAINT FINISHING APPLICATIONS.			
PART No. INPUT VOLTAGE FREQUENCY VOLTAGES HUMIDITY INPUT PREPARE	100-240 VAC 50/60 Hz 110 VA MAX 270 V MAX CONDENSING 100 PSI MAX	1 A MAX. 1 90VDC 80% RH 0-40°C SA	SERIAL No. INPUT AND OUTPUT PHASES MAXIMUM VOLTAGE MAXIMUM CURRENT TEMPERATURE
			LABEL REMOVAL VOID WARRANTY

80108

APPROVED FOR USE IN FINISHING LOCATIONS WHEN CONFIGURED ACCORDING TO DRAWING A13351-00 AND ALL CONDITIONS FOR SAFE USE HAVE BEEN MET. CONSULT MANUAL FOR FURTHER INFORMATION.
 REFERENCE MANUAL LN-9247-13
 SIRA 13ATEX5176X

A13383

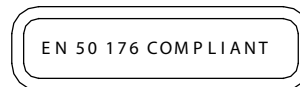

A13384



A13349

Configurations

These applicators are approved when configured to drawings shown on pages 8 thru 13.

CONFIGURATION DRAWING A13351

ORDERING INSTRUCTIONS:

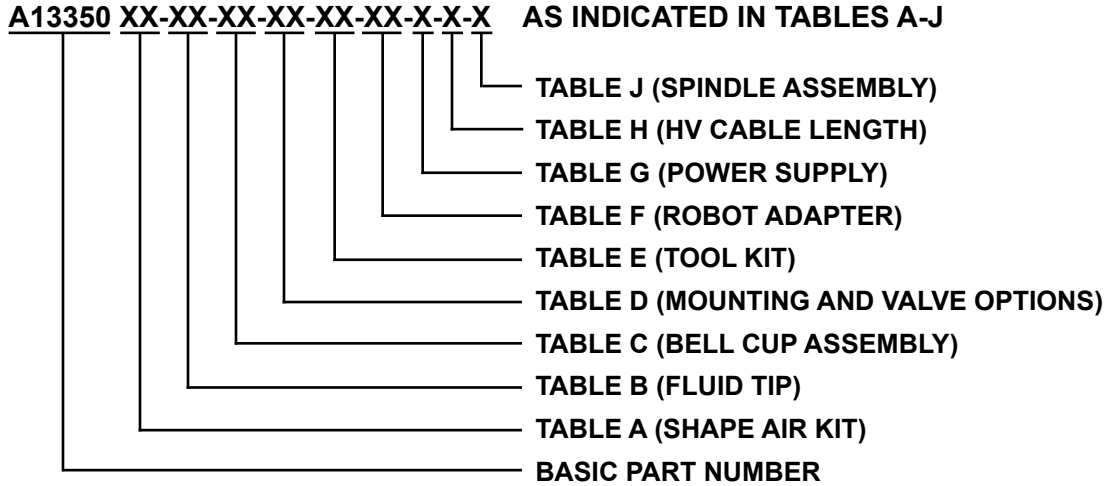
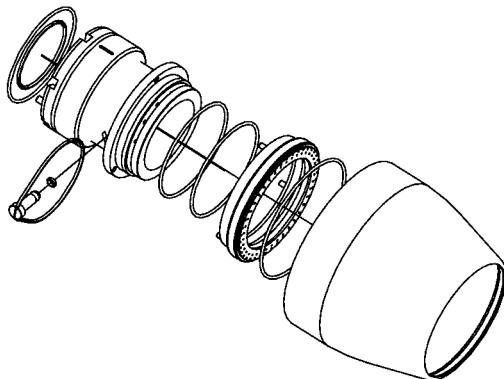
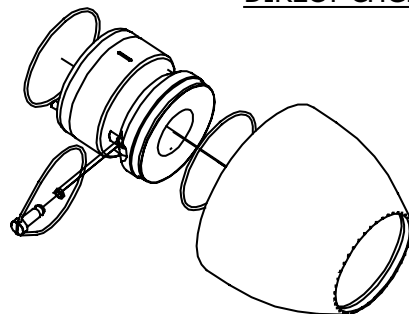

TABLE A - SHAPE AIR KIT

Dash #	Part #	Description
01	A13032-01	DUAL FLEX (DUAL SHAPE AIR) - DIRECT CHARGE
02	A13032-02	MONO FLEX (SINGLE SHAPE AIR)-DIRECT CHARGE
03	A13032-03	30MM (DUAL SHAPE AIR) - DIRECT CHARGE
07	A13206-00	DUAL SHAPE AIR, 15MM, DIRECT CHARGE



A13032-01
DUAL FLEX
DIRECT CHG.



A13032-02
MONO FLEX
DIRECT CHG.

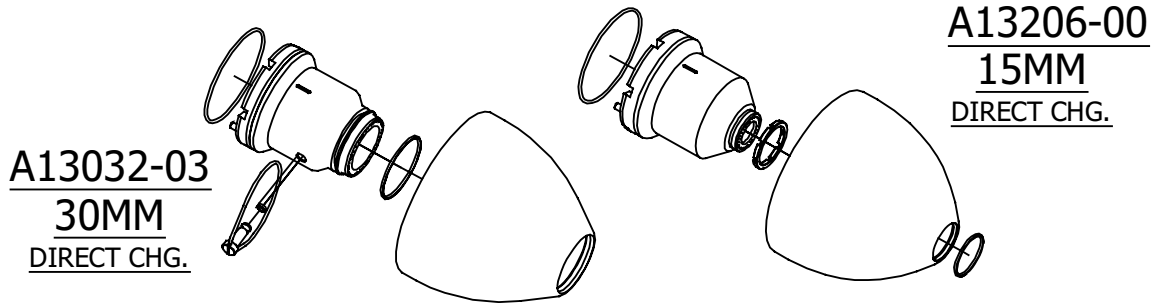
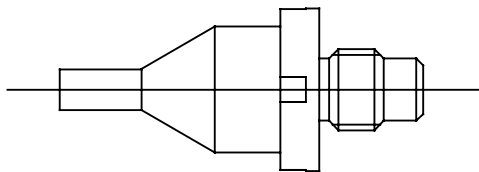
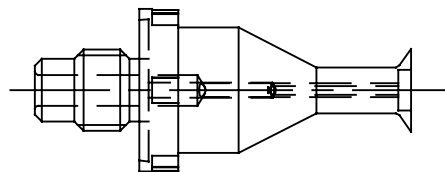

TABLE B - FLUID TIP

Part #	Description	Qty.	Part #	Description	Qty.
A11240-01	.028/0.7MM	1	A13625-06	.093/2.4mm Straight	1
A11240-02	.035/0.9mm	1	A13625-07	.125/3.2mm Straight	1
A11240-03	.043/1.1mm	1	A13625-08	.010/0.25mm Straight	1
A11240-04	.047/1.2mm	1	A13645-00	.028/0.7MM Industrial	1
A11240-05	.062/1.6mm	1	A13645-01	.035/0.9mm Industrial	1
A11240-06	.039/1.0mm	1	A13645-02	.039/1.0mm Industrial	1
A13601-00	.010/0.25mm	1	A13645-03	.043/1.1mm Industrial	1
A13625-00	.028/0.7MM Straight	1	A13645-04	.047/1.2mm Industrial	1
A13625-01	.035/0.9mm Straight	1	A13645-05	.062/1.6mm Industrial	1
A13625-02	.039/1.0mm Straight	1	A13645-06	.093/2.4mm Industrial	1
A13625-03	.043/1.1mm Straight	1	A13645-07	.125/3.2mm Industrial	1
A13625-04	.047/1.2mm Straight	1	A13645-08	.010/0.25mm Industrial	1
A13625-05	.062/1.6mm Straight	1			



**A11240
A13625**



A13645

TABLE C - BELL CUP ASSEMBLY

Dash #	Part #	Description	Bell Cup Only (Ref.)	Splash Plate Only (Ref.)
01	A12942-02	65MM ALUMINUM, PLATED	A12782-00	A13644-00
02	A12833-01	30MM ALUMINUM, PLATED	A12832-00	A13274-00
03	A13207-00	15MM TITANIUM	A12936-00	---
04	A12833-03	30MM TITANIUM	A13531-00	A13274-00
05	A13676-00	65MM TITANIUM	A13675-00	A13644-00

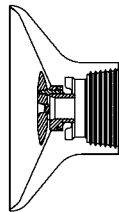

A12942-02

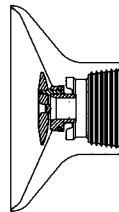

A13676-00

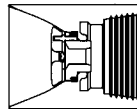

A12833-01

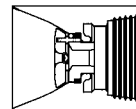

A12833-03

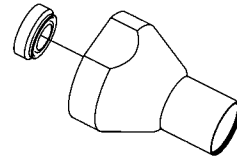

A13207-00

TABLE D - MOUNTING AND VALVE OPTIONS

Dash #	Part #	Description
01	A13033-00	STUD MOUNT ONLY, NO VALVES, WITH REMOTE CUP WASH MANIFOLD
02	A13401-01	MACHINE MOUNT WITH TRIGGER, DUMP, CUP WASH SOLVENT VALVES WITH 79879-00 FLUID COIL (16 COILS 1/4 O.D. X 1/8 I.D.) 8 X 6 PAINT FITTING
03	A13401-02	MACHINE MOUNT WITH TRIGGER, DUMP, CUP WASH SOLVENT VALVES WITH 79879-01 FLUID COIL (12 COILS 1/4 O.D. X 1/8 I.D.) 8 X 6 PAINT FITTING
04	A13402-00	ROBOT MOUNT WITH TRIGGER, DUMP, CUP WASH SOLVENT VALVES WITH 79879-00 FLUID COIL (16 COILS 1/4 O.D. X 1/8 I.D.) 8 X 6 PAINT FITTING
05	A13402-01	ROBOT MOUNT WITH TRIGGER, DUMP, CUP WASH SOLVENT VALVES WITH 79879-01 FLUID COIL (12 COILS 1/4 O.D. X 1/8 I.D.) 8 X 6 PAINT FITTING
06	A13401-03	MACHINE MOUNT WITH TRIGGER, DUMP, CUP WASH SOLVENT VALVES WITH 79879-00 FLUID COIL (16 COILS 1/4 O.D. X 1/8 I.D.) 8 X 5 PAINT FITTING
07	A13401-04	MACHINE MOUNT WITH TRIGGER, DUMP, CUP WASH SOLVENT VALVES WITH 79879-01 FLUID COIL (12 COILS 1/4 O.D. X 1/8 I.D.) 8 X 5 PAINT FITTING
08	A13402-03	ROBOT MOUNT WITH TRIGGER, DUMP, CUP WASH SOLVENT VALVES WITH 79879-00 FLUID COIL (16 COILS 1/4 O.D. X 1/8 I.D.) 8 X 5 PAINT FITTING
09	A13402-04	ROBOT MOUNT WITH TRIGGER, DUMP, CUP WASH SOLVENT VALVES WITH 79879-01 FLUID COIL (12 COILS 1/4 O.D. X 1/8 I.D.) 8 X 5 PAINT FITTING

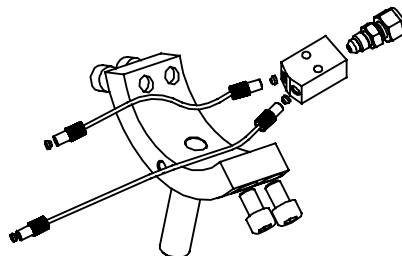

A13033-00

A13352 Configuration Drawing

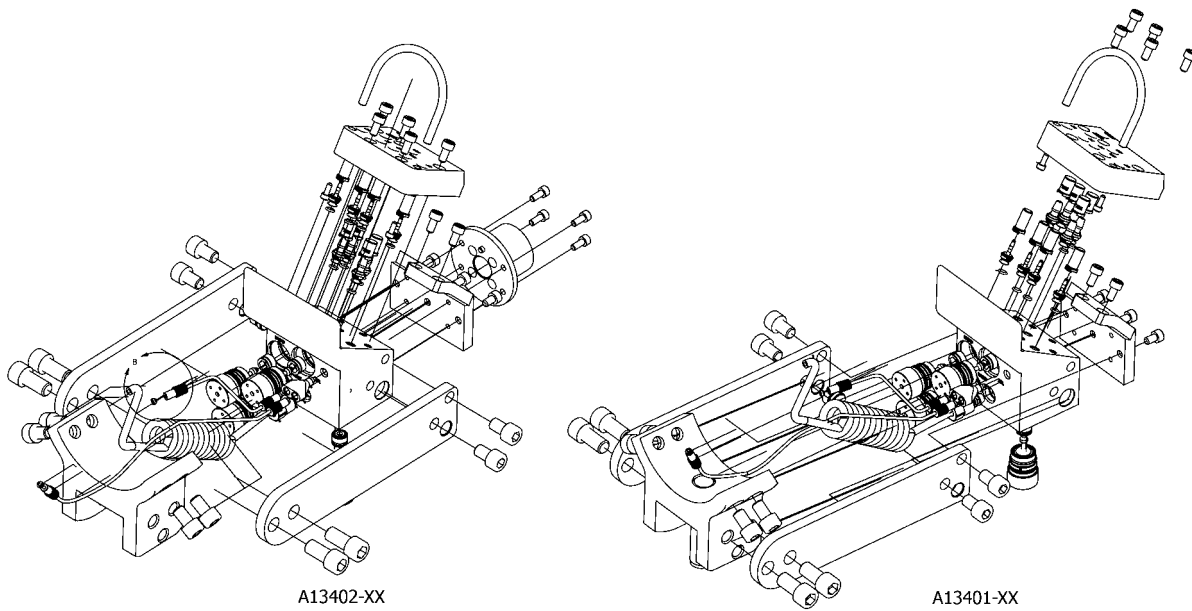
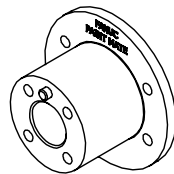

TABLE E - TOOL KIT

Dash #	Part #	Tool Kit Includes	Description
01	---	---	NO TOOL KIT
02	A13082-01	RPM-419, A12899-00, A11229-00, A12088-00, A11388-00, 59972-00	POST MOUNT APPLICATOR WITH 30MM OR 65MM BELL CUP
03	A13082-02	RPM-419, A12899-00, A11229-00, A12088-00, A11388-00, A11922-00, A10766-00, 59972-00	APPLICATOR WITH 30MM OR 65MM BELL CUP WITH VALVE PACKAGE
04	A13082-03	RPM-419, A11229-00, A12088-00, A12939-00, 59972-00	POST MOUNT APPLICATOR WITH 15MM
05	A13082-04	RPM-419, A11229-00, A12088-00, A12939-00, A11922-00, A10766-00, 59972-00	APPLICATOR WITH 15MM BELL CUP WITH VALVE PACKAGE

TABLE F - ROBOT ADAPTER

Dash #	Part #	Description
01	NONE	NONE
02	A13031-00	FANUC PAINT MATE



A13031-00

TABLE G - POWER SUPPLY		
Dash #	Description	Part #
-0	NO POWER SUPPLY	---
-1	DOMESTIC 10" RACK	80120-511
-2	EUROPE 10" RACK	80120-512
-3	CHINA 10" RACK	80120-513
-4	DOMESTIC BOX STYLE	80100-511
-5	EUROPE BOX STYLE	80100-512
-6	CHINA BOX STYLE	80100-513

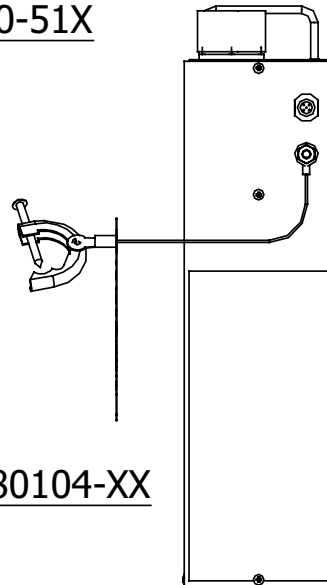
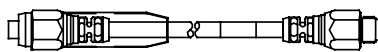
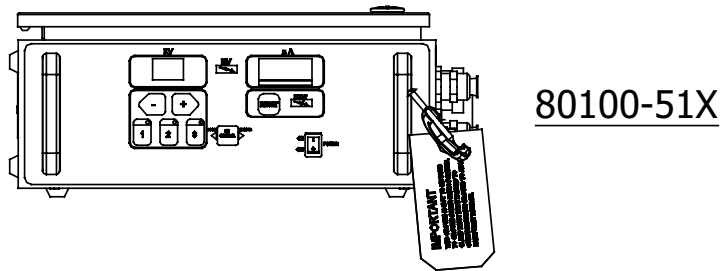
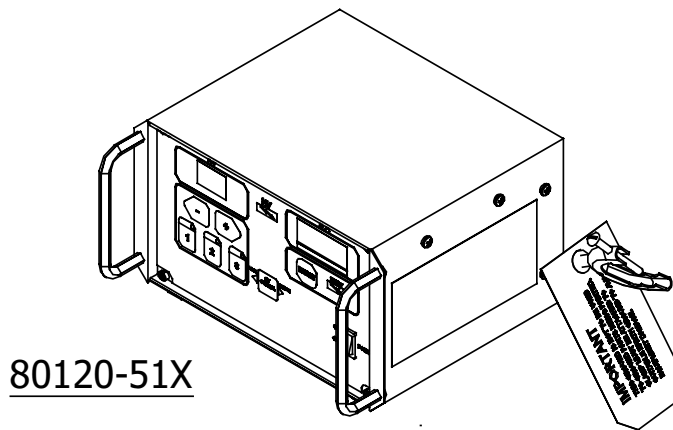

A13352 Configuration Drawing

TABLE H - HIGH VOLTAGE CABLE

Dash #	Description	Part #
-0	NO CABLE	---
-1	HIGH VOLTAGE CABLE -15' (4.5m)	A13386-15
-2	HIGH VOLTAGE CABLE -25' (7.6m)	A13386-25
-3	HIGH VOLTAGE CABLE -50' (15.2m)	A13386-50
-4	HIGH VOLTAGE CABLE -15' (4.5m)	A13348-15
-5	HIGH VOLTAGE CABLE -25' (7.6m)	A13348-25
-6	HIGH VOLTAGE CABLE -50' (15.2m)	A13348-50

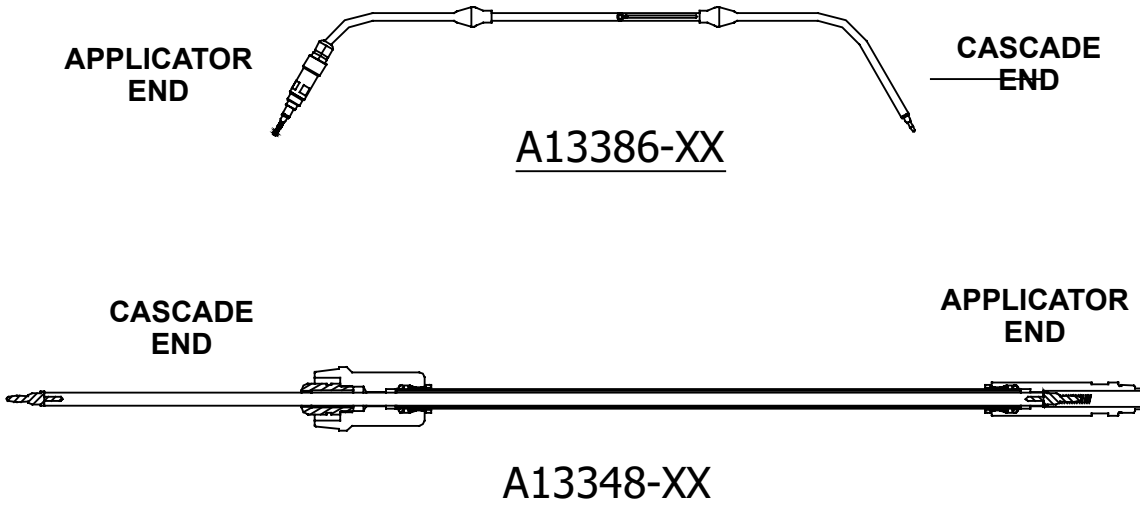

TABLE J - (SPINDLE ASSEMBLY)

Dash #	Part "P"	Description
-0	NONE	NONE
-1	A12777-00	SILVER SHAFT STYLE
-2	A12777-02	BLACK SHAFT STYLE

Other Atex Requirements

- Foot wear worn by the operator shall comply with EN ISO 20344, the measured insulation resistance shall not exceed 100 MΩ.
- Protective clothing including gloves shall comply with EN 1149-5, the measured insulation resistance shall not exceed 100 MΩ.

A13352 Configuration Drawing

INTRODUCTION

GENERAL DESCRIPTION

The Ransburg Aerobell 168 is a high speed bell type atomizer for electrostatic applications of conventional and high solids coating materials. It is available in several configurations. Contact your Ransburg representative for assistance in atomizer bell selection.

The Aerobell 168 turbine assembly incorporates precision air type bearings for extended turbine life.

FEATURES

Features which make the Aerobell 168 advantageous for use in rotary atomizer electrostatic applications include:

- Fast color change due to center feed fluid delivery and integral air brake
 - Sleek configuration to facilitate cleaning of the exterior
 - Braking air capability
 - Field repairable turbine assembly after the warranty period
 - Machine mountable
 - Non-hollow wrist robot mountable
 - 30mm dual shape air configuration for optimum pattern control
 - 65mm Mono Flex and Dual Flex shaping air configuration for optimum pattern control
 - 15mm Titanium bell cups are available. 30 and 65mm Bell cups are electroless nickel coated Aluminum and Titanium
- Proven long life air bearing spindle
 - Speed control: This unit has flexibility in speed sensing capability. Both magnetic and light sensing for speed reading and control can be utilized
 - Internal and external bell cup wash capability
 - Lightweight
 - Atex approved when properly configured.
 - Power supply has di/dt function to shut down if current of the system rises too quickly.
 - Power supply may be controlled either locally or remotely by PLC or other control feature.

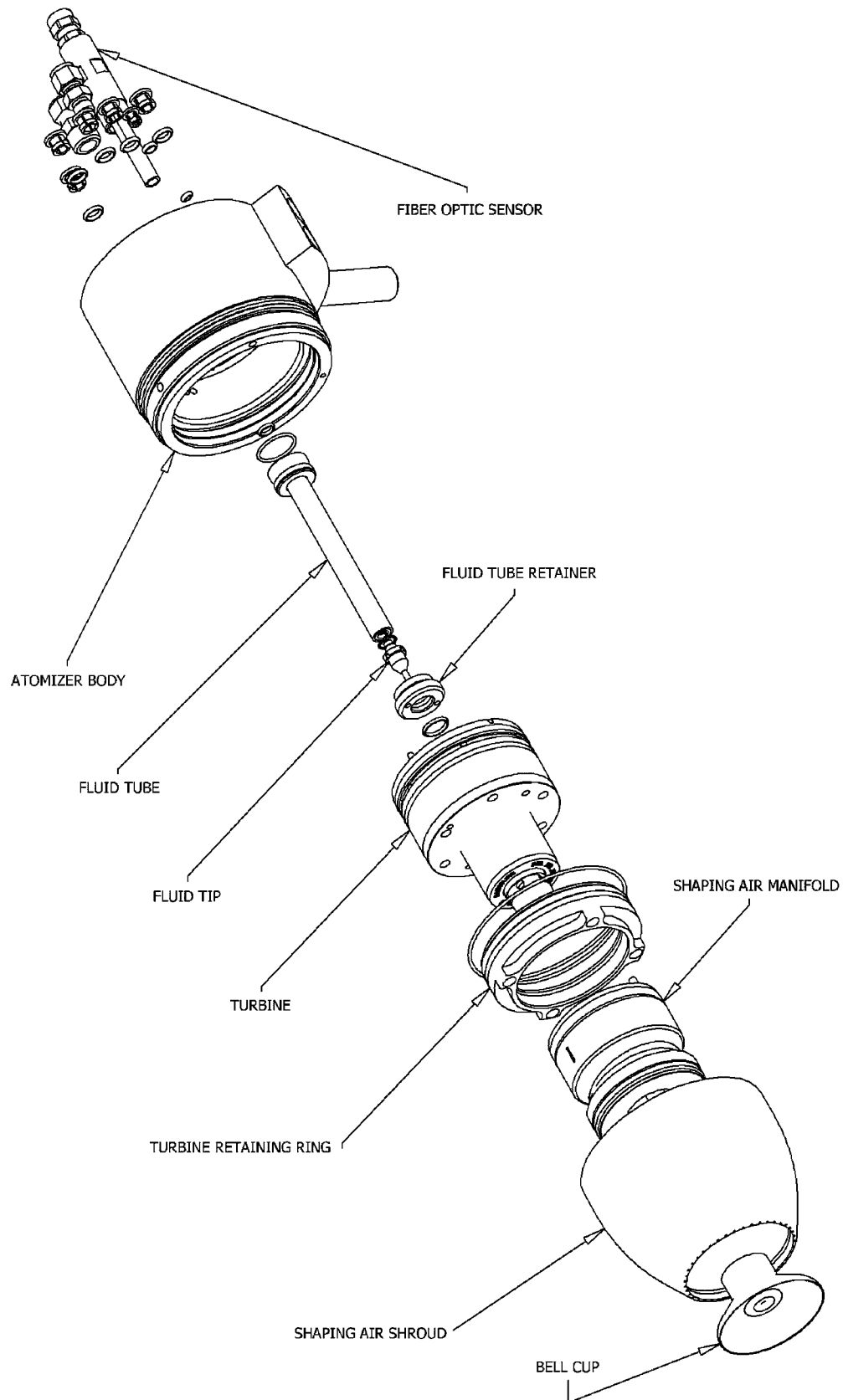

Figure 1: Aerobell 168

OPERATING CHARACTERISTICS AND SPECIFICATIONS		
Weight		
	Atomizer (Post Mount 65mm)	2.7 kg (6 lbs.)
	Atomizer (Robot Mount /Valves/65mm)	4.4 kg (9.7 lbs.)
Voltage		
	Maximum Operating Voltage	90 kV
	Maximum Operating Current	80 uA
Turbine		
	Recommended Turbine Speed	15 to 60 Krpm
	Turbine Type	Impulse - Rear Exhaust
	Speed Readout Pickup	Magnetic or Light Source (2 pulse/rev.)
Paint		
	Flow Rate	50-500 cm ³ /min max. (depending on paint)
	Normal Supply Pressure	6 to 8 bar (90 psi to 120 psi)
	Maximum Pressure	10 bar (150 psi)
	Viscosity	20 to 40 Seconds - Ford Cup # 4
	Viscosity	20 to 45 Seconds - AFNOR Cup # 4
	Paint Resistivity	0.1 MΩ. to ∞*
Air Pressure		
	Microvalve Pilot	4.9 bar (Min.) - 10 bar (Max.) (75-150 psi)
	Bearing Air	5.5 bar (Min.) - 7 bar (Max.) (80 - 100 psi)
	Shaping Air	7 bar Max. (100 psi)
	Brake Air	4 bar Min. - 7 bar Max. (60-100 psi)
Change Time		
	Rotary Atomizer	Less than 5 minutes
	Bell	Less than 5 minutes
Distance		
	Target	204 - 305mm (8-12 inches)
Compressed Air Quality		See Filter Section
Air Consumption		
	Bearing Air	57 - 85 slpm (2-3 scfm)
	Shaping Air 1	75 to 600 NI/min (2.65-21.2 scfm)
	Shaping Air 2	75 to 600 NI/min (2.65-21.2 scfm)
	Turbine	See Charts

* When measured with Ransburg meter 76652

OPERATING CHARACTERISTICS AND SPECIFICATIONS



OPERATING CHARACTERISTICS AND SPECIFICATIONS

**Aerobell 168
Air Consumption vs Speed (Loaded)**

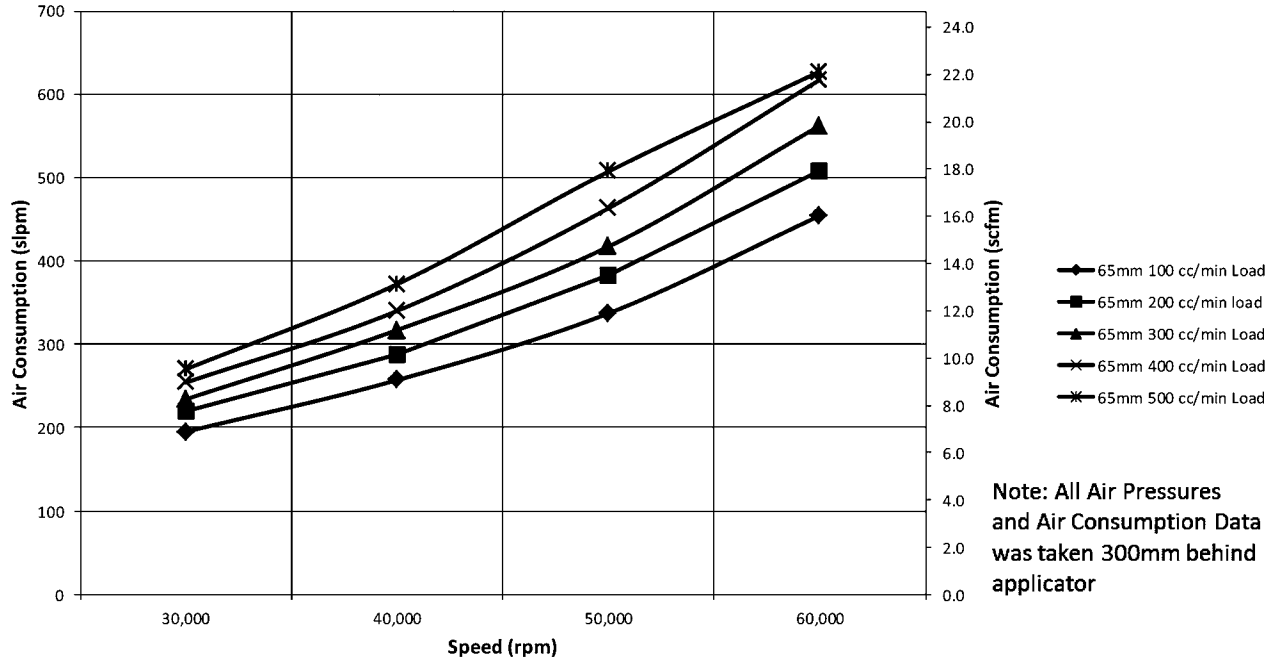

**Aerobell 168
Air Consumption vs Speed (Loaded)**

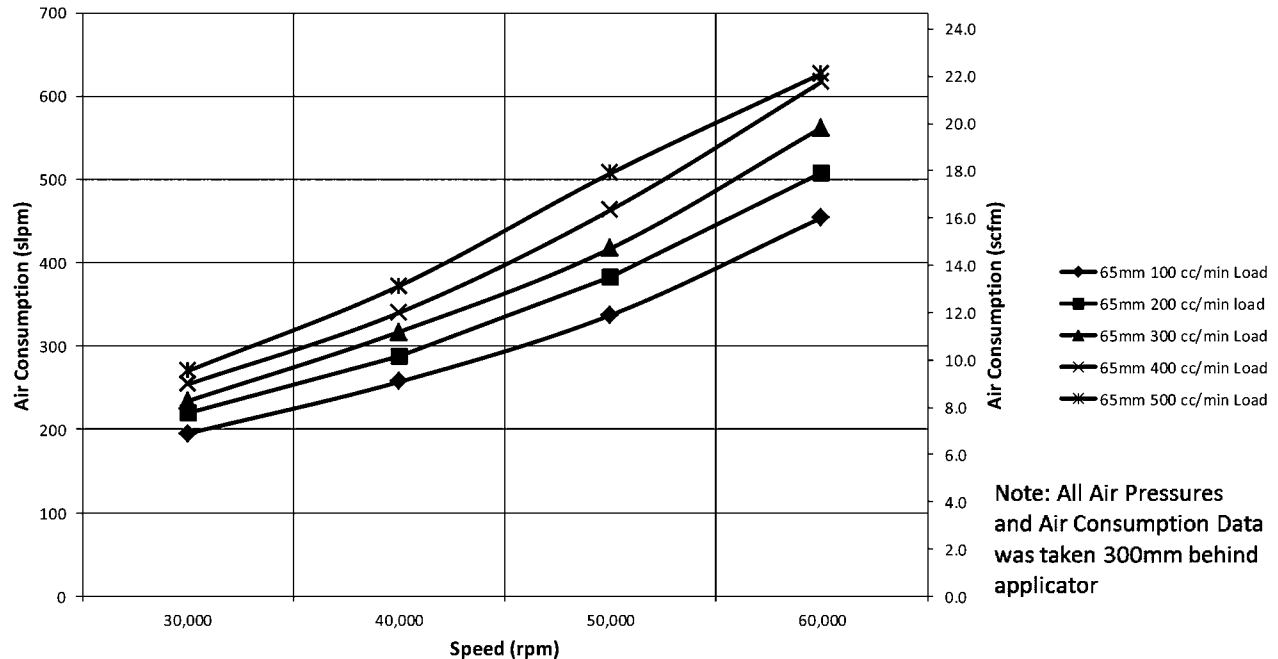

OPERATING CHARACTERISTICS AND SPECIFICATIONS

**Aerobell 168
Air Consumption vs Speed (Loaded)**

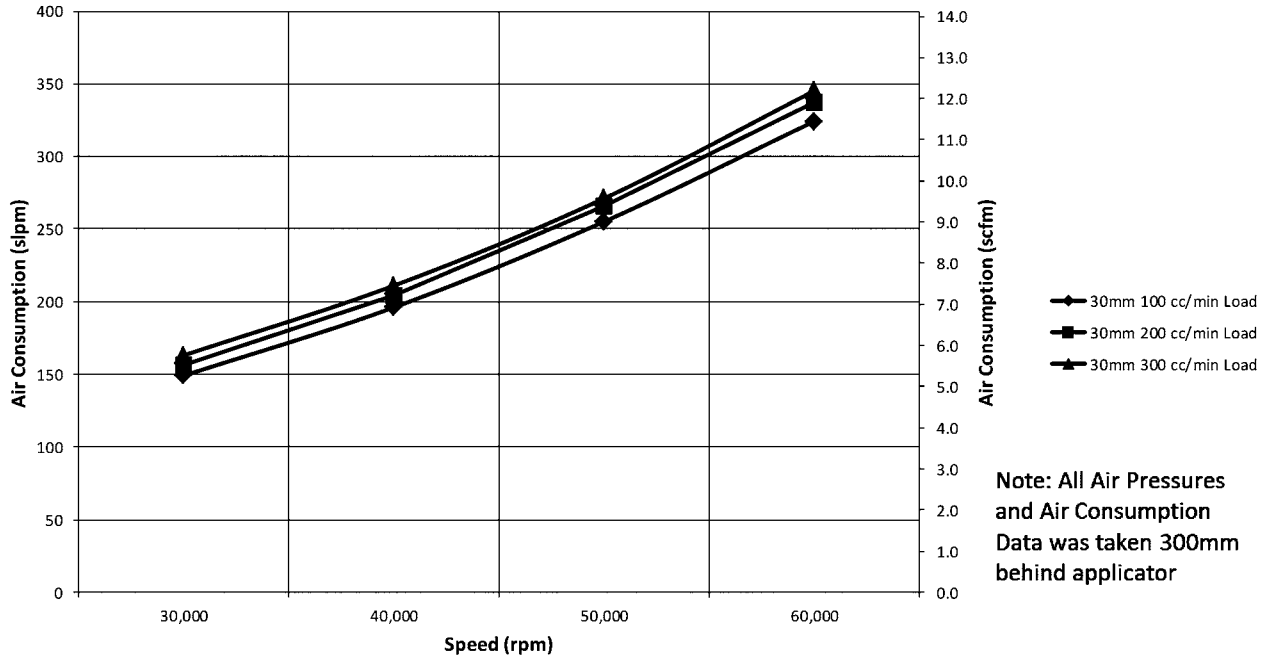

**Aerobell 168
Air Pressure vs Speed (Loaded)**

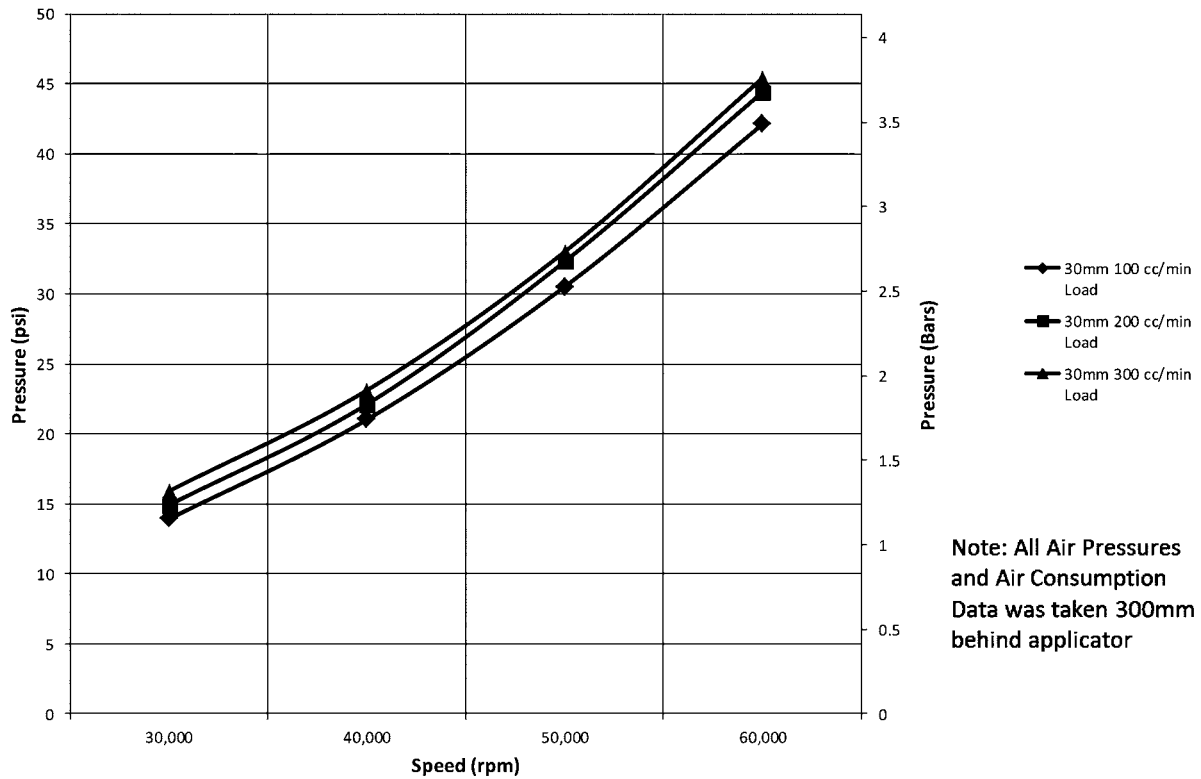

DIMENSIONAL CHARACTERISTICS

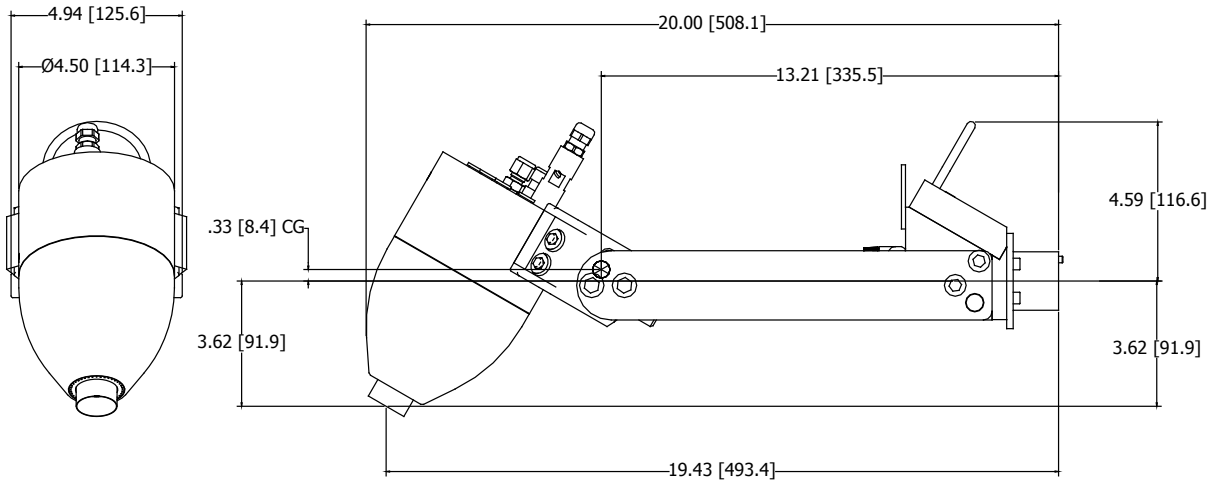

30 MM FANUC ROBOT MOUNT - 60 DEGREES
15 MM FANUC ROBOT MOUNT - 60 DEGREES

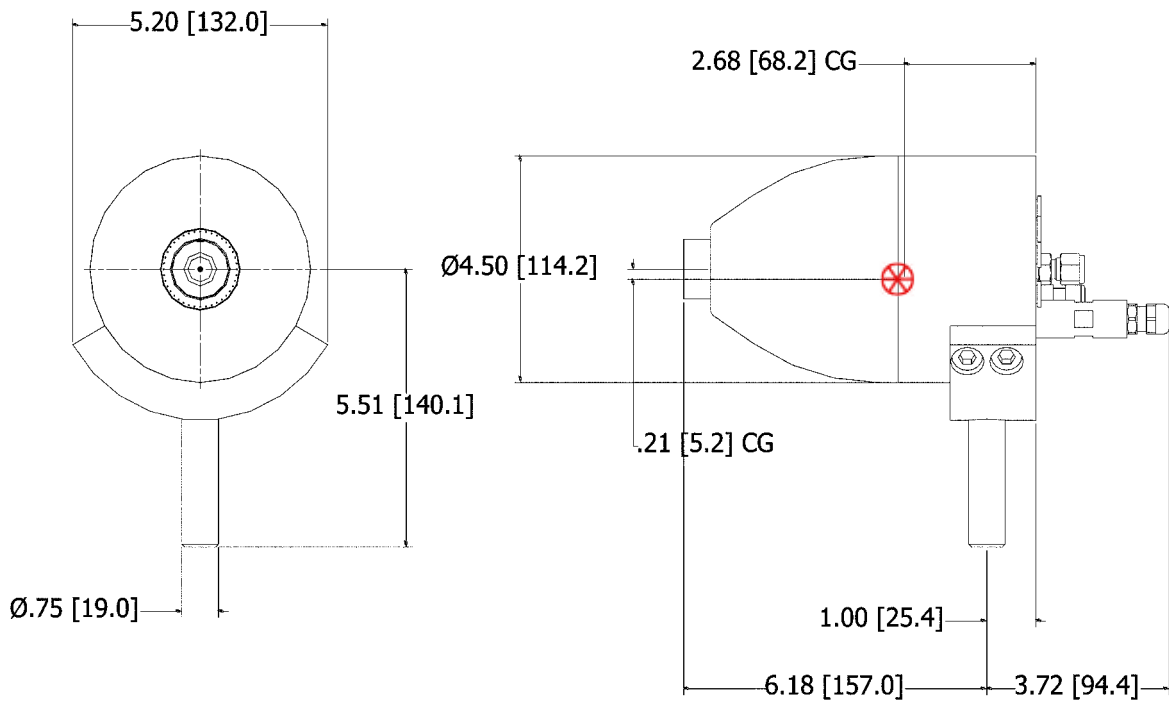

30 MM POST MOUNT
15 MM POST MOUNT

DIMENSIONAL CHARACTERISTICS

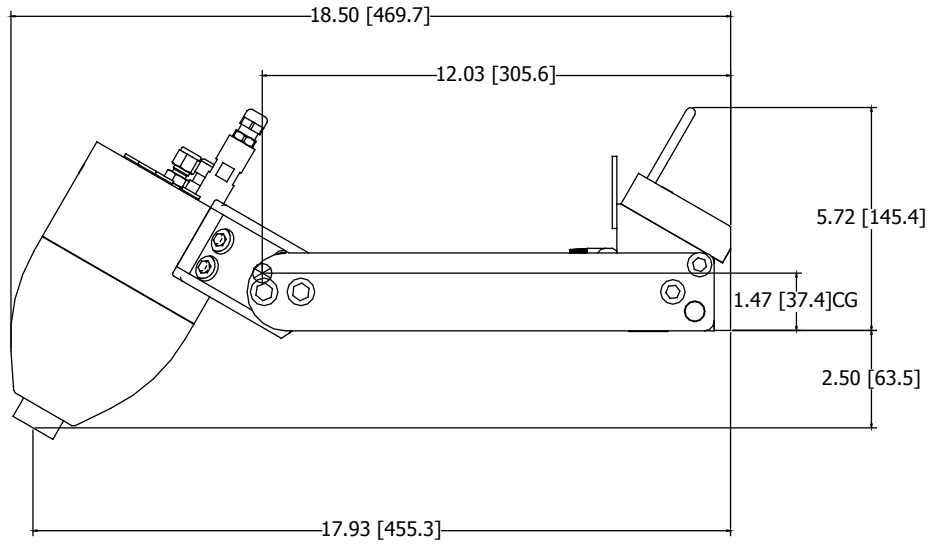
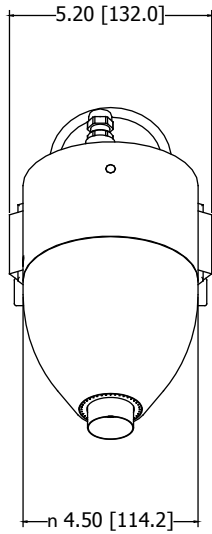

30 MM MACHINE MOUNT - 60 DEGREES
15 MM MACHINE MOUNT - 60 DEGREES

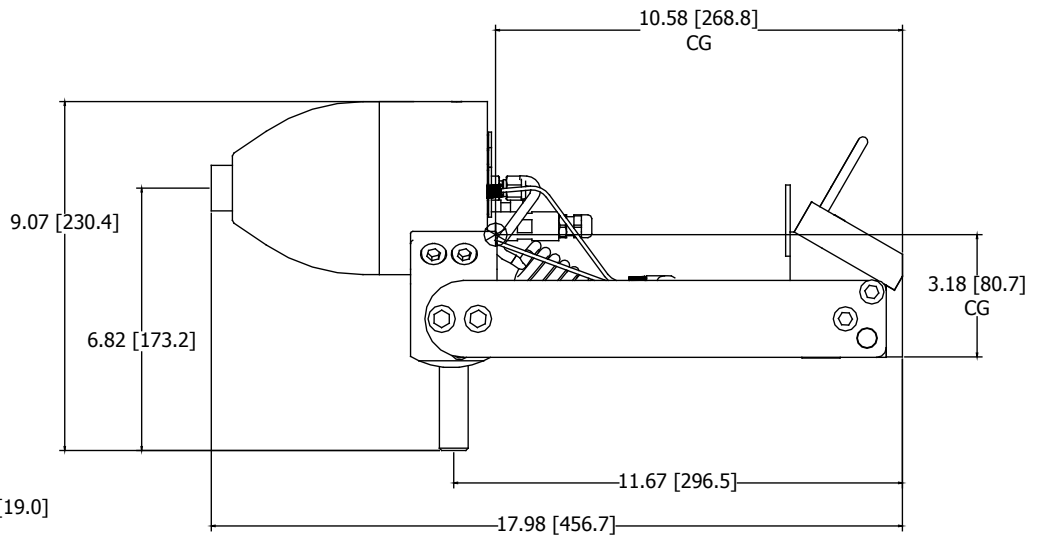
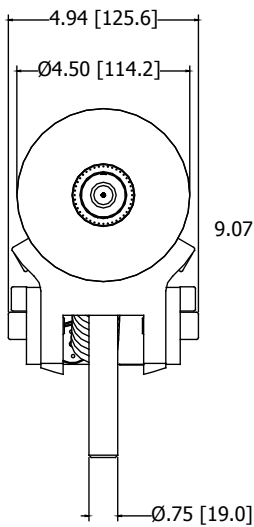

30 MM MACHINE MOUNT - STRAIGHT
15 MM MACHINE MOUNT - STRAIGHT

DIMENSIONAL CHARACTERISTICS

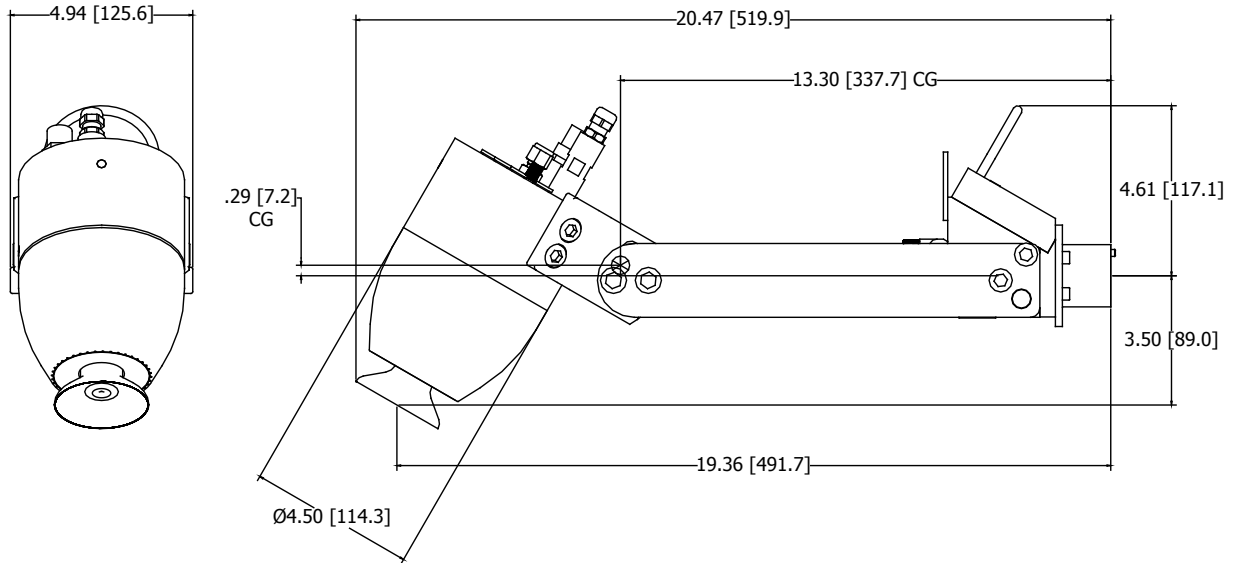

65 MM FANUC ROBOT MOUNT

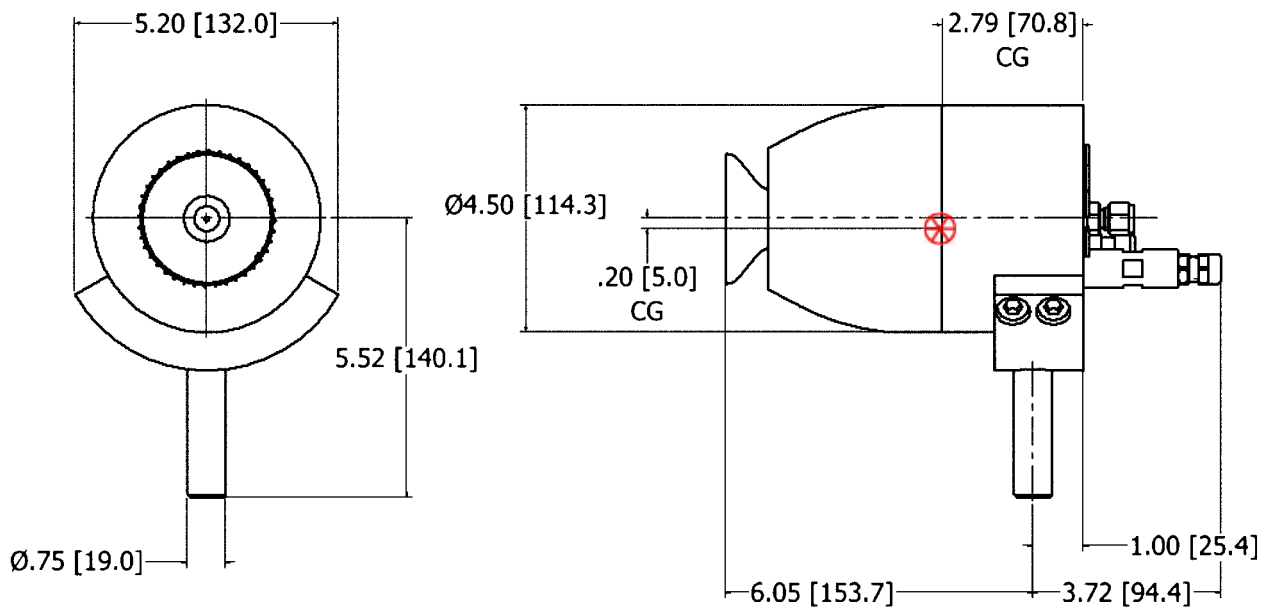

65 MM POST MOUNT

DIMENSIONAL CHARACTERISTICS

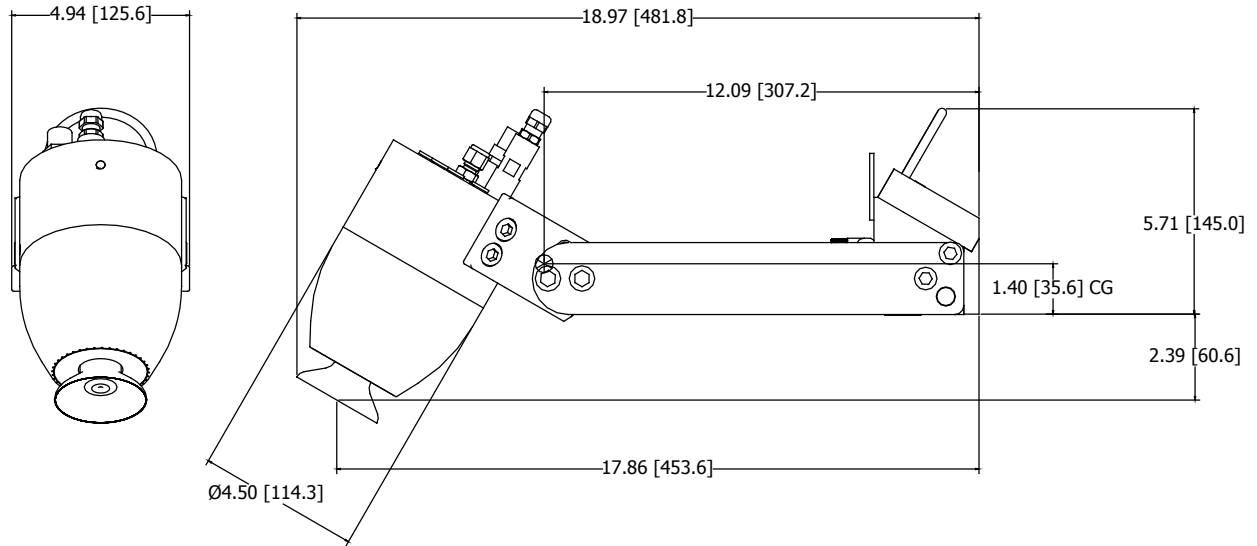

65 MM MACHINE MOUNT - 60 DEGREES

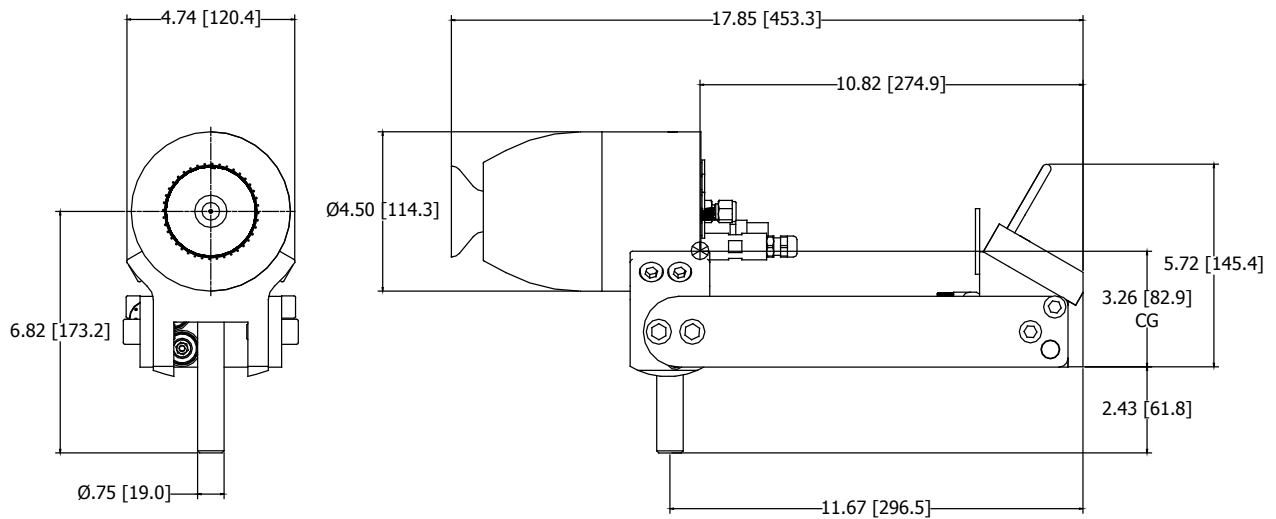

65 MM MACHINE MOUNT - STRAIGHT

IMPORTANT NUMBERS

Record these numbers in a log book for future reference. The last digits of the Atomizer serial number are also the Turbine serial number.

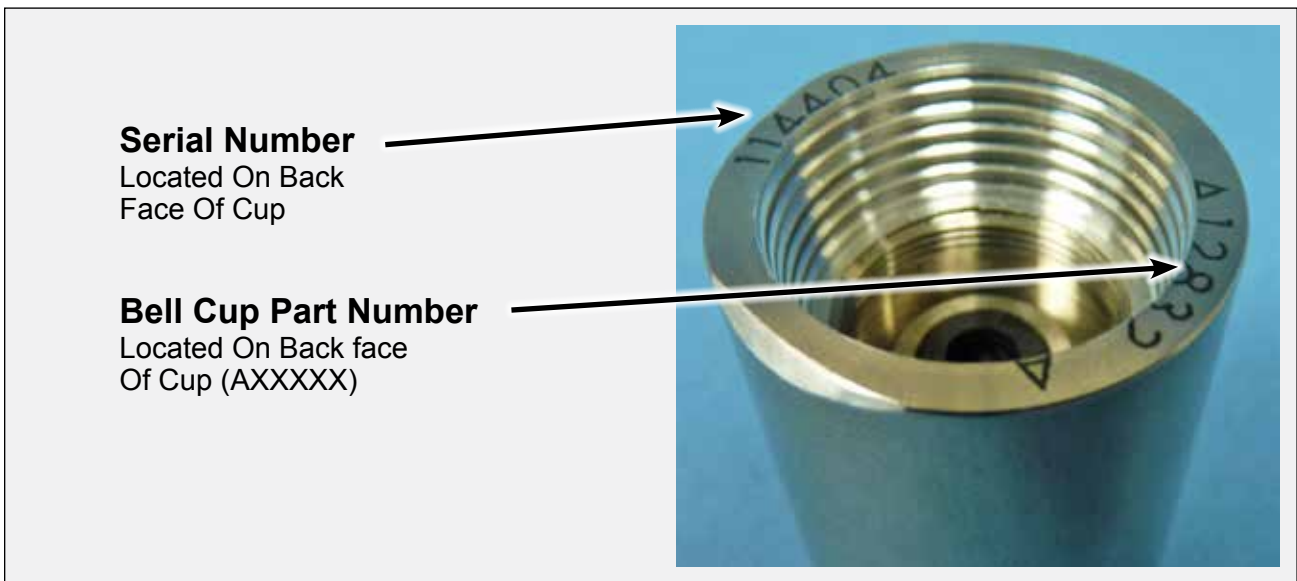
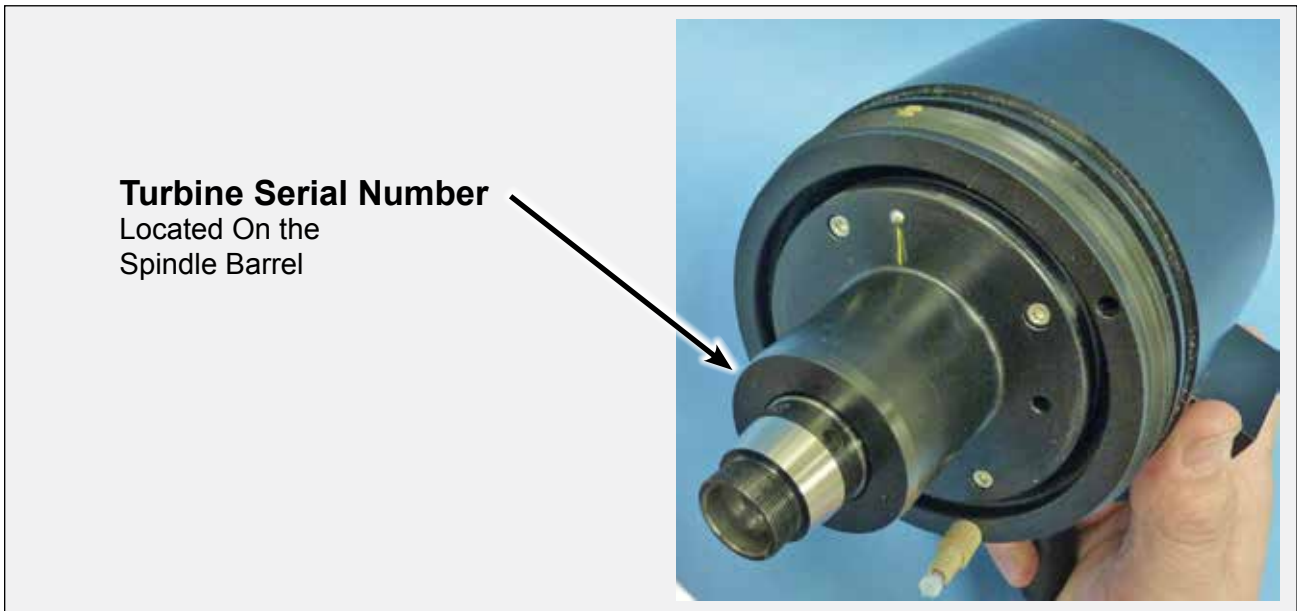

HOSE SPECIFICATIONS

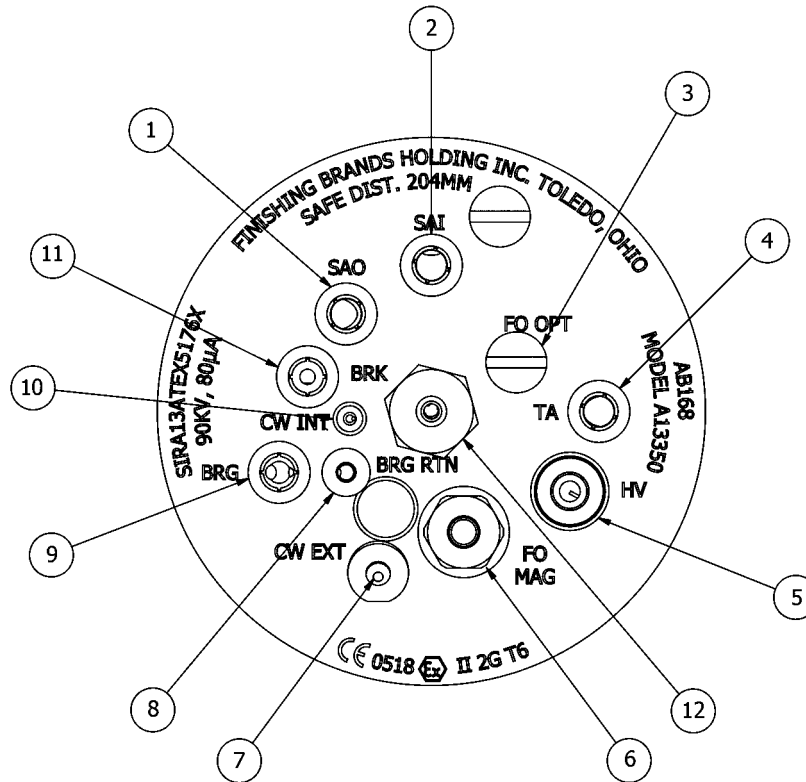

REAR MANIFOLD PORT CONNECTIONS

HOSE SPECIFICATIONS IDENTIFICATION	
Item #.	Description
1	8MM -5/16 O.D. TUBE
2	8MM -5/16 O.D. TUBE
3	FIBER OPTIC CONNECTION (OPTIONAL FOR LIGHT SOURCE REFLECTIVE TYPE) (PROVIDED BY INTEGRATOR)
4	8MM - 5/16 O.D. TUBE
5	HIGH VOLTAGE CABLE CONNECTION
6	FIBER OPTIC CONNECTION (RANSBURG MAGNETIC TYPE)
7	EXTERNAL CUP WASH CONNECTION
8	4MM - 5/32 O.D. TUBE
9	8MM -5/16 O.D. TUBE
10	INTERNAL CUP WASH CONNECTION
11	8MM -5/16 O.D. TUBE
12	1/4" O.D. TUBE PAINT SUPPLY

INSTALLATION

GENERAL INFORMATION

This information is intended ONLY to indicate the general installation parameters of this product and, where applicable, its working relationship to other Ransburg system components in typical use.

Each installation is unique and should be directed by an authorized Ransburg representative or conducted using the Ransburg installation drawings provided for your particular installation.

WARNING

- Risk of arcing/fire hazard. The Aerobell 168 must be located a safe distance from the object to be sprayed, as well as all other grounded objects. The safe distance is 204mm (8”).
- This must be installed with fire protection and fire detection per EN 50 176.
- Power Unit must be interlocked with conveyor and booth fan.

CAUTION

- The Aerobell 168 shipping container includes the basic atomizer assembly with bell and manifold. Tool options for bell cup removal and dis-assembly of other components can be purchased with the atomizers or ordered separately.
- Mount the Aerobell 168 securely to a stationary or reciprocating fixture with the 3/4-inch (19MM) diameter stud provided.

AIR FILTER INSTALLATION

The following guidelines must be observed when installing air filters for the Aerobell 168 system (see “Air Filtration Requirements Chart” for additional information).

1. Use only recommended pre-filters and bearing air filters as shown in “Recommended Air Filtration Requirements” in this section. Additional system air filtration (i.e., refrigerated air dryer) may also be used if desired.
2. Use one bearing air filter per Aerobell.
3. Mount the bearing air filter as close as possible to the Aerobell 168 (do not mount further than 30 feet (9M) away).
4. Where possible, the pre-filter(s) and bearing air filter(s) should be mounted where they can be easily seen, so the user will see when maintenance is required.
5. Standard black iron or galvanized piping may be used prior to the HAF-503 or HAF-508 pre-filters only. All piping after the pre-filter should be brass, stainless steel, aluminum, or hose (poly, nylon, nyloner, etc.).
6. **Do not** use PTFE tape, pipe dope, or other thread sealant downstream of the bearing air filter. Loose flakes of PTFE tape or other sealant can break loose and plug the very fine air holes in the turbine bearings.
7. Use clear see-through air tubing between the bearing air filter and bearing air fitting to clearly indicate to the user if oil or moisture contamination is getting past the filter.
8. If air heaters are used in the system (to minimize the effect of excessively humid conditions), and the heated air will exceed 120°F, the heaters must be located after all filters to prevent damage to the filter media.

HOSE SPECIFICATIONS	
Function	Hose Characteristic
Paint Supply @ Applicator	1/4" O.D. Tube Fitting
Paint Supply @ Valve Manifold	5mm I.D. x 8mm O.D. PFA (.197" I.D. x 5/16" O.D.) Option
Paint Supply @ Valve Manifold	6mm I.D. x 8mm O.D. PFA (.236" I.D. x 5/16" O.D.) Option
Turbine Supply @ Applicator	6mm I.D. x 8mm O.D. Nylon (.236" I.D. x 5/16" O.D.)
Turbine Braking Air Supply @ Applicator	6mm I.D. x 8mm O.D. Nylon (.236" I.D. x 5/16" O.D.)
Bearing Air Supply @ Applicator	6mm I.D. x 8mm O.D. Nylon (.236" I.D. x 5/16" O.D.)
Bearing Air Return @ Applicator	2.7mm I.D. x .4mm O.D. Nylon (.107" I.D. x 5/32" O.D.)
Shaping Air 1 @ Applicator	6mm I.D. x 8mm O.D. Nylon (.236" I.D. x 5/16" O.D.)
Sharping Air 2 @ Applicator	6mm I.D. x 8mm O.D. Nylon (.236" I.D. x 5/16" O.D.)
Interior and Bell Cup Exterior Rinsing Air/Solvent	1/16" I.D. x 3/32" O.D. PFA
Dump @ Valve Manifold	5mm I.D. x 8mm O.D. PFA (.197" I.D. x 5/16" O.D.) Option
Dump @ Valve Manifold	6mm I.D. x 8mm O.D. PFA (.236" I.D. x 5/16" O.D.) Option
Pilot for all Microvalves	2.7mm I.D. x .4mm I.D. Nylon (.107" I.D. x 5/32" O.D.)
Interior and Bell Cup Exterior Rinsing Solvent Supply @ Valve Manifold	5mm I.D. x 8mm O.D. PFA (.197" I.D. x 5/16" O.D.)
Interior and Bell Cup Exterior Rinsing Air Supply @ Valve Manifold	5mm I.D. x 8mm O.D. PFA (.197" I.D. x 5/16" O.D.)

⚠ WARNING

- Arcing/fire hazard exist if ungrounded metal connections (air or fluid) are used in the spray area. Use plastic non-conductive connections, or ensure metal connections are at ground potential.

PFA* hoses must never be replaced with Nylon hoses. Only Polyamide Nylon hoses can be used for air connections. Polyurethane hoses are prohibited.

* PFA = Ultra Pure Polytetrafluoroethylene

⚠ CAUTION

- Any user supplied air hoses must be rated at a minimum working pressure of 100 psig (7 bar)

⚠ CAUTION

- Any user supplied fluid hoses must be rated at a minimum working pressure of 150 psig (10 bar)

AIR FILTRATION REQUIREMENTS		
Ransburg Filter Model No.	Description / Specifications	Replacement Element Part No.
HAF-503	Pre-filter, removes coarse amounts of oil, moisture and dirt. Used upstream of HAF-508 pre-filter (used in systems with poor air quality).	HAF-15 Element One
HAF-508	Pre-filter, coalescing type, 136 SCFM, 98.5% efficiency particulate removal .3 to .6 micron, max. aerosol passed 1.0 micron, max. solid passed .4 micron (dependent upon SCFM requirement per applicator, one HAF-508 can be used with up to three Aerobell 168 assemblies).	HAF-38 Elements, Carton of 4
RPM-418	Bearing air filter, coalescing type, 19 SCFM, 99.995% efficiency particulate removal .3 to .6 micron, max. Aerobell 168 passed .6 micron max. solid passed .2 micron (one per Aerobell 168)	RPM-33 Elements, Carton of 8

⚠ CAUTION

- Air must be properly filtered to ensure extended turbine life and to prevent contamination of the paint finish. Air which is not adequately filtered will foul the turbine air bearings and cause turbine failure. The correct type filters must be used in an Aerobell 168 system. The filter elements must be replaced regular schedule to assure clean air.
- It is the user's responsibility to ensure clean air at all times. Turbine failure resulting from contaminated air will not be covered under warranty. If other filters are incorporated in the system, the filters to be used must have filtering capacities equal or better than those shown in "Air Filtration Requirements Charts."
- The user must ensure the bearing air supply is not inadvertently turned off while the Aerobell 168 air motor is turning. This will cause air bearing failure.

NOTE

- Each applicator must have its own filter for bearing air. Recommended: RPM-418 or equivalent.

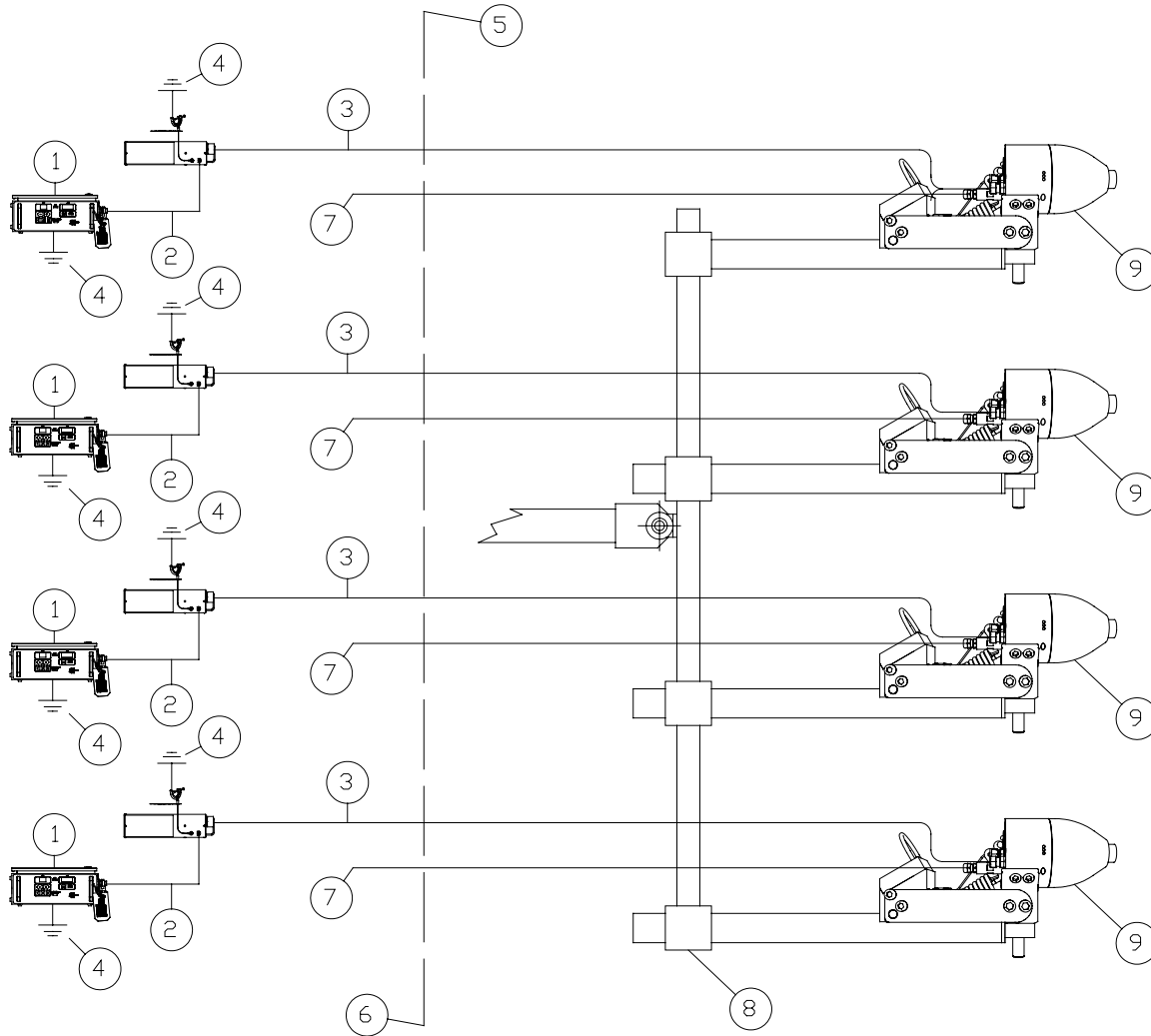

Typical Multiple Applicator Configuration

TYPICAL MULTIPLE APPLICATOR CONFIGURATION	
Item #.	Description
1	80100-51X OR 80120-51X (9060) WITH 80104-01 EXTERNAL CASCADE
2	79338-15 LOW VOLTAGE CABLE
3	A13386-XX OR A13348-XX HIGH VOLTAGE CABLE
4	TRUE EARTH GROUND
5	BOOTH WALL - HAZARDOUS AREA SIDE
6	BOOTH WALL - SAFE AREA SIDE
7	OPTIONAL FIBER OPTIC
8	VERTICAL GUN BAR OR RECIPROCATOR OR STATIONARY STAND
9	AB 168 APPLICATOR

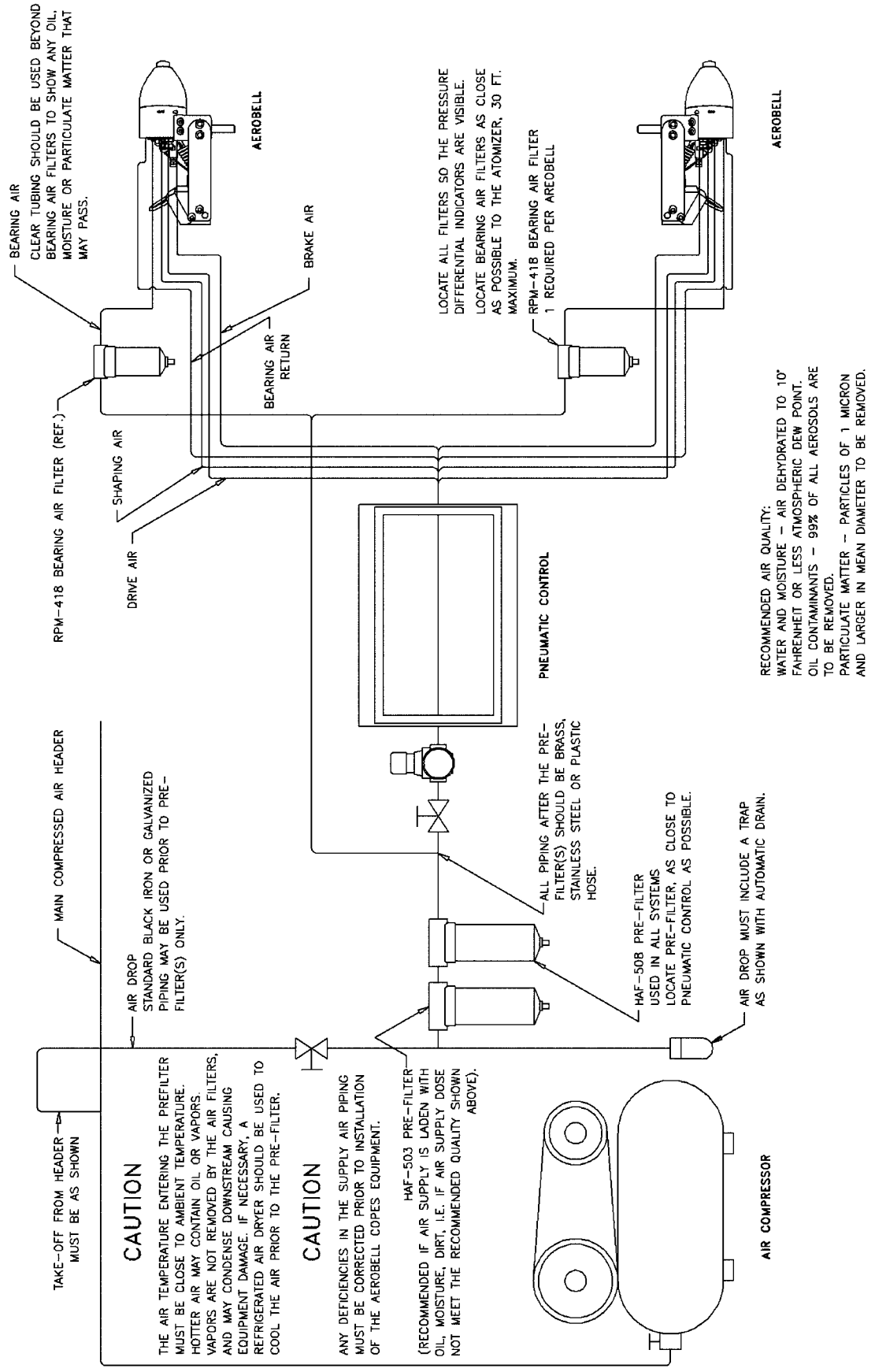

AIR HEATER REQUIREMENTS

Turbine drive air expands as it moves through the turbine wheel cavity and as it exits the turbine from the exhaust port. This expansion will cause cooling of the exhaust air and the surfaces it contacts. This same expansion cooling can occur across the shaping air exit ports. This cooling effect can cause surface temperatures to fall below the dew point of the booth, which will result in condensation on the interior and exterior of the atomizer, machine, and its components. It is even possible that the temperature of the supply air may be below the booth dew point, even without additional expansion cooling.

Condensation is especially probable in waterborne applications when booth temperature and relative humidity levels are typically maintained very high. This condensation will allow sufficient conductivity of the surfaces such that they act as an erratic ground source potential. This can cause damage to the equipment.

It is therefore, a requirement that turbine exhaust air temperature be maintained above the booth dew point to prevent condensation from forming on atomizer surfaces. Doing so will eliminate moisture as a potential defect in painted surfaces as well as extending equipment life. Thus, it is recommended that air heaters be installed into the atomizer air supply lines, i.e. Turbine air. The air heaters must be of sufficient capacity capable of raising the incoming air temperature at least 40°F (4.4°C) at a flow rate of 60 SCFM per applicator.

The actual air heater process setting depends on applicator fluid flow rate load, booth conditions, turbine airflow settings, and incoming air temperature. The heater should be set as low as possible, sufficient to maintain the applicator surface temperatures above the dew point in the booth.

Example: With the incoming air temperature at 72°F (22.2°C), an Aerobell 168 with 65mm bell cup rotating unloaded at 60 krpm has a turbine outlet temperature drop of approximately 28°F (-2.2°C) (@ 40 krpm unloaded, DT ~ 14°F (-.10°C).

Referring to the ASHRAE Psychometric chart, the saturation temperature range (dew point) of a spray booth maintained at 70-75°F / 65-70% RH is 62-68°F (21.1-23.9°C / 65-70° RH is 16.7-20°C). Thus it is almost certain that the surface temperatures of the applicator will fall below the dew point of the booth, and an air heater will be needed in this case.

To prevent condensation, Ransburg air heater assembly should be assembled after the air filters. (Reference the current "Air Heater Assembly" service manual for further information.)

NOTE

- Failure to use an air heater may cause damage to equipment or ruin the finished component being processed.

⚠ WARNING

- Arcing/fire hazard exist if ungrounded metal connections (air or fluid) are used in the spray area. Use plastic non-conductive connections, or ensure metal connections are at ground potential.

⚠ CAUTION

- Do not use PTFE tape or pipe dope on any air beyond the final air filter for BEARING AIR. The tape or dope may break free and cause plugging of the turbine air bearings, and result in turbine failure. See pages 23 & 24 for tubing connections and sizes.)

Bearing Air

Use tubing (clear, see-through, nylon, natural) to connect a properly filtered air source to the bearing air fitting on the manifold. It is recommended to use tubing (clear, see-through) for bearing air so that any contamination that gets past the final bearing air filter will be apparent. Also refer to the previous “Caution”.

Under the “Operation” section which follows, there is a “Caution” regarding bearing damage if the turbine is run while bearing air is off. Since the turbine must not be operated without first turning on bearing air, it is required to provide some means of assuring the presence of bearing air before turning the turbine “On.” One method is by interlocking the turbine drive air to the bearing air (i.e., with an air piloted valve).

⚠ CAUTION

- Provisions should also be made to assure bearing air remains on during the coast down period when turbine air is turned off. See “Specifications” in the “Introduction” section of this manual

Brake Air

NOTE

- Brake air is used to slow the turbine when changing speed. It is recommended that the brake air turbine drive air be interlocked.

Turbine Air

Turbine drive air must be interlocked with paint flow. Damage to spindle will occur if paint is triggered without the bell cup spinning. It is recommended that the bell cup is spinning at least 10,000 rpm before any fluid is turned on.

FLUID CONNECTIONS

See pages 24 & 26 for connections. See the following “Note”.

NOTE

- If the coating material used is heated, check the maximum rated temperature for the fluid tubing used. Polyethylene tubing (H-2338 and H-2339) is rated for a maximum of 80°F (27°C). Nylon tubing (H-2340 and H-2341) is rated for 200°F (95°C) maximum.

⚠ CAUTION

- Any user supplied air hoses must be rated at a minimum working pressure of 100 psig (7 bar)

⚠ CAUTION

- Any user supplied fluid hoses must be rated at a minimum working pressure of 150 psig (10 bar)

HIGH VOLTAGE

See “Typical Multiple Application Configurations” in the “Introduction” section.

INTERLOCKS

The following system interlocks are recommended to prevent equipment damage:

1. Bearing air should remain on at all times and should be shut off only by turning off the main air to the pneumatic control cabinet.
2. It should not be possible for the coating material to be sprayed unless the turbine is spinning.
3. Two (2) interconnected bearing air ports are provided, one for supply air and the other to be used as a return signal for measuring bearing air pressure at the atomizer. If bearing air falls below 80 psi (552 kPa) at the atomizer, the turbine air should be automatically interlocked to shut off.
4. High voltage must be interlocked with the solvent valve pilot signal to prevent solvent flow while high voltage is energized.
5. Turbine air and brake air must be interlocked to prevent both from being used simultaneously.
6. Any other interlocks required by local code, national code, or international code.
7. High voltage must be interlocked with the booth entry door.
8. High voltage must be interlocked through the power unit with conveyor and booth fan air. Reference manual CP-13-02 for procedures.



WARNING

- When the turbine air is turned off, the turbine will continue to operate or “coast down” for about two minutes. Provisions should be made to assure that the operator waits at least three minutes, after shutting off the turbine air and before shutting off the main air supply.
- Under normal operation, the high voltage and/or coating material must never be turned on unless the bell cup is mounted on the motor shaft and the turbine is rotating.
- Pneumatic input to the turbine air inlet must be controlled to prevent the turbine from exceeding the maximum rated speed of 60,000 rpm. (See “Specifications” in the “Introduction” section.)
- High voltage must never be turned on while cleaning solvent is being sprayed either through the applicator supply or the cup wash line. High voltage and solvent trigger must be interlocked.
- Never spray solvent with high voltage on.



CAUTION

- The bell cup must be removed when making flow checks. If the paint is turned on when the bell is mounted and the turbine shaft is not rotating, paint will enter the shaft and possibly damage the air bearing. Material flow checks (flow rate verification) must be made with the bell cup and the turbine not rotating. Normally pneumatic interlocks will not allow the paint to trigger on when the turbine air is off. These interlocks may need to be bypassed with proper safety procedures as required.
- Bell cup must be rotating at least 10,000 rpm when fluid is triggered. Turning on fluid without the bell cup spinning may flood the turbine and cause damage to components.

HIGH VOLTAGE CABLE ASSEMBLIES

General Instructions

1. When routing cable, ensure that no chaffing, binding, or pulling on the cable will occur. Maintain at least a 4-inch (100mm) bend radius. When possible, sleeve cable with the appropriate sized tubing for external cable protection. Torsion stress should be minimized.

2. Considerations should be taken when routing cables next to other cabling and fluid tubing. Be cognizant of the placement of such cable near control wires and fluid lines. Follow NEC or EN standard wiring standards where applicable. Separation of AC, control wiring, and fluid tubing is advisable.

3. To ensure that all cable connections are clean and free of foreign materials, wipe with Naphtha. This also applies to the cascade, splitter, and applicator connectors.

 CAUTION
<p>➤ Do not use any di-electric grease or oil on any of the cable connections or on the cables themselves. Damage to cables will occur.</p>

4. Ensure that no conductive sponges are used in any connector!

5. A13386-XX or A13348-XX cables are not to be modified in the field. To do so will void any and all warranties that may exist.

HIGH VOLTAGE CABLE CONFIGURATIONS

There are two (2) high voltage cable assemblies available:

A13386-XX is a shielded cable and is the most flexible. It is available in several lengths per the "Accessories" chart in the "Parts Identification" section.

A13348-XX is a resin core conductor cable with a polyethylene jacket and an exterior Nylon sleeve. It comes pre-assembled with banana jacks at each end.

AEROBELL 168 HIGH VOLTAGE CONNECT AT ATOMIZER END

Installation of A13348-XX Cable

Insert resistor (Shipped separately with Applicator) A13382-00 into the applicator end of the cable.

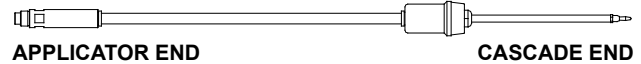

Make sure the contact spring is outward as shown below

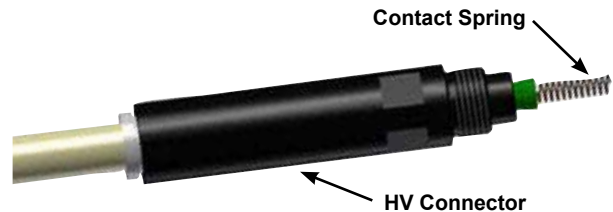

Insert the high voltage connector on the cable end into the applicator part marked with "HV". Tighten the connector in place.

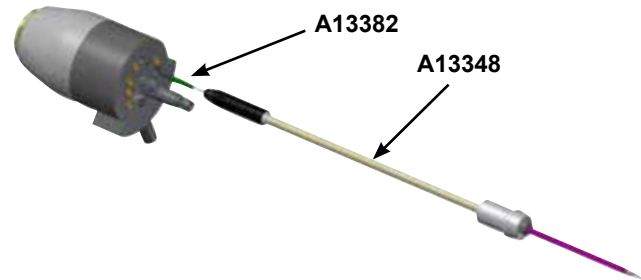

Installation of A13386-XX Cable

Insert resistor (Shipped seperately with Applicator) A13382 into the part of the applicator marked HV.



The spring should be inserted first into the part.

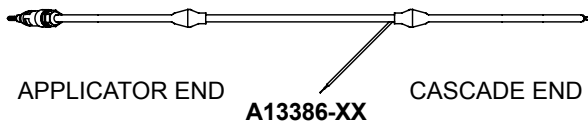

Using the applicator end of the cable loosen the strain relief and remove the cable from the High Voltage Connector. Thread and tighten the High Voltage Connector into the Port marked "HV" on the back of the applicator. Insert the cable through the strain relief until contact is made with the resistor. Tighten the strain relief to secure the cable.

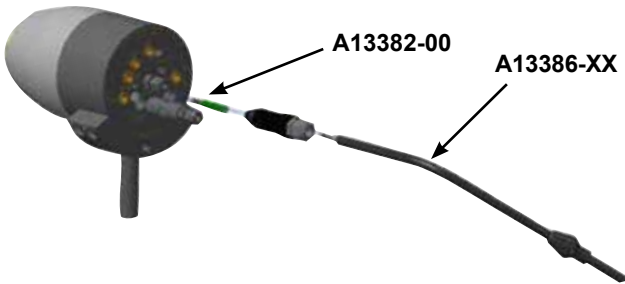

**AEROBELL 168
CASCADE CONNECTION**

Insert the cable end of the A13386-XX cable into the external cascade as shown.

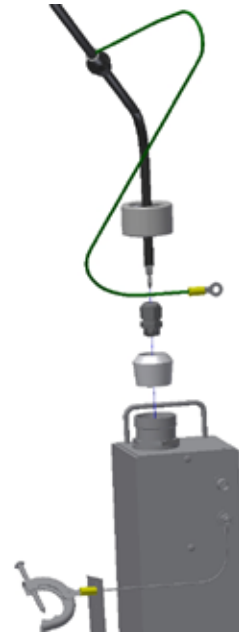

Insert the cascade of the A13348-XX cable end into the external cascade as shown.



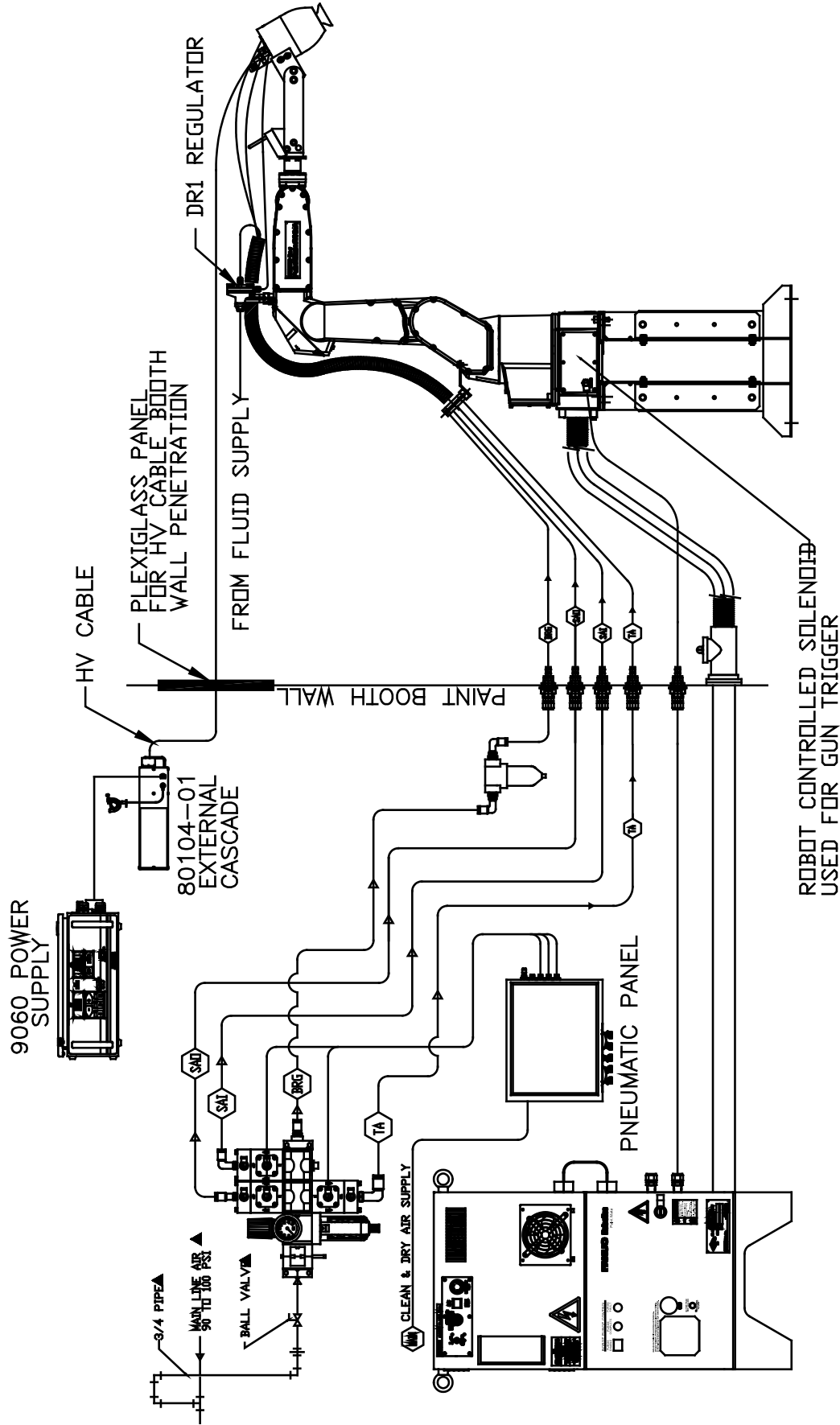

65MM ROBOT MOUNTED WITH 9060 POWER SUPPLY FANUC PAINT MATE

OPERATION

! WARNING

- Operators must be fully trained in safe operation of electrostatic equipment. Operators must read all instructions and safety precautions prior to using this equipment (see NFPA-33, EN 50 176)
- Electrical discharge on a high electrical capacitance fluid/paint system can cause fire or explosion with some materials. If arcing occurs when a specific material is used, turn the system OFF and verify that the fluid is non-flammable. In these conditions, the system is capable of releasing sufficient electrical and thermal energy to cause ignition of specific hazardous materials in the air.

! CAUTION

- When turning the turbine on, bearing air must be present. Likewise, bearing air must remain on when the turbine air is turned off until the turbine stops spinning. Never turn off bearing air to cause the turbine to stop spinning. Brake air can be used to slow the turbine (see “Brake Air” in this section. Wait for the turbine to stop spinning before turning bearing air off.

As with any spray finishing system, operation of the Aerobell 168 involves properly setting the operating parameters to obtain the best finish quality for the coating material being sprayed while maintaining correct operation and reliability of the equipment used. Adjustments to operating parameters, which cover spraying, cleaning, and ON/OFF control, include the following:

- Coating Materials
- Fluid Flow Rate Control
- Fluid Valve / Trigger Control
- Turbine Speed
- Shaping Air (pattern control)
- Electrostatic Voltage
- Target Distance

TURBINE SPEED

The speed of the turbine is determined by the air inlet pressure. See “Turbine Air Pressure, RPM, SCFM” in the “Installation” section for more information. The desired speed will depend upon the type of coating material and various application requirements.

! CAUTION

- Excessive speed will cause air turbine damage. Do not exceed the maximum rated speed of 60,000 rpm.

BEARING AIR

CAUTION

- Air bearing air must be on whenever the turbine is operated. If not, severe bearing damage will occur. It is recommended to leave bearing air on at all times. During maintenance or disassembly, turbine air must be off for a least 3 minutes before shutting off air or main line air.
- Bearing damage (and subsequent turbine failure) caused by running the turbine without bearing air will not be covered under Ransburg warranty.
- When turning the turbine on, bearing air must be present. Likewise, bearing air must remain on when the turbine air is turned off until the turbine stops spinning. Never turn off bearing air to cause the turbine to stop spinning. Brake air can be used to slow the turbine (see “Brake Air” in this section). Wait for the turbine to stop spinning before turning bearing air off.
- Operating the turbine with bearing air pressure below 80 psi (measured at turbine inlet) may cause bearing damage.
- The nominal bearing air pressure is 90 psi (6 bar) +/- 10 psi (.7 bar), 80 psi (5.5 bar) minimum, 100 psi (7 bar) maximum. Under no circumstances should the turbine be operated with less than 80 psi bearing air pressure.

BRAKE AIR

Brake air is used to slow the turbine speed. It is advantageous for short color change cycle times, and may be used for stopping the turbine. Use of the brake involves (1) turning off turbine drive air, and then (2) turning the brake air on for a short duration.

Brake air should be interlocked so that it is impossible for air to be applied to the braking system while the turbine air is on.

WARNING

- Electrical discharge of a high electrical capacitance fluid/paint system can cause fire or explosion with some materials. If arcing occurs when a specific coating material is used, turn the system off and verify that the fluid is non-flammable. In these conditions, the system is capable of releasing sufficient electrical and thermal energy to cause ignition of specific hazardous materials in the air.

ELECTROSTATIC VOLTAGE

Depending upon the power supply model used, the maximum output voltage of the power supply can vary. The actual voltage setting will depend upon various coating application requirements. The level of voltage applied to the Aerobell 168 plays an important role with regard to pattern size, efficiency (wrap), penetration into cavity areas, and target distance.

SHAPING AIRS

Shaping air is used to shape the spray pattern. The lower the pressure, the wider the pattern, and conversely, higher pressures result in narrower patterns. Shaping air does not help atomize the material, but does assist in the penetration of atomized particles into cavity areas. Shaping air should be kept at a minimum consistent with coating requirements. Excessive shaping air will cause some atomized particles to blow by the target not allowing full “wrap,” or paint particles to bounce back onto the atomizer.

Note: When Mono Flex shape air configuration is used, one of the inputs on the atomizer body will be required to be plugged. Either input can be used for Mono Flex (SAI or SAO).

Dual Flex Shaping Air Configuration

Both inputs are required. Pattern adjustment:

Increasing the inner air will make the pattern smaller. Increasing the outer air will make the pattern larger.

FLUID FLOW RATE CONTROL

Externally mounted fluid regulators or gear pumps are typically used to control fluid flow.

The atomizer assembly is equipped with valves which are pneumatically operated to direct the flow of paint to either the feed tube or dump line

FLUID TIP STREAM AND TIP STYLE USE

As the picture on the right shows, the fluid stream should be straight and steady. It is best to start out with the smallest tip to achieve the desired fluid flow rate. Either the Straight or the Industrial tip can be used with any 30mm or 65mm bell cup.

Determining which type of tip style to use is dependent on the several factors, such as viscosity, flow rate, type of equipment supplying the paint. As couple of suggestions follow:

Straight Fluid tip:

With positive shutoff devices like a microvalve with all ranges of fluid flow rates and viscosities.

Industrial Fluid tip:

With pilot operated fluid regulators with high viscosities and low fluid flow rates.

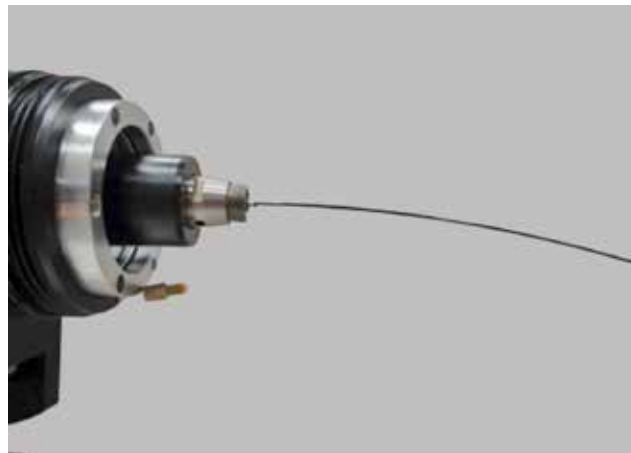

Preferred



Avoid

Fluid Flow Rate Check

In the test mode , the flow rate can be measured by removing the bell cup from the atomizer, turning the fluid flow on, and capturing the material in a graduated beaker or measuring cup for a fixed period of time (shaping air, high voltage, and turbine air must be off).

! WARNING

- Danger of shock and/or personal injury can occur. Proper ground procedures must be followed. Personnel must never work around the turbine when the turbine is spinning or when high voltage is turned on.

TARGET DISTANCE

The distance from the Aerobell 168 atomizer to target affects the spray application. For instance, closer distances give a smaller spray pattern and greater efficiency. Increasing the distance will give a larger pattern and possibly reduce efficiency. If the distance is too great, material may “wrap back” on the Aerobell 168. The safe distance for the Aerobell 168 is 204mm or 8”. All ground objects must be prevented from entering this area.

! WARNING

- The safe distance of use for type AB168 Electrostatic Bell is **204mm** from the bell cup to earthed parts. The end user must ensure this distance, as a minimum is maintained and that grounded objects are prevented from contacting the applicator bell cup when the applicator is energized or operating.

! WARNING

- Risk of arcing/fire hazard. The Aerobell 168 must be located a safe distance from the object to be sprayed, as well as all other grounded objects. The safe distance is 204mm (8”).

MATERIAL CONDUCTIVITY

The Aerobell 168 can be used with a full range of conductive coating materials. With coatings having higher conductivity, it may be necessary to isolate the material supply tank and hoses from ground. If there is any question as to the suitability of spraying a material with the Aerobell 168, contact your Ransburg distributor or representative. (See the following “Warning”.)

! WARNING

- Electrical discharge can cause fire or explosion. If arcing occurs when a specific coating material is used, turn the system off immediately and notify your coating supplier. Do not restart system until proper adjustments are made to your coating material.

BELL CUPS

Do not use any tools or sharp objects to stop the rotation of any bell cup. Doing so will result in damage to the plating material on the aluminum bell cups and may cause premature failure of the bell cup, or turbine.

TURBINE AIR - NOTE

If the turbine air is heated, check the maximum rated temperature for the air supply tubing to be used. Polyethylene tubing is rated for a maximum of 80° F (27° C). Nylon tubing is rated for 200°F (95°C) maximum.

TURBINE EXHAUST AIR

Turbine air must be able to exhaust freely, however too much exiting the rear of the manifold may cause a vacuum between the fluid tube and the turbine shaft. In the event of low to medium flow rates and mid to high turbine speeds, paint may be pulled back into the shaft and into the turbine motor. To provide a balance in this flow, plugs for unused ports have been installed into the Aerobell 168 Manifold assembly. See drawing below for restriction on their use.

⚠ WARNING

- Non ignitable cleaning fluids are preferred.
- Ignitable cleaning liquids shall only be used if, after disconnection of the high voltage supply, all parts under high voltage are discharged to an energy of less than 0.24mJ before these parts may be serviced.
- Appropriate measures shall ensure that the resistance to earth of the suspending point of the work piece shall not exceed 1MΩ measured at 500v or 1000v.
- Use only electrically conductive container for cleaning liquids; the containers must be earthed to ground.

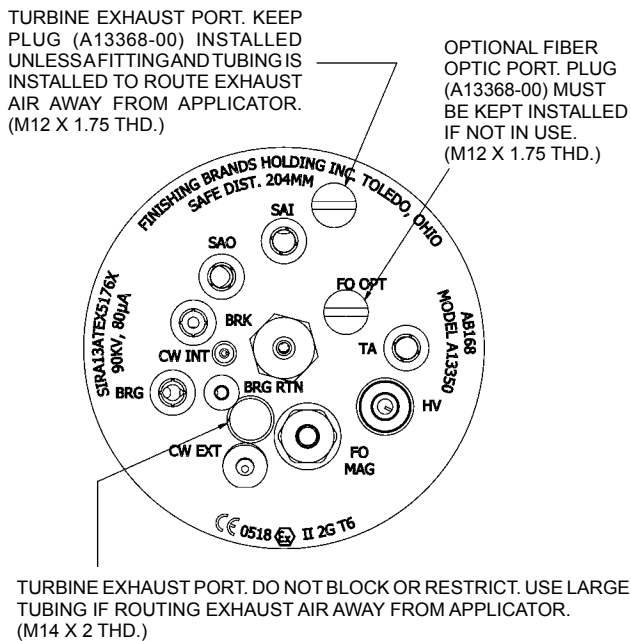

MAINTENANCE

Good maintenance is essential to safe and productive operation. Schedules should be established by the user, based on the following general information and observations of the initial production requirements.

The Ransburg maintenance and safety information should be made available to each operator.

Normal fire protection measures are necessary, including proper storage of paints and solvents and the proper disposal of waste. Ready access to appropriate fire extinguishing equipment is required. For details, consult the appropriate NFPA safety information, your local fire codes, local painting equipment standards, OSHA requirements, as well as your insurance carrier's information.

Refer to Appendix A for tests for stationary equipment and test frequency per EN 50 176.

! WARNING

- Unexpected robot movement can be hazardous. Do not adjust or repair the Aerobell 168 when the robot is operating or waiting to start. The robot must be locked out and secured against restart.
- Do not adjust or repair the Aerobell 168 when the power supply is ON. Secure the supply against a restart.
- Those solvents used for cleaning must have a flash point at minimum of 5°C (9°F) greater than ambient temperature. It is the end users responsibility to insure this conditions is met.
- Never remove Aerobell 168 while it is under pressure.
- If ignitable fluids are used for cleaning purposes, all parts must completely discharged of high voltage.

! WARNING

- Electrical shock/arcing and fire hazards can exist during maintenance. The high voltage must be turned off before entering the spray area and performing any maintenance procedures. Spray booth exhaust fan(s) should remain on while cleaning the equipment with solvents.
- Never touch the atomizer bell while it is spinning. The front edge can easily cut into human skin. Make sure the atomizer bell has stopped spinning before attempting to touch it. Wait at least a minimum of 1 minute after turbine air is off before touching the bell.

! CAUTION

- Do **not** immerse the Aerobell 168 turbine in solvent or other liquids. Turbine components will be damaged.
- Bearing air must be on during all cleaning procedures.
- If the Aerobell 168 is sprayed off with a solvent applicator for cleaning, the turbine should be turned on, as well as shaping air (high voltage off). Air exhaust from the turbine and shaping air form a curtain around the back edge of the bell, and help prevent solvent from getting into the cavity behind the bell. Do not direct at the opening behind the edge of the bell, as this may allow solvent to be forced into the turbine.

O-RINGS

All O-rings in this atomizer are solvent proof except the ones in the air bearing spindle. These O-rings must not be soaked in solvent; if these are exposed or soaked in solvent, they must be replaced. These O-rings are engineered to provide a fit between the air bearing spindle and its mating parts to reduce or eliminate harmonic resonance (vibration).

Some O-rings are PTFE encapsulated. These O-rings have a limited amount of stretch and will not return to their original diameters if over-stretched. These O-rings are subject to being distorted more easily than rubber O-rings, so it is important that they be sufficiently lubricated when mating parts are installed onto them. They also will take a square set over time and should be replaced periodically if mating parts are removed repeatedly or if a new mating part is installed onto them.

Any O-ring that is cracked, nicked, or distorted must be replaced.

A suitable lubricant is food grade petroleum jelly or A11545-00 Petrolatum Jell.

Cleaning Procedures

The precise sequence of flushing the system of paint will vary according to the type of color valve arrangement used, and other automatic features built into the system. But follow these basic procedures when cleaning:

1. Verify high voltage is off.
2. With the bearing air and turbine air on, flush paint out of material lines with solvent. Flushing should be done before any break in production. If the Aerobell 168 is mounted vertical-facing up, rotate to horizontal plane before flushing or cleaning.
3. Flushing should be done with the atomizer bell cup installed. The bell cup will normally be fully cleaned with flushing. However, if there is any remaining paint build up on any areas of the bell after flushing, the bell should be removed for hand cleaning.

4. Clean the bell cup by soaking in an appropriate solvent as long as necessary to loosen paint. Use a soft bristle brush dipped in solvent to remove paint. Make sure all signs of paint are removed (See the following "Warning"). Rinse and dry bell. Using a non-metallic item (toothpick), clean the center holes of the splash plate. Using plenty of cleaning fluid, flush these holes towards rear of bell cup. Make sure these holes are clean.

5. Before reinstalling the bell onto the shaft, check the tapered mating surfaces of the turbine shaft and bell for any paint residue. Clean any residue. (See "Warning" below.)

6. Clean the exterior of the Aerobell 168. (See "Warning" below.)

7. Do not reuse an atomizer bell that shows signs of damage such as nicks, heavy scratches, dents, or excessive wear.

8. Periodic cleaning of the holes in the shaping air ring will prevent paint build-up which does affect pattern control or cause defects in parts being coated. Follow "Cleaning Shaping Air Holes and Annulus" in the "Maintenance" section and clean the slots of the shaping air ring using a soft bristle brush.

To prevent paint build-up in holes of shaping air ring while installed, clean shroud assembly with shaping air ON. Clean with a damp rag or soft bristle brush. Do not soak or saturate area to force fluid or paint into the holes or annulus (70-100 SLPM of shaping air is recommended).



CAUTION

- Using as atomizer bell with paint buildup will cause a bell imbalance. An imbalance bell may cause bearing damage and turbine failure. Also, any paint residue caught between the tapered surfaces can prevent the bell from seating properly and result in an imbalance condition.

**WARNING**

➤ Those solvents used for cleaning must have a flash point at minimum of 5°C (9°F) greater than ambient temperature. It is the end users responsibility to insure this conditions is met. Also, since electrostatic equipment is involved, these solvents should be non-polar. Example of non-flammable, non-polar solvents for wipe down are: amyl acetate, methyl amyl acetate, high flash naphtha, and mineral spirits.

a. If using a rag to hand wipe the Aerobell, turbine air should be off, but leave shaping air on. 70-100 SLPM for shaping air is recommended.

b. Do not use conductive solvents such as . MEK to clean the Aerobell 168.

Vibration Noise

If the Aerobell 168 is vibrating or making an unusually loud noise, it usually means there is an imbalance situation. The atomizer bell may have dried paint on it, or the bell may be physically damaged, or there may be paint trapped between the bell and shaft preventing the bell from properly seating. If any of these conditions exist, they **must** be corrected. Excessive imbalance caused by one of these conditions may result in bearing damage and turbine failure. Warranty **DOES NOT** cover failure caused by imbalanced loading conditions.

To determine if the bell is dirty or damaged, remove the bell and turn the turbine on. If the noise is eliminated, the bell cup is the problem. If the noise continues, the turbine may be damaged and should be inspected. Excessive air required to achieve same speed may indicate a faulty or contaminated turbine. **DO NOT** continue to operate a noisy turbine.

PREVENTIVE MAINTENANCE

(See “Preventive Maintenance Schedule”)

Daily/Weekly Maintenance

➤ Due to the close proximity of high voltage to ground potential, a schedule must be developed for equipment maintenance (cleanliness).

➤ Verify that high voltage is OFF and that shaping air, bearing air, and turbine drive air are ON.

➤ Open the dump valve, if equipped, flushing all paint from the supply lines and valve module.

➤ Open the solvent valve, if equipped, flushing all paint from the fluid tube and through the atomizer bell assembly.

➤ Verify that high voltage is OFF, turbine drive air is OFF, and that the bell cup has stopped spinning. The bearing air and shaping air should remain ON.

➤ Clean all external surfaces of the applicator using a lint-free rag dampened with solvent. External surfaces include the shroud and valve module.

➤ After cleaning, all conductive residue must be removed using a non-conductive solvent. since electrostatic equipment is involved, these solvent should also be non-polar.

➤ Inspect bell cup for nicks, dents, heavy scratches, or excessive wear. Replace if necessary.

⚠ WARNING

➤ The high voltage must be turned OFF before entering the spray area and performing any maintenance procedures. Spray booth exhaust fan(s) should remain ON while cleaning the equipment with solvents.

Internal Fluid Path Purge Cleaning and Load

Cleaning the incoming paint line (from paint supply source such as color manifold through the fluid manifold and bell assembly):

Open the dump valve and flush the incoming paint line with solvent or an air/solvent chop. Make sure the last step of the sequence is air to purge the dump line of remaining solvent. To speed the loading of the new paint, leave the dump line open to allow the air in front of the paint push to escape. The length of time the dump valve is open depends on several factors such as viscosity, paint pressure, etc. Timing should be such that the dump is closed as the paint reaches the trigger valve in the atomizer. Paint in the dump line may cause high voltage issues.

External Atomizer Surface Cleaning

➤ Verify that the high voltage is turned off.

All external surfaces may be cleaned using a mild solvent and lint free rags to hand wipe. Turbine drive air must be off, but leave bearing air on. The shaping air should have approximately 70 SLPM air flow through each to prevent the solvent from entering these passages.

➤ Do not spray the unit with a solvent applicator used for cleaning. The cleaning fluid under pressure may aid conductive materials to work into hard to clean areas or may allow fluids to be forced into the turbine assembly.

Do not reuse an atomizer bell cup that shows any sign of damage such as nicks, heavy scratches, dents, or excessive wear.

Always final wipe all parts with a non-polar solvent and wipe dry (high flash Naphtha, etc.).

Bell Cup Cleaning (Cup Wash) (Without Cleaning the Incoming Paint Line)

Turn off the high voltage and trigger valve. With the bell spinning at 30,000 rpm, turn on the external solvent valve to allow cleaning solvent to flow through the manifold passages, through the fluid tube, and into the bell cup. The spinning bell will atomize the solvent, clean out the bell passages. It is always recommended to blow the solvent line dry after the cleaning operation. Typical bell speed during the cup flush sequence is 30,000 rpm.

⚠ WARNING

➤ **Never** wrap the applicator in plastic to keep it clean. A surface charge may build up on the plastic and discharge to the nearest ground object. Efficiency of the applicator will also be reduced and damage of failure of the applicator components may occur. **WRAPPING THE APPLICATOR IN PLASTIC WILL VOID WARRANTY.**

! WARNING

- To reduce the risk of fire or explosion. Solvents used for cleaning must have a flash point at minimum of 5° C (9°F) greater than the ambient temperature. It is the end users responsibility to insure this condition is met. Since electrostatic equipment is involved, these solvents should also be non-polar. Example of non-flammable, non-polar solvents for cleaning are: amyl acetate, methyl amyl acetate, high flash naphtha, and mineral spirits.
- Use a solvent compatible with the coating being applied to clean the exterior of the applicator . Use VM & P Naptha as a final wipe to remove surface conductivity.
- When using a rag to hand wipe the Aerobell, the turbine air should be off, but leave both the shaping air and bearing air turned on. Ensure that rotation has come to a complete stop.

AIR FILTERS / ELEMENT REPLACEMENT

! WARNING

- Introducing air which contains oil, moisture, and dirt may cause wear and damage to the bearings. It is the user's responsibility to monitor the quality of air and to replace the filter elements as often as necessary. Turbine failure caused by poor air quality will not be covered under warranty.

REPLACEMENT ELEMENTS		
Part #	Qty. Elements Per Carton	Used On
HAF-503	1	HAF-15, Pre-Filter
HAF-508	4	HAF-38, Pre-Filter
RPM-418	8	RPM-418, Bearing Air Filter

Ransburg Aerobell systems should include a pre-filter(s) and final filters for all air to the Aerobell 168 unit. The final filter is for bearing air only. All filters contain elements that must be replaced on a regular basis to assure clean air. HAF-508 and RPM-418 filters also contain an automatic drain and pressure differential indicator.

The pressure differential indicator provides a visual indicator that pops up (becomes more visible) as the filter element becomes plugged. Replace the filter elements when the visual indicator becomes visible, don't wait until it pops up fully. As the elements become plugged, their efficiency drops. The frequency of filter element change will depend upon the quality of the plant air. It is recommended that all elements be replaced at least every 4 to 6 months.

In plants where heavy amounts of oil and moisture vapor are present in the air lines, a refrigerated air dryer may be necessary.

The Aerobell 168 is designed to give dependable service and extended life. One of the most important factors in realizing long life is the quality of air. It is therefore essential for the user to closely monitor the quality of their air and to properly maintain the air filters by replacing the filter elements as often as necessary. (Replace elements at least every 4-6 months or more often.)

Atomizer Bell Assembly

Inspect the atomizer bell assembly for any damage, wear, or paint build-up every day.

BELL CUP CLEANINGS

Always verify that high voltage is off and that the atomizer bell is spinning before performing any type of bell flush cleaning cycle.

To reduce the risk of fire or explosion, the solvents used for exterior surface cleaning must have flash points above 5°C (9°F) greater than the ambient temperature. Since electrostatic equipment is involved, these solvents must also be non-polar.

Solvents used for equipment flushing should have flash points equal to or higher than those of the coating material being sprayed.

1. The atomizer bell will normally be fully cleaned during a bell flush cycle. Flushing should be done before any down time or break in production. A bell flush cycle may also be required while spraying batch parts of the same color. Verify that high voltage is off and that the atomizer bell is spinning before flushing through the bell.

2. If there is any remaining paint build-up on any areas of the bell after flushing, the bell should be removed for hand cleaning. The bell's leading edge, splash plate, and serration cuts are some examples of areas for special attention.

Manual Inspection

3. Visually inspect the bell cup edge for signs of abrasion. If the edge is worn or chipped as the result of a collision with a part, replace the cup immediately.

4. Remove splash plate. Inspect for wear on the bell cup where the fluid leaves the large diameter of the splash plate. If any undercut in this area, the cup should be replaced. If worn, replace entire splash plate assembly.

5. Splash plates may be soaked to loosen dried material. Clean with a soft bristle brush. Blow out center holes to dislodge material. Never use any kind of pick instrument to clean these holes, as it will damage them.

6. Soaking the bell in solvent may aid in loosening or removing paint build-up. It is recommended that the splash plate be removed and cleaned separately.

7. Use a soft bristle brush dipped in solvent to remove paint build-up from the serration cuts, paint feed holes or slots, and external and internal surfaces of the bell.

8. A soft, lint free rag dampened with solvent may be used to remove any paint residue from the external and internal surfaces of the atomizer.

9. After removing all paint build-up or residue, rinse the bell in clean solvent and blow dry.

10. Before reinstalling the bell on the shaft, check the mating surfaces of the thread and taper for any paint build-up or residue. Also, check the fluid tip, fluid tube outside diameter, and the shaft for any further paint build-up. These surfaces should be cleaned before installing the bell.

11. It is recommended that extra bell cups be purchased. The cups can then be cleaned off-line in an automated cup cleaner when the second set is in production.

12. Reinstall cups to hand tighten torque .

Bell Cup Soaking

Bell cups and splash plates can be soaked in a heated solution for up to 2 hours in an ultrasonic cleaner (120°F (49°C) maximum).

CLEANING SHAPING AIR HOLES

In order to maintain uniform pattern control, the shaping air holes of the inner ring and the shaping air cap must be clean and free of any blockage.

It is best to leave the shaping air supply ON during normal production break cleaning periods. Shaping air can be reduced to 70 slpm during this time. This will help material from entering the passage ways.

Periodically (weekly or sooner) the outer shaping air cap and the inner shaping air ring should be removed and thoroughly cleaned. Use of an ultrasonic cleaner would make cleaning of hole diameters easier. Inspect all holes for blockage. Blow holes clear with compressed air after some time of soaking in solvent. **DO NOT use any type of pick to clear the holes.** Damage may result to parts and could affect performance of the equipment. If holes are damaged (oversized holes, blockage, gouges) it must be replaced.

Inspect Bell Cup Daily

Check for signs of damage such as nicks, heavy scratches, dents, or excessive wear. Replace the cup assembly with any of these conditions.

Resistor Assembly (Resistance Verification)

Using a yokogama megohm meter or equivalent. Set the meter to the 1000V scale. Touch one lead to the flat exposed end of the resistor and the other lead to the contact spring on the resistor. The reading must be between 54-66 megohm. Replace resistor assembly if required.



AEROBELL 168 PREVENTIVE MAINTENANCE SCHEDULE								
Procedure	Frequency (Maximum)							
	Mid-Shift	End of Shift	Weekly	2 Weeks	Monthly	3 Months	6 Months	Yearly
Mid Shift Cleaning • Wipe shroud • Visually inspect cup	●							
End of Shift Cleaning • Wipe shroud • Wipe bell cup down • Change cloth cover		●						
Shaping Air Shroud and Cap • Clean shroud • Clean shape air cap	●	●	●					
Bell Cup Removal/Inspection/ Cleaning/Tightening		●	●					
Fluid tip inspection/cleaning		●	●					
Inspect Valve and Seat Assembly for leaking				●				
Replace Valves and or Seats in valve module							●	●
Verify Resistance of High Voltage Resistor						●	●	
High Voltage Cable Inspections			●					
High Voltage Testing							●	
Inspect all screws • Replace if broken • Inspect for wear • Tighten per specifications					●			
Inspect Turbine Spindle Taper and Threads	●							
Replace Bell Cups						●	●	●
Replace Splash Plates						●	●	●
Inspect and Clean • Spindle • Bore • Fluid Tube OD		●	●					
Inspect for Fluid Leaks	Daily							

TOOLS REQUIRED TO DISASSEMBLE AEROBELL

Use the following tools to disassemble the Aerobell 168. (Tool Kit A13082-XX)

A11229-00 Fluid Tip/Tube Removal Tool



RPM-419 Bell Cup Combo Wrench

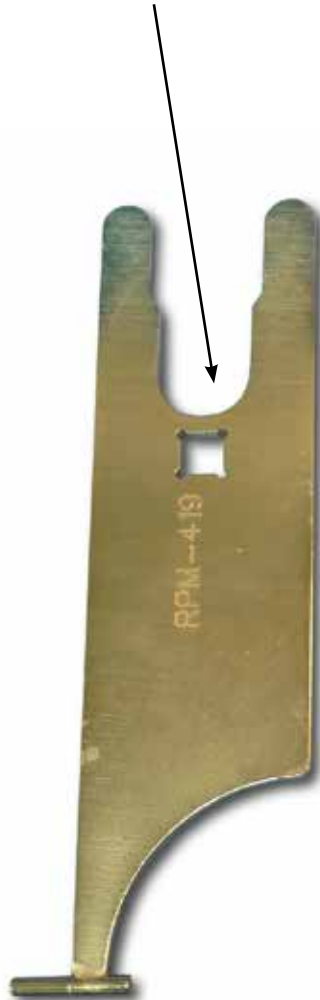

Adjustable Wrench **Not** Supplied in Tool Kit



A12899-00 Bell Cup Removal Tool



59972-00 Dielectric Grease Not Supplied in Tool Kit



A12088-00 Turbine Retaining Ring Wrench

OPTIONAL TOOLS REQUIRED TO DISASSEMBLE AEROBELL

Use the following optional tools to disassemble the Aerobell 168.

A11388-00
Splash Plate
Removal Tool

A11922-00
Microvalve
Removal Tool

A10766-00
Microvalve Seat
Removal Tool

5mm Hex Key
Wrench
NOT supplied
with the tool kit

5/16" (8mm) Hex
Key Wrench
NOT supplied with
the tool kit

3/8" Hex Key
Wrench
NOT supplied
with the tool kit

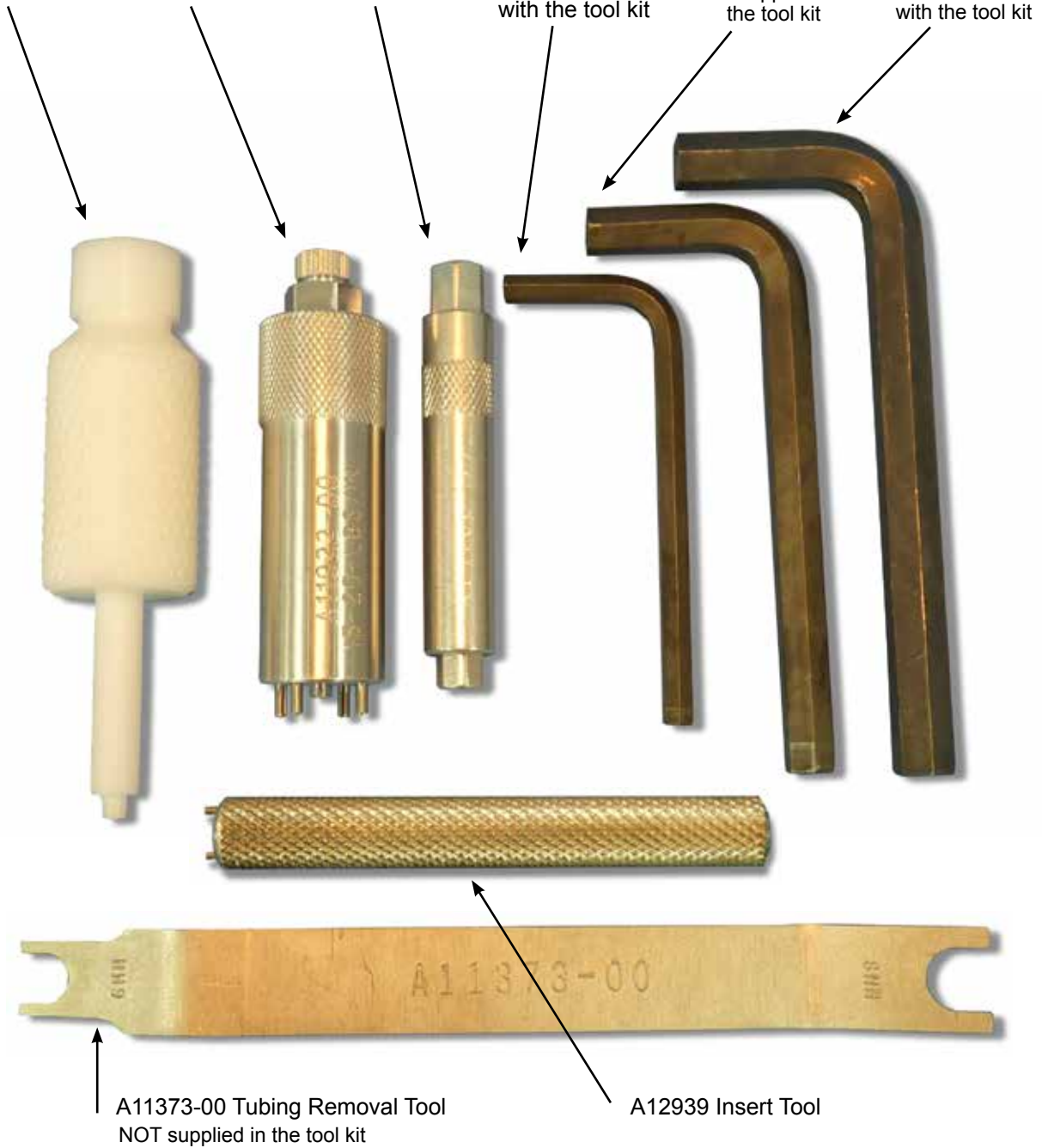

A11373-00 Tubing Removal Tool
NOT supplied in the tool kit

A12939 Insert Tool

DISASSEMBLY PROCEDURES (15mm Bell Cup and Shape Air Ring)

NOTE

- Mean time to repair entire assembly is 60 Minutes.

Step 1

Place the Aerobell 168 on a clean stable working surface or mount.



Step 2

Remove the Shaping Air Shroud by hand (no tool required).



DISASSEMBLY PROCEDURES (15mm Bell Cup and Shape Air Ring)

Step 3

Locate the Cup Wash Fitting that is mounted on the Shape Air Ring.

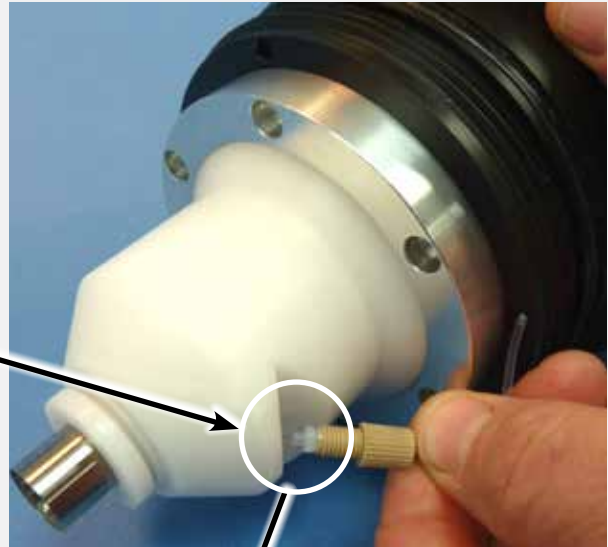

Step 4

Make sure when assembling the Cup Wash Fitting that the ferrule taper end is inserted into the Cup Wash Fitting.

Remove the Cup Wash Fitting from the Shape Air Ring.

When assembling the Cup Wash Fitting, tighten with fingers until an audible “click” is heard.

Note: Be careful ***NOT*** to drop the Cup Wash Ferrule.

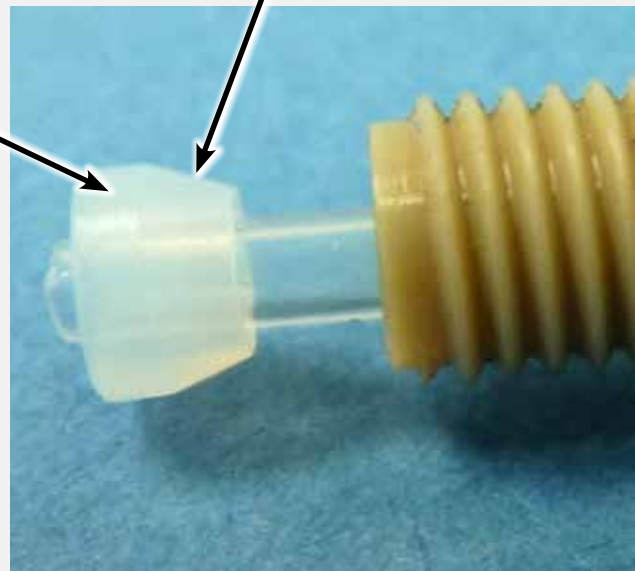

DISASSEMBLY PROCEDURES (15mm Bell Cup and Shape Air Ring)

Step 4a

Remove Spacer A12934-00



Step 4b

With a delicate pointed tool
remove O-Ring 79001-57.

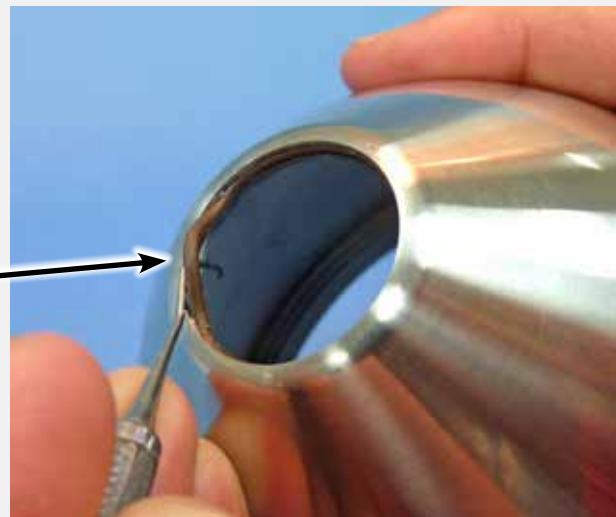

When installing new O-Ring
79001-57 use caution, and no
sharp tools, to prevent damage.

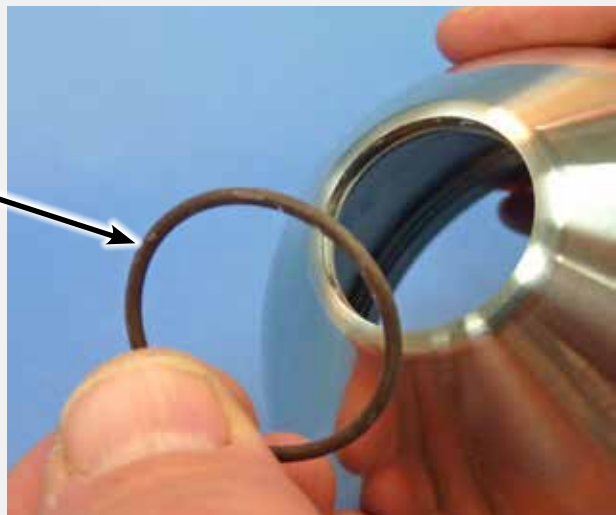

DISASSEMBLY PROCEDURES (15mm Bell Cup and Shape Air Ring)

Step 5

Remove Shape Air Ring. Pull straight off.

Note: The Shape Air Ring is sealed with a O-ring and may be difficult to remove.

Note: When reassembling an audible "Click" should be heard.

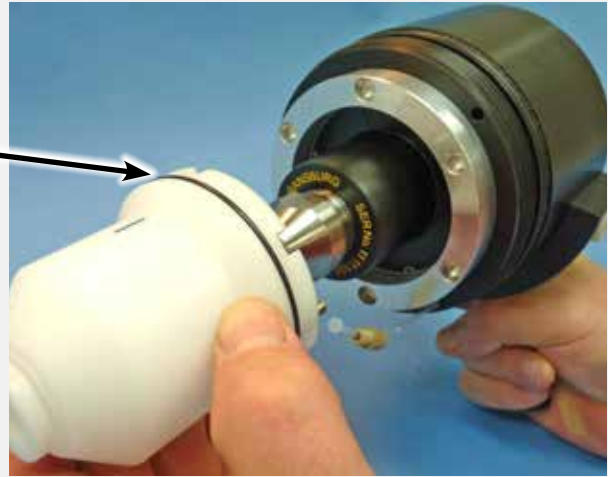

Step 6

Yellow Dot
Yellow Line
Blue Line

Note: The Shape Air Ring has a blue alignment mark . The blue alignment mark will line up with the yellow dot located on the Atomizer Body and the small yellow line located on the Turbine. All three (3) alignment marks will have to be in line when assembling.

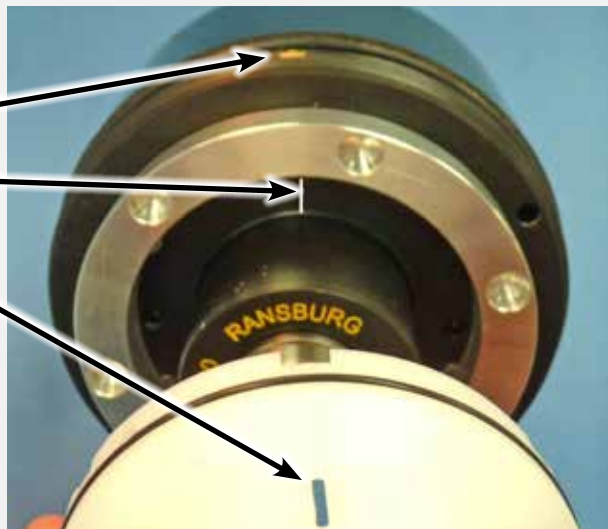

Step 7

Note: Two (2) locating pins are mounted on the back of the Shape Air Ring to insure proper alignment.

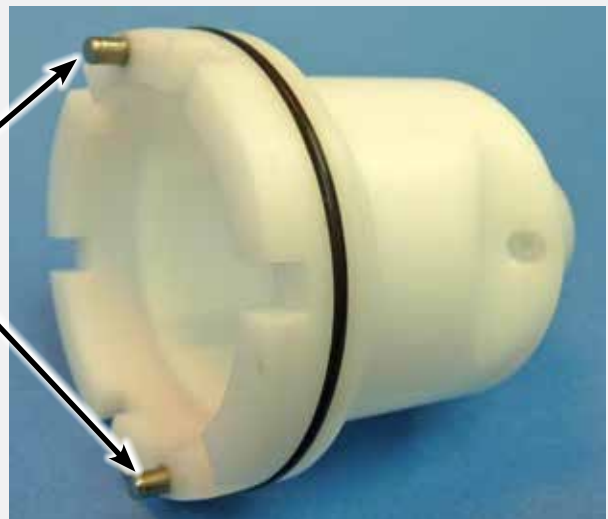

DISASSEMBLY PROCEDURES (15mm Bell Cup and Shape Air Ring)

Step 8

Insert the Bell Cup/ Combo Wrench (RPM-419) across the flats located on the Turbine. Re-move the Bell Cup by hand

Bell Cup

When reassembling the Bell Cup hand tighten is sufficient.



Step 9

The Bell Cup should turn easily by hand.

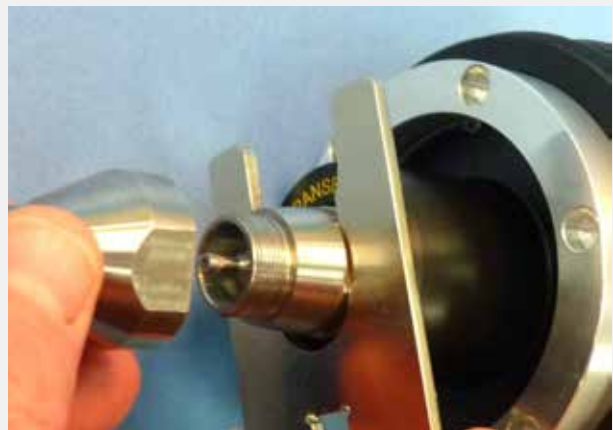

Step 10

Locate the Bell Cup Insert (A12938-00) that is screwed into the Bell Cup.

Note the two (2) holes located in the Bell Cup Insert.

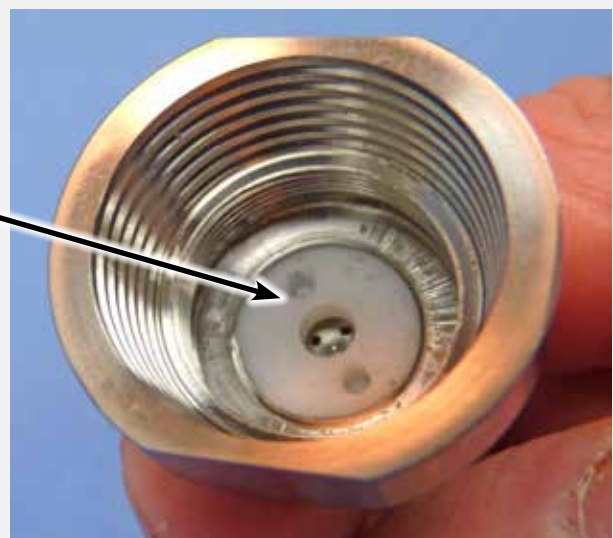

DISASSEMBLY PROCEDURES (15mm Bell Cup and Shape Air Ring)

Step 11

Insert the Insert Tool (12939) into the two (2) holes in the Bell Cup Insert located on the back side of the Bell Cup.

Remove the Bell Cup Insert.

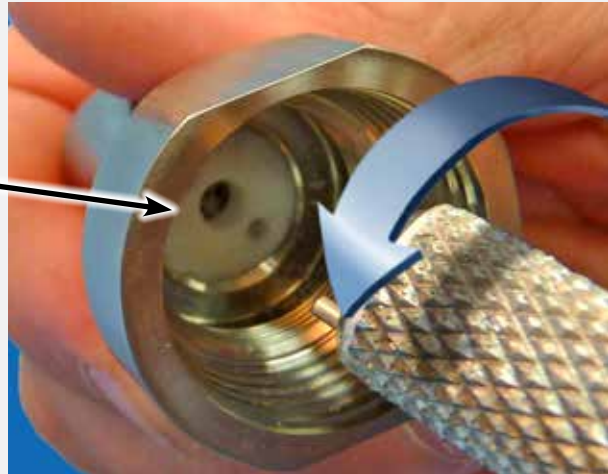

Step 12

15mm Bell Cup

Insert Tool A12939-00

Bell Cup Insert

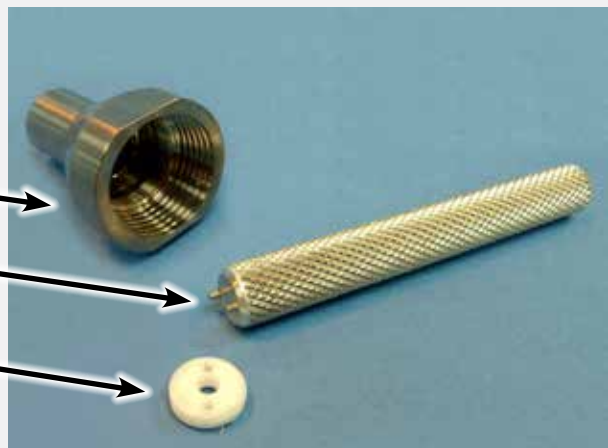

Step 13

Use care when inserting the Bell Cup Insert to prevent stripping the threads.

Note:

To continue the process of disassembly procedures of the Aerobell 168 go to Step 14 on page 67



DISASSEMBLY PROCEDURES (30mm Bell Cup and Shape Air Ring)

NOTE

➤ Mean time to repair entire assembly is 60 Minutes.

Step 1

Place the Aerobell 168 on a clean stable working surface or mount.



Step 2

Remove the Shaping Air Shroud by hand (no tool required).



Step 3

Locate the Cup Wash Fitting that is mounted on the Shape Air Ring.



DISASSEMBLY PROCEDURES (30mm Bell Cup and Shape Air Ring)

Step 4

Remove the Cup Wash Fitting from the Shape Air Ring.

When assembling the Cup Wash Fitting, tighten with fingers until an audible “click” is heard.

Note: Be careful *not* to drop the Cup Wash Ferrule.

Make sure when assembling the Cup Wash Fitting that the ferrule taper end is inserted into the Cup Wash Fitting.

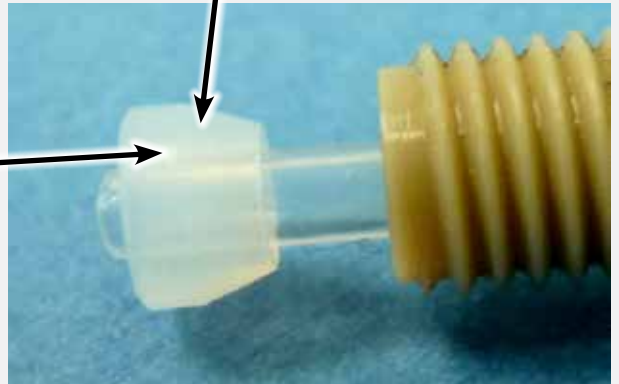

Step 5

Remove Shape Air Ring.
Pull straight off.

Note: The Shape Air Ring is sealed with a O-ring and may be difficult to remove.

Note: When reassembling an audible “Click” should be heard.

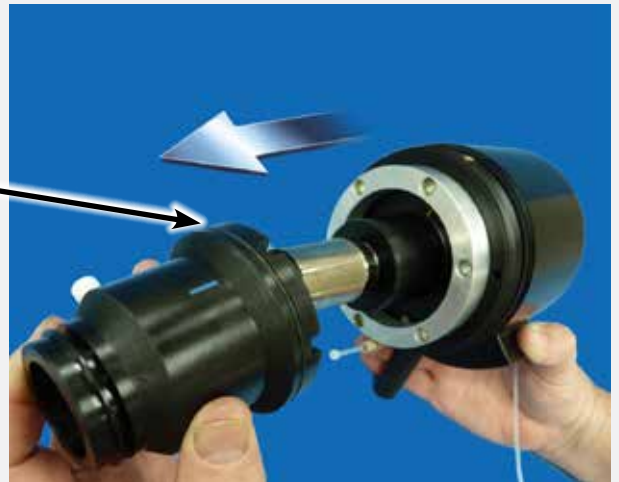

DISASSEMBLY PROCEDURES (30mm Bell Cup and Shape Air Ring)

Step 6

Yellow Dot
Yellow Line
Blue Line

Note: The Shape Air Ring has a blue alignment mark. The blue alignment mark will line up with the yellow dot located on the Atomizer Body and the small yellow line located on the Turbine. All three (3) alignment marks will have to be in line when assembling.

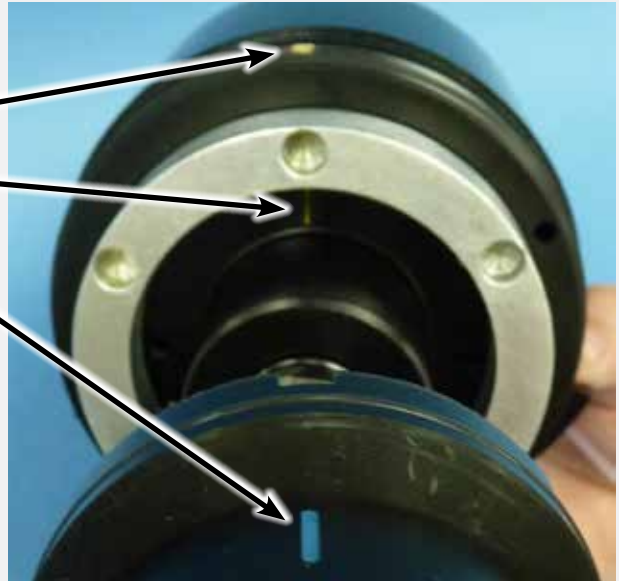

Step 7

Note: Two (2) locating pins are mounted on the back of the Shape Air Ring to insure proper alignment.



Step 8

Insert the Bell Cup/ Combo Wrench (RPM-419) across the flats located on the Turbine. Remove the Bell Cup by hand.

Bell Cup

When reassembling the Bell Cup hand tighten is sufficient.

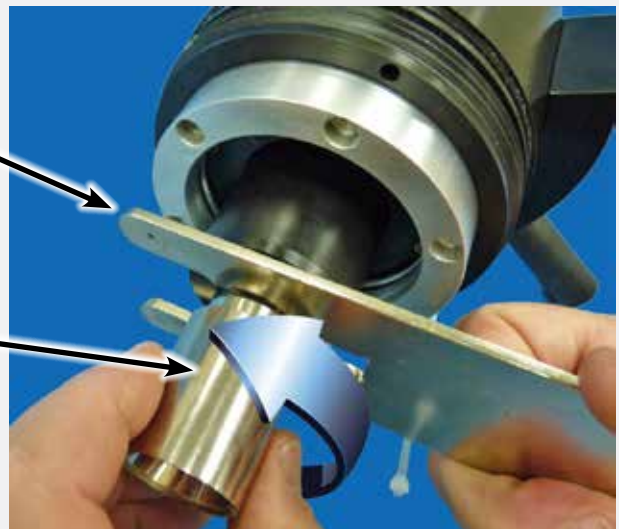

DISASSEMBLY PROCEDURES (30mm Bell Cup and Shape Air Ring)

Step 9

The Bell Cup should turn easily by hand.

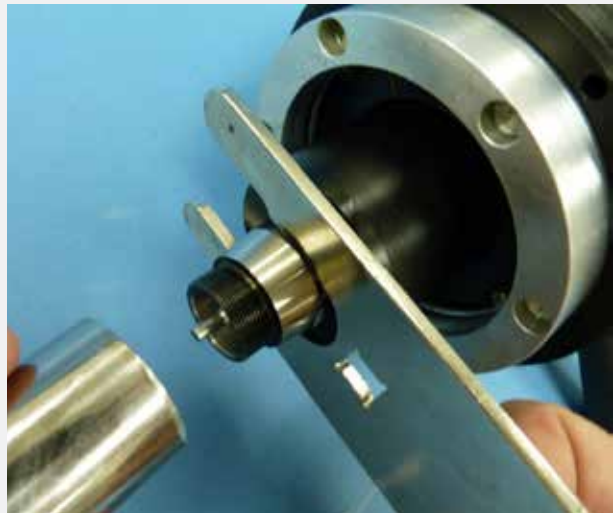

Step 10

Locate the Splash Plate that is pressed into the Bell Cup.

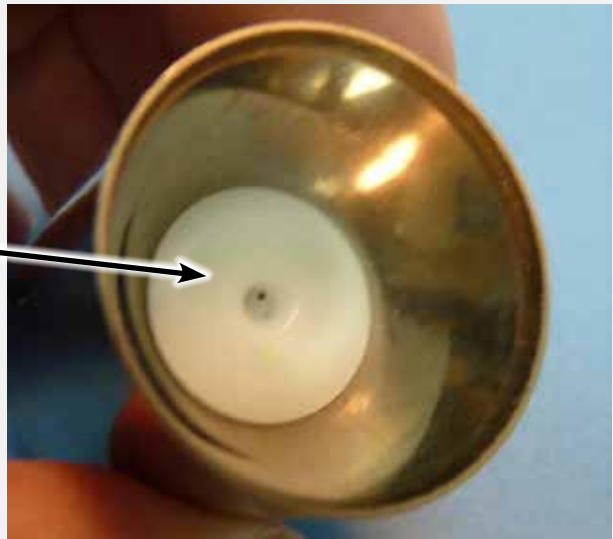

Step 11

Insert the narrow end of the Splash Plate Removal Tool (A11388-00) into the hole on the back side of the Bell Cup. Using a hard thrust from the palm of your hand, remove the Splash Plate.



DISASSEMBLY PROCEDURES (30mm Bell Cup and Shape Air Ring)

Step 12

30mm Bell Cup

Splash Plate

A11388-00 Splash
Plate Removal Tool

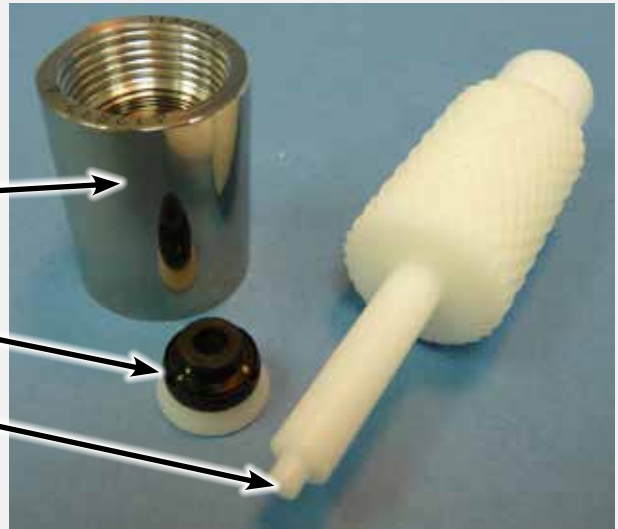

Step 13

To reassemble the Splash Plate, place the Bell Cup with the back down on a flat surface and insert the Splash Plate into the Bell Cup hole. Using the large end of A11388-00 Splash Plate Removal Tool gently push into position. Until an audible “click” is heard.

Note:

To continue the process of disassembly procedures of the Aerobell 168 go to Step 14 on page 67

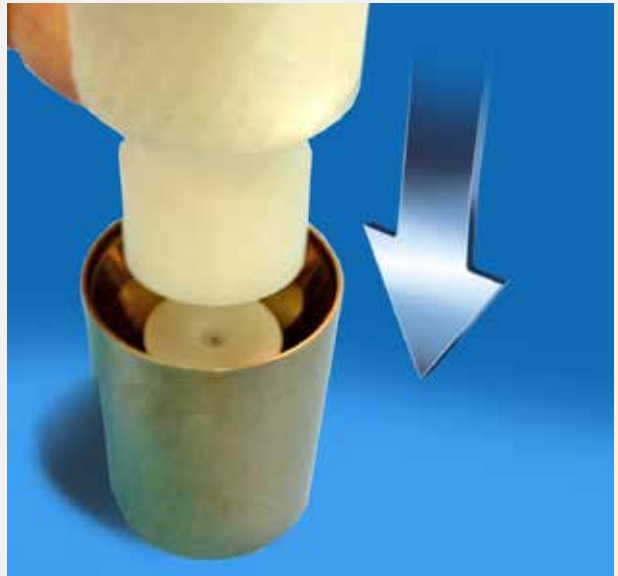

Step 13A

Verify depth of insert to
dimension shown

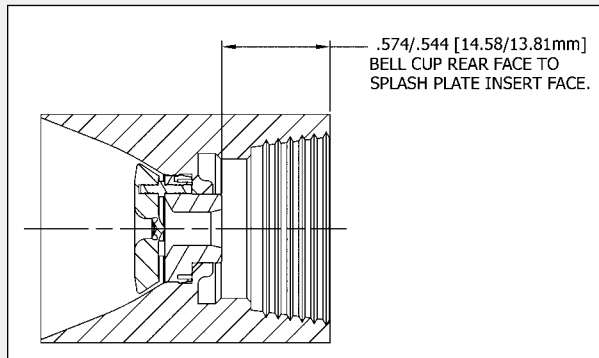

.574/.544 [14.58/13.81mm]
BELL CUP REAR FACE TO
SPLASH PLATE INSERT FACE.

DISASSEMBLY PROCEDURES (65mm Bell Cup and Shape Air Ring)

NOTE

➤ Mean time to repair entire assembly is 60 Minutes.

Step 1

Place the Aerobell 168 on a clean stable working surface or mount.



Step 2

Remove the Shaping Air Shroud by hand (no tool required).



Step 3

Locate the Cup Wash Fitting that is mounted on the Shape Air Ring.



DISASSEMBLY PROCEDURES (65mm Bell Cup and Shape Air Ring)

Step 4

Remove the Cup Wash Fitting from the Shape Air Ring.

When assembling the Cup Wash Fitting, tighten with fingers until an audible “click” is heard.

Note: Be careful ***not*** to drop the Cup Wash Ferrule.



Make sure when assembling the Cup Wash Fitting that the ferrule taper end is inserted into the Cup Wash Fitting.

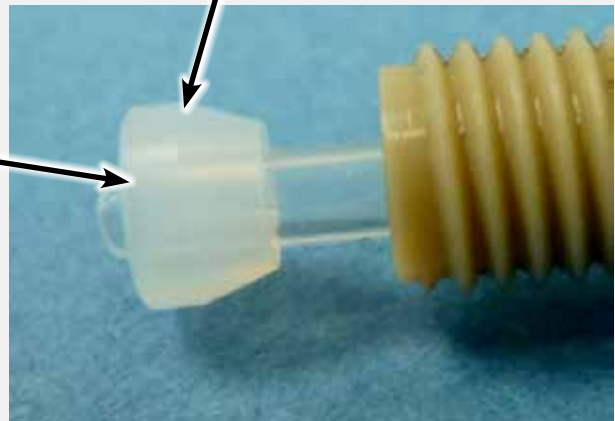

Step 5

Insert the Bell Cup Removal Tool(A12899) in the hole located on the Shape Air Ring and align with the hole in the Turbine Shaft.



DISASSEMBLY PROCEDURES (65mm Bell Cup and Shape Air Ring)

Step 6

The Bell Cup should turn easily by hand.

When reassembling the Bell Cup hand tighten is sufficient.

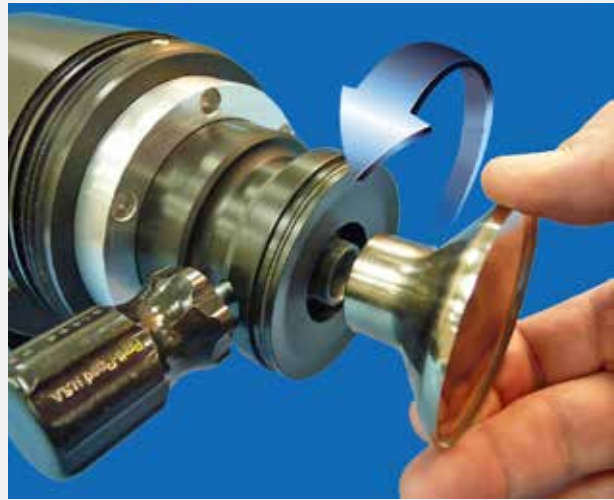

Step 7

Remove Shape Air Ring. Pull straight off.

Note: The Shape Air Ring is sealed with a O-ring and may be difficult to remove.

Note: When reassembling an audible “Click” should be heard.



Step 8

Yellow Dot
Yellow Line
Blue Line

Note: The Shape Air Ring has a blue alignment mark . The blue alignment mark will line up with the yellow dot located on the Atomizer Body and the small yellow line located on the Turbine. All three (3) alignment marks will have to be in line when assembling.

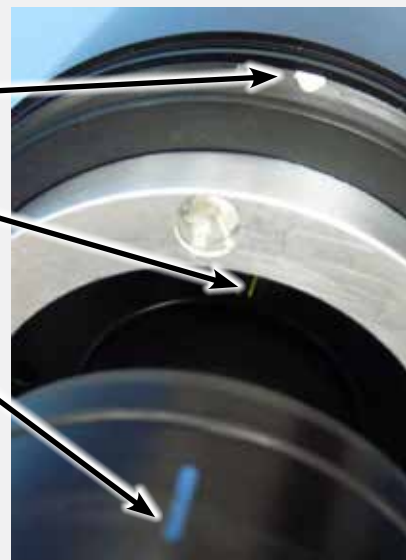

DISASSEMBLY PROCEDURES (65mm Bell Cup and Shape Air Ring)

Step 9

Note: Two (2) locating pins are mounted on the back of the Shape Air Ring to insure proper alignment.

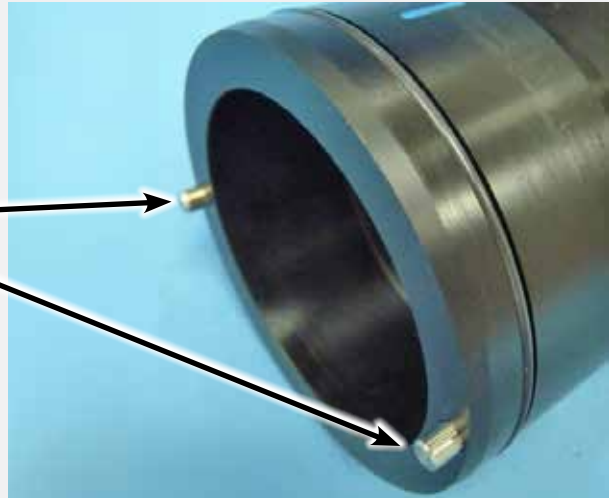

Step 10

Locate the Splash Plate that is pressed into the Bell Cup.

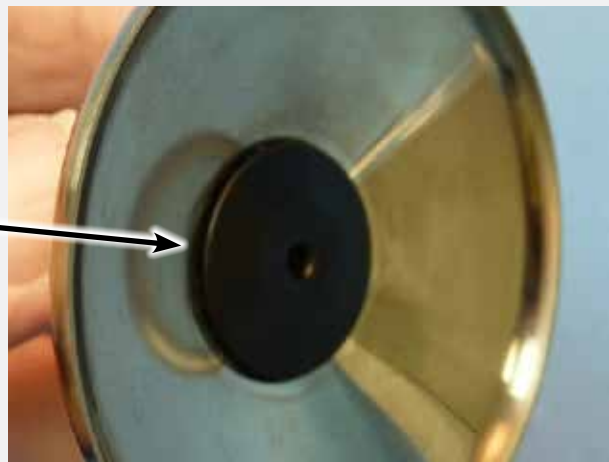

Step 11

Insert the narrow end of the Splash Plate Removal Tool (A11388-00) into the hole on the back side of the Bell Cup. Using a hard thrust from the palm of your hand, remove the Splash Plate



DISASSEMBLY PROCEDURES (65mm Bell Cup and Shape Air Ring)

Step 12

65mm Bell Cup

A11388-00 Splash Plate
Removal Tool

Splash Plate

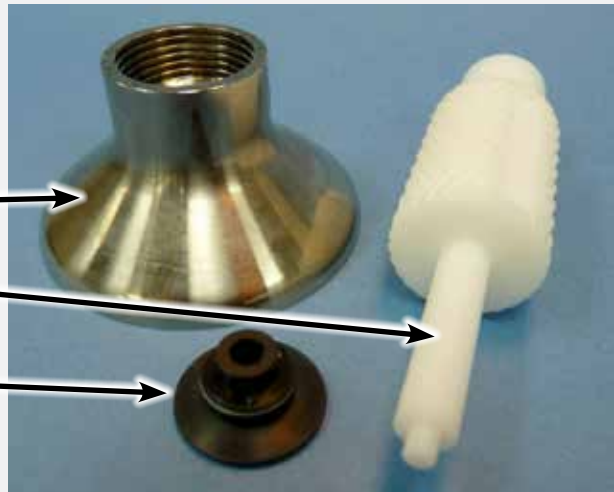

Step 13

To reassemble the Splash Plate, place the Bell Cup with the back down on a flat surface and insert the Splash Plate into the Bell Cup hole. Using the large end of A11388-00 Splash Plate Removal Tool gently push into position. Until an audible “click” is heard.

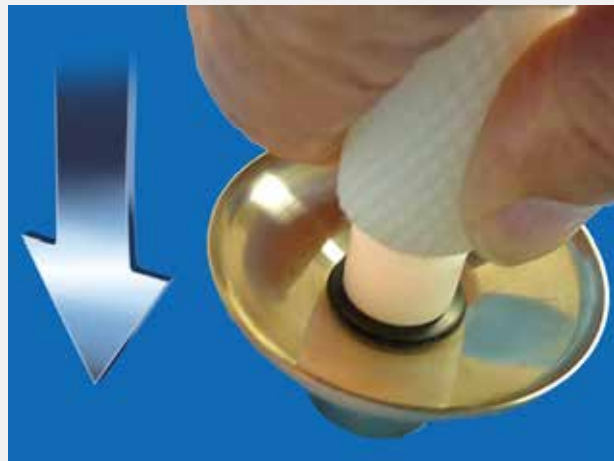

Step 13A

Verify depth of insert to
dimension shown

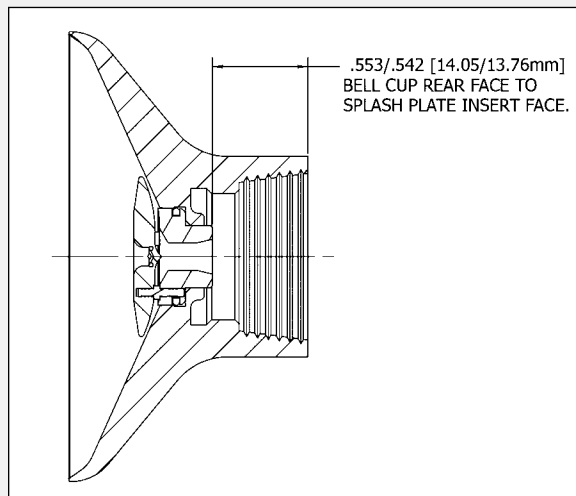

DISASSEMBLY PROCEDURES (65mm Bell Cup and Shape Air Ring)

Step 14

Remove the Fluid Tip using the A11229-00 Fluid Tip/Tube Removal Tool.

NOTE

➤ The Threads on the Fluid Tips are LEFT HANDED.

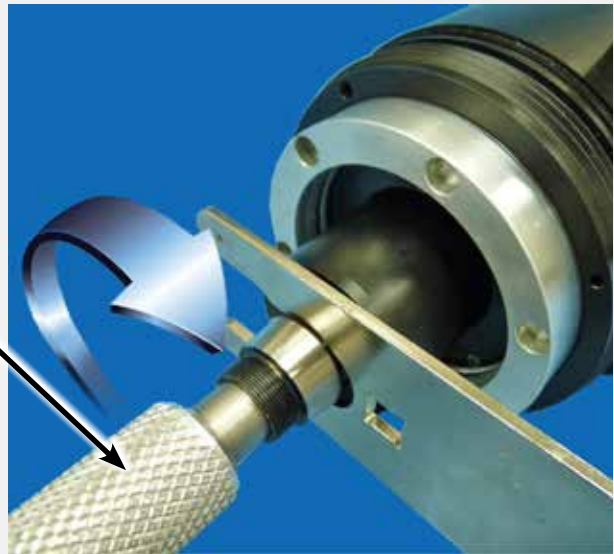

Step 15

The Fluid Tip should only be hand tighten when assembled.

Note: There is an O-ring behind the Fluid Tip. Take care not to lose.

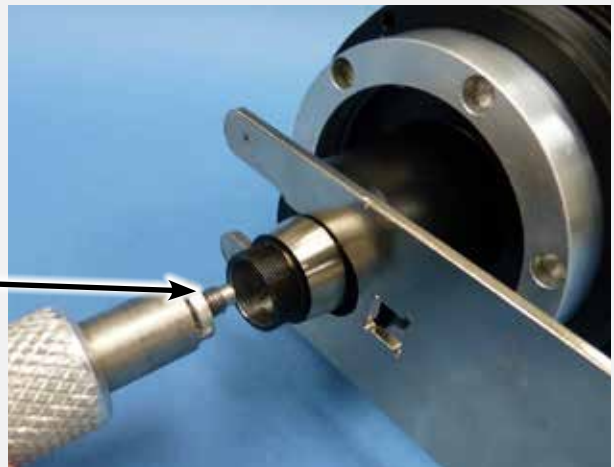

Step 16

Using the Turbine Retaining Ring Tool (A12088-00) remove the Turbine Retaining Ring.



DISASSEMBLY PROCEDURES (65mm Bell Cup and Shape Air Ring)

Step 17

Yellow Dot
Yellow Line

Note the alignment marks on the Atomizer Body and Turbine Retaining Ring.



Step 18

Remove the Turbine (no tool required).
Pull straight off.

NOTE

➤ The Turbine sealed with a O-ring and may be difficult to remove



Step 19

Note the alignment marks.



DISASSEMBLY PROCEDURES (65mm Bell Cup and Shape Air Ring)

Step 20

Note: Two (2) locating pins are mounted on the back of the Turbine to insure proper alignment.

When assembling these pins will easily insert when the alignment marks are properly matched.

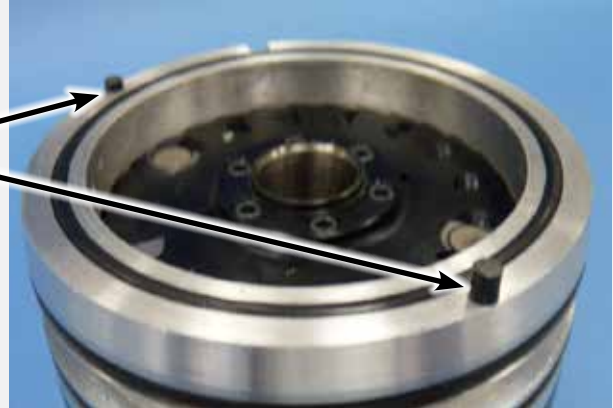

Step 21

Locate the Fluid Tube and Fluid Tube Retainer.

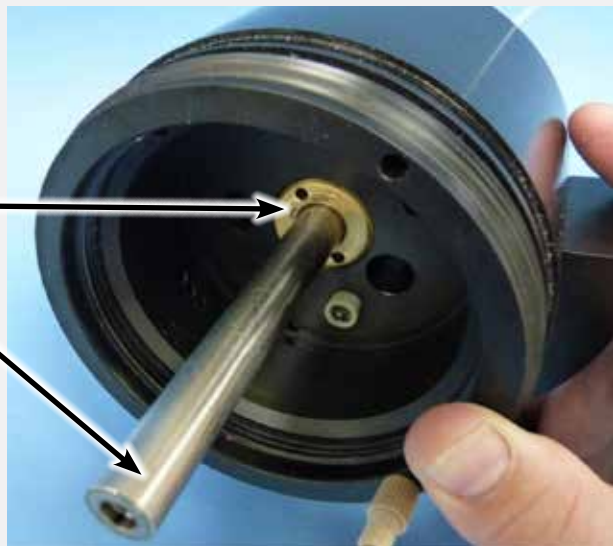

Step 22

Remove the Fluid Tube Retainer using the opposite end of the Fluid Tip/Tube Removal Tool (A11229-00).

When re-installing, tighten to 65-75 In.-Lbs. (7.64-8.42 N-m)



DISASSEMBLY PROCEDURES (65mm Bell Cup and Shape Air Ring)

Step 23

Using an Adjustable Wrench, **Note** provided with Atomizer, remove the Fiber Optic Holder.

When re-installing, tighten until unit is seated on back surface (flush).



Step 24

Slide the Fiber Optic Holder from the Atomizer Body.

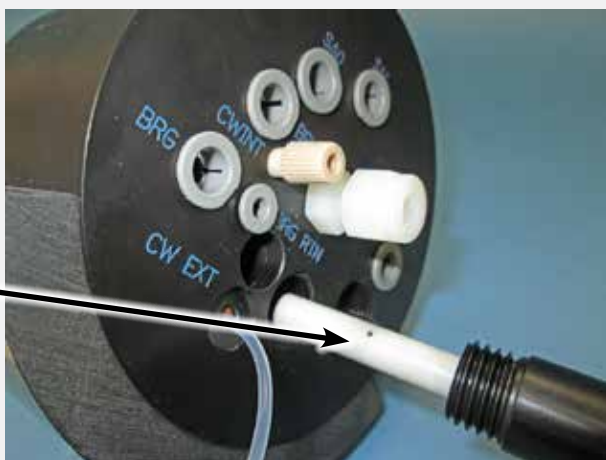

Step 25

Remove the Fiber Optic Transmitter Assembly from the Fiber Optic Holder.



DISASSEMBLY PROCEDURES (For Robot/Machine Mount Kits)

Step 1

Using A11373-00 Tubing Removal Tool push downward on the outer ring of the push-on fitting.

At the same time pull upward on the plastic tubing.

Remove all such plastic tubing from the Rear Manifold.

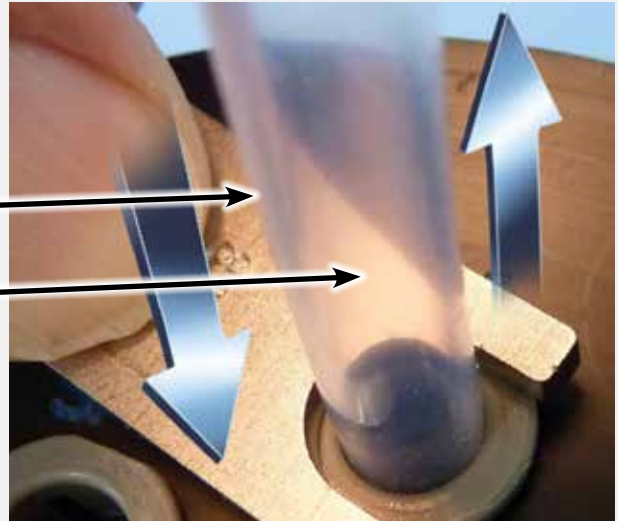

Step 2

Release the Fluid Coil (as shown) from the Rear Manifold using the Adjustable Wrench.

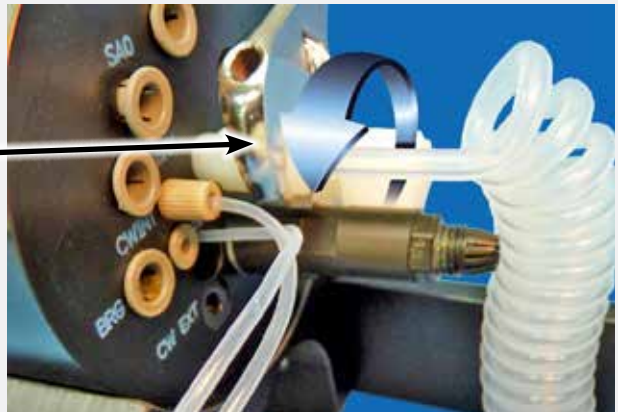

Step 3

Remove the Internal Cup Wash Fitting from the Rear Manifold.

When assembling the Internal Cup Wash Fitting, tighten with fingers until an audible “click” is heard.

Note: Be careful not to drop the Cup Wash Ferrule.

Make sure when assembling the Internal Cup Wash Fitting that the ferrule taper end is inserted into the Internal Cup Wash Fitting.

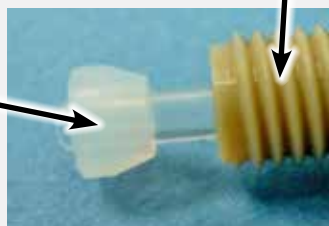

DISASSEMBLY PROCEDURES (For Robot/Machine Mount Kits)

Step 4

Remove the Cup Wash Fittings from the "Y" Fitting mounted on the Valve Manifold.

Note: Please refer to pages 62 & 63 for procedures on removal of the Cup Wash Fitting that is mounted on the Shape Air Ring with the 30 mm (65mm) Bell Cup.

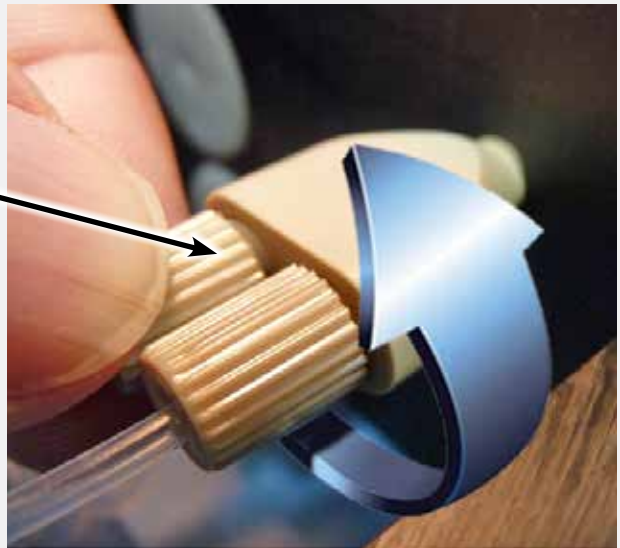

Step 5

Remove the plastic SHCS from the Mounting Manifold using the 5/16" (8mm) Hex Key Wrench .

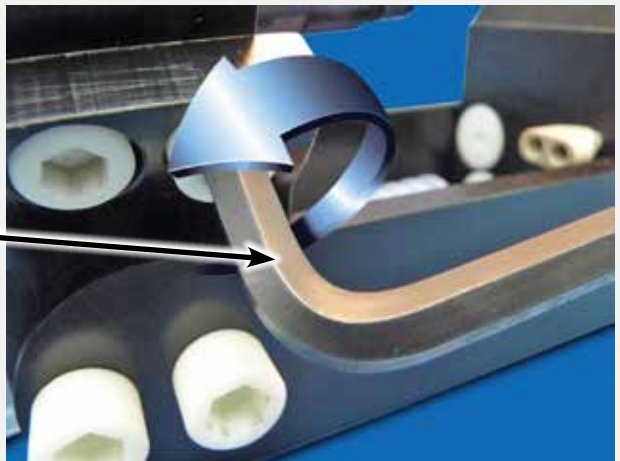

Step 6

This is how the Robot/Machine Mount should look at this point.

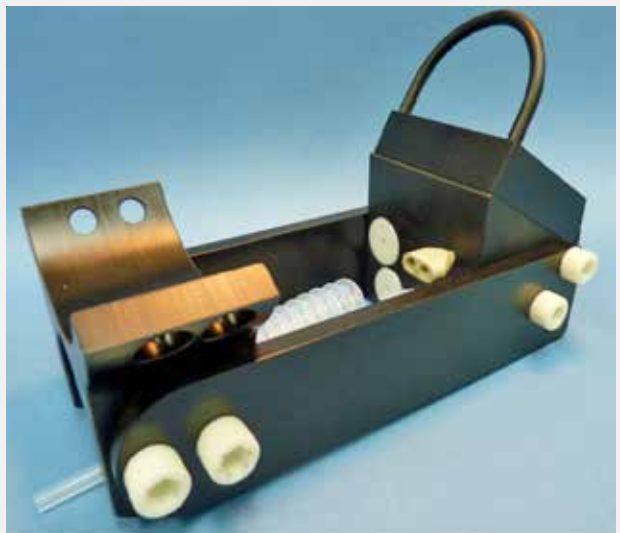

DISASSEMBLY PROCEDURES (For Robot/Machine Mount Kits)

Step 7

Remove the plastic SHCS from the Mounting Yoke using the 3/8" Hex Key Wrench .

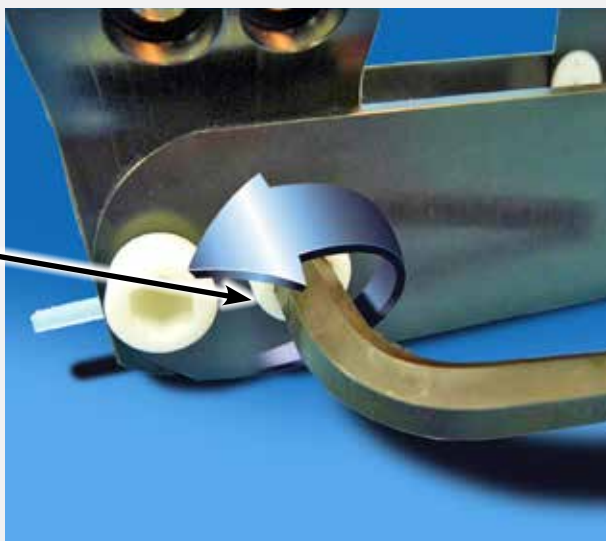

Step 8

Remove the plastic SHCS from the Valve Manifold using the 5/16" (8mm) Hex Key Wrench .

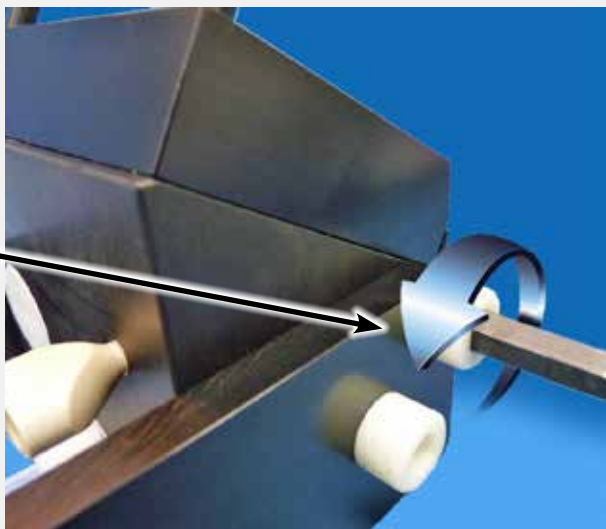

Step 9

Remove the plastic Wash Cup Y Fitting from the Valve Manifold by hand, no wrench required.



DISASSEMBLY PROCEDURES (For Robot/Machine Mount Kits)

Step 10

Remove the plastic Fluid Tube Fitting and Fluid Tube Coil from the Valve Manifold using the Adjustable Wrench.

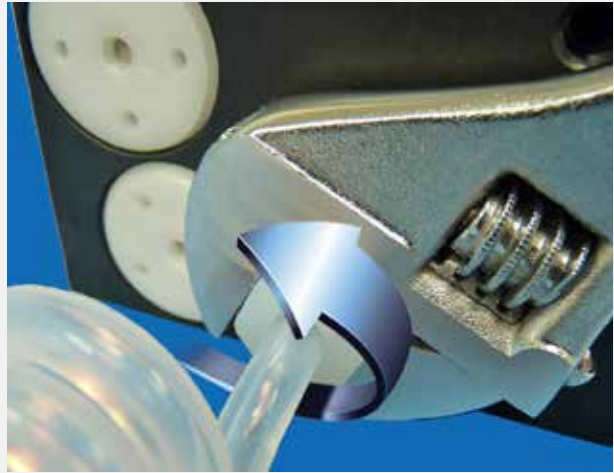

Step 11

To remove the Microvalve Assembly, use the Microvalve Removal Tool (A11922-00). Notice the small threaded shaft protruding from the tool and the four (4) locating pins.

Microvalve Assembly.

Threaded Shaft

Locating Pin

Microvalve Removal Tool A11922-00

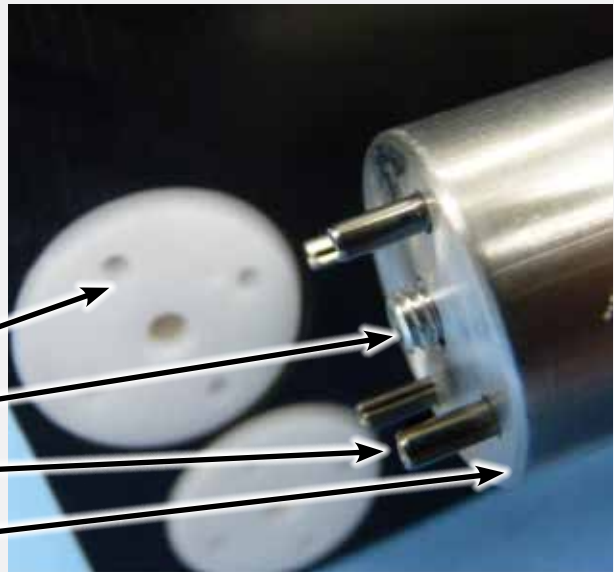

Step 12

Align and insert the four (4) locating pins on the Microvalve Removal Tool into the Microvalve Assembly four (4) holes. Secure the Microvalve Removal Tool by hand tightening the threaded shaft at the knurled end of the tool.

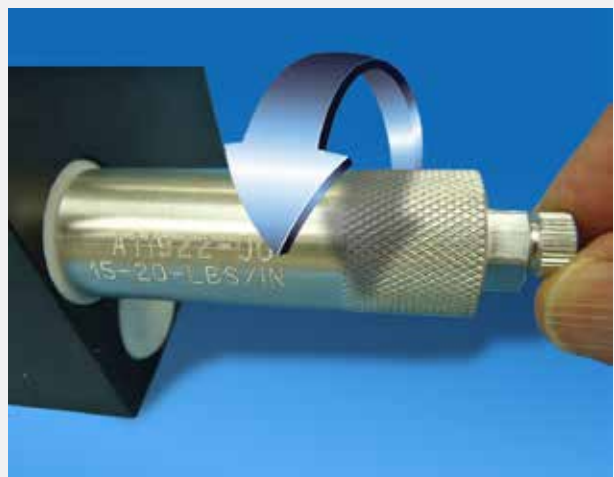

DISASSEMBLY PROCEDURES (For Robot/Machine Mount Kits)

Step 13

After securing the Microvalve Removal tool to the Microvalve Assembly loosen the Microvalve Assembly with the Adjustable Wrench.

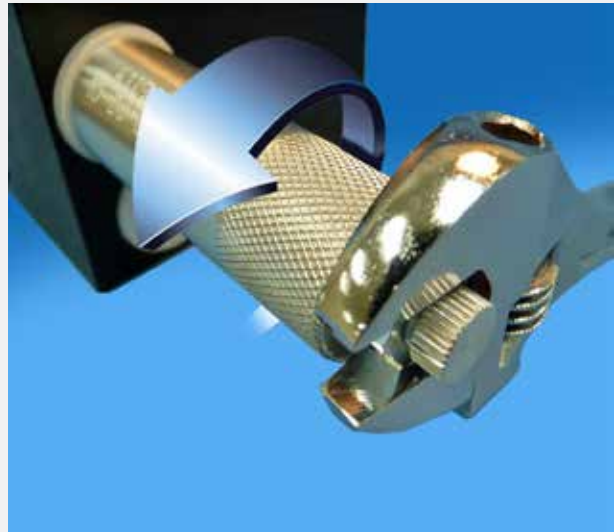

Step 14

Remove the Microvalve Assembly. When reassembling the Microvalve Assembly tighten to 15-20 In.- lbs. (1.68– 2.24 N-m)



Step 15

Using the Microvalve Seat Removal Tool (A10766-00) and the Adjustable Wrench loosen the Microvalve Seat.

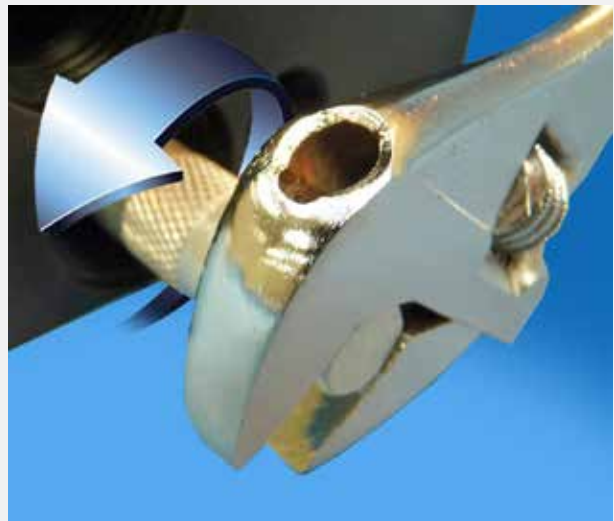

DISASSEMBLY PROCEDURES (For Robot/Machine Mount Kits)

Step 16

Remove the Microvalve Seat.

When reassembling the Microvalve Seat tighten to 15-20 In.- lbs.
(1.68– 2.24 N-m)

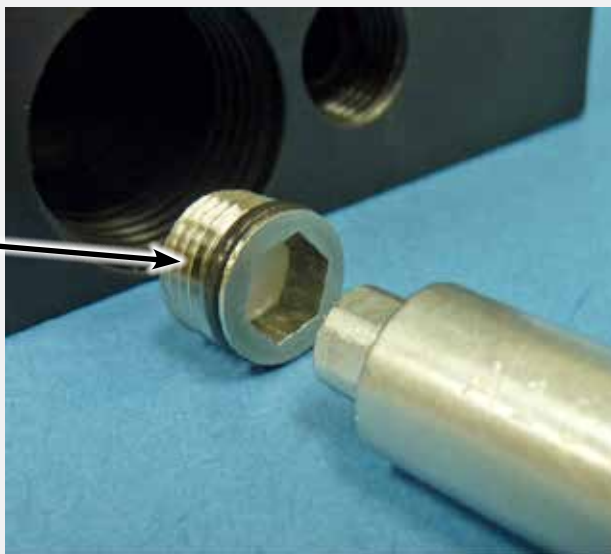

Step 17

Using the 5mm Hex Key Wrench remove the five (5) SHCS and detach the Top Valve Plate from the Valve Manifold.

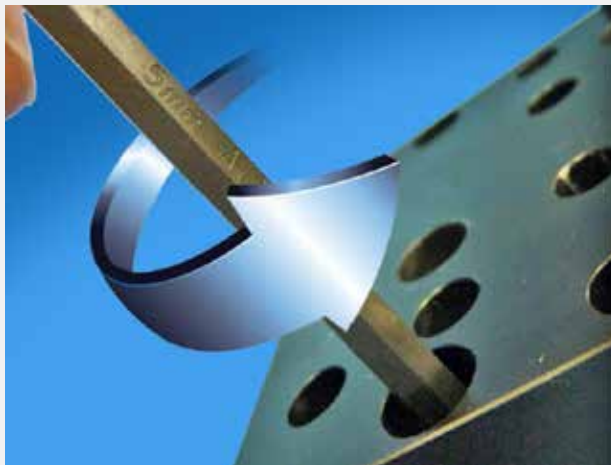

Step 18

Tighten to 10-15 In.-Lbs.
(1.23-1.68 N-m)

Five (5) SHCS

Valve Manifold

Top Valve Plate

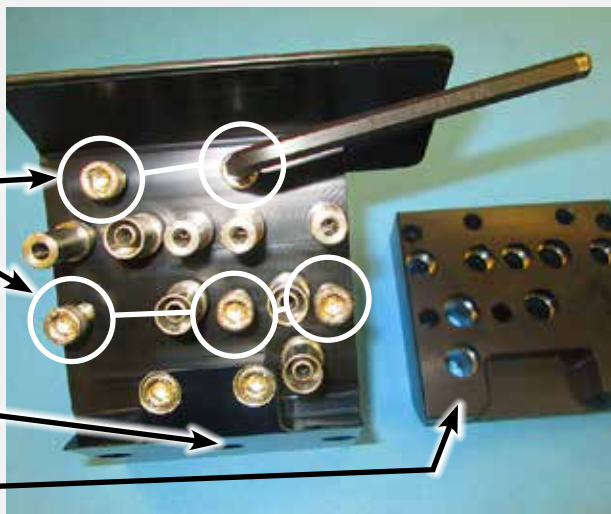

DISASSEMBLY PROCEDURES (For Robot/Machine Mount Kits)

Step 19

Using the 5mm Hex Key Wrench remove the five (5) SHCS that secure the Mounting Block to the Valve Manifold



Step 20

There are different Mounting Blocks for other applications.

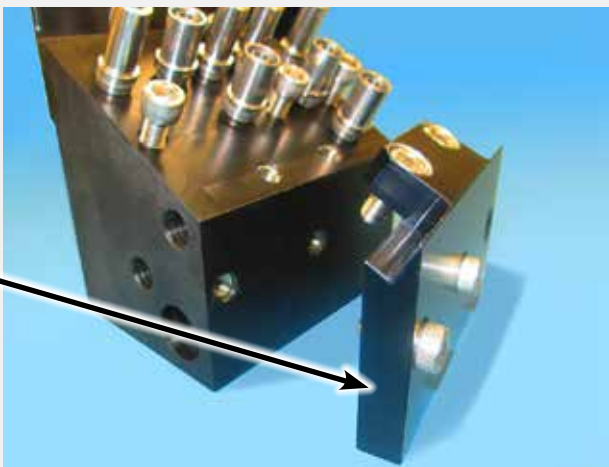

Step 21

By hand remove the four (4) A13096-00 Tube Receivers (4mm).



DISASSEMBLY PROCEDURES (For Robot/Machine Mount Kits)

Step 22

By hand remove the four (4)
A13118-00 Tube Fittings.

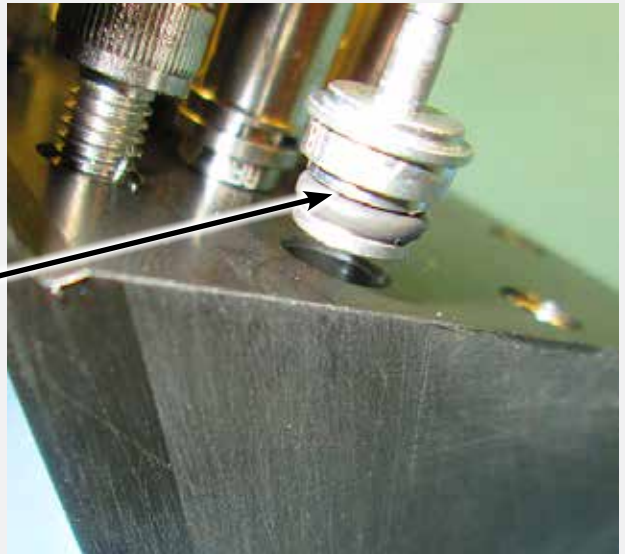

Step 23

A13096-00 Tube Receiver
A13118-00 Tube Fitting



Step 24

By hand remove the four (4)
A13288-00 receivers (8mm)

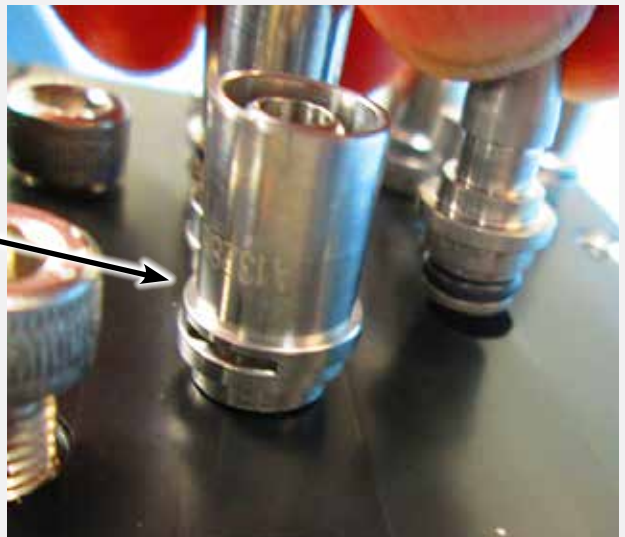

Step 25

By hand remove the four (4) A13287-00 (8mm x 6mm) or A13289-00 (8mm x 5mm) fittings

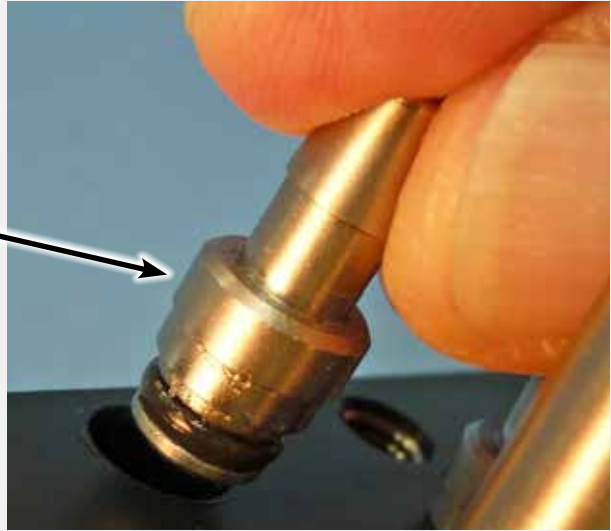

Step 26

Install the proper receiver over the tubing first

Lightly lubricate the outside diameter of the barb fitting with petroleum jelly



Step 27

Push tube fully onto barb until it stops on the fitting back shoulder



Step 28

Lightly lubricate the outside diameter of the tubing with petroleum jelly.



Step 29

Using a flat plate or surface, use an adjustable wrench to push the receiver fully over the tube and barb until it is flush with the back shoulder of the barb fitting.



Step 1 (Removal)

Insert a flat blade screwdriver into the slot on the receiver body and twist to separate the components.

Screwdriver slot

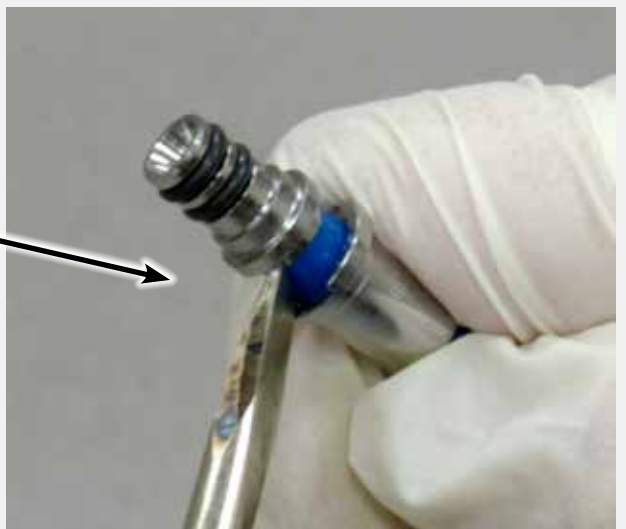

Step 2 (Repair)

Cut damaged tube away and repeat re-assembly starting at step 26



PARTS IDENTIFICATION

WHEN ORDERING USE MODEL NUMBER

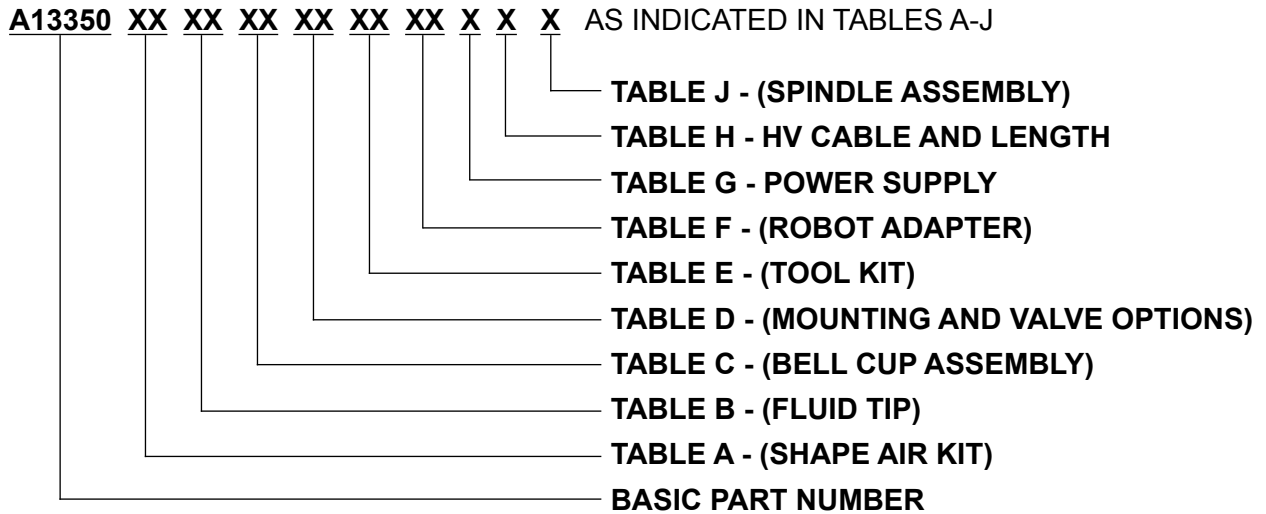

TABLE A - (SHAPE AIR KIT)		
Dash #	Part #	Description
01	A13032-01	DUAL FLEX (DUAL SHAPE AIR) - DIRECT CHARGE
02	A13032-02	MONO FLEX (SINGLE SHAPE AIR)-DIRECT CHARGE
03	A13032-03	30MM (DUAL SHAPE AIR) - DIRECT CHARGE
07	A13206-00	DUAL SHAPE AIR, 15MM, DIRECT CHARGE

11
11
11
11
11
11
11

TABLE B - (FLUID TIP)		
Dash #	Part #	Description
01	A11240-01	.028 /0.7MM
02	A11240-02	.035/ 0.9MM
03	A11240-03	.043/ 1.1MM
04	A11240-04	.047/ 1.2MM
05	A11240-05	.062/ 1.6MM
06	A11240-06	.039/ 1.0MM
07	A13601-00	.010/.025MM
08	A13625-00	.028/0.7MM STRAIGHT
09	A13625-01	.035/0.9MM STRAIGHT
10	A13625-02	.039/1.0MM STRAIGHT
11	A13625-03	.043/1.1MM STRAIGHT
12	A13625-04	.047/1.2MM STRAIGHT
13	A13625-05	.062/1.6MM STRAIGHT
14	A13625-06	.093/2.4MM STRAIGHT
15	A13625-07	.125/3.2MM STRAIGHT
16	A13625-08	.010/0.25MM STRAIGHT
17	A13645-00	.028/0.7MM INDUSTRIAL
18	A13645-01	.035/0.9MM INDUSTRIAL
19	A13645-02	.039/1.0MM INDUSTRIAL
20	A13645-03	.043/1/1MM INDUSTRIAL
21	A13645-04	.047/1.2MM INDUSTRIAL
22	A13645-05	.062/1.6MM INDUSTRIAL
23	A13645-06	.093/2.4MM INDUSTRIAL
24	A13645-07	.125/3.2MM INDUSTRIAL
25	A13645-08	.010/0.25MM INDUSTRIAL

11

TABLE C - (BELL CUP ASSEMBLY)				
Dash #	Part "B"	Description	Bell Cup Only (Ref.)	Splash Plate Only (Ref.)
01	A12942-02	65MM ALUMINUM, PLATED	A12782-00	A13644-00
02	A12833-01	30MM ALUMINUM, PLATED	A13832-00	A13274-00
03	A13207-00	15MM TITANIUM	A12936-00	-----
04	A12833-03	30MM TITANIUM	A13531-00	A13274-00
05	A13676-00	65MM TITANIUM	A13675-00	A13644-00

11 These fluid tips can only be used with these bell cups. (See table "B" and "C")

TABLE D - (MOUNTING AND VALVE OPTIONS)		
Dash #	Part #	Description
01	A13033-00	STUD MOUNT ONLY, NO VALVES, WITH REMOTE CUP WASH MANIFOLD
02	A13401-01	MACHINE MOUNT WITH TRIGGER, DUMP, CUP WASH SOLVENT VALVES WITH 79879-00 FLUID COIL (16 COILS 1/4 O.D. X 1/8 I.D.) 8 X 6 PAINT FITTING
03	A13401-02	MACHINE MOUNT WITH TRIGGER, DUMP, CUP WASH SOLVENT VALVES WITH 79879-01 FLUID COIL (12 COILS 1/4 O.D. X 1/8 I.D.) 8 X 6 PAINT FITTING
04	A13402-00	ROBOT MOUNT WITH TRIGGER, DUMP, CUP WASH SOLVENT VALVES WITH 79879-00 FLUID COIL (16 COILS 1/4 O.D. X 1/8 I.D.) 8 X 6 PAINT FITTING
05	A13402-01	ROBOT MOUNT WITH TRIGGER, DUMP, CUP WASH SOLVENT VALVES WITH 79879-01 FLUID COIL (12 COILS 1/4 O.D. X 1/8 I.D.) 8 X 6 PAINT FITTING
06	A13401-03	MACHINE MOUNT WITH TRIGGER, DUMP, CUP WASH SOLVENT VALVES WITH 79879-00 FLUID COIL (16 COILS 1/4 O.D. X 1/8 I.D.) 8 X 5 PAINT FITTING
07	A13401-04	MACHINE MOUNT WITH TRIGGER, DUMP, CUP WASH SOLVENT VALVES WITH 79879-01 FLUID COIL (12 COILS 1/4 O.D. X 1/8 I.D.) 8 X 5 PAINT FITTING
08	A13402-03	ROBOT MOUNT WITH TRIGGER, DUMP, CUP WASH SOLVENT VALVES WITH 79879-00 FLUID COIL (16 COILS 1/4 O.D. X 1/8 I.D.) 8 X 5 PAINT FITTING
09	A13402-04	ROBOT MOUNT WITH TRIGGER, DUMP, CUP WASH SOLVENT VALVES WITH 79879-01 FLUID COIL (12 COILS 1/4 O.D. X 1/8 I.D.) 8 X 5 PAINT FITTING

TABLE E - (TOOL KIT)			
Dash #	Part #	Tool Kit Includes	Description
01	---	---	NO TOOL KIT
02	A13082-01	RPM-419, A12899-00, A11229-00, A12088-00, A11388-00, 59972-00	POST MOUNT APPLICATOR WITH 30MM OR 65MM BELL CUP
03	A13082-02	RPM-419, A12899-00, A11229-00, A12088-00, A11388-00, A11922-00, A10766-00, 59972-00	APPLICATOR WITH 30MM OR 65MM BELL CUP WITH VALVE PACKAGE
04	A13082-03	RPM-419, A11229-00, A12088-00, A12939-00, 59972-00	POST MOUNT APPLICATOR WITH 15MM
05	A13082-04	RPM-419, A11229-00, A12088-00, A12939-00, A11922-00, A10766-00, 59972-00	APPLICATOR WITH 15MM BELL CUP WITH VALVE PACKAGE

TABLE F - ROBOT ADAPTER & MTG. SCREWS				
Dash #	Part #	Description	Part #	Description
01	NONE	NONE		
02	A13031-00	FANUC PAINT MATE	79798-00	SHCS M5 x 12MM LONG

TABLE G - (POWER SUPPLY)			
Dash #	Description	Qty. "N"	Part #
-0	NO POWER SUPPLY	0	---
-1	DOMESTIC 10" RACK	1	80120-511
-2	EUROPE 10" RACK	1	80120-512
-3	CHINA 10" RACK	1	80120-513
-4	DOMESTIC BOX STYLE	1	80100-511
-5	EUROPE BOX STYLE	1	80100-512
-6	CHINA BOX STYLE	1	80100-513

TABLE H - (HIGH VOLTAGE CABLE)		
Dash #	Description	Part #
-0	NO CABLE	---
-1	HIGH VOLTAGE CABLE -15' (4.6m) (SHIELDED)	A13386-15
-2	HIGH VOLTAGE CABLE -25' (7.6m) (SHIELDED)	A13386-25
-3	HIGH VOLTAGE CABLE -50' (15.2m) (SHIELDED)	A13386-50
-4	HIGH VOLTAGE CABLE -15' (4.6m)	A13348-15
-5	HIGH VOLTAGE CABLE -25' (7.6m)	A13348-25
-6	HIGH VOLTAGE CABLE -50' (15.2m)	A13348-50

TABLE J - (SPINDLE ASSEMBLY)		
Dash #	Part "P"	Description
-0	NONE	NONE
-1	A12777-00	SILVER SHAFT STYLE
-2	A12777-02	BLACK SHAFT STYLE

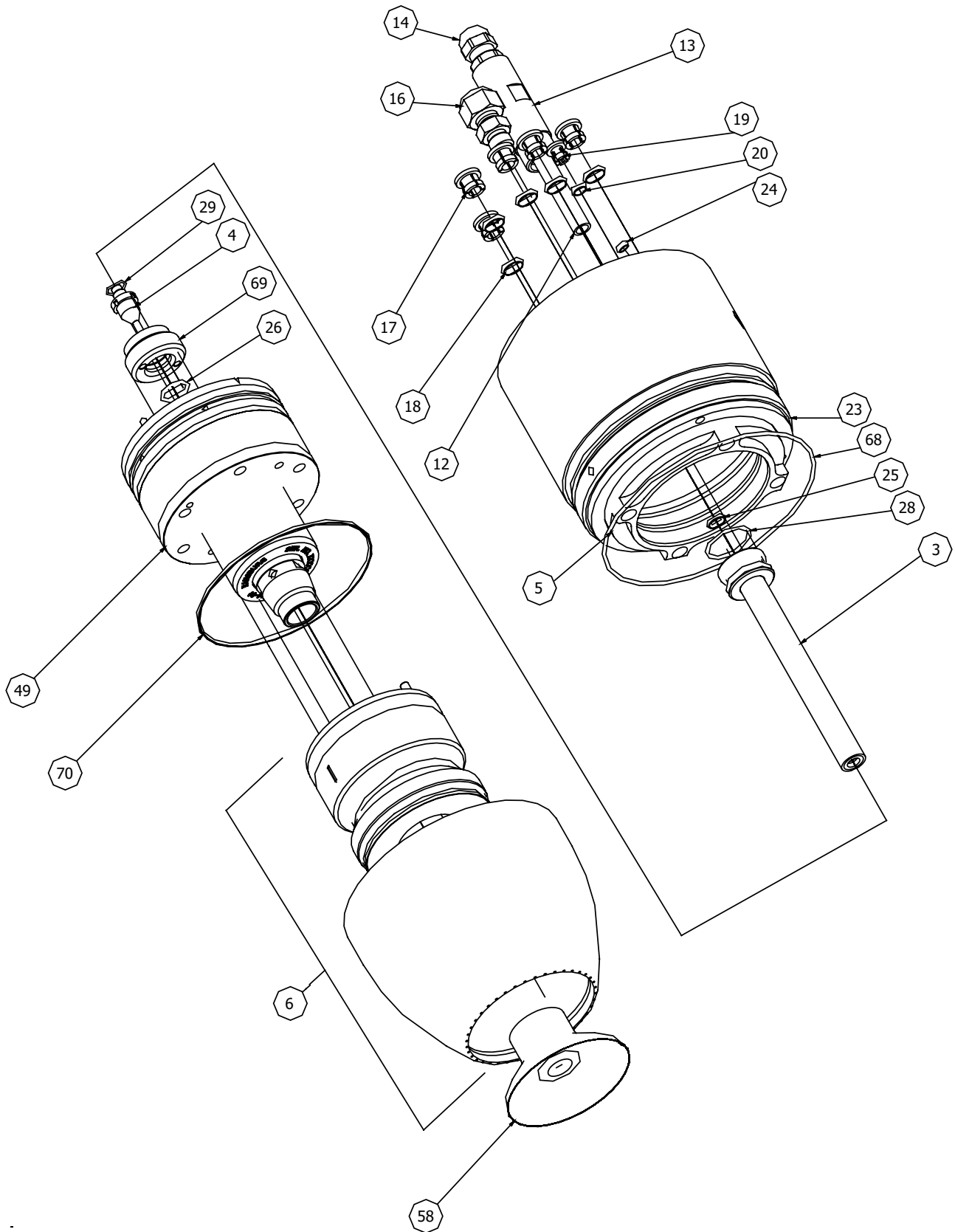

Applicator Parts Breakdown

APPLICATOR PARTS BREAKDOWN			
Item #	Part #	Description	Qty
3	A12796-00	ASS'Y, FLUID TUBE	1
11	4	TABLE B FLUID TIP	1
5	A12781-00	TURBINE RETAINING RING	1
6	TABLE A	SHAPE AIR KIT	1
9	A11226-00	FLUID TUBE RETAINER	1
12	77591-00	TRANSMITTER ASSEMBLY, INDUCTOR TO FIBER OPTIC	1
13	A12810-00	FIBER OPTIC HOLDER	1
14	20869-14	CONNECTOR, LIQUID TIGHT	1
16	LSFI0022-04	FITTING, 1/4 ODT X AN	1
17	77762-04	COLLET, 8 MM	5
18	79001-34	O-RING, SOLVENT PROOF	5
19	77516-04	COLLET, 4 MM	1
20	79001-30	O-RING, SOLVENT PROOF	1
23	A12941-01	MOUNTING MANIFOLD	1
24	7554-127	O-RING	1
25	79001-40	O-RING, SOLVENT PROOF	1
26	79001-42	O-RING, SOLVENT PROOF	1
28	79001-41	O-RING, SOLVENT PROOF	1
29	79001-44	O-RING, SOLVENT PROOF	1
49	TABLE J, ITEM P	SPINDLE ASSEMBLY	1
11	58	TABLE C BELL CUP ASSEMBLY	1
59	TABLE D	MOUNTING STYLE OPTION	1
60	TABLE E, ITEM G	TOOL KIT	TABLE E
68	79001-22	O-RING	1
69	TABLE F	ROBOT ADAPTER	1
70	79001-11	O-RING	1
71	77141-25	LITERATURE KIT	1
72	A13382-00	RESISTOR ASSEMBLY (NOT SHOWN)	1
73	A13698-00	PLUG, FIBER OPTIC, EXHAUST	2

11 These fluid tips can only be used with these bell cups. (See table "B" and "C")

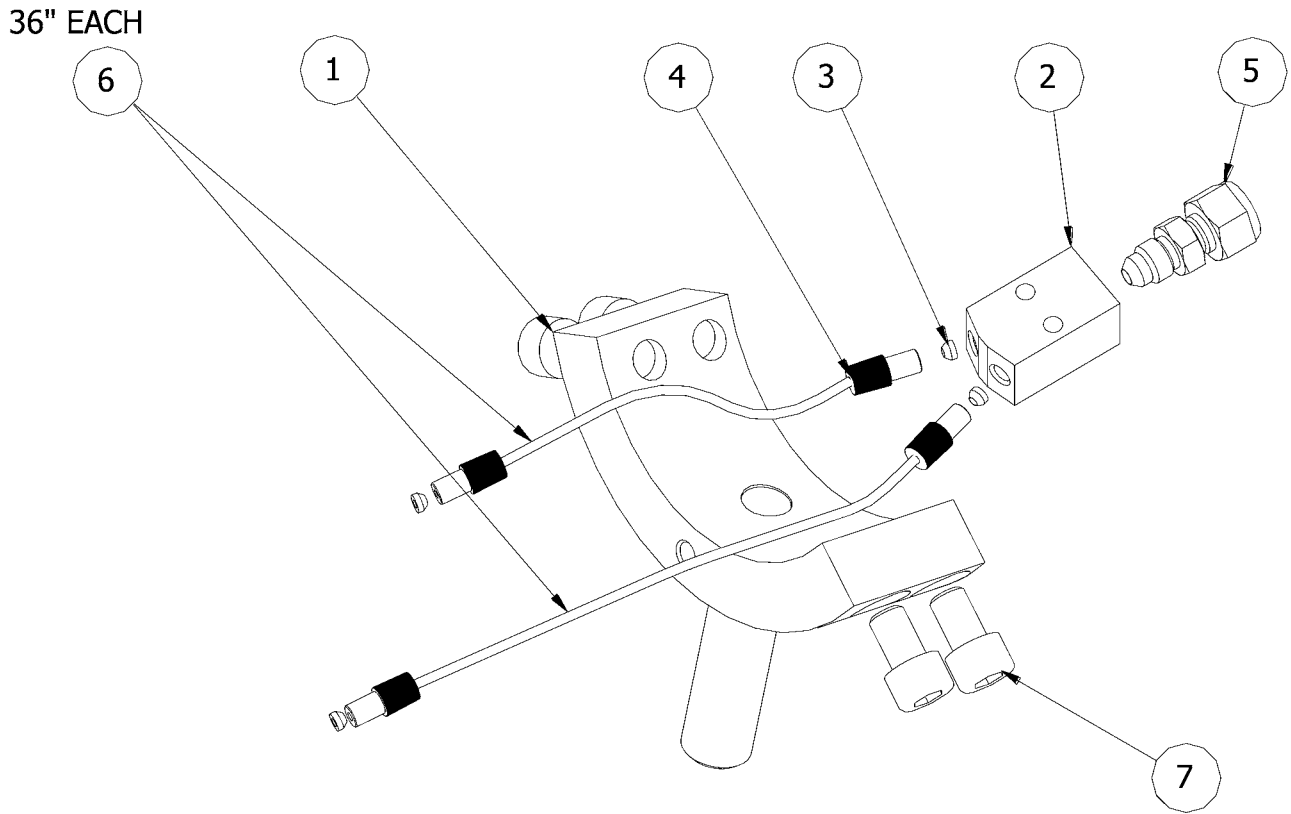

A13033 Stud Mount Assembly

STUD MOUNT ASSEMBLY			
Item #	Part #	Description	Qty
2	A12913-00	CUP WASH Y FITTING	1
3	A12822-00	CUP WASH FERRULE	4
4	A12821-00	CUP WASH FITTING	4
5	LSFI0022-04	FITTING, 1/4 O.D. X AN	1
6	A11252-01	PFA (3/32 O.D. X 1/16 I.D.) (2 PIECES- 3 FT. EACH)	6'
7	A12807-00	SCREW (M10 X 16MM LONG)	4
9	A13668-00	POST MOUNT ASSEMBLY	1

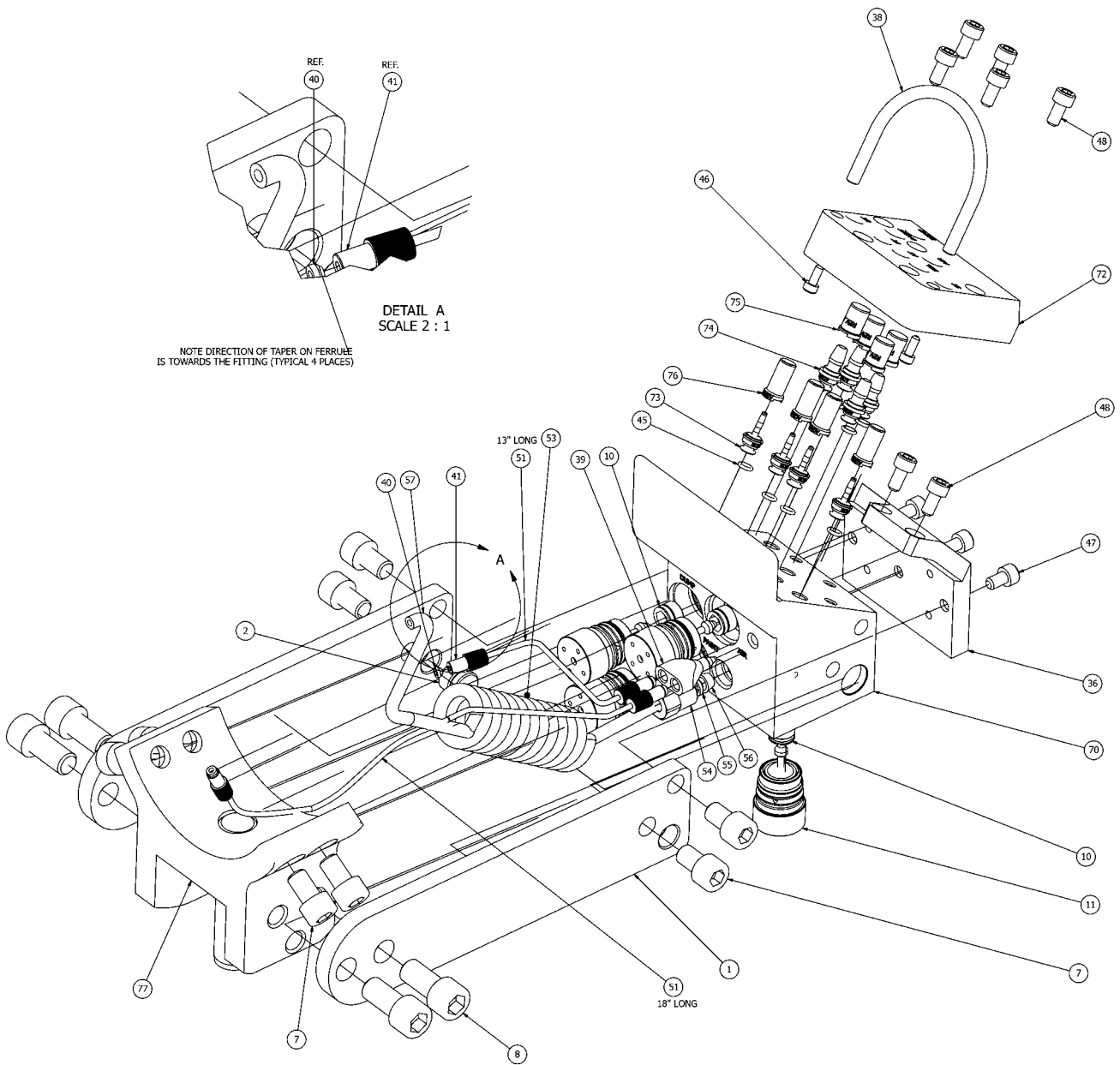

A13401 Machine Mount Kit (with Valves)

MACHINE MOUNT KIT - PARTS LIST (A13401)			
Item #	Qty	Part #	Description
	2	A12789-01	BRACKET ARM
	2	A12793-00	BRACKET PIVOT
3	8	A12807-00	SCREW (M10 X 16MM LONG)
3	4	A12808-00	SCREW (M12 X 25MM LONG)
2	4	77367-00	VALVE SEAT ASSEMBLY
1	4	78949-00	VALVE ASSEMBLY (NON-REPAIRABLE)
	1	A12912-00	MOUNTING BLOCK
	1	A12825-00	TUBING GUIDE
	1	A12824-00	CUP WASH Y FITTING
	4	A12822-00	CUP WASH FERRULE
4	4	A12821-00	CUP WASH FITTING
	8	79001-04	O-RING, SOLVENT PROOF
3	2	A11119-10	SCREW, SHCS M4 X 10MM LONG SS
3	3	A10468-10	SCREW, SHCS, M6 X 1.0 X 10MM, SS
3	7	A10468-12	SCREW, SHCS, M6 X 1.0 X 12MM, SS
	31"	A11252-01	PFA TUBING
	1	TABLE A PART A	COILED FLUID TUBE
	1	78449-00	FITTING, FLUID
	1	EMF-202-04	FERRULE, BACK 1/4" TUBE
	1	EMF-203-04	FERRULE, FRONT 1/4" TUBE
	1	A13693-00	VALVE MANIFOLD (4 VALVES)
	1	A13694-00	TOP VALVE PLATE
3	4	TABLE A PART B	BARB FITTING
	4	TABLE A PART C	RECEIVER
	4	A13096-00	TUBE RECEIVER (4 X 2.7)
	4	A13118-00	FITTING (4MM X 2.7MM WITH FLANGE)
	1	A13706-00	MOUNTING YOKE ASSEMBLY

- 4 > FINGER TIGHT UNTIL CLICK
- 3 > TORQUE TO 5-10 LBS. - IN. (.56-1.13 Nm)
- 2 > TORQUE TO 15-20 LBS. - IN. (1.69 - 2.26 Nm)
- 1 > TORQUE TO 15-20 LBS. - IN. (1.69 - 2.26 Nm) AFTER VALVE IS DOWN

TABLE A - MACHINE MOUNT KIT OPTIONS WITH FLUID TUBE				
Part #	Part A (Coil)	Part B (Paint Fitting)	Part C (Receiver)	Description
A13401-01	79879-00	A13287-00 (FOR 8 X 6 TUBING)	A13288-00	MACHINE MOUNT WITH TRIGGER, DUMP, CUP WASH SOLVENT VALVES & FLUID COIL (16 COILS) 1/4 O.D. X 1/8 I.D.
A13401-02	79879-01	A13287-00 (FOR 8 X 6 TUBING)	A13288-00	MACHINE MOUNT WITH TRIGGER, DUMP, CUP WASH SOLVENT VALVES & FLUID COIL (12 COILS) 1/4 O.D. X 1/8 I.D.
A13401-03	79879-00	A13289-00 (FOR 8 X 5 TUBING)	A13293-00	MACHINE MOUNT WITH RIGGER, DUMP, CUP WASH SOLVENT VALVES & FLUID COIL (16 COILS) 1/4 O.D. X 1/8 I.D.
A13401-04	79879-01	A13289-00 (FOR 8 X 5 TUBING)	A13293-00	MACHINE MOUNT WITH TRIGGER, DUMP, CUP WASH SOLVENT VALVES & FLUID COIL (12 COILS) 1/4 O.D. X 1/8 I.D.

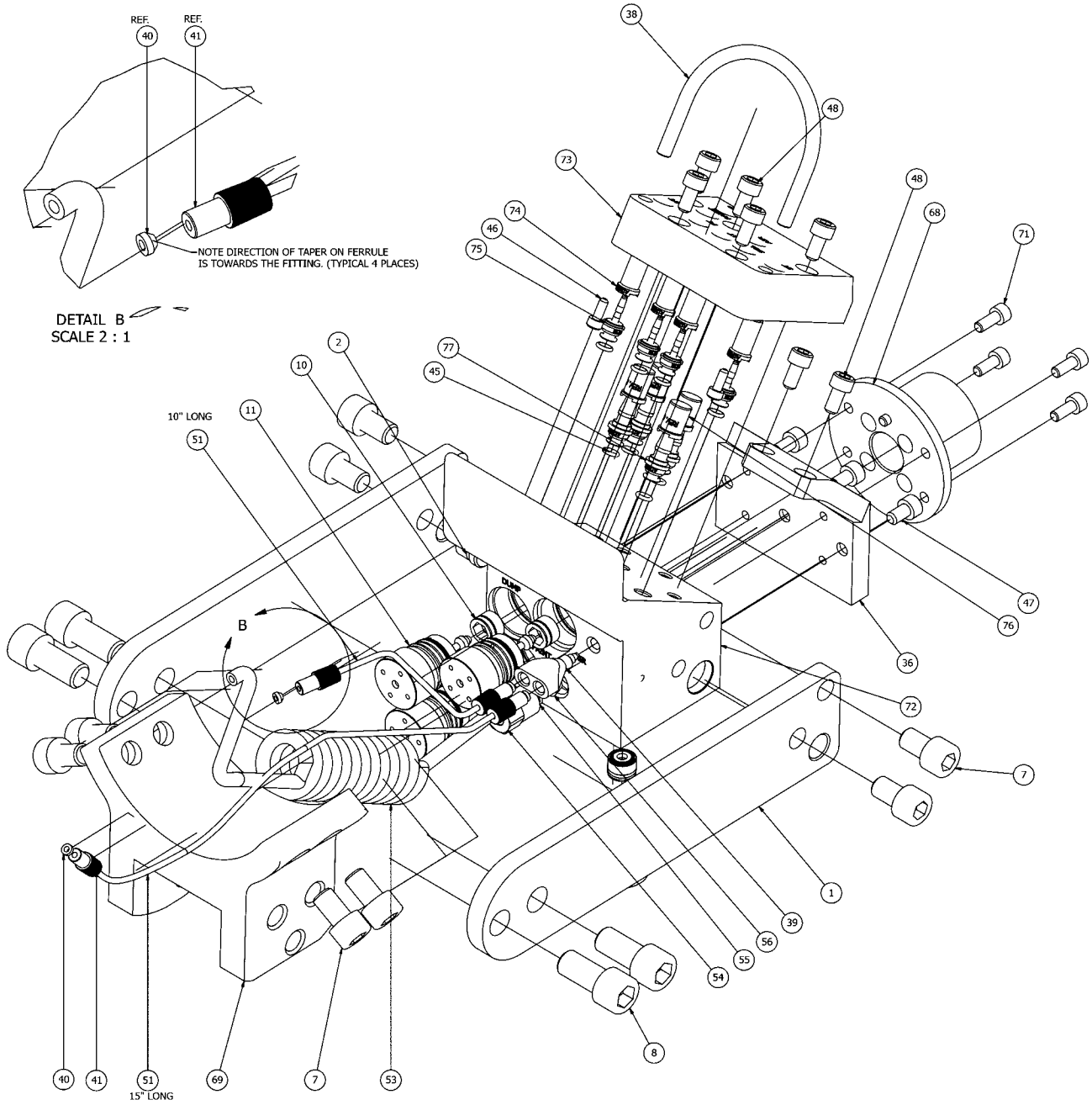

A13402 Robot Mount Kit (With Valves)

ROBOT MOUNT KIT (A13402)			
Item #	Qty	Part #	Description
1	2	A12789-01	BRACKET ARM
2	2	A12793-00	BRACKET PIVOT
3 7	8	A12807-00	SCREW (M10 X 16MM LONG)
3 8	4	A12808-00	SCREW (M12 X 25MM LONG)
2 10	4	77367-00	VALVE SEAT ASSEMBLY
1 11	4	78949-00	VALVE ASSEMBLY (NON-REPAIRABLE)
36	1	A12912-00	MOUNTING BLOCK
38	1	A12825-00	TUBING GUIDE
39	1	A12824-00	CUP WASH Y FITTING
4 40	4	A12822-00	CUP WASH FERRULE
3 41	4	A12821-00	CUP WASH FITTING
3 45	8	79001-04	O-RING, SOLVENT PROOF
3 46	2	A11119-10	SCREW, SHCS M4 X 10MM LONG SS
47	3	A10468-10	SCREW, SHCS, M6 X 1.0 X 10MM, SS
48	7	A10468-12	SCREW, SHCS, M6 X 1.0 X 12MM, SS
51	31"	A11252-01	PFA TUBING
53	1	TABLE A PART A	COILED FLUID TUBE
54	1	78449-00	FITTING, FLUID
55	1	EMF-202-04	FERRULE, BACK 1/4" TUBE
3 56	1	EMF-203-04	FERRULE, FRONT 1/4" TUBE
68	REF	REFERENCE PRINT A13350	ADAPTER, ROBOT
69	1	A12976-00	MOUNTING YOKE
71	REF	REFERENCE PRINT A13350	SHCS M5 x 12MM LONG SS
72	1	A13693-00	VALVE MANIFOLD (4 VALVES)
73	1	A13694-00	TOP VALVE PLATE
74	4	A13118-00	FITTING (4MM X 2.7MM WITH FLANGE)
75	4	A13096-00	TUBE RECEIVER (4 X 2.7)
76	4	TABLE A PART B	BARB FITTING
77	4	TABLE A PART C	RECEIVER

- 4 > FINGER TIGHT UNTIL CLICK
- 3 > TORQUE TO 5-10 LBS. - IN. (.56-1.13 Nm)
- 2 > TORQUE TO 15-20 LBS. - IN. (1.69 - 2.26 Nm)
- 1 > TORQUE TO 15-20 LBS. - IN. (1.69 - 2.26 Nm) AFTER VALVE IS DOWN

TABE A - MACHINE MOUNT KIT OPTIONS WITH FLUID TUBE

Part #	Part A (Fluid Coil)	Part B (Paint Fitting)	Part C (Receiver)	Description
A13402-00	79879-00	A13318-00 (FOR 8 X 6 TUBING)	A13288-00	ROBOT MACHINE MOUNT WITH TRIGGER, DUMP, CUP WASH SOLVENT VALVES WITH FLUID COIL-16 COILS (1/4 O.D. X 1/8 I.D.)
A13402-01	79879-01	A13318-00 (FOR 8 X 6 TUBING)	A13288-00	ROBOT MACHINE MOUNT WITH TRIGGER, DUMP, CUP WASH SOLVENT VALVES WITH FLUID COIL- 12 COILS (1/4 O.D. X 1/8 I.D.)
A13402-03	79879-00	A13319-00 (FOR 8 X 5 TUBING)	A13293-00	ROBOT MACHINE MOUNT WITH TRIGGER, DUMP, CUP WASH SOLVENT VALVES WITH FLUID COIL- 16 COILS (1/4 O.D. X 1/8 I.D.)
A13402-04	79879-01	A13319-00 (FOR 8 X 5 TUBING)	A13293-00	ROBOT MACHINE MOUNT WITH TRIGGER, DUMP, CUP WASH SOLVENT VALVES WITH FLUID COIL- 12 COILS (1/4 O.D. X 1/8 I.D.)

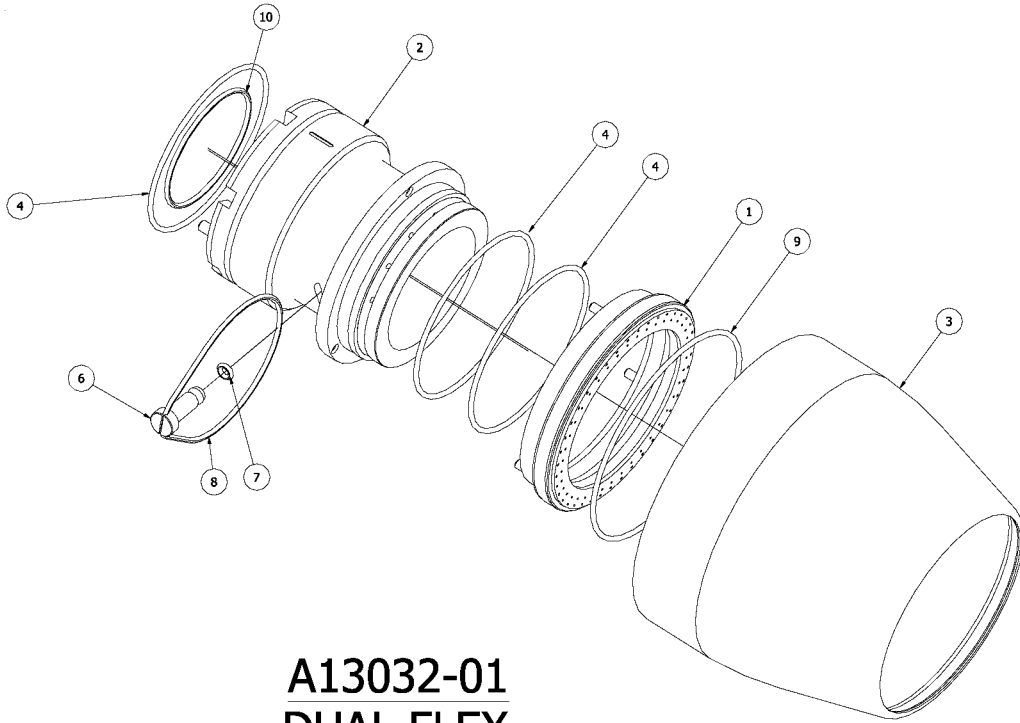

A13032-01
DUAL FLEX
DIRECT CHG.

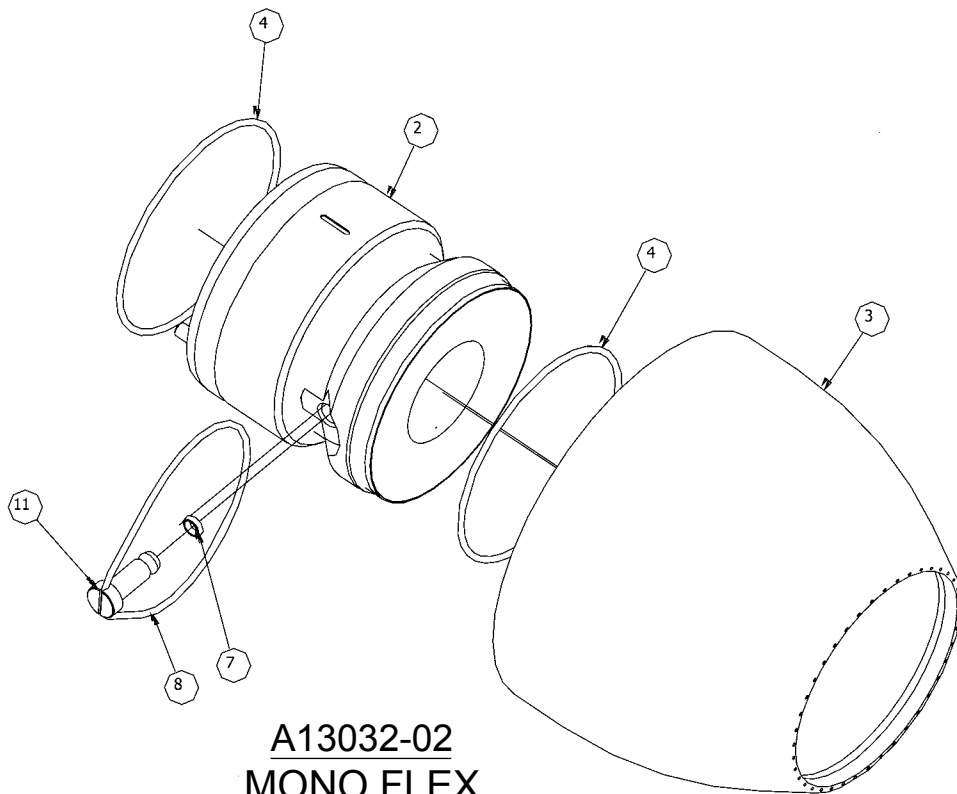

A13032-02
MONO FLEX
DIRECT CHG

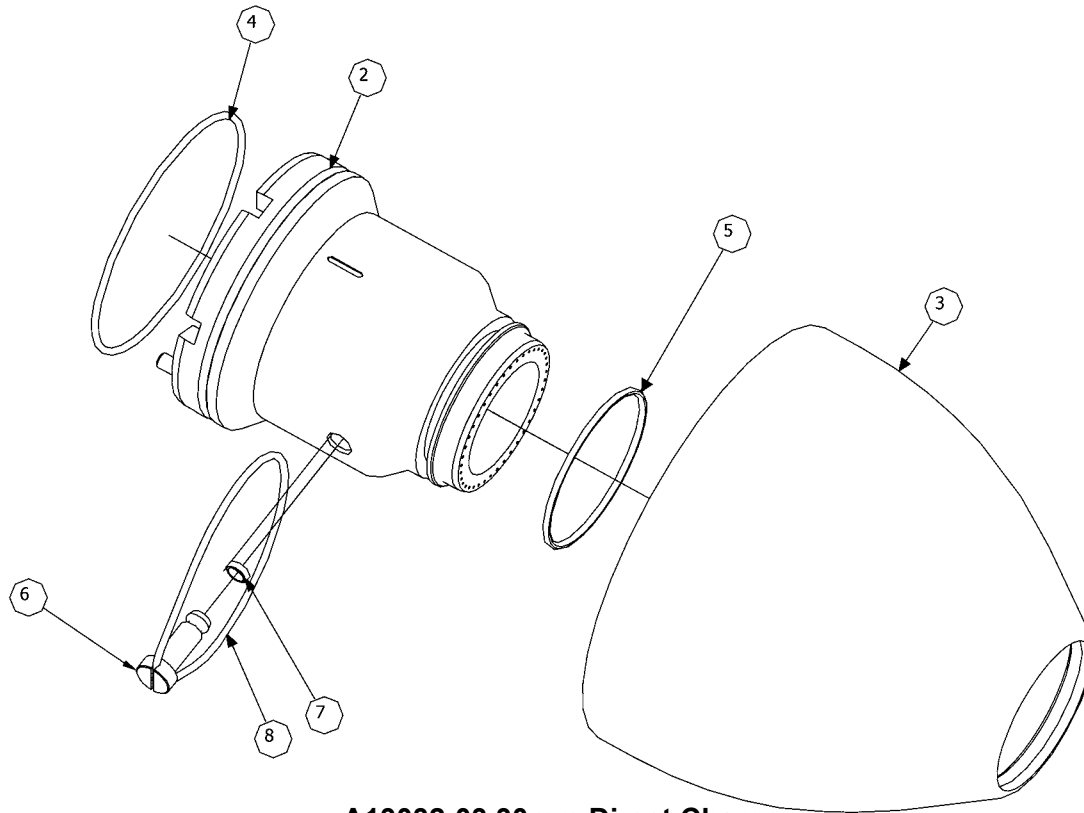

A13032-03 30mm Direct Charge

MASTER CONFIGURATION TABLE								
PART #	DESCRIPTION	A	B	C	D	E	F	G
		SHP AIR RING	SHAP AIR MANIFOLD	SHROUD				
A13032-01	65MM DUAL FLEX SHP AIR KIT - DIRECT CHG.	A12911-00	A12910-00	A12909-00	3		1	1
A13032-02	65MM MONO FLEX SHP AIR KIT - DIRECT CHG.		A12896-00	A12779-01	2			
A13032-03	30MM - DIRECT CHG.		A12831-00	A12830-00	1	1		

A13032-03 30MM SHAPE AIR			
Item #	Part #	Description	Qty
1	A	SHAPE AIR RING	1
2	B	SHAPE AIR MANIFOLD	1
3	C	SHROUD	1
4	79001-10	O-RING, SOLVENT PROOF	D
5	79001-52	O-RING, SOLVENT PROOF	E
6	A12898-00	SHAPE AIR PLUG	1
7	79001-16	O-RING, SOLVENT PROOF	1
8	7554-72	O-RING	1
9	79001-11	O-RING, SOLVENT PROOF	F
10	79001-35	O-RING, SOLVENT PROOF	G

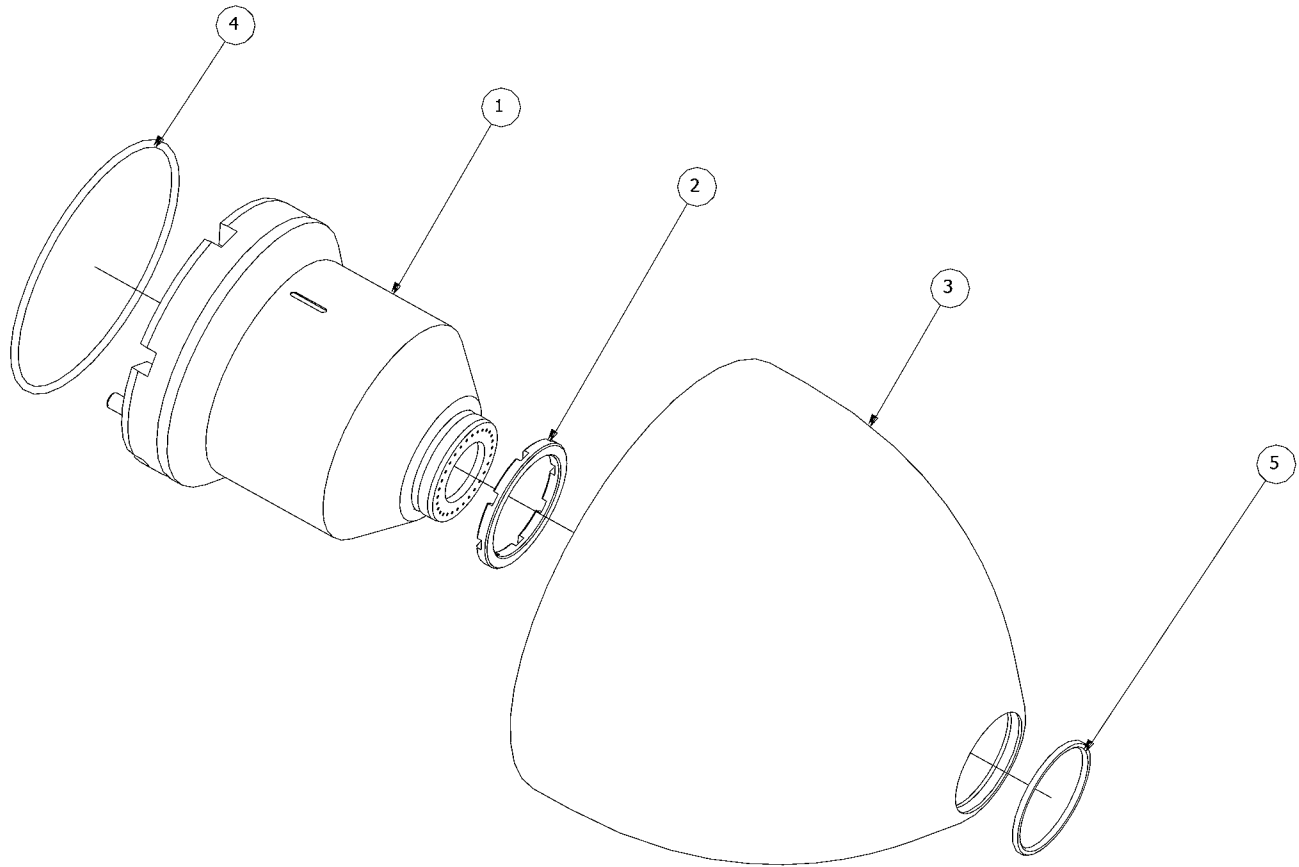

A15206-00 15mm Direct Charge

A13206-00 15MM SHAPE AIR			
Item #	Part #	Description	Qty
1	A12935-00	INNER SHAPE AIR RING	1
2	A12934-00	SPACER	1
3	A12933-00	SHROUD, 15MM	1
4	79001-10	O-RING, SOLVENT PROOF	1
5	79001-57	O-RING, SOLVENT PROOF	1

FIBER OPTIC CABLE LENGTH	
Part #	Description
N/A	Fiber Optic Cable (Not Included)
A12409-01	3 Ft. (0.9m) Long Fiber Optic Cable
A12409-02	6 Ft. (1.8m) Long Fiber Optic Cable
A12409-03	10 Ft. (3.0m) Long Fiber Optic Cable
A12409-04	15 Ft. (4.6m) Long Fiber Optic Cable
A12409-05	25 Ft. (7.6m) Long Fiber Optic Cable
A12409-06	40 Ft. (12.2m) Long Fiber Optic Cable
A12409-07	50 Ft. (15.2m) Long Fiber Optic Cable
A12409-08	65 Ft. (19.8m) Long Fiber Optic Cable
A12409-08	75 Ft. (22.9m) Long Fiber Optic Cable
A12409-10	100 Ft. (30.5m) Long Fiber Optic Cable

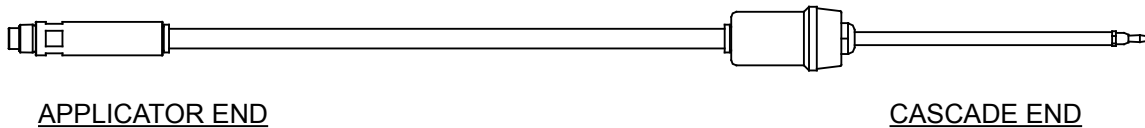

HIGH VOLTAGE CABLES (SHIELDED)	
Part #	Description
A13386-15	15 Ft. (4.6m) High Voltage Cable Assy. Shield, Non-Metallic Center Conductor
A13386-25	25 Ft. (7.6m) High Voltage Cable Assy. Shield, Non-Metallic Center Conductor
A13386-50	50 Ft. (15.2m) High Voltage Cable Assy. Shield, Non-Metallic Center Conductor

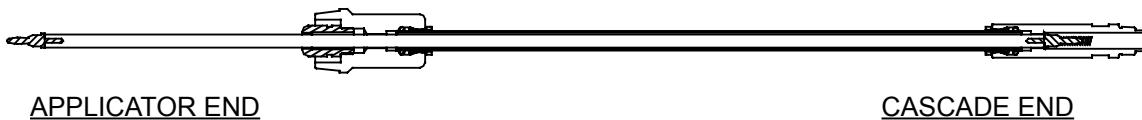

HIGH VOLTAGE CABLES (NON-SHIELDED)	
Part #	Description
A13348-15	15 Ft. (4.6m) High Voltage Cable Assembly
A13348-25	25 Ft. (7.6m) High Voltage Cable Assembly
A13348-50	50 Ft. (15.2m) High Voltage Cable Assembly

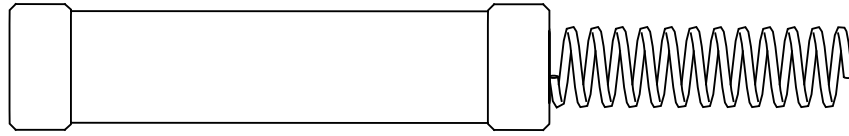

HIGH VOLTAGE RESISTOR ASSEMBLY	
Part #	Description
A13382-00	Assembly, Resistor

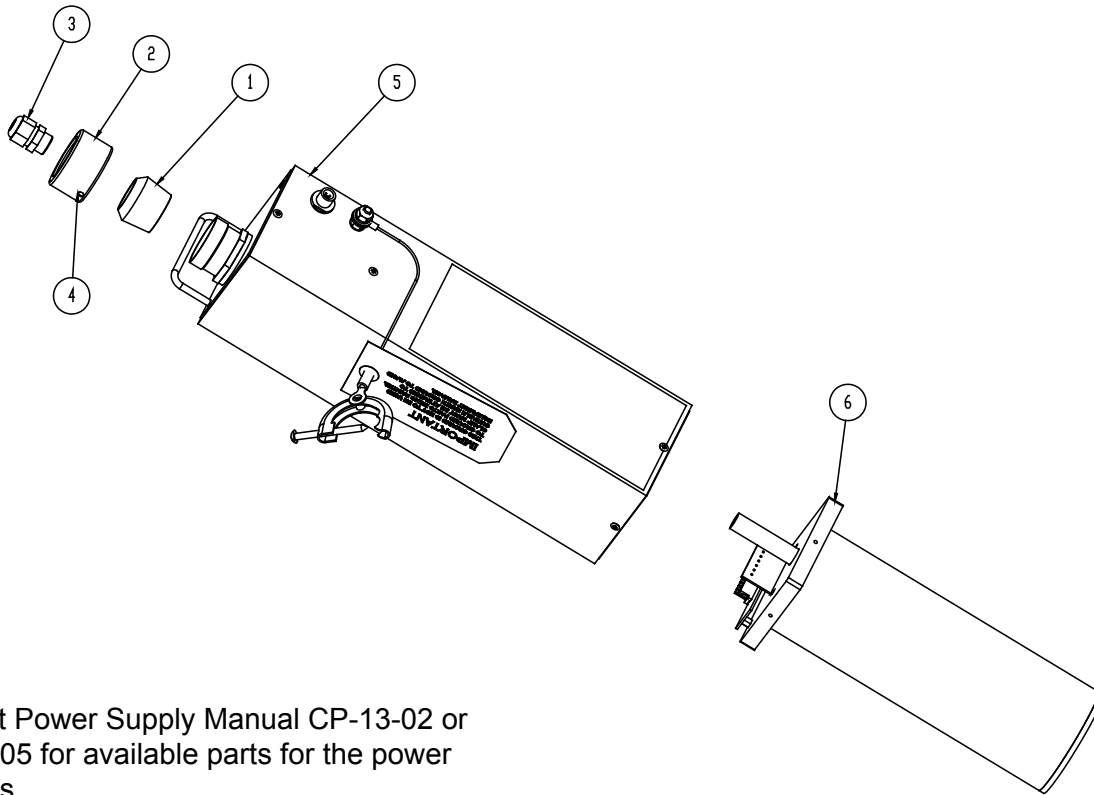

Consult Power Supply Manual CP-13-02 or CP-13-05 for available parts for the power supplies.

80104-01 EXTERNAL CASCADE COMPONENTS		
Item #	Part #	Description
1*	80074-00	COUPLIER, CABLE
2*	7296-00	NUT, CABLE PLUG
3*	80073-00	RELIEF, STRAIN
4*	8521-06F	SET SCREW
5	80104-01	ASSEMBLY, EXTERNAL
6	79350-01	ASSEMBLY, CASCADE

* Not included with the 80104-01 Assembly but with the A13386-XX Assembly.

ACCESSORIES, LUBRICANTS	
Part #	Description
59972-00	Dielectric Grease
76652-01	Kit for measuring high voltage. Includes Multi-Function Meter (76634-00) and High Voltage Probe Assy. (76667-00).
76652-02	Kit for measuring short circuit current (SCI), resistance, and spray ability. Includes Multi-Function Meter (76634-00) and Test Lead Assy. (76664-00).
76652-03	Kit for measuring paint resistivity. Includes Multi-Function Meter (76634-00) and Paint Probe Assy. (7922-00)
76652-04	Deluxe Kit (performs all functions listed above). Includes Multi-Function Meter (76634-00), Paint Probe Assy. (7922-00), Test Lead Assy. (76664-00), and High Voltage Probe Assy. (76667-00)
A11545-00	Petrolatum Jell Lubricant for all O-Rings

SERVICE KITS	
Part #	Description
RPM-32	Pre-Filter Replacement Element
RPM-33	Bearing Air Filter Element
A11570-01	Reducing Straight Connector, Push to Connect, 6mm OD to 4mm OD Tube
A11570-02	Reducing Straight Connector, Push to Connect, 8mm OD to 4mm OD Tube
A11570-03	Reducing Straight Connector, Push to Connect, 8mm OD to 6mm OD Tube
A11570-04	Reducing Straight Connector, Push to Connect, 10mm OD to 4mm OD Tube
A11570-05	Reducing Straight Connector, Push to Connect, 10mm OD to 6mm OD Tube
A11570-06	Reducing Straight Connector, Push to Connect, 10mm OD to 8mm OD Tube
A11570-07	Reducing Straight Connector, Push to Connect, 12mm OD to 8mm OD Tube
A11570-08	Reducing Straight Connector, Push to Connect, 12mm OD to 10mm OD Tube

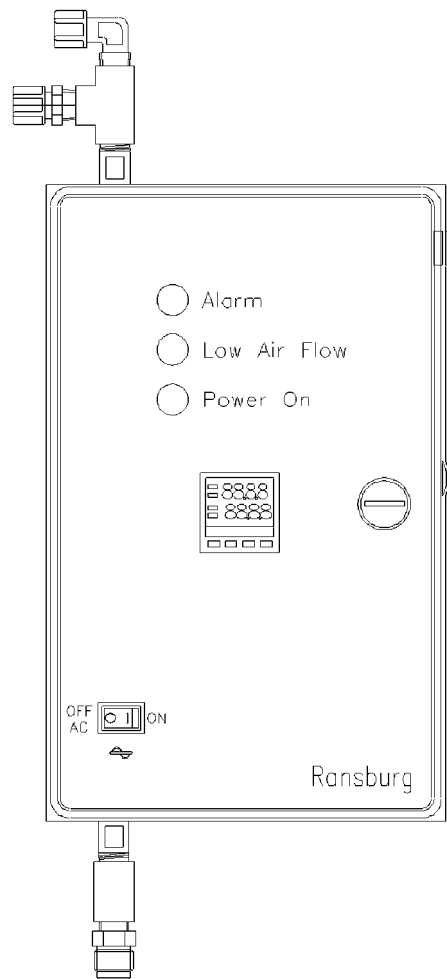

A11065-05
AIR HEATER

RECOMMENDED SPARE PARTS		
Part #	Description	Qty.
A12777-XX	Air Turbine Assembly*	1
77762-04	Collect, 8mm	2
A12796-00	Fluid Tube Assembly	1
77591-00	Fiber Optic Transmitter Assembly	1
77516-04	Collect, 4mm	1
77367-00	Valve Seat Assembly	5
LSFI0022-04	Fitting, 1/4" O.D. X AN	1
EMF-203-04	Front Ferrule, 1/4" O.D. Tubing	2
EMF-203-04	Back Ferrule, 1/4" O.D. Tubing	2
A12807-00	Screw M10 X 16mm Nylon SHCS	1
A12808-00	Screw M12 X 25mm Nylon SHCS	1
78949-00	Fluid Valve Assembly	5
A12409-XX	Fiber Optic Cable	1
79001-34	O-Ring, Solvent Proof	1
79001-30	O-Ring, Solvent Proof	1
79001-41	O-Ring, Solvent Proof	1
7554-127	O-Ring, Solvent Resistant	1
A13096-00	Tube Receiver, 4mm	2
A13118-00	Tube Fitting, 4mm	2
79001-22	O-Ring, Solvent Proof	2
A12816-00	Tube Fitting, 8mm	2
79001-04	O-Ring, Solvent Proof - (For all valve manifold tube fittings)	3-5
79001-40	O-Ring, Solvent Proof	3
79001-42	O-Ring, Solvent Proof	1
79001-44	O-Ring, Solvent Proof	1
A11119-10	Screw M4 X 10mm SS SHCS	2
A10468-10	Screw M6 X 10mm SS SHCS	2
A13382-00	Resistor Assembly	2
A13288-00	Tube Receiver, 8mm	1
A13287-00	Tube Fitting, 8mm x 6mm	1
A13289-00	Tube Fitting, 8mm x 5mm	1
A10468-12	Screw M6 X 12mm SS SHCS	2
78449-00	Fitting, Fluid	1
A13030-00	Set Screw M8 X 12mm Cup Pt. SS	2
A12824-00	Cup Wash "Y" Fitting	6
A11252-01	Cup Wash Tubing	10-20 ft.
A12821-00	Cup Wash Fitting	2
A12822-00	Cup Wash Ferrule	4

* Customer must verify their spindle for o-ring A replacement

RECOMMENDED SPARE PARTS (Cont.)		
Part #	Description	Qty.
Select Option Below - Fluid Tip Size/Style		
A11240-01	.028/0.7MM	1
A11240-02	.035/0.9mm	1
A11240-03	.043/1.1mm	1
A11240-04	.047/1.2mm	1
A11240-05	.062/1.6mm	1
A11240-06	.039/1.0mm	1
A13601-00	.010/0.25mm	1
A13625-00	.028/0.7MM Straight	1
A13625-01	.035/0.9mm Straight	1
A13625-02	.039/1.0mm Straight	1
A13625-03	.043/1.1mm Straight	1
A13625-04	.047/1.2mm Straight	1
A13625-05	.062/1.6mm Straight	1
A13625-06	.093/2.4mm Straight	1
A13625-07	.125/3.2mm Straight	1
A13625-08	.010/0.25mm Straight	1
A13645-00	.028/0.7MM Industrial	1
A13645-01	.035/0.9mm Industrial	1
A13645-02	.039/1.0mm Industrial	1
A13645-03	.043/1.1mm Industrial	1
A13645-04	.047/1.2mm Industrial	1
A13645-05	.062/1.6mm Industrial	1
A13645-06	.093/2.4mm Industrial	1
A13645-07	.125/3.2mm Industrial	1
A13645-08	.010/0.25mm Industrial	1
Select Option Below - Bell Cup Assembly W/Splash Plate		
A12942-02	65MM Aluminum, Plated	1
A12833-01	30mm Aluminum, Plated	1
A13207-00	15mm Titanium	1
A12833-03	30mm Titanium	1
A13676-00	65mm Titanium	1
Select Option Below - Bell Cup Only		
A12782-00	65MM Aluminum, Plated	1
A12832-00	30mm Aluminum, Plated	1
A12936-00	15mm Titanium	1
A13531-00	30mm Titanium	1
A13675-00	65mm Titanium	1

RECOMMENDED SPARE PARTS (Cont.)		
Part #	Description	Qty.
Select Option Below - Splash Plate Only		
A13644-00	For 65mm Bell Cups	1
A13274-00	For 30mm Bell Cups	1
Select Option Below Fluid Coil		
79879-00	1/4" OD X .125" ID, PFA, High Conductive Paints (16 Coils)	1
79879-01	1/4" OD X .170" ID, PFA (12 Coils)	1
Select Option Below Shaping Air Kit A13032-01 Dual Flex (65mm)		
A12909-00	Outer Shroud (65mm)	1
A12911-00	Shaping Air Ring (65mm)	1
A12910-00	Shape Air Manifold (65mm)	1
79001-11	O-Ring	1
79001-10	O-Ring	1
79001-35	O-Ring	1
7554-72	O-Ring	1
79001-16	O-Ring	1
A12898-00	Shape Air Plug	1
Select Option Below Shaping Air Kit A13032-02 Mono Flex (65mm)		
A12779-01	Outer Shroud (65mm)	1
A12896-00	Shape Air Manifold (65mm)	1
79001-52	O-Ring	1
79001-10	O-Ring	1
7554-72	O-Ring	1
79001-16	O-Ring	1
A12898-00	Shape Air Plug	1
Select Option Below Shaping Air Kit A13032-03 (30mm)		
A12830-00	Outer Shroud (30mm)	1
A12831-00	Shape Air Manifold (30mm)	1
79001-52	O-Ring	1
79001-10	O-Ring	1
7554-72	O-Ring	1
79001-16	O-Ring	1
A12898-00	Shape Air Plug	1

RECOMMENDED SPARE PARTS (Cont.)		
Part #	Description	Qty.
Select Option Below Shaping Air Kit A13206-00 (15mm)		
A12933-00	Outer Shroud	1
A12935-00	Inner Shape Air Ring	1
A12934-00	Spacer	1
79001-10	O-Ring	1
79001-57	O-Ring	1

APPENDIX A

TESTS OF THE STATIONARY EQUIPMENT

The tests shall be carried out for each single spraying system. The test shall be carried out by skilled persons and include the tests according to this table and the internal notes.

SURVEY OF TESTS TABLE		
Kind of Test	Requirements	Review & Testing Interval
The stationary equipment for electrostatic coating with ignitable liquid coating materials shall be tested for occupationally safe state	<ul style="list-style-type: none"> In this context, especially the disconnection threshold, the overcurrent I_0 and the minimum voltage U_{min} shall be defined and documented with respect to operational and local conditions. 	Every 12 months
Effectivity of forced ventilation (exhaust air systems)	<ul style="list-style-type: none"> Ventilation must be properly interlocked with high voltage power supply. Forced ventilation must be proved to be working effectively. 	Continuously
Safe disconnection of high voltage shall be tested for voltage-controlled and constant voltage operation	<ul style="list-style-type: none"> The disconnection threshold I_0 shall be defined and documented with respect to operational and local conditions. It shall be tested if the high voltage is disconnected in case of inadmissible increase of the operational current I_b and if the disconnection threshold I_0 is reached. In this context, the disconnection threshold I_0 defined during the initial test shall be checked. A disconnection threshold I_0 giving rise to expect an occurrence of hazardous discharges or flashover between parts under high voltage and earthed parts of the plant in case the safety distance drops below the permissible limit, is not permitted. 	At every switch on
Safe disconnection of high voltage shall be tested for voltage-controlled and constant voltage operation	<ul style="list-style-type: none"> Validate safety circuits are performing as designed. 	Monthly
Protection against too high discharge energy	<ul style="list-style-type: none"> Discharge energy must be less than 300 mJ prior to reaching the parts. 	Weekly
Protection against ignition of cleaning agents	<ul style="list-style-type: none"> Use non-flamable cleaning agents if possible. Those used for equipment flushing should have flash points equal to or higher than those of the coating material. Those solvents used for cleaning must have a flash point at minimum of 5°C (9°F) greater than the ambient temperature. It is the end users responsibility to insure this condition is met. 	Before each cleaning

SURVEY OF TESTS TABLE (Cont.)		
Kind of Test	Requirements	Review & Testing Interval
<p>Effectivity of measures for protection against direct contact</p> <p>Interlocks / protection against entrance</p>	<ul style="list-style-type: none"> On all doors and openings of the spraying area where the hazard of contact with parts under high voltage exists the presence of the high voltage shall be safeguarded in such a way that the high voltage is disconnected when entrance is gained. The interlock shall satisfy the performance level d of EN ISO 13849-1. Other openings of the spraying area through which parts under high voltage could be contacted shall be locked in such a way to be only opened by keys or tools. When using systems of types C-L and D-L an interlock of the high voltage with all doors and openings shall be installed to prevent an electric shock of persons. 	Weekly
<p>Effectivity of grounding measures</p>	<ul style="list-style-type: none"> All conductive components of the equipment, like floor, walls, ceilings, fences, conveyors, workpieces, containers for coating material, reciprocators or elements or elements of construction etc. within the spraying area, except for parts under high voltage for operational reasons, shall be connected to the grounding system. Parts of the booth shall be earthed in compliance with EN 12215:2004. If an appropriate grounding of the conductive parts according to 5.7.1 cannot be achieved, the possible discharge energy shall not exceed 0, 24mJ. The resistance to earth from the suspending point of each workpiece shall not exceed 1 MΩ. The voltage during measurement shall be 500 V or 1000 V. The construction of hangers shall ensure that the workpieces remain earthed during the coating process. <p>Note: Since workpieces are often earthed by metallic hooks, it is important to clean these hooks regularly or to design them in such a way, that the built-up of insulating layers of coating materials is prevented.</p> <ul style="list-style-type: none"> If an appropriate grounding of the workpiece according to 5.7.1 cannot be ensured, the dissipation of electrical charges at the workpiece by other devices, e.g. ionizers, is permitted. Such devices shall not exceed the permitted discharge energy of the spraying systems, for which they are used. Moreover, these devices shall be submitted to the same test for admissible discharge energy as the spraying systems they are used with. The dissipation device shall be interlocked with the spraying system in such a way to disconnect the high voltage and to stop coating in case of failure of this dissipation device. 	Weekly

SURVEY OF TESTS TABLE (Cont.)		
Kind of Test	Requirements	Review & Testing Interval
Effectivity of locally acting fire extinguishing system	<ul style="list-style-type: none"> In addition to a room-protection system, locally acting fire extinguishing systems (installed fixedly and allocated to the object) shall give effective protection for the hazard zone between the outlet of coating materials and the workpiece. It shall be proved for each individual case, if the aspects of the locally acting fire extinguishing systems and the room-protection system could be satisfied by one fire extinguishing system. Electrostatic spraying systems shall be equipped with locally acting automatic fire extinguishing systems which are actuated immediately in case of fire. When the fire extinguishing system has been activated, the high voltage supply, the supply of coating materials and the pressurized air shall be cut-off automatically. <p>EN 13478 shall be observed.</p> <p>It shall be checked in each individual case, whether a present room-protection system is also able to fulfill the function of a locally acting automatic fire extinguishing system.</p>	Every 6 months
Conductive parts of the spraying material supply system	<ul style="list-style-type: none"> Where conductive parts are used for the coating material supply system, these parts shall be either bonded to earth or connected with the high voltage supply system so that the potential level is invariably identical with that of the electrostatic spraying system. 	Weekly
Minimum clearance in air	<ul style="list-style-type: none"> Insure all earthed items are outside the safe use distance of 204mm. 	Weekly
Other tests	<ul style="list-style-type: none"> In compliance with EN 12215: 2004 	In compliance with EN 12215:2004

WARRANTY POLICIES

LIMITED WARRANTY

Ransburg will replace or repair without charge any part and/or equipment that fails within the specified time (see below) because of faulty workmanship or material, provided that the equipment has been used and maintained in accordance with Ransburg's written safety and operating instructions, and has been used under normal operating conditions. Normal wear items are excluded.

THE USE OF OTHER THAN RANSBURG APPROVED PARTS VOID ALL WARRANTIES.

SPARE PARTS: One hundred and eighty (180) days from date of purchase, except for rebuilt parts (any part number ending in "R") for which the warranty period is ninety (90) days.

EQUIPMENT: When purchased as a complete unit, (i.e., guns, power supplies, control units, etc.), is one (1) year from date of purchase. **WRAPPING THE APPLICATOR, ASSOCIATED VALVES AND TUBING, AND SUPPORTING HARDWARE IN PLASTIC, SHRINK-WRAP, OR ANY OTHER NON-APPROVED COVERING, WILL VOID THIS WARRANTY.**

RANSBURG'S ONLY OBLIGATION UNDER THIS WARRANTY IS TO REPLACE PARTS THAT HAVE FAILED BECAUSE OF FAULTY WORKMANSHIP OR MATERIALS. THERE ARE NO IMPLIED WARRANTIES NOR WARRANTIES OF EITHER MERCHANTABILITY OR FITNESS FOR A PARTICULAR PURPOSE. RANSBURG ASSUMES NO LIABILITY FOR INJURY, DAMAGE TO PROPERTY OR FOR CONSEQUENTIAL DAMAGES FOR LOSS OF GOODWILL OR PRODUCTION OR INCOME, WHICH RESULT FROM USE OR MISUSE OF THE EQUIPMENT BY PURCHASER OR OTHERS.

EXCLUSIONS:

If, in Ransburg's opinion the warranty item in question, or other items damaged by this part was improperly installed, operated or maintained, Ransburg will assume no responsibility for repair or replacement of the item or items. The purchaser, therefore, will assume all responsibility for any cost of repair or replacement and service related costs if applicable.

MANUAL CHANGE SUMMARY

This manual was published to supersede Service Manual **LN-9247-13 Aerobell 168** to make the following changes:

1. Updated Atex product marking definitions with updated label 80108 (Page 7).
2. Updated fluid tips (Page 9).
3. Updated Tables C and D (Page 10).
4. Added Titanium Bell Cups to drawings (Page 11).
5. Update distance specifications (Page 15).
6. Update hose specifications (Page 26).
7. Added "Fluid Tip Stream and Tip Style Use" (Page 38).
8. Added "Turbine Exhaust Air" (Page 40).
9. Added "Resistor Assembly" (Page 47).
10. Updated "Disassembly Procedures" steps 18 -25 with new pictures (Page 76).
11. Revised model ordering number, added Table "J" (Page 82).
12. Updated Tables B and C (Page 83).
13. Updated Table D (Page 84).
14. Added Table J (Page 85).
15. Updated "Applicator Parts Breakdown" table (Page 87).
16. A13668-00 was changed from A12892-00 (Page 88).
17. New drawing of A13401 Machine Mount Kit with Valves (Page 89).
18. Revised Machine Mount Kit Parts List (Page 90).
19. Revised Table A (Page 91).
20. New drawing for A13402 Robot Mount Kit with Valves (Page 92).
21. Revised Robot Mount Kit Parts List (Page 93).
22. Revised Table A (Page 94).
23. Updated Recommended Spare Parts List (Page 102-105).

Manufacturing

1910 North Wayne Street
Angola, Indiana 46703-9100
Telephone: 260-665-8800
Fax: 260-665-8516

Technical Service — Assistance

320 Philips Ave.
Toledo, Ohio 43612-1493
Telephone (toll free): 800-233-3366
Fax: 419-470-2233

Technical Support Representative will direct you to the appropriate telephone number for ordering Spare Parts.