

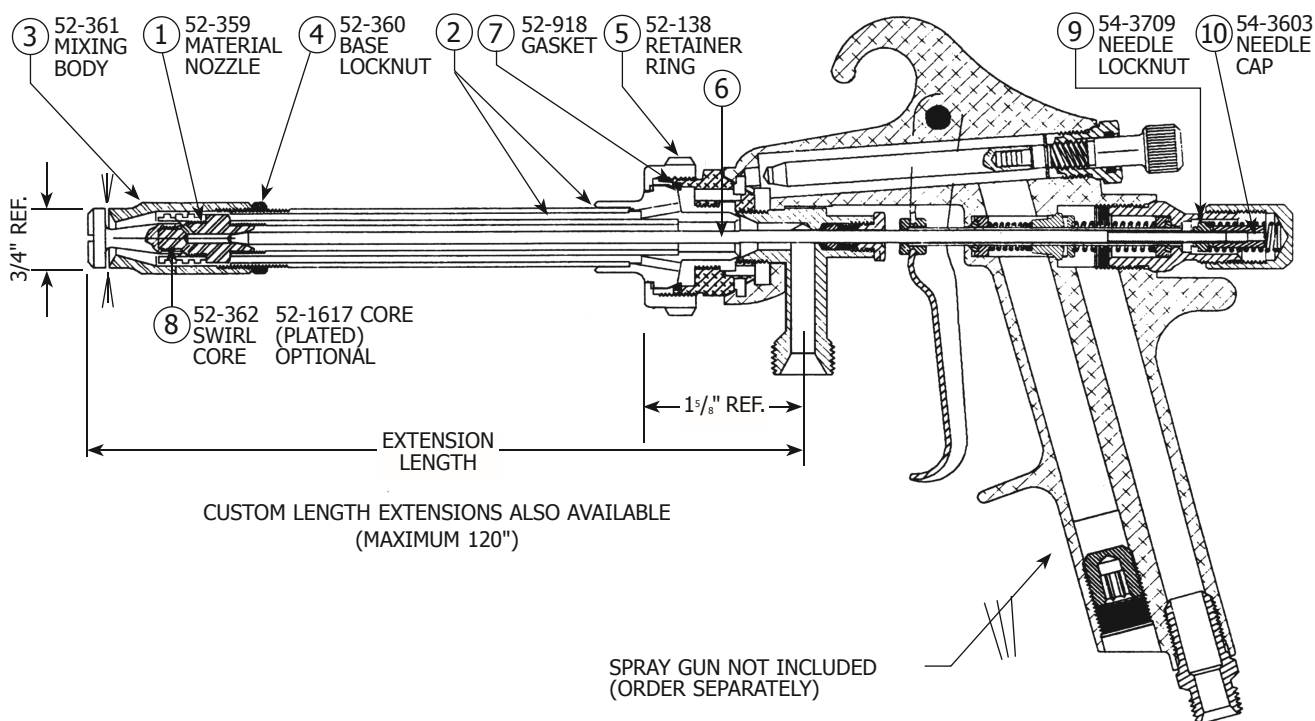

NOZZLE EXTENSIONS FOR MODEL 95 HAND GUNS

**"C" NOZZLE EXTENSIONS (360° CIRCULAR SPRAY)
FOR MODEL 95 HAND SPRAY GUNS
(FOR MEDIUM TO HEAVY VISCOSITY MATERIALS
.093 ORIFICE)**



EXTENSION ASSEMBLY NO.	EXTENSION LENGTH	② AIR/FLUID TUBE ASSEMBLY	⑥ NEEDLE VALVE
52-3885	6"	52-368	52-3873
52-3886*	9"	52-369	52-3874
52-3887	12"	52-370	52-3875
52-3888*	15"	52-371	52-3876
52-3889	18"	52-372	52-3877
52-3890	24"	52-373	52-3878
52-3891*	30"	52-374	52-3879
52-3892	36"	52-375	52-3880
52-3893	48"	52-376	52-3881
52-3894	60"	52-377	52-3882
52-3895	72"	52-378	52-3883
52-3896	84"	52-379	52-3884

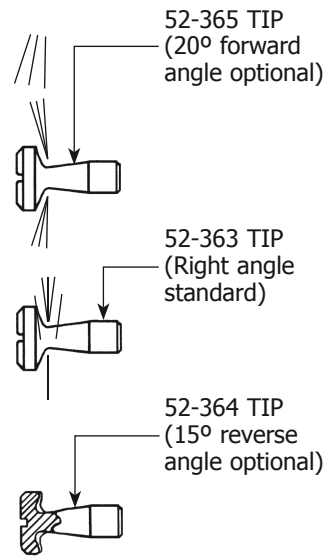

(Nozzle extensions and gun assembly reference drawing 52-3885)

*Non-standard extensions. Please call for pricing and ordering instructions.

"HC" NOZZLE EXTENSIONS (360° CIRCULAR SPRAY) FOR MODEL 95 HAND SPRAY GUNS (FOR HEAVY VISCOSITY FLUIDS .110 ORIFICE)

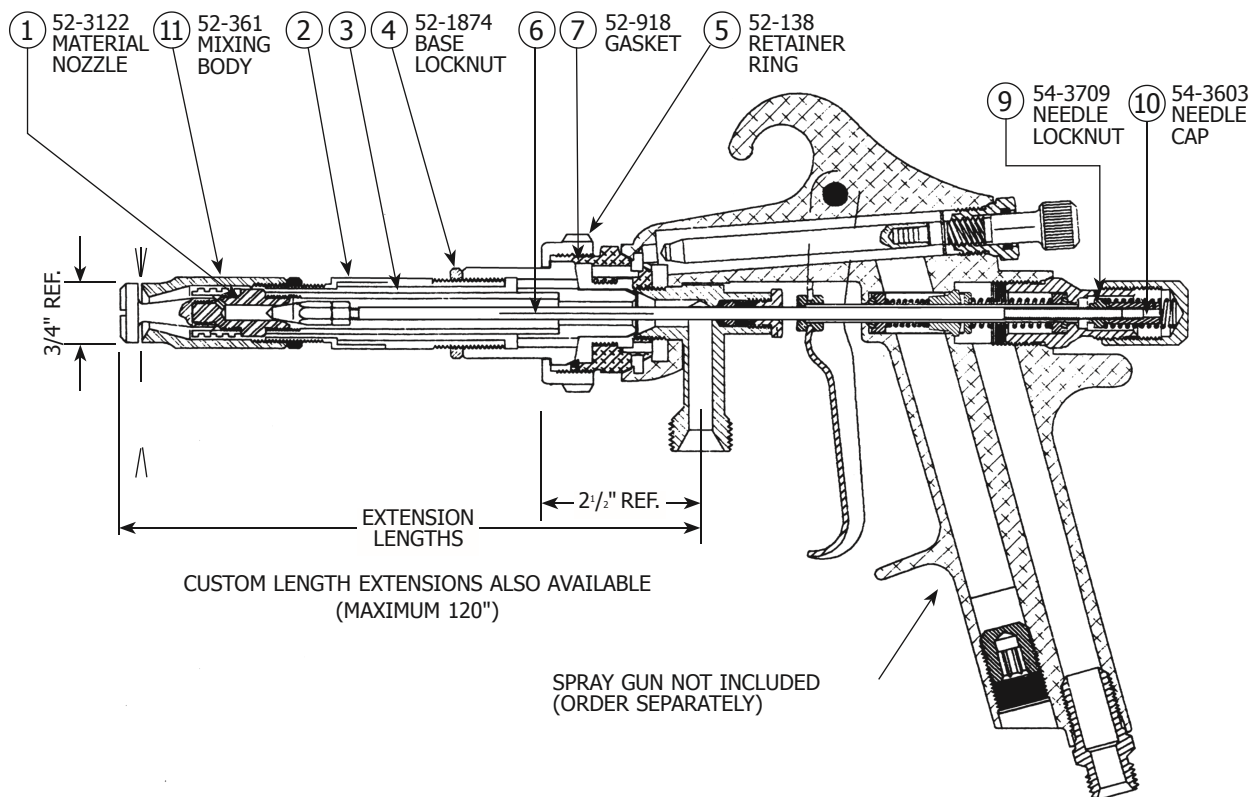

EXTENSION ASSEMBLY NO.	EXTENSION LENGTH	② AIR TUBE ASSEMBLY	③ MATERIAL TUBE ASSEMBLY	⑥ NEEDLE VALVE
52-3923*	6"	52-3139	52-1878	52-3909
52-3924	12"	52-3140	52-2999	52-3910
52-3925*	18"	52-3141	52-1879	52-3911
52-3926*	24"	52-3142	52-1880	52-3912
52-3927*	30"	52-3143	52-1881	52-3913
52-3928	36"	52-3144	52-1978	52-3914
52-3929*	42"	52-3199	52-1882	52-3915
52-3930*	43.5"	52-3145	52-3160	52-3916
52-3931*	48"	52-3146	52-1883	52-3917
52-3932*	56"	52-3200	52-2379	52-3918
52-3933*	60"	52-3201	52-1884	52-3919
52-3934*	72"	52-3202	52-1885	52-3920
52-3935*	80"	52-3203	52-1886	52-3921
52-3936*	84"	52-3204	52-1887	52-3922

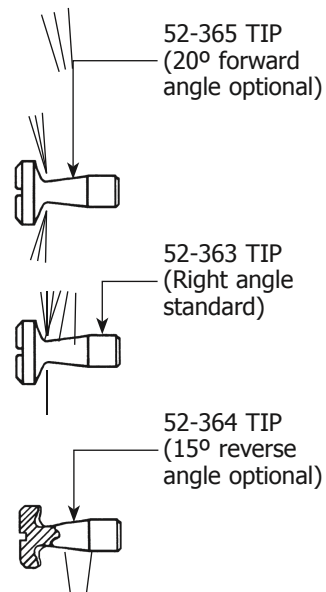

(Nozzle extensions and gun assembly reference drawing 52-3923)

*Non-standard extensions. Please call for pricing and ordering instructions.

**"HCVT" NOZZLE EXTENSIONS (360° CIRCULAR SPRAY)
FOR MODEL 95 HAND SPRAY GUNS
(FOR HEAVY VISCOSITY ABRASIVE FLUIDS .110 ORIFICE)**

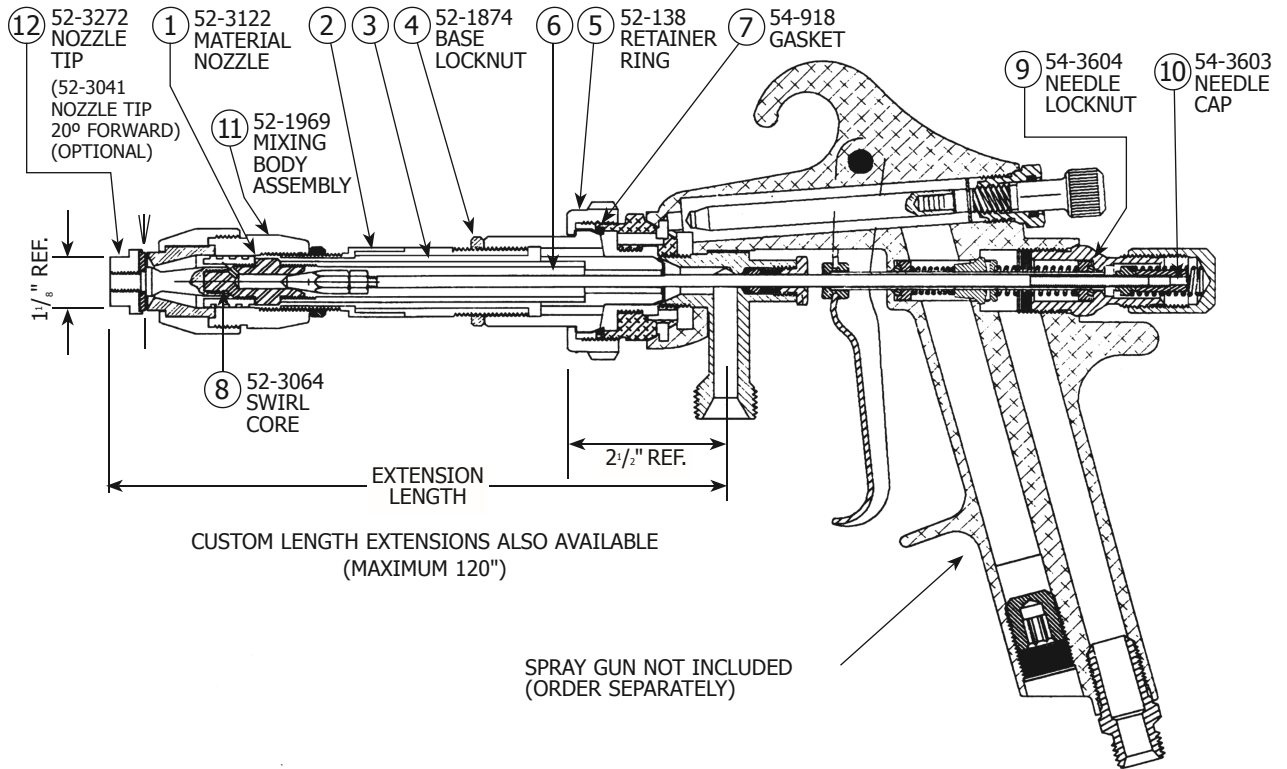

EXTENSION ASSEMBLY NO.	EXTENSION LENGTH	② AIR TUBE ASSEMBLY	③ MATERIAL TUBE ASSEMBLY	⑥ NEEDLE VALVE
52-3951*	6"	52-3199	52-1878	52-3909
52-3952*	12"	52-3140	52-2999	52-3910
52-3953*	18"	52-3141	52-1879	52-3911
52-3954*	24"	52-3142	52-1880	52-3912
52-3955*	30"	52-3143	52-1881	52-3913
52-3956*	36"	52-3144	52-1978	52-3914
52-3957*	42"	52-3199	52-1882	52-3915
52-3958*	43.5"	52-3145	52-3160	52-3916
52-3959*	48"	52-3146	52-1883	52-3917
52-3960*	56"	52-3200	52-2379	52-3918
52-3961*	60"	52-3201	52-1884	52-3919
52-3962*	72"	52-3202	52-1885	52-3920
52-3963*	80"	52-3203	52-1886	52-3921
52-3964*	84"	52-3204	52-1887	52-3922

(Nozzle extensions and gun assembly reference drawing 52-3951)

*Non-standard extensions. Please call for pricing and ordering instructions.

**"MC" NOZZLE EXTENSIONS (360° CIRCULAR SPRAY)
FOR MODEL 95 HAND SPRAY GUNS
(FOR MEDIUM VISCOSITY FLUIDS .079 ORIFICE)**

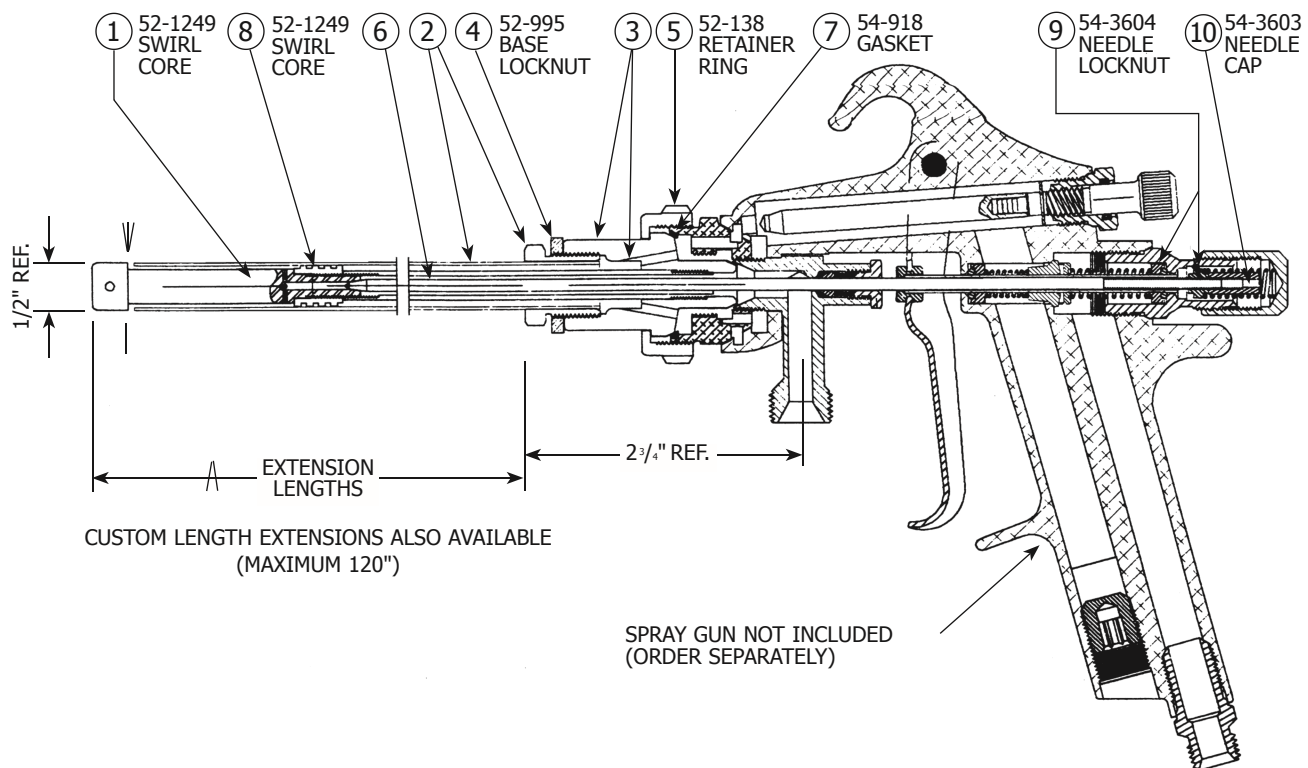

EXTENSION ASSEMBLY NO.	EXTENSION LENGTH	② AIR TUBE ASSEMBLY	③ MATERIAL TUBE ASSEMBLY	⑥ NEEDLE VALVE
52-3979*	6"	52-1294	52-1312	52-4003
52-3980*	9"	52-1295	52-1313	52-4004
52-3981*	12"	52-1296	52-1314	52-4005
52-3982*	15"	52-1297	52-1315	52-4006
52-3983*	18"	52-1298	52-1316	52-4007
52-3984*	24"	52-1299	52-1317	52-4008
52-3985*	36"	52-1300	52-1318	52-4009
52-3986*	48"	52-1301	52-1319	52-4010
52-3987*	60"	52-1302	52-1320	52-4011
52-3988*	72"	52-1271	52-1274	52-4012
52-3989*	76"	52-1272	52-1275	52-4013
52-3990*	80"	52-1273	52-1276	52-4014

(Nozzle extensions and gun assembly reference drawing 52-3979)

*Non-standard extensions. Please call for pricing and ordering instructions.

**"SA" NOZZLE EXTENSIONS (ROUND SPRAY PATTERN)
FOR MODEL 95 HAND SPRAY GUNS
(FOR MEDIUM VISCOSITY FLUIDS .078 ORIFICE)**

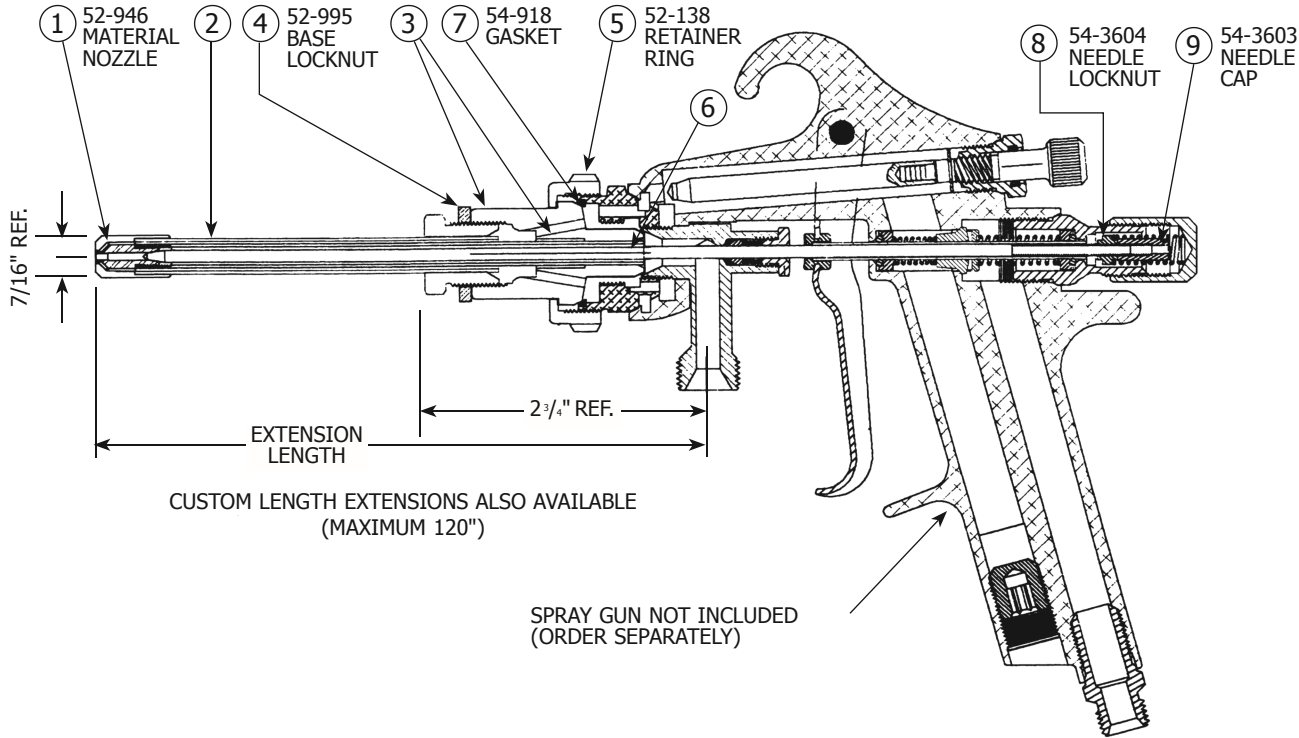

CUSTOM LENGTH EXTENSIONS ALSO AVAILABLE
(MAXIMUM 120")

SPRAY GUN NOT INCLUDED
(ORDER SEPARATELY)

EXTENSION ASSEMBLY NO.	EXTENSION LENGTH	② AIR TUBE ASSEMBLY	③ MATERIAL TUBE ASSEMBLY	⑥ NEEDLE VALVE
52-4015*	6"	52-971	52-983	52-3873
52-4016	9"	52-972	52-984	52-3874
52-4017*	12"	52-973	52-985	52-3875
52-4018*	15"	52-974	52-986	52-3876
52-4019*	18"	52-975	52-987	52-3877
52-4020*	24"	52-976	52-988	52-3878
52-4021*	30"	52-977	52-989	52-3879
52-4022*	36"	52-978	52-990	52-3880
52-4023*	48"	52-979	52-991	52-3881
52-4024*	60"	52-980	52-992	52-3882
52-4025*	72"	52-981	52-993	52-3883
52-4026*	84"	52-982	52-994	52-3884

(Nozzle extensions and gun assembly reference drawing 52-4015)

*Non-standard extensions. Please call for pricing and ordering instructions.

**"SC" NOZZLE EXTENSION (360° CIRCULAR SPRAY)
FOR MODEL 95 HAND SPRAY GUNS
(FOR LOW AND MEDIUM VISCOSITY FLUIDS .078 ORIFICE)**

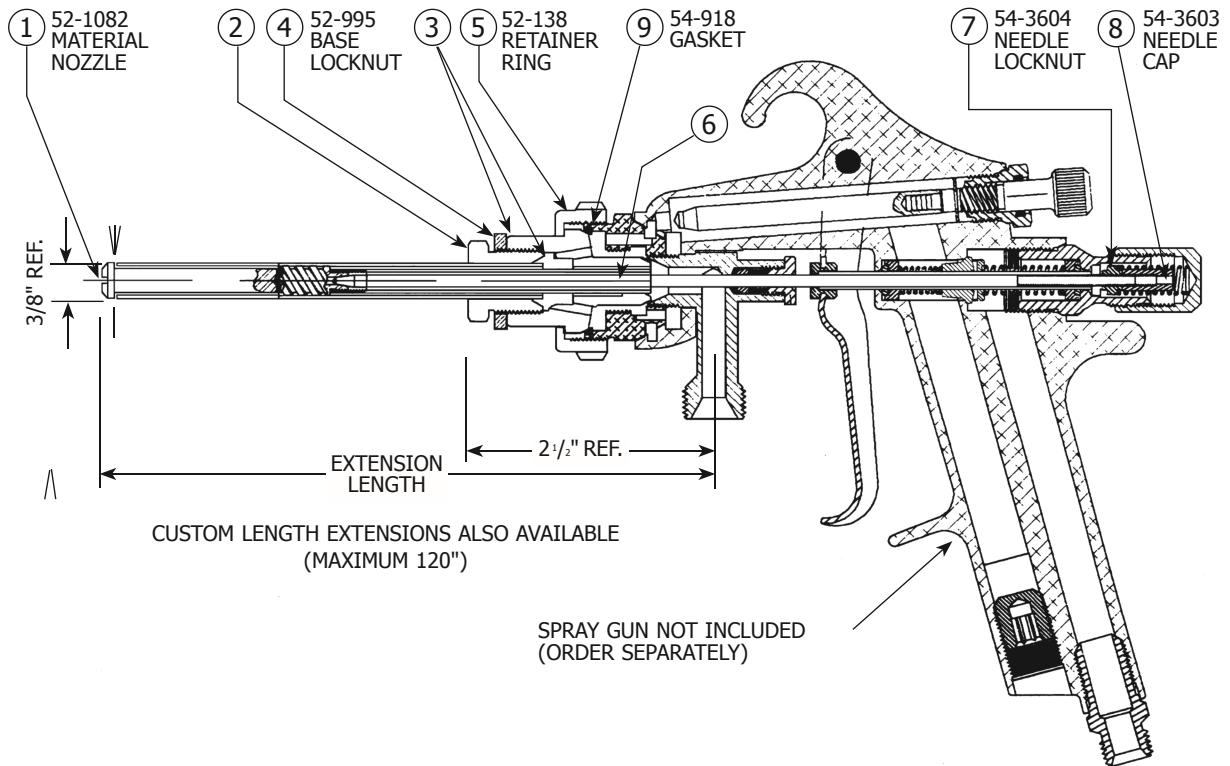

EXTENSION ASSEMBLY NO.	EXTENSION LENGTH	② AIR TUBE ASSEMBLY	③ MATERIAL TUBE ASSEMBLY	⑥ NEEDLE VALVE
52-3849*	9"	52-1058	52-1070	52-3873
52-3850	12"	52-1059	52-1071	52-3874
52-3851*	15"	52-1060	52-1072	52-3875
52-3852	18"	52-1061	52-1073	52-3876
52-3853*	21"	52-1062	52-1074	52-3877
52-3854	27"	52-1063	52-1075	52-3878
52-3855*	33"	52-1064	52-1076	52-3879
52-3856*	39"	52-1065	52-1077	52-3880
52-3857	51"	52-1066	52-1078	52-3881
52-3858	63"	52-1067	52-1079	52-3882
52-3859	75"	52-1068	52-1080	52-3883
52-3871*	87"	52-1069	52-1081	52-3884

(Nozzle extensions and gun assembly reference drawing 52-3849)

*Non-standard extensions. Please call for pricing and ordering instructions.

**"EA" NOZZLE EXTENSIONS (STANDARD EXTERNAL OR INTERNAL MIX NOZZLES)
FOR MODEL 95 HAND SPRAY GUNS
(FOR LOW, MEDIUM AND HEAVY VISCOSITY FLUIDS)**

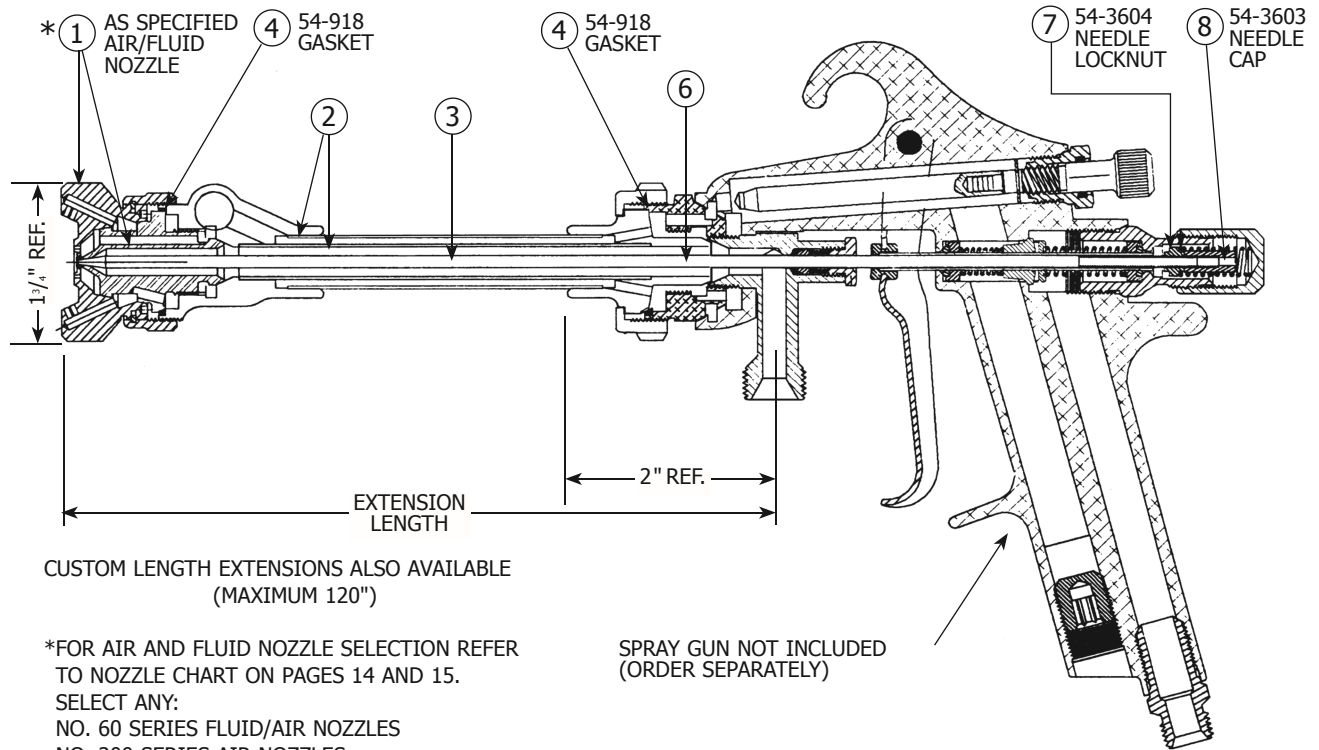

CUSTOM LENGTH EXTENSIONS ALSO AVAILABLE
(MAXIMUM 120")

*FOR AIR AND FLUID NOZZLE SELECTION REFER
TO NOZZLE CHART ON PAGES 14 AND 15.
SELECT ANY:
NO. 60 SERIES FLUID/AIR NOZZLES
NO. 200 SERIES AIR NOZZLES

SPRAY GUN NOT INCLUDED
(ORDER SEPARATELY)

EXTENSION ASSEMBLY NO.	EXTENSION LENGTH	② AIR/FLUID TUBE ASSEMBLY	③ NEEDLE VALVE
52-4051*	6"	52-598	52-4039
52-4052*	9"	52-599	52-4040
52-4053*	12"	52-600	52-4041
52-4054	15"	52-601	52-4042
52-4055*	18"	52-602	52-4043
52-4056*	24"	52-603	52-4044
52-4057*	30"	52-604	52-4045
52-4058	36"	52-605	52-4046
52-4059*	48"	52-606	52-4047
52-4060*	50"	52-607	52-4048
52-4061*	72"	52-608	52-4049
52-4062*	84"	52-609	52-4050

(Nozzle extensions and gun assembly reference drawing 52-4051)

*Non-Standard extensions. Please call for pricing and ordering instructions.

**"EB" NOZZLE EXTENSIONS
(90° SPRAY STANDARD EXTERNAL OR INTERNAL MIX NOZZLES)
FOR MODEL 95 HAND SPRAY GUNS
(FOR LOW, MEDIUM AND HEAVY VISCOSITY FLUIDS)**

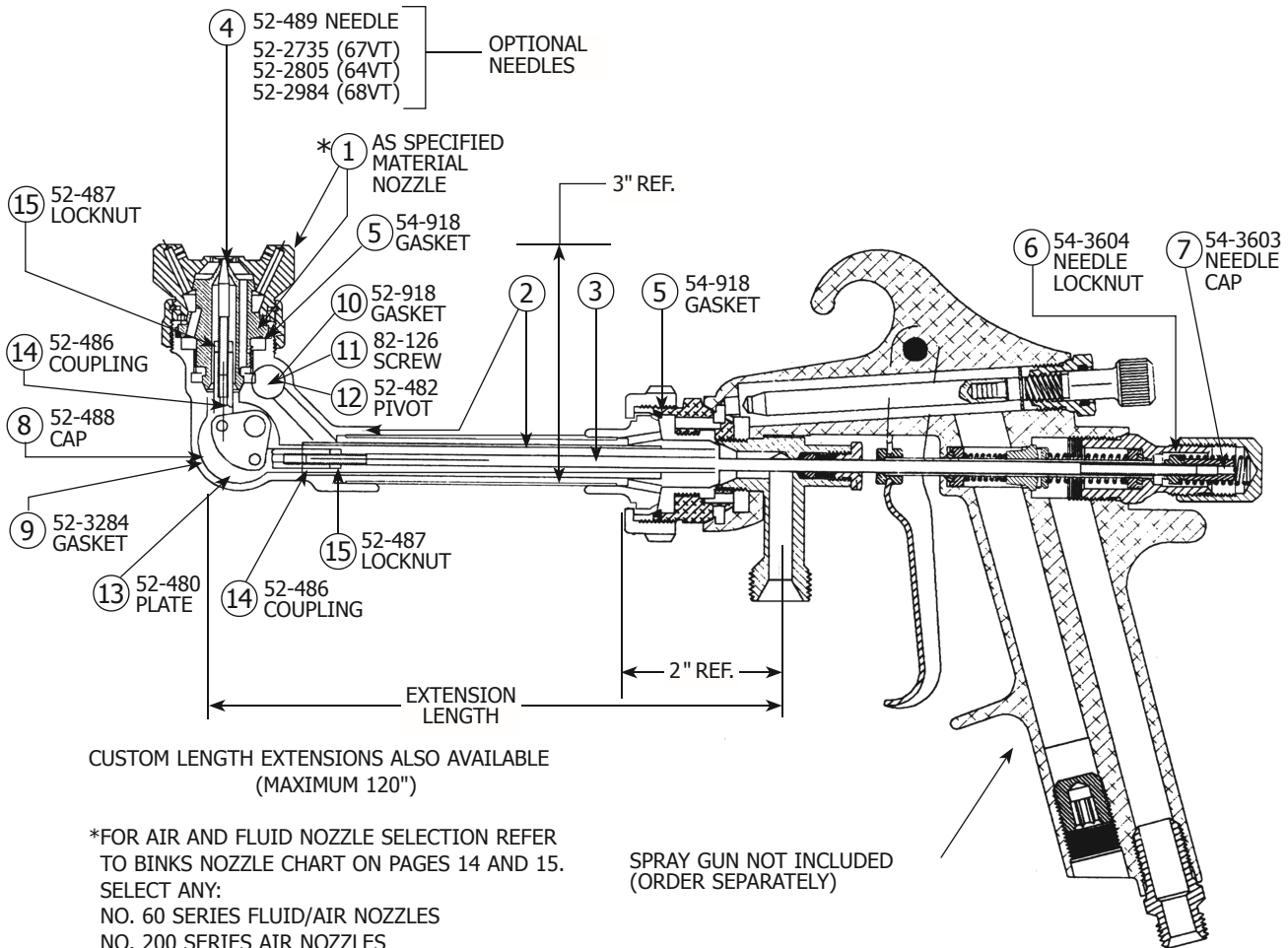

EXTENSION ASSEMBLY NO.	EXTENSION LENGTH	② AIR TUBE ASSEMBLY	③ NEEDLE ROD
52-4075*	6"	52-610	52-3605
52-4076*	9"	52-611	52-3606
52-4077*	12"	52-612	52-3607
52-4078*	15"	52-613	52-3608
52-4079*	18"	52-614	52-3609
52-4080*	24"	52-615	52-3610
52-4081*	30"	52-616	52-3611
52-4082*	36"	52-617	52-3612
52-4083*	48"	52-618	52-3613
52-4084*	50"	52-619	52-3614
52-4085*	72"	52-620	52-3615
52-4086*	84"	52-621	52-3616

(Nozzle extensions and gun assembly reference drawing 52-4075)

*Non-Standard extensions. Please call for pricing and ordering instructions.

**"EN" NOZZLE EXTENSIONS (STANDARD EXTERNAL OR INTERNAL MIX)
FOR MODEL 95 HAND SPRAY GUNS
(FOR LOW, MEDIUM AND HEAVY VISCOSITY FLUIDS)**

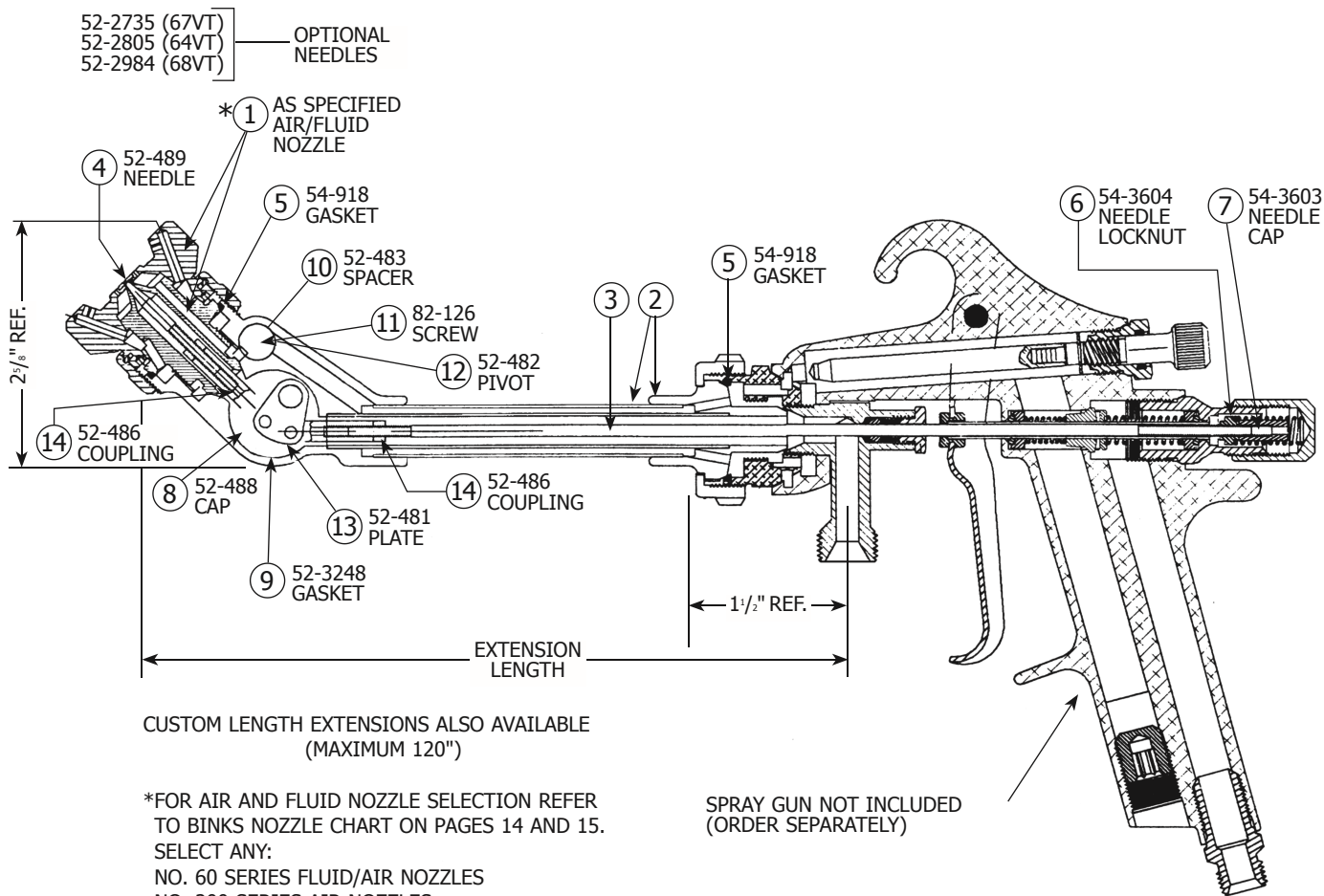

CUSTOM LENGTH EXTENSIONS ALSO AVAILABLE
(MAXIMUM 120")

*FOR AIR AND FLUID NOZZLE SELECTION REFER
TO BINKS NOZZLE CHART ON PAGES 14 AND 15.
SELECT ANY:
NO. 60 SERIES FLUID/AIR NOZZLES
NO. 200 SERIES AIR NOZZLES
NO. 700 SERIES AIR NOZZLES

SPRAY GUN NOT INCLUDED
(ORDER SEPARATELY)

EXTENSION ASSEMBLY NO.	EXTENSION LENGTH	② AIR/FLUID TUBE ASSEMBLY	③ NEEDLE ROD
52-4099*	6"	52-622	52-3605
52-4100*	9"	52-623	52-3606
52-4101	12"	52-624	52-3607
52-4102*	15"	52-625	52-3608
52-4103	18"	52-626	52-3609
52-4104*	24"	52-627	52-3610
52-4105*	30"	52-628	52-3611
52-4106	36"	52-629	52-3612
52-4107	48"	52-630	52-3613
52-4108*	60"	52-631	52-3614
52-4109*	72"	52-632	52-3615
52-4110*	84"	52-633	52-3616

(Nozzle extensions and gun assembly reference drawing 52-4099)

*Non-Standard extensions. Please call for pricing and ordering instructions.

**"EAX" NOZZLE EXTENSIONS (EXTERNAL OR INTERNAL MIX)
FOR MODEL 95 HAND SPRAY GUNS
(FOR LIGHT TO MEDIUM VISCOSITY FLUIDS)**

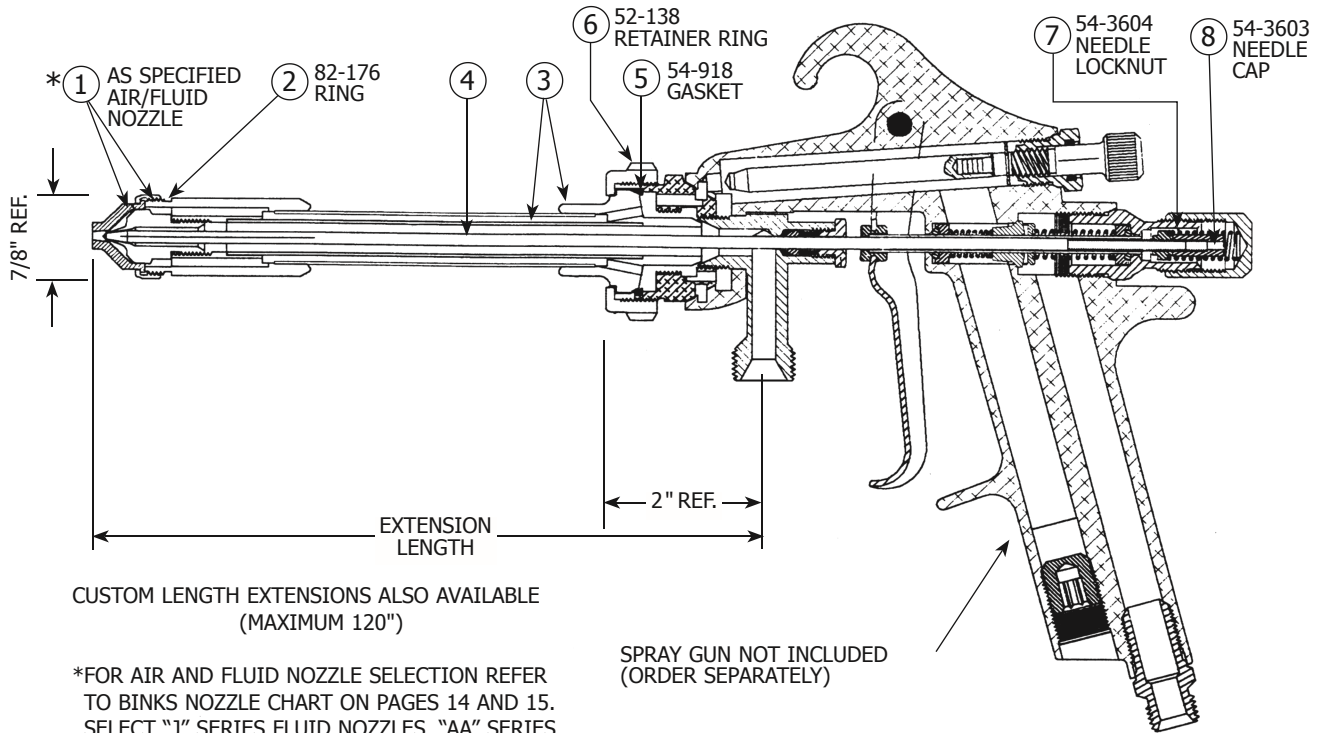

CUSTOM LENGTH EXTENSIONS ALSO AVAILABLE
(MAXIMUM 120")

*FOR AIR AND FLUID NOZZLE SELECTION REFER
TO BINKS NOZZLE CHART ON PAGES 14 AND 15.
SELECT "J" SERIES FLUID NOZZLES, "AA" SERIES
AIR CAPS

SPRAY GUN NOT INCLUDED
(ORDER SEPARATELY)

EXTENSION ASSEMBLY NO.	EXTENSION LENGTH	③ AIR/FLUID TUBE ASSEMBLY	④ NEEDLE VALVE
52-4135*	6"	52-141	52-4123
52-4136*	9"	52-142	52-4124
52-4137*	12"	52-143	52-4125
52-4138*	15"	52-144	52-4126
52-4139*	18"	52-145	52-4127
52-4140*	24"	52-146	52-4128
52-4141*	30"	52-147	52-4129
52-4142*	36"	52-148	52-4130
52-4143*	48"	52-149	52-4131
52-4144*	60"	52-150	52-4132
52-4145*	72"	52-151	52-4133
52-4146*	84"	52-152	52-4134

(Nozzle extensions and gun assembly reference drawing 52-4135)

*Non-Standard extensions. Please call for pricing and ordering instructions.

**"EBX" NOZZLE EXTENSIONS (STANDARD EXTERNAL OR INTERNAL MIX)
FOR MODEL 95 HAND SPRAY GUNS
(FOR LIGHT TO MEDIUM VISCOSITY FLUIDS)**

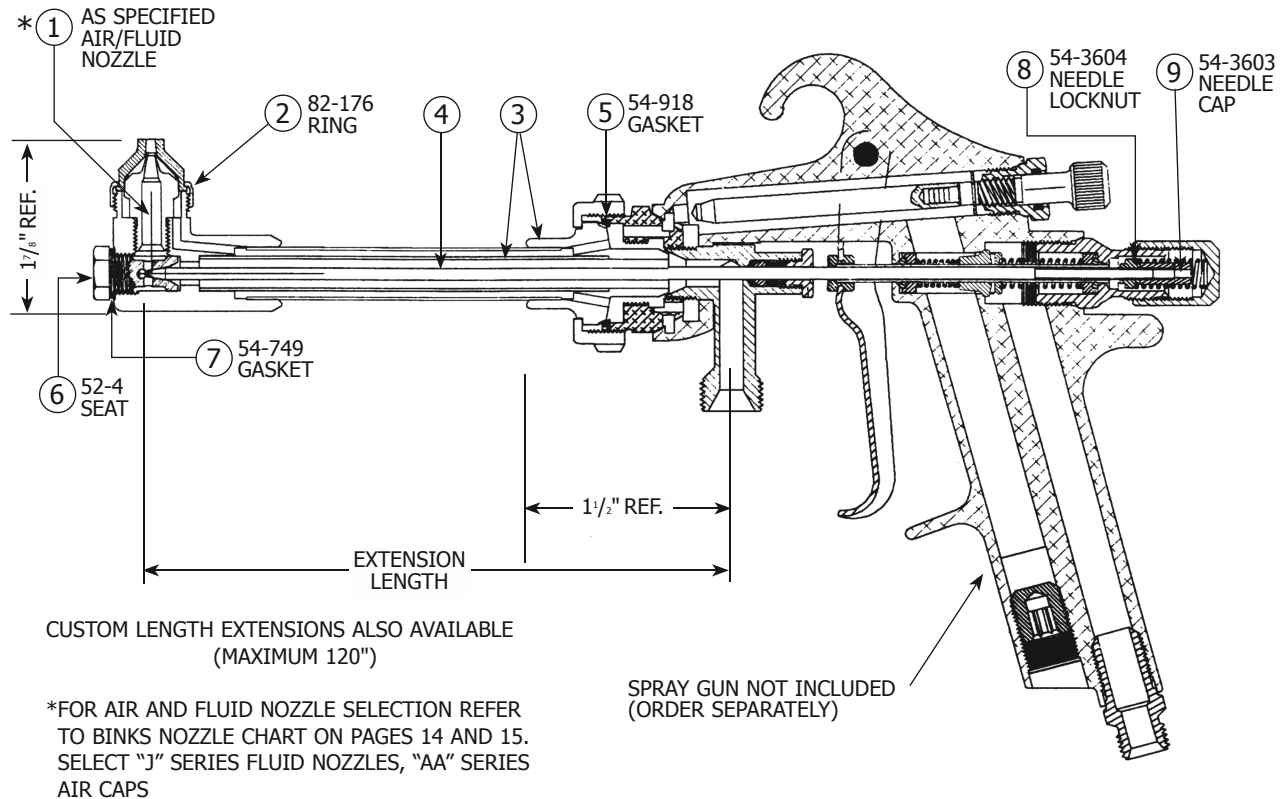

EXTENSION ASSEMBLY NO.	EXTENSION LENGTH	③ AIR/FLUID TUBE ASSEMBLY	④ NEEDLE VALVE
52-4159*	6"	52-165	52-3873
52-4160*	9"	52-166	52-3874
52-4161*	12"	52-167	52-3875
52-4162*	15"	52-168	52-3876
52-4163*	18"	52-169	52-3877
52-4164*	24"	52-170	52-3878
52-4165*	30"	52-171	52-3879
52-4166*	36"	52-172	52-3880
52-4167*	48"	52-173	52-3881
52-4168*	60"	52-174	52-3882
52-4169*	72"	52-175	52-3883
52-4170*	84"	52-176	52-3884

(Nozzle extensions and gun assembly reference drawing 52-4159)

*Non-Standard extensions. Please call for pricing and ordering instructions.

**"ENX" NOZZLE EXTENSIONS (STANDARD EXTERNAL OR INTERNAL UNIT)
FOR MODEL 95 HAND SPRAY GUNS
(FOR LIGHT TO MEDIUM VISCOSITY FLUIDS)**

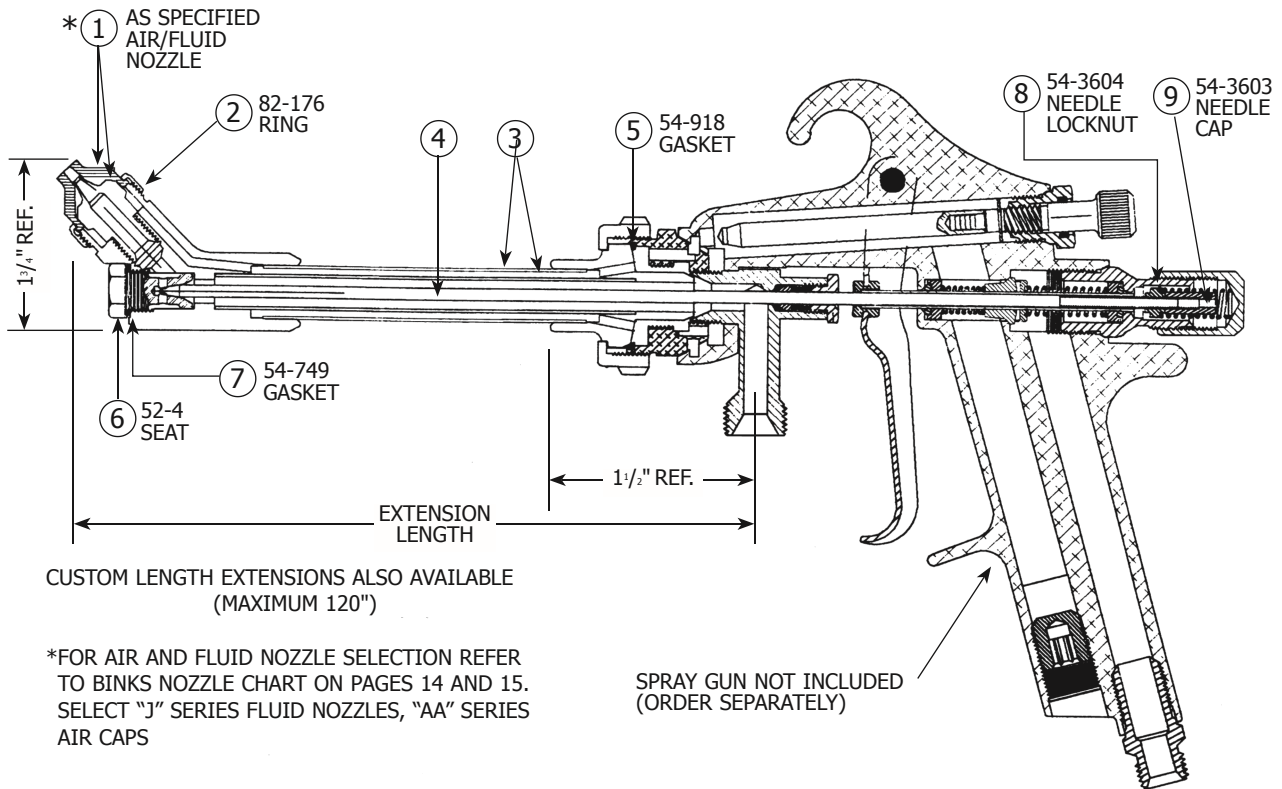

EXTENSION ASSEMBLY NO.	EXTENSION LENGTH	③ AIR/FLUID TUBE ASSEMBLY	④ NEEDLE VALVE
52-4183*	6"	52-153	52-3873
52-4184*	9"	52-154	52-3874
52-4185*	12"	52-155	52-3875
52-4186*	15"	52-156	52-3876
52-4187*	18"	52-157	52-3877
52-4188*	24"	52-158	52-3878
52-4189*	30"	52-159	52-3879
52-4190*	36"	52-160	52-3880
52-4191*	48"	52-161	52-3881
52-4192*	60"	52-162	52-3882
52-4193*	72"	52-163	52-3883
52-4194*	84"	52-164	52-3884

(Nozzle extensions and gun assembly reference drawing 52-4183)

*Non-Standard extensions. Please call for pricing and ordering instructions.

**"ERX" NOZZLE EXTENSIONS (STANDARD EXTERNAL OR INTERNAL MIX)
FOR MODEL 95 HAND SPRAY GUNS
(FOR LIGHT TO MEDIUM VISCOSITY FLUIDS)**

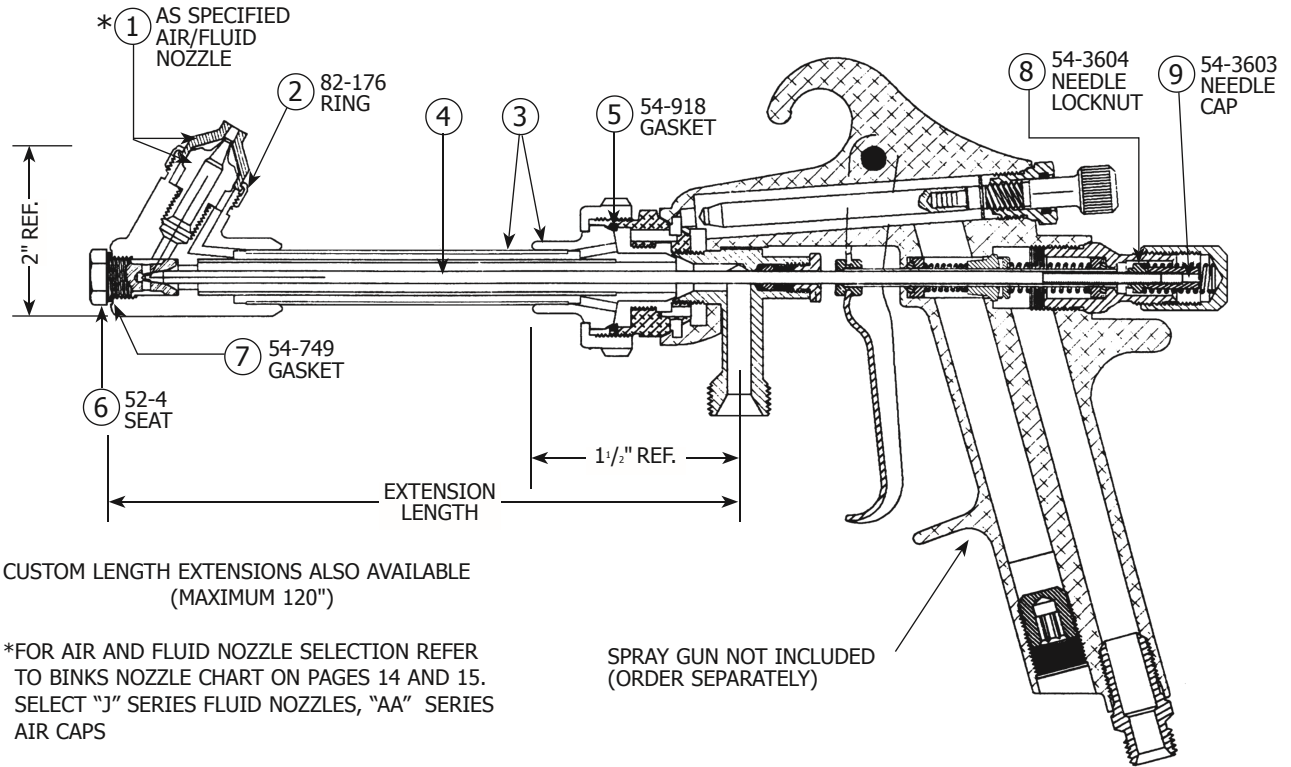

EXTENSION ASSEMBLY NO.	EXTENSION LENGTH	(3) AIR TUBE ASSEMBLY	(4) NEEDLE VALVE
52-4207*	6"	52-441	52-3873
52-4208*	9"	52-442	52-3874
52-4209*	12"	52-443	52-3875
52-4210*	15"	52-444	52-3876
52-4211*	18"	52-445	52-3877
52-4212*	24"	52-446	52-3878
52-4213*	30"	52-447	52-3879
52-4214*	36"	52-448	52-3880
52-4215*	48"	52-449	52-3881
52-4216*	60"	52-450	52-3882
52-4217*	72"	52-451	52-3883
52-4218*	84"	52-452	52-3884

(Nozzle extensions and gun assembly reference drawing 52-4207)

*Non-Standard extensions. Please call for pricing and ordering instructions.

NOZZLE SELECTION CHART FOR 95 SERIES SPRAY GUNS

TYPE OF FLUID TO BE SPRAYED	FLUID x AIR NOZZLES	NOZZLE TYPE [†]	CFM AT*			MAX PATTERN AT 8"
			30 PSI	50 PSI	70 PSI	
VERY THIN 14-16 Secs. No. 2 Zahn Wash Primers, Dyes, Stains, Solvents, Water, Inks	63SS x 63P	PE	4.5	7.5	10.0	5.0"
	63ASS x 63P	PE	5.1	8.7	12.2	11.0"
	63BSS x 63PB	PE	9.0	14.3	20.0	14.0"
	66SS x 66SD	SE	7.9	12.1	—	10.5"
	66SS x 66SK	SE	11.0	15.2	19.5	13.0"
	63BSS x 200	PI	3.1	5.2	6.4	12.0"
THIN 16-20 Secs. No. 2 Zahn Sealers, Lacquers, Primers, Inks, Lubricants Zinc Chromates, Acrylics	63ASS x 63P	PE	5.1	8.7	12.2	11.0"
	66SS x 66SK	SE	11.0	15.2	19.5	13.0"
	63BSS x 200	PI	3.1	5.2	6.4	12.0"
MEDIUM 19-30 Secs. No. 2 Zahn Synthetic Enamels, Varnishes, Shellacs, Fillers, Primers, Epoxies, Urethanes, Wax Emulsions	63BSS x 63PB	PE	9.0	14.3	20.0	14.0"
	63CSS x 63PR	PE	9.5	15.5	19.5	18.0"
	66SS x 66SD	SE	7.9	12.1	—	11.0"
	66SS x 66SK	SE	11.0	15.2	19.5	13.0"
	63CSS x 200	PI	3.1	5.2	6.4	12.0"
HEAVY (Cream-like) Over 28 Secs. No. 4 Ford House Paint, Wall Paint (Oil, Latex), Block Sealers, Mill Whites, Vinyls, Acrylics, Epoxies	67SS x 206	PI	6.0	9.5	13.0	15.0"
	68SS x 201	PI	4.6	6.8	9.1	11.0"
	66SS x 63PB	PE	9.0	14.3	20.0	14.0"
	67SS x 67PB	PE	9.5	14.9	19.5	12.0"
	68SS x 68PB	PE	9.5	14.1	19.1	12.0"
VERY HEAVY Unaggregated Block Fillers, Texture Coatings, Fire Retardants, Road Marking Paint, Bitumastics, Cellular plastisols	68SS x 206	PI	6.2	9.8	13.2	15.0"
	68SS x 68PB	PE	9.5	14.1	19.1	12.0"
	59ASS x 244	PI	7.8	11.5	15.2	12.0"
	59BSS x 250	PI	7.8	11.0	14.7	RD.
	59BSS x 252	PI	7.8	11.5	15.2	12.0"
ADHESIVES Waterbase, White Vinyl Glue, Solvent Base, Neoprenes (Contact Cements)	63CSS x 63PB	PE	9.0	14.3	20.0	14.0"
	66SS x 63PB	PE	9.5	15.5	19.5	15.0"
	67SS x 67PB	PE	9.5	14.1	19.1	12.0"
	63SS x 66SD	PE	7.9	12.1	16.2	4.0"
	63ASS x 66SD	PE	7.9	12.1	16.2	7.0"
CERAMICS AND SIMILAR ABRASIVE MATERIALS Glazes, Engobes, Porcelain Enamel	64VT x 64PA	PE	12.1	15.0	21.0	13.0"
	67VT x 67PD	PE	10.0	15.0	20.0	15.0"
	68VT x 68PB	PE	9.5	14.1	19.1	12.0"

Carbon steel fluid nozzles will not be available, only stainless steel. All needles are stainless steel. *Be certain your air supply is sufficient to operate nozzles selected. †PE- Pressure Feed, External. SE - Siphon Feed, External. PI - Pressure Feed, Internal.

Nozzle No.	59ASS	59BSS	59CSS	63SS	63ASS	63BSS	63CSS	65SS	66SS	67SS	68SS
Orifice Size	.171	.218	.281	.028	.040	.046	.052	.059	.070	.086	.110

NOZZLE SELECTION CHART FOR 95 SERIES SPRAY GUNS (cont.)

TYPE OF FLUID TO BE SPRAYED	FLUID x AIR NOZZLES	NOZZLE TYPE [†]	CFM AT*			MAX PATTERN AT 8"
			30 PSI	50 PSI	70 PSI	
Concrete Curing Compounds	63SS x 200	PI	3.1	5.2	6.4	15.0"
	67SS x 206	PI	6.0	9.5	13.0	18.0"
	68SS x 206	PI	6.2	9.8	13.2	20.0"
Multicolor Paints	66SS x 200	PI	3.1	5.2	—	12.0"
	67SS x 206	PI	6.0	9.5	—	15.0"
Teflons	63ASS x 63PB	PE	9.0	14.3	20.0	10.0"
	63BSS x 63PR	PE	9.5	15.5	19.5	15.0"
	66SS x 66SD	SE	7.9	12.1	—	7.0"
Hammers	63CSS x 63PB	PE	9.0	14.3	—	14.0"
	66SS x 63PB	PE	9.0	14.3	—	14.0"
	66SS x 66SD	SE	7.9	12.1	—	7.0"
Wrinkle Enamels	63CSS x 63PB	PE	9.0	14.3	20.0	10.0"
	66SS x 63PB	PE	9.0	14.3	20.0	10.0"
Zinc Rich Coatings	66SS x 67PD	PE	12.0	18.0	24.0	15.0"
	67VT x 67PB	PE	9.5	14.1	19.1	12.0"
Spatter Veiling Distress	66SS x 66PD	PE	3 @ 15 PSI			
	794 x 793	PE	3 @ 17 PSI			
	794 x 797	PE	3 @ 15 PSI			

Carbon steel fluid nozzles will not be available, only stainless steel. All needles are stainless steel. *Be certain your air supply is sufficient to operate nozzles selected. †PE- Pressure Feed, External. SE - Siphon Feed, External. PI - Pressure Feed, Internal.

Nozzle No.	59ASS	59BSS	59CSS	63SS	63ASS	63BSS	63CSS	65SS	66SS	67SS	68SS
Orifice Size	.171	.218	.281	.028	.040	.046	.052	.059	.070	.086	.110

NOZZLES FOR EAX, EBX, ENX, ERX EXTENSIONS

TYPE OF FLUID TO BE SPRAYED	FLUID x AIR NOZZLES	NOZZLE TYPE [†]	CFM AT*			MAX PATTERN AT 8"
			30 PSI	50 PSI	70 PSI	
LIGHT TO MEDIUM VISCOSITY Lacquers Enamels Primers	J2SS x AA1	PE	3.1	5.0	6.4	8.0"

FLUID NOZZLE ORIFICE SIZE

J2SS	.043"
------	-------

WARRANTY POLICY

Binks products are covered by Carlisle Fluid Technologies one year materials and workmanship limited warranty. The use of any parts or accessories, from a source other than Carlisle Fluid Technologies, will void all warranties. For specific warranty information please contact the closest Carlisle Fluid Technologies location listed below.

Carlisle Fluid Technologies reserves the right to modify equipment specifications without prior notice. DeVilbiss®, Ransburg®, MS®, BGK®, and Binks® are registered trademarks of Carlisle Fluid Technologies, Inc. ©2016 Carlisle Fluid Technologies, Inc. All rights reserved.



Binks is part of Carlisle Fluid Technologies, a global leader in innovative finishing technologies. For technical assistance or to locate an authorized distributor, contact one of our international sales and customer support locations.

USA/Canada

info@carlisleleft.com
Tel: 1-888-992-4657
Fax: 1-888-246-5732

Mexico

ventas@carlisleleft.com.mx
Tel: 011 52 55 5321 2300
Fax: 011 52 55 5310 4790

Brazil

vendas@carlisleleft.com.br
Tel: +55 11 5641 2776
Fax: 55 11 5641 1256

United Kingdom

info@carlisleleft.eu
Tel: +44 (0)1202 571 111
Fax: +44 (0)1202 573 488

France

info@carlisleleft.eu
Tel: +33(0)475 75 27 00
Fax: +33(0)475 75 27 59

Germany

info@carlisleleft.eu
Tel: +49 (0) 6074 403 1
Fax: +49 (0) 6074 403 281

China

mkt@carlisleleft.com.cn
Tel: +8621-3373 0108
Fax: +8621-3373 0308

Japan

overseas-sales@carlisleleft.co.jp
Tel: 081 45 785 6421
Fax: 081 45 785 6517

Australia

sales@carlisleleft.com.au
Tel: +61 (0) 2 8525 7555
Fax: +61 (0) 2 8525 7575

For the latest information about our products, visit www.carlisleleft.com.

