

Stewart R. Browne Manufacturing

Grounding and Bonding Applications For Control of Static Electricity



Generation and Control of Static Electricity

Introduction

Static electricity is a major cause of fires and explosions in many industries. The hazard of electrostatic spark ignition of flammable vapor can be minimized by taking actions to limit the accumulation of electrostatic charges to safe values. Of primary importance is the proper bonding and grounding of equipment and containers. In addition, charge accumulation in liquids must be limited, in many instances, by controlling the rate of charge generation and/or the rate of charge dissipation. Occasionally, such methods cannot be applied, and the use of inert gas in vapor spaces must be considered.

This bulletin addresses the hazards of static electricity, created by the handling and processing of flammable liquids.

Topics Include:

- Sources of Static Generation
- Methods of Static Control
- Nonconductive Plastic Containers and Stretch Film
- Bonding and Grounding Principles
- Testing and Inspection of Bonding/Grounding Systems
- Inerting Methods
- Earthing Electrodes
- Ground Verification

Sources of Static Generation

The most common generators of static electricity are processes involving flammable liquids. Static electricity is generated by liquids flowing through pipes, and in mixing, pouring, pumping, filtering, or agitating liquids. The rate of generation is influenced by the conductivity of the liquids, the amount of turbulence in the liquid, the interfacial surface area between the liquids and other surfaces, liquid velocity, and the presence of impurities.

Some specific locations where static electricity is generated include:

- **Piping Systems** - In piping systems the generation rate and the subsequent accumulation of static charge are a function of the flow rate, liquid velocity, pipe diameter, and pipe length.
- **Filling Operations** - The turbulence experienced in filling operations, caused by large flow rates, splashing or free-falling liquids, greatly increases the charge accumulation above the level generated in piping systems.
- **Filtration** - Filters, because of their large surface area, can generate as much as 200 times the electrostatic charge generated in the same piping system without filtration.
- **Dispersing Operations** - Of all operations in the coatings industry, dispersing operations can be particularly hazardous in view of the extremely high rate of charge generation when particulates are present. With poorly-conductive liquids the charge accumulation can cause hazardous sparking in the vapor space, such as to an exposed agitator blade in a mixer or to a conductive fill pipe. High charge generation rates can also occur when liquids are mixed, thinned, tinted or agitated.

Methods of Static Control

In addition to being dependent on the charge generation rate, charge accumulation is a function of the resistance of the path by which charges dissipate. Within a liquid, the dissipation of static electricity is dependent on a property of the liquid known as "conductivity". Some flammable liquids have very low conductivities and tend to accumulate static charges. Toluol, an example of such a liquid, has a long history of causing fires. (See Table 1 for conductivity data on some pure liquids from Lange's Handbook)

Although the generation of static electricity cannot be eliminated, its rate of generation and accumulation can be reduced by the following procedures:

- **Piping Systems** - The most effective method of reducing the accumulation of static charges in piping systems is through proper pipe sizing to keep liquid velocities low. A recommended maximum velocity in piping systems is 15 feet per second. Table II lists the flow rates for various pipe sizes for a velocity of 15 feet/sec.
- **Filling Operations** - Splash filling and free-fall of flammable liquids should be eliminated to the maximum extent practical by lowering fill velocities, by providing diverters to direct the discharge of liquid down the side of the grounded vessel being filled, or by submerging fill pipes below the liquid level in the vessel. Submerging of fill pipes in paint manufacturing vessels may not always be practical. In bulk-filling operations the velocity of the incoming liquid should not exceed 3 feet per second until the pipeoutlet is covered; the velocity may then be increased to the 15 feet per second maximum mentioned previously. Table II also lists the flow rates for various pipe size for the velocity of 3 feet per second.
- **Filtration** - Experience has shown that this hazard maybe controlled by installing filters far enough upstream of discharge points to provide a 30 second liquid relaxation time prior to discharge. The required relaxation time depends upon the conductivity, the liquid velocity, and the type of filter. For example, the 30 second relaxation time may not be necessary with a highly conductive liquid.
- **Dispersing Operations** - For dispersing operations, the conductivity of the liquid should be raised¹, if necessary, to above 2000 conductivity units (C.U.) (2×10^{-5} micromho/cm) before particulates are added. If possible, polar solvents should be added before non-polar solvents or particulates are added. Polar solvents are more conductive than non-polar solvents. In some instances, proprietary anti-static agents, developed for use with fuels, can be used as additives to reduce the charge accumulation. Typically, only a few parts per million of the additive are required. Tests should be run to ensure that the conductivity additive does not cause formulation problems. The additive may not be suitable for use in coatings for food containers.

¹If the conductivity cannot be raised to the recommended value, the vessel should be inerted. Pebble mills present an additional hazard because their porcelain lining is an insulator that will prevent the flow of static charges from liquid to ground, even if the mill is grounded. This hazard is best controlled by inerting the mill. The rate of charge dissipation on most solid surfaces can be increased by raising the humidity. It should be noted that the static accumulation in liquids cannot be controlled by raising the ambient humidity.

TABLE I

Liquid	(°C) Temperature	Micromhos/cm	(C.U.) Conductivity Units	Liquid	(°C) Temperature	Micromhos/cm	(C.U.) Conductivity Units
Acetadehyde	15	1.7	1.7 x 10 ⁸	Ethylene bromide	19	2 x 10 ⁻⁴	2 x 10 ⁴
Acetic Acid	25	1.1 x 10 ⁻²	1.1 x 10 ⁸	Ethylene chloride	25	3 x 10 ⁻²	3 x 10 ⁸
Acetic anhydride	25	4.8 x 10 ⁻¹	4.8 x 10 ⁷	Ethyl ether	25	<4 x 10 ⁻⁷	<4 x 10 ¹
Acetone	25	6 x 10 ⁻²	6 x 10 ⁸	Ethyl isothiocyanate	25	1.3 x 10 ⁻¹	1.3 x 10 ⁷
Acetonitrile	20	7	7 x 10 ⁸	Ethyl nitrate	25	5.3 x 10 ⁻¹	5.3 x 10 ⁷
Acetophenone	25	6 x 10 ⁻³	6 x 10 ⁵	Ethyl thiocyanate	25	1.2	1.2 x 10 ⁸
Acetyl bromide	25	2.4	2.4 x 10 ⁸	Formamide	25	4	4 x 10 ⁸
Acetyl chloride	25	4 x 10 ⁻¹	4 x 10 ⁷	Formic acid	25	6.4 x 10 ¹	7.4 x 10 ⁹
Allyl alcohol	25	7	7 x 10 ⁷	Furfural	25	1.5	1.5 x 10 ⁸
Aniline	25	2.4 x 10 ⁻²	2.4 x 10 ⁸	Glycerol	25	6.4 x 10 ⁻²	6.4 x 10 ⁶
Benzaldehyde	25	1.5 x 10 ⁻¹	1.5 x 10 ⁷	Glycol	25	3 x 10 ⁻¹	3 x 10 ⁷
Benzene (benzol)	-	7.6 x 10 ⁻²	7.6 x 10 ⁶	Heptane	-	<1 x 10 ⁻⁷	<1 x 10 ¹
Benzoic acid	125	3 x 10 ⁻³	3 x 10 ⁵	Hexane	18	1 x 10 ⁻¹⁰	1 x 10 ⁻²
Benzonitrile	25	5 x 10 ²	5 x 10 ⁸	Keroscene	25	1.7 x 10 ⁻²	1.7 x 10 ⁶
Benzyl alcohol	25	1.8	1.8 x 10 ⁸	Methyl acetate	25	3.4	3.4 x 10 ⁸
Bromobenzene	25	<2 x 10 ⁻⁵	<2 x 10 ³	Methyl alcohol	18	4.4 x 10 ⁻¹	4.4 x 10 ⁷
Butyl alcohol	25	1 x 10 ⁻²	1 x 10 ⁶	Methyl ethel keytone	25	1 x 10 ⁻¹	1 x 10 ⁷
Carbon disulphide	1	7.8 x 10 ⁻⁶	7.8 x 10 ²	Methylisobutylkeytone	-	6.7 x 10 ⁻²	6.7 x 10 ⁶
Carbon tetrachloride	18	5 x 10 ⁻¹²	5 x 10 ⁻⁴	Methyl nitrate	25	1.5	1.5 x 10 ⁸
Cyclohexanone	-	5 x 10 ⁻³	5 x 10 ⁵	Naptha, VM&P, EC	-	<1.3 x 10 ⁻⁷	<1.3 x 10 ¹
Dichloroacetic acid	25	1.2 x 10 ⁻¹	1.2 x 10 ⁷	Naphthalene	82	4 x 10 ⁻⁴	4 x 10 ⁴
Dichloroethylene	-	1.7 x 10 ⁻²	1.7 x 10 ⁸	Nitroberizene	0	5 x 10 ³	5 x 10 ⁵
Diethyl amine	-33.5	2.2 x 10 ⁻³	2.2 x 10 ⁵	Nitromethane	18	6 x 10 ⁻¹	6 x 10 ⁷
Diethyl carbonate	25	1.7 x 10 ⁻²	1.7 x 10 ⁶	Petroleum	-	3 x 10 ⁻⁷	3 x 10 ¹
Diethyl oxalate	25	7.6 x 10 ⁻¹	7.6 x 10 ⁷	Phenol	25	1 x 10 ⁻²	1 x 10 ⁶
Diethyl sulfate	25	2.6 x 10 ⁻¹	2.6 x 10 ⁷	n-Propyl alcohol	18	5 x 10 ⁻²	5 x 10 ⁶
Dimethyl acetamide	-	1.1 x 10 ⁻¹	1.1 x 10 ⁷	iso-Propyl alcohol	25	3.5	3.5 x 10 ⁸
Dimethyl sulfate	0	1.6 x 10 ⁻¹	1.6 x 10 ⁷	Sulfuric acid	25	1 x 10 ⁴	1 x 10 ¹²
Epichlorohydrin	25	3.4 x 10 ⁻²	3.4 x 10 ⁶	Toluene	-	<1 x 10 ⁻⁸	<1
Ethyl acetate	25	1 x 10 ⁻³	1 x 10 ⁵	Trichloric acid	25	3 x 10 ⁻³	3 x 10 ⁵
Ethyl acetoacetate	25	4 x 10 ⁻²	4 x 10 ⁶	Trimthylamine	-33.5	2.2 x 10 ⁻⁴	2.2 x 10 ⁴
Ethyl alcohol	25	1.3 x 10 ⁻³	1.3 x 10 ⁵	Turpentine	-	2.2 x 10 ⁻⁷	2.2 x 10 ¹
Ethyl amine	0	4 x 10 ⁻¹	4 x 10 ⁷	Water	18	4 x 10 ⁻²	4 x 10 ⁶
Ethyl bromide	25	2 x 10 ⁻²	2 x 10 ⁶	Xylene	-	<1 x 10 ⁻⁹	<1 x 10 ⁻¹

NOTES

- 1 conductivity unit (C.U.) = 1 picosiemen per meter.
- 1 micromho per cm = 10⁶ C.U.
- 1 mho per cm = 10⁶ micromhos per cm.
- *Conductivity of benzene can vary widely.
- Conductivity values for typical plant solvents can vary, significantly from values given in above table.

FLOW RATES

Schedule 40 Pipe Size Diameter In Inches	Flow Rate GPM at 15 Ft./Sec	Flow Rate GPM at 3 Ft./Sec.
1	40	8
1 1/2	95	19
2	160	31
2 1/2	220	45
3	345	70
3 1/2	460	93
4	595	120

Nonconductive Plastic Containers and Stretch Film

The use of nonconductive, plastic containers in potentially flammable locations may be an ignition hazard in plants. Static charge accumulations on such containers, caused by the transfer of poorly-conductive liquids or solids, or by contact charging, cannot be dissipated by the bonding/grounding system.

Contact ("triboelectric") charging of a nonconductive container in a low humidity environment creates a spark ignition hazard by inducing charges in the liquid in the container. These induced charges may cause sparking, e.g., when the liquid is poured into a grounded safety can. Surprisingly, this hazard of charge induction is greatest when the liquid is "conductive".

Experience suggests the following precautions:

- **Fibre-board drums:** No hazard of static accumulation, except for metal rims, which should be grounded during product transfer.
- **Kraft paper bags and plastic lined paper bags :** No hazard with paper bags. Plastic-lined paper bags are usually not hazardous, but the static electrification for each bag/contents combination should be measured.
- **All-plastic bags and bags with removable plastic liner:** Should be avoided unless measurements of electric field intensity at bag surface during product transfer is less than 5 kV/cm (12.5 kV/inch).
- **Plastic bottles and nonconductive drum liners:** Are subject to the hazard of charge induction as a result of contact electrification. Precautions must be taken to minimize contact charging or to neutralize contact charges before use. Removal of plastic bottles from plastic bags may cause high contact charging. Electric field intensities greater than 5 kV/cm (12.6 kV/inch) at the surface of the bottle or liner should be neutralized before a "conductive" flammable liquid is put into the bottle. It is also important to avoid charging a plastic bottle than contains even a small quantity of a conductive, flammable liquid.
- **Stretch Wrap:** Must be removed from pallets in a nonflammable location. This material is usually highly charged and represents a serious hazard in flammable locations.
- **Semi-bulk "supersacks":** Flexible Intermediate Bulk Containers (FIBC). FIBC's are now categorized into types A, B, C & D. The type C bag contains thin conductive strips spaced closely together in the polypropylene weave. All strips are interconnected at the seams and via the lifting handles and labeled ground point. These conductive parts are designed to carry away any static electricity from the powders within. Type C bags have been proved to be safe for use in flammable atmospheres, providing they have been suitably grounded using a discharge lead and clamp.
- **Conductive plastic liners and containers:** Although most plastic materials are nonconductive, some conductive plastic liners and containers are now commercially available. Conductive plastic materials must be grounded during product transfer in flammable locations.

Bonding and Grounding Principles

Bonding and grounding is a very effective technique for minimizing the likelihood of an ignition from static electricity.

A **Bonding** system connects various pieces of conductive equipment together to keep them at the same potential. Static sparking cannot take place between objects that are the same potential.

Grounding is a special form of bonding in which conductive equipment is connected to an earthing electrode or to the building grounding system in order to prevent sparking between conductive equipment and grounded structures.¹

In potentially-flammable locations, all conductive objects that are electrically isolated from ground by nonconductors such as nonconductive piping or hoses, flexible hoses, flexible connections, equipment supports, or gaskets, should be bonded. An isolated, conductive object, can become charged sufficiently to cause static spark. Objects which can become isolated include screens, rims of nonconductive drums, probes, thermometers, spray nozzles, and high pressure cleaning equipment.

Bonding and grounding cables must be durable and of low resistance. Connections of bonding conductors to process equipment must be direct and positive for portable equipment, uninsulated copper or stainless steel, aviation-type flexible cable and single-point clamps, should be used. These clamps will make contact with metal surfaces through most paint, rust and surface contaminants. The single-point clamps are superior to the battery-type and "alligator" type clamps for making direct contact.

This bulletin contains drawings of typical arrangements of bonding and grounding devices which should be used wherever solvents are handled. The large size of bonding and grounding cables is selected for minimizing mechanical damage rather than for current-carrying capacity. These cables carry microampere-level electrical currents. An arbitrary value of maximum resistance (e.g., 25 ohms) from each bonded object to the grounding bus is specified so that periodic checks of the bonding/grounding system with a simple ohmmeter can confirm that the system is intact and in direct contact with the bonded objects.

Caution must be exercised in the installation of static grounding systems not to use as a ground, any part of the electrical current-carrying system. Fires caused by electrical arcing from current feedback through the grounding system have occurred in plants where static-control grounds were tied into the electrical systems neutrals.

Inerting Methods and Procedures

The introduction of an inert gas such as nitrogen into a ball or pebble mill or mixer will prevent a flash fire if an electrostatic spark occurs within a vessel. Care must be exercised that sufficient inert gas is introduced to adequately displace the oxygen throughout the entire vessel. The most common inert gases are nitrogen and carbon dioxide (CO₂).

Two important considerations, when inerting, are gas pressure and gas velocity. High gas pressure could damage a closed vessel. To avoid overpressurization, a relief valve is recommended on the gas line to the mill.

Inerting with carbon dioxide is potentially hazardous, and such systems must be carefully designed and installed. A CO₂ fire extinguisher should never be used to inert a vessel.

Continuous automatic inerting systems are designed specifically for the coatings industry. These systems monitor the oxygen content in any mixing vessel and adjust the flow of inert gas to maintain a nonflammable environment within the vessel. This inerting method can be used in high speed dispersers as well as in ball and pebble mills.

The section on "Inert Gas Systems" of NFPA 77, "Explosion Prevention Systems," published by the National Fire Protection Association, discusses various factors involved in using inert gas. (Refer to Appendix A of NFPA 77.)

¹In order to successfully achieve this objective of the same ground potential for all metal objects when there are additional and/or redundant grounding systems, and particularly when there are supplementary grounding electrodes, all such grounding systems and electrodes should be connected together as required by the National Electrical Code, and by the NFPA Lighting Protection Code.

Testing and Inspection of Bonding/Grounding systems

The proper installation of bonding and grounding devices is important in the protection of personnel and equipment. At the time of installation a resistance test is needed to confirm electrical continuity to ground. In addition, an effective inspection and maintenance program is needed to ensure continuity adequacy of the system.

In evaluating maintenance requirements, the bonding and grounding system can be divided into three categories:

- The point-type clamps equipped with flexible leads used for temporary bonding of portable containers to the building grounding system.
- The fixed grounding cables and bus bars used to connect the flexible leads and fixed equipment to ground.
- The earthing electrode itself.

The flexible leads are subject to mechanical damage and wear, as well as corrosion and general deterioration. For this reason they should be inspected frequently. This inspection should evaluate cleanliness and sharpness of the clamp points, stiffness of the clamp springs, evidence of broken strands in the cables, and solidity of cable attachments. A more thorough inspection should be made regularly, using an intrinsically-safe ohmmeter to test ohmic resistance and continuity.

One lead of the ohmmeter is connected to a clean spot on the container, the other lead is connected to the paint grounding bus, metallic piping, or other fixed equipment. The measured resistance should be less than 25 ohms, and will usually be about one ohm.

The fixed leads and the bus bars are not usually as subject to injury or wear as the temporary connectors. These should be checked with an ohmmeter on an annual basis. One lead of the ohmmeter should be connected to the fixed lead or bus bar, the other lead should be connected to the plant earthing electrode or to the structural steel of the building. The measured resistance should be less than one ohm.

Conductive hoses should be checked regularly, and after repair or replacement, for electrical continuity and resistance. The conductive segments may break and may not be repaired properly, thus rendering the hoses nonconductive or with an abnormally high resistance. Nonconductive hoses having an internal, spiral conductor should be installed so that the spiral conductor makes contact with adjacent metallic fittings.

Earthing Electrodes

The final component of the bonding/grounding system is the "earthing electrode" which passes static charges into the soil. This may be a device installed solely for grounding purposes, such as a *driven rod* (copper clad) or buried plate, or it may be an underground metal water pipe. If the building has a steel structure frame that is grounded for lighting protection or is otherwise effectively grounded, this grounding is adequate for static grounding; no separate static earthing electrode is needed.

Underground piping equipped with cathodic protection is not a suitable ground. Underground piping made of cement-asbestos or plastic would not be satisfactory as a ground. It is also possible for metal piping to have sections of plastic or cement-asbestos which would make it unsatisfactory. Water meters should have jumper cables permanently installed around them to provide a continuous electrical path. When underground piping is utilized as a ground, any disconnections for alterations or repair may make the grounding system ineffective.

Sprinkler piping and electrical conduit should be avoided because of the increased resistance to ground caused by joints and connectors. A break in continuity can also result when piping and conduit are removed for repair or alterations.

Grounding Verification Control System

Properly labeled "The Invisible Enemy", static electricity cannot be seen but poses extreme risks if not properly attended to. Yet we rely on a visual means to confirm that a ground clamp and lead are in place for proper grounding or bonding, with periodic confirmation via resistance meters. Newer "electronic verification systems" now take the guesswork out of proper grounding techniques. These verification systems offer a continuous means of visual/electronic confirmation of ground to a high-integrity ground point (ground bus). Through "interlock" functions they can control pumps, valves, motors, etc. or interface with a PLC or DCS control system to ensure that nothing happens until a good ground is achieved. They may also initiate sound alarms if required. Further information on the various systems can be found in this booklet.

Drawings of Typical Arrangements for Grounding

Drawing	Item
TA-1	Ground Connection of building Ground Bus
TA-2	Permanent-Fixed, Equipment Ground Extension to Building Ground "bus"
TA-3	Small Ground Clamp
TA-4	Large Ground Clamp
TA-5	Building Ground "Bus" Extension to Portable Solvent Containers
TA-6	Grounding "Tap" Connection to Building Ground "Bus"
TA-7	Typical Arrangement - Grounding of Portable "Material Transfer Chute"
TA-8	Pipe Grounding Jumper
TA-9	Pipe Grounding Clamp
TA-10	Typical Grounding Arrangement at "Drop Valve" of Thinning or Mixing Tank
TA-11	Typical Grounding Arrangement of Laboratory Mixing Unit
TA-12	Typical Grounding System Standard Arrangement at Thinning or Mixing Equipment
TA-13	Typical Grounding System for Small Volume Solvent Handling
TA-14	Typical Grounding System for Small Volume Solvent Handling
TA-15	Typical Small Change Can Grounding Arrangement for Solvent Handling
TA-16	Typical Portable Tank and Drum Transfer Area Static Grounding Arrangement
TA-17	Typical Grounding System for Small Volume Solvent Handling
TA-18	Typical Arrangement for Static Grounding of 55 Gallon Drums in Storage Rack
TA-19	Ground Verification, Drums and Totes
TA-20	Ground Verification, Fiber Bags
TA-21/22	Ground Verification, Railcar and Tanker Cars
TA-23	Typical Tank Car or Truck Loading/Unloading Grounding Arrangement

The drawings shown in this book are approved concepts. If there is any question regarding local fire codes, check with your Fire Marshall.

Static Electricity is always present in your plant...

The chances of static build-up to spark explosions, costly fires, property damage and injury to workers are a constant danger; any industrial process will generate static electricity.

Grounding is the approved and best way to drain off static charges. You can eliminate static accumulation with the use of **Browne** Bonding/Grounding Clamps and conductive wiring.

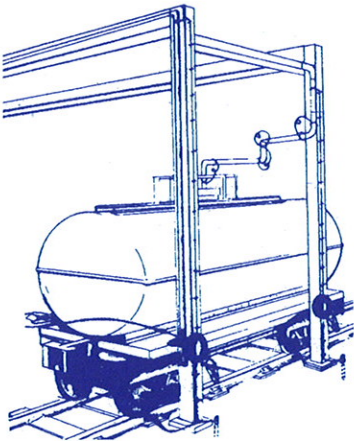

Our clamps are the plier type with sharp, replaceable points. Strong, long-lasting spring enables points to penetrate all paint, rust, etc. You must have bare metal contact to be able to draw off static electricity. The use of **Browne** ground clamps will allow you to comply with OSHA Standards.

While OSHA does not prescribe how, it does dictate when and where static grounding and bonding procedures must exist. For instance, when unloading or loading bulk carriers such as tank cars or tank trucks or transferring flammables in small containers, the following sections apply.

Sec. 1910.106(f)(3)(iv) (a, b&c) Static Protection.

- (a) Bonding facilities for protection against static sparks during the loading of tank vehicles through open domes shall be provided:
- (1) Where Class I liquids are loaded, or
 - (2) Where Class II liquids or Class III liquids are loaded into vehicles which may contain vapors from previous cargoes of Class I liquids
- (b) Protection as required in (a) of this subdivision (iv) shall consist of a metallic bond wire permanently electrically connected to the fill stem or to some part of the rack structure in electrical contact with the cargo tank of the tank vehicle.
- (c) Such bonding connection shall be made fast to the vehicle or tank before dome covers are raised and shall remain in place until filling is completed and all dome covers have been closed and secured.

Sec. 1910.106(e)(6)(ii) Grounding and Sec. 1910.106(f)(3)(vi) Container Filling Facilities.

Class I liquids shall not be dispensed into containers unless the nozzle and container are electrically interconnected. Where the metallic floorplate on which the container stands while filling is electrically connected to the fill stem or where the fill stem is bonded to the container during filling operations by means of a bond wire, the provisions shall be deemed to have been complied with.



Sec. 1910.107(e)(9) Grounding.

Whenever flammable or combustible liquids are transferred from one container to another, both containers shall be effectively bonded and grounded to prevent discharge sparks of static electricity.

The preceding Standards will provide reasonable assurance that static electricity can be reduced. However, it must again be remembered that no ground or bond will be effective unless it has continuity. This continuity must be checked at time of installation and quarterly thereafter.

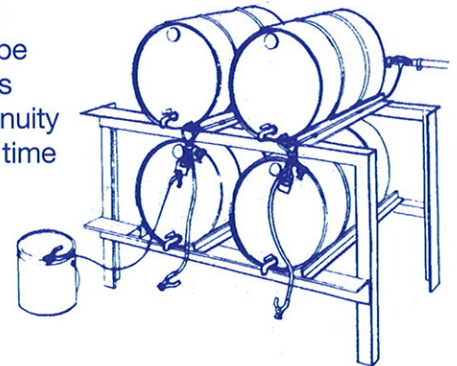

#1/0-1/2 STRANDED, BARE COPPER WIRE BUILDING STATIC GROUNDING "BUS" TYPICAL ARRANGEMENT ROUTED AS CLOSE TO GROUNDING POINT AS POSSIBLE.

ALTERNATE GROUND CAN BE BUILDING COLD WATER PIPE (SHALL BE "MAIN" PIPE OF AREA AND NOT EXTENSION OF "MAIN")

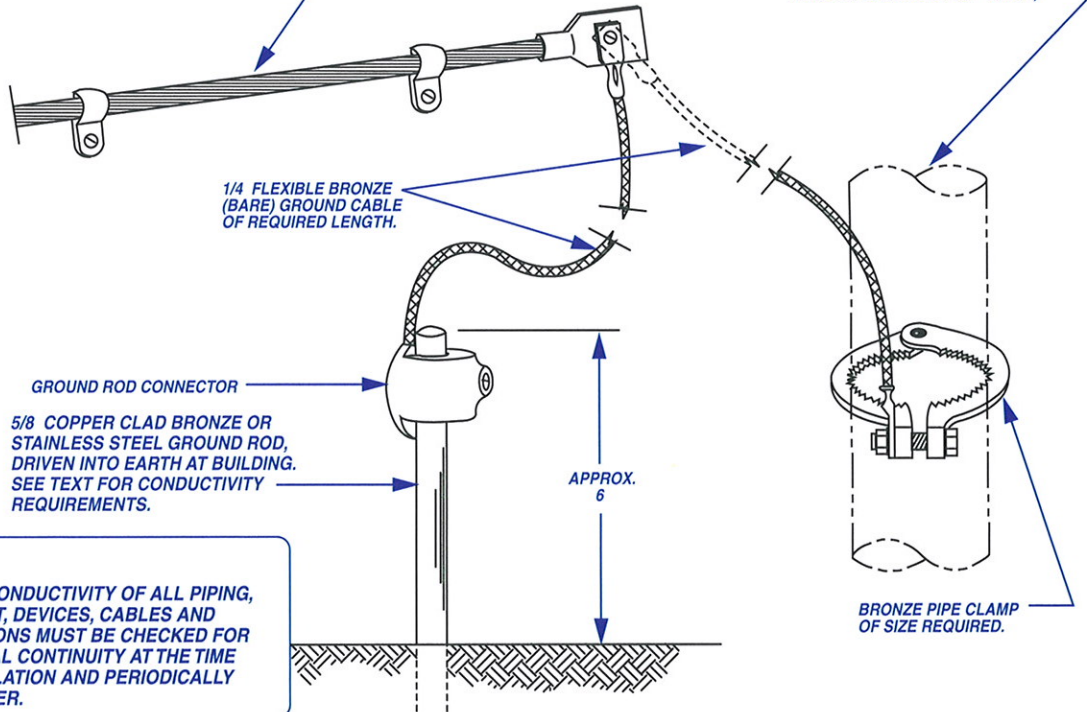

NOTE:

GROUND CONDUCTIVITY OF ALL PIPING, EQUIPMENT, DEVICES, CABLES AND CONNECTIONS MUST BE CHECKED FOR ELECTRICAL CONTINUITY AT THE TIME OF INSTALLATION AND PERIODICALLY THEREAFTER.

GROUND CONNECTION OF BUILDING GROUND BUS - TYPICAL ASSEMBLY

TA-1

TYPICAL ASSEMBLY NO.1

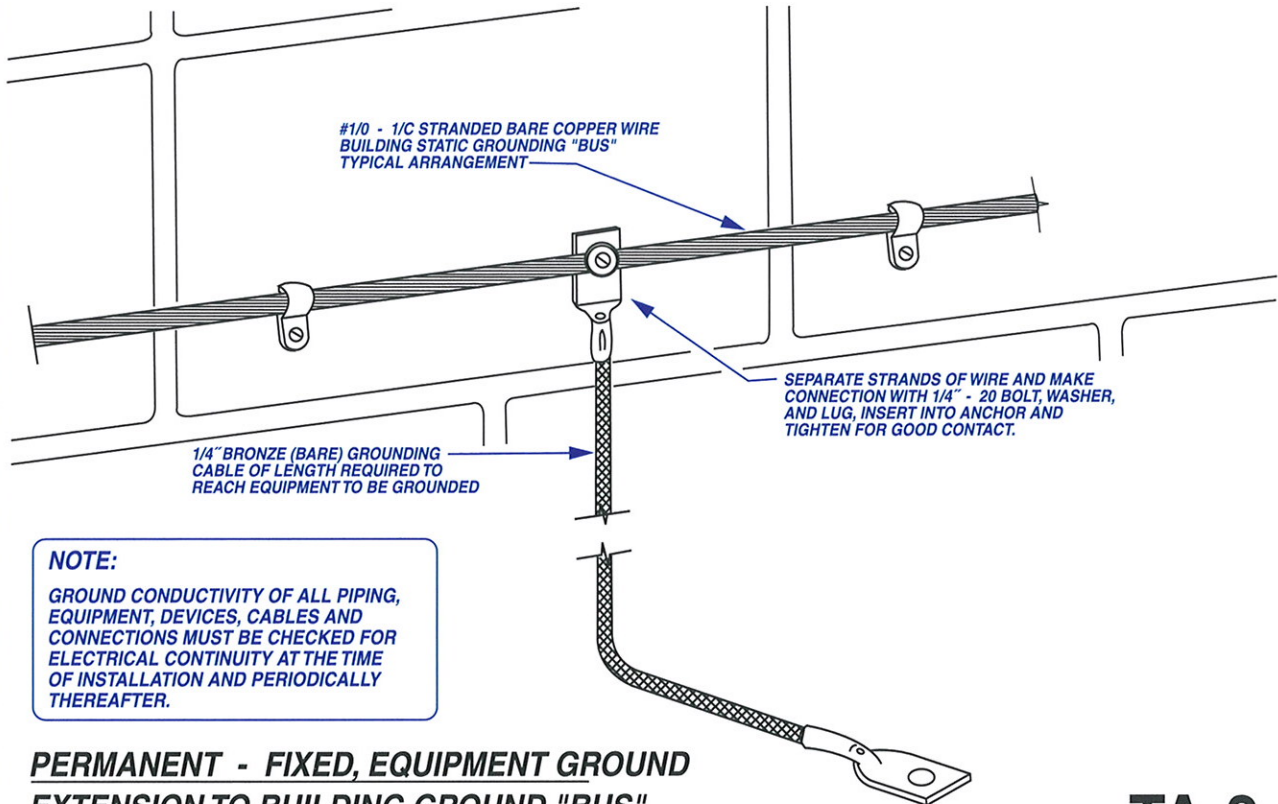

NOTE:

GROUND CONDUCTIVITY OF ALL PIPING, EQUIPMENT, DEVICES, CABLES AND CONNECTIONS MUST BE CHECKED FOR ELECTRICAL CONTINUITY AT THE TIME OF INSTALLATION AND PERIODICALLY THEREAFTER.

PERMANENT - FIXED, EQUIPMENT GROUND EXTENSION TO BUILDING GROUND "BUS" TYPICAL ASSEMBLY

TA-2

TYPICAL ASSEMBLY NO.2

INSERT CABLE END INTO CLAMP AND TIGHTEN LOCKING SCREW UNTIL CABLE AND CLAMP ARE SECURELY LOCKED TOGETHER. DO NOT USE SOLDER OR HEAT FOR THIS CONNECTION.

NOTE:

GROUND CONDUCTIVITY OF ALL PIPING, EQUIPMENT, DEVICES, CABLES AND CONNECTIONS MUST BE CHECKED FOR ELECTRICAL CONTINUITY AT THE TIME OF INSTALLATION AND PERIODICALLY THEREAFTER.

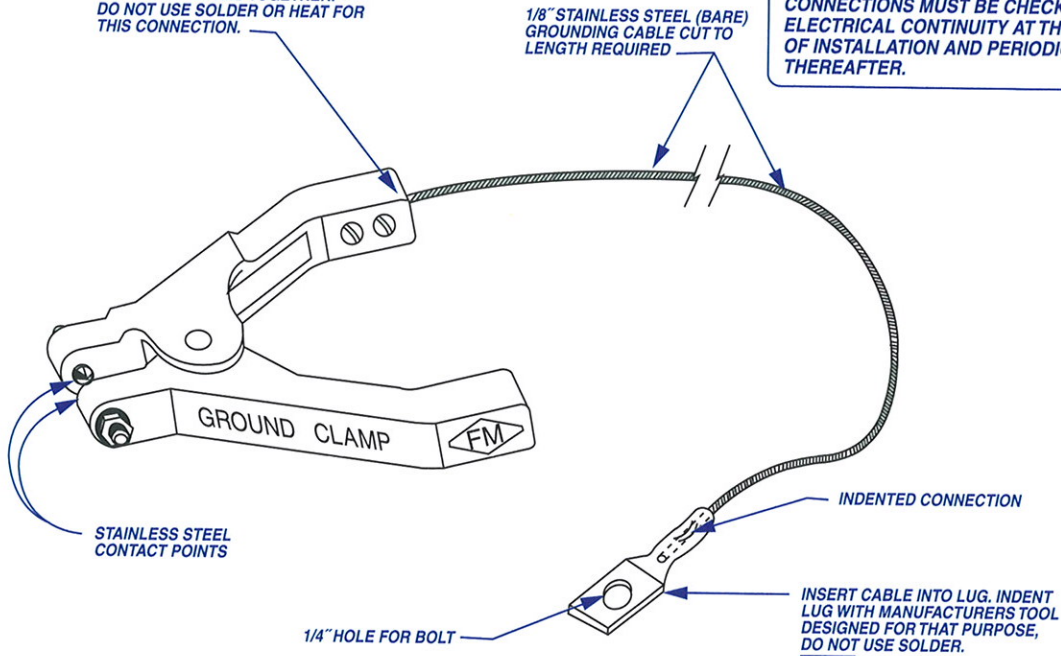

**SMALL GROUND CLAMP
TYPICAL ASSEMBLY**

TA-3
TYPICAL ASSEMBLY NO.3

NOTE:

GROUND CONDUCTIVITY OF ALL PIPING, EQUIPMENT, DEVICES, CABLES AND CONNECTIONS MUST BE CHECKED FOR ELECTRICAL CONTINUITY AT THE TIME OF INSTALLATION AND PERIODICALLY THEREAFTER.

INSERT CABLE END INTO CLAMP AND TIGHTEN LOCKING SCREW UNTIL CABLE AND CLAMP ARE SECURELY LOCKED TOGETHER. DO NOT USE SOLDER OR HEAT FOR THIS CONNECTION.

LARGE CLAMPS USED WITH TANK TRUCKS SHOULD INCLUDE PULLAWAY HARNESS ASSEMBLY.

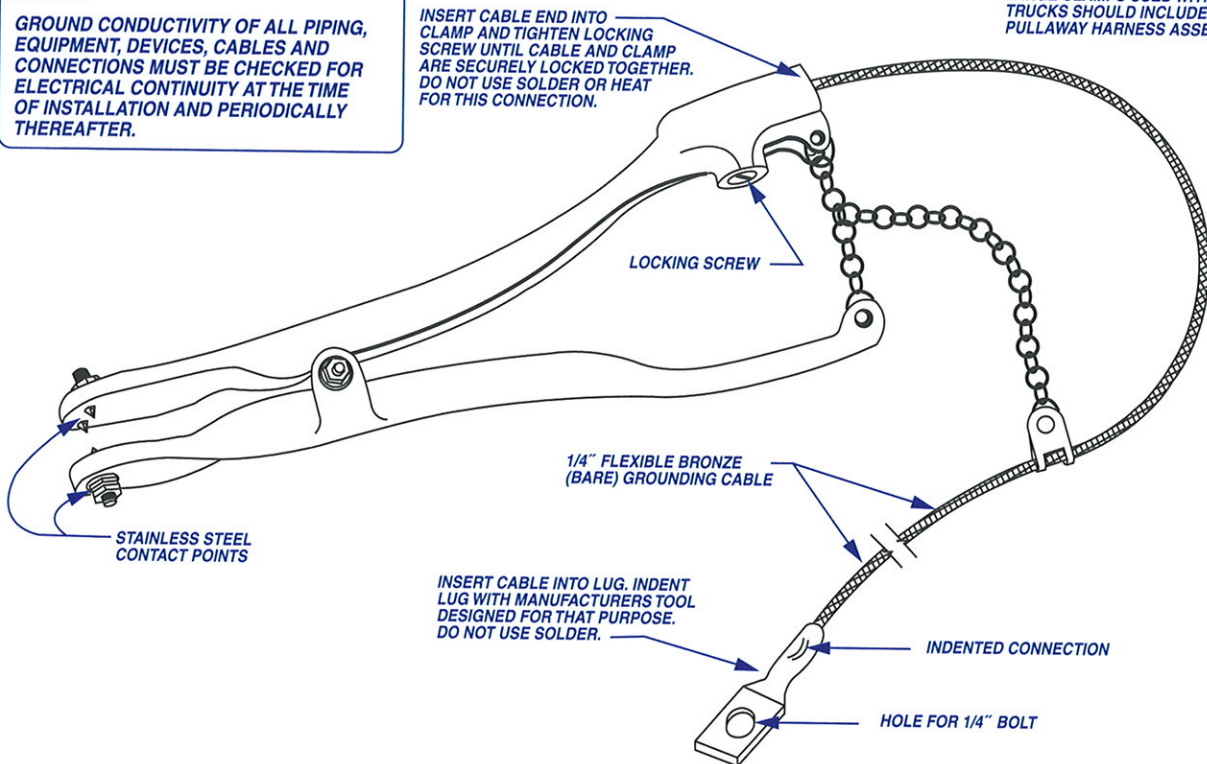

**LARGE GROUND CLAMP
TYPICAL ASSEMBLY**

TA-4
TYPICAL ASSEMBLY NO.4

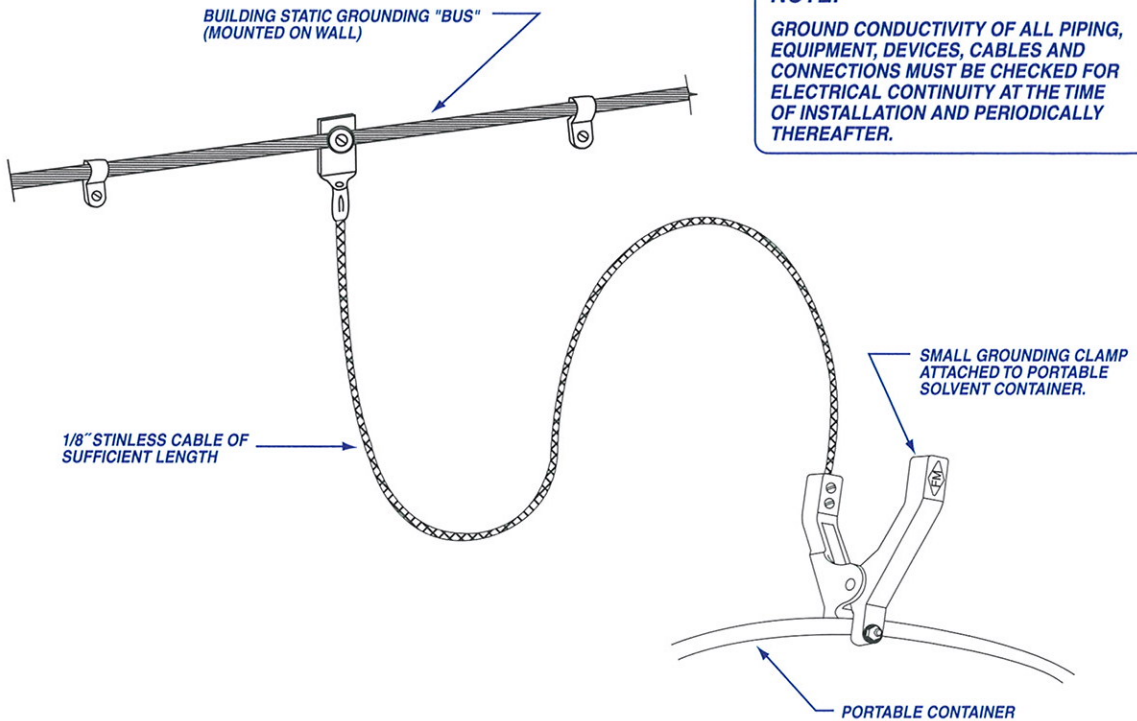

NOTE:
 GROUND CONDUCTIVITY OF ALL PIPING, EQUIPMENT, DEVICES, CABLES AND CONNECTIONS MUST BE CHECKED FOR ELECTRICAL CONTINUITY AT THE TIME OF INSTALLATION AND PERIODICALLY THEREAFTER.

BUILDING GROUND "BUS" EXTENSION TO PORTABLE SOLVENT CONTAINERS TYPICAL ASSEMBLY

TA-5
 TYPICAL ASSEMBLY NO.5

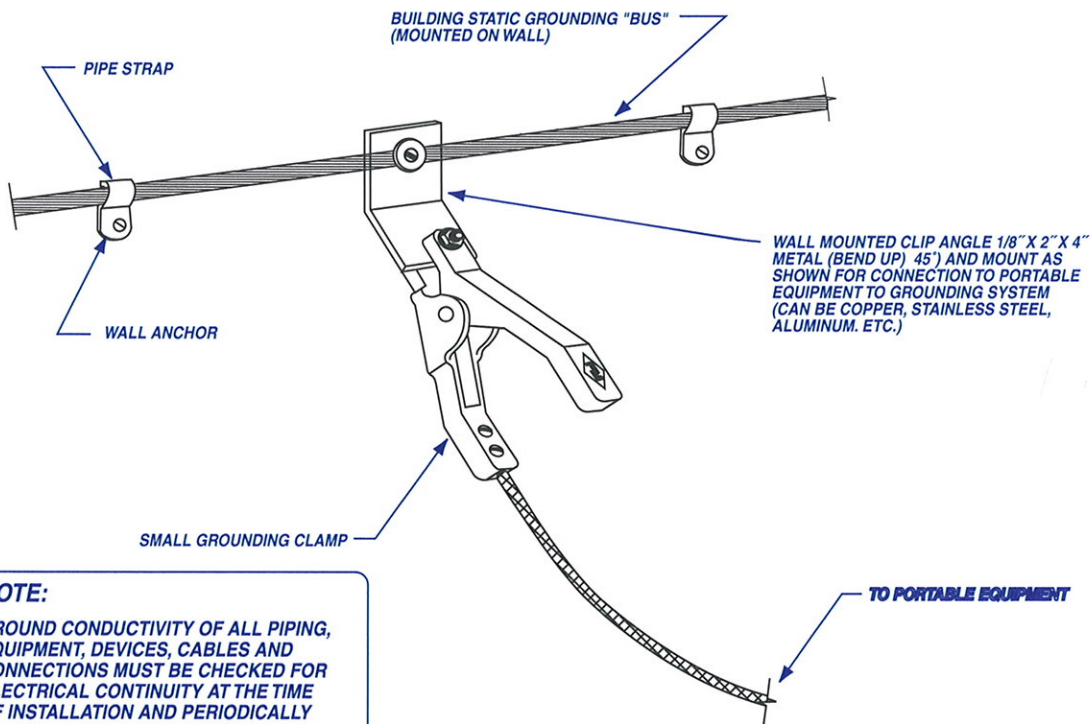

NOTE:
 GROUND CONDUCTIVITY OF ALL PIPING, EQUIPMENT, DEVICES, CABLES AND CONNECTIONS MUST BE CHECKED FOR ELECTRICAL CONTINUITY AT THE TIME OF INSTALLATION AND PERIODICALLY THEREAFTER.

GROUNDING "TAP" CONNECTION TO BUILDING GROUND 'BUS' - TYPICAL ASSEMBLY

TA-6
 TYPICAL ASSEMBLY NO.6

NOTE:

GROUND CONDUCTIVITY OF ALL PIPING, EQUIPMENT, DEVICES, CABLES AND CONNECTIONS MUST BE CHECKED FOR ELECTRICAL CONTINUITY AT THE TIME OF INSTALLATION AND PERIODICALLY THEREAFTER.

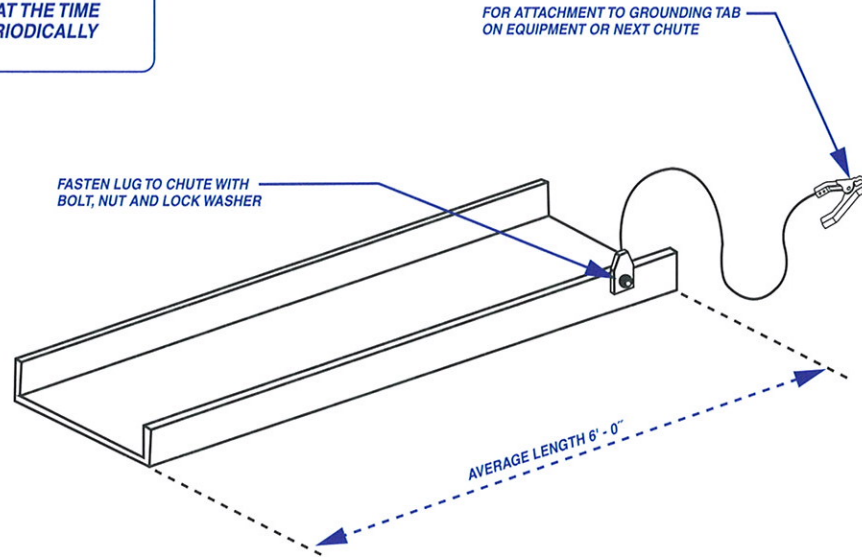

TYPICAL ARRANGEMENT
GROUNDING OF PORTABLE "MATERIAL TRANSFER CHUTE"

TA-7
TYPICAL ASSEMBLY NO.7

NOTE:

GROUND CONDUCTIVITY OF ALL PIPING, EQUIPMENT, DEVICES, CABLES AND CONNECTIONS MUST BE CHECKED FOR ELECTRICAL CONTINUITY AT THE TIME OF INSTALLATION AND PERIODICALLY THEREAFTER.

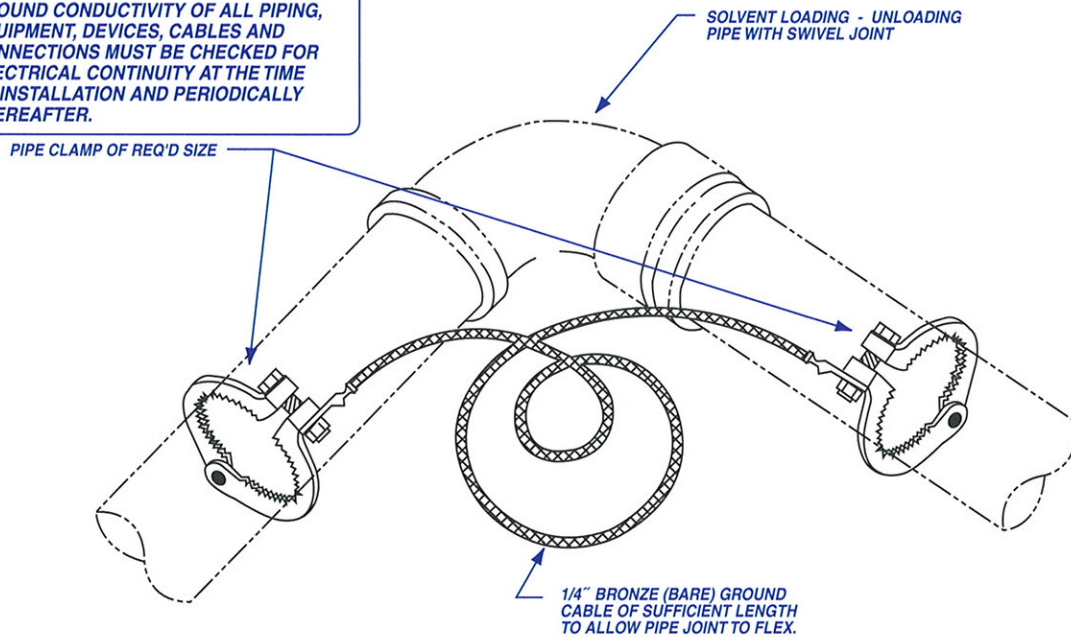

PIPE GROUNDING JUMPER
TYPICAL ASSEMBLY

TA-8
TYPICAL ASSEMBLY NO.8

NOTE:
 GROUND CONDUCTIVITY OF ALL PIPING,
 EQUIPMENT, DEVICES, CABLES AND
 CONNECTIONS MUST BE CHECKED FOR
 ELECTRICAL CONTINUITY AT THE TIME
 OF INSTALLATION AND PERIODICALLY
 THEREAFTER.

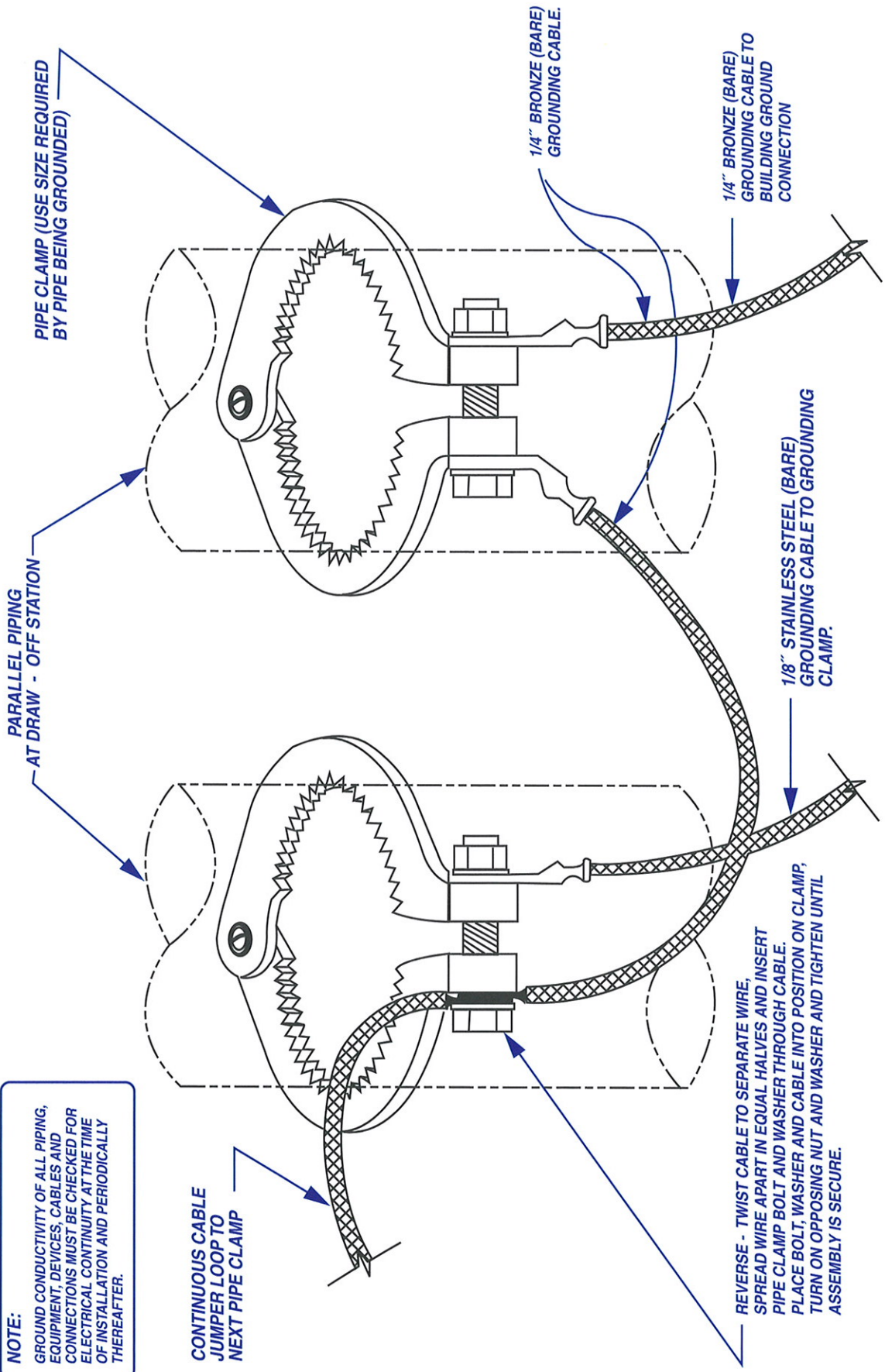

REVERSE - TWIST CABLE TO SEPARATE WIRE,
 SPREAD WIRE APART IN EQUAL HALVES AND INSERT
 PIPE CLAMP BOLT AND WASHER THROUGH CABLE.
 PLACE BOLT, WASHER AND CABLE INTO POSITION ON CLAMP,
 TURN ON OPPOSING NUT AND WASHER AND TIGHTEN UNTIL
 ASSEMBLY IS SECURE.

**PIPE GROUNING CLAMP
 TYPICAL ASSEMBLY**

TA-9
 TYPICAL ASSEMBLY NO.9

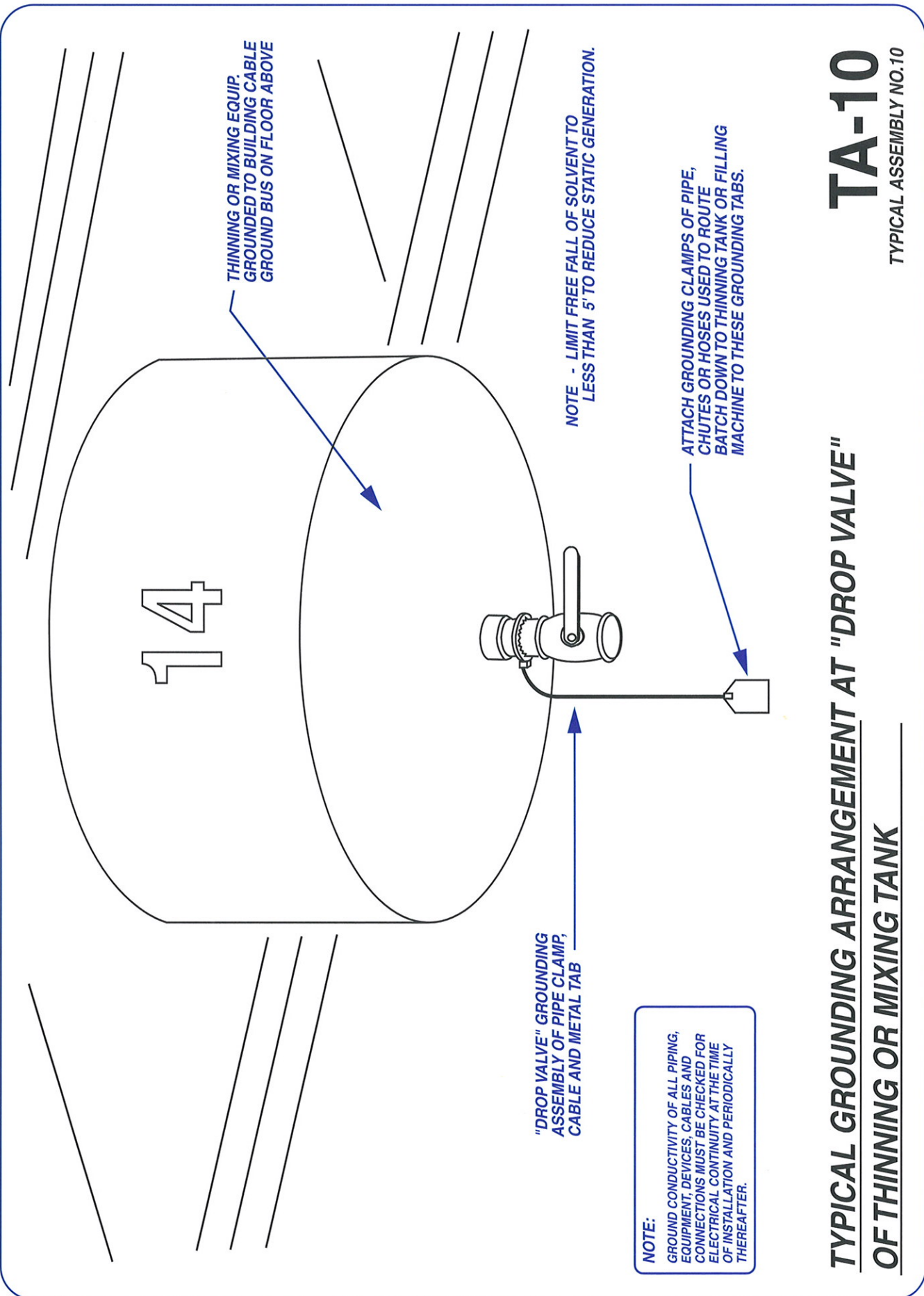

THINNING OR MIXING EQUIP.
 GROUNDED TO BUILDING CABLE
 GROUND BUS ON FLOOR ABOVE

NOTE - LIMIT FREE FALL OF SOLVENT TO
 LESS THAN 5' TO REDUCE STATIC GENERATION.

ATTACH GROUNDING CLAMPS OF PIPE,
 CHUTES OR HOSES USED TO ROUTE
 BATCH DOWN TO THINNING TANK OR FILLING
 MACHINE TO THESE GROUNDING TABS.

"DROP VALVE" GROUNDING
 ASSEMBLY OF PIPE CLAMP,
 CABLE AND METAL TAB

NOTE:
 GROUND CONDUCTIVITY OF ALL PIPING,
 EQUIPMENT, DEVICES, CABLES AND
 CONNECTIONS MUST BE CHECKED FOR
 ELECTRICAL CONTINUITY AT THE TIME
 OF INSTALLATION AND PERIODICALLY
 THEREAFTER.

TA-10
 TYPICAL ASSEMBLY NO.10

**TYPICAL GROUNDING ARRANGEMENT AT "DROP VALVE"
 OF THINNING OR MIXING TANK**

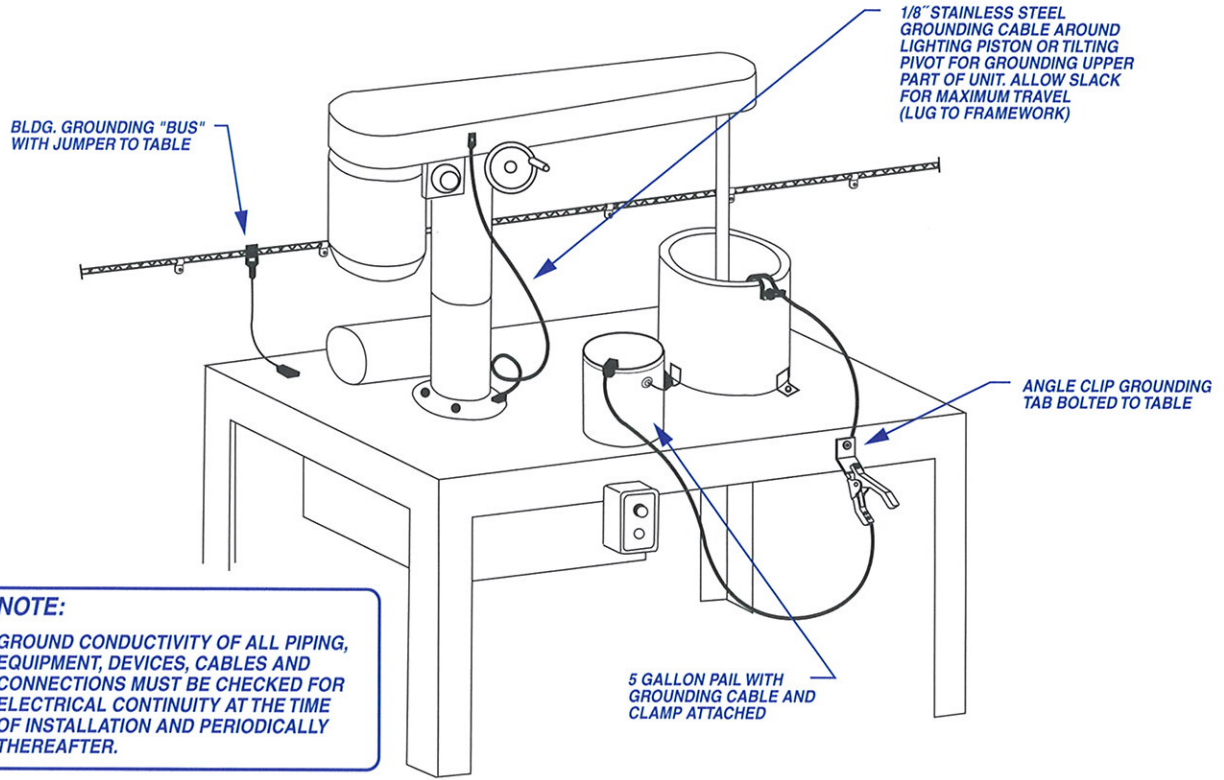

NOTE:
 GROUND CONDUCTIVITY OF ALL PIPING, EQUIPMENT, DEVICES, CABLES AND CONNECTIONS MUST BE CHECKED FOR ELECTRICAL CONTINUITY AT THE TIME OF INSTALLATION AND PERIODICALLY THEREAFTER.

TYPICAL GROUNDING ARRANGEMENT OF LABORATORY MIXING UNIT

TA-11
 TYPICAL ASSEMBLY NO.11

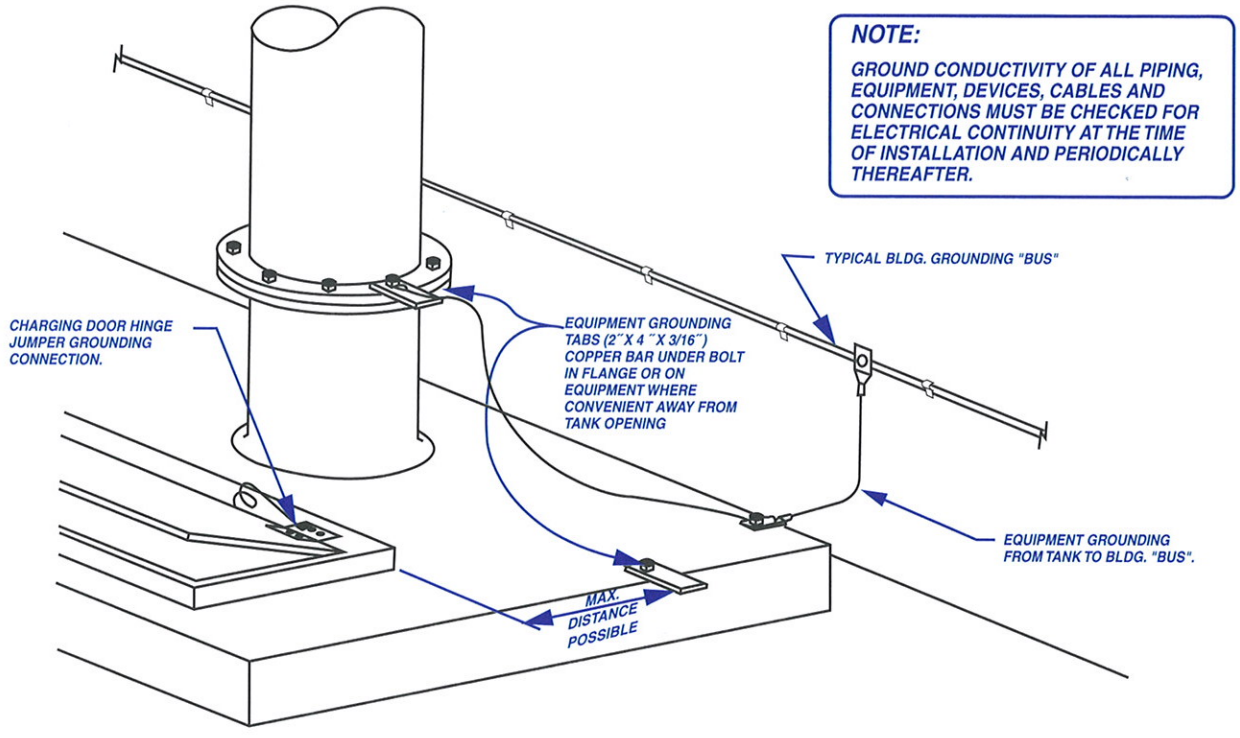

NOTE:
 GROUND CONDUCTIVITY OF ALL PIPING, EQUIPMENT, DEVICES, CABLES AND CONNECTIONS MUST BE CHECKED FOR ELECTRICAL CONTINUITY AT THE TIME OF INSTALLATION AND PERIODICALLY THEREAFTER.

TYPICAL GROUNDING SYSTEM STANDARD ARRANGEMENT AT THINNING OR MIXING EQUIPMENT

TA-12
 TYPICAL ASSEMBLY NO.12

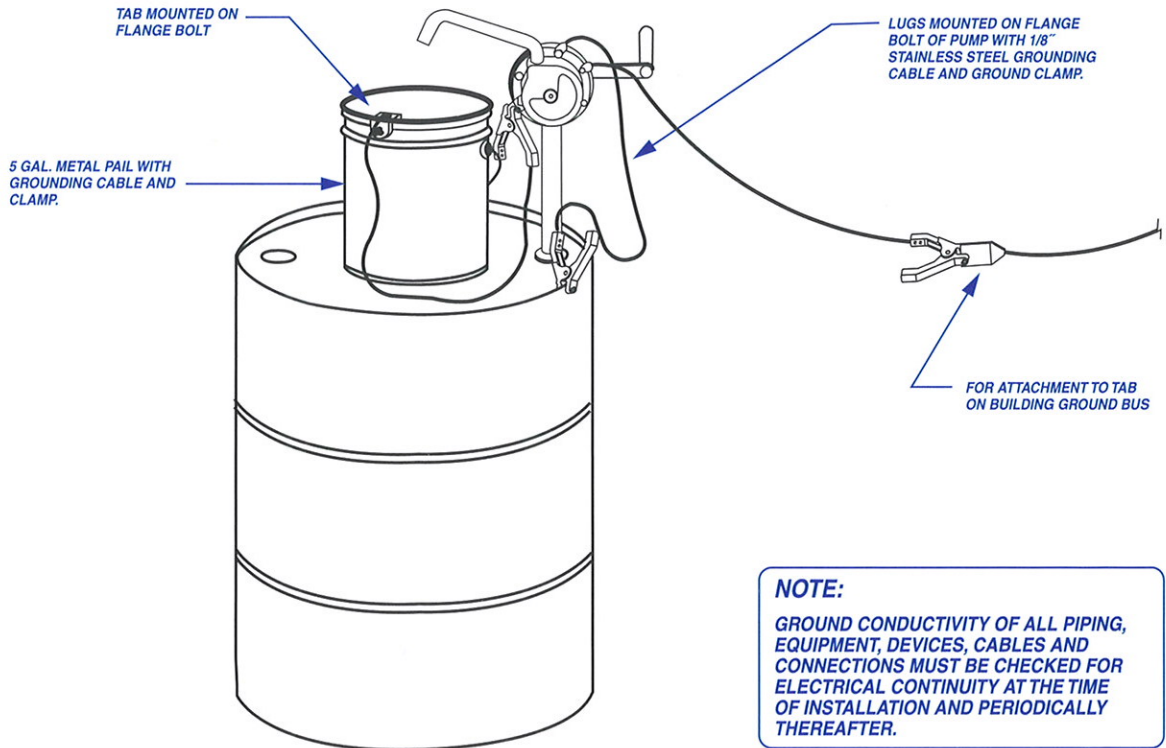

TYPICAL GROUNDING SYSTEM FOR SMALL VOLUME SOLVENT HANDLING

TA-13
TYPICAL ASSEMBLY NO.13

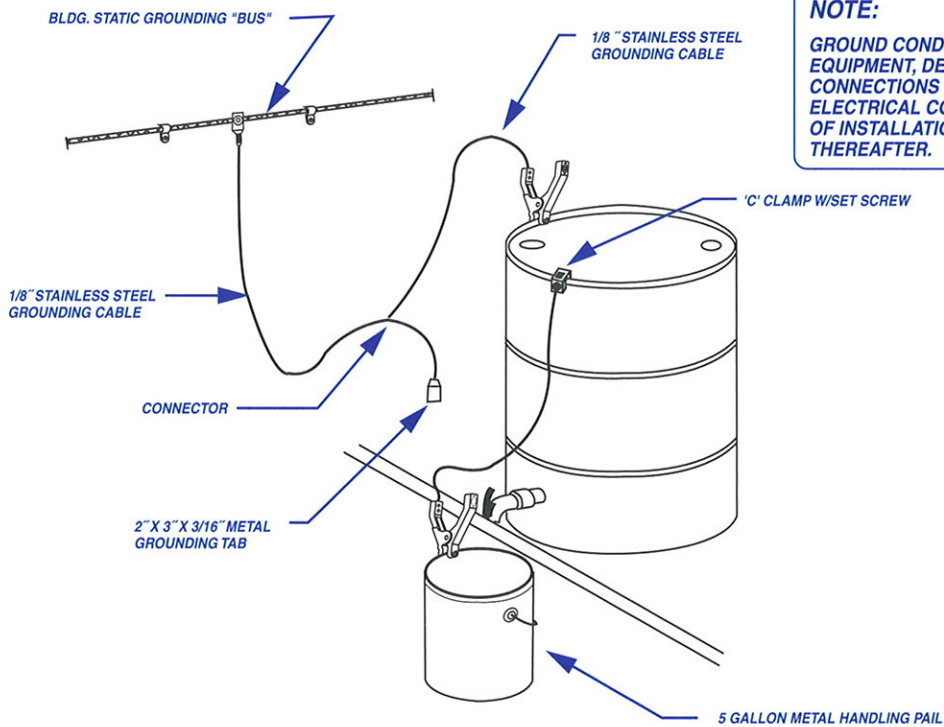

TYPICAL GROUNDING SYSTEM FOR SMALL VOLUME SOLVENT HANDLING

TA-14
TYPICAL ASSEMBLY NO.14

FASTEN LUG WITH
1/4" - 20 BOLT & WASHER

INSULATOR SUPPORT ('C' CLAMP)
TIGHTEN SET SCREW UNTIL GOOD
CONTACT IS MADE WITH PAIL.

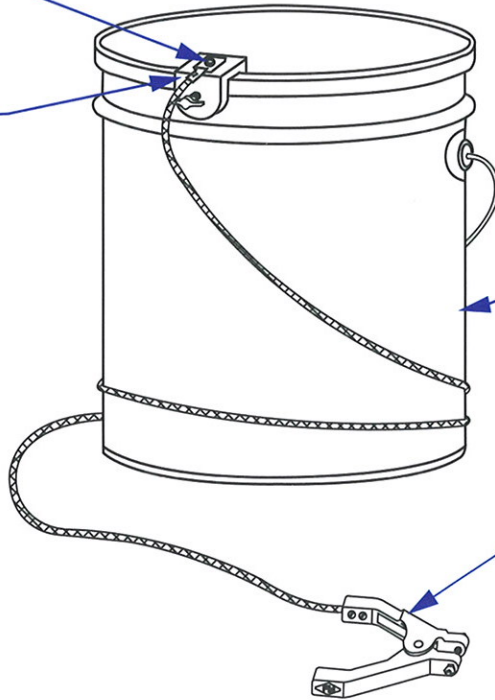

NOTE:
GROUND CONDUCTIVITY OF ALL PIPING,
EQUIPMENT, DEVICES, CABLES AND
CONNECTIONS MUST BE CHECKED FOR
ELECTRICAL CONTINUITY AT THE TIME
OF INSTALLATION AND PERIODICALLY
THEREAFTER.

STANDARD 5 GALLON PAINT CAN,
COATED WITH SPECIAL SOLVENT
RESISTING PAINT OF DISTINCTIVE
RED COLOR. INTERIOR OF
CONTAINER SHALL BE UNCOATED.

STANDARD SMALL GROUNDING CLAMP
AND 5' - 0" LONG CABLE WITH LUG &
CLAMP FOR FASTENING TO CAN

**TYPICAL SMALL CHANGE CAN GROUNDING
ARRANGEMENT FOR SOLVENT HANDLING**

TA-15
TYPICAL ASSEMBLY NO.15

1/0 - 1/C STRANDED WIRE
BUILDING GROUND BUS

STANDARD WALL MOUNTED
GROUNDING TAB

PORTABLE GROUNDING REEL
WITH 20' OR 50' OF 1/8" GALVANIZED
CABLE RATCHET LATCHING

GROUNDING CLAMP

NOTE:
GROUND CONDUCTIVITY OF ALL PIPING,
EQUIPMENT, DEVICES, CABLES AND
CONNECTIONS MUST BE CHECKED FOR
ELECTRICAL CONTINUITY AT THE TIME
OF INSTALLATION AND PERIODICALLY
THEREAFTER.

5 GAL. METAL PAIL
GROUNDING
ARRANGEMENT

**TYPICAL PORTABLE TANK
AND DRUM TRANSFER AREA
STATIC GROUNDING ARRANGEMENT**

TA-16
TYPICAL ASSEMBLY NO.16

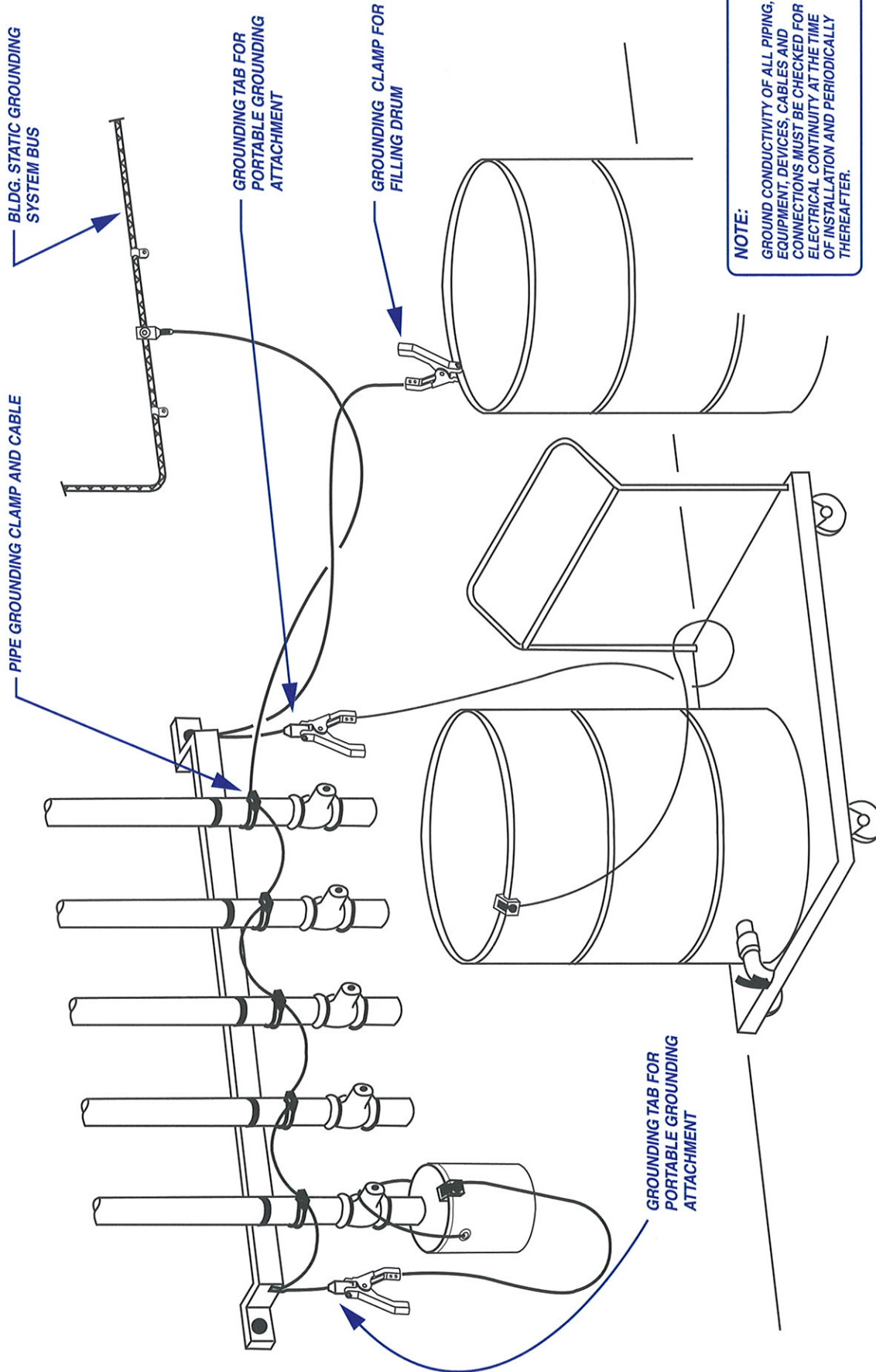

NOTE:
 GROUND CONDUCTIVITY OF ALL PIPING, EQUIPMENT, DEVICES, CABLES AND CONNECTIONS MUST BE CHECKED FOR ELECTRICAL CONTINUITY AT THE TIME OF INSTALLATION AND PERIODICALLY THEREAFTER.

TA-17

TYPICAL ASSEMBLY NO.17

TYPICAL GROUNDING SYSTEM FOR SMALL VOLUME SOLVENT HANDLING

FASTEN GROUND CABLE TO RACK WITH 3/8" ONE HOLE CONDUIT CLAMPS ON 2' - 0" CENTERS

BUILDING GROUND BUS

CLAMP TO DRUM "LIP" AND DRUM RACK

TO BEAM CLAMP ON UPPER DRUM

GROUNDING TAB FOR CONNECTING CLAMPS WHEN TRANSFERRING SOLVENTS

NOTE:
GROUND CONDUCTIVITY OF ALL PIPING, EQUIPMENT, DEVICES, CABLES AND CONNECTIONS MUST BE CHECKED FOR ELECTRICAL CONTINUITY AT THE TIME OF INSTALLATION AND PERIODICALLY THEREAFTER.

NOTE: IMPORTANT!
IDENTICAL GROUNDING ARRANGEMENT REQUIRED FOR EACH PAIR OF DRUMS

"RETRACT - A - CABLE" GROUND ASSEMBLY

METAL CONTAINER

TYPICAL ARRANGEMENT - FOR STATIC GROUNDING OF 55 GALLON DRUMS IN STORAGE RACK

TA-18

TYPICAL ASSEMBLY NO.18

Ground Verification Systems

Electronic monitoring systems are now available to provide visual confirmation of proper ground connection and if required, interface with control functions to provide safe loading processes. All systems are certified for use in hazardous conditions. The following is a sample of systems that are now available.

TA-19

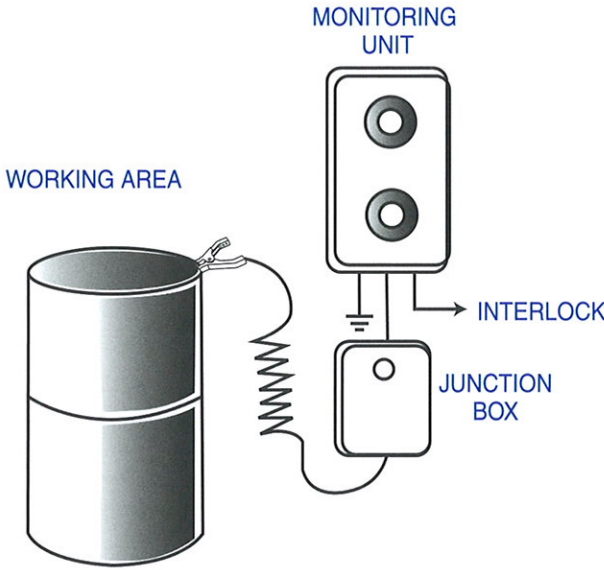

The diagram shows a cylindrical drum or tote in a 'WORKING AREA'. A cable with a spring-loaded probe is connected to the drum. This cable leads to a 'JUNCTION BOX'. From the junction box, one line goes to a 'MONITORING UNIT' which has two circular indicators. Another line from the junction box goes to an 'INTERLOCK' point. The monitoring unit is also connected to a ground symbol.

For Drum & Tote Loading

Provides connection to "high-integrity" ground point. Offers visual "light" display for confirmation of proper ground contact. Units are available to interlock with pumps, valves and motors, or interface with PLC or DCS controls. An optional system is available with battery operated circuitry eliminating the need for field wiring.

TA-20

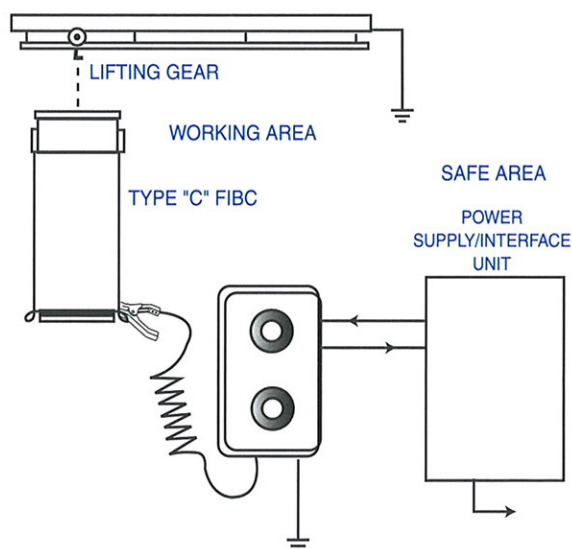

The diagram shows a 'TYPE "C" FIBC' container suspended by 'LIFTING GEAR' in a 'WORKING AREA'. A cable with a spring-loaded probe is connected to the bottom of the container. This cable leads to a 'MONITORING UNIT' with two circular indicators. The monitoring unit is connected to a 'POWER SUPPLY/INTERFACE UNIT' in a 'SAFE AREA'. The monitoring unit is also connected to a ground symbol. The power supply unit has an output line.

For Flexible Intermediate Bulk Containers (FIBC)

Provides connection to "high-integrity" ground point. Tests the bag surface for resistance and offers visual "light" display for confirmation of proper ground contact. Used with material handling of dry powders in bulk form and inconjunction with "Type C" super sacks or large bags.

Ground Verification Systems (cont'd)

TA-21

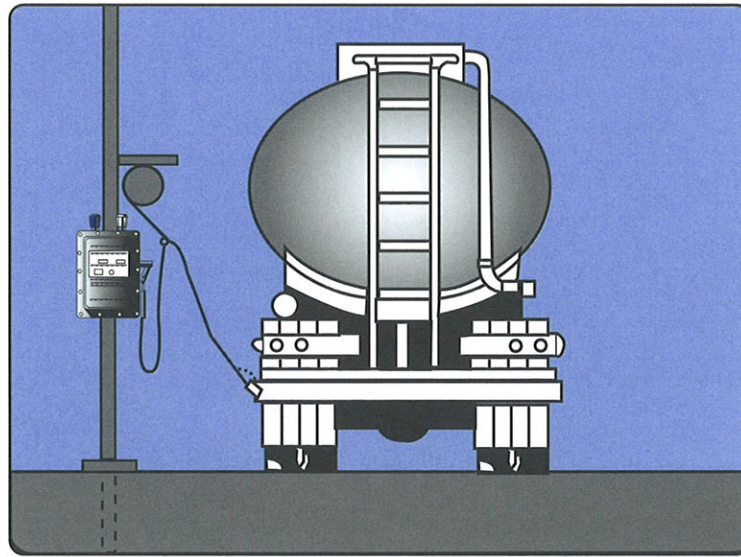

For Tanker Truck Loading

Provides connection to "high-integrity" ground point. Offers visual confirmation of proper ground contact and through "interlocks", can control pumps, valves, motors or interface with PLC or DCS controls. Can also initiate a sound alarm if needed. For road tankers, an optional system is available offering "tanker recognition" in addition to the above mentioned functions.

TA-22

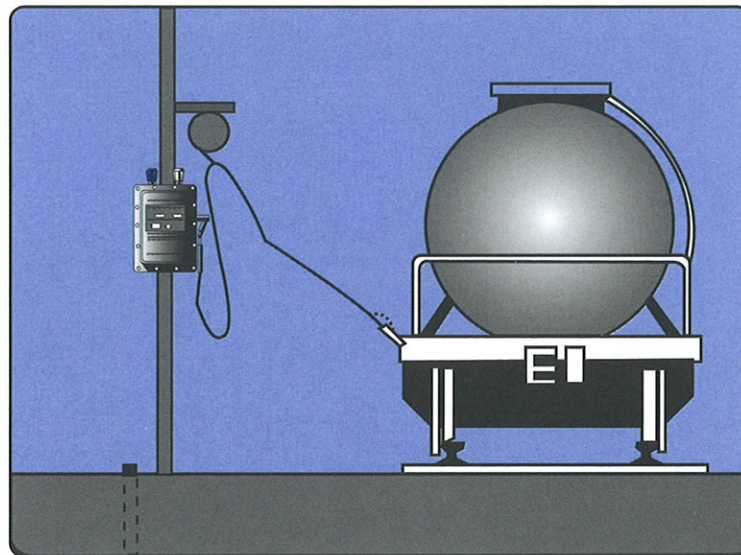

For Railcar Loading

Provides connection to "high-integrity" ground point. Offers visual confirmation of proper ground contact and through "interlocks", can control pumps, valves, motors or interface with PLC or DCS controls. Can also initiate a sound alarm if needed.

NOTE!
BEFORE UNLOADING TANK CAR OR TRUCK,
GROUNDING CLAMPS MUST BE ATTACHED
FOR 5 MINUTES BEFORE INSERTING PIPE.
AFTER LOADING, GROUNDING CLAMPS AND
FILL PIPE SHOULD BE LEFT ATTACHED FOR
5 MINUTES BEFORE REMOVING.

TYPICAL PIPE GROUNDING
JUMPER AT SWIVEL CONNECTIONS

NOTE:
GROUND CONDUCTIVITY OF ALL PIPING,
EQUIPMENT, DEVICES, CABLES AND
CONNECTIONS MUST BE CHECKED FOR
ELECTRICAL CONTINUITY AT THE TIME
OF INSTALLATION AND PERIODICALLY
THEREAFTER.

LARGE TYPICAL
GROUNDING CLAMP

"RETRACT-A-CABLE"
TYPICAL GROUNDING CLAMP
WITH REEL OR RECOILING CABLE

TYPICAL GROUNDING CLAMP

GROUNDING "BUS" (TYPICAL)

GROUND ROD FOR GROUNDING
LOADING RACK/PLATFORM

NOTE!
ANY CONDUCTIVE LEVEL
MEASURING DEVICE OR PIPE
SHALL BE GROUNDED BEFORE
INSERTING INTO ANY CAR OR
TRUCK.

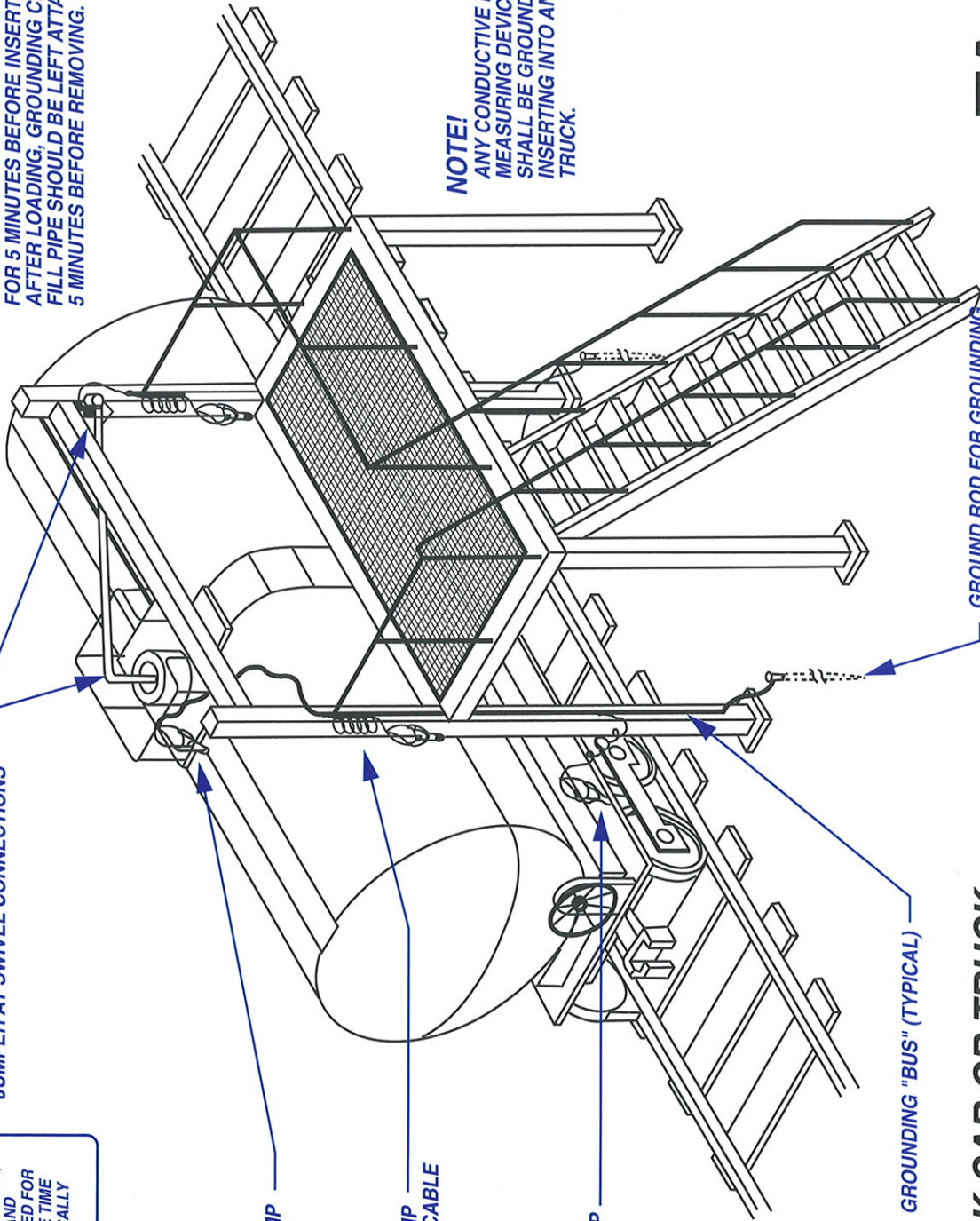

TYPICAL TANK CAR OR TRUCK LOADING/UNLOADING GROUNDING ARRANGEMENT

TA-23

TYPICAL ASSEMBLY NO.23

Grounding Survey Form

Controlling Static Electricity

Static electricity is a major cause of fires and explosions in various industries. The Hazard of an electrostatic spark ignition of flammable vapors can be minimized by taking actions to limit the accumulation of electrostatic charges to safe limits. The purpose of this survey form is to gather enough information to help off-set the potential risks.

Submitted by: _____

Company Name: _____

Address: _____

Telephone: _____ Fax: _____ E-Mail: _____

A. Type of Application: Paint Transfer of Liquids Railcar Truck
 Drums & Containers Piping Systems Aircraft
 Personnel Grounding Other _____.

B. Requirements Temporary Permanent

C. Further description of application and requirements:

D. In reviewing this application booklet, your application is best described in layout TA _____.

E. Is this application Indoors Outdoors

F. Are storage racks used (see layout TA-18)? yes no

G. If transferring liquids, the estimated flow rate is _____ gpm.

H. Describe transfer mechanism _____

I. If railcar application, is it similar to layout TA-23? yes no

J. Are multiple ground connections to one ground bus required? yes no

K. Do you require quick-release harness on clamp (see layout TA-4)? yes no

L. Do you prefer: straight cable retractable reel coiled cable

M. Type of cable preferred: stainless bronze

N. Type of cable diameter and length required: _____

O. Describe atmospheric conditions: dusty wet dry; Relative humidity _____%

Please include any further comments you would like to make and attach a sketch of this area if possible:

Stewart R. Browne Manufacturing Co., Inc.
1165 Hightower Trail
Atlanta, Georgia 30350
(770) 993-9600
FAX (770) 594-7758

SAFETY CHECKLIST

Static Electricity in Flammable Atmospheres

Maximize Safety In The Work Area:

- Verify all operators and managers are trained in safe working practices with flammable products. They need to understand the characteristics and dangers of flammable products and the principles of static control.
- Verify operators are supplied with anti-static dissipative footwear and are provided with natural fiber clothing.
- Verify the product transfer area is suitable for dispensing, transferring, decanting or mixing of flammable products.
- Verify floors are adequately conductive.
- Verify all electrical equipment is appropriate for use in the designated flammable area.
- Verify lift trucks and other vehicles used in the vicinity are fully protected to the appropriate standard.

Minimize Charge Generation:

- Where practical, pipe liquid products directly from storage to the point of use.
- Verify all containers, pipework, hoses, plant, etc., are conductive, bonded together and earthed.
- Minimize product free fall distances.
- Where practical, keep pumping speed to a minimum.

Maintain Safe Working Practices:

- Have a written 'safe system for working' for the handling of flammable products.
- Ensure conductive floors remain non-insulating.
- Ensure all earthing straps, clamps, wires and monitoring systems are regularly inspected and maintained and in good working order.
- Ensure contaminated clothing is changed promptly.
- Ensure all contractors are controlled by strict 'permit-to-work' systems.

Static Grounding Clamps

Stewart R. Browne MFG. Co., inc

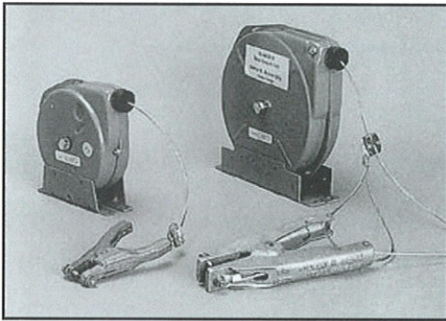

Static Grounding Reels

The use of static cable reels is a long standing method of providing good storage area for cables, away from the corrosive and hazardous elements

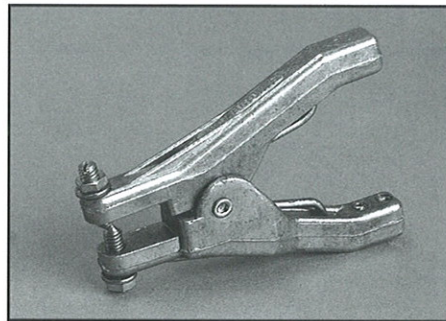

REB Temporary Grounding Clamps FM Approved

Aluminum clamp designed for use on drums, cans, and barrels. Powerful, rugged clamp. 55 lbs. pressure on 1/4" steel plate

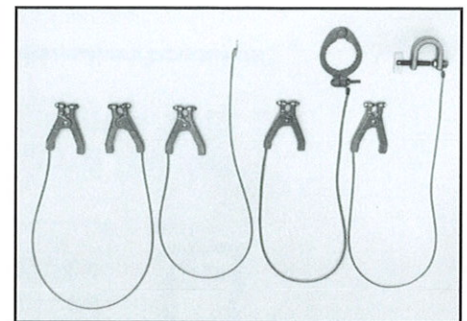

Grounding Assemblies

To satisfy the requirements of almost all grounding and bonding specifications.

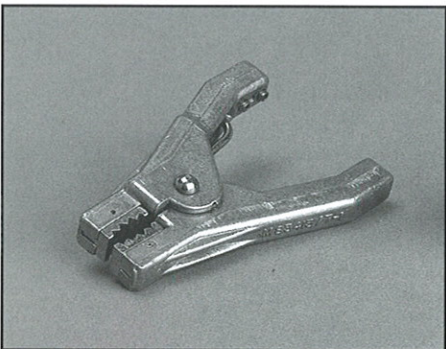

ALS-10A Aircraft Static Bonding and Grounding Clamp

Meets MIL Spec M83413/7-1
Rugged steel jaws ideal to attach to grounding post or landing gear.

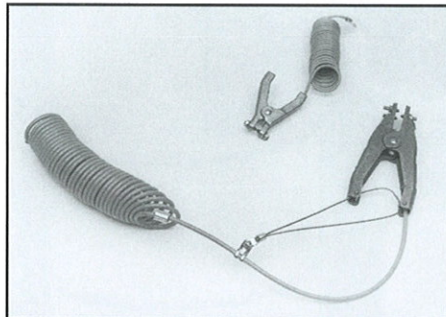

Retractable Grounding Systems

"Retract-a-Clamp" vinyl covered cable recoils itself without any effect of corrosive environments. Ideal for drum loading and vehicle loading.

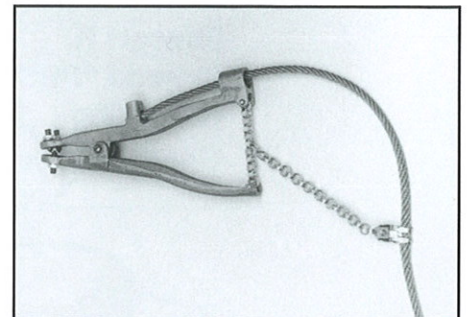

G-40 Series

Bronze ground clamp for tanker trucks and railcars, with automatic chain release. 50 lbs. pressure on 1" plate.

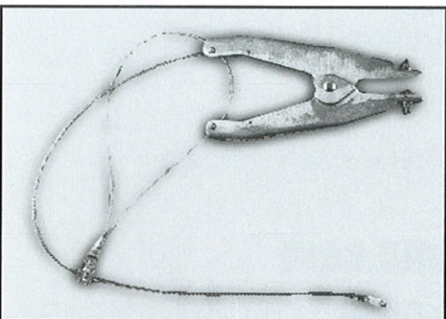

GAT-P Aluminum Grounding Clamp

Designed to ground vehicles when loading flammable liquids. The clamp can be equipped with a release harness. GAT-P-IP for positive ground systems.

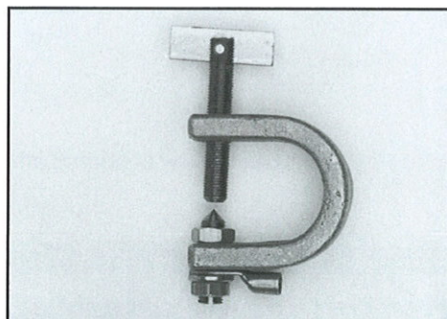

EP-1, EP-2 & EP-3

'C' Clamp used for grounding solvent containers and drums.



JR-150 Series

Pipe clamps designed to completely surround any standard pipe size. Entire clamp is bronze.

Stewart R. Browne Manufacturing Co., Inc.

Made in USA

1165 Hightower Trail • Atlanta, Georgia 30350 • (770) 993-9600 • FAX (770) 594-7758

Stewart R. Browne Products Proudly Made in the U.S.A. FLAMMABLE LIQUID DISPENSING

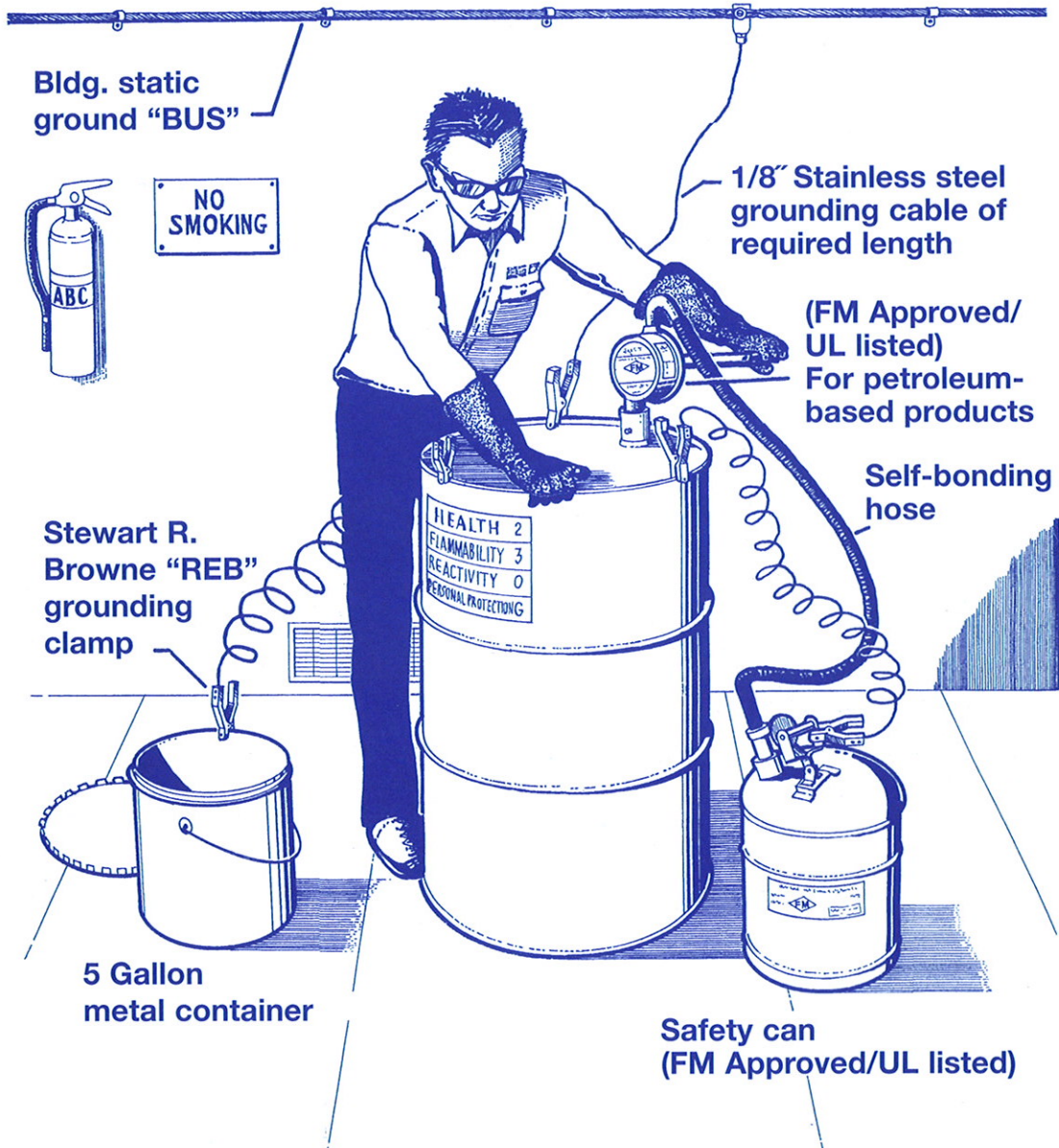

NOTE: FLAMMABLE LIQUID DISPENSING IS TO BE PERFORMED ONLY IN ACCORDANCE WITH ALL FEDERAL, STATE & LOCAL LAWS

**"Visit our website: <http://www.srbrowne.com>
or e-mail stewbrowne@mindspring.com"**