

# DOYLE CAP/CUP CLEANER

DS24-150-4

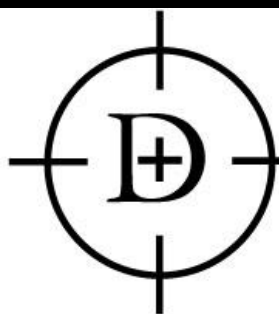

CIRCLE  
DYNAMICS INC.

## **Why do you want a cap cleaner?**

As you know the single most important aspect to running an efficient paint line is cleanliness. This cleanliness extends to paint gun cap or cup as well. Dirty cups cause drips, spits, and KV faults, causing millions in wasted time, paint, parts and man-hours.

All coating applicator manufacturers and painting experts agree that clean dry parts and equipment are fundamental to high first run capability. As paint leaves the applicator the shape air ring becomes contaminated with overspray. Paint defects are the result.

The solution to paint line defects caused by dirty cups and shape rings is a robotic cup cleaner that is:

- Effective
- Easily installed
- Low maintenance

The Doyle robotic cup cleaner will eliminate all problems and paint defects caused by dirty cups and shape rings. Trouble shooting paint line problems and defects requires identifying the cause of the problem. By eliminating all problems related to dirty cups, identifying the root problem becomes much easier, contributing to the success and morale of the paint line team.

## **How the Doyle Cap Cleaner works**

During the cup cleaning the cap cleaner rises and retracts over the dirty cup as follows.

Air is turned on to create a vacuum effect. Air must always be on when the applicator is in the cleaner. (See Cleaning Sequence)

Solvent is turned on and the applicator descends at approx. 50mm per second to a point where the bottom of the shape air ring is 90mm below the top of the lid.

Solvent is turned off and the applicator ascends at approx. 50mm per second with the air still on, until it is in the home position.

The air is now turned off and the cup is clean.

Programming instructions give ideal starting positions and speeds. Changes to the programming may be necessary to suit each plants application and solvent consumption.

# Installing the DS24-150-4 Cap Cleaner

The DS24-150-4 has a footprint of 12" x 12" (305mm x 305mm) and must be installed over grating, in the correct location for the docking station.

Install a 3/8" or other suitable non-regulated heated solvent supply.

Heated solvent supply valve should be located as close as possible to the lid of the cleaner. See Figure 3

The cap cleaner contains a check valve in the spray block and will not allow siphoning of the solvent.

Connect the solvent supply line to the stainless steel flow restrictor (part #59004) on the lid.

Install a 3-way regulated air valve that has a minimum CV rating of 1.7 supplied with plant air pressure. See Figure 3

Connect a 3/8" air supply line from the 3-way air valve to the brass connector (part #60122) on the lid.

## Flow Restrictor (part #59004)

The flow restrictor is supplied to eliminate the need for solvent regulation and has a built-in 40 micron stainless steel filter.

At 100 psi supply:

- #60 restrictor will allow 20cc/sec.
- #55 restrictor will allow 30 cc/sec.
- #50 restrictor will allow 40cc/sec.

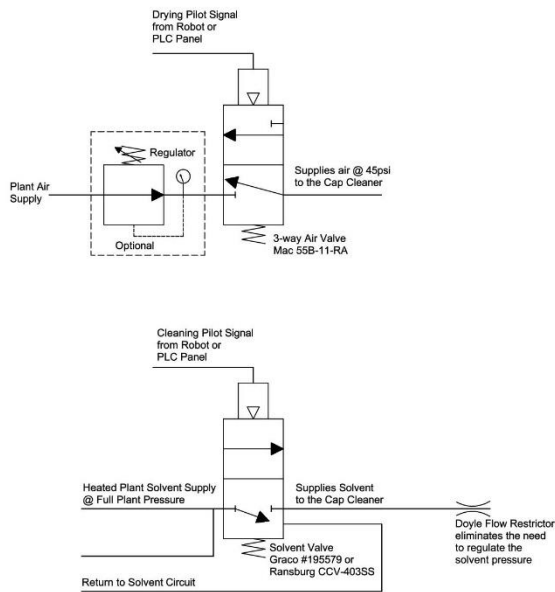

FIGURE 3

## Operating the Doyle DS24-150-4 Cap Cleaner

Initiate the clean cycle.

Insert the applicator into the home position.

Turn the vacuum air on.

Turn the solvent on.

Lower the applicator @ 50mm/sec. to the optimum cleaning position, where the bottom of the shape air ring is 90mm below the top of the cleaner lid. This position may vary depending on your individual needs, and will be controlled by adjusting your stop.

Complete the purge and recharge of the applicator.

Turn the solvent off.

Raise the applicator @ 50mm/sec. until home.

Turn drying air off.

Applicator may now leave the home position.

## Maintenance

Maintenance on the DS24-150-4 requires replacing the balls, springs, o-rings, and nozzles in the spray heads once per year. Use kit #500-030. See Figure 2

(Use kit #500-030W for Waterborne)

### Disassemble head:

- Remove 2 screws (25)
- Remove retainer plate (11)
- Remove nozzle, spring, check ball, o-ring (21, 22, 23, 24)

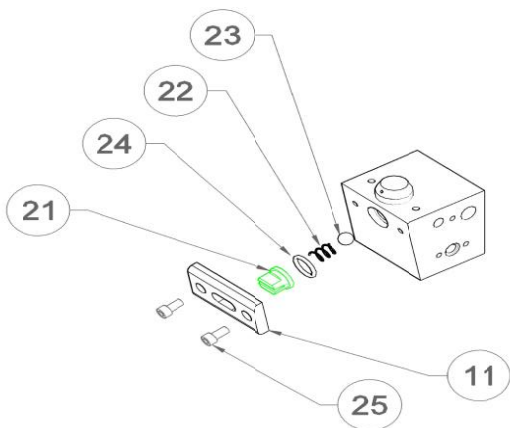

### Reassemble head:

- Replace nozzle spring, check ball, o-ring with kit # 500-030 (21, 22, 23, 24)
- Reinstall original retainer plates (11) with original screws. (25)

**\*DO NOT reuse Teflon O-ring**

FIGURE2

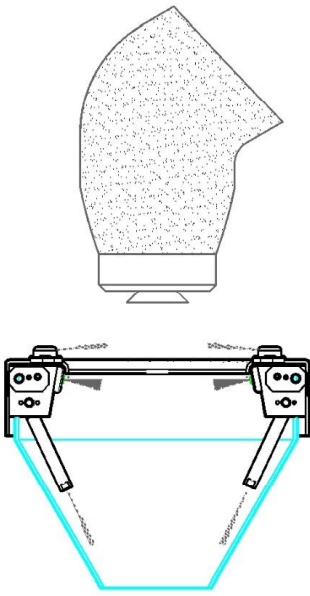

**APPLICATOR IN HOME POSITION.  
AIR ON.  
SOLVENT ON.**

**1**

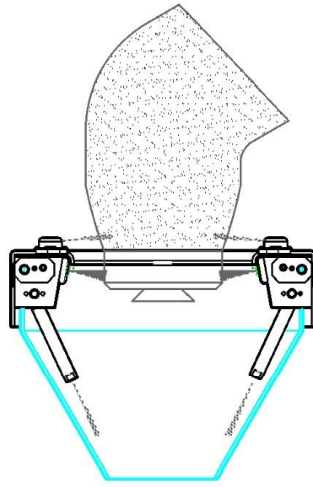

**LOWER APPLICATOR AT A RATE OF 50mm  
PER SECOND TO A DEPTH OF 50mm BELOW  
TOP OF CLEANER.  
PURGE.**

**2**

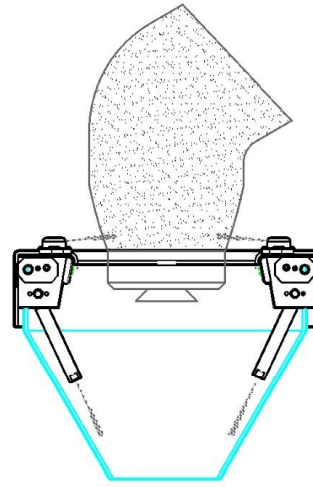

**LEAVE AIR ON.  
TURN SOLVENT OFF.**

**3**

**CLEANING SEQUENCE  
DS24-150-4**

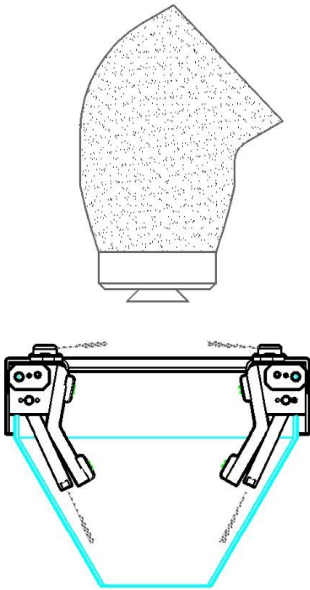

**RETRACT APPLICATOR AT A RATE OF 50mm  
PER SECOND TO HOME POSITION.**

**4**

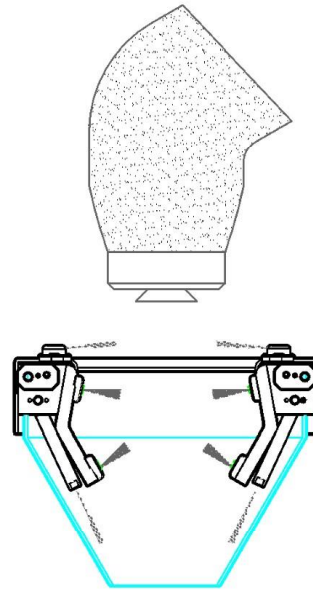

**TURN AIR OFF.**

**5**

## PARTS LIST 1 OF 3

### MODEL DS24-150-4

1	59008	LATCH COVER
2	500-025	CATCH
3	500-027	RIVET
4	500-011	BRASS AIR FITTING
5	500-016	STAINLESS FLOW RESTRICTOR
6	500-026	FLAT HEAD SCREW
7	59011	SPRAY BLOCK - 180 LARGE
8	500-001	SPRAY BLOCK - SMALL
9	500-009	STRIKE
10	500-017	DRIVE EXTENSION
11	500-006	RETAINER PLATE
12	500-031	RIGHT HAND KEEPER PLATE
13	500-032	LEFT HAND KEEPER PLATE
14	500-048	O-RING
15	500-015	LONG SOLVENT TUBE 90
16	500-047	O-RING
17	500-013	LONG AIR TUBE 90
18	500-014	SHORT SOLVENT TUBE 90
19	500-012	SHORT AIR TUBE 90
20	60128	HEX SOCKET PLUG
21	500-005	SOLVENT NOZZLE
22	500-003	CHECK SPRING
23	500-002	CHECK BALL
24	500-004	O-RING
25	500-007	CAP SCREW
26	500-019	LINER
27	500-024	STAND WITH COVER
28	500-020	FUNNEL
29	500-052	GROUND LUG
30	500-051	STATIC MIXER INSERT
31	59009	DUMP LINE
32	500-028	BUTTON HEAD BOLT, WASHER & NUT
33	500-010	LID
34	500-021	BOLT
35	500-023	WASHER
36	500-022	NUT

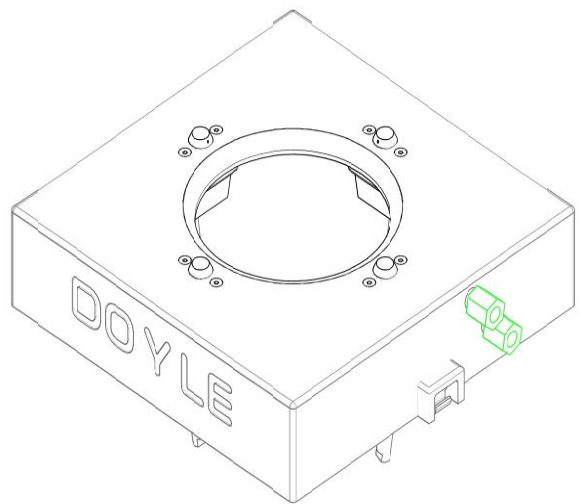

PARTS LIST 2 OF 3

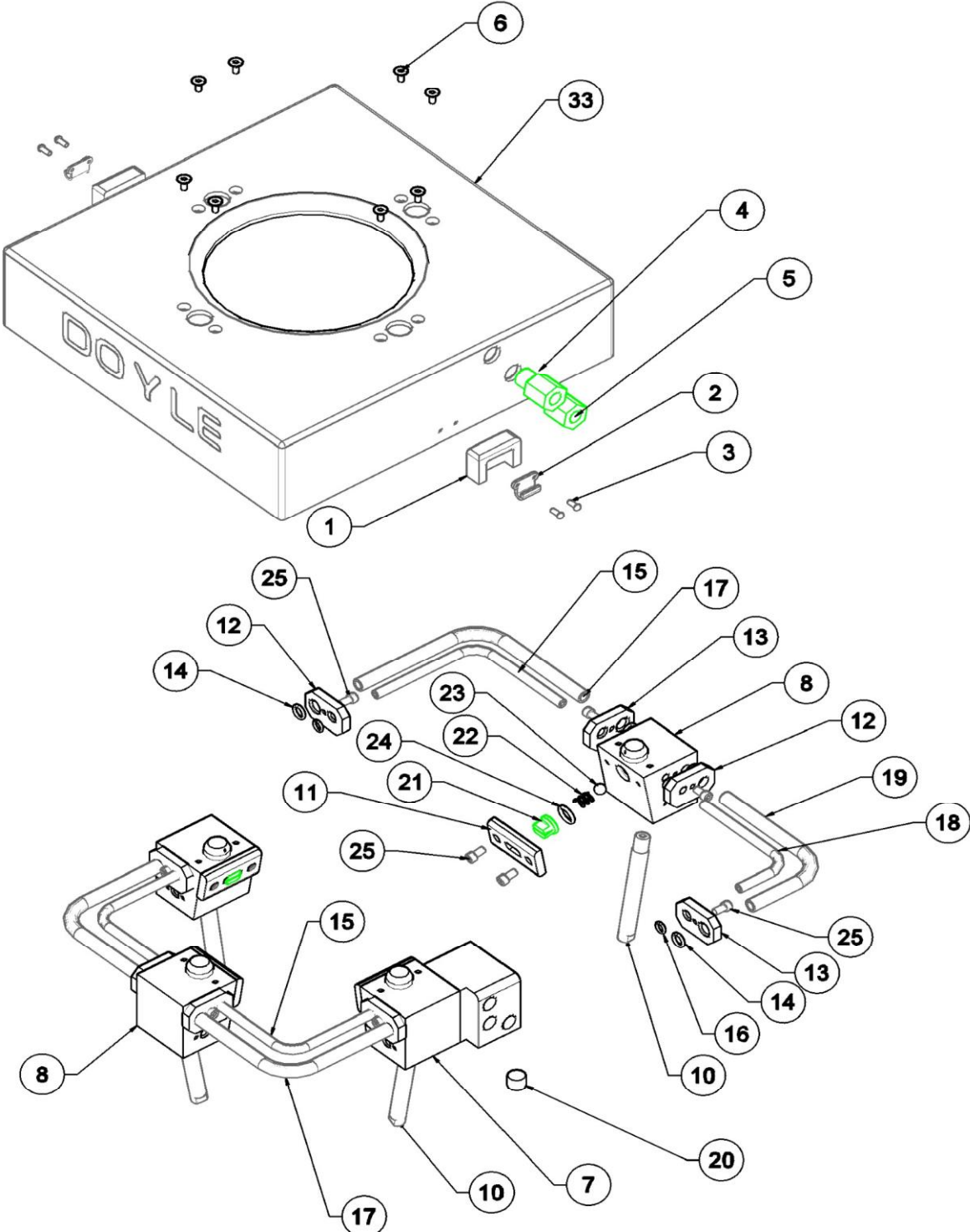

# PARTS LIST 3 OF 3

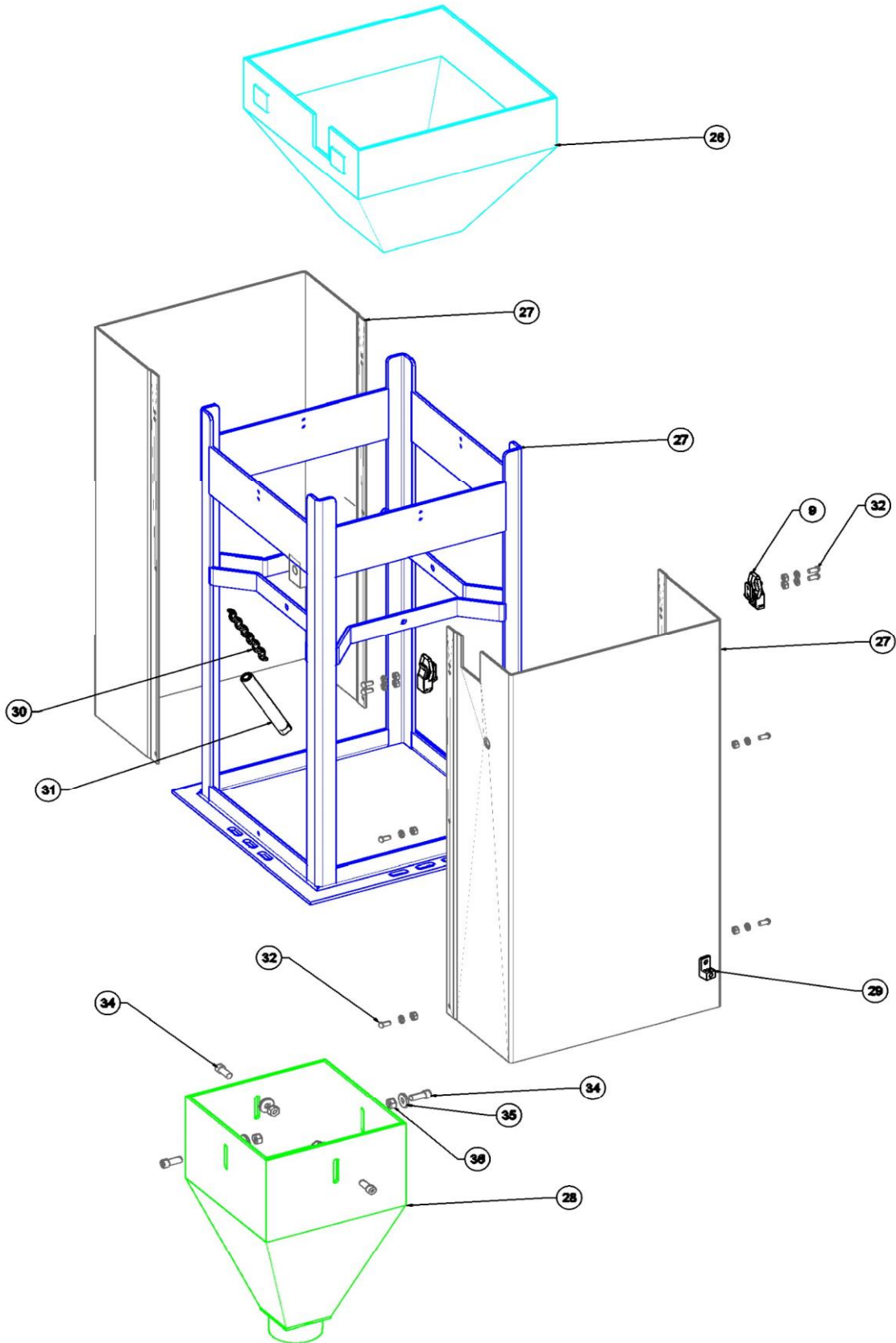



## One Year Limited Warranty

### **PRODUCT LIMITED WARRANTY:**

Manufacturer Circle Dynamics Inc. warrants its product to be free from defects in workmanship and/or material for one (1) year from date of shipment from factory. Manufacturer shall have no liability under the warranty or otherwise if:

1. The product is not inspected by the buyer within ten (10) days after delivery.
2. The product is used other than in accordance with current operating instructions.
3. The product is subject to any abuse or abnormal or unintended use.
4. A claim in writing under this warranty is not presented to the manufacturer at Peterborough, Ontario, Canada, address on or before ninety (90) days after the date of alleged defect was first known or could reasonably have been known, whichever is sooner.
5. The product is not returned unaltered to Manufacturer within such ninety (90) day period for inspection.

Any warranty extends only to the first user of the product.

### **DISCLAIMER:**

The above Limited Warranty is EXCLUSIVE of any and all other warranties, liabilities, or obligations of manufacture. MANUFACTURER DISCLAIMS ANY OTHER WARRANTY AND MAKES NO REPRESENTATIONS OR WARRANTY OF ANY KIND EXPRESS OR IMPLIED, INCLUDING BUT NOT LIMITED TO ANY IMPLIED WARRANTY OF MERCHANTABILITY OR FITNESS FOR A PARTICULAR PURPOSE OR OTHER MATTER. Manufacturer neither authorizes nor assumes responsibility for any affirmation of fact, description or other representation with respect to its product.

### **LIMITATIONS OF LIABILITY:**

Manufacturer's liability shall be limited to:

1. Product replacement.
2. Product repair or
3. A refund of the product purchase price F.O.B. point of manufacture, and as Manufacturer, at its opinion may elect.

The above remedies shall be Buyer's exclusive remedies for any and all loss or damaged claimed by or through Buyer from any cause whatsoever including, without limitation, inability to supply product, errors or delays in shipment. Manufacturer shall not be liable for any incidental, special, or consequential damages.

**CE: When plastic hoses are used, the plastic hoses must be according to EN13463-1 (anti-static). There is no self-ignition source in the DS12-180-8 Applicator Cleaner.**

**Attach bonded cable to all ground lugs.**

**Shut down all high voltage to applicator prior to entering the cleaner.**