

**BINKS®**

# BINKS DX70 Diaphragm Pumps



**High Performance  
Pump Packages**

*With Built In Fluid Regulator*



# The Binks DX70 is the perfect solution for one gun spray applications with faster color changes and quick refills for less production downtime.

## Binks DX70 Air Operated 1:1 Ratio Diaphragm Pump

- The pump features a unique diaphragm no-crease shape for a long life. The DX-70 also includes a built in fluid regulator which ensures a constant and virtually pulse free fluid delivery for direct feed to spray guns. This design reduces the cost and complexity of additional fluid regulators or surge chambers.

The "built in" fluid regulator provides easily adjustable surge free paint flow. This feature costs extra on competitive models.



- Air Valve provides smooth, quiet and surge free paint delivery up to 34 fl. Oz/min (1000 cc/min)
- Acetal Pump Body with Stainless Steel balls and soft seats allow for universal paint compatibility for solvents and water based materials
- The DX-70 is 1:1 diaphragm pump designed for supply of paints and materials to spray gun and fluid transfer applications.



DX70R3-CFG Cart mounted pump with 1.4 gal (6L) gravity bucket feed, filter and three air controls.



DX70R3-WF Wall mounted pump with paint filter and three air controls (Pail not included).



DX70R3-TF Tripod mounted pump outfit with three air controls.



DX70R3-PFA Pail mounted pump with agitator, filter and three air controls (Pail not included).



WOODWORKING



AEROSPACE

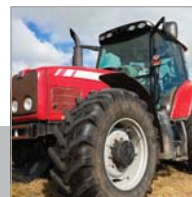

AGRICULTURAL AND OFF ROAD

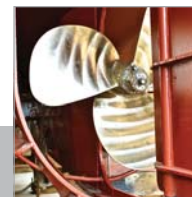

MARINE INDUSTRY



TRUCK AND BUS

### COATING TYPES AND APPLICATIONS

- Solvent Based Materials
- Water Based Materials
- Stains, Lacquers, Varnishes
- Sealers and Undercoats
- Plus Many others



# Pump Packages

## Pump Package (no gun) part numbers

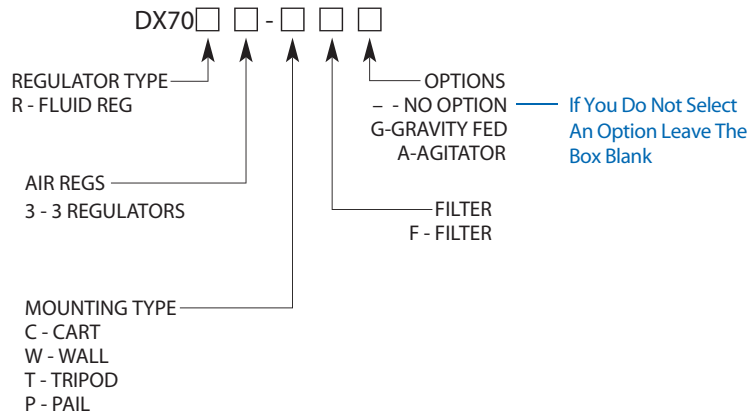

## DESIGN YOUR DX70 PUMP PACKAGE

DX70 PUMP PACKAGE CONTENTS AND PART NUMBERS	DX70R3-PF	DX70R3-PFA	DX70R3-CF	DX70R3-CFG	DX70R3-WF	DX70R3-TF	DX70R3-TFG
DX-70 Bare Pump	•	•	•	•	•	•	•
Fluid Regulator	•	•	•	•	•	•	•
Filter Assembly	•	•	•	•	•	•	•
Air Controls 3 Regulators	•	•	•	•	•	•	•
Siphon Hose	•	•	•	•	•	•	•
Agitator		•					
Gravity Feed 1.4 gal (6L) hopper				•			•
Pail Mount	•	•					
Tripod Mount						•	•
Cart Mount			•	•			
Wall Mount					•		

## SPARE PARTS

PART NUMBER	DESCRIPTION
DXK-2	Check Valve Kit
DXK-3	Diaphragm Kit
DXK-4	Shaft and Seal Kit
DXK-15	Fluid Regulator Kit
DXA-AC3	Air Control (3 regs)
DXA-F10ME100	Filter Assembly 100 mesh
VS-58	Filter 100 mesh
VS-58-60	Filter 60 mesh
DXA-DVT	Dump valve kit
DXA-DVW	tripod/pail
41-3312-S	Dump valve kit wall/cart

## BARE PUMPS

PART NUMBER	FITTINGS	FLUID REGULATOR
DX70R-MM	Male inlet/ Male outlet	Yes
DX70N-FF	Female inlet/ Female outlet	No

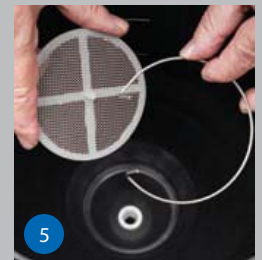
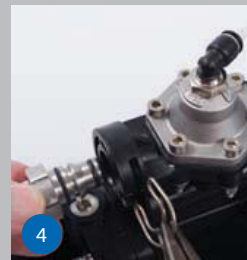

1. Stainless Steel fluid filter with mesh sizes 60 and 100\* (\*100 mesh supplied as standard).
2. CE & ATEX approved with Earthing/grounding cable as standard.
3. All suction pick up tubes include stainless steel strainers.
4. Unique quick release air, fluid inlet and outlet connections for easy, faster servicing.
5. Gravity feed outfits include strainer inside the hopper.



## PUMP SPECIFICATIONS

DX70 PUMP SPECIFICATION (BARE PUMP)	DESCRIPTION
Pump Ratio	1 to 1
Max Air Pressure	100 psi/7 bar
Nominal Flow Volume/Cycle	0.018 gal (0.07 L)
Fluid Output@60 Cycles/min	1.1 gal/min (4.2 l/min)
Max Recommended Continuous Cycle Rate	10 cycles/min
Max Recommended Intermittent Cycle Rate	30 cycles/min
Inlet Fluid Connection	3/8" Universal (BSPP/NPSM) Male or Female
Outlet Fluid Connection	3/8" Universal (BSPP/NPSM) Male or Female
Maximum Dry/Wet Lift	21.8 feet (6.6 m)
Air Inlet	1/4" (BSPP) Female
Air Volume /cycle@ 100 psi	0.027 SCFM
Air Volume 10 cycles/min 100 psi/6.9 cycles	0.27 SCFM/min
Air Volume 30 cycles/min 100 psi/6.9 cycles	0.82 SCFM/min
Noise Level	68 dB
Weight	4.9 lbs (2.2 kg)



## DX70 READY ASSEMBLED SPRAY OUTFITS INCLUDE SPRAY GUN

OUTFIT NUMBER	PUMP PART NUMBER	MOUNT	TROPHY GUN PART NUMBER
98-3221	DX70R3-PF	Pail	2465-HV1
98-3224	DX70R3-PFA	Pail w/ agitator	2465-HV1
98-3226	DX70R3-CF	Cart	2465-HV1
98-3227	DX70R3-TF	Tripod	2465-HV1
98-3228	DX70R3-WF	Wall	2465-HV1

Outfits include Trophy HVLP Spray Gun with 1.2 mm, 1.4 mm, and 1.8 mm set ups, 25' Ergoflex Hose, and 25' Fluid Hose

98-3224 pail mount with agitator spray package (pail not included)

## BINKS DX SERIES PUMP 5-YEAR WARRANTY

Binks® warrants to the original end-use purchaser that the Binks branded products "DX" shall not fail under normal use and service due to a defect in material or workmanship within five (5) years from the date of shipment from Binks.

Binks DX Series Pump 5-Year Warranty does not include normal wear.

For further technical information please refer to the Binks DX70 Diaphragm Pumps Service Bulletin.

## Sales and Service through our Global Network of Distributors

Finishing Brands Offices

Americas: USA ▪ Mexico ▪ Brazil  
 Europe/Asia/Africa: United Kingdom ▪ France ▪ Germany ▪ India  
 Pacific Rim: China ▪ Japan ▪ Australia

**BINKS®**

www.binks.com  
 1.800.99.BINKS

www.finishingbrands.com

**Finishing Brands**

A CARLISLE COMPANY

