

### Main Features

- **High Quality materials and surface treatments** are used in the construction of these pumps to ensure extended operational life, including Stainless steel fluid sections, ideal for waterborne, solvent based and other paints.
- **Horizontal Short Stroke Design** - Equal thrust on both pistons provide identical flow and pressure for both strokes. Permits a higher cycle rate than conventional vertical Pumps and thus more flexibility for paint flow range.
- **Fluid Seal** – Piston seal is lubricated by paint on both sides, increasing seal life. Design means No external paint leaks when seal needs replacement.
- **Bellows seal** - No exposed shaft seal packing eliminating the need for maintenance and lubrication of the shaft packing. Vital to the user when pumping Light (UV) and Moisture sensitive (Catalyst) materials.
- **Fluid Sections** - Tungsten carbide ball seats & ceramic coated pistons, ensure maximum operating life between servicing providing capability for pumping aggressive and abrasive materials.
- **Low Ice Air Motor** - No Lubricator required. Control Valve uses quick exhaust technology (Patented design) to remove risk of valve icing and stalling.
- **Control Valve** - Robust Metal spool and sleeve valves for long service life, incorporating magnetic detent to eliminate stall condition (Patented design).
- **Stroke Counter Port** - Option to monitor Pump life cycle data.
- **Fluid Connections** - Inlet and outlet connections, guarantee a smooth internal pipe connection without paint entrapment pockets.

### Description

The Maple Pump is a horizontal piston pump for pumping Solvent / Waterborne Paints, Solvents and other suitable materials.

The unit combines an energy efficient air motor with low shear fluid section technology.

The Maple Pump achieves a reciprocating drive by using high technology ground steel spool and sleeve air valves to control the air motor reversal, providing reciprocating motion.

The patented air valve design ensures a positive magnetic detent for the main and pilot air valves thus removing the possibility for a stall condition. The air motor also utilises the patented Binks Low Ice quick exhaust technology to prevent air valve freezing conditions when high cycle speeds are employed.

Equal thrust on each stroke due to the horizontal configuration incorporating the dual piston rod design gives a balanced fluid pressure output and reduces fluid pressure fluctuations to a minimum.

The air pump is furnished with twin exhaust mufflers to control exhaust noise emission. An adapter kit is available to facilitate connection to a remote exhaust system if required.

## Specifications

Description	Unit
Part No.	104042
Recommended max. Continuous cycle rate	20 cycles/min (4LPM)
Intermittent cycle rate	40 cycles/min (8LPM)
Fluid Volume / cycle	0.053 US Gal / 0.2 L
Equivalent Flow at 60 cycles/min	3.2 US Gal / 12 L
Ratio	25 : 1
Air Inlet Pressure	15 – 90 psi / 1 – 6.2 Bar
Air inlet size	1/2" BSP / NPS
Inlet Fitting	1" Sanitary
Outlet Fitting	1/2" NPT(f)
Weight	40 Kg

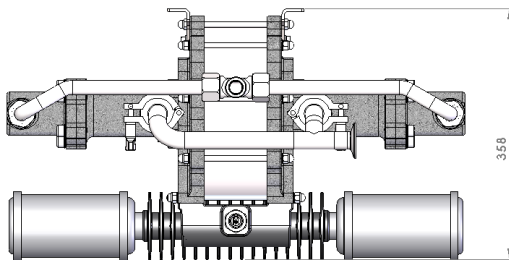
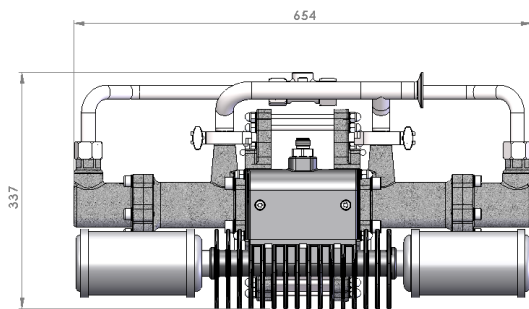

## Accessories

Part. No.	Description
192009	1 1/2" Sanitary Clamp
192206	1" Sanitary Gasket
193275	1" Sanitary - 3/4" NPTF Adaptor