

RansFlex RFXA Electrostatic Automatic Spray Gun

ELECTROSTATICS



The RansFlex RFXA & RFXAW automatic electrostatic spray gun, provide best in class atomisation for automatic applications. For application versatility, the spray gun is available in water or solvent and bleed or non-bleed versions.

The RansFlex Automatic spray gun is an air atomising, low-pressure electrostatic spray gun powered by a compact power supply. The spray gun offers superior atomisation and a quality finish time after time. The air cap and retaining ring encapsulation keeps parts from falling into booth grates, minimising replacement costs. The indexing air cap also helps position the cap for

quick and easy alignment. The RansFlex automatic spray gun, designed with robust internal components, such as high-wear nozzles, provides years of service, reliability and dependability.

The spray gun's internal cascade generates high voltage to the electrode creating an electrostatic field between the atomiser and the target, providing a repeatable application and the highest transfer efficiency. For optimum safety, the spray gun and power supply are approved to meet stringent ATEX EN 50 050 and FM (US & Canada) standards.

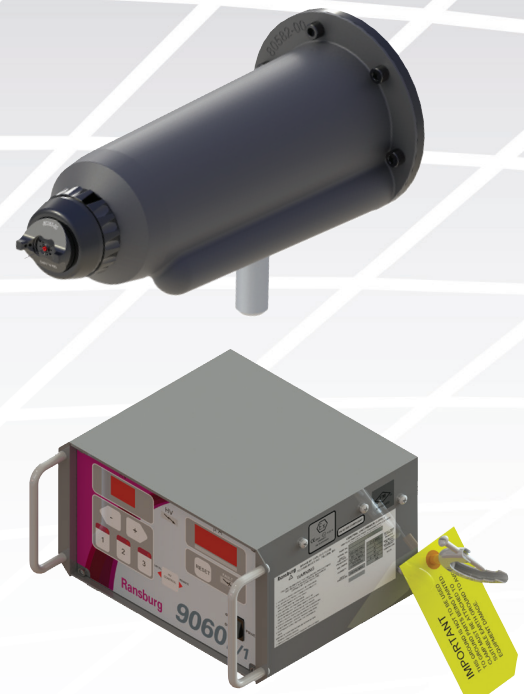

Best in Class Atomisation

Built on proven DeVilbiss atomisation technology.

Superior atomisation technology and versatility

Two atomisation technologies, conventional and Trans-Tech® with nozzles available in 0.7mm, 1.0mm, 1.2mm, 1.4mm, 1.8mm and round.

Proven reliability

Five-year limited warranty against manufacturer's defects.

Optimal adjustment

Independent atomisation and fan air.

Meets stringent FM/ATEX

Complies with all globally recognised standards and promotes confidence in a quality product.

MARKETS AND APPLICATIONS

- General Industrial
- Job Shops
- Automotive Parts

RansFlex Solvent – Model 80665

RansFlex model 80665 is designed for use solvent materials only.

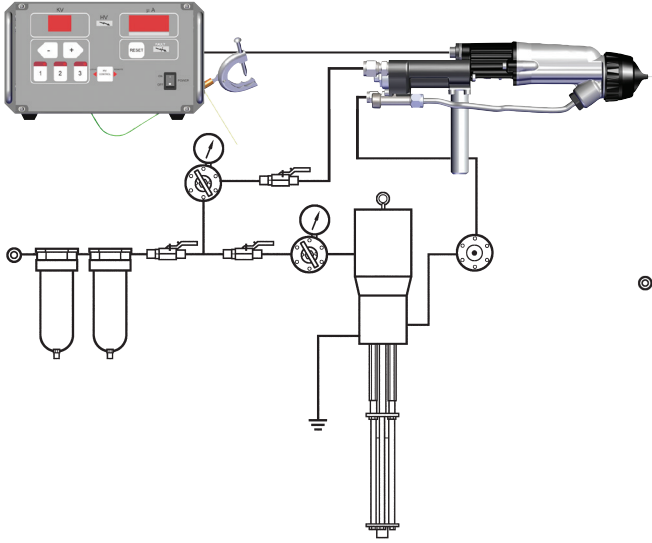

RansFlex Direct Charge Water - Model 80765

RansFlex model 80765 is designed for direct charge waterbase applications only. The waterborne fluid supply system **MUST** be isolated from ground to allow proper electrostatic charging of the fluid. All waterbase materials used **MUST** be classified as non-flammable. The mixture, with air, cannot be ignited and an energy source less than 500 mJ.

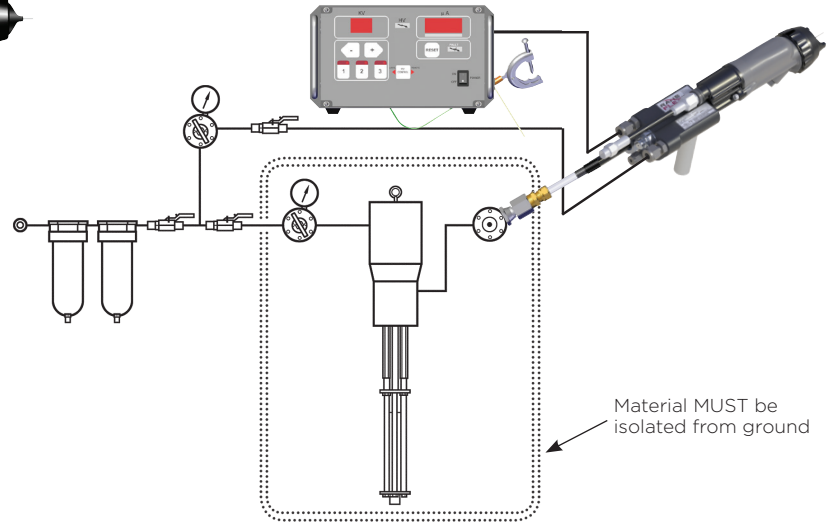

Typical System Installation

SPECIFICATIONS

RansFlex (Models 80665 & 80765)

Environmental/Physical

Length:	273 mm (10.75 inches)
Weight (without hose):	1050 grams (37 oz.)

Electrical

Operating Voltage:	65kV DC (-) max.
Current Output:	90 μ A max.

Paint Resistance:	
Solvent (model 80665):	.1 M Ω to infinity
Water (model 80765):	Waterbase material only

Mechanical

Fluid Flow Capacity	1,000 mL/min*
Wetted Parts:	Stainless, polyethylene, nylon, acetal polymer
Low Voltage Cable:	10m, 15m, 20m, 30m
Fluid Hose (80303/80501):	10m, 15m, 20m, 30m
Operating Pressure (Air Spray)	
Fluid:	0-6.9 bar (0-100 psi)
Air:	0-6.9 bar (0-100 psi)
Trigger:	5.5-6.9 bar (80-100 psi)
Ambient Temperature:	5°C to 40°C (41°F to 104°F)

*Reflects the maximum fluid volume the spray gun can deliver. The maximum spray volume effectively atomised depends on fluid rheology, spray technology and finish quality required.

For further technical information refer to the RansFlex automatic spray guns Service Bulletins.